

OneWireless
XYR 6000 Temperature and
Discrete Input Transmitter
R120 User's Manual

34-XY-25-16
Revision 8
November 2010

Notices and Trademarks

**Copyright 2007-10 by Honeywell International Inc.
Revision 8 November 2010**

While this information is presented in good faith and believed to be accurate, Honeywell disclaims the implied warranties of merchantability and fitness for a particular purpose and makes no express warranties except as may be stated in its written agreement with and for its customers.

In no event is Honeywell liable to anyone for any indirect, special or consequential damages. The information and specifications in this document are subject to change without notice.

Honeywell, PlantScape, Experion PKS, and **TotalPlant** are registered trademarks of Honeywell International Inc.

Other brand or product names are trademarks of their respective owners.

Honeywell Process Solutions

1860 West Rose Garden Lane
Phoenix, Arizona 85027

About This Document

This document describes preparation, operation and maintenance of the XYR 6000 Wireless Temperature/DI Transmitters. Mounting, installation and wiring are covered in other documents.

Honeywell does not recommend using devices for critical control where there is a single point of failure or where single points of failure result in unsafe conditions. OneWireless is targeted at open loop control, supervisory control, and controls that do not have environmental or safety consequences. As with any process control solution, the end-user must weigh the risks and benefits to determine if the products used are the right match for the application based on security, safety, and performance. Additionally, it is up to the end-user to ensure that the control strategy sheds to a safe operating condition if any crucial segment of the control solution fails.

Revision Information

Document Name	Document ID	Revision Number	Publication Date
XYR 6000 Temperature and Temperature/Discrete Input Transmitter R120 User's Manual			
ISA Battery Pack added	34-XY-25-16	8	November 2010

References

The following list identifies all documents that may be sources of reference for material discussed in this publication.

Document Title

XYR 6000 Transmitters Quick Start Guide
Getting Started with Honeywell OneWireless Solutions
OneWireless Wireless Builder User's Guide
OneWireless Builder Parameter Reference

Support and contact info

United States and Canada

Contact: Honeywell Process Solution

- Global Technical Support - Phone: 001-800-423-9883
- Customer Service (HFS) - Phone: 001-800-343-0228
- Outside United States - Phone: 001-215-641-3610

Calls are answered by dispatcher between 6:00 am and 4:00 pm Mountain Standard Time. Emergency calls outside normal working hours are received by an answering service and returned within one hour.

Email support: ask-ssc@honeywell.com

Mail: Honeywell Process Solutions
1860 West Rose Garden Lane,
Phoenix, Arizona 85027

Europe

Contact: Honeywell TAC-EMEA
Phone: +32-2-728-2732
Facsimile: +32-2-728-2696
Mail: TAC-BE02
Hermes Plaza
Hermeslaan, 1H
B-1831 Diegem, Belgium

Pacific

Contact: Honeywell Global TAC – Pacific
Phone: 1300-300-4822 (toll free within Australia)
+61-8-9362-9559 (outside Australia)
Facsimile: +61-8-9362-9564
Mail: Honeywell Limited Australia
5 Kitchener Way
Burswood 6100, Western Australia
Email: GTAC@honeywell.com

India

Contact: Honeywell Global TAC – India
Phone: +91-20- 6603-9400
Facsimile: +91-20- 6603-9800
Mail: Honeywell Automation India Ltd.
56 and 57, Hadapsar Industrial Estate
Hadapsar, Pune –411 013, India
Email: Global-TAC-India@honeywell.com

Korea

Contact: Honeywell Global TAC – Korea
Phone: +82-2-799-6317
+82-11-9227-6324
Facsimile: +82-2-792-9015
Mail: Honeywell Co., Ltd
17F, Kikje Center B/D,
191, Hangangro-2Ga
Yongsan-gu, Seoul, 140-702, Korea
Email: Global-TAC-Korea@honeywell.com

People's Republic of China

Contact: Honeywell Global TAC – China
Phone: +86- 21-5257-4568
Mail: Honeywell (China) Co., Ltd
33/F, Tower A, City Center, 100 Zunyi Rd.
Shanghai 200051, People's Republic of China
Email: Global-TAC-China@honeywell.com

Singapore

Contact: Honeywell Global TAC – South East Asia
Phone: +65-6580-3500
Facsimile: +65-6580-3501
+65-6445-3033
Mail: Honeywell Private Limited
Honeywell Building
17, Changi Business Park Central 1
Singapore 486073
Email: GTAC-SEA@honeywell.com

Taiwan

Contact: Honeywell Global TAC – Taiwan
Phone: +886- 7- 536-2567
Facsimile: +886-7-536-2039
Mail: Honeywell Taiwan Ltd.
17F-1, No. 260, Jhongshan 2nd Road.
Cianjhen District
Kaohsiung, Taiwan, ROC
Email: Global-TAC-Taiwan@honeywell.com

Japan

Contact: Honeywell Global TAC – Japan
Phone: +81-3-6730-7160
Facsimile: +81-3-6730-7228
Mail: Honeywell Japan Inc.
New Pier Takeshiba, South Tower Building,
20th Floor, 1-16-1 Kaigan, Minato-ku,
Tokyo 105-0022, Japan
Email: Global-TAC-JapanJA25@honeywell.com

World Wide Web

Honeywell Solution Support Online:

<http://www.honeywell.com/ps/hfs>

Elsewhere

Call your nearest Honeywell office.











Training Classes

Honeywell Automation College:





<http://www.automationcollege.com>

Symbol Definitions

The following table lists those symbols used in this document to denote certain conditions.

Symbol	Definition
	ATTENTION: Identifies information that requires special consideration.
	TIP: Identifies advice or hints for the user, often in terms of performing a task.
CAUTION	Indicates a situation which, if not avoided, may result in equipment or work (data) on the system being damaged or lost, or may result in the inability to properly operate the process.
	CAUTION: Indicates a potentially hazardous situation which, if not avoided, may result in minor or moderate injury. It may also be used to alert against unsafe practices. CAUTION symbol on the equipment refers the user to the product manual for additional information. The symbol appears next to required information in the manual.
	WARNING: Indicates a potentially hazardous situation, which, if not avoided, could result in serious injury or death. WARNING symbol on the equipment refers the user to the product manual for additional information. The symbol appears next to required information in the manual.
	WARNING, Risk of electrical shock: Potential shock hazard where HAZARDOUS LIVE voltages greater than 30 Vrms, 42.4 Vpeak, or 60 VDC may be accessible.
	ESD HAZARD: Danger of an electro-static discharge to which equipment may be sensitive. Observe precautions for handling electrostatic sensitive devices.
	Protective Earth (PE) terminal: Provided for connection of the protective earth (green or green/yellow) supply system conductor.
	Functional earth terminal: Used for non-safety purposes such as noise immunity improvement. NOTE: This connection shall be bonded to Protective Earth at the source of supply in accordance with national local electrical code requirements.
	Earth Ground: Functional earth connection. NOTE: This connection shall be bonded to Protective Earth at the source of supply in accordance with national and local electrical code requirements.
	Chassis Ground: Identifies a connection to the chassis or frame of the equipment shall be bonded to Protective Earth at the source of supply in accordance with national and local electrical code requirements.

continued

Symbol	Description
	<p>The Factory Mutual[®] Approval mark means the equipment has been rigorously tested and certified to be reliable.</p>
	<p>The Canadian Standards mark means the equipment has been tested and meets applicable standards for safety and/or performance.</p>
	<p>The Ex mark means the equipment complies with the requirements of the European standards that are harmonised with the 94/9/EC Directive (ATEX Directive, named after the French "ATmosphere EXplosible").</p>
	<p>For radio equipment used in the European Union in accordance with the R&TTE Directive the CE Mark and the notified body (NB) identification number is used when the NB is involved in the conformity assessment procedure. The alert sign must be used when a restriction on use (output power limit by a country at certain frequencies) applies to the equipment and must follow the CE marking.</p>
	<p>The C-Tick mark is a certification trade mark registered to ACMA (Australian Communications and Media Authority) in Australia under the Trade Marks Act 1995 and to RSM in New Zealand under section 47 of the NZ Trade Marks Act. The mark is only to be used in accordance with conditions laid down by ACMA and RSM. This mark is equal to the CE Mark used in the European Union.</p> <p>N314 directly under the logo is Honeywell's unique supplier identification number.</p>

Contents

Support and contact info.....	iv
1. INTRODUCTION	1
1.1 Purpose.....	1
1.2 Scope.....	1
1.3 OneWireless network overview	1
1.4 About the transmitter.....	1
Inputs.....	1
2. SPECIFICATIONS	4
2.1 European Union Usage.....	4
2.2 Certifications and approvals.....	5
Transmitter	5
Authentication Device.....	6
2.3 Agency compliance information.....	6
FCC compliance statements	6
IC compliance statements	6
Radio Frequency (RF) statement	7
European Union Conformity	7
Restriction	7
Japanese Restrictions	7
2.4 Honeywell European (CE) Declaration of Conformity (DoC).....	8
For more information about the R&TTE Directive.....	10
2.5 IECEx Conditions of Certification.....	10
ATEX Conditions for Safe Use	10
3. PREPARATION	11
3.1 Installation	11
3.2 Configuration.....	11
3.3 Connecting to network	11
3.4 Calibrating the transmitter	11
Methods of calibration	11
User calibration	12
Wiring for calibration.....	14
Restore calibration.....	17
Clear calibration.....	18
4. FUNCTION BLOCKS.....	19
4.1 Introduction	19
4.2 Block description	19
Block types	19
Block diagram.....	19
4.3 Parameter details	20

- 5. OPERATION 21**
 - 5.1 Overview 21**
 - Transmitter display modes 21
 - Authentication Device 21
 - 5.2 Transmitter connection status..... 22**
 - 5.3 Transmitter PV display 23**
 - 5.4 Transmitter quick view of parameters 27**
 - 5.5 Transmitter menu 28**
 - Menu tree 28
 - 5.6 Authentication Device menus 29**
 - Overview 29
 - Main menu 29
 - Security and Node Deployment 30
 - Device Local Configuration 32
 - Read Node Information 33
 - Advanced Options 35

- 6. MAINTENANCE/REPAIR 36**
 - 6.1 Parts 36**
 - 6.2 Replacing batteries 37**
 - When to replace 37
 - Tools required 37
 - Procedure 37
 - 6.3 Replacing 24V external power module 39**
 - When to replace 39
 - Tools required 39
 - Procedure 39
 - 6.4 Replacing sensor module 41**
 - When to replace 41
 - Tools required 41
 - Procedure 41
 - 6.5 Replacing antenna 43**
 - Tools required 43
 - Procedure 43
 - 6.6 Replacing terminal board 46**
 - When to replace 46
 - Tools required 46
 - Procedure 46

Tables

Table 1 User calibration: T/C and RTD	12
Table 2 User calibration: Ohms (STTW400 only).....	13
Table 3 Calibration error messages	16
Table 4 Transmitter connection status	22
Table 5 Transmitter PV Display	23
Table 6 PV engineering units	23
Table 7 PV status	24
Table 8 Device status	24
Table 9 Menu tree.....	28
Table 10 Buttons for Device Local Configuration	32
Table 11 Read Node Information	33
Table 12 Advanced Options	35
Table 13: IS Battery Pack replacement procedure.....	38
Table 14 24V External power module	40
Table 15 Sensor module replacement.....	42
Table 16 Antenna replacement procedure	44
Table 17 Terminal board replacement procedure	46

Figures

Figure 1 XYR 6000 Temperature and Discrete Input Functional Diagram.....	3
Figure 2 Block Diagram	19
Figure 3 Main menu.....	29
Figure 4 Security and Node Deployment.....	30
Figure 5 Device Local Configuration screen.....	32
Figure 6 Read Node Information	33
Figure 7 Advanced Options	35
Figure 8: IS Battery Pack.....	38
Figure 9 24V Power Supply Module Assembly	39
Figure 10 Sensor module removal and replacement	42
Figure 11 Antenna replacement	45
Figure 12 Terminal board replacement	47

1. Introduction

1.1 Purpose

This manual describes the Honeywell OneWireless XYR 6000 Temperature/DI Transmitter function, operation and maintenance.

1.2 Scope

The manual includes:

- Details of topics that relate uniquely to the Honeywell XYR 6000 Temperature/DI Transmitter,
- This manual does not cover installation, mounting, or wiring. See XYR 6000 Transmitter Quick Start Guide (document 34-XY-25-21).

1.3 OneWireless network overview

OneWireless is an all digital, serial, two-way communication mesh network that interconnects industrial field sensors to a central system.

OneWireless has defined standards to which field devices and operator stations communicate with one another. The communications protocol is built as an "open system" to allow all field devices and equipment that are built to OneWireless standard to be integrated into a system, regardless of the device manufacturer. This interoperability of devices using OneWireless technology is to become an industry standard for automation systems.

1.4 About the transmitter

The XYR 6000 Temperature/DI Transmitter is furnished with OneWireless interface to operate in a compatible distributed OneWireless system. The transmitter will interoperate with any OneWireless registered device.

The transmitter includes OneWireless electronics for operating in a 2.4GHz network. It features function block architecture.

Inputs

The transmitter supports three input channels in various configurations depending on input types configured.

- Up to 3 thermocouple or millivolt channels (*STTW400*)
- Up to 2 RTD channels (*STTW400*)
- Channel 3 must be T/C or mV (*STTW400*)
- Channels 2 and 3 are discrete inputs (DI) and channel 1 is T/C or millivolt (*STTW401*)

continued

1. Introduction
1.4. About the transmitter

- Available input types
 - T/C (B, E, J, K, N, R, S, T)
 - RTD (Pt100, Pt200, Pt500)
 - mV (0 to 10, 0 to 50, 0 to 100)
 - Ohm (0 to 100, 0 to 200, 0 to 500, 0 to 1000)
 - Discrete (DI)

The input channels can be configured for the following input types by using the OneWireless User Interface with the corresponding device descriptor file:

Channel 1	Channel 2	Channel 3
RTD,Ohm	RTD,Ohm	not valid
RTD,Ohm	T/C,mV	not valid
T/C,mV	RTD,Ohm	not valid
RTD,Ohm	DI	not valid
DI	RTD,Ohm	not valid
T/C,mV	T/C,mV	T/C,mV
T/C,mV	T/C,mV	DI
T/C,mV	DI	T/C,mV
T/C,mV	DI	DI
DI	T/C,mV	T/C,mV
DI	T/C,mV	DI
DI	DI	T/C,mV
DI	DI	DI

Selecting any RTD/Ohm input renders Channel 3's input terminals unavailable and its PV and status invalid. Channel 3 should be set to Out of Service when using an RTD or Ohm input.

The transmitter measures the analog signal from temperature sensors, discrete inputs, millivolt values or ohm values and transmits a digital output signal proportional to the measured value for direct digital communications with systems.

The discrete input channels support voltage-free floating contacts. Maximum ON contact resistance is 300 ohms. Minimum OFF contact resistance is 5000 ohms.

The Process Variable (PV) is available for monitoring and alarm purposes. The cold junction temperature is also available as a fourth channel PV. Available PV update rates are 1, 5, 10, 30 seconds and are set using the Wireless Builder. Slower update rates extend battery life.

Figure 1 shows a block diagram of the XYR 6000 Temperature and Discrete Input transmitter's operating functions.

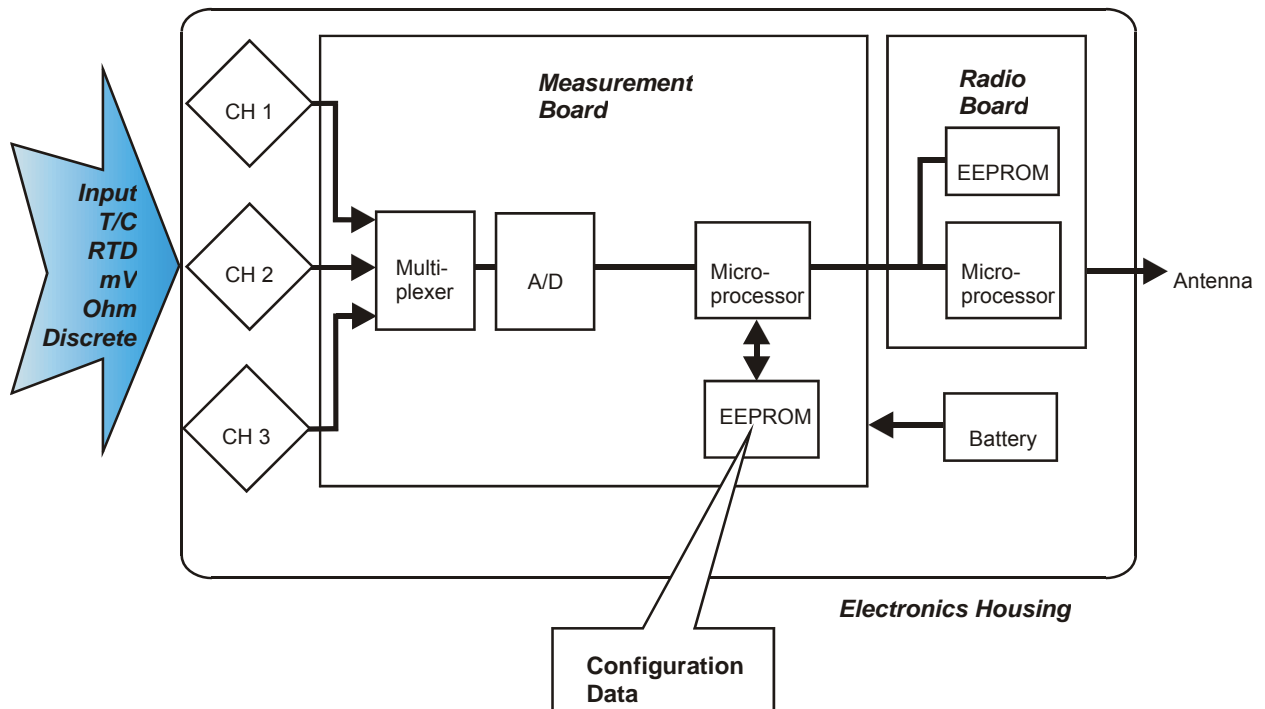

Figure 1 XYR 6000 Temperature and Discrete Input Functional Diagram

2. Specifications

2.1 European Union Usage





This product may be used in any of the following European Union nations.

Country	ISO 3166 2 letter code	Country	ISO 3166 2 letter code
Austria	AT	Latvia	LV
Belgium	BE	Liechtenstein	LI
Bulgaria	BG	Lithuania	LT
Cyprus	CY	Malta	MT
Czech Republic	CZ	Netherlands	NL
Denmark	DK	Norway	NO
Estonia	EE	Poland	PL
Finland	FI	Portugal	PT
France	FR	Romania	RO
Germany	DE	Slovakia	SK
Greece	GR	Slovenia	SI
Hungary	HU	Spain	ES
Iceland	IS	Sweden	SE
Ireland	IE	Switzerland	CH
Italy	IT	United Kingdom	BG

2.2 Certifications and approvals

Transmitter

See the product label for applicable approvals and ratings.

Approval / Item	Ratings / Description
CSAcus Intrinsically Safe	CL I, Div 1, Groups A, B, C, & D; CL II, Div 1, Groups E, F & G; CL III, T4 CL I, Zone 0: Ex ia IIC, T4; CL I, Zone 0: AEx ia IIC, T4
CSAcus Explosionproof	CL I, Div 1, Groups A, B, C, & D; CL II, Div 1, Groups E, F & G; CL III, T4 CL I, Zone 1: Ex d IIC, T4; CL I, Zone 1: AEx d IIC, T4
CSAcus Nonincendive	CL I, Div 2, Groups A, B, C & D; CL II, Div 2, Groups F & G; CL III, Div 2, T4 CL I, Zone 2: Ex nA IIC, T4; CL I, Zone 2: AEx nA IIC, T4
FM Approvals Intrinsically Safe	CL I, Div 1, Groups A, B, C, & D; CL II, Div 1, Groups E, F & G; CL III, T4 CL I, Zone 0: AEx ia IIC, T4
FM Approvals Explosionproof	CL I, Div 1, Groups A, B, C, & D; CL II, Div 1, Groups E, F & G; CL III, T4 CL I, Zone 1: AEx d IIC, T4
FM Approvals Nonincendive	CL I, Div 2, Groups A, B, C & D; CL II, Div 2, Groups F & G; CL III, Div 2, T4 CL I, Zone 2: AEx nA IIC, T4
HON – ATEX Non-Sparking	 II 3 GD , Ex nA IIC, T4; Ta = 85°C, Zone 2
KEMA 08 ATEX0062X Intrinsically Safe Flameproof Non-Sparking	 II 1 GD Ex ia IIB; T4 Ta = 70°C; Ex tD A20 IP66 T90°C  II 2 GD Ex d [ia] IIB; T4 Ta = 70°C; Ex tD A21 IP66 T90°C  II 3 GD Ex nA [nL] IIC; T4 Ta = 84°C; Ex tD A22 IP66 T90°C
IECEx CSA 09.0001X Intrinsically Safe Flameproof Non-Sparking	Ex ia IIB; T4 Ta = 70°C; DIP A20 IP66 T90°C Ex d [ia] IIB; T4 Ta = 70°C; DIP A21 IP66 T90°C Ex nA [nL] IIC; T4 Ta = 84°C; DIP A22 IP66 T90°C
Process Connections in Division 2 / Zone 2	 Division 2 / Zone 2 apparatus may only be connected to processes classified as non-hazardous or Division 2 / Zone 2. Connection to hazardous (flammable or ignition capable) Division 1 / Zone 0, or 1 process is not permitted.
Enclosure Type	Type 4X, IP 66
CRN	Canadian Registration Number
Class II and III installations and Type 4X/IP66 applications require that all cable and unused entries be sealed with a NRTL (National Recognized Testing Laboratory) listed cable gland or conduit plug. Cable glands and conduit plugs are not supplied with the product.	

2. Specifications

2.3. Agency compliance information

For detailed transmitter specifications see the following Specification and Model Selection Guide.

- XYR 6000 Wireless Transmitter Temperature/DI (document 34-XY-03-29)

Authentication Device

Install the Authentication Device application on any PDA having

- Windows Mobile version 4.2+
- Infrared port.

2.3 Agency compliance information

This section contains the Federal Communications Commission (FCC), Industry Canada (IC) and Radio Frequency compliance statements for the OneWireless XYR 6000 Wireless Transmitter device.



ATTENTION

XYR 6000 units must be professionally installed in accordance with the requirements specified in the *OneWireless XYR 6000 Agency Compliance Professional Installation Guide*.

FCC compliance statements

- This device complies with Part 15 of FCC Rules and Regulations. Operation is subject to the following two conditions: (1) This device may not cause harmful interference and (2) this device must accept any interference received, including interference that may cause undesired operation.
- This equipment has been tested and found to comply with the limits for a Class A digital device, pursuant to Part 15 of the FCC Rules. These limits are designed to provide reasonable protection against harmful interference in a residential installation. This equipment generates, uses, and can radiate radiofrequency energy and, if not installed and used in accordance with these instructions, may cause harmful interference to radio communications. Operation of this equipment in a residential area is likely to cause harmful interference in which case the user will be required to correct the interference at his own expense.
- Intentional or unintentional changes or modifications must not be made to the XYR 6000 Wireless Transmitters unless under the express consent of the party responsible for compliance. Any such modifications could void the user's authority to operate the equipment and will void the manufacturer's warranty.

IC compliance statements

- To reduce potential radio interference to other users, the antenna type and its gain should be so chosen that the equivalent isotropic radiated power (EIRP) is not more than that permitted for successful communication.
- Operation is subject to the following two conditions: (1) this device may not cause interference, and (2) this device must accept any interference, including interference that may cause undesired operation of the device.
- This Class A digital apparatus complies with Canadian ICES-003.
- French: Cet appareil numérique de la classe A est conforme à la norme NMB-003 du Canada.

Radio Frequency (RF) statement

To comply with FCC's and Industry Canada's RF exposure requirements, the following antenna installation and device operating configurations must be satisfied.

- Remote Point-to-Multi-Point antenna(s) for this unit must be fixed and mounted on outdoor permanent structures with a separation distance between the antenna(s) of greater than 20cm and a separation distance of at least 20cm from all persons.
- Remote Fixed Point-to-Point antenna(s) for this unit must be fixed and mounted on outdoor permanent structures with a separation distance between the antenna(s) of greater than 20cm and a separation distance of at least 100cm from all persons.
- Furthermore, when using integral antenna(s) the XYR 6000 Wireless Transmitter unit must not be co-located with any other antenna or transmitter device and have a separation distance of at least 20cm from all persons.

European Union Conformity

The XYR 6000 Wireless Transmitters are in conformity with the applicable portions of the ETSI standards as required by the R&TTE Directive 1999/5/EC.

Restriction

France restricts outdoor use to 10mW (10dBm) EIRP in the frequency range of 2,454-2,483.5 MHz. Installations in France must limit EIRP to 10dBm, for operating modes utilizing frequencies in the range of 2,454 – 2,483.5MHz.

Japanese Restrictions

For locations in Japan the transmitter power is restricted to 12.14dBm/Mhz {(32mW (15.4 dBm)] maximum EIRP including the antenna.

2. Specifications

2.4. Honeywell European (CE) Declaration of Conformity (DoC)

2.4 Honeywell European (CE) Declaration of Conformity (DoC)

This section contains the European Declaration of Conformity (DoC) statement, for the OneWireless product line.

R&TTE Directive	1999/5/EC	LVD Directive	73/23/EEC	EMC Directive	2004/108/EC	ATEX Directive	94/9/EC
Harmonized Standards							
EN 300 328 V1.7.1	Emissions Specification and Method:						
EN 301 893 V1.4.1	Emissions Spec and Method						
EN 301 489-17 V1.2.1	Immunity Specification:						
EN 301 489-1 V1.6.1	Immunity Method:						
IEC61326-1 : 2006	Electrical equipment for measurement, control and laboratory use – EMC requirements – Part 1: General requirements						
EN 60079-0 : 2006	Electrical apparatus for explosive gas atmospheres - Part 0: General requirements						
EN 60079-1 : 2004	Electrical apparatus for explosive gas atmospheres - Part 1: Flameproof enclosure 'd'						
EN 60079-11 : 2007	Electrical apparatus for explosive gas atmospheres - Part 11: Intrinsic safety 'i'						
EC 60079-15 : 2005	Electrical apparatus for explosive gas atmospheres - Part 15: Type of protection 'n'						
EN 61241-0 : 2007	Electrical apparatus for use in the presence of combustible dust - Part 0: General Requirements						
EN 61241-1 : 2004	Electrical apparatus for use in the presence of combustible dust - Part 1-1: Electrical apparatus for use in the presence of combustible dust – Part 1: Protection by enclosures "tD"						
Manufacturer's Name and Address	Honeywell Process Solutions 525 East Market Street, York, PA 17403 USA						
Compliance Statement	The product herewith complies with the harmonized standards listed above. Typical product line systems and configurations have been tested, for compliance.						

European Declaration of Conformity statements

Language	Statement
Česky (Czech):	Honeywell tímto prohlašuje, že tento XYR 6000 Wireless Transmitters je ve shodě se základními požadavky a dalšími příslušnými ustanoveními směrnice 1999/5/ES.
Dansk (Danish):	Undertegnede Honeywell erklærer herved, at følgende udstyr XYR 6000 Wireless Transmitters overholder de væsentlige krav og øvrige relevante krav i direktiv 1999/5/EF.
Deutsch (German):	Hiermit erkläre Honeywell , dass sich das Gerät XYR 6000 Wireless Transmitters in Übereinstimmung mit den grundlegenden Anforderungen und den übrigen einschlägigen Bestimmungen der Richtlinie 1999/5/EG befindet.
Eesti (Estonian):	Käesolevaga kinnitab Honeywell seadme XYR 6000 Wireless Transmitters vastavust direktiivi 1999/5/EÜ põhinõuetele ja nimetatud direktiivist tulenevatele teistele asjakohastele sätetele.
English	Hereby, Honeywell , declares that this XYR 6000 Wireless Transmitters is in compliance with the essential requirements and other relevant provisions of Directive 1999/5/EC.
Español (Spanish):	Por medio de la presente Honeywell declara que el XYR 6000 Wireless Transmitters cumple con los requisitos esenciales y cualesquiera otras disposiciones aplicables o exigibles de la Directiva 1999/5/CE.
Ελληνική (Greek):	ΜΕ ΤΗΝ ΠΑΡΟΥΣΑ Honeywell ΔΗΛΩΝΕΙ ΟΤΙ XYR 6000 Wireless Transmitters ΣΥΜΜΟΡΦΩΝΕΤΑΙ ΠΡΟΣ ΤΙΣ ΟΥΣΙΩΔΕΙΣ ΑΠΑΙΤΗΣΕΙΣ ΚΑΙ ΤΙΣ ΛΟΙΠΕΣ ΣΧΕΤΙΚΕΣ ΔΙΑΤΑΞΕΙΣ ΤΗΣ ΟΔΗΓΙΑΣ 1999/5/ΕΚ.
Français (French):	Par la présente Honeywell déclare que l'appareil XYR 6000 Wireless Transmitters est conforme aux exigences essentielles et aux autres dispositions pertinentes de la directive 1999/5/CE.
Italiano (Italian):	Con la presente Honeywell dichiara che questo XYR 6000 Wireless Transmitters è conforme ai requisiti essenziali ed alle altre disposizioni pertinenti stabilite dalla direttiva 1999/5/CE.
Latviski (Latvian):	Ar šo Honeywell deklarē, ka XYR 6000 Wireless Transmitters atbilst Direktīvas 1999/5/EK būtiskajām prasībām un citiem ar to saistītajiem noteikumiem.
Lietuvių (Lithuanian):	Šiuo Honeywell deklaruojama, kad šis XYR 6000 Wireless Transmitters atitinka esminius reikalavimus ir kitas 1999/5/EB Direktyvos nuostatas.
Nederlands (Dutch):	Hierbij verklaart Honeywell dat het toestel XYR 6000 Wireless Transmitters in overeenstemming is met de essentiële eisen en de andere relevante bepalingen van richtlijn 1999/5/EG.
Malti (Maltese):	Hawnhekk, Honeywell , jiddikjara li dan XYR 6000 Wireless Transmitters jikkonforma mal-ħtiġijiet essenzjali u ma provvedimenti oħrajn relevanti li hemm fid-Dirrettiva 1999/5/EC.
Magyar (Hungarian):	Alulírott, Honeywell nyilatkozom, hogy a XYR 6000 Wireless Transmitters megfelel a vonatkozó alapvető követelményeknek és az 1999/5/EC irányelv egyéb előírásainak.
Polski (Polish):	Niniejszym Honeywell oświadczam, że XYR 6000 Wireless Transmitters jest zgodny z zasadniczymi wymogami oraz pozostałymi stosownymi postanowieniami Dyrektywy 1999/5/EC.

2. Specifications

2.5. IECEx Conditions of Certification

Language	Statement
Português (Portuguese):	Honeywell declara que este XYR 6000 Wireless Transmitters está conforme com os requisitos essenciais e outras disposições da Directiva 1999/5/CE.
Slovensko (Slovenian):	Honeywell izjavlja, da je ta XYR 6000 Wireless Transmitters v skladu z bistvenimi zahtevami in ostalimi relevantnimi določili direktive 1999/5/ES.
Slovensky (Slovak):	Honeywell týmto vyhlasuje, že XYR 6000 Wireless Transmitters spĺňa základné požiadavky a všetky príslušné ustanovenia Smernice 1999/5/ES.
Suomi (Finnish):	Honeywell vakuuttaa täten että XYR 6000 Wireless Transmitters tyyppinen laite on direktiivin 1999/5/EY oleellisten vaatimusten ja sitä koskevien direktiivin muiden ehtojen mukainen.
Svenska (Swedish):	Härmed intygar Honeywell att denna XYR 6000 Wireless Transmitters står i överensstämmelse med de väsentliga egenskapskrav och övriga relevanta bestämmelser som framgår av direktiv 1999/5/EG.
Íslenska (Icelandic):	Hér með lýsir Honeywell yfir því að XYR 6000 Wireless Transmitters er í samræmi við grunnkröfur og aðrar kröfur, sem gerðar eru í tilskipun 1999/5/EC.
Norsk (Norwegian):	Honeywell erklærer herved at utstyret XYR 6000 Wireless Transmitters er i samsvar med de grunnleggende krav og øvrige relevante krav i direktiv 1999/5/EF.

For more information about the R&TTE Directive

The following website contains additional information about the Radio and Telecommunications Terminal Equipment (R&TTE) directive:

<http://ec.europa.eu/enterprise/rtte/faq.htm>

2.5 IECEx Conditions of Certification

Parts of the antenna are non-conducting and the area of the non-conducting part exceeds the maximum permissible areas for Category II 1 G (Zone 0) according to IEC 60079-0. Therefore when the antenna is used within a potentially explosive atmosphere, appropriate measures must be taken to prevent electrostatic discharge.

Impact and friction hazards need to be considered according to IEC 60079-0 when the transmitter that is exposed to the exterior atmosphere is made of light metal alloys, and used in Category II 1 G (Zone).

ATEX Conditions for Safe Use

Because the enclosure of the enclosure of the XYR 6000 Wireless Transmitter is made from aluminum, if it mounted in an area where the use of category 1G apparatus is required, it must be installed such that even in the event of rare incidents, ignition sources due to impact and friction sparks are excluded.

Special precautions shall be taken to prevent the surface of the antenna of the XYR 6000 Wireless Transmitter from being electrostatically charged

3. Preparation

3.1 Installation

Refer to the XYR 6000 Transmitter Quick Start Guide (document 34-XY-25-21) for installation, mounting and wiring of your XYR 6000 transmitter.

3.2 Configuration

The XYR 6000 Transmitter contains the electronics interface compatible for connecting to the OneWireless network. An operator uses the Wireless Builder application to configure blocks and to change operating parameters. These changes are written to the transmitter when it is authenticated by a security key.

3.3 Connecting to network

Use the Authentication Device to connect your transmitter to the OneWireless network. See page 30.

3.4 Calibrating the transmitter

Methods of calibration

Calibration can be done at the transmitter or at Wireless Builder's Method Manager. For all calibration methods at the transmitter, Wireless Builder must be used to unlock and take the channel out of service.

For the STTW401, calibration applies only to Thermocouple/millivolt input types, not the DI type.

- User calibration - Calibrates the channel to the low and high range values for the selected channel's input type.
- Restore calibration - Calibration constants for the selected channel are restored to factory defaults.
- Clear calibration - Factory or user calibration constants for the selected channel are cleared.

Additional calibration commands are available in Wireless Builder.

3. Preparation

3.4. Calibrating the transmitter

User calibration

Calibrates the channel to the default low and high range values for the channel's input type. Refer to the table for the input type desired.

Table 1 User calibration: T/C and RTD

Step	Action
1	In Wireless Builder, set the transmitter's Write Lock to UNLOCKED.
2	In Wireless Builder, set the transmitter's channel to OOS (Out of Service).
3	Loosen the M3 locking set screw on the transmitter's battery end-cap (opposite end from display). Unscrew and remove the end cap.
4	See page 14 for terminal connections. If your PV is connected to the channel, disconnect it first, and then connect a calibrator source to the channel's terminals. It is not necessary to disconnect any jumper wires on the terminals.
5	At the transmitter display, verify that the channel's number and PV value are not displayed. Use Authentication Device's Device Local Configuration buttons to navigate to the transmitter's CAL menu. If the transmitter is locked a LOCKED message will be displayed. Go to step 1. If CAL menu is passcode protected, enter the passcode. If the channel is not out of service a WRONG MODE message will be displayed. Go to step 2.
6	Select the channel for calibration (CH 1, CH 2 or CH 3). Select USER CAL. Follow displayed instructions. <ul style="list-style-type: none">• Using your calibration source, apply the low calibration value indicated on display. For TC apply cold junction compensated mV value. For RTD apply equivalent resistance value.• Press Enter to accept the value. Display will say BUSY, then CAL LO COMPLETE.• Press Enter to continue.• Apply the high calibration input value indicated on display.• Press Enter to accept the value. Display will say BUSY, then SUCCESS. Otherwise, the display will show one of the calibration error messages listed in Table 3.• Press Enter to return to PV display.
7	Repeat steps 1 through 6 for each channel you want to calibrate.
8	Reverse steps 3 and 4.
9	When ready, in Wireless Builder return the transmitter's channel to service and set Write Lock to LOCKED.

Table 2 User calibration: Ohms (STTW400 only)

Step	Action
1	In Wireless Builder, set the transmitter's Write Lock to UNLOCKED.
2	In Wireless Builder, set the transmitter's channel to OOS (Out of Service). Wait 20 seconds.
3	In Wireless Builder, do a Warm Start.
4	Loosen the M3 locking set screw on the transmitter's battery end-cap (opposite end from display). Unscrew and remove the end cap.
5	See page 14 for terminal connections. If your PV is connected to the channel, disconnect it first.
6	At the transmitter display, verify the channel's number and PV value are not displayed. Use Authentication Device's Device Local Configuration buttons to navigate to the transmitter's CAL menu. If the transmitter is locked a LOCKED message will be displayed. Go to step 1. If CAL menu is passcode protected, enter the passcode. If the channel is not out of service a WRONG MODE message will be displayed. Go to step 2.
7	You will need two 0-ohm wires (that is, two short wires) and one 1000-ohm resistor. The wires must be the same gauge as the resistor leads. <ul style="list-style-type: none"> • Select the channel for calibration (CH 1, CH 2). Select USER CAL. Display will say APPLY 0 OHMS. • For CH 1: Connect one short wire across terminals 1 and 2. Connect the other short wire across terminals 2 and 3. • For CH 2: Connect one short wire across terminals 4 and 5. Connect the other short wire across terminals 5 and 6. • Press Enter to accept the low value. Display will say BUSY, then CAL LO COMPLETE. • Press Enter to continue. Display will say APPLY 1000 OHMS. • For CH 1: Replace the short wire across terminals 1 and 2 with the 1000 ohm resistor. • For CH 2: Replace the short wire across terminals 4 and 5 with the 1000 ohm resistor. • Press Enter to accept the high value. Display will say BUSY, then SUCCESS. Otherwise, the display will show one of the calibration error messages listed in Table 3. • Press Enter to return to PV display.
8	Repeat steps 1 through 7 for each channel you want to calibrate.
9	Optional check (skip this step if desired): <ul style="list-style-type: none"> • With the calibration wiring still connected, use Wireless Builder to put the channel in AUTO mode. • Verify the PV for that channel is reading 1000 ohms. • Replace 1000 ohm wire with 0 ohm wire. Verify the PV for that channel is reading 0 ohms.
10	Remove calibration wiring and re-connect sensor wires.
11	When ready, in Wireless Builder return the transmitter's channel to service and set Write Lock to LOCKED.

3. Preparation
3.4. Calibrating the transmitter

Wiring for calibration



ATTENTION

When two wires will be installed in one screw terminal, both wires must be the same size (gauge) and construction (solid or stranded).

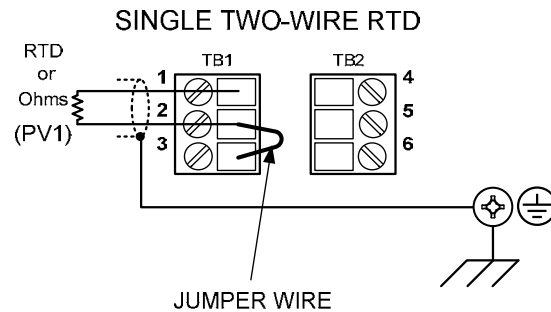
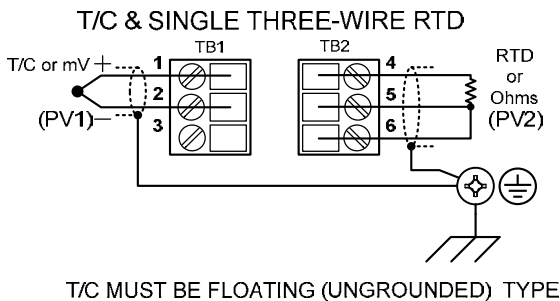
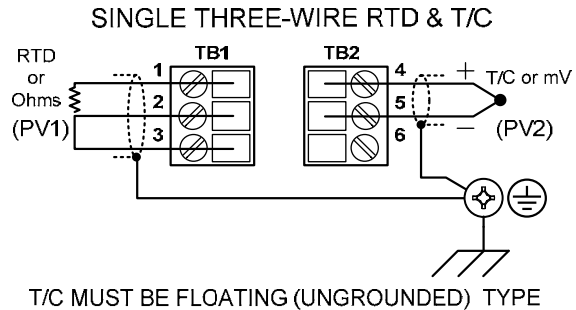
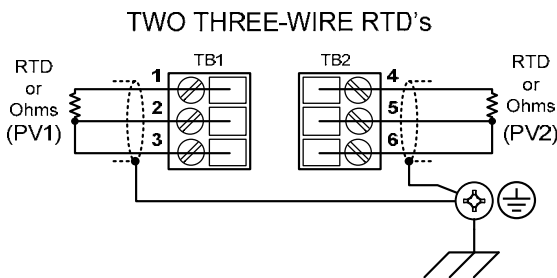
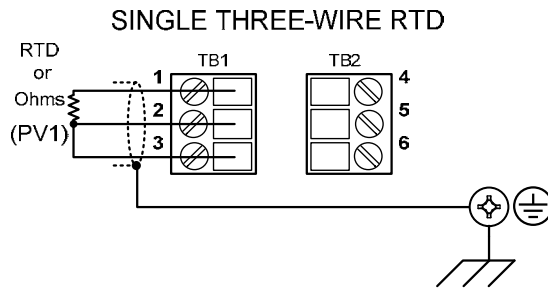
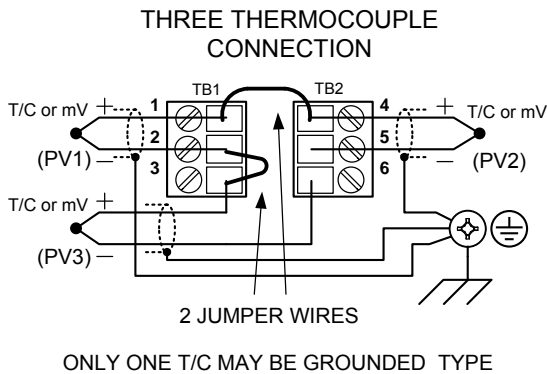
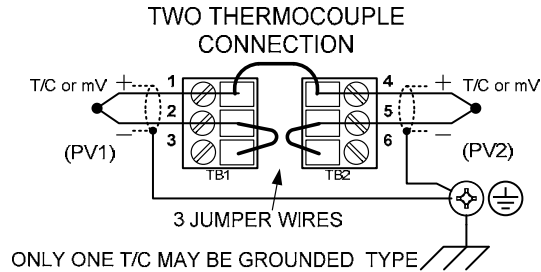
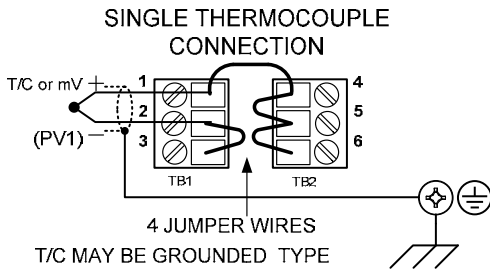

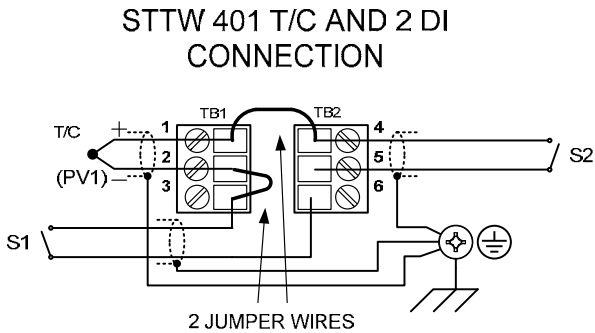
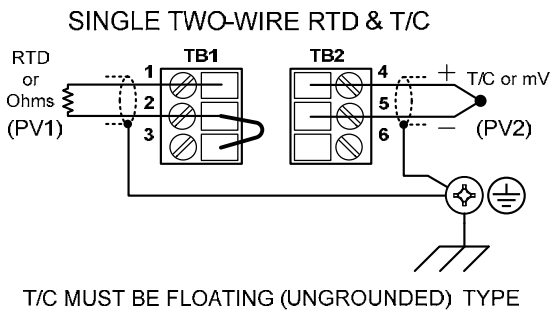
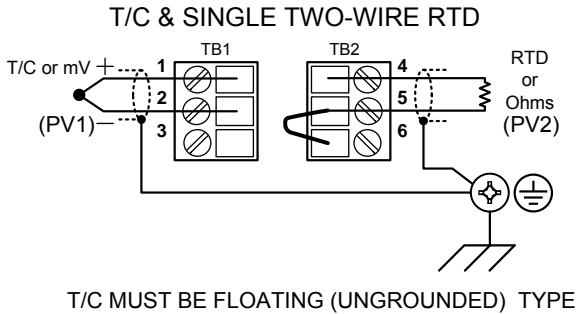
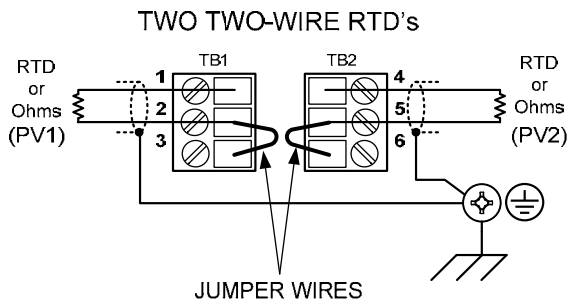

3. Preparation

3.4. Calibrating the transmitter

Table 3 Calibration error messages

Message	Meaning
CALIBRATION_FAIL	<ol style="list-style-type: none">1. Calibration gain is greater than 5%.2. Calibration offset is greater than 5% of sensor span. (TC span is in mV. RTD span is in Ohms.)
BAD_TRIM_POINT	CAL_POINT_HI is greater than sensor high range value OR CAL_POINT_LO is less than greater than sensor low range value.
BAD_USER_CALIBRATION	CAL_SOURCE is user and user calibration constants contain invalid values.
BAD_FACTORY_CALIBRATION	<ol style="list-style-type: none">1. CAL_SOURCE is factory and factory calibration constants do not contain valid values.2. CAL_RESTORE command was issued but factory calibration constants do not contain valid values.
BAD_SENSOR	Sensor is bad or faulty input thermocouple.
BAD_UNITS	Units in CAL UNITS parameter are invalid or not supported by the sensor type.
INTERNAL_ERROR	An error occurred during calibration that prevents calibration from being completed successfully.
SUCCESS_WITH_EXCESS	The calibration succeeded but the calculated calibration values are greater than 5 percent beyond the normal calibration values. Typically this indicates that the applied calibration value was significantly different from the expected value or that the sensor is not within expected tolerances for the applied characterization.

Restore calibration

Step	Action
1	In Wireless Builder, set the transmitter's Write Lock to Unlocked.
2	In Wireless Builder, set the transmitter's channel to OOS (Out of Service).
3	At the transmitter display, verify the channel's PV value is not displayed. Use Authentication Device's Device Local Configuration buttons to navigate to the transmitter's CAL menu. If CAL menu is passcode protected, enter the passcode. If the channel is not out of service a WRONG MODE message will be displayed. Go to step 2. If the transmitter is locked a LOCKED message will be displayed. Go to step 1.
4	Select the channel (CH 1, CH 2 or CH 3). Select CAL RSTR Press Enter to continue. Display will say BUSY, then SUCCESS. If unsuccessful the display will show BAD_FACTORY_CALIBRATION.
5	When ready, in Wireless Builder return the transmitter's channel to service and set Write Lock to Locked.

3. Preparation

3.4. Calibrating the transmitter

Clear calibration

Step	Action
1	In Wireless Builder, set the transmitter's Write Lock to Unlocked.
2	In Wireless Builder, set the transmitter's channel to OOS (Out of Service).
3	At the transmitter display, verify the channel's number and PV value is not displayed. Use Authentication Device's Device Local Configuration buttons to navigate to the transmitter's CAL menu. If CAL menu is passcode protected, enter the passcode. If the channel is not out of service a WRONG MODE message will be displayed. Go to step 2. If the transmitter is locked a LOCKED message will be displayed. Go to step 1.
4	Select the channel (CH 1, CH 2 or CH 3). Select CAL CLR Press Enter to continue. Display will say BUSY, then SUCCESS. Repeat for each channel desired.
5	When ready, in Wireless Builder return the transmitter's channel to service and set Write Lock to Locked.

4. Function blocks

4.1 Introduction

This section explains the construction and contents of the XYR 6000 Temperature/DI Transmitter Function Blocks.

4.2 Block description

Block types

Blocks are the key elements that make up the transmitter's configuration. The blocks contain data (block objects and parameters) which define the application, such as the inputs and outputs, signal processing and connections to other applications. The XYR 6000 Transmitter contains the following block types.

Block Type	Function
Device	Contains parameters related to the overall field device rather than a specific input or output channel within it. A field device has exactly one device block.
Transducer	Contains parameters related to a specific process input or output channel in a measurement or actuation device. A TB defines a measurement sensor channel for an analog process variable represented by a floating-point value. There is one TB per sensor.
Radio	Contains parameters related to radio communication between the transmitter and the multimode(s).

Block diagram

Figure 2 shows the blocks of the XYR 6000 Transmitter.

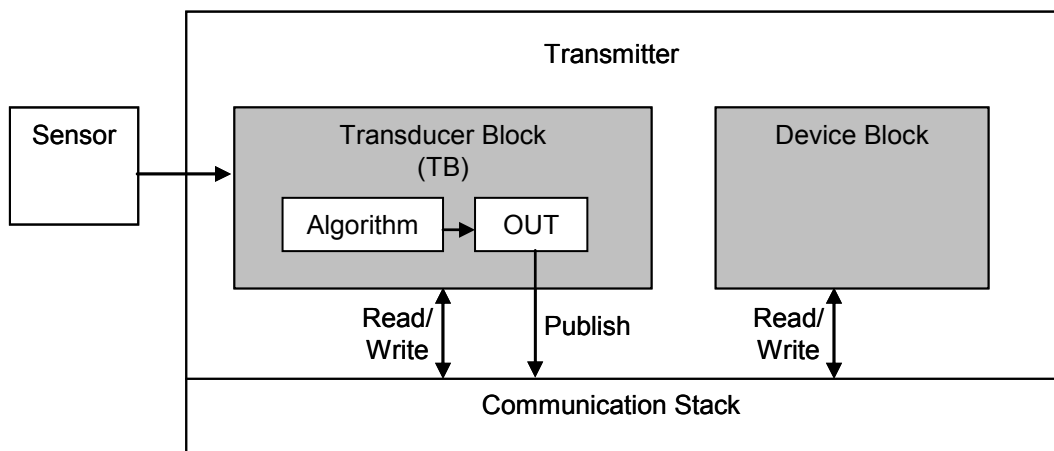

Figure 2 Block Diagram

Each of these blocks contains parameters that are standard OneWireless transmitter defined parameters. The Transducer and Device blocks contain standard parameters common to all XYR 6000 transmitter models (pressure, temperature, corrosion, HLAI, Multi DI) as well as model-specific parameters. The radio block contains parameters for communication with the wireless network.

4.3 Parameter details

The transmitter itself displays a few basic parameters, such as tag, serial number, device revision, build, device address and WFN ID by accessing the quick view mode using the Authentication Device navigation keys..

For more information on parameters, refer to the following documents.

- OneWireless Wireless Builder User's Guide
- OneWireless Parameter Reference

5. Operation

5.1 Overview

Transmitter display modes

The transmitter has the following display modes.

- Test. Appears briefly after power-up to self-test the display.
- Connection status. Appears when transmitter is not fully connected to the OneWireless network. See section 5.2.
- PV display. Default mode of the transmitter displays the PV and any status messages. See section 5.3 on page 23.
- Quick view of transmitter identification parameters. Displays read-only parameters then returns to PV display. See section 5.4 on page 27.
- Menu. See section 5.5 on page 28.

Authentication Device

To navigate the transmitter displays and menus, hold the Authentication Device no more than 6" (15 cm) from the transmitter and aim the infrared beam at the transmitter display while tapping the Device Local Configuration buttons (Table 10). You can also use the PDA's buttons.

Authentication Device menus are described in section 5.6 starting on page 29.

5.2 Transmitter connection status

Table 4 Transmitter connection status

Displayed status	Definition	What to do
NO KEY	Transmitter needs a key from the Authentication Device and is not transmitting.	Transmit a key to the transmitter. See page 30.
NOT CONN	Transmitter is in between discovery attempts.	<p>If Transmitter does not make a connection within five minutes, do the following:</p> <ul style="list-style-type: none"> • Check that Key is correct for the network you are trying to join. • Check that the Multinode(s) in the local area are turned on and are already a secure part of the network. • Check if KeyServer is active • Check the KeyServer Event Log to see if the Transmitter is actively trying to join. Errors in the Event Log show that the Transmitter is trying to join but that there are problems. Consult the Wireless Builder documentation for troubleshooting errors.
DISCOVER	Transmitter has not made a connection to a Multinode and is in discovery (searching for a connection to a Multinode). Transmitter will automatically enter a power saving mode if it cannot make a connection and will retry later.	Wait for connection. If Transmitter does not make a connection within five minutes, see NOT CONN in this table.
SECURING	Transmitter has connected with the network and is validating its key.	Wait for connection. If Transmitter does not make a connection within five minutes, see NOT CONN in this table.
CONNECTD	<p>For units with radio firmware build* 53 or higher.</p> <p>Transmitter has validated the key and has made a secure connection with at least two Multinode(s). Transmitter should appear in Wireless Builder as an uncommissioned device.</p> <p>For units with radio firmware build* 52.</p> <p>Transmitter has validated the key and has made a secure connection with at least one Multinode. Transmitter should appear in Wireless Builder as an uncommissioned device.</p>	<p>For units with radio firmware build* 53 or higher. No action required.</p> <p>For units with radio firmware build* 52. Transmitter will periodically look for a second Multinode in order to form a redundant connection to the network. If connected with only one Multinode Wireless Builder will display a Secondary Multinode Address of 0</p>
NO REDUN	Appears only on units with radio firmware build* 53 or higher. No redundancy, that is, Transmitter has connected with only one Multinode.	No action required. The Transmitter will periodically look for a second Multinode in order to form a redundant connection to the network
*Use the PDA to determine your radio firmware build number (page 21)		

5.3 Transmitter PV display

The following information is displayed in sequence for the first channel, second channel, etc. then repeating continuously unless another display mode (see Transmitter display modes on page 21) is selected.

Table 5 Transmitter PV Display

Item displayed	Example	Details
Channel number	1	Channel number 1, 2, or 3
PV value	350	Latest PV value.
PV engineering units	DEG F	See Table 6 on page 23.
PV status	BAD	See Table 7 on page 24. If PV status is not displayed then the PV value is good.
Device status	LOW BAT	See Table 8 on page 24. If multiple device status messages are in effect, they are displayed one message per channel until all messages have been displayed. If no device status is displayed then the device status is normal.

Table 6 PV engineering units

Engineering units	Description
Deg C	Degrees Celsius
Deg F	Degrees Fahrenheit
mV	Millivolts
Ohm	Ohms

Table 7 PV status

PV status	Cause – Action
(blank)	<ul style="list-style-type: none"> • PV is normal – no action required
BAD	<ul style="list-style-type: none"> • Possible calibration error – Clear calibration • Transducer Block can not execute due to internal firmware state – Attempt cold restart of device. • Transducer Block can not execute due to hardware fault – Replace sensor module. See page 36. • Sensor failure – Check the following. <ul style="list-style-type: none"> – connection between sensor board and terminal block – field wiring terminations on the terminal block – field sensor
UNC	<ul style="list-style-type: none"> • Warning: Input inaccurate due to uncertain input data integrity. • Warning: Input inaccurate due to input conversion limitations or resolution. • Warning: Input outside of characterized range. Value is estimated.

Table 8 Device status

Transmitter display	Wireless Builder display	Definition	What to do
OUT SVC	OOS	All channels are out of service.	Restore mode to Auto in Wireless Builder.
CAL ERR	Calibration Error	Calibration Data Invalid or could not be read.	Use Cal Clear, Restore, or User Calibrate.
LOW PWR	Low Power	External Power Critically Low	Check external 24V power supply
LOW BAT	Low Battery	Battery Voltage Critically Low	Replace batteries as soon as possible. See page 37.
NO RADIO	Radio Interprocessor Comm Error	Radio Board is not accessible.	Restart both the radio and sensor. If condition persists, replace sensor module. See page 36.
CJ FAIL	CJ Failure	Cold junction failure	Check connectors on Terminal Board and sensor module. Replace terminal board. See page 46.
BAD RADIO SPI	Sensor Radio SPI Communication Failure	Radio detected loss of communication with sensor board over the inter-processor communication link.	Restart both the radio and sensor. If condition persists, replace sensor module. See page 36.

Transmitter display	Wireless Builder display	Definition	What to do
BAD RADIO EEPROM	EEPROM SPI Communication Failure	Radio EEPROM SPI Communication failure	The radio will not be able to perform firmware upgrades but will operate normally using installed code. Replace sensor module. See page 36.
RADIO WDT RESET	WDT Reset Occurred	Radio Watch Dog Timeout detected	Restart both the radio and sensor. If condition persists, replace sensor module. See page 36.
BAD RADIO	Radio Circuitry Failure	Radio circuitry has failed	The radio processor detected error on internal radio circuitry. Replace sensor module. See page 36.
The following status messages have multiple meanings. Refer to Wireless Builder Device Status for exact cause.			
E FAIL	A/D Failure	Diagnostics detected defect with Analog to Digital Converter.	Replace sensor module. See page 36.
E FAIL	Electronics Failure	Electronic Failure detected on Sensor Board. Could be caused by one of the status items marked by *.	Restart both the radio and sensor. If condition persists, replace sensor module. See page 36.
E FAIL*	NVM Fault*	Startup diagnostics detected defect in Sensor Non-Volatile Memory	Replace sensor module. See page 36.
E FAIL*	Program Memory Fault*	Startup diagnostics detected defect in Sensor Read Only Memory	Replace sensor module. See page 36.
E FAIL*	RAM Fault*	Startup diagnostics detected defect in Processor Random Access Memory	Replace sensor module. See page 36.
INP FAIL	Input 1 Failure	Input 1 error	Check input 1 connection. Check input 1 configuration. Restart the sensor. If condition persists, replace sensor module. See page 36.
INP FAIL	Input 2 Failure	Input 2 error	Check input 2 connection. Check input 2 configuration. Restart the sensor. If condition persists, replace sensor module. See page 36.

Transmitter display	Wireless Builder display	Definition	What to do
INP FAIL	Input 3 Failure	Input 3 error	Check input 3 connection. Check input 3 configuration. Restart the sensor. If condition persists, replace sensor module. See page 36.
INP FAIL	Input Failure	Input Error	Possible meter body sensor failure.
INP FAIL	A/D Failure	Diagnostics detected defect with Analog to Digital Converter.	Replace sensor module. See page 36.
The following statuses are displayed only in the Wireless Builder Device Status.			
blank*	Device/Firmware Mismatch*	Sensor Board Firmware Error. The software did not pass verification tests.	Replace sensor module. See page 36.
blank*	Heap Memory Not Available*	Heap Allocation Failure. Software detected heap shortage and some communication packets may have been dropped.	Clear by warm restart of device. If condition persists contact Honeywell service.
blank	Input 1 T/C Warning	Faulty thermocouple, resistance excessive	Check input 1 connection and wiring. Replace thermocouple.
blank	Input 2 T/C Warning	Faulty thermocouple, resistance excessive	Check input 2 connection and wiring. Replace thermocouple.
blank	Input 2 Warning	Indeterminate discrete state at input	Check input 2 connection and wiring. Check input contacts.
blank	Input 3 T/C Warning	Faulty thermocouple, resistance excessive	Check input 3 connection and wiring. Replace thermocouple.
blank	Input 3 Warning	Indeterminate discrete state at input	Check input 3 connection and wiring. Check input contacts.
blank*	Watchdog Timer Error*	Sensor Watchdog Timeout. The processor was restarted due to unexpected operation.	Clear by warm restart of device. If condition persists contact Honeywell service.

5.4 Transmitter quick view of parameters

If the Up or Down key is pressed using the Authentication Device while in PV display mode, the display will enter parameter quick view mode. Successive presses of the Up key will increment to the next parameter in the following table, or exit to PV display mode if at the last parameter. The Down key will decrement to the previous parameter or exit if at the first parameter. The Enter key will exit to PV display mode at any time.

Position	Parameter	Description
1	Vendor Name	HONEYWELL
2	HONEYWELL	XYR 6000 MULTI AI DI DO
3	Tag Name	HON_XYR6000_MAIDIDO_1234567890
4	SDREV	Sensor device revision
5	SBLD	Sensor build number
6	Radio Type	DSSS
7	RBLD	Radio build number
8	WFN	Wireless field network identifier
9	NET	Network device address
10	MODE/CHANNEL	Frequency hopping mode & channel

5.5 Transmitter menu

Menu tree

At the PV display, press Enter to access the menus. To interact with the menus use the Device Local Configuration onscreen buttons (page 32) or the buttons on your PDA.

Table 9 Menu tree

Menu item	Description																																	
CAL	Calibration menu. May be password-protected. See Table 10 on page 32 for password number entry.																																	
CH-1	Channel 1.																																	
CH-2	Channel 2.																																	
CH-3	Channel 3.																																	
CAL RSTR	Restores selected channel to factory calibration.																																	
USER CAL	Lets you calibrate selected channel's low and high points.																																	
CAL CLR	Clear the factory and user calibration.																																	
EXIT	Exits calibration menu and returns to PV display.																																	
RADIO	Radio menu																																	
PRI RSSI	<p>Primary receive signal strength. Read only. Signal strength 00 is too weak to connect to the network.</p> <table border="1"> <thead> <tr> <th><u>Displayed Value</u></th> <th><u>Value dBm</u></th> <th><u>Rx Margin dB</u></th> </tr> </thead> <tbody> <tr> <td>00</td> <td>< -86</td> <td>< 10</td> </tr> <tr> <td>01</td> <td>-86 to -81</td> <td>10 to 15</td> </tr> <tr> <td>02</td> <td>-80 to -75</td> <td>16 to 21</td> </tr> <tr> <td>03</td> <td>-74 to -69</td> <td>22 to 27</td> </tr> <tr> <td>04</td> <td>-68 to -63</td> <td>28 to 33</td> </tr> <tr> <td>05</td> <td>-62 to -57</td> <td>34 to 39</td> </tr> <tr> <td>06</td> <td>-56 to -51</td> <td>40 to 45</td> </tr> <tr> <td>07</td> <td>-50 to -45</td> <td>46 to 51</td> </tr> <tr> <td>08</td> <td>-44 to -11</td> <td>52 to 85</td> </tr> <tr> <td>09</td> <td>≥ -10</td> <td>Saturation</td> </tr> </tbody> </table>	<u>Displayed Value</u>	<u>Value dBm</u>	<u>Rx Margin dB</u>	00	< -86	< 10	01	-86 to -81	10 to 15	02	-80 to -75	16 to 21	03	-74 to -69	22 to 27	04	-68 to -63	28 to 33	05	-62 to -57	34 to 39	06	-56 to -51	40 to 45	07	-50 to -45	46 to 51	08	-44 to -11	52 to 85	09	≥ -10	Saturation
<u>Displayed Value</u>	<u>Value dBm</u>	<u>Rx Margin dB</u>																																
00	< -86	< 10																																
01	-86 to -81	10 to 15																																
02	-80 to -75	16 to 21																																
03	-74 to -69	22 to 27																																
04	-68 to -63	28 to 33																																
05	-62 to -57	34 to 39																																
06	-56 to -51	40 to 45																																
07	-50 to -45	46 to 51																																
08	-44 to -11	52 to 85																																
09	≥ -10	Saturation																																
SEC RSSI	Secondary receive signal strength. Same as PRI RSSI. Read only.																																	
EXIT	Exit from Radio Menu																																	

5.6 Authentication Device menus

Overview

Hold the Authentication Device no more than 6" (15 cm) from the transmitter and aim the infrared beam at the transmitter display while tapping on the screen command or button.

Main menu

The main menu is shown below. Details start on the next page.



Figure 3 Main menu

Security and Node Deployment

Use this to:

- receive new security keys,
- transmit security keys for connecting the transmitter (or other nodes) to the OneWireless network,
- clear all security keys from the PDA,
- clear the transmitter's key and reset its configuration to factory default (such as for decommissioning).

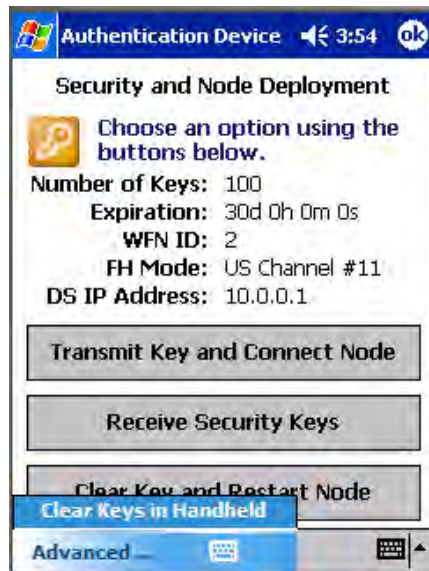
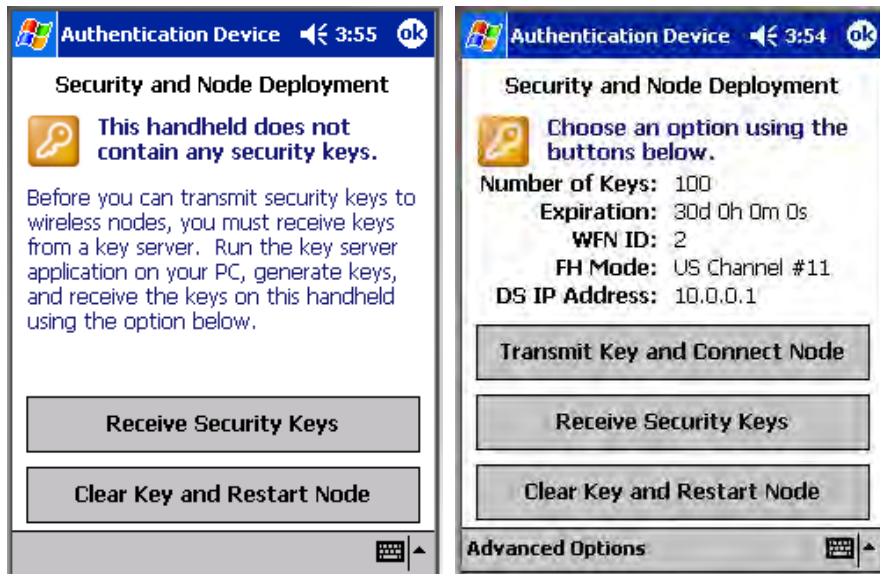

Figure 4 Security and Node Deployment

To connect your transmitter to the OneWireless network perform the following steps.

Step	Action
1	<p>If the PDA contains no keys, obtain new security keys from the PC application Key Server Manager.</p> <p>To do this, select Receive Security Keys. Keys can be received either through Infrared (by aiming PDA at the infrared dongle) or through an ActiveSync/USB connection. See Key Server Communication Method under Advanced options on page 35 for details.</p> <p>Important: The Comm Method settings must match in the PC's Key Server Manager and in the Authentication Device (both must be set to Infrared or both to ActiveSync) in order for your PDA to receive security keys. See Key Server Communication Method under Advanced options on page 35 for details.</p>
2	<p>When the Authentication Device has valid unexpired keys, aim it at the transmitter and transmit a key to the transmitter. The transmitter will validate the key and then use it to make a connection to the OneWireless Network. The Transmitter may continue to show the diagnostic message "NO KEY" for a brief time while it validates the key before showing the "DISCOVER" message.</p> <p>To verify your transmitter has been authenticated, see the Connection prompt on the Read Node Info screen (page 33).</p>

To decommission your transmitter from the OneWireless network, select **Clear Key and Restart Node**. This clears the transmitter's key, network and security configurations, and resets the transmitter to its factory default settings. perform the following steps.

Select **Clear Keys from Handheld** (under Advanced Options) when:

- The PDA has keys from one system, but you have moved your Authentication Device to another system, or
- you want to clear all keys so that you cannot deploy any more keys without going to the key server manager and getting more.

For more details on keys, refer to Getting Started with Honeywell OneWireless Solutions.

Device Local Configuration

Use Device Local Configuration buttons (Table 10) to navigate the transmitter menus (Table 9) and to make selections and changes. You can also use the PDA buttons.

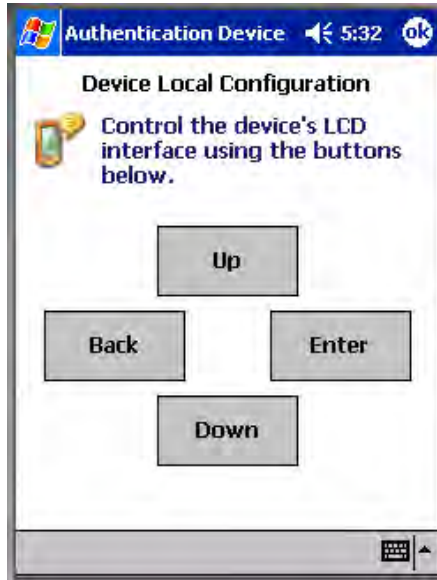

Figure 5 Device Local Configuration screen

Table 10 Buttons for Device Local Configuration

Button	Function
Enter	<ul style="list-style-type: none"> • Enter the Menu Tree. • Enter submenu of the menu that is appearing on the screen. • Execute action. • Submit the entered number while doing number entry. • Read value of certain displayed parameters.
Up	<ul style="list-style-type: none"> • Go to the next menu in the same level. • View quick view parameters in Normal Display Sequence (PV Display). • During number entry, increment the digit or change +/- sign.
Down	<ul style="list-style-type: none"> • Go to the previous menu in the same level. • View quick view parameters in Normal Display Sequence (PV Display). • During number entry, decrement the digit or change +/- sign.
Back	<ul style="list-style-type: none"> • Go to the upper menu level. • When changing a number value, move cursor to the left/more significant digit, then wrap around to the least significant digit.

Read Node Information

Use this to read the transmitter's information shown in Figure 6. Similar to quick view parameters on the transmitter display. (See page 27.)

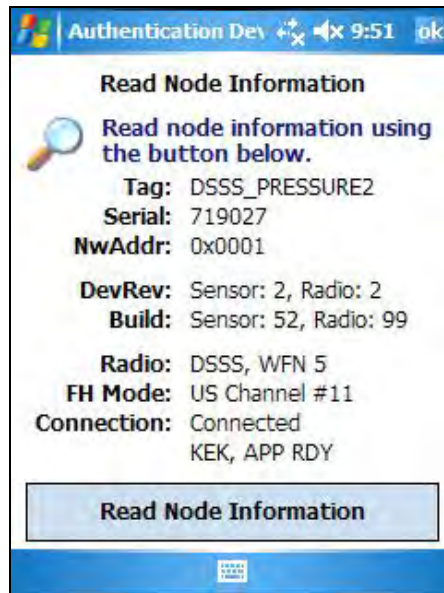

Figure 6 Read Node Information

Table 11 Read Node Information

Item	Description
Tag	The name given to this transmitter
Serial	Transmitter serial number. This is the WBSN on the transmitter's nameplate. Do not confuse this with the other nameplate item marked "Serial."
NwAddr	Network Address of the device in hexadecimal.
DevRev	Device Revision. This parameter changes whenever objects and parameters are added, deleted, or their data type or range changes. It does not change if the application firmware changes without affecting the device description. Range: 0 to 65535.
Build	Sensor firmware and radio firmware build numbers.
Radio	Hardware radio type, FHSS or DSSS WFN ID: Wireless Field Network ID. Range: 0 to 255.

Item	Description
FH Mode	<p>Frequency group or frequency channel selection used by the wireless network of the device. The value must match the value set in the gateway and interface nodes to allow communication between the device and the wireless network.</p> <p>Modes:</p> <ul style="list-style-type: none"> US Channel #1 US Channel #6 US Channel #11 US Guard Bands EU Channel #1 EU Channel #7 EU Channel #13 EU Guard Bands US/EU Spec Div A US/EU Spec Div B US/EU Channel #3 US/EU Channel #10 Complete Spectrum
Connection	<p>The first line displays one of the following connection states.</p> <p>No Security Key – No security key has been deployed to the device or multinode. The user must give a security key to the device or multinode before it will join the wireless sensor network.</p> <p>No Connection – A security key exists in the device or multinode, but no connection has been formed. The device or multinode is waiting to form a connection and will automatically retry shortly. Users may transmit a new security key in order to force the device or multinode to immediately retry to form a connection.</p> <p>Discovering – The device is attempting to form a connection to the wireless sensor network. The device is discovering multinodes and, if a multinode is found, will transition to the securing state.</p> <p>Securing – The device is attempting to form a connection to the wireless sensor network. The device has discovered one or two multinodes and is attempting to form a secure session. If successful, the device will transition to the connected state.</p> <p>Connected – A secure connection is formed with one or two multinodes.</p> <p>The second line contains detailed state information useful for problem reporting.</p>

Advanced Options

Advanced options are non-typical configuration commands.

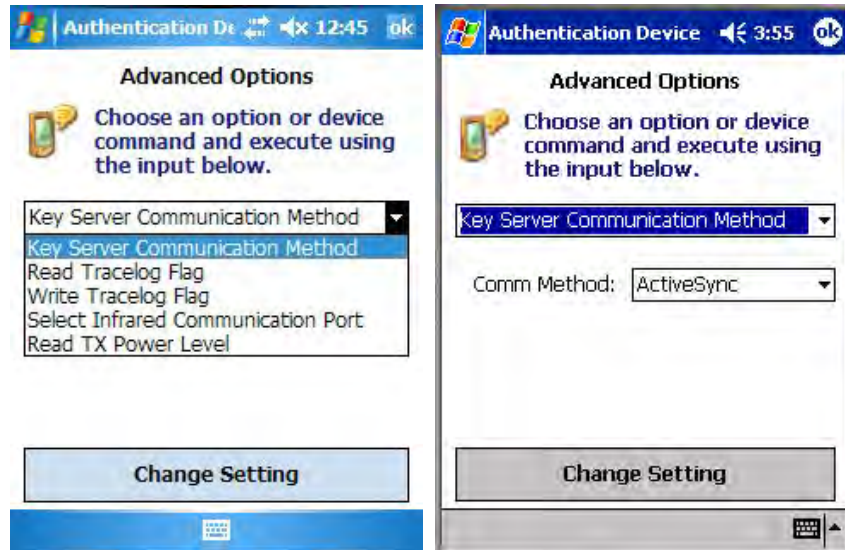

Figure 7 Advanced Options

Table 12 Advanced Options

Item	Description
Key Server Communication Method	<p>Determines how the PDA will receive security keys from the PC's Key Server Manager application. From the Comm Method menu select one of the following methods.</p> <p>ActiveSync – Select this to receive keys over a USB connection, such as while the PDA battery is being charged in its base.</p> <p>Infrared – Select this to receive keys over the infrared port.</p> <p>Important: The Comm Method settings match in the PC's Key Server Manager and in the Authentication Device (both must be set to Infrared or both to ActiveSync) in order for your PDA to receive security keys.</p>
Read Tracelog Flag	Not available for transmitters. Used with multinodes. Reads conditional tracelog flag value. Tracelog flags are used to enable and disable logging functionality used for field support.
Write Tracelog Flag	Not available for transmitters. Used with multinodes. Writes conditional tracelog flag value. Tracelog flags are used to enable and disable logging functionality used for field support .
Select Infrared Communication Port	Overrides the detected infrared communication port detected on your PDA. If infrared communication is not functioning, you can override the detected settings using this option.
Read TX Power Level	Reads the transmission power level of the transmitter radio.

6. Maintenance/Repair

6.1 Parts

The following replacement parts may be ordered from Honeywell.

Part number	Qty.	Description
50015866-501	1	ELECTRONICS MODULE ASSEMBLY aka SENSOR MODULE for Temperature
50015866-505	1	ELECTRONICS MODULE ASSEMBLY aka SENSOR MODULE for Temperature INTRINSICALLY SAFE
50015866-509	1	ELECTRONICS MODULE ASSEMBLY aka SENSOR MODULE for Temperature DSSS INTRINSICALLY SAFE
50015866-513	1	ELECTRONICS MODULE ASSEMBLY aka SENSOR MODULE for Temperature & DI FHSS INTRINSICALLY SAFE
50015866-514	1	ELECTRONICS MODULE ASSEMBLY aka SENSOR MODULE for Temperature & DSSS DISCRETE INPUT
50015866-517	1	ELECTRONICS MODULE ASSEMBLY aka SENSOR MODULE for Temperature & DI FHSS INTRINSICALLY SAFE
50015843-501	1	TERMINAL BOARD
50015623-501	1	CAP ASSEMBLY, BATTERY, ALUMINUM, DARK BEIGE
50016190-501	1	CAP ASSEMBLY, LCD, ALUMINUM, DARK BEIGE
50026009-501	1	CAP ASSEMBLY, BATTERY, STAINLESS STEEL
50026127-501	1	CAP ASSEMBLY, LCD, STAINLESS STEEL
50016229-501	1	ANTENNA ASSEMBLY, 2 dBi INTEGRAL RIGHT-ANGLE, ALUMINUM
50016229-502	1	ANTENNA ASSEMBLY, 2 dBi INTEGRAL RIGHT-ANGLE, STAINLESS STEEL
50020767-501	1	ANTENNA ASSEMBLY, 2 dBi INTEGRAL STRAIGHT, STAINLESS STEEL
50020767-502	1	ANTENNA ASSEMBLY, 2 dBi INTEGRAL STRAIGHT, ALUMINUM
50031715-501	1	ANTENNA ASSEMBLY, 4 dBi INTEGRAL RIGHT-ANGLE, ALUMINUM
50031715-502	1	ANTENNA ASSEMBLY, 4 dBi INTEGRAL RIGHT-ANGLE, STAINLESS STEEL
50018414-001	1	REMOTE OMNI-DIRECTIONAL ANTENNA, 8 dBi
50018415-001	1	REMOTE DIRECTIONAL ANTENNA, 14 dBi
50016577-502	1	ANTENNA ADAPTER ASSEMBLY, REMOTE, TYPE TNC, ALUMINUM
50028364-501	1	ANTENNA ADAPTER ASSEMBLY, REMOTE, TYPE N, ALUMINUM
50028364-502	1	ANTENNA ADAPTER ASSEMBLY, REMOTE, TYPE N, STAINLESS STEEL
50018110-001	1	COAX CABLE ASSY, 1.0M (3.3 Ft) LONG, RP-TNC - N-MALE
50018110-002	1	COAX CABLE ASSY, 3.0M (10.0 Ft) LONG, RP-TNC - N-MALE
50018110-003	1	COAX CABLE ASSY, 10.0M (33.0 Ft) LONG, RP-TNC - N-MALE
50018278-001	1	COAX CABLE ASSY, 1.0M (3.3 Ft) LONG, N-MALE - N-MALE
50018278-002	1	COAX CABLE ASSY, 3.0M (10.0 Ft) LONG, N-MALE - N-MALE
50018278-003	1	COAX CABLE ASSY, 10.0M (33.0 Ft) LONG, N-MALE - N-MALE
50018279-090	1	LIGHTNING SURGE ARRESTOR
50047517-501	1	BATTERY PACK HOUSING ASSEMBLY
50031428-501	1	24V EXTERNAL POWER MODULE
50026010-001	2	3.6V LITHIUM THIONYL CHLORIDE (Li-SOCI2) BATTERY

Part number	Qty.	Description
50026010-002	4	3.6V LITHIUM THIONYL CHLORIDE (Li-SOCI2) BATTERY
50026010-003	10	3.6V LITHIUM THIONYL CHLORIDE (Li-SOCI2) BATTERY

6.2 Replacing batteries

When to replace

When the transmitter displays a LOW BAT message you have 2-4 weeks to replace both batteries before they expire. When batteries are removed or expired, all transmitter data is retained in the transmitter's non-volatile memory.

Tools required

- #1 Phillips Screwdriver or 1/8" Slotted Screwdriver
- Torque Screwdriver
- 1.5 mm hex key

Procedure



ATTENTION

Batteries must be replaced only by a trained service technician.



WARNINGS

- Risk of death or serious injury by explosion. Do not open transmitter enclosure when an explosive gas atmosphere is present.
- Batteries must not be changed in an explosive gas atmosphere.
- If IS Battery Pack, Honeywell 50047517-001, has been installed in the Wireless Transmitter, the transmitter enclosure maybe opened when an explosive gas atmosphere is present. Otherwise, do not open transmitter enclosure when and explosive gas atmosphere is present.
 - When not in use the Battery Pack must be stored in a non Hazardous Area
- The batteries used in this device may present a risk of fire or chemical burn if mistreated. Do not recharge, disassemble, heat above 100°C (212°F), or incinerate.
- When installing batteries, do not snag the battery terminal on the clip or the battery may be damaged. Do not apply excessive force.
- Do not drop. Dropping the battery may cause damage. If a battery is dropped, do not install the dropped battery into the transmitter. Dispose of dropped battery promptly per local regulations or per the battery manufacturer's recommendations.



SHOCK HAZARD

Depending on your installation, transmitter input wiring sources may contain high voltage. Disconnect all power from transmitter input sources before accessing the batteries. Failure to do so could result in death or serious injury if the input terminals or wires are accidentally touched.

IS Battery Pack, 50047517-501

Table 13: IS Battery Pack replacement procedure

Step	Action
1	WARNING
	DO NOT DISASSEMBLE OR ASSEMBLE WHEN AN EXPLOSIVE ATMOSPHERE IS PRESENT

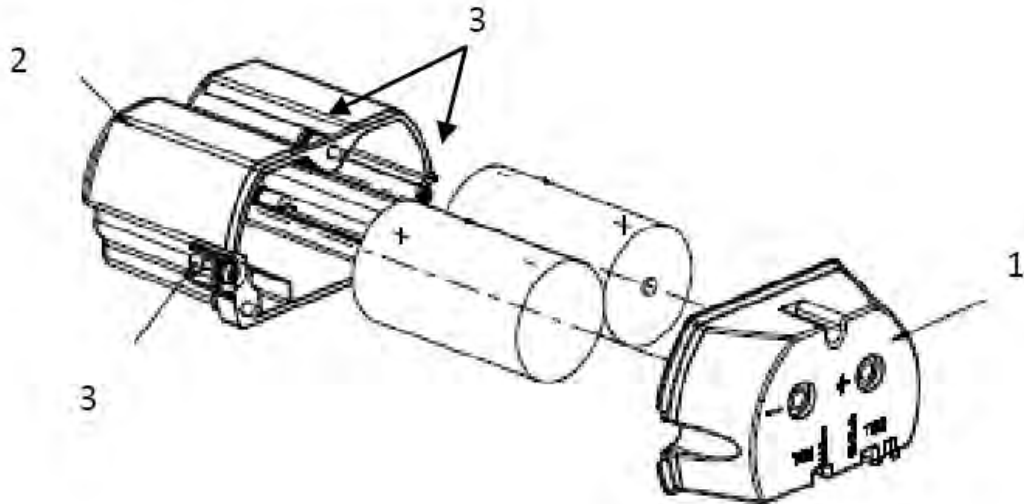

Figure 8: IS Battery Pack

- Loosen the M3 locking set screw on the battery end-cap (opposite end from display). See item 1 in Figure 1. Unscrew and remove the end cap.
- Using thumb and forefinger, squeeze the battery connector at top and bottom to disengage the locking mechanism, then pull to disconnect. See item 2 in Figure 1.
- Loosen the two battery holder retaining screws (closest to the batteries). See item 3 in Figure 1. The screws are captive.
- Pull the battery holder out of the transmitter.
- Remove top of battery pack by using a #1 Philips or 1/8" slotted screwdriver for the screws identified as #3 in Figure 8.
- Remove the old batteries and dispose of them promptly according to local regulations of the battery manufacturer's recommendations.
- Install the batteries following the polarity as noted on the lid
- Re-install top of the battery pack and tighten screws
- Insert the Battery pack into the transmitter. Reattach the screws as indicated in Figure 8, item 3, to 0.4 to 0.6 N-M (3.5 – 5.3 Lb-in).
Reconnect the Battery Pack connector
Honeywell recommends lubricating the end cap with a silicone grease such as Dow Corning #55 or equivalent before replacing the end cap
- Screw the cap back on and tighten the M3 locking screw

6.3 Replacing 24V external power module

When to replace

When the transmitter displays LOW PWR and external power is present and sufficient. When the external power is removed to allow replacement of the module, all transmitter data is retained in the transmitter's nonvolatile memory.

Tools required

- #1 Phillips Screwdriver or 1/8" Slotted Screwdriver
- Torque Screwdriver
- 1.5 mm hex key

Procedure



ATTENTION

24V power module must be replaced only by a trained service technician.



WARNINGS

- Risk of death or serious injury by explosion. Do not open transmitter enclosure when an explosive gas atmosphere is present.
-



SHOCK HAZARD

- Depending on your installation, transmitter input wiring sources may contain high voltage. Disconnect all power from transmitter input sources before accessing the 24V power module. Failure to do so could result in death or serious injury if the input terminals or wires are accidentally touched.
-

Figure 9 24V Power Supply Module Assembly

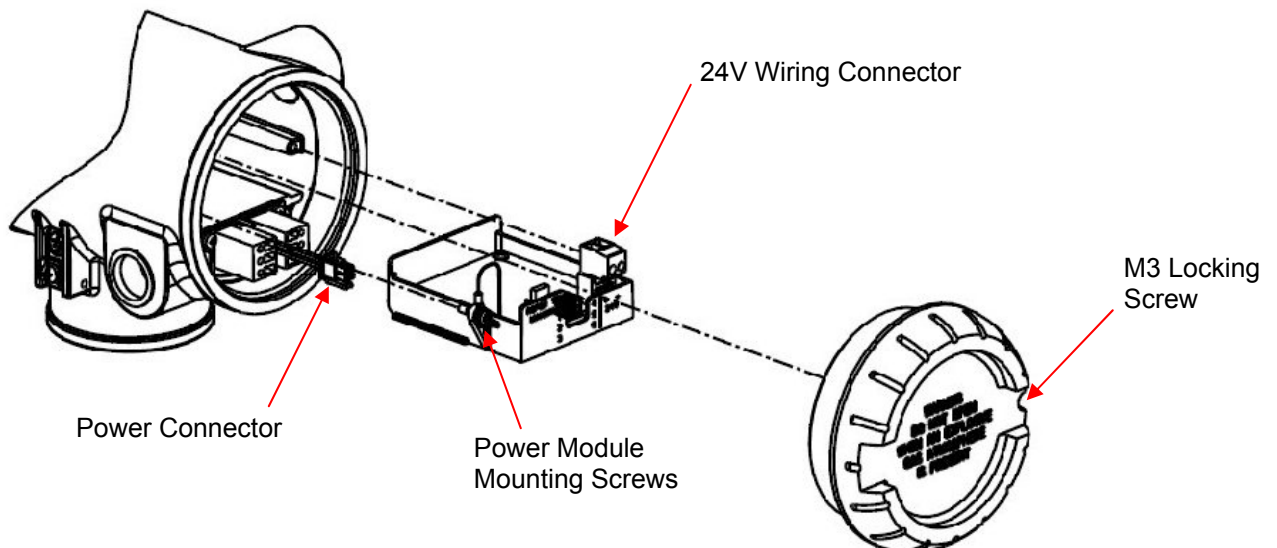
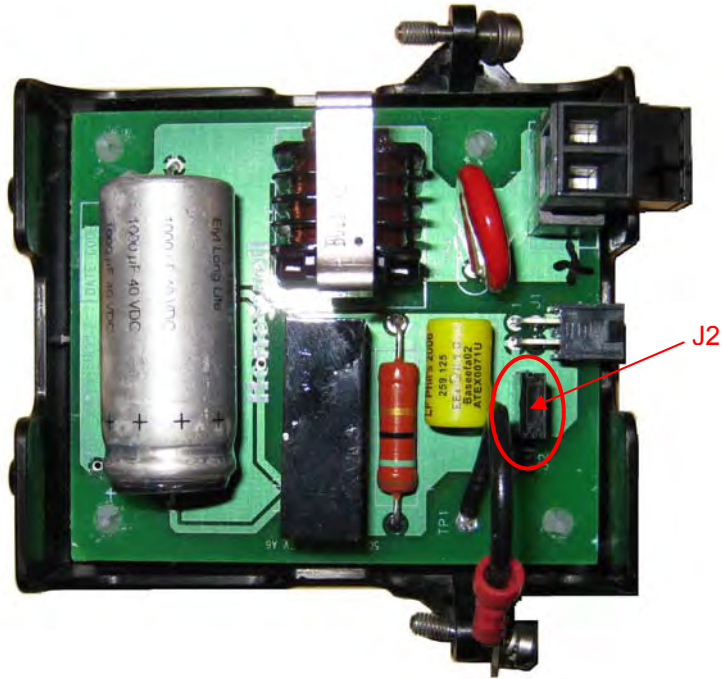

Table 14 24V External power module



Step	Action
1	Loosen the M3 locking set screw on the end-cap (opposite end from display). See Figure 9. Unscrew and remove the end cap.
2	Using thumb and forefinger squeeze the power connector at top and bottom to disengage the locking mechanism then pull to disconnect. See Figure 9.
3	Unplug the 24V wiring from the module
4	Loosen the two 24V power module retaining screws. The screws are captive.
5	Pull the 24V power module out of the transmitter.
6	The replacement 24V Power Modules are supplied with the “J2” Jumper in the NON-RTD position. For 24V Transmitters utilizing RTD sensors, move the “J2” jumper to the “RTD” position on the power module shown above in Table 14.
7	Insert the replacement 24V power module into the transmitter. Reattach the screws and tighten to 0,4 – 0,6 N-M (3.5 – 5.3 Lb-in). Re-connect battery connector.
	Honeywell recommends lubricating the end cap O-ring with a Silicone Grease such as Dow Corning #55 or equivalent before replacing the end cap.
8	Screw the end cap back on and tighten the M3 locking screw.
9	Dispose of the Power Module according to local regulations

6.4 Replacing sensor module

When to replace

Various error messages can help you diagnose a faulty module. These are described elsewhere in this manual.

Tools required

- #1 Phillips Screwdriver or 1/8" Slotted Screwdriver
- Torque Screwdriver
- 1.5 mm hex key

Procedure



WARNING

Risk of death or serious injury by explosion. Do not open transmitter enclosure when an explosive gas atmosphere is present.



CAUTION

Take precautions against electrostatic discharge to prevent damaging the sensor module.

Table 15 Sensor module replacement

Step	Action
1	Honeywell recommends that the transmitter be removed from service and moved to a clean area before servicing.
2	Loosen the M3 locking set screw on the display end-cap. See item 1 in Figure 10. Unscrew and remove the end cap.
3	Loosen the two screws on the sensor module. See items 2 in Figure 10.
4	Disconnect each connector on the sensor module. See items 3 in Figure 10.
5	Install new sensor module. Be sure to orient sensor module in the proper viewing orientation before tightening two sensor compartment screws.
	Reverse steps 1-4.
	Torque screws to 0,4 – 0,6 N-M (3.5 – 5.3 Lb-in).
	Honeywell recommends lubricating the end cap O-ring with a Silicone Grease such as Dow Corning #55 or equivalent before replacing the end cap.
6	Clean the transmitter's nameplate and affix WBSN label over the existing WBSN (Wireless Builder Serial Number).
7	Return transmitter to service.

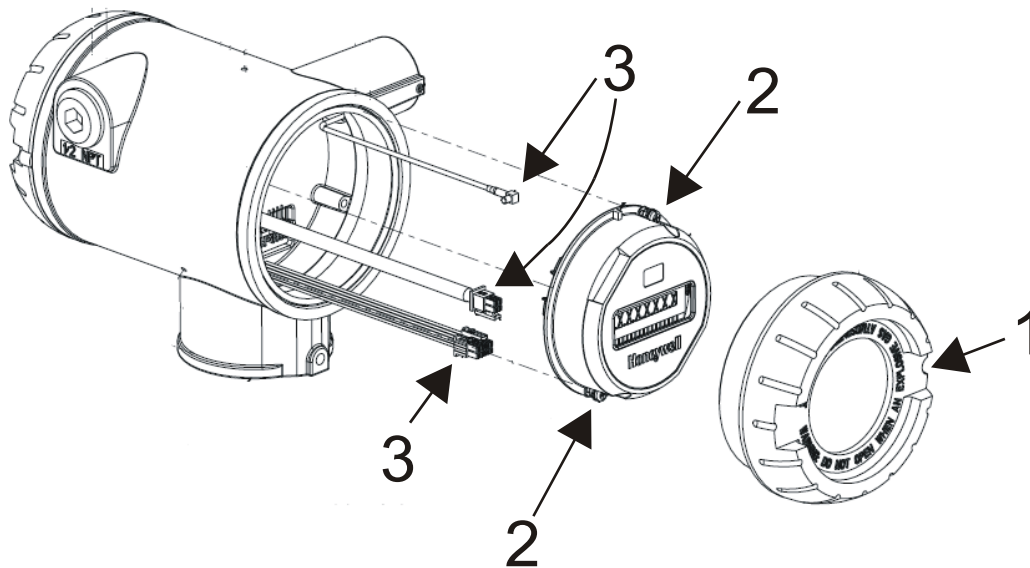

Figure 10 Sensor module removal and replacement

6.5 Replacing antenna

Tools required

- #1 Phillips Screwdriver or 1/8" Slotted Screwdriver
- Torque Screwdriver
- 1.5 mm hex key

Procedure



ATTENTION

You must replace your antenna with the same type, that is, right-angle, straight, or remote. Changing to a different antenna type is not permitted by approval agencies.



CAUTION

Take precautions against electrostatic discharge to prevent damaging the sensor module.



WARNING

POTENTIAL ELECTROSTATIC CHARGING HAZARD

The integrally mounted antenna shroud is made of Teflon® and has a surface resistance greater than 1Gohm per square. When the XYR 6000 transmitter is installed in potentially hazardous locations care should be taken not to electrostatically charge the surface of the antenna shroud by rubbing the surface with a cloth, or cleaning the surface with a solvent. If electrostatically charged, discharge of the antenna shroud to a person or a tool could possibly ignite a surrounding hazardous atmosphere.

Table 16 Antenna replacement procedure

Step	Action
1	Honeywell recommends that the transmitter be removed from service and moved to a clean area before servicing.
2	Loosen the M3 locking set screw on the display end-cap. See item 1 in Figure 11. Unscrew and remove the front end cap.
3	Loosen the two screws on the sensor module. See items 2 in Figure 11.
4	Remove the sensor module from the transmitter body and disconnect the antenna connector from CN2 connector on the sensor module. See item 3 in Figure 11.
5	Loosen the locking set screw at the antenna base. Unscrew the antenna from the transmitter. Remove the antenna and its connector from the transmitter.
6	Feed the new antenna's connector through the antenna hole to the front of the transmitter. Do not connect to sensor module yet. Lubricate with Silicone Grease such as Dow Corning #55. Screw new antenna into transmitter body until finger-tight, then back off 180 degrees to permit adjustment later.
7	Attach antenna connector to CN2 connector on sensor module.
8	Insert sensor module. Orient in the proper viewing orientation before tightening two sensor compartment screws. See items 2 in Figure 11. Torque screws to 0,4 – 0,6 N-M (3.5 – 5.3 Lb-in).
9	Replace the front end cap. Honeywell recommends lubricating the front end cap O-ring with a Silicone Grease such as Dow Corning #55 or equivalent before replacing the end cap.
10	Adjust antenna for best reception. Don't rotate antenna more than 180 degrees either direction or you could twist and break the antenna wiring inside. Tighten the antenna locking set screw.

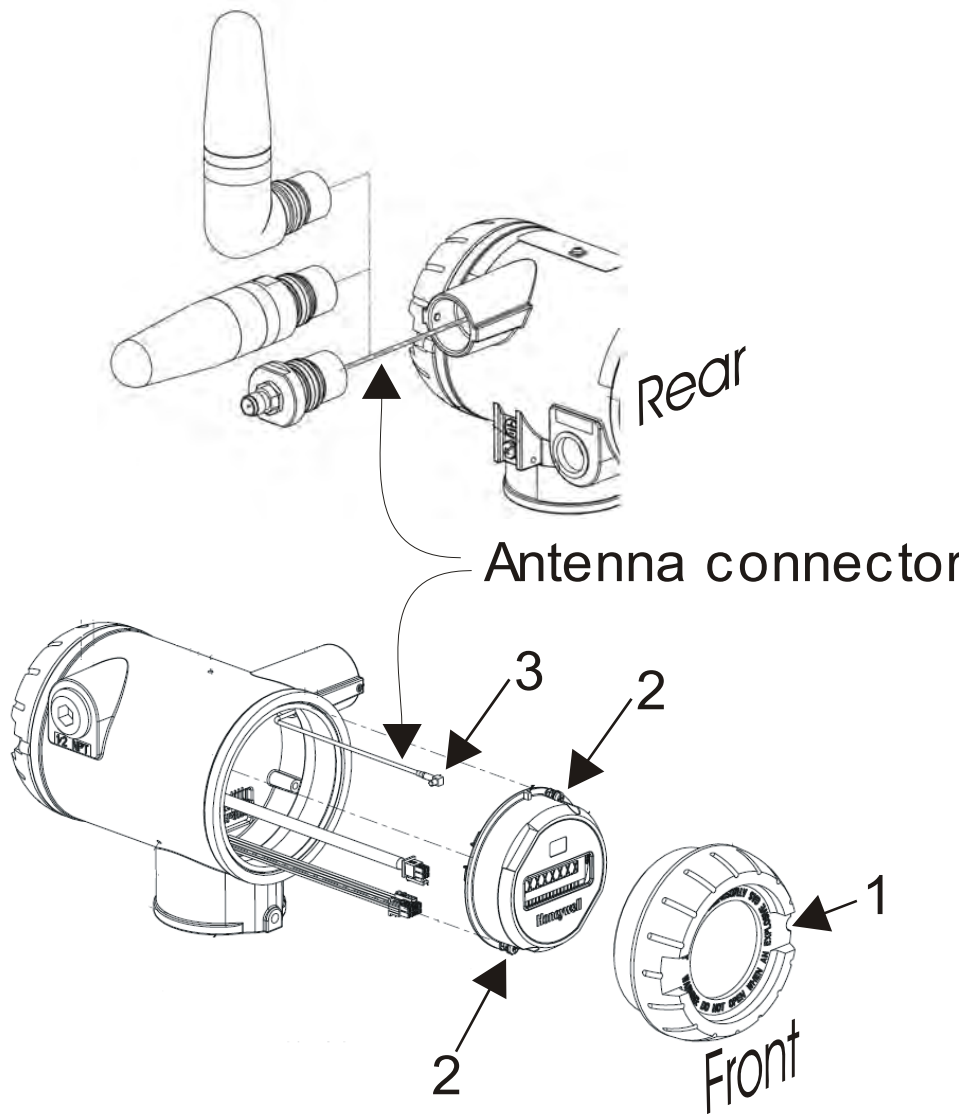

Figure 11 Antenna replacement

6.6 Replacing terminal board

When to replace

Various error messages can help you diagnose a faulty terminal board. These are described elsewhere in this manual.

Tools required

- #1 Phillips Screwdriver or 1/8" Slotted Screwdriver
- Torque Screwdriver
- 1.5 mm hex key

Procedure



WARNING

Risk of death or serious injury by explosion. Do not open transmitter enclosure when an explosive gas atmosphere is present.

Table 17 Terminal board replacement procedure

Step	Action
1	Honeywell recommends that the transmitter be removed from service and moved to a clean area before servicing.
	 SHOCK HAZARD Depending on your installation, transmitter input wiring sources may contain high voltage. Disconnect all power from transmitter input sources before accessing the terminal board. Failure to do so could result in death or serious injury.
2	Loosen the M3 locking set screw on the battery end-cap (opposite end from display). See item 1 in Figure 12. Unscrew and remove the end cap.
3	Using thumb and forefinger, squeeze the battery connector at top and bottom to disengage the locking mechanism, then pull to disconnect. See item 2 in Figure 12.
4	Loosen the two battery holder retaining screws (closest to the batteries). See item 3 in Figure 12. The screws are captive.
5	Pull the battery holder out of the transmitter.

- | Step | Action |
|------|--|
| 6 | Disconnect field wiring from terminal board and label it to ease reconnection. |
| 7 | Remove and save the 3 screws that attach the terminal board to the housing. Take care because these screws are not captive. See item 4 in Figure 12. |
| 8 | Remove terminal board by disconnecting cable from back of the terminal board. Do not pull on the wires or you could damage them. Instead, depress the latch while pulling on the connector. |
| 9 | Attach connector to new terminal board. Observe correct polarity of the connector. Verify that the cable is latched to the terminal board. |
| 10 | Fasten terminal board with screws from step 7. |
| 11 | Re-connect field wiring. |
| 12 | Insert the battery holder into the transmitter. Reattach the screws and tighten to 0,4 – 0,6 N-M (3.5 – 5.3 Lb-in).

Re-connect battery connector.

Honeywell recommends lubricating the end cap O-ring with a Silicone Grease such as Dow Corning #55 or equivalent before replacing the end cap. |
| 13 | Screw the end cap back on and tighten the M3 locking screw. |

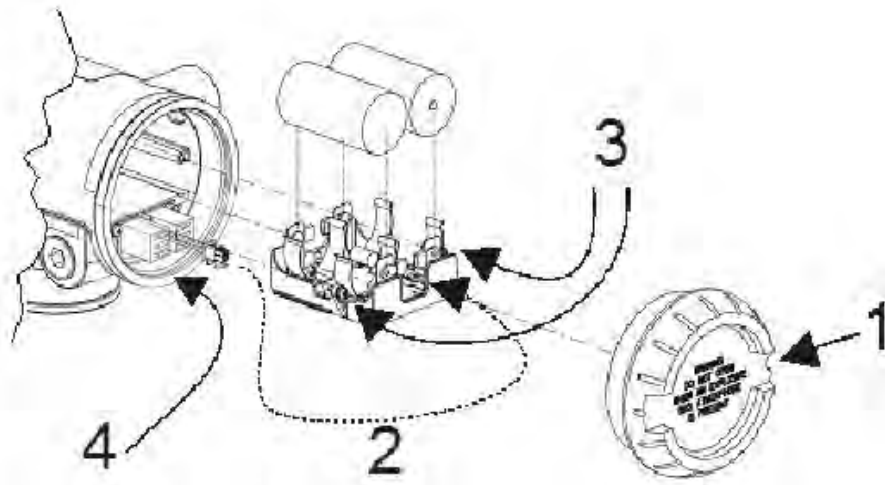

Figure 12 Terminal board replacement

Sales and Service

For application assistance, current specifications, pricing, or name of the nearest Authorized Distributor, contact one of the offices below.

ASIA PACIFIC

Control Products
Asia Pacific Headquarters
Phone: +(65) 6355-2828
Fax: +(65) 6445-3033

Asia Pacific Global Technical Support

Field Instruments
Phone: +65 6580 3156
Fax: +65 6445-3033
Process Instruments
Phone: (603) 76950 4777
Fax: (603) 7958 8922

Australia

Honeywell Limited
Phone: +(61) 7-3846 1255
FAX: +(61) 7-3840 6481
Toll Free 1300-36-39-36
Toll Free Fax:
1300-36-04-70

China – PRC - Beijing

Honeywell China Inc.
Phone: +(86-10) 8458-3280
Fax: +(86-10) 8458-4650

China – PRC - Shanghai

Honeywell China Inc.
Phone: (86-21) 5257-4568
Fax: (86-21) 6237-2826

China – PRC - Chengdu

Honeywell China Inc.
Phone: +(86-28) 8678-6348
Fax: +(86-28) 8678-7061

China – PRC - Xi'an

Honeywell China Ltd - Xi'an.
Phone: +(86-29) 8833-7490
Fax: +(86-29) 8833-7489

China – PRC - Shenzhen

Honeywell China Inc.
Phone: +(86) 755-2518-1226
Fax: +(86) 755-2518-1221

Indonesia

PT Honeywell Indonesia
Phone: +(62) 21-535-8833
FAX: +(62) 21-5367 1008

India Automation India Ltd.

Honeywell Ltd.
Phone: +(91) 5603-9400
Fax: +(91) 5603-9600

Japan

Honeywell Inc.
Phone: +(81) 3 6730 7150
Fax: +(81) 3 6730 7228

Malaysia

Honeywell Engineering Sdn Bhd
Phone: +(60-3) 7950-4776
Fax: +(60-3) 7958-8922

New Zealand

Honeywell Limited
Phone: +(64-9) 623-5052
Fax: +(64-9) 623-5060
Toll Free (0800) 202-088

Philippines

Honeywell Systems (Philippines) Inc.
Phone: +(63-2) 633-2830-31/
636 1661-62
Fax: +(63-2) 638-4013

Singapore

Honeywell Pte Ltd.
Phone: +(65) 6580 3278
Fax: +(65) 6445-3033

South Korea

Honeywell Korea Co Ltd
Phone: +(822) 799 6315
Fax: +(822) 792 9015

Thailand

Honeywell Systems (Thailand) Ltd.
Phone: +(662) 693-3099
FAX: +(662) 693-3089

Taiwan R.O.C.

Honeywell Taiwan Ltd.
Phone: +(886-2) 2245-1000
FAX: +(886-2) 2245-3241

SE Asia Countries

see Honeywell Pte Ltd (Singapore)
for: Pakistan, Cambodia, Guam, Laos, Myanmar, Vietnam, East Timor

SE Asia Countries

see Honeywell Automation India Ltd for: Bangladesh, Nepal, Sri Lanka

EUROPE

Austria

Honeywell Austria GmbH
Phone: +43 (316)400123
FAX: +43 (316)40017

Belgium

Honeywell SA/NV
Phone: +32 (0) 2 728 24 07
FAX: +32 (0) 2 728 22 45

Bulgaria

Honeywell EOOD
Phone: +(359) 2 40 20 900
FAX: +(359) 2 40 20 990

Czech Republic

Honeywell spol. s.r.o.
Phone: +420 242 442 232
FAX: +420 242 442 131

Denmark

Honeywell A/S
Phone: +(45) 39 55 55 55
FAX: +(45) 39 55 55 58

Finland

Honeywell OY
Phone: +358 (0)20752 2753
FAX: +358 (0) 20752 2751

France

Honeywell SA
Phone: +33 (0)1 60198075
FAX: +33 (0)1 60198201

Germany

Honeywell AG
Phone: +49 (69)8064-299
FAX: +49 (69)806497336

Hungary

Honeywell Kft.
Phone: +36-1-451 4300
FAX: +36-1-451 4343

Italy

Honeywell S.p.A.
Phone: +390292146307
FAX: +39 0292146377

The Netherlands

Honeywell B.V.
Phone: +31 (0) 20 5656200
FAX: +31 (0) 20 5656210

Norway

Honeywell A/S
Phone: (45) 39 55 55 55

Poland

Honeywell Sp. zo.o
Phone: +48-22-6060900
FAX: +48-22-6060901

Portugal

Honeywell Portugal Lda
Phone: +351 21 424 5000
FAX: +351 21 424 50 99

Romania

Honeywell Bucharest
Phone: +40 (0) 21 2316437
FAX: +40 (0) 21 2316439

Russian Federation (RF),

ZAO "Honeywell"
Phone: +7 (095) 796 98 00
FAX: +7 (495) 797 99 64

Slovak Republic

Honeywell s.r.o.
Phone: +421-2-58247 410
FAX: +421-2-58247 415

Spain

Honeywell S.A.
Phone: +34 (0)91313 61 00
FAX: +34 (0)91313 61 30

Sweden

Honeywell AB
Phone: +(46) 8 775 55 00
FAX: +(46) 8 775 56 00

Switzerland

Honeywell AG
Phone: +41 18552448
FAX: +(41) 1 855 24 45

Turkey

Honeywell Turkey A.S.
Phone: +90 216 578 71 00
FAX: +90 216 575 66 35

Ukraine

Honeywell
Tel: +380-44-201 44 74
Fax: +380-44-201-44-75

United Kingdom

Honeywell Control Systems Ltd.
Phone: +44 (0)1344 655251
FAX: +44 (0) 1344 655554

MIDDLE EAST

Abu Dhabi U A E
Middle East Headquarters
Honeywell Middle East Ltd.
Phone: +971 2 4041246
FAX: +971 2 4432536

Sultanate of Oman

Honeywell & Co Oman LLC
Phone: +968 24 701153/
Ext.33
FAX: +968 24 787351

Saudia Arabia

Honeywell Turki Arabia Ltd
Jubail Office
Phone: +966-3-341-0140
Fax: +966-3-341-0216
Honeywell - ATCO
Dammam Office
Phone: 0096638304584
Fax: 0096638338059

Kuwait

Honeywell Kuwait KSC
Phone: +965 242 1327 to 30
Fax: +965 242 8315
And
Phone: +965 326
2934/1821Fax: +965 326
1714

AFRICA

Mediterranean & African Distributors
Honeywell SpA
Phone: +39 (02) 250 10 604
FAX: +39 (02) 250 10 659

South Africa (Republic of) and sub saharan

Honeywell Southern Africa
Honeywell S.A. Pty. Ltd.
Phone: +27 11 6958000
FAX +27 118051504

NORTH AMERICA

Canada
Honeywell LTD
Phone: 1-800-737-3360
FAX: 1-800-565-4130

USA

Honeywell Process Solutions,
Phone: 1-800-423-9883 Or 1-800-343-0228
Email: ask-ssc@honeywell.com

LATIN AMERICA

Argentina
Honeywell S.A.I.C.
Phone: +(54-11) 4383-3637
FAX: +(54-11) 4325-6470

Brazil

Honeywell do Brasil & Cia
Phone: +(55-11) 7266-1900
FAX: +(55-11) 7266-1905

Chile

Honeywell Chile, S.A.
Phone: +(56-2) 233-0688
FAX: +(56-2) 231-6679

Mexico

Honeywell S.A. de C.V.
Phone: +(52) 55 5259-1966
FAX: +(52) 55 5570-2985

Puerto Rico

Honeywell Inc.
Phone: +(809) 792-7075
FAX: +(809) 792-0053

Trinidad

Honeywell Inc.
Phone: +(868) 624-3964
FAX: +(868) 624-3969

Venezuela

Honeywell CA
Phone: +(58-2) 238-0211
FAX: +(58-2) 238-3391

Honeywell

Honeywell Process Solutions

1860 West Rose Garden Lane
Phoenix, Arizona 85027

www.honeywell.com/ps

34-XY-25-16 Rev.8

November 2010

© 2010 Honeywell International Inc