

Wireless Differential Pressure Transmitter User Manual

900 MHz ISM Band



**XYR 5000 Line
34-XY-25-08
Rev. 5
08/06**

Wireless Differential Pressure Transmitter

Versions 1.70 or later



Important Information to the User



- Changes or modifications not expressly approved by the manufacturer may void the user's authority to operate the equipment.
- This device complies with Part 15 of the FCC Rules. Operation is subject to the following two conditions: 1) this device may not cause harmful interference, and 2) this device must accept any interference received, including interference that may cause undesired operation.
- This device is for mobile and fixed use only (not portable or body-worn). A separation distance of 20 cm must be maintained at all times between the antenna and the body of the user and bodies of nearby persons.
- If the Wireless Management Toolkit (RF Server) software is shutdown, the RS-485 network **MUST be physically disconnected** from the PC as the serial port is no longer being controlled by the software and may disrupt communications between the Base Radio(s) and Analog/Digital Output Module(s).
- This device has been designed to operate with an antenna having a maximum gain of 9 dBd. Antenna having a higher gain is strictly prohibited per regulations of Industry Canada. The required antenna impedance is 50 ohms.
- To reduce potential radio interference to other users, the antenna type and its gain should be so chosen that the equivalent isotropically radiated power (EIRP) is not more than that required for successful communication.
- The installer of this radio equipment must ensure that the antenna is located or pointed such that it does not emit RF field in excess of Health Canada limits for the general population; consult Safety Code 6, obtainable from Health Canada's website www.hc-sc.gc.ca/rpb.



FCC Certification



- This product is a frequency hopping RF transceiver module for the 900MHz ISM band, designed to meet FCC 15.247, and is used in industrial control and monitoring applications.
- The antenna is factory installed and **MUST NOT** be removed or modified by user.

Honeywell Inc.
Industrial Measurement and Control
2500 West Union Hills Drive
Phoenix, AZ 85027

Copyright 2006 by Honeywell International Inc.
Rev. 5-08/30/2006

While this information is presented in good faith and believed to be accurate, Honeywell disclaims the implied warranties of merchantability and fitness for a particular purpose and makes no express warranties except as may be stated in its written agreement with and for its customers.

In no event is Honeywell liable to anyone for any indirect, special or consequential damages. The information and specifications in this document are subject to change without notice.

Honeywell® and TotalPlant® are U.S. registered trademarks Of Honeywell International Inc.

Other brand or product names are trademarks of their respective owners.

About This Document

Revision Notes

The following list provides notes concerning all revisions of this document.

<u>Doc ID</u>	<u>Rel ID</u>	<u>Date</u>	<u>Notes</u>
34-XY-25-08	Rev. 3	03/05	Initial Release
34-XY-25-08	Rev. 4	12/05	Updated Control Drawings
34-XY-25-08	Rev. 5	08/06	Updated for version 1.70 software release.

Contacts

World Wide Web

The following lists Honeywell's World Wide Web sites that will be of interest to our industrial automation and control customers.

<u>Honeywell Organization</u>	<u>WWW Address (URL/e-mail)</u>
Corporate	http://www.honeywell.com
Industrial Measurement and Control	http://content.honeywell.com/imc/
International	http://www.honeywell.com/Business/global.asp
Field Instruments	http://www.honeywell.com/imc
Technical Assistance Center	ACE@Honeywell.com (e-mail)

Telephone

Contact us by telephone at the numbers listed below.

	Organization	Phone Number
United States and Canada	Honeywell Inc.	1-800-343-0228
	Industrial Automation and Control	1-800-525-7439
	Global Technical Support Center	1-800-423-9883
Asia Pacific	Honeywell Asia Pacific Inc. Hong Kong	(852) 8298298
Europe	Honeywell PACE Brussels, Belgium	[32-2] 728-2111
Latin America	Honeywell Inc. Sunrise, Florida U.S.A.	(305) 364-2355

Table of Contents

Section 1: Introduction	1
1.1: Using This Manual	1
1.2: About the Device	2
1.3: Unpacking	2
1.4: Software Compatibility	2
Section 2: Quick Start	3
Section 3: Installation	4
3.1: Mechanical Installation	4
3.2: Testing Communications	8
3.3: Commissioning	14
Section 4: General Configuration	15
4.1: Transmitter Displayed Messages	15
4.2: Overall Configuration Menu Map	16
4.3: Setting the Transmitter Tag Name	16
4.4: Setting a User Password	17
4.5: Resetting All Transmitter Settings	17
Section 5: Configuring the RF Communications	18
5.1: RF Channel Selection	18
5.2: RF Baud Rate Selection	19
5.3: RF Identification Selection	19
Section 6: Configuring the Sampling and Transmission Rates	21
6.1: Selecting the Normal Transmission Rate	21
6.2: Selecting the Normal Sampling Rate	22
6.3: Selecting the Abnormal Transmission Rate	23
6.4: Selecting the Abnormal Sampling Rate	24
6.5: Setting the Smart Rate Threshold	25
6.6: Selecting Rates, Thresholds, and Deadbands via the WMT	26
Section 7: Configuring the Process Variable	27
7.1: Zeroing the Sensor	27
7.2: Setting a Measurement Offset	28
7.3: Trimming the Measurement	28
7.4: Entering a 22-Point Curve	29
Section 8: Selecting and Configuring Operation Modes	30
8.1: Differential Pressure	30
8.2: Orifice Flow	31
8.3: Open Channel Flow	33
8.4: Level	35
Section 9: Maintaining the Transmitter	36
9.1: Changing the Battery	36
Section 10: Technical Specifications	37
Appendix A: Navigating User Menus	40
Appendix B: Displayed Message Definitions	41
Appendix C: Transmitter Menu Map	42
Appendix D: Modbus Register Definitions	43

Introduction

1.1: USING THIS MANUAL

This manual is designed to assist in installing, operating, and maintaining the following Differential Pressure Transmitters Models WD520, WD521, WD522, WD523, WD524 . The manual is broken into sections as follows:

Section 2: Quick Start

This section summarizes what must be done in order to get the device installed, configured and in operation quickly. However, it does not provide detailed or how-to information to perform the tasks outlined.

Section 3: Installation

This section covers general considerations regarding correctly commissioning the Transmitter as well as unique applications such as a flow service commissioning. Also covered in this section are mechanical installation considerations; such as Transmitter placement.

Section 4: General Configuration

In this section general configuration options such as password protection, and selecting a user password are discussed. Also covered is the setting of a Transmitter tag name, resetting of all Transmitter settings, and a discussion of the various messages that are displayed on the Transmitter LCD.

Section 5: Configuring the RF Communications

This section covers the setup of the Transmitter RF Communications which allow the Transmitter to achieve communication with the Base Radio. Parameters discussed are the Transmitter RF ID, the RF channel setting and Baud Rate.

Section 6: Configuring the Sampling and Transmission Rates

This section aids the user in selecting the amount of time between each sample of the process, and the time between each transmission of this sample to the Base Radio. Also discussed is the use of setting an abnormal threshold in which sampling and transmission times may change during a period when the process variable is within the abnormal region.

Section 7: Configuring the Process Variable

This section helps the user to zero the sensor, as well as discussing the setting of a measurement offset and trimming the process measurement.

Section 8: Selecting and Configuring Operation Modes

In this section the four operation modes (pressure, orifice flow, open channel flow, and level) of the Differential Pressure Transmitter are discussed in order to aid the user in selecting the right mode for his or her application and properly configuring the Transmitter for that specific application.

Section 9: Maintaining the Transmitter

This section explains how the Transmitter should be cared for once it has been placed into service and how to change the battery .

Section 10: Technical Specifications

This section explains the technical specifications that are associated with this device such as power characteristics, accuracy, and operating characteristics.

1.2: ABOUT THE DEVICE

The Honeywell Differential Pressure Transmitter is a reliable Radio Frequency (RF) transceiver coupled with a differential pressure sensor that can be used to monitor a variety of processes in hazardous and hard-to-reach areas. The time and expense of running wires often makes it difficult to measure parameters that have an economic impact on your plant operation, but the Differential Pressure Transmitter allows you to quickly and accurately monitor those devices at a fraction of the cost, which gives you bigger and faster returns on your instrumentation investments.

The Transmitters communicate in a secure, digital protocol over a band of frequencies from 902MHz to 928MHz. This data communication technique has been the backbone of the military's secure communications protocols for many years. These devices require no wires, permits or licenses, and they are easily set up and installed right out of the box.

You can use this device for long term monitoring in remote locations, for short-term data gathering on process conditions, or to quickly test the economic viability of a new installation.

The purpose of this manual is to help you install and maintain your Honeywell Differential Pressure Transmitter. BEFORE setting up and installing the Transmitter please setup and configure the Base Radio.

1.3: UNPACKING

Remove the Packing List and check off the actual equipment received. If you have any questions about your shipment, please call your Honeywell Representative. Upon receipt of the shipment, inspect the container for any signs of damage in transit. Especially take note of any evidence of rough handling. Report any apparent damage immediately to the shipping agent.

Please note that sometimes units are assembled with accessories when shipped. Inspect the shipment carefully if you think that something is missing. This is rare, as we take considerable care to pack units for shipment, but it does sometimes happen. Please give us a call and we may be able to resolve this matter quickly over the phone.

NOTE

The carrier will not honor any claims for damage unless all shipping materials are saved for their examination. If you find any damage while you are examining and removing the contents, save the packing material and the carton.

1.4: SOFTWARE COMPATIBILITY

Software for Honeywell is revised periodically. Internal device software may contain portions that are not compatible with previous versions of the Wireless Management Toolkit software.

To ensure software compatibility, Wireless Management Toolkit software version 1.70.138 or later must be used. If you believe you are experiencing software compatibility issues please call Honeywell Technical Support at 800-423-9883 or email ACE@Honeywell.com.

Quick Start

This section summarizes what must be done in order to get the device installed, configured, and in operation quickly. However, it does not provide detailed or how-to information to perform the tasks outlined.

1. Install the Transmitter in the desired location of operation.
2. Turn on the Transmitter by simultaneously pressing and holding the ENTER and NEXT buttons until the unit powers up.
3. Hit the NEXT button until the CONFIG message appears then hit ENTER.
4. Enter the default password 0000 to enter the CONFIG menu.
5. Enter the SET RF menu.
6. Set RF CHAN setting equal to the Base Radio's RF Channel.
7. Set BAUD RT setting equal to the Base Radio's Baud Rate.
8. Set RF ID number to be a unique value between 1 and 100.
9. Zero the sensor.
10. Trim and Offset the measurement (if appropriate).

Perform the following via the Wireless Management Toolkit software.

1. Select mode of operation.
2. Select appropriate engineering units.
3. Enter appropriate calculation parameters.
4. Select normal transmission rate.
5. Select normal sampling rate.
6. Select abnormal transmission rate.
7. Select abnormal sampling rate.
8. Set normal upper and lower values.



Warning



Warning! If the Transmitters have been running for an extended period of time with no signal from the Base Radio (the Base Radio is off or not present), the Transmitters will only search for the Base Radio every one hour or so. Turning the Transmitters off and back on will cause them to begin searching immediately.

If the "RF OFF" message is being displayed on the Transmitter LCD, perform the following:

- Set the RF CHAN setting equal to the Base Radio's RF Channel.

If a "NO RF" message is being displayed on the Transmitter LCD, check the following:

- Is the Transmitter set to the above listed configurations?
- Is the Base Radio on?
- Do the Transmitter and Base Radio settings match? (See Section 5 of the Transmitter and Base Radio User Manuals)
- Are the Base Radio and Transmitters unable to communicate due to obstructions or distance? (See Transmitter Manual: Transmitter Placement section).
- Have you run the RSSI Diagnostics? (See Section 3.2.1 Transmitter RSSI Diagnostic)

Installation

3.1: Mechanical Installation

In this section, mechanical installation instructions are discussed for the various setup capabilities of the Differential Pressure Transmitter. The subsections are as follows:

3.1.1: Transmitter Positioning

3.1.2: Installation in Liquid Flow Service

3.1.3: Installation in Gas Service

3.1.4: Installation in Steam Service

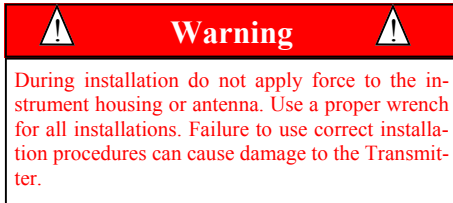

Each Honeywell Differential Pressure Transmitter is a rugged device which provides optimal performance when installed with careful consideration. It may be utilized in any ultrasound measurement service so long as care is exercised to prevent exposing the sensing elements to excess stress or temperature. Installation practices greatly affect the life that you can expect from your Honeywell Differential Pressure Transmitter.

Give careful consideration to the environment where you will be installing your instrument. Avoid installations that expose the device to excess temperature, high vibration, considerable shock, or exposure to dripping condensate or corrosive materials. Also avoid installing the device in an unserviceable location.

Most often these problems can be avoided with some thought at the time of installation. The practices noted below are generally recommended, but they can only act as a guideline and cannot cover all possible variations. The final installation must be made at your discretion and approval. You must be the judge of the actual installation.

Dimensioned mechanical drawings for aid in mechanical installation are located in Section 10: Technical Specifications

3.1.1: Transmitter Positioning

Correct positioning of the Transmitter will ensure the best performance of the device. When planning the positioning of the Transmitters there are a few parameters that must be paid attention to:

- The top of the Transmitter should point upwards. The bottom of the Transmitter should NOT point directly at the Base Radio and the Transmitter LCD should point away from the Base Radio.
- All Transmitters should maintain an approximate spacing of at least six feet apart from one another.
- The line of sight range between a Transmitter and Base Radio is 2000 feet at the 19.2K baud rate setting. Note that this range is reduced by the amount of RF noise present, obstructions, and the material properties of the obstruction.
- Only place the Transmitter in ambient operating temperatures of -40°F to 185°F (-40°C to 85°C).

Figure 3.1 gives examples of incorrect setups according to the previously mentioned parameters.

3.1.1: Continued

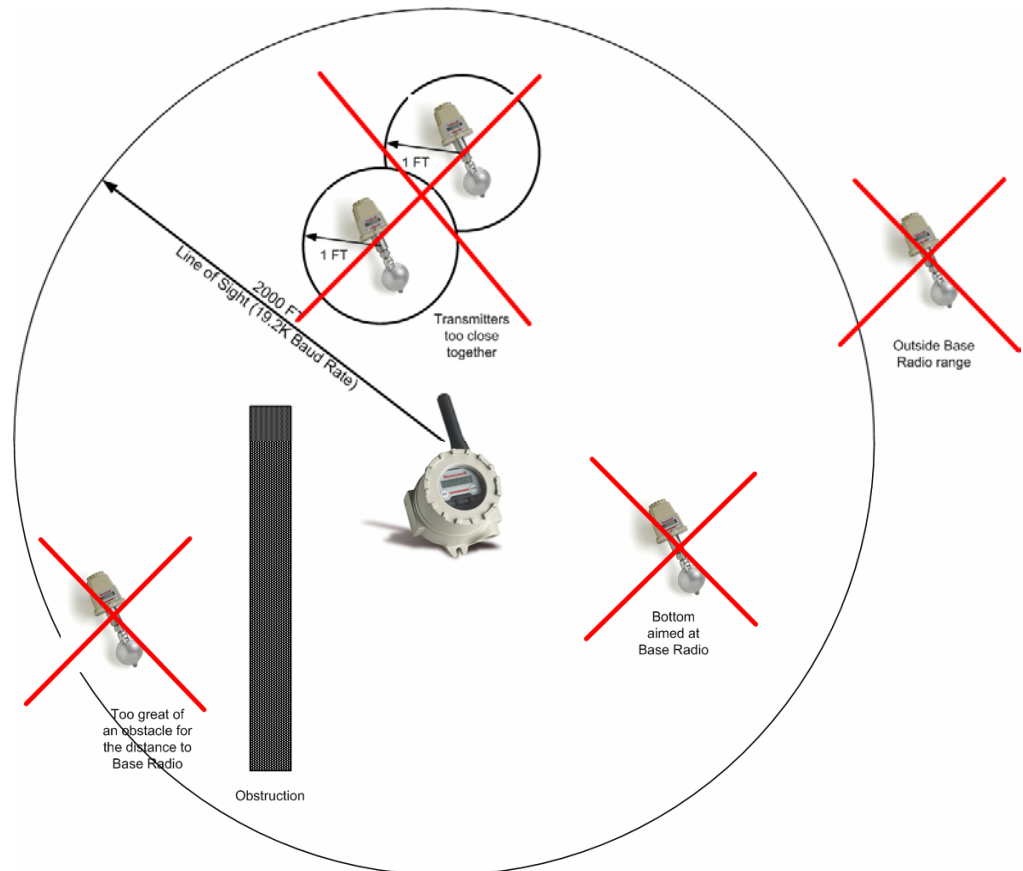

Figure 3.1: Examples of Incorrect Transmitter Positioning

Because there are so many setup possibilities we cannot cover them all. A correct setup would make sure that the above warnings are heeded, and that the Transmitter and Base Radio are capable of communication. The Testing Communications section will help you to determine if you have selected the correct installation points and orientations for your application.

3.1.1.1: Technique for Close Positioning of Transmitters

Transmitters may be placed closely together by carefully following this procedure. If this procedure is not followed, the communication range of the Transmitters will be significantly reduced and the Transmitters may eventually lose communication with the Base Radio entirely. This procedure is easy to implement, but please read carefully for a full understanding.

The Base Radio synchronizes with the Transmitters in Synch Groups of 7, organized by their RF ID numbers. If you want to place two Transmitters closer than 6 feet, make sure that you have set them in different groups. Note that this only applies to Transmitters that are communicating with the same Base Radio. The groups are defined in the following table:

Group	RF ID Range
1	1-7
2	8-14
3	15-21
4	22-28
5	29-35
6	36-42
7	43-49
8	50-56
9	57-63
10	64-70
11	71-77
12	78-84
13	85-91
14	92-98
15	99-100

For example, if two Transmitters are placed one foot apart and the first Transmitter has an RF ID number of 027, that means it is in the 4th group (22-28). The second Transmitter must have an RF ID number that is in another group (less than 22 or greater than 28). Setting the RF IDs of two closely spaced Transmitters so that the RF ID numbers are greater than 7 apart ensures that the Transmitters are in different Base Radio sync groups. This allows the closely spaced Transmitters to properly receive their synchronization signal from the Base Radio and maintain their proper communication and range.

You can also ensure that closely spaced Transmitters maintain their synchronization with their Base Radio by simply assigning each of the two closely spaced Transmitters to talk to a different Base Radio.

Either way, following this process will keep the Base Radio and Transmitters properly synchronized for long-term communication.

3.1.2: Installation in Liquid Flow Service

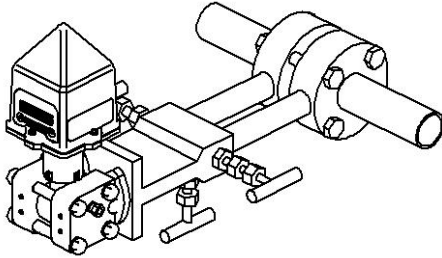

Figure 3.2: Installation in Liquid Flow Application

3.1.3: Installation in Gas Service

NOTE

The piping between the process and the transmitter must accurately convey the process pressure to the transmitter sensor. In transferring the pressure, there are several sources of error. These are: leaks, pressure loss due to friction (particularly if purging is used in the application), gas that is trapped in a liquid line, liquid that is trapped in a gas line, temperature induced density variations between the legs, other density variations between the measurement legs. The actual installation must be made to minimize these errors.

3.1.4: Installation in Steam Service

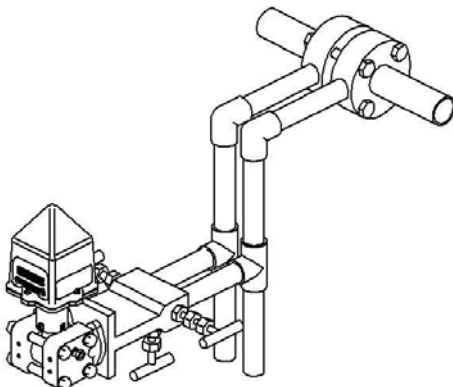

Figure 3.3: Installation in a Steam Application

In liquid service, you want all of the impulse lines to be completely full of liquid. It is generally best practice to place the process taps in the side of the liquid process line. This minimizes the entrance of gas bubbles, which tend to form at the top of the process line. It also tends to minimize the entrance of sludge and particulates that tend to accumulate in the bottom of the line.

1. Tap into the side of the process line.
2. Mount the transmitter beside or below the taps.
3. Position the vents level with or above the point where the impulse lines connect to the transmitter. This will give the best way to vent all of the air out of the impulse lines and flanges.

Here you want the impulse lines and manifold to be full of gas. Placing the taps in the top of the line generally prevents liquid from entering the transmitter. Mounting the transmitter above the process piping allows any liquid or condensate that does form in the impulse lines to drain back into the process piping.

1. Tap into the top of the line
2. Mount the transmitter above the taps

Steam service is slightly more complex. Here, you want to tap into the side of the steam lines to keep from collecting sludge and particulates. Process steam temperatures almost always exceed the working temperatures for the differential pressure transmitter. To surmount this problem, allow the impulse lines to condense and cool the steam by exposing the impulse lines to the general ambient temperature. Make the vertical section of the impulse lines long enough to make sure the steam condenses in the impulse lines. A good rule of thumb is that each foot of condensate line reduces the temperature by 20°F. Example: Saturated steam at 15 psig is approximately 250°F. To lower the temperature at the transmitter to 200°F, take 50°F divided by 20°F per foot = 2.5 feet of condensate piping. Drain valves on the vertical portion of the condensate lines are generally a good idea to help keep the system clean and free from a build-up of sludge.

1. Tap into the side of the steam line.
2. Run vertical impulse lines to allow the steam to condense and cool. Mount the transmitter below the line taps but above the drain valves.
3. Fill the impulse lines with water when commissioning the device.

3.2: Testing Communications

Remember, proper placement of the Transmitter will optimize your RF communication range and capabilities. Perhaps the best test to perform before mechanically mounting the unit is a quick hand-held test. There are two types of tests you can conduct: the RSSI (Received Signal Strength Indicator) Diagnostic and the Link Test. The RSSI Diagnostic measures the strength of the signal at the Transmitter. The Link Test measures the throughput of data sent to and from the Transmitter. The Link Test may be conducted from the Transmitter, Base Radio, or through WMT.

The RSSI Diagnostic should be conducted first to determine if the Base Radio is communicating with the Transmitter. Then the Link Test may be performed to test the validity of the installation.

To perform these tests you should have a good idea of where the Base Radio will be placed (for more information see Section 3 of the Base Radio User Manual). Place the Base Radio in the desired area and power on. Make sure that the Base Radio and Transmitter are on the same RF Channel and Baud Rate (See Section 5). You may also have to increment the number of Transmitters with which the Base Radio is communicating (See the Base Radio User Manual Section 4.3).

Once both the Base Radio and Transmitter are set up to be on the same network, make sure communication is established by looking at the Transmitter LCD for the 'RF OK' message in the Read-Only Sequence (see Section 4.1.1).

After communications have been established, go to Section 3.2.1 for the RSSI Diagnostic or Section 3.2.2 for the Link Test.

3.2.1: Transmitter RSSI Diagnostic

The Transmitter should be placed in RSSI Diagnostic mode to determine the signal strength at the location of the equipment to be monitored.

NOTE

The RSSI Diagnostic may only be conducted from Transmitters versions 1.56 and higher. The version number may only be checked when the Transmitter is powered up. See Figure 4.1.

The RSSI Diagnostic, located in the Transmitter's diagnostic menu, displays the RF signal strength in one of seven ranges. The signal strength is displayed on the LCD using a combination of '>' and '_' characters. Full signal strength is displayed as ">>>>>>>" while minimum signal strength is displayed as "> _ _ _ _ _". If the transmitter is not communicating with the Base Radio (i.e. NO RF), all underscore characters will be displayed (" _ _ _ _ _ _ _").

The RSSI is measured every time the Transmitter receives a message from the Base Radio. The signal strength of the received message from the Base Radio is calculated during this time. The actual signal strength in dBm for each range is shown below:

>	>	>	>	>	>	>
Less than	Between	Between	Between	Between	Between	Greater than
-105 dBm	-105 dBm & -100 dBm	-100 dBm & -95 dBm	-95 dBm & -90 dBm	-90 dBm & -85 dBm	-85 dBm & -80 dBm	-80 dBm

3.2.1 Continued

To place the Transmitter in RSSI Diagnostic mode follow the menu map shown in Figure 3.4. Note that the RSSI menu is under the DIAGNSE menu and not the CONFIG menu.

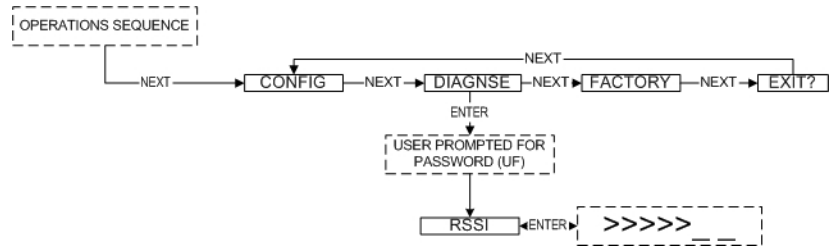

Figure 3.4: Menu Map to RSSI Mode

Now that the Transmitter is in the RSSI mode, bring the Transmitter close to the equipment you wish to monitor. Look at the LCD; notice the ‘>’ will constantly fluctuate. You should estimate an average value based on these fluctuations. The ideal signal integrity is seven arrows.

Once you have verified that you are receiving a signal, you should check to make sure the Transmitter is communicating properly with the Base Radio. To do so exit the RSSI by pressing ENTER, and then navigate to the EXIT? of the diagnostic menu and return to the Operations Sequence shown in Figure 4.1 in Section 4.1.

NOTE
 While using slower baud rate increases communication distance, it also increases the minimum transmit rate. See Section 5.2 for a list of the fastest transmit rates for each baud rate. This may not be suitable for your application.

If you see a NO RF message, then you do not have satisfactory RF communication with the Base Radio. If your application allows, move the Transmitter to a different position and check again for communications. If your application only allows you to mount at this particular point, you may want to try a slower baud rate setting for an increased range.

One final solution is to reposition the Base Radio. However, this may affect communications with previously installed Transmitters, and if so, may require the use of a second Base Radio for your application. To select a better spot for the Base Radio, see Section 3.1.1 of the Base Radio User Manual.

3.2.2 Link Test

The Link Test measures the wireless link performance of a Transmitter running in its normal operating mode. Messages are sent from the Transmitter to the Base Radio at a predefined interval called the Transmit Rate (see Section 6.1). Each message contains data for the previous time period (since the last transmit). The Link Test looks at the wireless performance going in both directions, from the Transmitter to the Base Radio and vice versa, and comes up with a rating. The result that appears on the display shows the determined link strength.

NOTE
 The Link Test may only be conducted from Transmitters, Base Radios and WMT versions 1.7 and higher. However, a Link Test being run from WMT version 1.7 may test communications with Transmitters older than version 1.7.
 The version number may only be checked when the Transmitter is powered up. See Figure 4.1.

In order to perform this test, the Transmitter must be communicating on the same channel and baud rate as the Base Radio. See Section 5 to configure communications.

The Link Test may be conducted from the Transmitter, Base Radio, or through WMT. Running the Link Test from WMT is ideal for testing communications for an installation with remote or hard-to-get-to Transmitters. To conduct the Link Test from a Base Radio, see Section 3.2.2.2. To conduct the Link Test from WMT, see Section 3.2.2.3.

3.2.2.1: Conducting a Link Test from the Transmitter

The Link Test is located in the Transmitter’s diagnostic menu (see Figure 3.5).

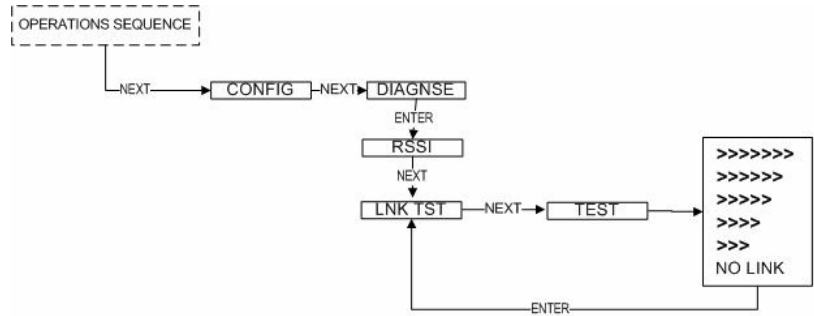

Figure 3.5: Menu Map to Transmitter Link Test

Using the NEXT and ENTER buttons, navigate to Link Test, and press the ENTER button to begin the test. The Transmitter will begin to test the link in both directions (to and from the Base Radio). During this time, the word TEST will appear on the LCD display. When the test is complete, the Transmitter will display the quality of the link. Be aware that the Transmitter uses the configured Baud Rate and transmission rate to perform this test. The length of time it will take to perform this test is dependent upon how fast the device is normally transmitting.

When enough messages have been observed, a link strength will be shown on the display. >>>>> indicates the strongest link, while > indicates the weakest link. The Link Test will continue to be evaluated and the rating on the screen may adjust itself. Keep in mind that the longer the Link Test runs the more data the Transmitter will have to evaluate.

The Transmitter installation site should strive to place the Transmitter in a location where it receives the highest number possible. A stronger link means less data re-transmits and better battery life.

3.2.2.2: Conducting a Link Test from the Base Radio

When the Link Test is conducted from a Base Radio, it measures the link strength between a selected Transmitter and the Base Radio. The Link Test data must be configured to match the communication parameters of the Transmitter from which you want to test. The Link Test is located in the Base Radio's diagnostic menu (see Figure 3.6).

To conduct a Link Test from the Base Radio, Navigate to Link Test, and press the Enter button. Next enter the RF ID for the Transmitter that you want to test. Then select the Normal Transmit rate that matches that of the Transmitter. If the Transmitter is transmitting at a different rate than the one you select in this menu, your results will be invalid.

Once the Normal Transmit Rate is selected, the Link Test will immediately start. The Base Radio will begin to test the link from the Transmitter. During this time, the word TEST will appear on the LCD display. When the test is complete, the Base Radio will display the quality of the link. Be aware that the length of time it takes to perform this test is dependent upon how fast the Transmitter is normally transmitting.

3.2.2.2 Continued

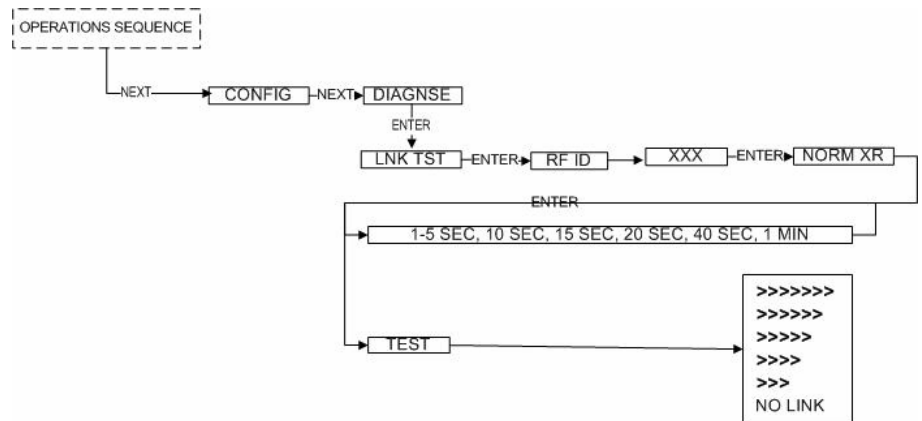

Figure 3.6: Menu Map to Base Radio Link Test

When enough messages have been observed, a link strength will be shown on the display. >>>>> indicates the strongest link, while > indicates the weakest link. The Link Test will continue to be evaluated and the rating on the screen may adjust itself. Keep in mind that the longer the Link Test runs the more data the Transmitter will have to evaluate.

The Transmitter installation site should strive to place the Transmitter in a location where it receives the highest number possible. A stronger link means less data re-transmits and better battery life.

3.2.2.3: Conducting a Link Test from WMT

To conduct a Link Test from WMT, make sure that WMT is running on the PC attached to the Base Radio. Then go to the Transmitter view, and right-click on the Transmitter you want to test Received data transmission from (Figure 3.7).

3.2.2.3 *Continued*

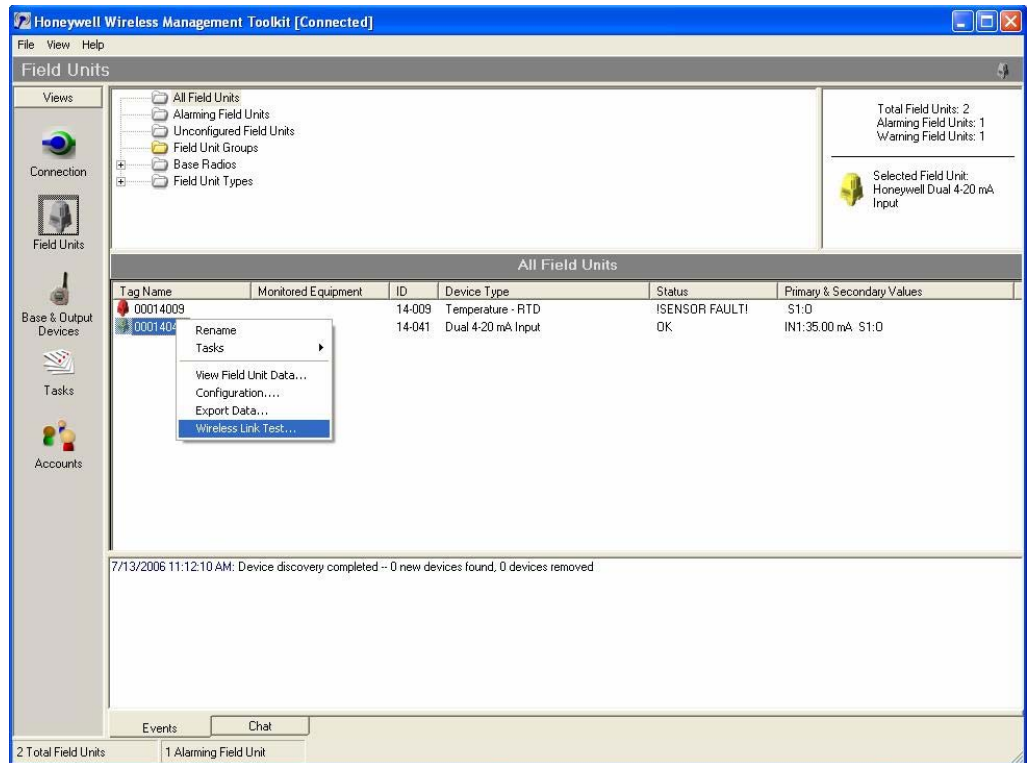

Figure 3.7: WMT Transmitter View

Select **Wireless Data Loss Test...** from the popup menu.

The Wireless Data Loss Test window appears, see Figure 3.8. The name of the Transmitter being tested appears in the title bar in parenthesis.

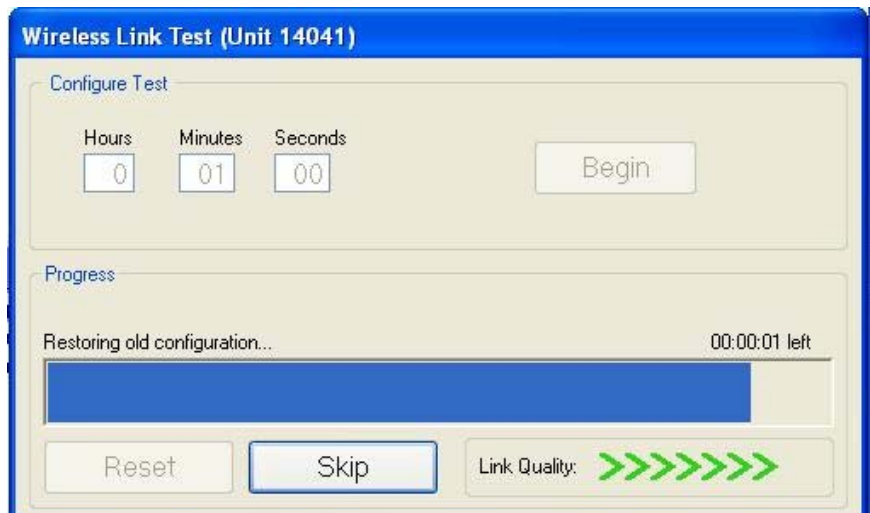

Figure 3.8: Wireless Data Loss Test

3.2.2.3 *Continued*

In the top of the window, you can configure the test to run for a specified amount of time. The longer the test, the more data the test will have to do an evaluation. Type the length of time that you want to run the test and click **Begin** to start. Once the test starts, WMT will reconfigure the Transmitter's Transmit Rate to the fastest possible for the selected Baud Rate. These rates are listed in Section 5.2. After the test has completed, it will restore the previously configured Transmit Rate.

During the test, the communications reliability is evaluated while the Transmitter is running under normal operating conditions. As the test runs, a link strength will be shown in the lower right hand corner of the window. >>>>> indicates the strongest link, while > indicates the weakest link. The Link Test will continue to be evaluated and the rating on the screen may adjust itself for the specified amount of time.

3.3: Commissioning

In this section commissioning instructions are discussed for the various setup capabilities of the Differential Pressure Transmitter. The subsections are as follows:

3.3.1: Liquid Service Commissioning Using a 3-Valve Manifold

3.3.2: Liquid Service Zeroing Using a 3-Valve Manifold

Be careful when commissioning your transmitter. Transient pressure shock waves that can overpressure the sensor causing zero shifts. These are most always generated on the upstream side of the instrument. By design, minimum zero shift is generated when the transmitter is over-pressured on the + side. Sensors are protected for overpressure on either side to the full pressure rating of the process flanges. However, stresses induced during overpressure will cause a temporary zero shift. It is therefore recommended that during commissioning and zeroing, every attempt should be made to prevent over-pressuring the sensor on either side. The procedures outlined below will allow commissioning and zeroing without over-pressurizing.

In the event that the sensor is subject to significant over-pressure, steps must be taken to re-establish the neutral instrument zero. If the sensor is or has been over-pressurized on the + side, any zero drift caused by the over-pressure will be negligible after a fairly short period of time -- about three hours. If the sensor has suspected to have been over-pressurized on the - side, over-pressure equal to the static line pressure of the process should be applied to the + side and the zero allowed to neutralize for several hours.

3.3.1: Liquid Service Commissioning Using a 3-Valve

1. Check overall installation to ascertain that all fittings, plugs, vents and bolts are secure, leak free and ready for service.
2. All manifold and line shutoff valves, if installed, should be in the closed position.
3. Open manifold bypass valve and both line shutoff valves if installed. This will put a zero differential pressure across the sensor.
4. Slowly crack open the + Upstream manifold block valve until the sensor is at line pressure. Then fully open this + Upstream manifold block valve.
5. Crack open the + and - side vent plugs until all air is purged out of the transmitter and the manifold. Close the vents tightly.
6. Check ZERO output and adjust if necessary.
7. Open the - Downstream manifold block valve fully.
8. Close the manifold bypass valve. The sensor is now in service.

3.3.1: Liquid Service Zeroing Using a 3-Valve Manifold

Differential Pressure Sensors in flow service need to be periodically re-zeroed. The procedure for re-zeroing assumes that the sensor in service and that the line shut-off valves are open, that the + and - manifold valves are open and that the manifold bypass valve is closed. To then re-zero the transmitter use the following procedure:

1. Open the manifold bypass valve fully.
2. Close the - Downstream manifold block valve.
3. Check the zero output and adjust if necessary. If you suspect gas or air in the impulse lines, these should be purged.
4. Open the - Downstream manifold block valve.
5. Close the manifold bypass valve. The sensor is now in service.

General Configuration

This section discusses the generalities for configuring the Transmitter via the NEXT and ENTER buttons. The subsections are as follows:

- 4.1: Transmitter Displayed Messages
 - 4.1.1: The Read-Only Sequence
- 4.2: The Overall Configuration Menu Map
- 4.3: Setting a Transmitter Tag Name
- 4.4: Setting a User Password
- 4.5: Resetting All Transmitter Settings

4.1: Transmitter Displayed Messages

To turn the Transmitter on, press and hold both the NEXT and ENTER buttons for a few seconds. Upon power up, the Transmitter will display the Power-Up Sequence, and then go into the Operations Sequence. These Sequences are shown in Figure 4.1 below:

NOTE

During configuration and testing, keep Transmitters at least six feet from the Base Radio and other Transmitters to ensure good communications.

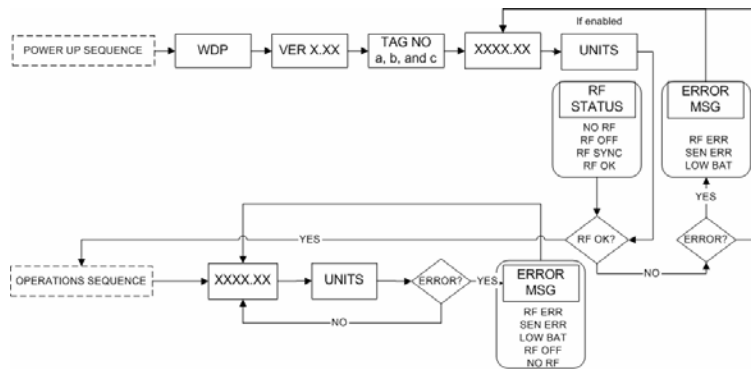

Figure 4.1: Transmitter Power-UP and Operations LCD Sequences

4.1.1: The Read-Only Sequence

Once the Transmitter is in the Operations Sequence, a user may access the READ-ONLY Sequence without a password by simply pressing the ENTER button at any time. The Read-Only Sequence, as shown in Figure 4.2, displays extra information about the current settings of the Transmitter that are not seen during the Operations Sequence, but does not allow any changes to be made to these settings.

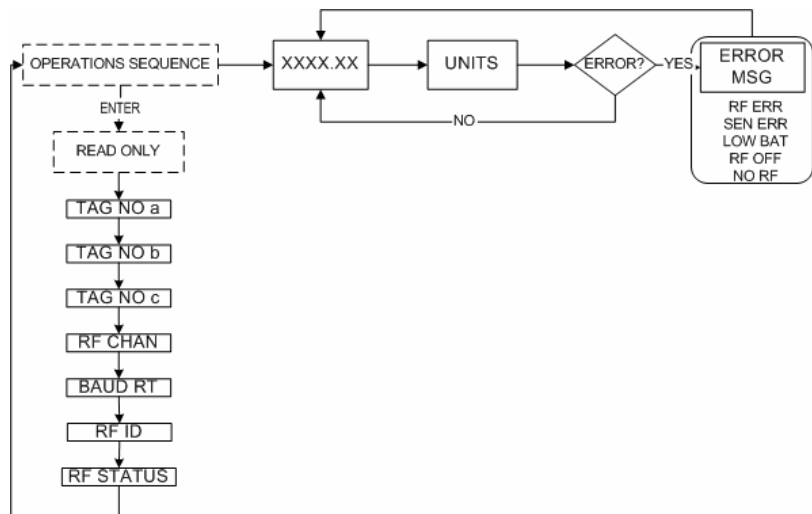
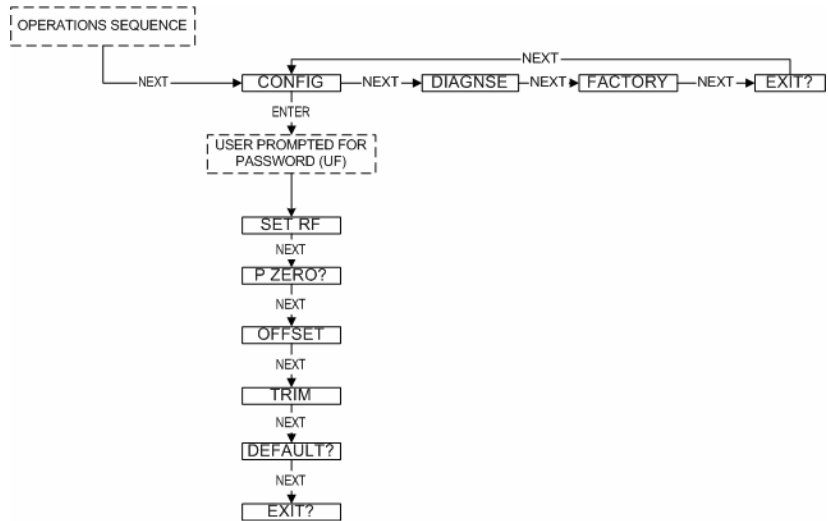

Figure 4.2: The Read-Only Sequence

4.2: Overall Configuration Menu Map

A complete Transmitter Menu Map is shown in Appendix C. Below is an overall view of the configuration menu to aid the user in setting up the Transmitter for proper operation.



NOTE
 The user must enter a four digit password to enter the CONFIG and DIAGNSE. The FACTORY menu is for factory use only. The default user password is 0000. For more information on the password see Section 4.4.

Figure 4.3: Overall Configuration Menu Map

4.3: Setting the Transmitter Tag Name

Each Transmitter has a user-settable Transmitter Tag Name. This Tag Name is displayed upon Transmitter power up, and when the Read-Only Sequence is selected. The Tag Name is a 21-character string that is displayed in three separate 7-character flashes on the Transmitter LCD.

The user may choose from A-Z, 0-9, a dash (“-“), and an underscore (“_”). The underscore has a special meaning to the software inside the Transmitter. For example, if you have a Tag Name that is only 5 characters long, then you do not want to wait for the rest of the 16 characters to be displayed on the LCD. So if your Tag Name was “TRAP1”, you would want to enter the Tag Name like this: “TRAP1 _____”.

The Tag Name is entered via the Wireless Management Toolkit. To do so, when the software is in the Transmitter view (See Section 8.1 of the Wireless Management Toolkit User Manual), right-click the Transmitter icon, select **Rename**, then enter the Tag Name you wish the Transmitter to have.

This Tag Name will then be uploaded to the Transmitter and can be displayed by pressing the ENTER button when the unit is in the Operations Sequence (See Section 4.1.1 of this manual).

4.4: Setting a User Password

The screenshot shows a software window titled "Differential Pressure Properties - 00009044 (9-44)". It has several tabs: "General", "Range", "Operation Mode", and "Sensor Offset". The "General" tab is active. Under "Description", there are fields for "Location:", "Date Installed:", and "Comments:". Below that, under "General", there are fields for "Monitored Equipment:" and "Field Unit Password:" which contains the value "0000". At the bottom, there is a note: "NOTE: Device is in Pressure mode and units are in Psi." and buttons for "Load from File...", "Save to File...", "OK", and "Cancel".

Figure 4.4: Setting a User Password

4.5: Resetting All Transmitter Settings

NOTE

Resetting the Transmitter by using the DEFAULT menu option will not reset the TRIM or OFFSET values.

Each Transmitter has a password that will lock out undesired users from making changes to the Transmitter. Any user may still view some of the Transmitter settings by pressing the ENTER key during the Operations Sequence and viewing the Read-Only Sequence.

The password is a four-digit password. The factory default is 0000. If you wish to select a different password, one may be entered via the Wireless Management Toolkit software. To do so, enter the configuration menu (See Section 9.2 of the Wireless Management Toolkit User Manual). Once in the configuration menu, click on the **General** tab to display the general information as shown in Figure 4.4.

The Transmitter password for this device can be set by entering a four-digit number in the **Transmitter Password** field. Once a password has been entered, click **OK** to save and download the password to the Transmitter.

Please note that the password only protects the Transmitter from unauthorized configuration via the NEXT and ENTER buttons. The Wireless Management Toolkit requires a user login password to gain access to all configuration parameters. However, user accounts are available and can be set with different access levels and restrictions (For more information on user accounts see the Wireless Management Toolkit User Manual Section 8.4).

To reset all Transmitter settings to their default state, the user must navigate to the DEFAULT menu option in the CONFIG menu via the keypad.

Once at the default menu option, pressing the ENTER button will display 'RESET?' on the LCD; which asks if you are sure you want to reset the device to its default configuration. You will then be prompted with 'NO' on the LCD. Pressing the ENTER button while 'NO' is being displayed will NOT reset the device. Pressing the NEXT button will display 'YES' on the LCD. If you press the ENTER button while 'YES' is being displayed the device will be reset.

Configuring the RF Communications

In order for the Transmitter and the Base Radio to communicate, they must be on the same RF Channel and must be transmitting at the same Baud Rate. While all Transmitters and Base Radios are set to default configurations at the factory, if any configuration differences are present, the Base Radio will not be able to communicate with the Transmitters. The subsections are as follows:

- 5.1: RF Channel Selection
- 5.2: RF Baud Rate Selection
- 5.3: RF Identification Selection

5.1: RF Channel Selection

Warning

During installation do not apply force to the instrument housing or antenna. Use a proper wrench for all installations. Failure to use correct installation procedures can cause damage to the Transmitter.

The RF Channel defines a set of frequencies on which communication takes place between the Base Radio and the Transmitter. Each RF Channel has a different set of frequencies, thus allowing the user to have multiple different wireless networks co-existing throughout the same facility.

All Base Radios and Transmitters can be set to one of 16 different RF channels. The only Transmitters recognized by a particular Base Radio are the units that are on the same RF Channel as that Base Radio. This allows the user to decide which Transmitters communicate with each Base Radio.

The RF Channel can be thought of as a set of walkie-talkies. If both walkie-talkies are on channel one they can communicate. If a walkie-talkie is on channel one and the other is on channel two, they cannot communicate. Likewise, if two walkie-talkies are on channel one and two other walkie-talkies are on channel two, the walkie-talkies on channel one cannot hear what is being transmitted by the walkie-talkies on channel two.

Each Transmitter comes from the factory with the RF Channel set to OFF. This means the Transmitter will not communicate to any Base Radio. To set the Transmitter for communication, first determine the channel that you want to use. Then follow the Transmitter menu map shown in Figure 5-1 to configure the RF Channel.



Figure 5.1: Menu Map to RF Channel Setting

Once in the RF Channel menu, increment it by pressing the NEXT button. When selecting this value, do not choose an RF Channel that is currently being used by other Honeywell Wireless Systems as this can cause communication problems.

5.2: Baud Rate Selection

The RF Baud Rate refers to the speed at which the Base Radio and Transmitters communicate. The RF baud rate for the Base Radio and the Transmitter must be the same in order for successful communication to occur. There are three selectable settings with the fastest update times and ranges listed below:

- 4.8K– Rate of 4.8 Kbaud (Update every 20 seconds)
- Range of 3000ft (Line of Sight)
- 19.2K– Rate of 19.2 Kbaud (Update every 5 seconds)
- Range of 2000ft to 2500ft (Line of Sight)
- 76.8K– Rate of 76.8 Kbaud (Update every 1 second)
- Range of 500ft to 750ft (Line of Sight)

NOTE

If you change the baud rate of a Transmitter, you must also change the baud rate of the Base Radio and all other Transmitters that are communicating with that Base Radio.

A faster RF Baud Rate allows the user to transmit more information in a given period of time, but it will also limit the Transmitter’s range. If you need more distance out of your Transmitters or are encountering difficulties by frequently losing communications, then select a slower baud rate.

Follow the Base Radio menu map shown in Figure 5.2 to configure the RF Baud Rate. The factory default is the 19.2K Baud Rate.

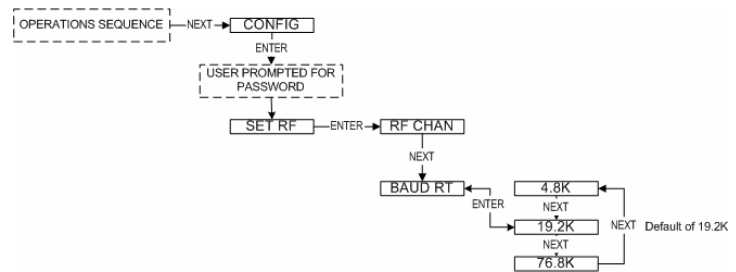

Figure 5.2: Menu Map to Baud Rate Setting

5.3: RF Identification (RF ID) Selection

Each Transmitter is identified by the Base Radio and WMT according to the RF ID given to that particular unit. Two Transmitters CANNOT have the same RF ID and be on the same RF Channel (if you do not know the RF Channel see section 5.1). If the Transmitter is in the Operations Sequence, pressing the ENTER button displays the Read-Only Sequence on the LCD. The RF ID of that unit will be displayed in this format: ID 3.

All Transmitters in your system are set to a default RF ID number upon shipment. For example, if you have ordered a Base Radio and three Transmitters, the Transmitters will be configured to RF ID’s 0, 0 and 0. You must set these units to three different IDs between 1 and 100. The Transmitters in this example could be set to RF IDs 1, 2 and 3.

First determine the RF ID’s you’d like to give each unit. Then follow the menu map shown in Figure 5.3 to configure the RF ID. The factory default is RF ID 0, which disables the RF communication of the unit.

5.3: Continued

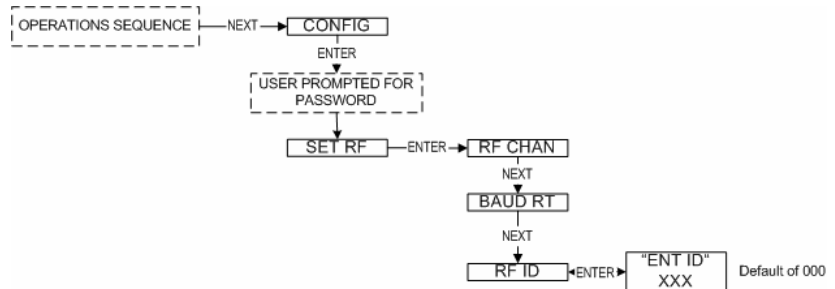

Figure 5.3: Menu Map to RF ID Setting

Once you have selected the RF ID you wish to use for this particular Transmitter, exit the menus and return to the Operations Sequence.

The Transmitter should now be successfully configured to the Base Radio. To check this, press ENTER while the Transmitter is in the Operations Sequence for the Read-Only Sequence to be displayed. You may see an RF SYNC message displayed on the Transmitter LCD. This means that the Transmitter and Base Radio are attempting to synchronize communications. If this is successful the RF Status will display an RF OK message. If this is unsuccessful the RF Status will display a NO RF message.

Also notice the two small arrows on either side of the LCD; if they are fluctuating up and down, that indicates the Transmitter and Base Radio are successfully communicating. If only one or none of the arrows are moving then RF communication is unsuccessful.

Configuring the Sampling and Transmission Rates

The Differential Pressure Transmitter is very versatile with many programmable features and can be used in numerous different applications. Because no two applications are the same, some configuration is required for each unit. This section will walk you through the initial configuration of these sample and transmit settings. The subsections are as follows:

- 6.1: Selecting the Normal Transmission Rate
- 6.2: Selecting the Normal Sampling Rate
- 6.3: Selecting the Abnormal Transmission Rate
- 6.4: Selecting the Abnormal Sampling Rate
- 6.5: Setting the Smart Rate Threshold
- 6.6: Selecting Rates, Thresholds, and Deadbands via the Software

6.1: Selecting the Normal Transmission Rate

The Normal Transmission Rate is the interval in which the Transmitter transmits data to the Base Radio. The Transmitter is in a “sleep” mode to save power during the operations sequence. This mode turns off most of the electronics on the unit, with the exception of the LCD, in order to preserve battery life. The Transmitter will then ‘wake up’ every Normal Sampling Period and take the necessary process value readings. The Transmitter will then transmit these readings to the Base Radio on an interval determined by the Normal Transmission Rate.

Notice that the fastest update rate of the Normal Transmission Rate is dependent on the baud rate setting you selected earlier (see Section 5.2). The transmission rates cannot update data faster than their communication speed allows. Thus, if you selected the 19.2K Baud Rate setting, your fastest transmission rate will be 5 seconds. The Transmitter automatically determines these settings and adjusts the menu options accordingly. A complete table of these parameters is shown in Section 6.2.

In order to properly set the Normal Transmission Rate, you must first determine how often you need updates from the Transmitter. You have a selectable range of 1-5, 10, 15, 20, 40 seconds and 1 minute. The factory default is 10 seconds.

If all of the data does not get through, the data is resent the following second. This prevents data from being lost. However, if the Transmission Rate is set to the maximum (1 second; 76.8K baud), then the data cannot be resent the following second because the next set of data must be sent in order to meet the Transmission Rate.

The Wireless Management Toolkit software must be used to configure this setting. An explanation of how to select the Normal Transmission Rate using the Wireless Management Toolkit software can be found in Section 6.6 of this manual.

6.2: Selecting the Normal Sampling Rate

The Normal Sampling Rate is the interval in which the Transmitter reads the monitored process value. As previously mentioned, the Transmitter is in “sleep” mode to save power during the operations sequence. This mode turns off most of the electronics on the unit (with the exception of the LCD) in order to preserve battery life. The Transmitter will then ‘wake up’ for every Normal Sampling Period and take the necessary process value readings.

Notice that the minimum speed of the Normal Sampling Rate is dependent on the Normal Transmission Rate setting selected (see Section 6.1). The Sampling Rate cannot be set slower than the Normal Sampling Rate. Thus, if you selected the Normal Transmit Rate setting to be 10 Seconds the Normal Sampling Rate must be set to 10 Seconds or faster. A complete table of these parameters is shown below.

Baud Rate (communication range) (speed of updates)	76.8K	19.2K	4.8K
	500-750 feet	2000-2500 feet	3000 feet
	1 Second	5 Seconds	20 Seconds
Normal and Abnormal Transmit Rates	1 Second or Greater	5 Seconds or Greater	20 Seconds or Greater
Normal and Abnormal Sampling Rates	Equal to Transmit Rate or Less	Equal to Transmit Rate or Less	Equal to Transmit Rate or Less

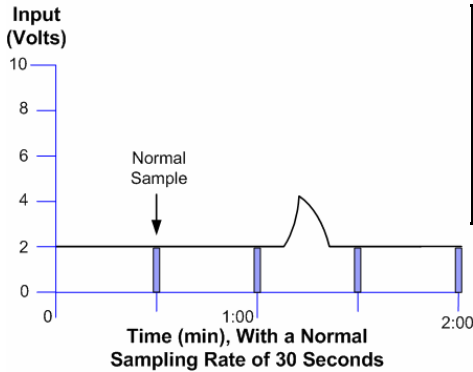

Figure 6.1: Incorrect Sampling Rate

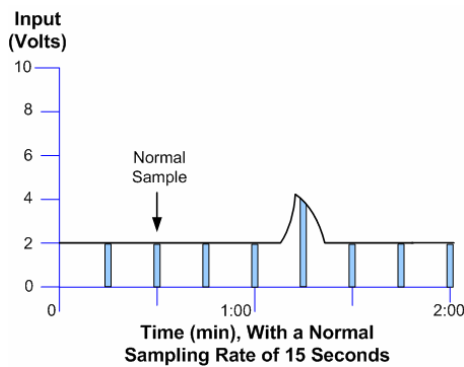

Figure 6.2: Correct Sampling Rate

In order to properly set the Normal Sampling Rate determine how often updates are needed from the Transmitter when the process being monitored is operating under normal conditions. The Transmitter has a selectable range of 1-5, 10, 15, 20, 30, and 60 seconds depending on the Normal Transmission Rate. The factory default is 1 second. However, the more frequently the Transmitter wakes up to check the monitored device, the faster you will use up the battery life of the Transmitter.

Figure 6.1 is an example of what happens when the Normal Sampling Rate is too slow for the process being monitored. Notice how the rise in the voltage level falls between two normal samples, and thus goes completely undetected.

Figure 6.2 is an example of what happens when the Normal Sampling Rate is correctly set for the device that is being monitored. Notice how this setting makes it possible to sample the rise in the voltage level.

The Wireless Management Toolkit software must be used to configure this setting. An explanation of how to select the Normal Sampling Rate using the Wireless Management Toolkit software can be found in section 6.6 of this manual.

6.3: Selecting the Abnormal Transmission Rate

NOTE
 If the device is not configured to check for abnormal process conditions using Sample Bands (section 6.6), the Abnormal Transmission rate is not used and this section can be ignored.

The Abnormal Transmission Rate is identical to the Normal Transmission Rate with one exception. The Abnormal Transmission Rate only applies while the Transmitter is in an abnormal condition (see Section 6.6). This allows an increase or decrease in the frequency of information you receive depending on the operating conditions of the process being monitored.

In order to properly set the Abnormal Transmission Rate, determine how often updates are needed from the Transmitter when the process being monitored is operating under normal conditions. The Transmitter has a selectable range of 1-5, 10, 15, 20, 40 seconds and 1 minute. Figure 6.3 is an example of how the device switches transmission rates from Normal Transmission Rate to Abnormal Transmission Rate. Note how the first abnormal transmission is sent immediately when the Normal Upper Value set point is exceeded. The next transmission will then follow this immediate transmission by 10 seconds (or whatever the Abnormal Transmission Rate is set to). The transmissions will continue at this interval until the process value drops below the Normal Upper Value set point.

Once the process value drops below this set point, another transmission is sent to the Base Radio. The transmissions will then be sent at the Normal Transmission Rate of one minute (the current setting for the Normal Transmission Rate) from the time of the last abnormal transmission.

The user should also note that the transmission time depends on the sampling rate, and when the process value is sampled. If the Normal Sampling Rate is 30 seconds, then the process value may be above the Normal Upper Value for up to 29 seconds before an abnormal condition is detected. This means that the transmission could be as late as 29 seconds after the process value exceeded the Normal Upper Value.

The Wireless Management Toolkit software must be used to configure this setting. An explanation of how to select the Abnormal Transmission Rate using the Wireless Management Toolkit software can be found in section 6.6 of this manual.

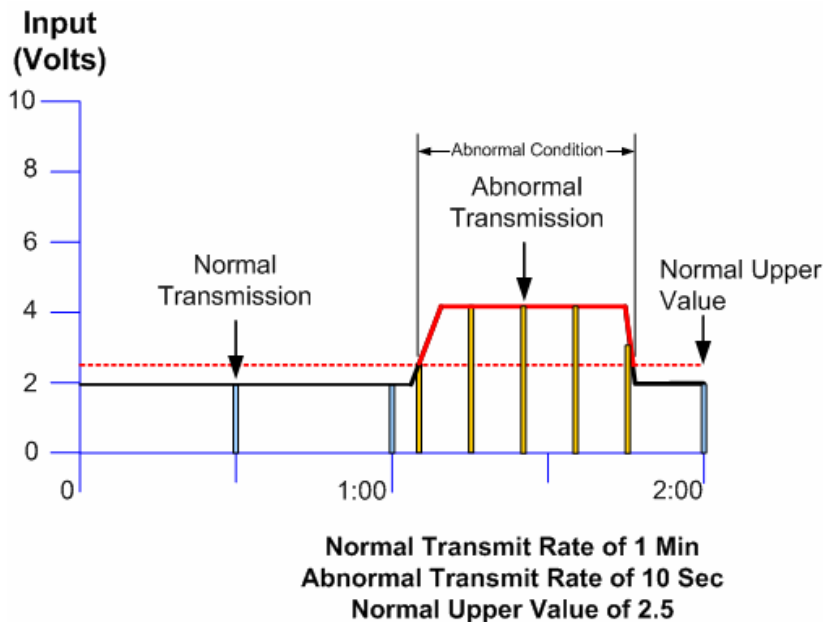

Figure 6.3: Example of Abnormal Transmission Rate Setting

6.4: Selecting the Abnormal Sampling Rate

NOTE

If you do not need more or less frequent samples and updates from a Transmitter for a given application, then there is no need to complete this section. Simply set the Normal Transmission and Sampling Rates to the desired speeds, and make sure that the Normal Upper and Lower Values are configured to **Disabled**.

The Abnormal Sampling Rate is identical to the Normal Sampling Rate with one exception. The Abnormal Sampling Rate only applies while the Transmitter is in an abnormal condition (see 6.6 Selecting the Normal Upper and Lower Values). This allows an increase or decrease of the frequency of information you receive depending on the operating conditions of the process being monitored.

In order to properly set the Abnormal Sampling Rate, determine how often updates are needed from the Transmitter when the process being monitored is operating under normal conditions. The Transmitter has a selectable range of 1-5, 10, 15, 20, 40 seconds and 1 minute. Figure 6.4 is an example of how the device switches sampling methods from Normal Sampling Rates to Abnormal Sampling Rates. Note how the first abnormal sample is taken a few seconds after the Normal Upper Value set point is exceeded. The next sample will then follow this sample by 5 seconds (or whatever the Abnormal Sampling Rate is set to). These samples will continue at this interval until the process value drops below the Normal Upper Value set point.

Once the process value drops below this set point the sampling rate will return to the Normal Sampling Rate. Also, the Abnormal Sampling must be equal to or faster than the Abnormal Transmission Rate.

The user should also note that the transmission time depends on the sample rate, and when the process variable is sampled. If the Normal Sampling Rate is 30 seconds, then the process variable may be above the Normal Upper Value for up to 29 seconds before abnormal condition is detected. This means that the transmission could be as late as 29 seconds after the process variable exceeded the Normal Upper Value.

The Wireless Management Toolkit software must be used to configure this setting. An explanation of how to select the Abnormal Sampling Rate using the Wireless Management Toolkit software can be found in section 6.6 of this manual.

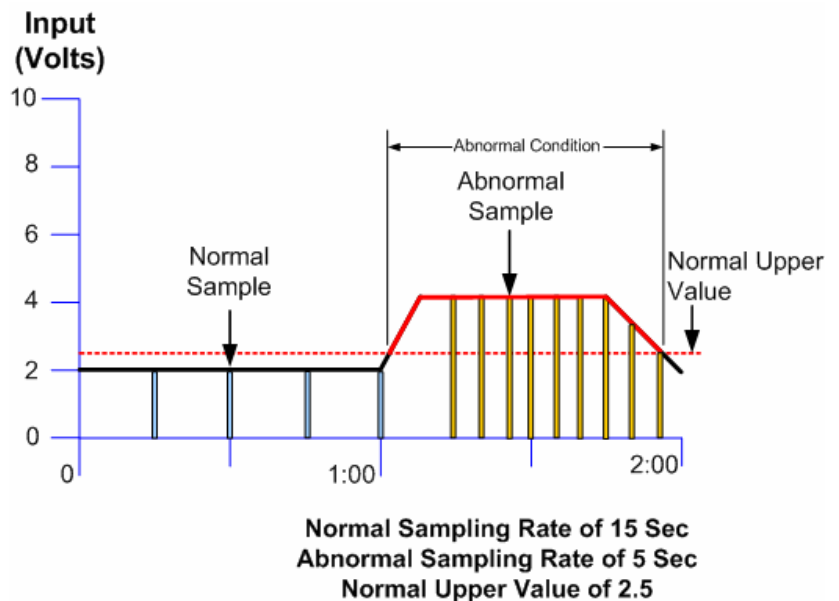

Figure 6.4: Example of Abnormal Sampling Rate Setting

6.5: Setting the Smart Rate Threshold

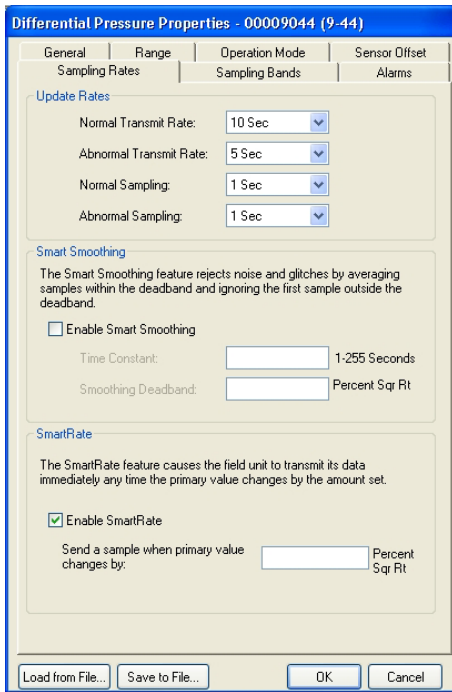

Figure 6.5: Smart Rate Configuration Using WMT

The Smart Rate is a feature used to trigger radio transmission of the measured data sooner than the normal or abnormal rate specified by the user. This feature is used to construct a more accurate graph of the measured process value vs. time than is possible with the fixed transmission rates, while using less battery power.

First you must decide the amount that the process variable must change since the last data sample to trigger a new transmission of the process value.

If the process value changes by more than the entered Smart Rate amount within the normal or abnormal sampling rate (whichever is active), then the process variable is transmitted immediately. The normal/abnormal transmit clock is then reset upon this transmission. If no Smart Rate amount exceeding change takes place in the next normal/abnormal sample, then the next transmission will be the normal/abnormal transmit rate period.

The amount entered is in the same units as were selected by the user to be displayed on the Transmitter. If the measured process value does not change by more than the entered Smart Rate amount within the time between the sampling rates (whichever is active), then the process value is transmitted on the next transmit rate.

If changes in the process value, which exceed the Smart Rate Amount, continue to occur, the process value is transmitted repeatedly.

To configure the Smart Rate using the Wireless Management Toolkit software, enter the configuration menu (See Section 9.2 of the Wireless Management Toolkit User Manual). Once in the configuration menu click on the **Sampling Rates** tab to bring up the sampling rate information as shown in Figure 6.5.

To enable the Smart Rate, click the check box labeled **Enable SmartRate**. The user will then be allowed to enter a “delta”, or amount changed, value which will trigger a transmission.

Once a value has been entered, click **OK** to save and download the configuration changes to the Transmitter.

6.6: Selecting Rates, Thresholds, and Deadbands via the WMT

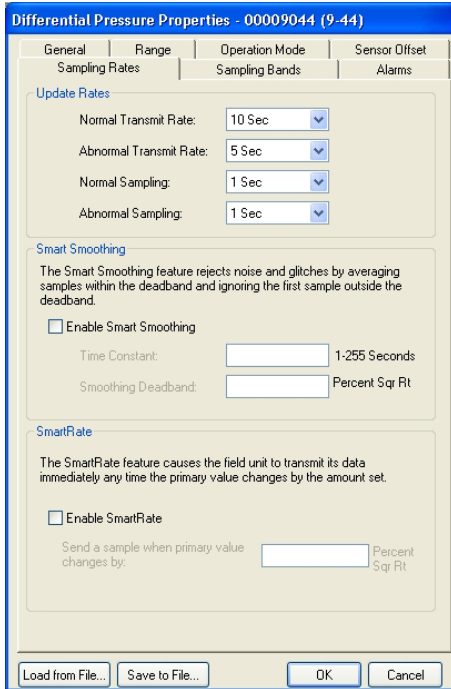

Figure 6.6: Sample and Transmission Rate Selection Using WMT

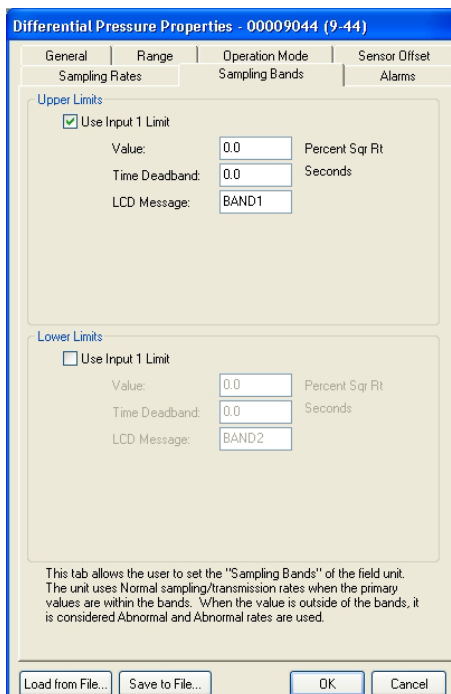

Figure 6.7: Normal Upper and Lower Value Selection Using WMT

To configure the Normal and Abnormal Sampling and Transmission menu options using the Wireless Management Toolkit software, enter the configuration menu (See Section 9.2 of the Wireless Management Toolkit User Manual). Once in the configuration menu click on the **Sampling Rates** tab to bring up the sampling rate information, as shown in Figure 6.6.

To select the Normal Transmission Rate, select one of the time periods from the drop box. Next, select an Abnormal Transmission Rate in the same manner. Note that the Normal and Abnormal Transmission Rate can be the same.

Once the transmission rates have been selected, the user should select the desired sampling rates. Note that the sampling rate must be equal to or faster than the associated transmit rate. For example, in Figure 6.6 the Normal Transmission Rate is set to 10 seconds and the Normal Sampling Rate is set to 1 second. This is a valid configuration.

If the user incorrectly enters the Transmission and Sampling Rates, a message will be displayed explaining this to the user. The user will not be allowed to leave this screen before the setting is corrected.

To configure the Normal Upper and Lower Value menu options using the Wireless Management Toolkit software, enter the configuration menu (See Section 9.2 of the Wireless Management Toolkit User Manual). Once in the configuration menu click on the **Sampling Bands** tab to bring up the sampling band information as shown in Figure 6.7.

To set a limit to the normal condition, enable the limit by clicking on the **Use Input 1 Limit** check box. Then enter the value and time deadband for the limit.

Configuring the Process Variable

This section helps the user in the selection of engineering units, as well as discussing the setting of a measurement offset and trimming the process measurement. The subsections are as follows:

- 7.1: Zeroing the Sensor
- 7.2: Setting a Measurement Offset
- 7.3: Trimming the Measurement
- 7.4 Entering a 22-Point Curve

7.1: Zeroing the Sensor

Zeroing the sensor can only be performed from the Transmitter. You will need to check the “position zero” reading on the transmitter. The Differential Pressure Transmitter is a sensitive device. Its elevation and its orientation in the field may be different from the orientation in the factory where it received its last configuration. To compensate for position changes, you may need to perform a sensor position adjustment once the unit is installed.

For this step, power the unit and apply zero pressure. Be sure that the unit is installed in its final location or that it is oriented exactly as it will be in its final installation. If you have a differential pressure device, you will also need to go through a series of operations to fill the impulse lines to the device (See Section 3.2: Commissioning).

If you have a transmitter pressure reading of “zero”, (that is, the transmitter reading is within the specified accuracy of $\pm 0.07\%$ of the full scale value when zero pressure is applied), there is no need to zero the sensor. If your “zero” reading is outside of this value, you will need to execute the position zero adjustment by following the menu map shown in Figure 7.1.

When P ZERO is selected, the sensor is zeroed. However, the displayed value is calculated relative to the offset point. The unit will display an amount equal to the keypad-configured offset added to the WMT-configured level offset, if applicable. If the intent is to have the unit display “0,” the offsets must be zero before applying P ZERO.

For example, if 3 PSI of pressure is applied to a sensor, an offset of 5 PSI is entered into the keypad, and P ZERO is applied, the unit will display 5 PSI. If the pressure is then raised by 1 PSI to 4 PSI, the unit will display 6 PSI.

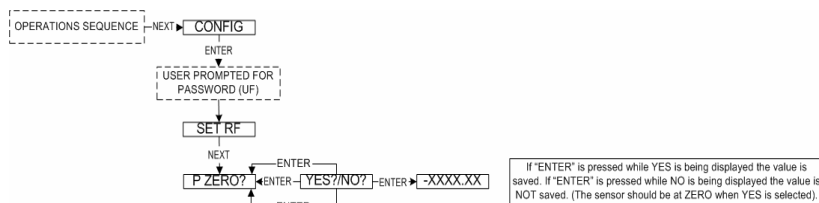

Figure 7.1: Menu Map to Pressure Zero Setting

7.2: Setting a Measurement Offset

For various applications, the user may wish to display an offset value rather than the actual value. To enter an offset, navigate to the OFFSET command, as shown in Figure 7.2. Then enter the offset to be added or subtracted from the actual measured value.

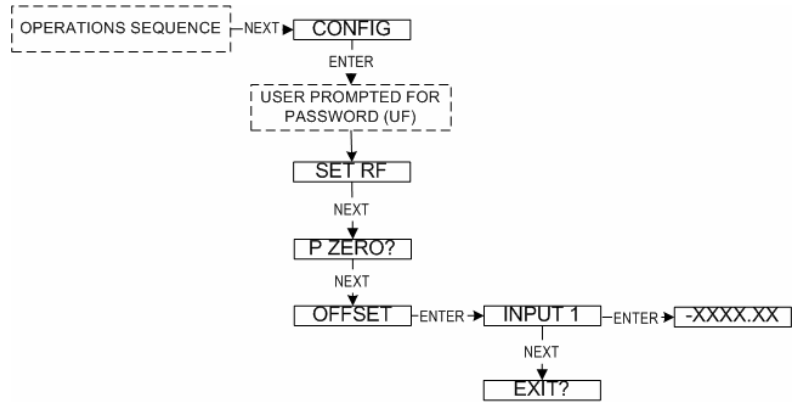

Figure 7.2: Menu Map to Offset Setting

7.3: Trimming the Measurement

The Transmitter interface allows you to set a two-point correction curve for the sensor. This process is often called “trimming” because the displayed value is trimmed up or down to reflect the actual value being applied.

To set a trim point, take the Transmitter offline and navigate to the TRIM menu, as shown in Figure 7.3, and select the input to be trimmed. Then select the point you wish to enter. After selecting the point, you will have the option to trim the device or reset the trim. If NEW TRIM is selected, you will be prompted to enter the lower point first. Type the value and press ENTER. The Transmitter will prompt you to apply the indicated process value to the Transmitter. Apply the process value and press ENTER. Repeat the process for the higher point. After both points have been trimmed, you can choose to save or discard the new trim.

NOTE

If entering a two-point trim via the NEXT and ENTER buttons, Point 2 **MUST** be greater than Point 1 in order for the trim to work properly.

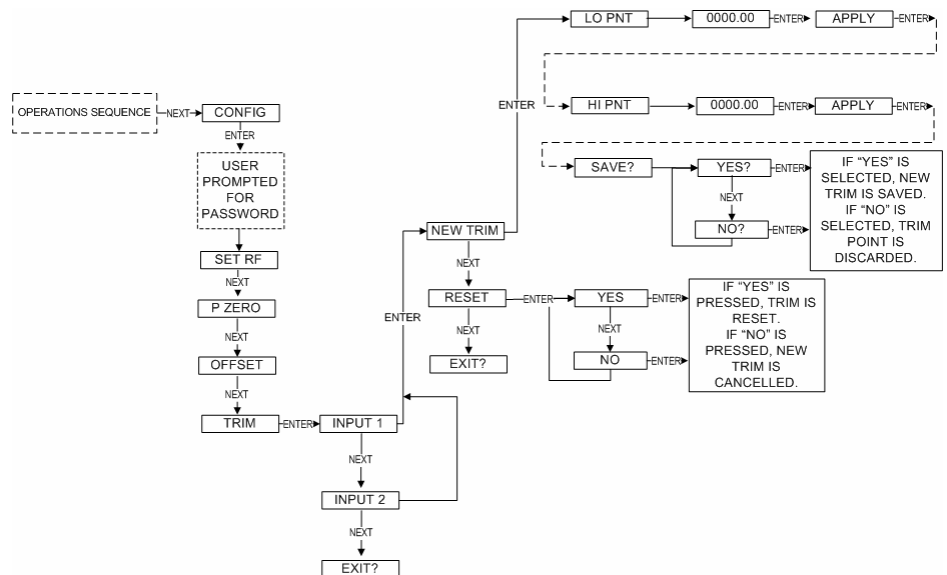

Figure 7.3 Menu Map to Trim Setting

7.4: Entering a 22-Point Curve

If you are running WMT, a 22-point sensor offset curve may be entered for the Transmitter. To do so, open the configuration dialog box. Once in the configuration dialog box, click the Sensor Offset tab to bring up the offset information as shown for Level in Figure 7.4.

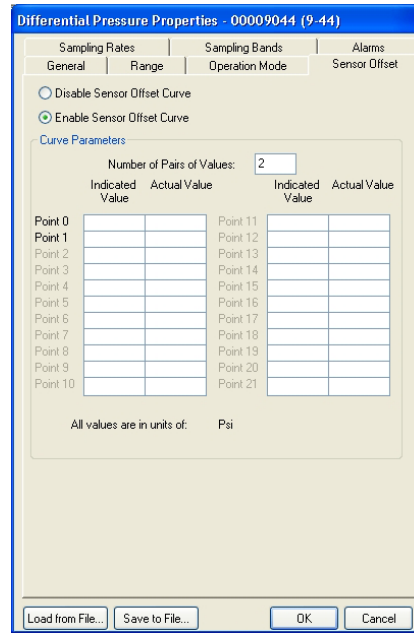

Figure 7.4: Setting a 22-Point Curve Using WMT

Selecting and Configuring Operation Modes

In this section the four operation modes: differential pressure, orifice flow, open channel flow, and level are discussed in order to aid the user in selecting the right mode for his or her application and properly configuring the Transmitter for that specific application. The subsections are as follows:

- 8.1: Differential Pressure
- 8.2: Orifice Flow
- 8.3: Open Channel Flow

8.1: Differential Pressure

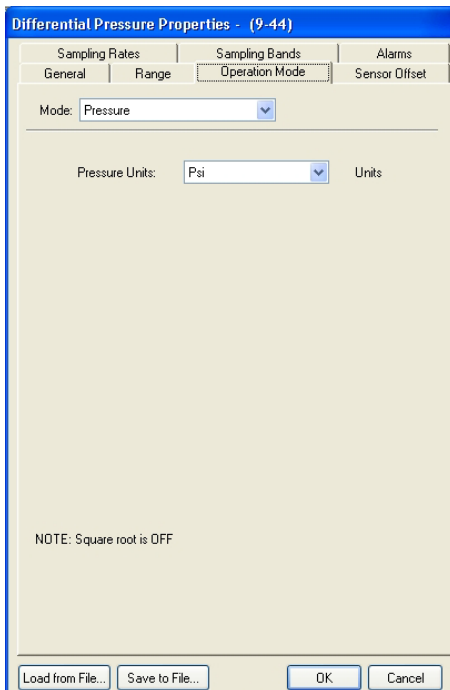

Figure 8.1: Differential Pressure Setting Using WMT

This mode simply calculates and displays the differential pressure value from the Differential Pressure sensor. To set the Transmitter to this operation mode, you must go to the configuration menu of the Transmitter via the Software. For further instructions on getting to the configuration menu see Section 9.2 of the Wireless Management Toolkit User Manual.

Once you have opened the configuration menu, select the **Operation Mode** tab at the top of the menu. You should then see a menu like the one shown in Figure 8.1.

To select the Differential Pressure mode, select **Pressure** in the **Mode** drop down box. This will display another drop down box which will allow the selection of differential pressure engineering units. You should select the units that are appropriate for your application. All possible units are listed below:

DPressure Units	Display Characters
Atmospheres	ATMS
Bar	BAR
Feet of H2O @ 68°F	FT H2O
Grams / cm ²	GMSQCM
Inches H2O @ 4°C	INH2O4C
Inches of H2O @ 68°C	IN H2O
Inches of HG (Mercury) @ 0°C	IN HG
Kilograms / cm ²	KG/SQCM
Kilo pascal	KPASCAL
Mega pascal	MPASCAL
Milli Bar	MBAR
Millimeters H2O @ 4°C	MMH2O4C
Millimeters of H2O @ 68°F	MM H2O
Mm of HG (Mercury) @ 0°C	MM HG
Pascals	PASCALS
Percent (%)	PER FS
Pounds per in ² (PSI)	PSI
Special	SPECIAL
Torr	TORR

Once engineering units have been selected, a 22-point sensor offset curve can be enabled (it is disabled upon delivery from the factory) by selecting the **Sensor Offset** tab within the configuration menu.

8.2: Orifice Flow

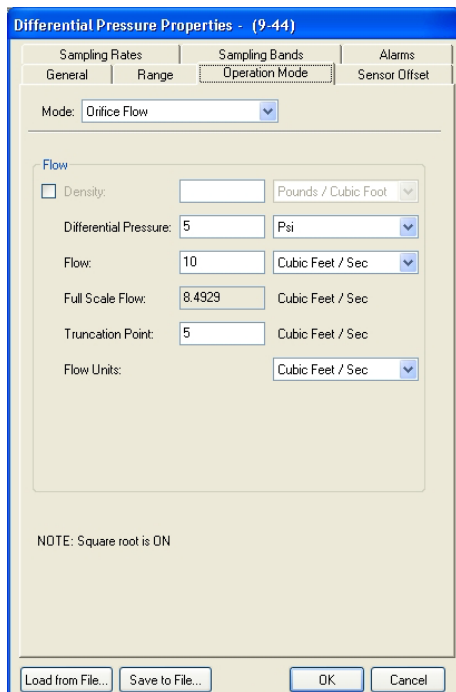

Figure 8.2: Orifice Flow

In this mode, the user has the option of setting up volumetric or mass flow calculations through an orifice plate, if the density units are selected and entered mass flow calculations are available. The user must enter a differential pressure value and a flow value corresponding to the pressure value. Using these two points, the PC will calculate the flow value that corresponds to the full-scale pressure value of the Transmitter (i.e., FS Flow). Finally, the user also must enter a truncation point value. This information is used to calculate flow in the units selected by the user.

To set the Transmitter to this operation mode, you must go to the configuration menu of the Transmitter via the Software. For further instructions on getting to the configuration menu see Section 9.2 of the Wireless Management Toolkit User Manual.

Once you have opened the configuration menu, select the **Operation Mode** tab at the top of the menu and select **Orifice Flow** from the mode menu. You should then see a menu like the one shown in Figure 8.2.

Select the units that are appropriate for your application. All possible units are listed below:

Orifice Flow Units	Display Characters
Barrels / Day	BBL/D
Barrels / Hr	BBL/ H
Barrels / Min	BBL/ M
Barrels / Sec	BBL/S
Cubic Feet / Day	CUFT/D
Cubic Feet / Hr	CUFT/HR
Cubic Feet / Min *	CUFT/M
Cubic Feet / Sec *	CUFT/S
Cubic Meter / Day *	CU M/D
Cubic Meter / Hr *	CU M/H
Cubic Meter / Min	CU M/M
Cubic Meter / Sec	CU M/S
Gallons / Day	GAL/D
Gallons / Hr	GAL/H
Gallons / Min	GAL/M
Gallons / Sec	GAL/S
Grams / Hr *	GM/H
Grams / Min *	GMM
Grams / Sec *	GM/S
Imperial Gal / Day	IMPG/D
Imperial Gal / Hr	IMPG/H
Imperial Gal / Min	IMPG/M
Imperial Gal / Sec	IMPG/S
Kilograms / Day *	KG/D
Kilograms / Hr *	KG/H
Kilograms / Min *	KG/M
Kilograms / Sec *	KG/S
Liters / Hr	L/H
Liters / Min	L/M
Liters / Sec	L/S

NOTE

* Starred units are only available once the Density check box has been selected.

8.2: Orifice Flow (cont.)

NOTE

** Percent Volume Flow may only be selected from the Flow Units list. It does not appear in the Flow list. Selecting Percent Volume Flow enables the Square Root Function. See section 8.2.1 for more information.

Orifice Flow Units	Display Characters
Long Tons / Day *	LTON/D
Long Tons / Hr *	LTON/H
Metric Tons / Day *	MTON/D
Metric Tons / Hr *	MTON/H
Metric Tons / Min *	MTON/M
Millions Gal / Day	MGAL/D
Millions Liters / Day	MILL/D
Normal Cubic Meters / Hr	NCUM/H
Normal Liters / Hr	NL/H
Percent - Mass Flow *	PER FS
Percent - Vol Flow **	PER FS
Pounds / Day *	LB/D
Pounds / Hr *	LB/H
Pounds / Min *	LB/M
Pounds / Sec *	LB/S
Short Tons / Day *	STON/D
Short Tons / Hr *	STON/H
Short Tons / Min *	STON/M
STD Ft ³ (Cubic Ft) / Min	SCUF/M

Once engineering units have been selected, a 22-point sensor offset curve can be enabled (it is disabled upon delivery from the factory) by selecting the **Sensor Offset** tab within the configuration menu.

8.2.1: Square Root Calculation

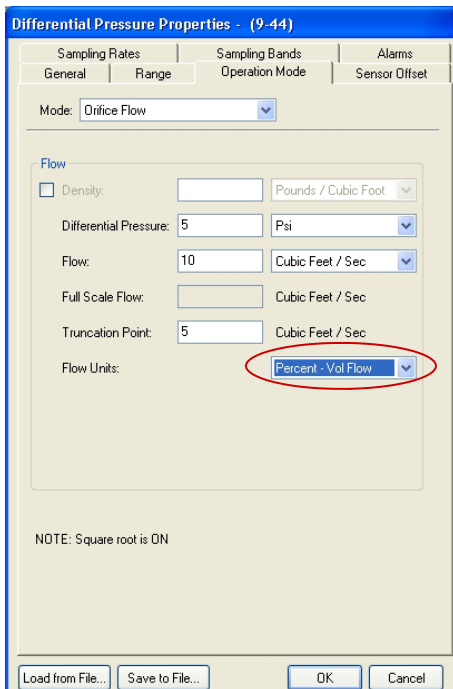

Figure 8.3: Orifice Flow with Square Root Calculation Enabled

When the Transmitter is in Orifice mode, a Square Root calculation is performed. You have the option to display the Square Root Calculation. If this option is enabled, it will be displayed as Percent Square Root in WMT and sent to a ModBus Register.

To display the Square Root Calculation, first make sure you have selected Orifice Flow from the mode menu. Then, from the Flow Units drop-down list, select **Percent - Vol Flow**. If the Density check box is selected, then **Percent - Mass Flow** can also be selected from the Flow Units drop-down list to show the Square Root Calculation.

8.3: Open Channel Flow

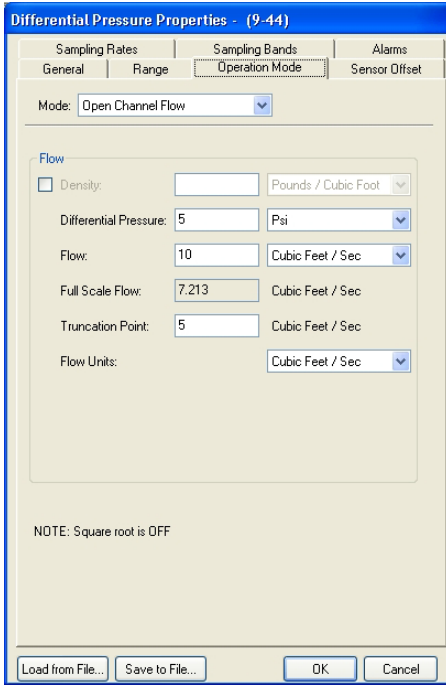

Figure 8.4: Open Channel Flow Mode

NOTE
For Open Channel Flow, a 22-point curve table must be filled out for correct operation.

This mode lets the user setup flow calculations for open channel flow measurements for weirs. In order to make this calculation, the user must enter the density of the material, a differential pressure value and a matching flow value. In addition, a truncation point value must be entered. Finally, the user **must** fill out the 22-point curve table indicating the relationship between column height and flow rate.

To set the Transmitter to this operation mode, you must go to the configuration menu of the Transmitter via the Software. For further instructions on getting to the configuration menu see Section 9.2 of the Wireless Management Toolkit User Manual.

Once you have opened the configuration menu, select the **Operation Mode** tab at the top of the menu and select **Open Channel Flow** from the mode menu. You should then see a menu like the one shown in Figure 8.3.

Select the units that are appropriate for your application. All possible units are listed below:

Open Channel Flow	Display Characters
Barrels / Day	BBL/D
Barrels / Hr	BBL/ H
Barrels / Min	BBL/ M
Barrels / Sec	BBL/S
Cubic Feet / Day	CUFT/D
Cubic Feet / Hr	CUFT/HR
Cubic Feet / Min	CUFT/M
Cubic Feet / Sec	CUFT/S
Cubic Meter / Day	CU M/D
Cubic Meter / Hr	CU M/H
Cubic Meter / Min	CU M/M
Cubic Meter / Sec	CU M/S
Gallons / Day	GAL/D
Gallons / Hr	GAL/H
Gallons / Min	GAL/M
Gallons / Sec	GAL/S
Grams / Hr	GM/H
Grams / Min	GMM
Grams / Sec	GMS
Imperial Gal / Day	IMPG/D
Imperial Gal / Hr	IMPG/H
Imperial Gal / Min	IMPG/M
Imperial Gal / Sec	IMPG/S
Kilograms / Day	KG/D
Kilograms / Hr	KG/H
Kilograms / Min	KG/M
Kilograms / Sec	KG/S

8.3: Open Channel Flow (cont.)

Open Channel Flow	Display Characters
Liters / Hr	L/H
Liters / Min	L/M
Liters / Sec	L/S
Long Tons / Day	LTON/D
Long Tons / Hr	LTON/H
Metric Tons / Day	MTON/D
Metric Tons / Hr	MTON/H
Metric Tons / Min	MTON/M
Millions Gal / Day	MGAL/D
Millions Liters / Day	MILL/D
Normal Cubic Meters / Hr	NCUM/H
Normal Liters / Hr	NL/H
Percent - Mass Flow	PER FS
Percent - Vol Flow	PER FS
Pounds / Day	LB/D
Pounds / Hr	LB/H
Pounds / Min	LB/M
Pounds / Sec	LB/S
Short Tons / Day	STON/D
Short Tons / Hr	STON/H
Short Tons / Min	STON/M
STD Ft ³ (Cubic Ft) / Min	SCUF/M

Once engineering units have been selected, a 22-point sensor offset curve **must** be enabled (it is disabled upon delivery from the factory) by selecting the **Sensor Offset** tab within the configuration menu.

8.4: Level

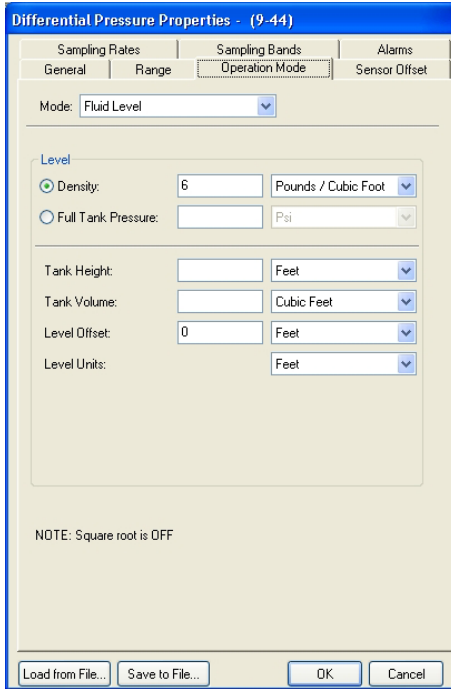

Figure 8.5: Level Mode

NOTE

For Level, a 22-point curve table must be filled out for correct operation.

In this mode, the user has the option of entering the density of material or the full tank pressure. Also, the user must enter tank height and tank volume. Finally, the user must select level units, which can be in units of height, volume, or mass. The entered information is used to make level calculations in the units selected by the user. For non-uniform tanks, the user must also fill out the 22-point curve table indicating the relationship between height and volume.

To set the Transmitter to this operation mode, you must go to the configuration menu of the Transmitter via the Software. For further instructions on getting to the configuration menu see Section 9.2 of the Wireless Management Toolkit User Manual.

Once you have opened the configuration menu, select the **Operation Mode** tab at the top of the menu and select **Fluid Level** from the mode menu. You should then see a menu like the one shown in Figure 8.4.

Level	Display Characters
Barrels	BBL
Bushels	BUSHELS
Centimeters	CM
Cubic Feet	CU FEET
Cubic Inches	CU INCH
Cubic Meters	CU M
Cubic Yards	CU YARD
Feet	FEET
Gallons	GALLONS
Grams	GRAM
HectoLiter	HLITER
Imperial Gallons	IMPGAL
Inches	INCHES
Kilograms	KGRAMS
Liquid Barrels	BBL LIQ
Liters	LITERS
Long Tons	LNG TON
Meters	METERS
Metric Tons	M TON
Millimeters	MM
Normal Cubic Meters	N CU M
Normal Liters	N LITER
Ounce	OUNCE
Percent - Height	PER FS
Percent - Mass	PER FS
Percent - Volume	PER FS
Pounds	POUNDS
Short Tons	SHT TON
Standard Cubic Feet	SCFEET

Once engineering units have been selected, a 22-point sensor offset curve **must** be enabled (it is disabled upon delivery from the factory) by selecting the **Sensor Offset** tab within the configuration menu.

Maintaining the Transmitter

The Differential Pressure Transmitter is extremely easy to maintain in that it requires no periodic calibration or system checks. The Transmitter has a self-diagnostic that is constantly checking the internal system. If any errors are found they are reported via the LCD, Base Radio or in the WMT. A simple yearly visual inspection for the following is all that is needed:

- Is the Transmitter still securely fastened to the equipment being monitored?
- Are there any visible corrosions, cracks or residue build-ups on the unit?
- Has anything about the application changed from the original intended use?



9.1: Changing the Battery

The battery will need to be changed within one month of seeing a ‘LOW BAT’ message on the Transmitter. This is a simple process:

1. Make sure you have the correct replacement battery:

TADIRAN™ Lithium Inorganic Battery (non-rechargeable)
Size “C” – 3.6Volts
#TL2200/S

2. Power down the Transmitter by pressing and holding both the NEXT and ENTER buttons for a few moments.
3. Remove the 4 set screws on the sides of the Transmitter housing with a standard screw driver.
4. Remove the housing and locate the battery. Warning! When removing the housing do not twist or bend the green flex cable! Doing so may cause the tether to improperly seat next to the antenna and greatly reduce operable RF distances. Do not allow the housing to flop around while hanging by the tether.
5. Remove the old battery and replace it with the new battery positive end first. **(Note that the positive end of the battery clip is the end with the red wire).**
6. Plug the green wire flex cable back in if unplugged and replace the housing. Then, screw the housing back on, and power up the unit by pressing either of the buttons.
7. Properly dispose of used battery.

 Warning 
<p>When removing the housing do not twist or bend the green flex cable! Doing so may cause the tether to improperly seat next to the antenna and greatly reduce operable RF distances. Do not allow the housing to flop around while hanging by the tether.</p>

Technical Specifications

Differential Pressure Input Characteristics

Model	Upper (URL) and Lower Range Limit	Maximum Static Pressure
WD520	± 100 in H ₂ O	2000 PSI
WD521	± 300 in H ₂ O	2000 PSI
WD522	± 25 PSI	2000 PSI
WD523	+ 100, - 25 PSI	2000 PSI
WD524	+ 300, - 25 PSI	2000 PSI

Accuracy

- ± 0.2 % of full-scale reading including combined effects of temperature, hysteresis and repeatability

Stability

- Less than ± 0.25 % of sensor URL per year at reference temperature

Return from Overpressure

- ± 0.04 %

Sensitivity in Reverse Pressure Direction

- Within 1.0 % of forward direction

Mounting and Positioning Effect

- ± 1.5 In H₂O, correctable with position zero

Output Resolution

- See the Base Radio description for analog and digital output options

Operating Temperature Range

- -40°F to +220°F (-40°C to +104°C) process connection temperature, steady state
- -40°F to +185°F (-40°C to +85°C) electronics
- -4°F to +158°F (-20°C to +70°C) display (full visibility)
- -40°F to +185°F (-40°C to +85°C) display (with reduced visibility)
- Humidity Limits: 0 to 100 %

Sampling and Transmission Characteristics

The Differential Pressure Transmitter samples differential pressure or flow at regular intervals. The data may then be transmitted to the Base Radio for centralized monitoring and data acquisition. The user specifies how frequently the process is monitored and how often data is transmitted.

- Differential Pressure/Flow – user designates low rate and high rate conditions
- Sampling rate – user selectable from 1 to 60 seconds (low rate) and from 1 to 30 seconds (high rate)
- Transmission rate – user selectable from 1 second to 60 seconds (low and high rate)

Power Characteristics

- Self-contained power
- 'C' Size 3.6 V lithium battery
- Up to five year battery life (depends on sample rate and RF update rate), field replaceable

RF Characteristics

- 902 MHz – 928 MHz Frequency Hopping Spread Spectrum (FHSS), FCC certified ISM license-free band
- Up to 3000' range from Base Radio with clear line of sight; 500' to 1000' range with obstructions
- The RF module in each transmitter is individually tested and calibrated over the full temperature range to ensure reliable wireless operation

Self-Diagnostics

Low battery alarm – indicates the need to replace the battery (approximately one month warning)

- Contains extensive self-checking software and hardware that continuously monitors the operation. Any sensor or device parameter out of spec is identified and reported

Materials of Construction

- Type 316 stainless steel base
- Type 316 stainless steel diaphragm (Hastelloy C is available upon special request)
- Type 316 stainless steel flange and bolts (Hastelloy C is available upon special request)
- DC 200 silicone sensor filling fluid (Florolube available upon special request)
- Weight approximately 6.2 lbs (2.8 kgs)
- GE Lexan® cover. V-0 rating and UV stable

Operating Vibration and Shock Characteristics

- Certified per IEC 60068-2-6 (vibration) and 2-27 (shock)

Random Vibration Characteristics

- Certified to withstand 6 g's, 15 minutes per axis from 9 – 500 Hz

Electromagnetic Compatibility (CE Compliance)

- Operates within specification in fields from 80 to 1,000 MHz with field strengths to 10 V/m. Meets EN 50082-1 general immunity standard and EN 55011 compatibility emissions standard

Industrial Certification, Pending

- Rated for industrial use -40°F to 185°F (-40 °C to 85°C)
- Pending: FM NEMA 4X weather-proof housing
- Pending: FM rated intrinsically safe for Class I/II/III, Division 1, Groups A, B, C, D, E, F & G; Class I/II/III, Division 2, Groups A, B, C, D, F & G.

Intrinsic Safety Entity Parameters, Pending

- Maximum operating temperature = 85°C
- Temperature Class T4

Configuration

The Wireless Management Toolkit is required for initial set-up and ongoing configuration. Options include a 22-point custom curve capability.

The Wireless Management Toolkit can also be used for monitoring of the process information. The user can set thresholds to represent “alarm” or abnormal conditions.

A local display provides:

- Integrated LCD display with membrane switch buttons
- Display provides pressure reading and error messages, if applicable
- Configure RF parameters locally using membrane switch buttons

Mounting Bracket

The optional mounting bracket, model suffix –SB, can be ordered separately.

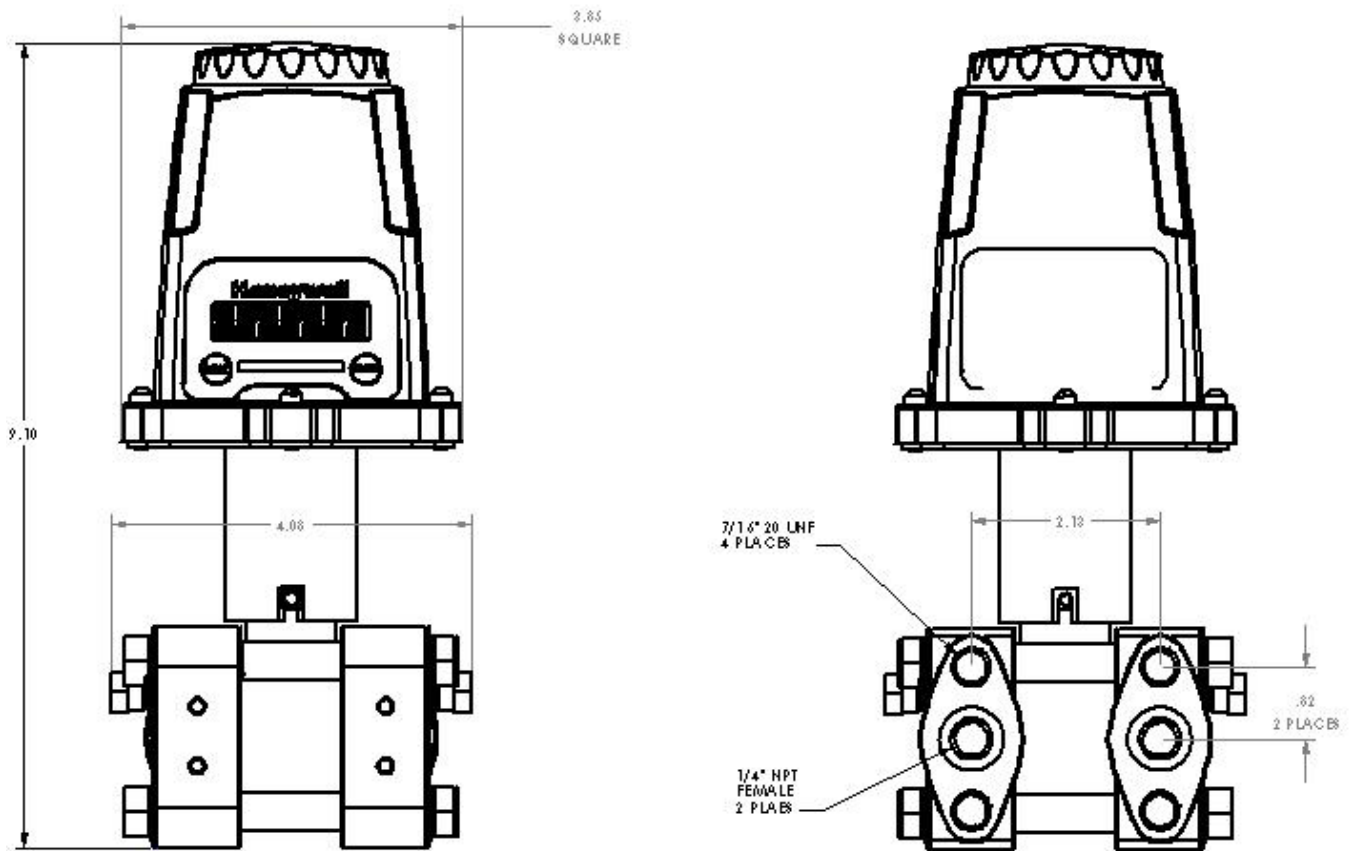

Navigating User Menus

Pressing either the NEXT or ENTER buttons located on the front of the Transmitter or Base Radio just below the Liquid Crystal Display (LCD) screen is all that is needed to navigate the respective menus. Pressing both of these buttons for one second will turn the unit on.

Pressing the NEXT button at any time while the Transmitter is cycling through the normal messages causes the Transmitter to enter the setup mode. The NEXT button is then used to step through menu options, and the ENTER button is used to enter a sub menu of what is displayed on the LCD at that time. If no button is pressed within a 30 second period the unit goes back to the normal display mode.

If you enter a sub menu that requires a numerical input, such as 001, the left most 0 will be blinking. This indicates that pressing the NEXT button will increment this value with each press from 0 to 9 and back to 0 again. Pressing the ENTER button will move to the next available value. If the last value is blinking, pressing ENTER will save the entered values and return from the sub menu.

If both the NEXT and ENTER buttons are depressed at once, a message on the LCD displaying OFF? will appear. If both buttons are released upon appearance of this message the user will be returned to the scrolling main screen. If both buttons are not released for the duration of the OFF? message the unit will power down and turn off. Note: If the unit is turned off while entering values in a sub menu, those values will NOT be saved.

* As shown throughout the document, this mark indicates that these menu options will automatically turn off if the Wireless Management Toolkit Software is used. All changes to these Transmitter menu options should be made through software instead. This is to prevent simultaneous changes from taking place. If you wish to discontinue use of the software and want these menus re-instated, you must contact your Honeywell Sales Representative.

Transmitter Displayed Message Definitions

This section covers the various messages, displayed on the Transmitter LCD, that occur during operation of the device.

Operations Sequence

- **RF Link Status**
 - ⇒ RF OK – Transmitter and Base Radio are communicating properly
 - ⇒ RF SYNC - Transmitter and Base Radio are attempting to synchronize communications.
 - ⇒ RF OFF - Transmitter's RF Channel is set to RF OFF
 - ⇒ NO RF - Transmitter and Base Radio have no communications
- **Differential Pressure Input Level**
 - ⇒ -XX.XX – Currently measured differential input level

Error Messages

If an error is detected with the operation of the Transmitter a message will be displayed on the Transmitter LCD (a corresponding message may also appear on the Base Radio LCD).

There are few types of error messages, warning and fatal. Warning messages are displayed as part of the normal cycling message sequence. These are:

- **LOW BAT** - battery should be replaced as soon as possible
- **NO RF** - can not detect Base Radio
- **S FAULT** - there is an open sensor or excitation wire detected. Also if a sensor value goes above/below logical limits. The unit will display 9999.99 for measurement (sensor fault mode); but will continue sampling and recover if the problem desists.
- **OVERRNG** - the device is measuring a value above/below sensor dependent bound values. For example the Analog Input device will report over-range if measurement is above 105% range of the Analog Input sensor. If the measurement goes above 150% full range, the unit will go into Sensor Fault mode. In over-range mode, the measurement is continued to be displayed, with the "OVERRNG" message to remind the user that the specified range of the sensor and the calibrated range of the device is being exceeded.

Fatal error messages will replace the normal cycling message sequence and will flash. A fatal message indicates the Transmitter is no longer operating normally and requires repair. These are:

- **RF ERR** - fatal error within RF communications
- **SEN ERR** - fatal error within the sensor electronics
- **SYS ERR** - fatal error within the microprocessor system
- **RF CAL** - fatal error within the RF calibration system

Transmitter Menu Map

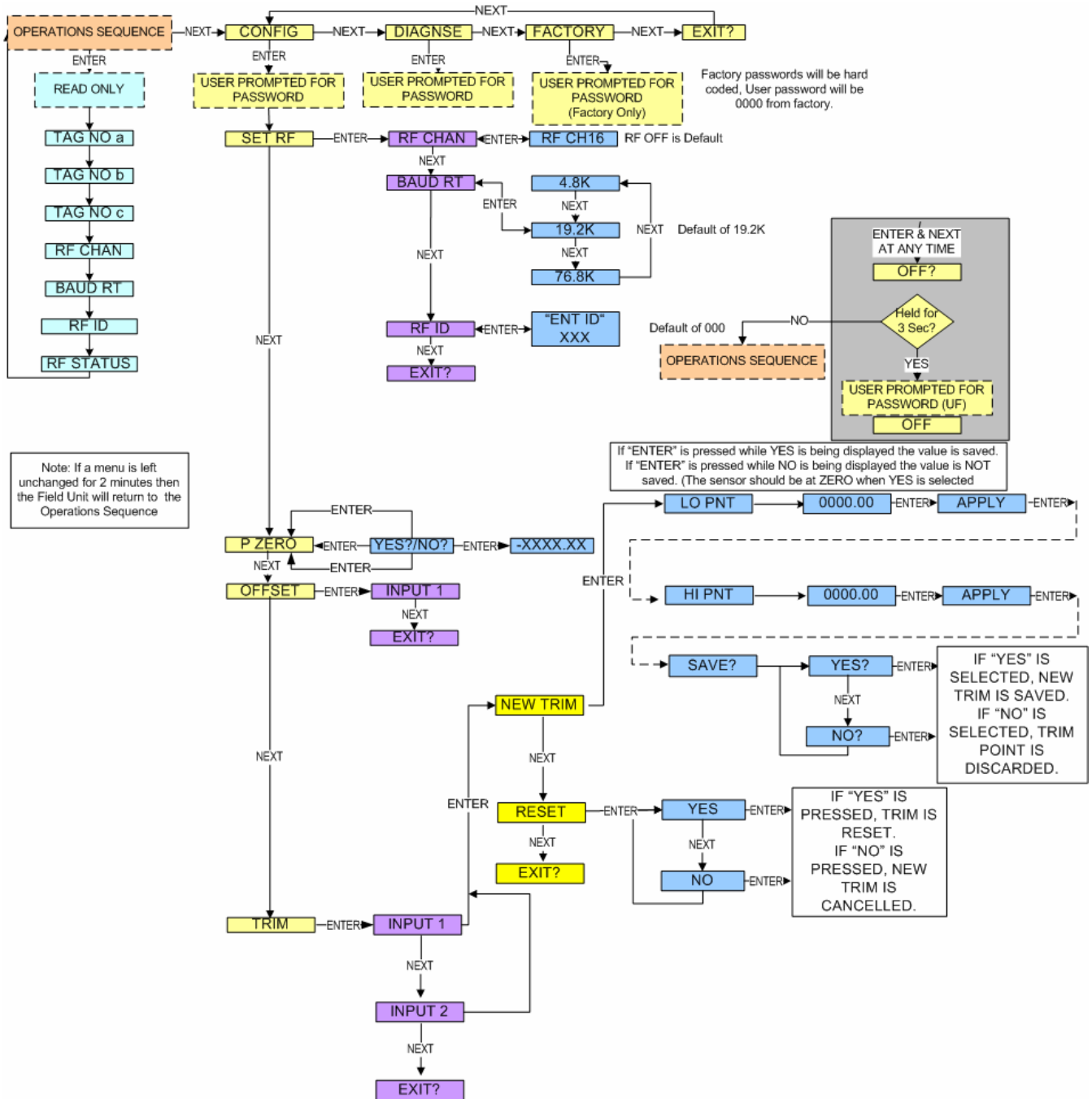

Modbus Register Definitions

```

/* Pressure Units */
InH2OAt68F      = 1,    /* inches of water at 68 degF */
InHgAt0C        = 2,    /* inches of mercury at 0 degC */
FtH2OAt68F      = 3,    /* feet of water at 68 degF */
MMH2OAt68F      = 4,    /* millimeters of water at 68 degF */
MMHgAt0C        = 5,    /* millimeters of mercury at 0 degF */
PSI              = 6,    /* pounds per square inch */
BAR              = 7,    /* bars */
MilliBAR        = 8,    /* millibars */
GMPerSqCm       = 9,    /* grams per square centimeter */
KGPerSqCm       = 10,   /* kilograms per square centimeter */
Pascals         = 11,   /* pascals */
KiloPascals     = 12,   /* kilopascals */
Torr            = 13,   /* torricellis */
Atmospheres     = 14,   /* atmospheres */
PSIA            = 175,  /* pounds per square inch absolute */
FtH2OAt4C       = 177, /* feet of water at 4 degC */
MetHgAt0C       = 179, /* meters of mercury at 0 degC */
MegaPascals     = 237,  /* megapascals */
InH2OAt4C       = 238, /* inches of water at 4 degC */
MMH2OAt4C       = 239, /* millimeters of water at 4 degC */

/* Volumetric Flow Units */
CuFtPerMin      = 15,   /* cubic feet per minute */
GalPerMin       = 16,   /* gallons per minute */
LiterPerMin     = 17,   /* liters per minute */
ImpGalPerMin    = 18,   /* imperial gallons per minute */
CuMeterPerHr    = 19,   /* cubic meter per hour */
GalPerSec       = 22,   /* gallons per second */
MillionGalPerDay = 23,  /* million gallons per day */
LiterPerSec     = 24,   /* liters per second */
MillionLiterPerDay = 25, /* million liters per day */
CuFeetPerSec   = 26,   /* cubic feet per second */
CuFeetPerDay   = 27,   /* cubic feet per day */
CuMeterPerSec  = 28,   /* cubic meters per second */
CuMeterPerDay  = 29,   /* cubic meters per day */
ImpGalPerHr    = 30,   /* imperial gallons per hour */
ImpGalPerDay   = 31,   /* imperial gallons per day */
NormCuMeterPerHr = 121, /* normal cubic meter per hour - MKS System */
NormLiterPerHr  = 122, /* normal liter per hour - MKS System */
StdCuFtPerMin  = 123,  /* standard cubic feet per minute - US System */
CuFeetPerHour  = 130,  /* cubic feet per hour */
CuMeterPerMin  = 131,  /* cubic meters per minute */
BarrelPerSec   = 132,  /* barrels per second - 1 Barrel = 42 US gallons */
BarrelPerMin   = 133,  /* barrels per minute */
BarrelPerHr    = 134,  /* barrels per hour */
BarrelPerDay   = 135,  /* barrels per day */
GalPerHr       = 136,  /* gallons per hour */
ImpGalPerSec   = 137,  /* imperial gallons per hour */
LiterPerHr     = 138,  /* liters per hour */
GalPerDay      = 235,  /* gallons per day */

```



```

/* Volume Units */
Gallons      = 40, /* gallons */
Liters       = 41, /* liters */
ImpGallons   = 42, /* imperial gallons */
CuMeters     = 43, /* cubic meters */
Barrels      = 46, /* barrels */
Bushels      = 110, /* bushels */
CuYard       = 111, /* cubic yards */
CuFeet       = 112, /* cubic feet */
CuInch       = 113, /* cubic inches */
BarrelsLiquid = 124, /* liquid barrels - 1 bbl liq = 31.5 US gallons */
/*
NormalCuMeter = 166, /* normal cubic meter - MKS System */
NormalLiter   = 167, /* normal liter - MKS System */
StdCuFeet     = 168, /* standard cubic feet - US System */
HectoLiter    = 236, /* hectoliters */

/* Length Units */
Feet         = 44, /* feet */
Meters       = 45, /* meters */
Inches       = 47, /* inches */
CM           = 48, /* centimeters */
MM           = 49, /* millimeters */
FtInSixteenths = 151, /* see Note 1 in HART document HCF_SPEC-183 */

/* Mass Units */
Gram         = 60, /* grams */
KG           = 61, /* kilograms */
MetricTon    = 62, /* metric tons */
Pound        = 63, /* pounds */
ShortTon     = 64, /* short tons */
LongTon      = 65, /* long tons */
Ounce        = 125, /* ounce */

/* Mass Flow Units */
GramPerSec   = 70, /* grams per second */
GramPerMin   = 71, /* grams per minute */
GramPerHr    = 72, /* grams per hour */
KGPerSec     = 73, /* kilograms per second */
KGPerMin     = 74, /* kilograms per minute */
KGPerHr      = 75, /* kilograms per hour */
KGPerDay     = 76, /* kilograms per day */
MetTonPerMin = 77, /* metric tons per minute */
MetTonPerHr  = 78, /* metric tons per hour */
MetTonPerDay = 79, /* metric tons per day */
PoundsPerSec = 80, /* pounds per second */
PoundsPerMin = 81, /* pounds per minute */
PoundsPerHr  = 82, /* pounds per hour */
PoundsPerDay = 83, /* pounds per day */
ShTonPerMin  = 84, /* short tons per minute */
ShTonPerHr   = 85, /* short tons per hour */
ShTonPerDay  = 86, /* short tons per day */
LongTonPerHr = 87, /* long tons per hour */
LongTonPerDay = 88, /* long tons per day */

```

```
/* Density Units */
SGU = 90, /* specific gravity units */
GramPerCuCm = 91, /* grams per cubic centimeter */
KGPerCuMeter = 92, /* kilograms per cubic meter */
PoundsPerGal = 93, /* pounds per gallon */
PoundsPerCuFt = 94, /* pounds per cubic foot */
GramsPerML = 95, /* grams per milliliter */
KGPerLiter = 96, /* kilograms per liter */
GramsPerLiter = 97, /* grams per liter */
PoundsPerCuIn = 98, /* pounds per cubic inch */
ShTonPerCuYard = 99, /* short tons per cubic yard */
DegTwad = 100, /* degrees twaddell */
DegBaumHeavy = 102, /* degrees baume heavy */
DegBaumLight = 103, /* degrees baume light */
DegAPI = 104, /* degrees API */

/* Analytical Units */
Percent = 57, /* percent */

/* Special Units */
SpecialUnits = 253
```

17345

Honeywell

Industrial Measurement and Control

2500 W. Union Hills Drive
Phoenix AZ, 85027