

# Knife gate valve XV



*Data is only for informational purpose. All specifications are subject to change without notice.*

## Knife gate valve XV

Stafsjö's knife gate valve XV gives a secure and tight shut-off, independent of pressure direction. The valve has good flow characteristics and can be used in applications with pulp, water and sludge, and the Polyurethane seated version further extend its field of applications to abrasive media such as light slurry.

The XV valve is supplied with valve body, gate, retainer rings and gland in stainless steel. The valve body is available in two versions; fully lugged and semi lugged. The valve comes with the retainer ring system on both sides of the gate, which makes it independent of pressure direction and very easy to maintain. In spite of its relatively low weight and compact design the valve is able to cope with high bi-directional pressures. The gland box is equipped with three layers of Stafsjö's box packing TwinPack™ and a box bottom scraper of UHMWPE, to secure that no media reaches the surrounding environment.

The top work consists of aluminium beams and stainless steel tie rods, which gives good corrosion resistance and a stable operation. The valve is modular designed and can easily be customized to specific processes requirements. There are several actuator types and accessories to choose from in our standard collection.

The XV valve is designed, manufactured, inspected and tested according to the European Pressure Equipment Directive (PED 97/23/EC) category I and II module A1. The valve is CE marked when it is applicable.



### Double retainer ring system makes it bi-directional tight

The retainer ring system on both sides of the gate makes it independent of pressure direction and it also offers simple on-site maintenance.



### Self-cleansing function

The gate and the bump in the invert of the valve raise the speed of the media upon closure, forcing the media out of the valve and into the pipe. The valve cleans itself each time it closes.

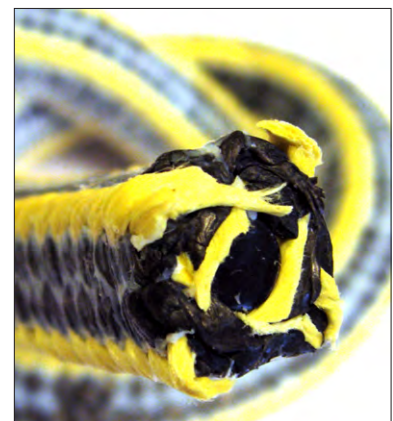

### A first-rate sealing

A gland box supplied with three layers of our TwinPack™, which is specially developed and made for Stafsjö's valves, and a box bottom scraper, secures that no media reaches the surrounding environment.

## Design data

Sizes	Flange drilling	Face-to-face dimension	ATEX Design
DN 80 - DN 800	EN 1092 PN10 ASME/ANSI B16.5 Class 150 ASME/ANSI B16.47 Class 150 series A AS 2129 Table D AS 2129 Table E JIS B 2238 10K	Semi lugged version ≤ DN 300: EN 558-1 series 20  Other sizes and versions: Stafsjö manufacturing standard MSS SP-81 TAPPI TIS 405-8	ATEX 94/ 9/EC II cat 3 G/D for zone 2 and 22 on request

Other sizes on request

Leakage rate	Pressure test
EN 12266-1:2012 Rate A: no visually detectable leakage is allowed for duration of the test MSS SP-81	Pressure tests are performed with water at 20° C according to EN 12266-1:2012. Pressure shell test: 1,5 times maximum allowable working pressure for open valve. Pressure seat tightness test: 1,1 times maximum allowable differential pressure for closed valve.
Maximum working pressure body at 20°C	Maximum differential pressure at 20°C
DN bar	DN bar
<i>Valve equipped with PTFE seats</i>	
80 - 150 16	80 - 350 10
200 - 600 10	400 - 600 6
700 - 800 6	700 - 800 4
<i>Valve equipped with Polyurethane seats</i>	
80 - 150 16	80 - 300 6
200 - 300 10	

## Basic equipment

A. Valve body			
Material	Code	Type	Maximum temperature °C
Stainless steel	(E)	EN 1.4408	400
B. Gate			
Material	Type		
Stainless steel	EN 1.4404/AISI 316L/SS 2348		
C. Retainer rings			
Material	Type		
Stainless steel	EN 1.4408		
D. Seats			
Material	Code	Maximum temperature °C	
Polyurethane	(U)	90	
PTFE with o-ring Nitrile	(P)	100	
PTFE with o-ring Viton	(PV)	180	
E. Box packing			
Material	Code	Maximum temperature °C	
TwinPack™ with scraper in UHMWPE (DN 80 - DN 600)	(TY)	80	
<i>Option</i>			
TwinPack™ with PTFE scraper	(TYP)	260	

## Actuators

Manual	Code	Automatic	Code
Hand wheel <sup>1)</sup>	(HW)	Pneumatic cylinder	(AC)
Chain wheel <sup>2)</sup>	(CW)	Electric motor	(EM)
		Hydraulic cylinder <sup>2)</sup>	(MH)

<sup>1)</sup> For recommended size, see page 5 column E.

<sup>2)</sup> For recommended size, see separate data sheet.

Double-acting pneumatic cylinder			Electric motor (AUMA multi-turn)		
DN valve	EC type	Maximum force (kN)	DN valve	AUMA type	Attachment
80 - 150	EC100	3,5	80 - 150	SA 07.2	F10/A
200 - 300	EC160	9,0	200 - 250	SA 07.6	F10/A
350 - 500	EC200	14,1	300 - 600	SA 10.2	F10/A
600 - 700	EC250	22,1	700 - 800	SA 14.2	F14A
800	EC320	36,2			

The table above gives recommended cylinder sizes at normal operation with 5 bar air pressure. For other operating conditions, please contact Stafsjö or your local representative for advice.

Electric motors are mounted according to standard ISO 5210. The table above gives recommended motor sizes at normal operation. For other operating conditions, please contact Stafsjö or your local representative for advice.

The actuators are described in separate data sheets. For advice and information on other actuators or on ATEX-classified ones, please contact Stafsjö or your local representative.

## Options and accessories

Knife gate valve			
Accessories	Code	Model	Design
Mechanical limit switch	(MLS)	Omron D4V	12-250 V AC/12-125 V DC, IP 65
Inductive limit switch	(ILS)	ifm electronic IG0006	2-wire, 20-250 V AC/DC, IP 67
		ifm electronic IG5401	3-wire, 10-36 V DC PNP, IP 67
Stem extension	(SES)	Short	Pipe Length < 1,5 m
	(SEL)	Long	Pipe Length > 1,5 m
Pneumatic cylinder			
Accessories	Code	Model	Design
Solenoid valve	(SV)	Parker Namur valves for EC 100 - EC 160	G1/4", Mono stable 5/2, Namur series VDI/VDE 3845, 24 V DC/110 V AC/220 V AC, IP 65
		Parker Namur valves for EC 200 - EC 320	G1/2", Mono stable 5/2, Namur series VDI/VDE 3845, 24 V DC/110 V AC/220 V AC, IP 65
Magnetic limit switch	(MagLS)	KITA KT-50R for EC 100 - EC 320	2-wire, 5-240 V AC/DC, IP 65
		KITA KT-50N for EC 100 - EC 320	3-wire, 10-30 V DC, IP 65

The accessories are described in separate data sheets. For advice and information on other accessories or on ATEX-classified ones, please contact Stafsjö or your local representative.

## Specify the Stafsjö valve

Stafsjö's valves are modular designed and they can easily be customized with gate, seat and box packings according to media and requirements, as well for actuators and accessories. Below are examples of how you can specify your Stafsjö valve. Further information is available on [www.stafsjo.com](http://www.stafsjo.com).

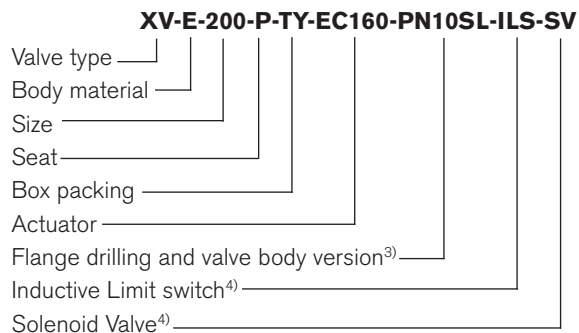
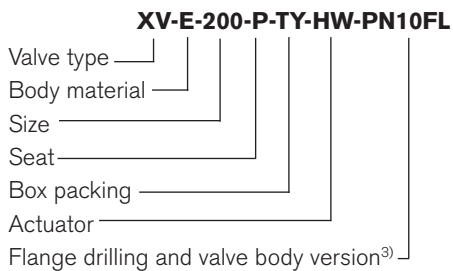

<sup>3)</sup> Type of valve body must be specified, i.e. fully lugged (FL) or semi lugged (SL)

<sup>4)</sup> All electronics must be specified in detail.

ILS: IFM IG0006, 2-draht 20-250V AC/DC

SV: Parker Namur ventil G1/2", 5/2, 220V AC

One piece valve body: DN 80 - DN 600

Two piece valve body: DN 700 - DN 800

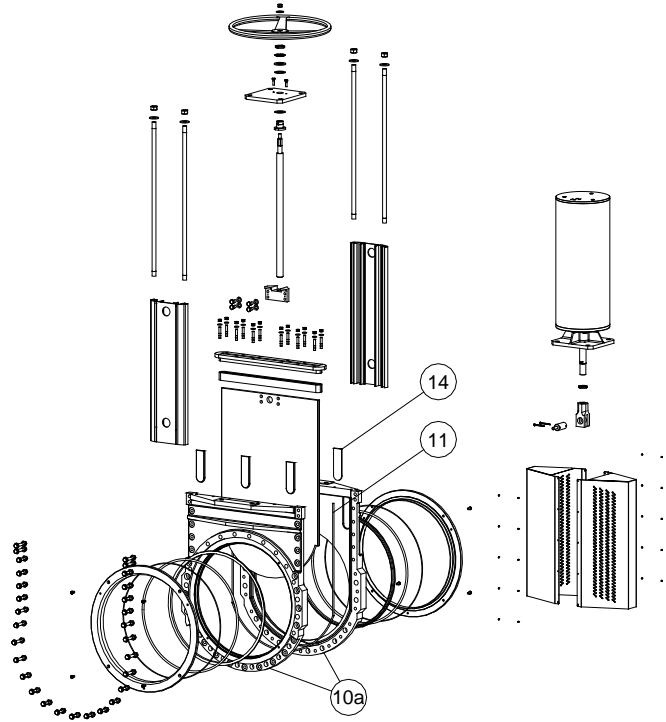
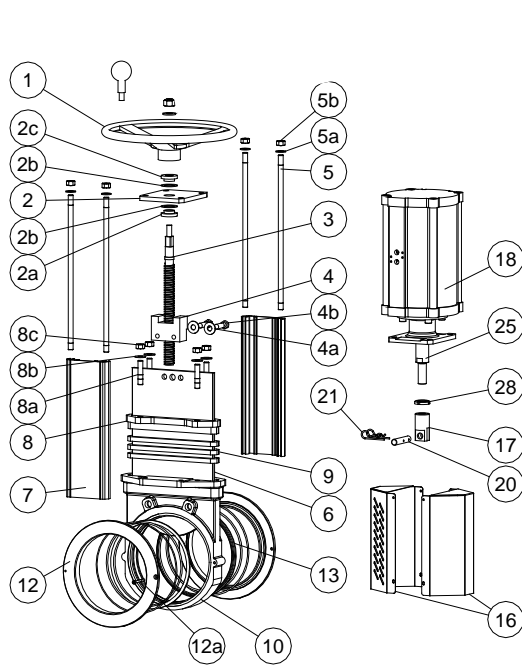

## Part list

Pos.	Part	Material (Type)
1	Hand wheel	Epoxy coated cast iron Ø 200 - Ø 315 (EN-JL1040/GG25), ≥ Ø 400 (EN-JL1030/GG20)
2	Yoke	Stainless steel (EN 1.4301/SS 2333)
2a	Bearing	Brass (CuZn39Pb3/SS 5170)
2b	Slide washer	POM
2c	Bearing	Brass (CuZn39Pb3/SS 5170)
3	Stem	Stainless steel (EN 1.4016/SS 2320)
4	Stem nut	Brass (CW603N)
4a	Washer	Stainless steel (A2)
4b	Screw	Stainless steel (A2)
5	Tie rod	Stainless steel (EN 1.4301/SS 2333)
5a	Washer	Stainless steel (A2)
5b	Nut	Stainless steel (A2)
6	Gate	See basic equipment B
7	Beam	Aluminium (EN AW-6063-T6)
8	Gland	Stainless steel (EN 1.4408)
8a	Stud bolt	Stainless steel, zinc coated (A2)
8b	Washer	Stainless steel (A2)

Pos.	Part	Material (Type)
8c	Nut	Stainless steel, zinc coated (A2)
9 <sup>5)</sup>	Box packing	See basic equipment E
10/a	Valve body	See basic equipment A
11	Body gasket	PTFE
12	Retainer ring	See basic equipment C
12a	Locking screw	Stainless steel (A2)
13 <sup>5)</sup>	Seat	See basic equipment D
14	Guiding pad	PTFE
16	Gate guard, not for HW	Stainless steel (EN 1.4301/SS 2333)
17	Gate clevis	Stainless steel (EN 1.4305/SS2346)
18	Cylinder	See data sheet for EC
19	O-ring	See basic equipment D
20	Clevis pin	Stainless steel (EN 1.4305/SS 2346)
21	Split pin	Stainless steel (EN 1.4436/SS 2343)
25	Piston rod	Stainless steel (EN 1.4305/SS 2346)
28	Locking nut	Stainless steel (EN 1.4305/SS 2346)

<sup>5)</sup> Recommended spare parts

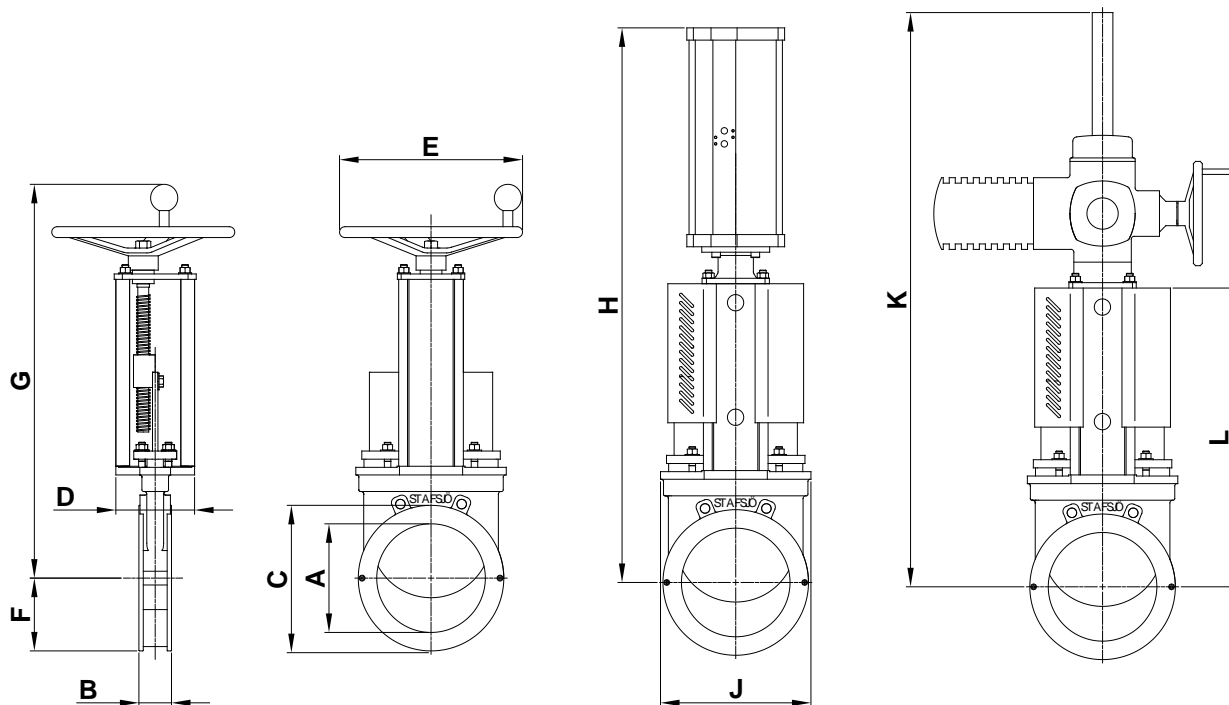

## Main dimensions for valve with semi lugged valve body

Dimension (mm)												
DN	A	B	C	D	E	F	G	H	J	K	L	Weight <sup>6)</sup>
80	80	46	138	80	200	69	444	552	140	690	314	8
100	100	52	158	80	200	79	482	590	158	728	352	10
125	125	56	188	80	250	94	523	681	188	769	393	13
150	150	56	212	80	250	106	567	725	212	813	437	15
200	200	60	269	145	315	135	691	912	277	868	546	30
250	250	68	322	145	315	161	785	1111	331	994	640	41
300	300	78	372	145	315	186	879	1205	382	1149	734	57
350	350	78	432	175	400	216	1021	1508	437	1308	841	-
400	400	89	481	175	400	241	1116	1603	488	1453	936	-
500	500	114	586	250	520	302	1342	1939	603	1770	1152	-
600	600	114	686	260	635	343	1546	2230	735	2076	1356	-
700	680	128	800	320	635	450	1650	2571	902	2382	1527	-
800	780	128	901	320	635	500	1866	2888	1002	2697	1742	-

<sup>6)</sup> Weight in kg for valve equipped with hand wheel.

Main dimensions are only for information. Contact Stafsjö for certified drawings.

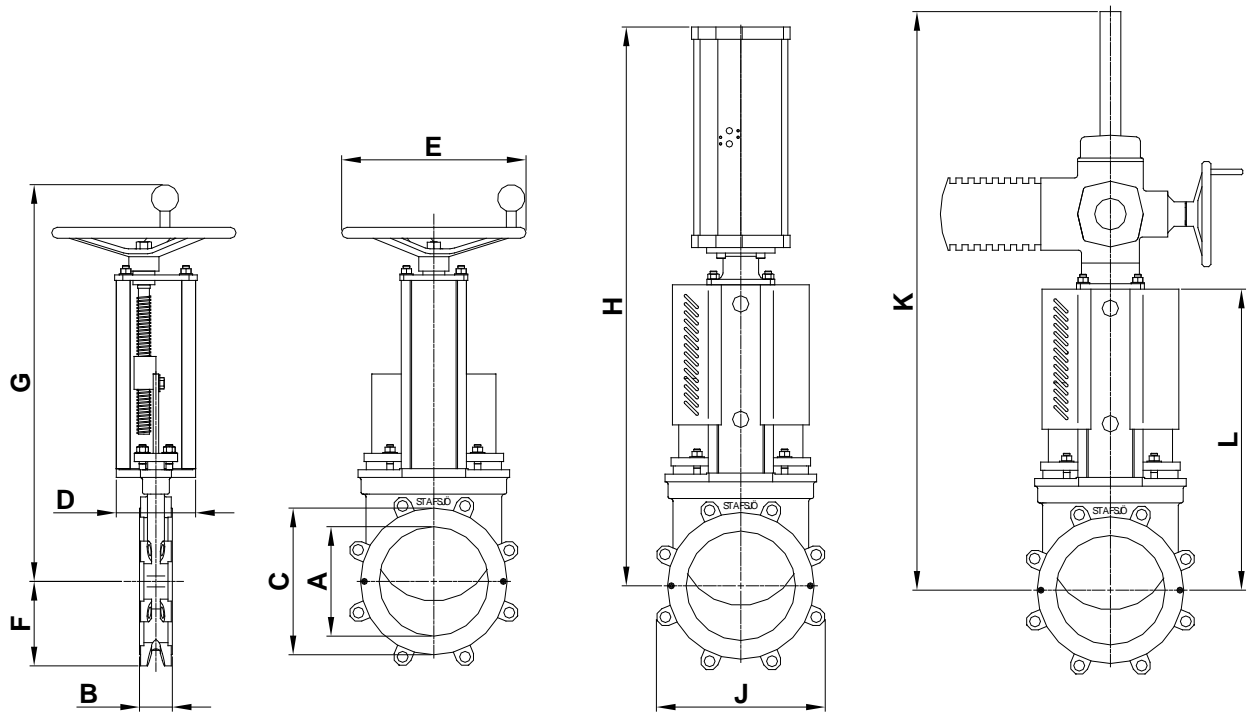

## Main dimensions for fully lugged valve body

Dimension (mm)														
Size	A	B	C <sup>9)</sup>	C <sup>10)</sup>	C <sup>11)</sup>	D	E	F	G	H	J	K	L	Weight <sup>7)</sup>
80	80	50	123	123	128	80	200	89	444	582	177	690	314	10
100	100	52	154	154	158	80	200	101	482	620	202	728	352	13
125	-	-	-	-	188	-	-	-	-	-	-	-	-	-
150	150	56	212	209	212	80	250	128	567	755	255	813	437	16
200	200	60 <sup>8)</sup>	268	266	268	145	315	155	691	1006	309	868	546	30
250	250	68	322	322	322	145	315	195	785	1100	389	994	640	48
300	300	78	372	372	372	145	315	229	879	1244	457	1149	734	63
350	350	78	432	432	432	175	400	256	1021	1477	512	1308	841	100
400	400	89	481	481	481	175	400	288	1116	1622	576	1453	936	135
450	450	89	531	531	531	200	520	309	1263	1843	618	1591	1056	170
500	500	114	586	586	586	250	520	340	1342	1988	681	1770	1152	200
600	600	114	686	686	686	260	635	400	1546	2329	799	2076	1356	370
700	680	128	800	800	800	320	635	450	1650	2475	902	2382	1527	-
800	780	128	901	901	901	320	635	500	1866	2952	1002	2697	1742	-

<sup>7)</sup> Weight in kg for valve equipped with hand wheel.

<sup>8)</sup> Face-to-face (B) is 70 mm for valve with PTFE seats and flange drilling according to ASME/ANSI B16.5 and B16.47 Class 150 series A.

<sup>9)</sup> Dimensions for valve with flange drilling according to EN 1092 PN10 or AS Table D.

<sup>10)</sup> Dimension for valve with flange drilling according to AS Table E.

<sup>11)</sup> Dimensions for valve with flange drilling according to ASME/ANSI B16.5 and B16.47 Class 150 series A.

Main dimensions are only for information. Contact Stafsjö for certified drawings.



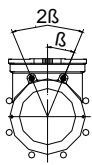

DN 80 - DN 200

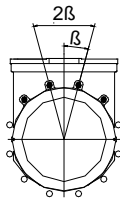

DN 250 - DN 300

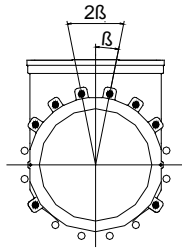

DN 350 - DN 400

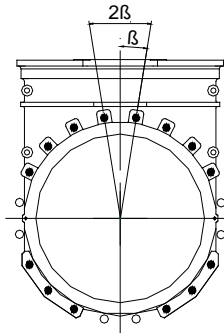

DN 500 - DN 600

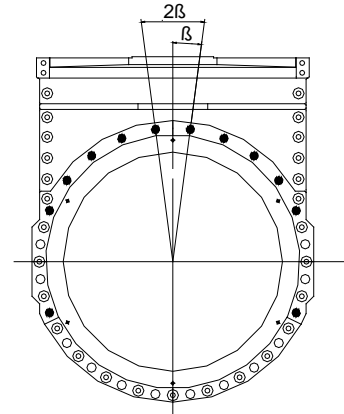

DN 700 - DN 800

## Flange drilling according to EN 1092 PN 10

Flange drilling information for valve with semi lugged valve body (mm)

Size	80	100	125	150	200	250	300	350	400	500	600	700	800
Outside flange diameter	200	220	250	285	340	395	445	505	565	670	780	895	1015
Bolt circle diameter	160	180	210	240	295	350	400	460	515	620	725	840	950
Number of throughgoing bolts (°)	6	6	6	6	6	6	8	8	8	6	6	12	12
Number of tapped holes on each side (•)	2	2	2	2	2	4	4	8	8	14	14	12	12
Bolt size	M16	M16	M16	M20	M20	M20	M20	M20	M24	M24	M27	M27	M30
β°	22,5	22,5	22,5	22,5	22,5	15	15	11,25	11,25	9	9	7,5	7,5
Screw lengths <sup>12)</sup>	10	12	14	12	13	15	19	19	21	27	27	31	31

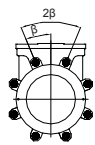

DN 80 - DN 200

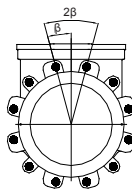

DN 250 - DN 300

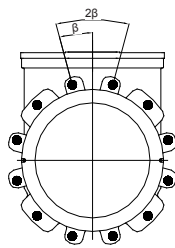

DN 350 - DN 400

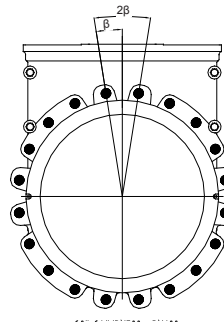

DN 500 - DN 600

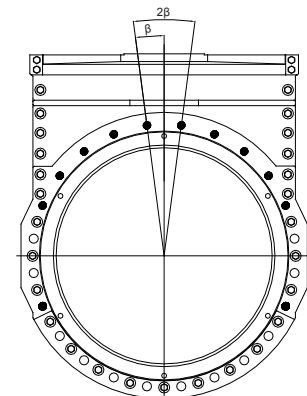

DN 700 - DN 800

## Flange drilling according to EN 1092 PN 10

Flange drilling information for valve with fully lugged valve body (mm)

Size	80	100	125	150	200	250	300	350	400	500	600	700	800
Outside flange diameter	200	220	250	285	340	395	445	505	565	670	780	895	1015
Bolt circle diameter	160	180	210	240	295	350	400	460	515	620	725	840	950
Number of throughgoing bolts (°)	-	-	-	-	-	-	-	-	-	-	-	-	12
Number of tapped holes on each side (•)	8	8	8	8	8	12	12	16	16	20	20	12	12
Bolt size	M16	M16	M16	M20	M20	M20	M20	M20	M24	M24	M27	M27	M30
β°	22,5	22,5	22,5	22,5	22,5	15	15	11,25	11,25	9	9	7,5	7,5
Screw lengths <sup>12)</sup>	13	14	14	14	15	17	21	21	24	32	29	34	34

<sup>12)</sup> Add the value with the thickness of the pipe flanges, the washers and the estimated thickness of the gasket.

° Throughgoing holes

• Tapped holes

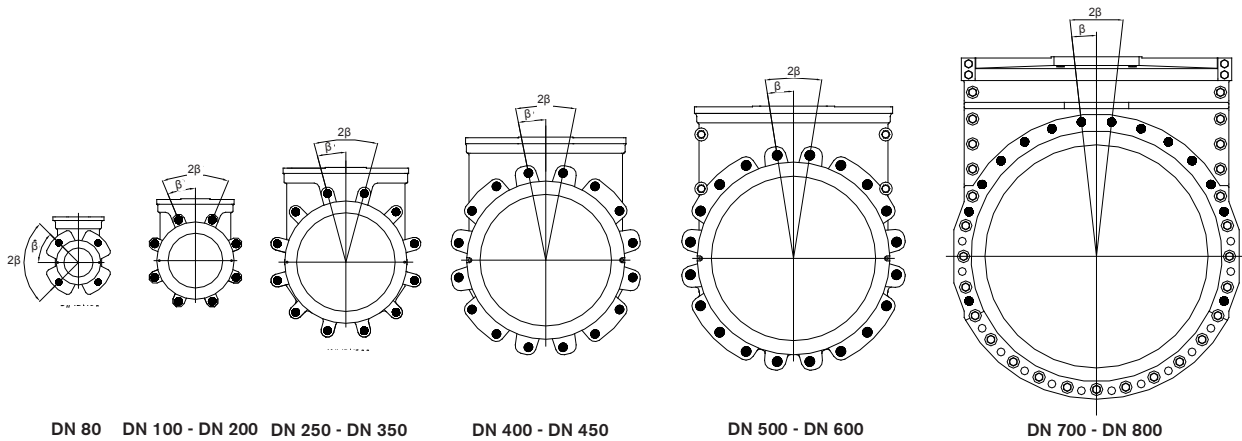

## Flange drilling according to ASME/ANSI B16.5 and B16.47 Class 150 series A

Flange drilling information for valve with fully lugged valve body (mm)

Size	80	100	125	150	200	250	300	350	400	450	500	600	700	800
Outside flange diameter	190,5	228,6	254	279,4	342,9	406,4	482,6	533	597	635	699	813	927	1060
Bolt circle diameter	152,4	190,5	215,9	241,3	298,5	362	431,8	476	540	578	635	749	863	978
Number of throughgoing bolts (◦)	-	-	-	-	-	-	-	-	-	-	-	-	14	14
Number of tapped holes on each side (●)	4	8	8	8	8	12	12	12	16	16	20	20	14	14
Bolt size (UNC)	5/8-11	5/8-11	3/4-10	3/4-10	3/4-10	7/8-9	7/8-9	1-8	1-8	11/8-7	11/8-7	11/4-7	11/4-7	11/2-6
β°	45	22,5	22,5	22,5	22,5	15	15	15	11,25	11,25	9	9	6,5	6,5
Screw lengths <sup>12)</sup>	13	14	14	14	20	17	21	21	24	23	32	29	34	34

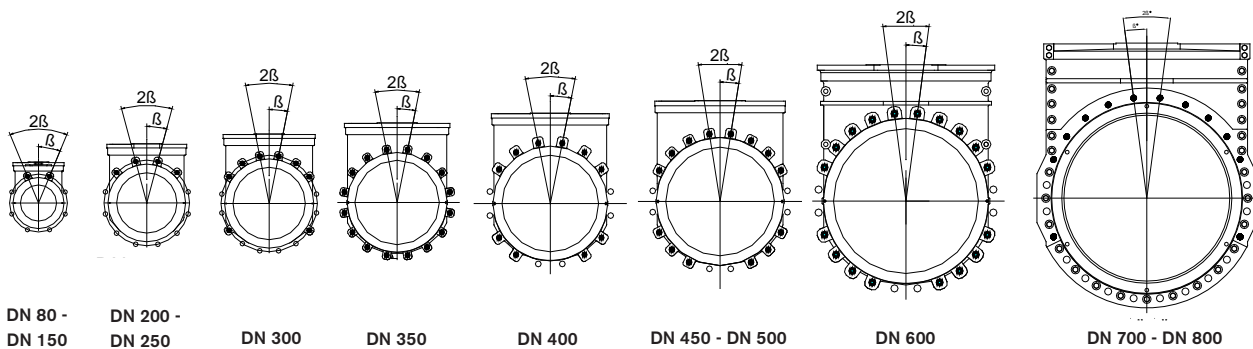

## Flange drilling according to JIS B 2238 10K

Flange drilling information for valve with semi lugged valve body (mm)

DN	80	100	125	150	200	250	300	350	400	450	500	600	700	800
Outside flange diameter	185	210	250	280	330	400	445	490	550	620	675	795	895	1015
Bolt circle diameter	150	175	210	240	290	355	400	445	510	565	620	730	840	950
Number of throughgoing bolts (◦)	6	6	6	6	8	8	8	-	6	6	6	6	12	12
Number of tapped holes on each side (●)	2	2	2	2	4	4	8	16	10	14	14	18	12	12
Bolt size	M16	M16	M20	M20	M20	M22	M22	M22	M24	M24	M24	M30	M30	M30
β°	22,5	22,5	22,5	22,5	15	15	11,25	11,25	11,25	9	9	7,5	7,5	7,5
Screw lengths <sup>12)</sup>	11	12	15	13	13	16	20	20	22	22	24	24	31	31

<sup>12)</sup> Add the value with the thickness of the pipe flanges, the washers and the estimated thickness of the gasket.

◦ Throughgoing holes

● Tapped holes

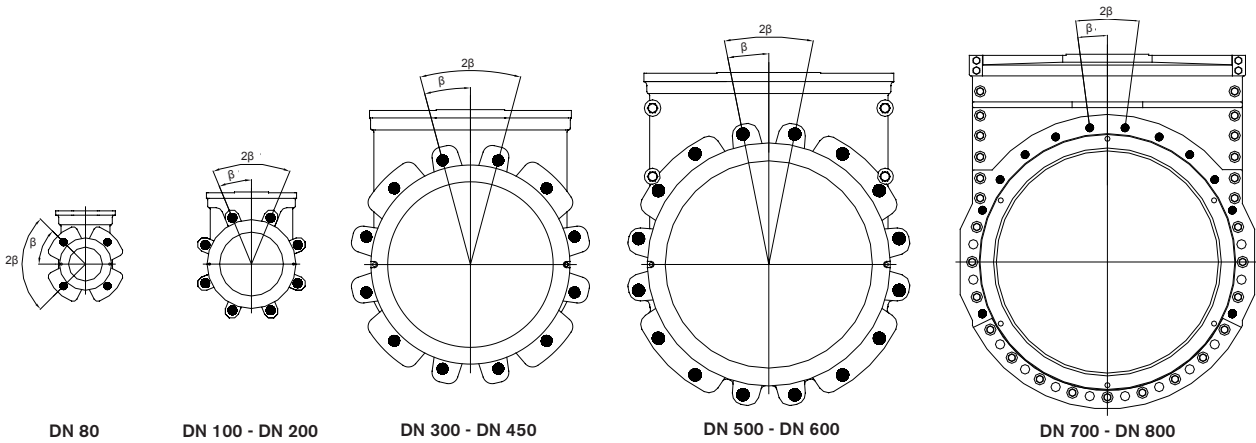

## Flange drilling according to AS Table D

Flange drilling information for valve with fully lugged valve body (mm)													
Size	80	100	150	200	250	300	350	400	450	500	600	700	800
Outside flange diameter	185	215	280	335	405	455	525	580	640	705	825	910	1060
Bolt circle diameter	146	178	235	292	356	406	470	521	584	641	756	845	984
Number of throughgoing bolts (°)	-	-	-	-	-	-	-	-	-	-	-	10	10
Number of tapped holes on each side (•)	4	4	8	8	8	12	12	12	12	16	16	10	10
Bolt size	M16	M16	M16	M16	M20	M20	M24	M24	M24	M24	M27	M30	M33
β°	45	45	22,5	22,5	22,5	15	15	15	15	11,25	11,25	9	9
Screw lengths <sup>12)</sup>	13	14	14	15	17	21	21	21	23	32	29	34	34

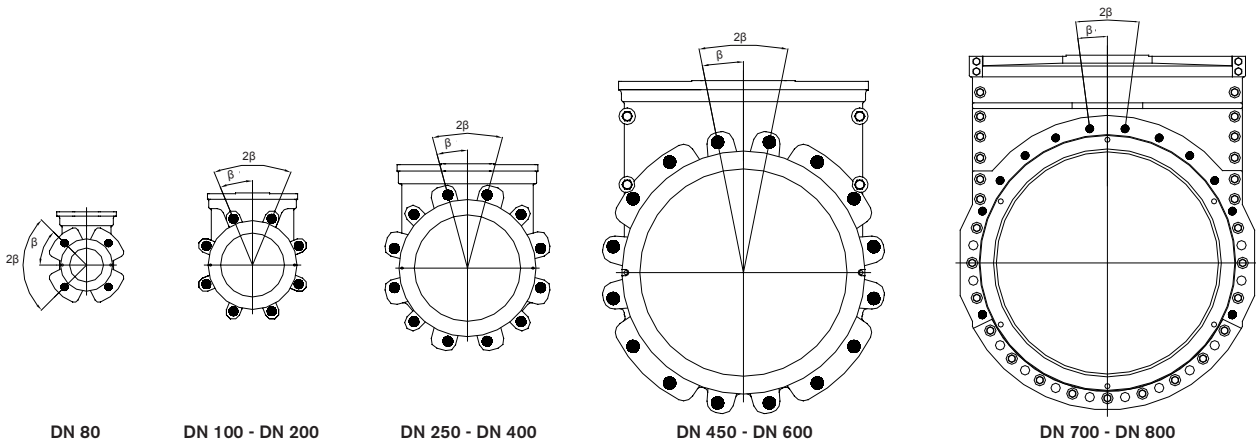

## Flange drilling according to AS Table E

Flange drilling information for valve with fully lugged valve body (mm)													
Size	80	100	150	200	250	300	350	400	450	500	600	700	800
Outside flange diameter	185	215	280	335	405	455	525	580	640	705	825	910	1060
Bolt circle diameter	146	178	235	292	356	406	470	521	584	641	756	845	984
Number of throughgoing bolts (°)	-	-	-	-	-	-	-	-	-	-	-	10	10
Number of tapped holes on each side (•)	4	8	8	8	12	12	12	12	16	16	16	10	10
Bolt size	M16	M16	M20	M20	M20	M24	M24	M24	M24	M24	M30	M30	M33
β°	45	22,5	22,5	22,5	15	15	15	15	11,25	11,25	11,25	9	9
Screw lengths <sup>12)</sup>	13	14	14	15	17	21	21	24	23	32	29	34	34

<sup>12)</sup> Add the value with the thickness of the pipe flanges, the washers and the estimated thickness of the gasket.

° Throughgoing holes

• Tapped holes

Further information is available on [www.stafsjo.com](http://www.stafsjo.com)



## Globally active. Locally represented.

AFRICA South Africa: Valve & Automation (Pty) Ltd, ASIA China: EBRO ARMATUREN (BEIJING) CO., LTD, India: Ebro Armaturen India Pvt. Ltd, Indonesia: Contromatic Prima Mandiri PT, Japan: SKC Co. Ltd, Malaysia: Precision Control SdnBnd, Philippines: EBRO ARMATUREN (PHILIPPINES) INC., Thailand: EBRO VALVES (Trading) Co. Ltd., Vietnam: EBRO VALVES (Thailand) Co., Ltd, AUSTRALIA WITH OCEANIA Australia: EBRO ARMATUREN Pacific PTY. LTD, New Zealand: H.J.Asmuss&Co.Ltd, EUROPE Austria: EBRO ARMATUREN GmbH, Belgium: V.C.T. - Valve & Connector Technology n.v., Denmark: Valtor Industri A/S, Finland: Tecalemit Flow Oy, France: EBRO ARMATUREN and GL&V, Germany: EBRO ARMATUREN Gebr. Bröer GmbH, Great Britain: EBRO Valves Ltd, Hungary: EBRO ARMATUREN Kft, Ireland: Induchem Components Ltd, Iceland: Héðinn HF, Italy: EBRO VALVOLE SRL, The Netherlands: EBRO VALVES B.V., Norway: BAGGES AS, Poland: EBRO ARMATUREN GmbH, Portugal: AxFlow Comércio de Equipamentos LDA, RUSSIA/BELARUS/UKRAINE: EBRO ARMATUREN and LesBumMash Ltd, Spain: EBRO ARMATUREN ESPAÑA, S.L., Switzerland: EBRO Armaturen Est. & Co. KG, Sweden: Stafsjö Valves AB and Ahlsell, Turkey: EBRO ARMATUREN Otomasyon Sistemleri San ve Tic Ltd. Sti NORTH & SOUTH AMERICA Argentina: ESCO ARGENTINA SA, Brazil: Ebro Stafsjö Valves do Brasil LTD, Canada: Armour Valve Ltd, Chile: Ebro Stafsjö Valves Chile Ltd, USA: EBRO ARMATUREN USA Inc., For other countries, please contact us directly.

