

Valve Model Number Description

Every MAXON Series 8000 Valve can be accurately identified by the model number shown on the valve nameplate. The example below shows a typical Series 8000 Valve model number, along with the available choices for each item represented in the model number. The first five choices determine the valve's configured item number. Valve body and actuator options are identified by the next eight characters in the model number.

Configured Item Number					Valve Body				Actuator					
Valve Size	Flow Capacity	Pressure Rating	Normal Position	Area Classification	Body Connection	Body Seals & Bumper	Body Material	Internal Trim Package	Primary Voltage	Switch Option	Enclosure Rating	Instruction Language		
300	C	81	1	1	-	A	A	1	1	-	B	1	A	1

Valve Size

075 – 3/4" (DN 20)
100 – 1" (DN 25)
125 – 1-1/4" (DN 32)
150 – 1-1/2" (DN 40)
200 – 2" (DN 50)
250 – 2-1/2" (DN 65)
300 – 3" (DN 80)
400 – 4" (DN 100)
600 – 6" (DN 150)

Flow Capacity

S – Standard
C – CP Body Construction

Operating Pressure Rating

80 – Pneumatic Standard Pressure
81 – Pneumatic High Pressure

Normal Position

1 – Normally-Closed Shut-Off Valve
2 – Normally-Open Vent Valve

Area Classification

1 – General Purpose
2 – Non-incendive, Class I, II and III Division 2
3 – Intrinsically Safe, Class I, II and III Division 1 (and ATEX Zone 1/21 when ordered with the ATEX IS solenoid) [1]
4 – Valve Body Only

Body Connection

A – NPT
B – ANSI Flanged (ISO 7005 PN 20)
C – ISO 7-1 Threaded
D – DIN PN 16 Flanged
E – Socket Welded Nipple
F – Socket Welded Nipple w/Class 150 Flange (ISO 7005 PN 20)
G – Socket Welded Nipple w/Class 300 Flanges (ISO 7005 PN 50)
H – EN1092-1 PN16 (ISO 7005-1 PN16)
* - Actuator Only

Body Seals & Bumper

A – Buna N
B – Viton
C – Ethylene Propylene [2]
F – Omniflex
X – Special
* - Actuator Only

Body Material

1 – Cast Iron
2 – Carbon Steel
5 – Stainless Steel
6 – Low Temp Carbon Steel
X – Special
* - Actuator Only

Internal Trim Package

1 – Trim Package 1
2 – Trim Package 2
3 – Trim Package 3 (NACE)
4 – Trim Package 2, oxy clean [2]
5 – Trim Package 3, oxy clean [2]
X – Special [2]
* - Actuator Only

Primary Voltage

A – 120VAC 50Hz
B – 120VAC 60Hz
D – 240VAC 50Hz
E – 240VAC 60Hz
G – 24VDC
H – 24VDC IS [1]
J – 24VDC IS-ATEX [1]
X – Special
* - Valve Body Only

Switch Option

0 – None
1 – VOS1/VCS1 - V7
2 – VOS2/VCS2 - V7
3 – VOS1/VCS1 - IP67
4 – VOS2/VCS2 - IP67
X – Special
* - Valve Body Only

Enclosure Rating

A – NEMA 4, IP65
B – NEMA 4X, IP65
X – Special
* - Valve Body Only

Instruction Language

0 – English
1 – French
2 – Russian
3 – German

[1] 122°F maximum ambient temperature limit

[2] 0°F minimum ambient temperature limit

Valve Body Assembly Options & Specifications

Series 8000 Normally-Closed Shut-Off Valves									
Nominal Pipe Size	Flow Capacity	Actuator Pressure Class	Body Connections Available	Body Material	Trim Package Options	Cv Rating	MOPD Rating (psig)		
.75"	Std.	High Press.	A, C	1, Cast Iron	1, 2, 3, 4, 5	19	200		
1"	Std.	High Press.	A, C	1, Cast Iron	1, 2, 3, 4, 5	20	200		
			A, C, E, F, G	2, 6 Carbon Steel 5, Stainless Steel			255		
1.25"	Std.	High Press.	A, C	1, Cast Iron	1, 2, 3, 4, 5	45	200		
1.5"	Std.	High Press.	A, C	1, Cast Iron	1, 2, 3, 4, 5	53	200		
			A, C, E, F, G	2, 6 Carbon Steel 5, Stainless Steel			255		
2"	Std.	High Press.	A, B, C, D, H	1, Cast Iron	1, 2, 3, 4, 5	86	200		
			A, C, E, F, G	2, 6 Carbon Steel 5, Stainless Steel			255		
2.5"	Std.	High Press.	A, B, C, D	1, Cast Iron	1	127	150		
			A, B, C, D	1, Cast Iron			1, 2, 3, 4, 5	304	
	Std.	High Press.	B, D, H	2, 6 Carbon Steel 5, Stainless Steel	50				
			B, D, H	2, 6 Carbon Steel 5, Stainless Steel	175				
	CP	High Press.	A, B, C, D, H	1, Cast Iron	1, 2, 3, 4, 5	304			175
			B, D, H	2, 6 Carbon Steel 5, Stainless Steel					
3"	Std.	High Press.	A, C	1, Cast Iron	1	173	150		
			A, B, C, D, H	1, Cast Iron			1, 2, 3, 4, 5	423	
	Std.	High Press.	B, D, H	2, 6 Carbon Steel 5, Stainless Steel	40				
			B, D, H	2, 6 Carbon Steel 5, Stainless Steel	135				
	CP	High Press.	A, B, C, D, H	1, Cast Iron	1, 2, 3, 4, 5	423			135
			B, D, H	2, 6 Carbon Steel 5, Stainless Steel					
4"	CP	Std.	B, D, H	1, Cast Iron	1, 2, 3, 4, 5	490	40		
				2, 6 Carbon Steel 5, Stainless Steel			135		
	High Press.	1, Cast Iron		1, 2, 3, 4, 5				490	
		2, 6 Carbon Steel 5, Stainless Steel							
6"	Std.	Std.	B, D, H	1, Cast Iron	1, 2, 3, 4, 5	1172	60		
				2, 6 Carbon Steel 5, Stainless Steel			100		
	High Press.	Std.		1, Cast Iron				1, 2, 3, 4, 5	1172
				2, 6 Carbon Steel 5, Stainless Steel					

Body Connections:

- A - NPT
- B - ANSI Flanged (ISO 7005 PN20)
- C - ISO 7-1 Threaded
- D - DIN PN16 Flanged
- E - Socket Welded Nipple
- F - Socket Welded Nipple w/ Class 150 Flange (ISO 7005 PN20)
- G - Socket Welded Nipple w/ Class 300 Flange (ISO 7005 PN50)
- H - EN1092-1 PN16 (ISO 7005-1 PN16)

Body Material:

- 1 - Cast Iron
- 2 - Carbon Steel
- 5 - Stainless Steel
- 6 - Low Temp Carbon Steel

Trim Package Options and Typical Material:

- 1 - 400 Series Stainless Steel Seat, Hardened Ductile Iron Disc, PEEK Follower Ring
- 2 - 300 Series Stainless Steel Seat, 300 Series Stainless Steel Disc, PEEK Follower Ring
- 3 - 300 Series Stainless Steel Seat, 300 Series Stainless Steel Disc, 300 Series Stainless Steel Stem, PEEK Follower Ring (NACE compliant)
- 4 - Oxy Clean, Trim 2
- 5 - Oxy Clean, Trim 3

Body Seals and Bumper:

All configurations allow for Buna-N and Viton elastomers as standard. Omniflex and Ethylene Propylene are available for special services. Consult MAXON for proper application.

Valve Body Assembly Options & Accessories

Series 8000 Normally-Open Vent Valves							
Nominal Pipe Size	Flow Capacity	Actuator Pressure Class	Body Connections Available	Body Material	Trim Package Options	Cv Rating	MOPD Rating (psig)
.75"	Std.	High Press.	A, C	1, Cast Iron	1, 2, 3, 4, 5	19	200
1"	Std.	High Press.	A, C	1, Cast Iron	1, 2, 3, 4, 5	20	200
			A, C, E, F, G	2, 6 Carbon Steel 5, Stainless Steel			255
1.5"	Std.	High Press.	A, C	1, Cast Iron	1, 2, 3, 4, 5	53	200
			A, C, E, F, G	2, 6 Carbon Steel 5, Stainless Steel			255
2"	Std.	High Press.	A, B, C, D, H	1, Cast Iron	1, 2, 3, 4, 5	86	200
			A, C, E, F, G	2, 6 Carbon Steel 5, Stainless Steel			255
2.5"	CP	Std.	A, B, C, D	1, Cast Iron	1, 2, 3, 4, 5	304	50
			B, D, H	2, 6 Carbon Steel 5, Stainless Steel			175
		High Press.	A, B, C, D, H	1, Cast Iron			
			B, D, H	2, 6 Carbon Steel 5, Stainless Steel			
3"	CP	Std.	A, B, C, D, H	1, Cast Iron	1, 2, 3, 4, 5	423	40
			B, D, H	2, 6 Carbon Steel 5, Stainless Steel			135
		High Press.	A, B, C, D, H	1, Cast Iron			
			B, D, H	2, 6 Carbon Steel 5, Stainless Steel			
4"	CP	Std.	B, D, H	1, Cast Iron	1, 2, 3, 4, 5	490	40
				2, 6 Carbon Steel 5, Stainless Steel			135
		High Press.		1, Cast Iron			
				2, 6 Carbon Steel 5, Stainless Steel			

Body Connections:

A - NPT
B - ANSI Flanged (ISO 7005 PN20)
C - ISO 7-1 Threaded
D - DIN PN16 Flanged
E - Socket Welded Nipple
F - Socket Welded Nipple w/ Class 150 Flange (ISO 7005 PN20)
G - Socket Welded Nipple w/ Class 300 Flange (ISO 7005 PN50)
H - EN1092-1 PN16 (ISO 7005-1 PN16)

Body Material:

1 - Cast Iron
2 - Carbon Steel
5 - Stainless Steel
6 - Low Temp Carbon Steel

Trim Package Options and Typical Material:

1 - 400 Series Stainless Steel Seat, Hardened Ductile Iron Disc, PEEK Follower Ring
2 - 300 Series Stainless Steel Seat, 300 Series Stainless Steel Disc, PEEK Follower Ring
3 - 300 Series Stainless Steel Seat, 300 Series Stainless Steel Disc, 300 Series Stainless Steel Stem, PEEK Follower Ring (NACE compliant)
4 - Oxy Clean, Trim 2
5 - Oxy Clean, Trim 3

Body Seals and Bumper:

All configurations allow for Buna-N and Viton elastomers as standard. Omniflex and Ethylene Propylene are available for special services. Consult MAXON for proper application.

Valve Body Assembly Specifications

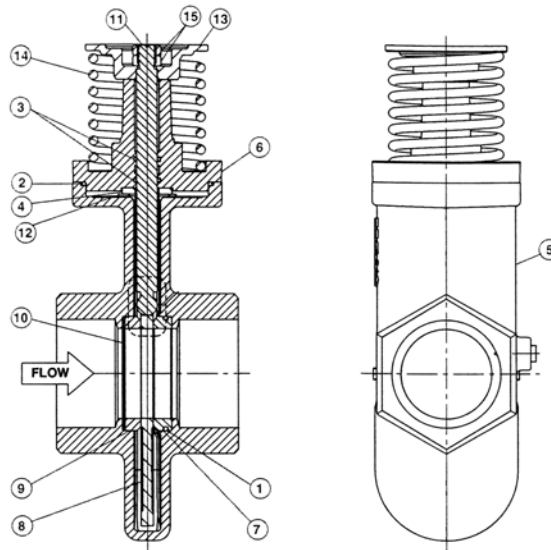

Body Seals and Bumper Material

Item No.	Description	Material
1	Seat O-Ring	Standard material options are Buna-N and Viton. Omniflex and Ethylene Propylene are available for special service. Consult MAXON for proper material selection.
2	Body O-Ring	
3	Stem O-Ring	
4	Bumper	

Body and Bonnet Materials

Item No.	Description	Material Code			
		1	2	5	6
5	Body	Cast Iron	Carbon Steel	Stainless Steel	Low Temp Carbon Steel
6	Bonnet	ASTM A126, Class B	ASTM A216 Gr. WCB	ASTM A351 Gr. CF8M	ASTM A352 Gr. LCB

Trim Package Materials

Item No.	Description	Internal Trim Package		
		1	2	3
7	Seat	Hardened 400 Series Stainless Steel	300 Series Stainless Steel	300 Series Stainless Steel
8	Disc	Hardened Ductile Iron	300 Series Stainless Steel	300 Series Stainless Steel
9	Follower Ring	PEEK	PEEK	PEEK
10	Wavy Spring	300 Series Stainless Steel		
11	Stem	17-4 PH Stainless Steel		300 Series Stainless Steel
12	Striker Plate	300 Series Stainless Steel		
13	Spring Retainer	Blackened Carbon Steel		
14	Compression Spring	17-7 PH Stainless Steel		
15	Jam Nut	Zinc Plated Carbon Steel		
16	Spring Pin (when req'd)	Carbon Steel	400 Series Stainless Steel	18-8 Stainless Steel

Valve Body Assembly - Gas Compatibility

Gas	Gas Code	Suggested Material Options			MOPD Rating	Agency Approvals and Certifications			
		Body Seals & Bumper	Body & Bonnet	Trim Package		FM	CSA [3]	CE [4]	
								GAD	MD
Air	AIR	A, B, C, F	1, 2, 5, 6	1, 2, 3	Std.	X	X	NA	X
Ammonia	AMM	C	1, 2, 5, 6	1, 2, 3	Std.	X	X	NA	X
Butane Gas	BUT	A, B, F	1, 2, 5, 6	1, 2, 3	Std.	X	X	X	X
Coke Oven Gas	COKE	B, F	5	Analysis Required	Std.	X	X	NA	X
Delco	DEL	A, B, F	1, 2, 5, 6	1, 2, 3	Std.	X	X	NA	X
Digester [1]	DIG	Analysis Required	5	Analysis Required	Std.	X	X	NA	X
Endothermic AGA	ENDO	A, B, F	1, 2, 5, 6	1, 2, 3	Std.	X	X	NA	X
Exothermic Gas	EXO	A, B, F	1, 2, 5, 6	1, 2, 3	Std.	X	X	NA	X
Hydrogen Gas	HYD	A, B, C, F	2, 5, 6	2, 3	[2]	X	X	NA	X
Manufactured [1]	MFGD	Analysis Required	5	Analysis Required	Std.	X	X	NA	X
Natural Gas	NAT	A, B, F	1, 2, 5, 6	1, 2	Std.	X	X	X	X
Nitrogen	NIT	A, B, C, F	1, 2, 5, 6	1, 2	Std.	X	X	NA	X
Oxygen High	OXYH	B, C, F	2, 5, 6	4, 5	200 psig max	X	X	NA	X
Oxygen Low	OXYL	B, C, F	1, 2, 5, 6	4, 5	30 psig max	X	X	NA	X
Oxygen X	OXYX	B, C, F	2, 5, 6	4, 5	Std.	X	X	NA	X
Propane	PROP	A, B, F	1, 2, 5, 6	1, 2, 3	Std.	X	X	X	X
Refinery [1]	REF	Analysis Required	5	Analysis Required	Std.	X	X	NA	X
Sour Natural[1]	SOUR	Analysis Required	5	Analysis Required	Std.	X	X	NA	X
Town Gas [1]	TOWN	Analysis Required	5	Analysis Required	Std.	X	X	X	X
Land Fill Gas	LAND	Analysis Required	5	Analysis Required	Std.	X	X	NA	X

Notes:

[1] Other body and trim packages may be acceptable pending fuel analysis. For pricing inquiry, Viton body seals and bumper material will be standard option. Contact MAXON for details.

[2] Valve maximum operating pressure (MOPD) to be reduced by 25% from standard ratings.

[3] ISO connections are not recognized by CSA standards.

[4] All 8000 Valves do meet the essential requirements of the Low Voltage (73/23/EC) and the EMC (89/336/EC) Directives. GAD refers to the Gas Appliances Directive (90/396/EC): this Directive only covers the use of commercially available fuels (natural gas, butane, town gas and LPG). MD stands for Machinery Directive (98/37/EC).

Body Seals & Bumper:

A - Buna N

B - Viton

C - Ethylene Propylene

F - Omniflex o-rings/Viton bumper

Body & Bonnet:

1 - Cast Iron

2 - Carbon Steel

5 - Stainless Steel

6 - Low Temp Carbon Steel

Trim Package:

1 - Trim Package 1

2 - Trim Package 2

3 - Trim Package 3 (NACE)

4 - Trim Package 2, Oxy Clean

5 - Trim Package 3, Oxy Clean

Valve Actuator Assembly Specifications

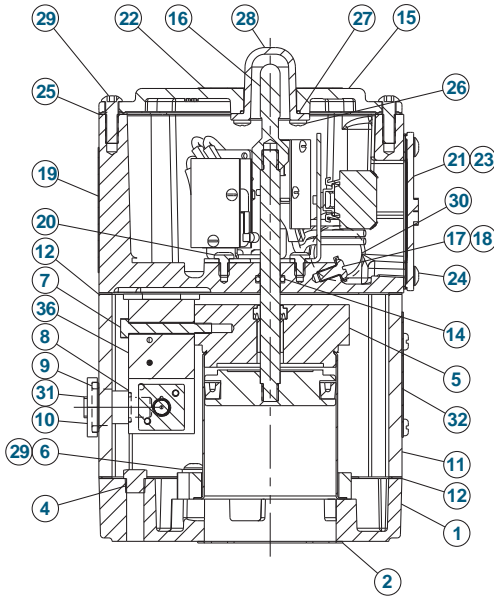

Typical Actuator Assembly

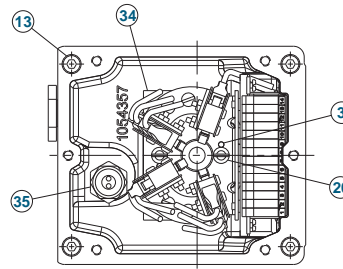

View Without Top Plate

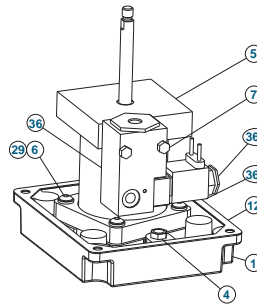

Typical Cylinder Assembly Mounting

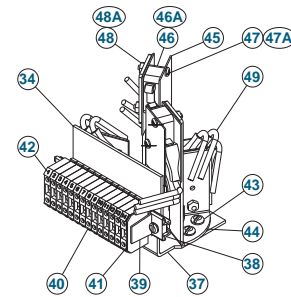

General Purpose Switch Assembly

Item Number	Description	Item No.	Description
1	Base Plate	28	Indicator Cover
2	Bonnet Gasket	29	M6-1.0 x 20 Cap Screw
3	Drive Pin	30	3/4" Pipe Plug
4	Filter Vent	31	.125 Inlet Pipe Plug
5	Cylinder Assembly	32	Info Plate
6	M6 Lock Washer	33	Actuator Bolts (not shown)
7	M5-0.8 x 40 Hex Screw	34	Switch Assembly
8	O-Ring	35	Liquid Tight Connector
9	O-Ring	36	Solenoid w/Quick Exhaust Assembly
10	Solenoid Adapter Inlet	36A	Solenoid Coil
11	Housing	36B	Solenoid Cap
12	Housing Gasket	37	Switch & Terminal Bracket
13	M6-1.0 x 60 Soc HD Cap Screw	38	DIN Rail
14	O-Ring	39	End Stop
15	Top Plate	40	Terminal Block
16	Indicator	41	End Cover
17	Washer	42	Marker Strips
18	M5-0.8 x 10 Ground Screw	43	M4-0.7 x 6 Slotted Screw
19	Top Housing	44	Switch Bracket
20	M4-0.7 x 6 Slotted Screw	45	Switch Insulator
21	Terminal Block Cover Gasket	46	V7 Switch
22	Info Label	46A	IP67 Switch
23	Terminal Block Cover	47	#4-40 x .75 Slotted Screw
24	M5-0.8 x 12 Cap Screw	47A	#2-56 x .437 Slotted Screw
25	Top Housing Gasket	48	#4-40 Hex Nut
26	#8-18 x .38 Self-Threading Screw	48A	#2-56 Hex Nut
27	O-Ring	49	Wire

Electrical Data

General

Series 8000 Valves are pneumatically operated and a solenoid valve controls the air supply. The solenoid valve is directly wired into the control system.

Position switch wiring diagrams (reproduced below) are part of each valve assembly, summarizing electrical data and wiring for a valve equipped with terminal block and a full complement of optional switches.

Good practice normally dictates that auxiliary switches in valves should be used for signal duty only, not to operate additional safety devices.

Valve position switches are offered in SPDT (Single Pole/Double Throw). Recommended packages include one open switch and one closed switch, (VOS1/VCS1) and additional auxiliary switches designated by VOS2/VCS2.

VCS (Valve Closed Switch) is actuated at the end of the closing stroke.

VOS (Valve Open Switch) is actuated at the end of the opening stroke.

Switch amperage ratings are shown on the schematic wiring diagrams below. **DO NOT EXCEED** rated amperage or total load shown. Diagrams show valve with a full complement of switches. The indicated internal wiring is present only when the appropriate auxiliary switches are specified.

Figure 1: Normally-Closed Shut-Off Valve

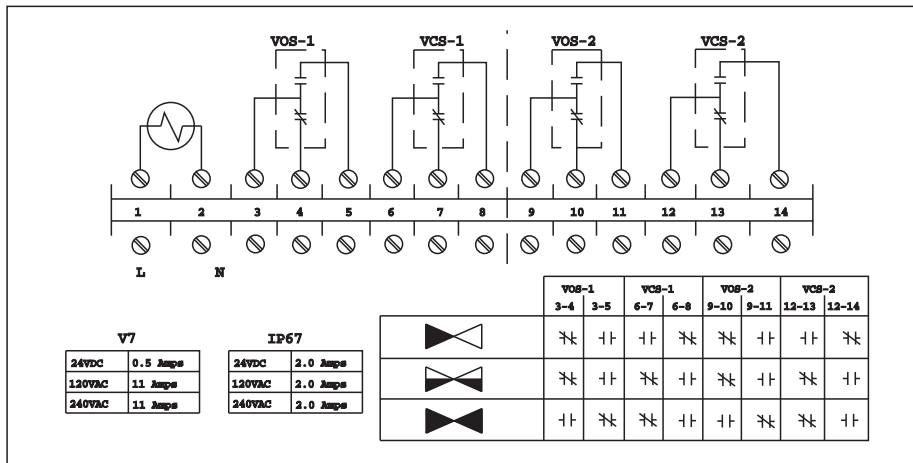
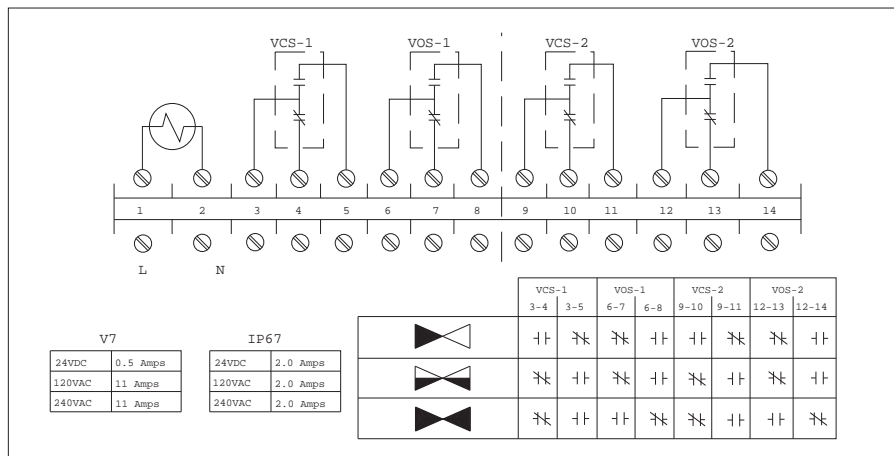

Figure 2: Normally-Open Vent Valve



Electrical Data

General Purpose - Series 8011, 8111, 8021 & 8121

Solenoid valve power ratings				
Voltage	Amperage (A)		Power	
	In-Rush	Holding	In-Rush	Holding
24VDC	0.20	0.20	4.8 W	4.8 W
120VAC 50 Hz	0.09	0.07	11 VA	8.5 VA
120VAC 60 Hz	0.08	0.05	9.4 VA	6.9 VA
240VAC 50 Hz	0.05	0.04	11 VA	8.5 VA
240VAC 60 Hz	0.04	0.03	9.4 VA	6.9 VA

Standard switch amperage ratings as shown on the valve switch wiring diagram	
Voltage	Maximum Amperage (A)
24VDC	0.5
120VAC 50/60 Hz	11
240VAC 50/60 Hz	11

Non-incendive Valves - Series 8012, 8112, 8022 & 8122

Solenoid valve power ratings				
Voltage	Amperage (A)		Power	
	In-Rush	Holding	In-Rush	Holding
24VDC	0.20	0.20	4.8 W	4.8 W
120VAC 50 Hz	0.09	0.07	11 VA	8.5 VA
120VAC 60 Hz	0.08	0.05	9.4 VA	6.9 VA
240VAC 50 Hz	0.05	0.04	11 VA	8.5 VA
240VAC 60 Hz	0.04	0.03	9.4 VA	6.9 VA
24VDC IS	.09	.09	2.1 W	2.1 W

IP67 switch amperage ratings as shown on the valve switch wiring diagram	
Voltage	Maximum Amperage (A)
24VDC	2.0
120VAC 50/60 Hz	2.0
240VAC 50/60 Hz	2.0

Intrinsically Safe Valves - Series 8033 & 8133

The Series 8000 Valve achieves Class I Div.1 hazardous location certification through the Intrinsically Safe (IS) protection method. Below is a representation of the Control Drawing. The MAXON standard offering does not include the barriers/isolators that are depicted below in the non-hazardous location; however, they can be provided as an additional accessory. Consult MAXON for details.

The intrinsic safety and operational criteria for most applications can be met with a 24 VDC supply and the barriers described in the Control Drawing. Specific installations with long cable runs, low power requirements, or other complications may require a barrier with different parameters.

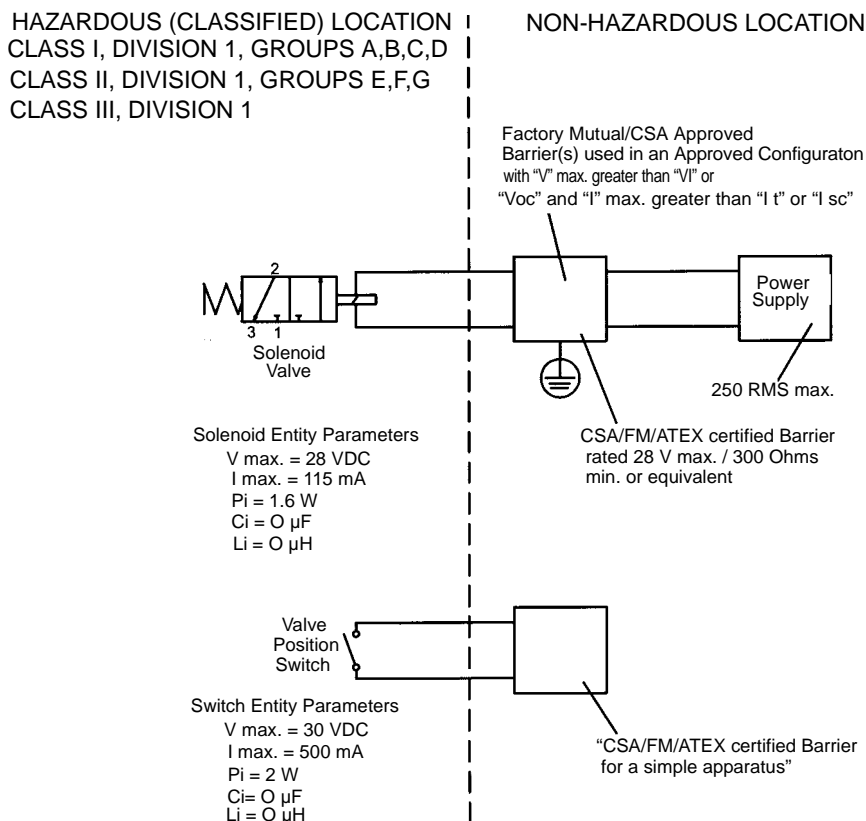

NOTES:

- 1) The Intrinsic Safety Entity concept allows the interconnection of two FM approved (CSA Certified when installed in Canada) Intrinsically safe devices with entity parameters not specifically examined in combination as a system when:
 V_{oc} or U_o or $V_t \leq V_{max}$, I_{sc} or I_o or $I_t \leq I_{max}$, C_a or $C_o \geq C_i + C_{cable}$, L_a or $L_o \geq L_i + L_{cable}$, and for FM only: $P_o \leq P_i$.
- 2) Dust-tight conduit seal must be used when installed in Class II and Class III environments.
- 3) Control equipment connected to the Associated Apparatus must not use or generate more than 250 Vrms or Vdc.
- 4) Installation in the U.S. should be in accordance with ANSI/ISA RP12.06.01 "Installation of Intrinsically Safe Systems for Hazardous (Classified) Locations" and the National Electric Code® (ANSI/NFPA 70) Sections 504 and 505.
- 5) Installation in Canada should be in accordance with the Canadian Electrical Code, CSA C22.1, Part 1, Appendix F.
- 6) Installation in the European Union should be in accordance to Directive 94/9/EC (ATEX 95).
- 7) The configuration of associated Apparatus must be FM Approved (CSA Certified when in Canada) under Entity Concept.
- 8) Associated Apparatus manufacturer's installation drawing must be followed when installing this equipment.
- 9) No revision to drawing without prior authorization from FM Approval and CSA International.

To select a different safety barrier, choose a design that limits voltage, current, and power under worst-case fault conditions to values less than the IS entity parameters, while still meeting the minimum operational requirements under worst-case non-fault conditions. The IS entity parameters and operational requirements are listed in the following tables.

The barrier will specify a maximum voltage peak V_{oc}^1 , a maximum short-circuit current, I_{sc}^2 and maximum power output P_o^3 . These barrier ratings must be less than or equal to the IS entity parameters of the field device, i.e., $V_{oc} \leq V_{max}$, $I_{sc} \leq I_{max}$, and $P_o \leq P_i$. The barrier will also specify a maximum allowed capacitance C_a and inductance L_a , which must be greater than or equal to the sum of those of the load device and field wiring, i.e., $C_a \geq C_i + C_{cable}$ and $L_a \geq L_i + L_{cable}$.

The solenoid requires a minimum current (I_{min}) to operate properly. The nominal barrier input voltage ($V_{working}$, as specified by the barrier) must be adequate to provide I_{min} through the maximum barrier resistance, the maximum wiring resistance, the resistance of any fuses, and the maximum solenoid resistance (R_i).



NOTE: $V_{working}$ will always be less than V_{max} or V_{oc} . Never intentionally supply V_{oc} to the barrier, as this could blow an internal fuse and ruin the barrier.

Barrier selection criteria for solenoid

IS entity parameters ⁴	
Maximum voltage input (V_{max})	28 V ⁵
Maximum current input (I_{max})	115 mA
Maximum power input (P_i)	1.6 W
Internal capacitance (C_i)	0 μ F
Internal inductance (L_i)	0 μ H
Operational Parameters	
Minimum operational current (I_{min})	37 mA
Solenoid internal resistance (R_i)	275 ohms \pm 8%

Barrier selection criteria for switch

IS entity parameters (simple apparatus)	
Maximum voltage input (V_{max})	30 V ⁶
Maximum current input (I_{max})	500 mA ⁶
Maximum power input (P_i)	1.3 W ⁷
Internal capacitance (C_i)	0 μ F
Internal inductance (L_i)	0 μ H
Operational Parameters	
Minimum operational current (I_{min})	Application specific
Switch internal on-resistance (R_i)	< 1 ohm

[1] The maximum voltage possible at the barrier input or output under a no-load condition.

[2] Found when the barrier input is at V_{oc} and a short-circuit appears on the barrier output.

[3] Found when the barrier input is at V_{oc} and a matched load appears on the barrier output. Note that this value is the transmitted power, and does not include the power dissipated by the barrier itself.

[4] Obtained from the manufacturer's published entity parameters.

[5] Never intentionally supply V_{max} to the barrier, as this could blow an internal fuse and ruin the barrier.

[6] Obtained from the switch's safety ratings.

[7] Standard P_i for a simple apparatus.

Dimensions & Weights

Series 8100 Valve Bodies: .75" (DN20) to 3" (DN80)

Body Connection A & C

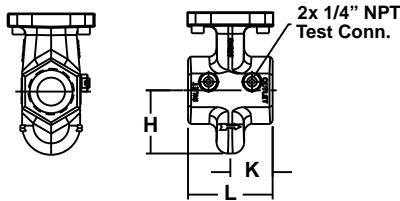

Body Connection B, D & H

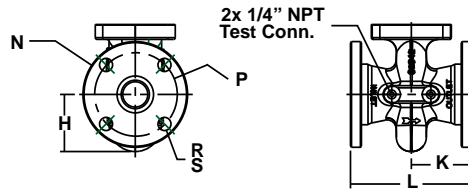

Body Connection E

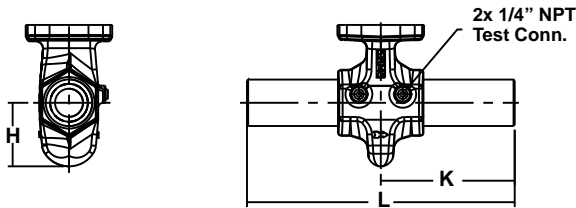

Body Connection F & G

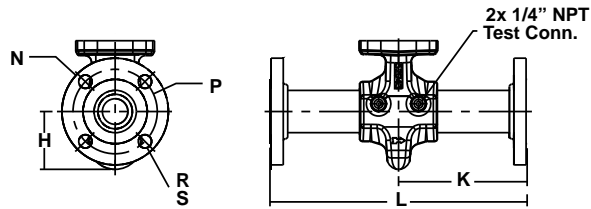

Valve Size	Flow Capacity	Body Connection	Body/Bonnet Material	Approximate Dimensions (in inches)							Approximate Weight (in lbs)		
				H	K	L	N Ø	P Ø	R Ø	S # of holes	Body Assembly	Actuator Assembly	Total Weight
.75"	S	A, C	Cast Iron	2.0	1.9	3.8	N/A				8	12	20
1"	S	A, C	Cast Iron				N/A				8		20
		A, C	Carbon Steel & Stainless Steel	N/A				9	21				
		E		N/A				11	23				
		F		4	4.3	3.1	0.62	15	27				
		G	4.9		3.5	0.75	17	29					
1.25"	S	A, C	Cast Iron	2.4	2.0	4.0	N/A				9		21
1.5"	S	A, C	Carbon Steel & Stainless Steel	N/A				11	23				
		A, C		N/A				11	23				
		E		N/A				14	26				
		F	4	5.0	3.9	0.62	21	33					
		G		6.1	4.5	0.88	26	38					
2"	S	A, C	Cast Iron	2.2	4.4	N/A				16	28		
		B		4	6.0	4.8	0.75	26	38				
		D, H	3.5		7.0	6.5	4.9	0.71	26	38			
		A, C	Carbon Steel & Stainless Steel	2.2	4.4	N/A				18	30		
		E		6.9	13.8	N/A				23	35		
		F		4	6.0	4.8	0.75	33	45				
		G			7.3	14.5	6.5	5.0	0.75	37	49		
		2.5"	S	A, C	Cast Iron	2.9	2.5	5.0	N/A				19
B	4			7.0		5.5	0.75	30	42				
D				3.1		3.8	7.5	7.3	5.7	0.71	30	42	
3"	S	A, C	Cast Iron	3.0	2.6	5.2	N/A				20	32	

Flow Capacity:
S - Standard
C - CP Body Construction

Body Connection:
A - NPT
B - ANSI Flanged (ISO 7005 PN20)
C - ISO 7-1 Threaded

D - DIN PN16 Flanged
E - Socket Welded Nipple
F - Socket Welded Nipple w/ Class150 Flange (ISO 7005 PN20)
G - Socket Welded Nipple w/ Class 300 Flange (ISO 7005 PN50)
H - EN1092-1 PN16 (ISO 7005-1 PN16)

Series 8100 Actuator: .75" (DN20) to 3" (DN80)

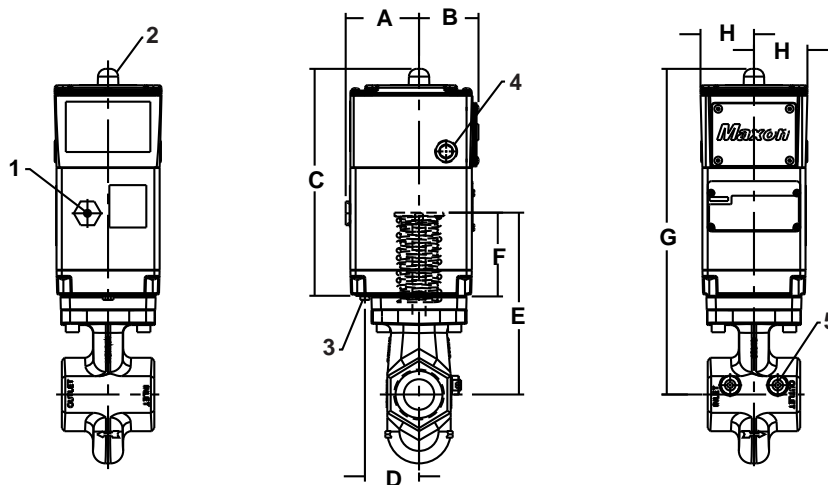

Valve Size	Approximate Dimensions (in inches)							
	A	B	C	D	E	F	G	H
.75"	3.5	2.8	10.7	2.6	7	4.0	14	2.5
1"					8		15	
1.25"					8		15	
1.5"					8		15	
2"					9		16	
2.5"					9		16	
3"								

1	1/8" NPT Air Inlet Connection
2	Visual Indication of Valve Position
3	Air Exhaust "Do Not Block"
4	2x 3/4" Conduit Connection
5	2x 1/4" NPT Test Connection

Series 8000 Valve Body: 2.5" CP (DN65), 3" CP (DN80), 4" CP (DN100)

Body Connection A & C

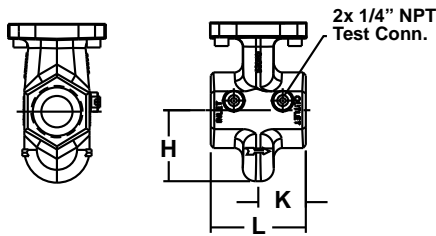

Body Connection B, D & H

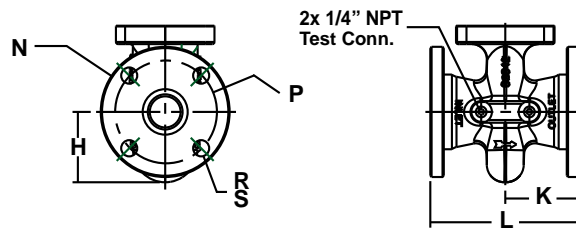

Body Connection E

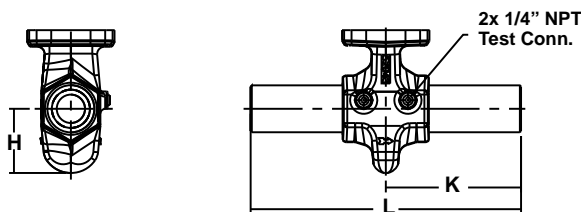

Body Connection F & G

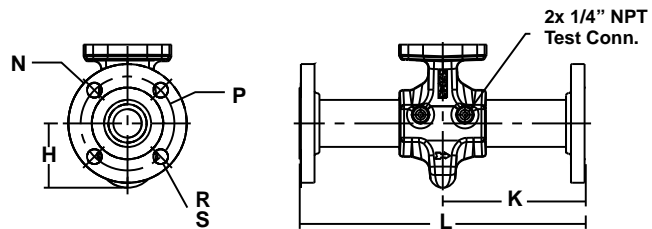

Valve Size	Flow Capacity	Body Connection	Body/Bonnet Material	Approximate Dimensions (in inches)							Approximate Weight (in lbs)		
				H	K	L	N Ø	P Ø	R Ø	S # of holes	Body Assembly	Actuator Assembly	Total Weight
2.5"	C	A, C	Cast Iron	4.3	2.5	5.0	N/A				19	13	32
		B		4.5	3.8	7.5	7.0	5.5	0.75	4	31		44
		D					7.3	5.7	0.75	31	44		
		H					7.3	5.7	0.75	8	31		44
		B	Carbon Steel & Stainless Steel	7.0	5.5	0.75	4	34	47				
		D		7.3	5.7	0.71	34	47					
		H		7.3	5.7	0.71	8	30	43				
C	G	CS & SS	4.4	6.1	12.3	7.5	5.9	0.88	8	39	51		
3"	C	A, C	Cast Iron	5.1	2.8	5.5	N/A				24		37
		B		5.2	4.0	8.0	7.5	6.0	0.75	4	46		59
		D, H					7.9	6.3	0.75	8	46		59
		B	7.5				6.0	0.75	4	47	60		
		D, H	7.9				6.3	0.71	8	47	60		
		C	G	CS & SS	5.2	6.6	13.3	8.3	6.6	0.88	8	56	68
		4"	C	B	Cast Iron	5.5	4.5	9.0	9.0	7.5	0.75	8	64
D, H	8.7			7.1					0.75	64	77		
B	9.0			7.5	0.75				64	77			
D, H	8.7			7.1	0.71				64	77			
C	G			CS & SS	5.1				7.4	15.3	10		7.9

Flow Capacity:
S - Standard
C - CP Body Construction

Body Connection
A - NPT
B - ANSI Flanged (ISO 7005 PN20)
C - ISO 7-1 Threaded
D - DIN PN16 Flanged
E - Socket Welded Nipple
F - Socket Welded Nipple w/ Class 150 Flange (ISO 7005 PN20)
G - Socket Welded Nipple w/ Class 300 Flange (ISO 7005 PN50)
H - EN1092-1 PN16 (ISO 7005-1 PN16)

Series 8000 Actuator: 2.5" CP (DN65), 3" CP (DN80), 4" CP (DN100)

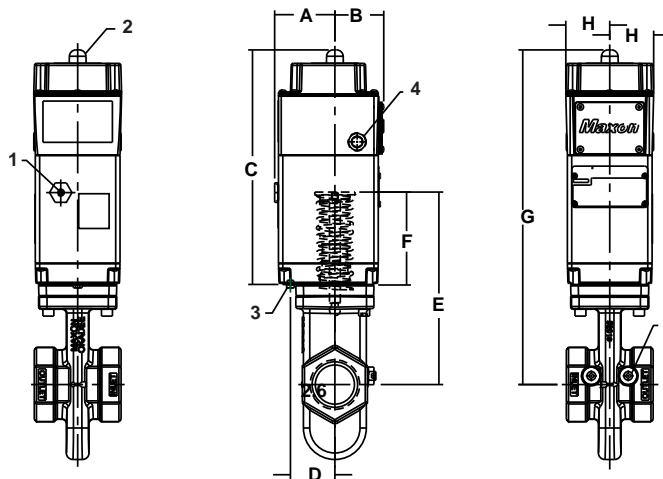

Valve Size	Flow Capacity	Approximate Dimensions (in inches)							
		A	B	C	D	E	F	G	H
2.5"	CP	3.5	2.8	13.5	2.6	11.1	5.3	19.3	2.5
3"	CP					11.8		20	
4"	CP								

1	1/8" NPT Air Inlet Connection
2	Visual Indication of Valve Position
3	Air Exhaust "Do Not Block"
4	2x 3/4" Conduit Connection
5	2x 1/4" NPT Test Connection

Series 8100 Valve Body: 2.5" CP, 3" CP, 4" CP

Body Connection A & C

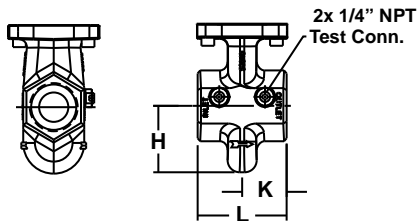

Body Connection B, D & H

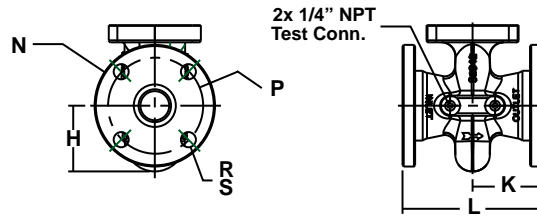

Body Connection E

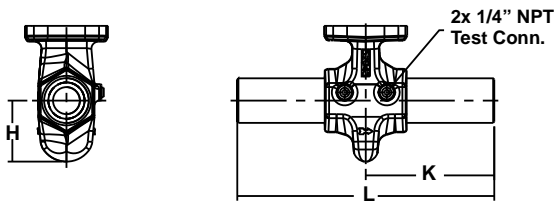

Body Connection F & G

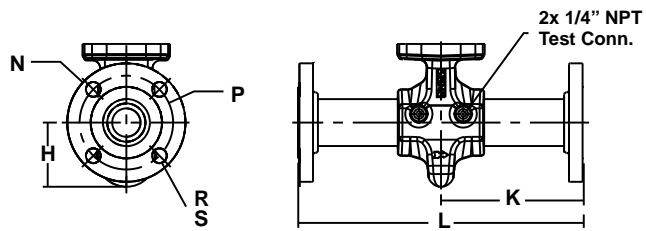

Valve Size	Flow Capacity	Body Connection	Body/Bonnet Material	Approximate Dimensions (in inches)						Approximate Weight (in lbs)			
				H	K	L	N Ø	P Ø	R Ø	S # of holes	Body Assembly	Actuator Assembly	Total Weight
2.5"	C	A, C	Cast Iron	4.3	2.5	5.0	N/A				19	13	32
		B		4.5	3.8	7.5	7.0	5.5	0.75	4	31		44
		D					7.3	5.7	0.75		31		44
		H	7.3				5.7	0.75	8	31	44		
		B	Carbon Steel & Stainless Steel	7.0	5.5	0.75	4	34	47				
		D		7.3	5.7	0.71		34	47				
	H	7.3		5.7	0.71	8	34	47					
	C	G	CS & SS	4.4	6.1	12.3	7.5	5.9	0.88	8	39		51
	3"	C	A, C	Cast Iron	5.1	2.8	5.5	N/A					27
B			5.2		4.0	8.0	7.5	6.0	0.75	4	48	61	
D, H				7.9			6.3	0.75	8	48	61		
B			Carbon Steel & Stainless Steel	7.5	6.0	0.75	4	49	62				
D, H		7.9		6.3	0.71	8	49	62					
C		G	CS & SS	5.2	6.6	13.3	8.3	6.6	0.88	8	56	68	
4"	C	B	Cast Iron	5.5	4.5	9.0	9.0	7.5	0.75	8	66	79	
		D, H					8.7	7.1	0.75		66	79	
		B	Carbon Steel & Stainless Steel				9.0	7.5	0.75		67	80	
		D, H					8.7	7.1	0.71		67	80	
	C	G	CS & SS	5.1	7.4	15.3	10	7.9	0.88	8	83	95	

Flow Capacity:
S - Standard
C - CP Body Construction

Body Connection:
A - NPT
B - ANSI Flanged (ISO 7005 PN20)
C - ISO 7-1Threaded
D - DIN PN16 Flanged
E - Socket Welded Nipples
F - Socket Welded Nipples w/ Class 150 Flange (ISO 7005 PN20)
G - Socket Welded Nipples w/ Class 300 Flange (ISO 7005 PN50)
H - EN1092-1 PN16 (ISO 7005-1 PN16)

Series 8100 Actuator: 2.5" CP, 3" CP, 4" CP

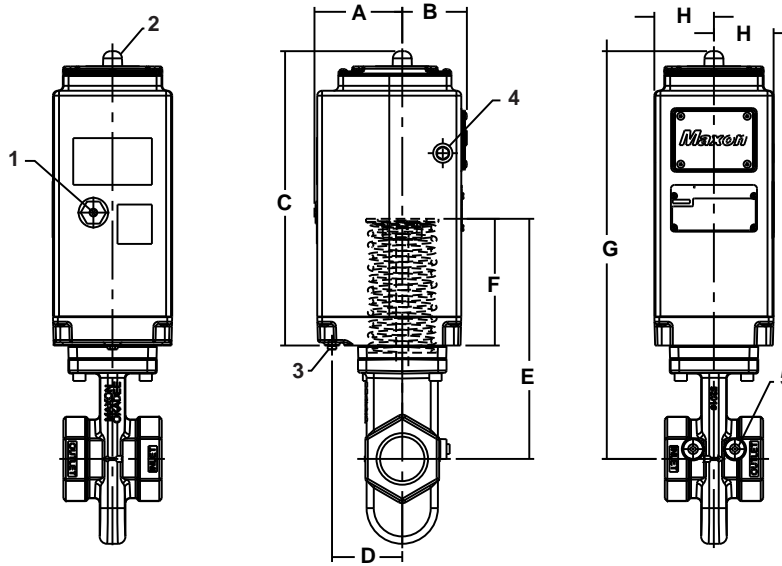

Valve Size	Flow Capacity	Approximate Dimensions (in inches)							
		A	B	C	D	E	F	G	H
2.5"	CP	4.5	3.3	15.0	3.6	12.2	6.4	20.7	3.0
3"	CP					12.9		21.5	
4"	CP								

1	1/8" NPT Air Inlet Connection
2	Visual Indication of Valve Position
3	Air Exhaust "Do Not Block"
4	2x 3/4" Conduit Connection
5	2x 1/4" NPT Test Connection

Series 8000 and 8100: 6"

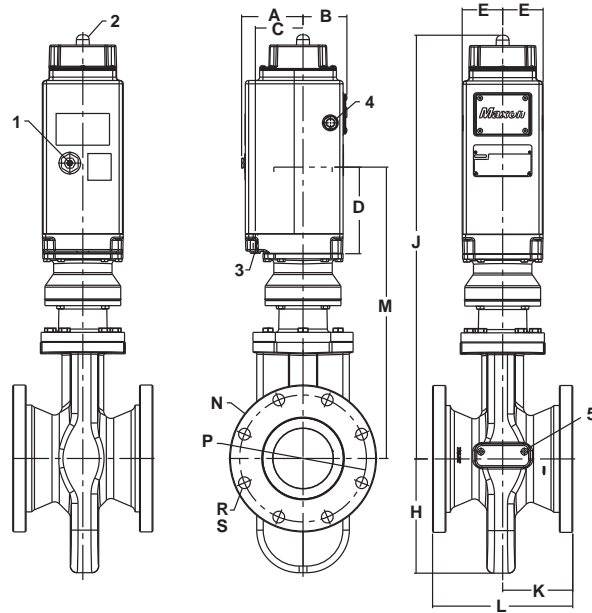

Valve Size	Flow Capacity	Body Conn.	Body/Bonnet Material	Approximate Dimensions (in inches)													Approximate Weight (in lbs)			
				A	B	C	D	E	H	J	K	L	M	N Ø	P Ø	R Ø	S #of holes	Body Assembly	Actuator Assembly	Total Weight
6"	S	B	Cast Iron	4.6	3.3	3.6	6.5	3.0	8.6	31.7	5.25	10.5	21.8	11.0	9.5	0.88	8	117	23	140
		D																117		140
		B	Carbon Steel & Stainless Steel															126		149
		D																126		149

Flow Capacity:
S - Standard

Body Connection:
B - ANSI 150 lbs (ISO7005 - PN20)
D - DIN PN16 Flanged

1	1/8" NPT Air Inlet Connection
2	Visual Indication of valve position
3	1/8" NPT Air Exhaust "Do Not Block"
4	2x 3/4" Conduit Connection
5	2x 1/4" NPT Test Connection

Accessories

Speed Control Set Kits

Manually adjustable valve restricts flow to the actuator inlet and so reduces opening speed of the normally closed shut-off valve or reduces the closing speed of normally open vent valves.

- Available in carbon steel and stainless steel construction
- 90° mating elbow provided for easy assembly
- Tamper-proof set screw prevents accidental misadjustment



Kit No. 1067124
Carbon Steel construction



Kit No. 1067125
Stainless Steel construction

Intrinsic Safety Interfaces

Approved units interposed between the hazardous and safe area circuits limit parameters such as voltage, current or power.

- Suitable for use in Class I, Div. 2 areas
- DIN rail mounted
- Complements intrinsically safe Series 8000 Valves

Engineering recommendations for barriers and isolator option				
Manufacturer	IS interface type	Model no.	Application	MAXON no.
MTL	Zener Diode [1]	MTL 7728+	Solenoid	1067656
		MTL 7787+	Switch [2]	1067655
	Isolator [3]	MTL 5025	Solenoid	1067660
		MTL 5018	Switch [4]	1067659

[1] Circuit must be isolated from earth in hazardous area

[2] Two barriers required for VOS1 / VCS1

[3] Circuit may be earthed at one point in hazardous area

[4] One barrier required for VOS1 / VCS1

