

JBPH Series

Back Pressure Regulating Valve

BACK PRESSURE REDUCING VALVE

The JBPH Series is a piston operated back pressure regulator. The 0.5 Cv offers increased flows across its 6000 psi inlet range, while the Kel-F soft seat provides ANSI Class VI shutoff. Four set spring ranges and three soft seal options offer flexibility in a number of applications and environments. These valves are designed to regulate a variety of gases and liquids from pump and compressor control to process pressure control where high flows and high pressures are required.

Features:

- In-line removable plug and trim provides for quick cleaning and maintenance
- All wetted materials are 316L or 416 stainless steel; other materials available on application
- Large 0.5 CV offers high flows with setpoints up to 5800 psi
- Optimized internal volume
- Kel-F soft seat for ANSI Class VI shutoff
- Captured vent to monitor seal integrity



JBPH SERIES FLOW CONFIGURATIONS

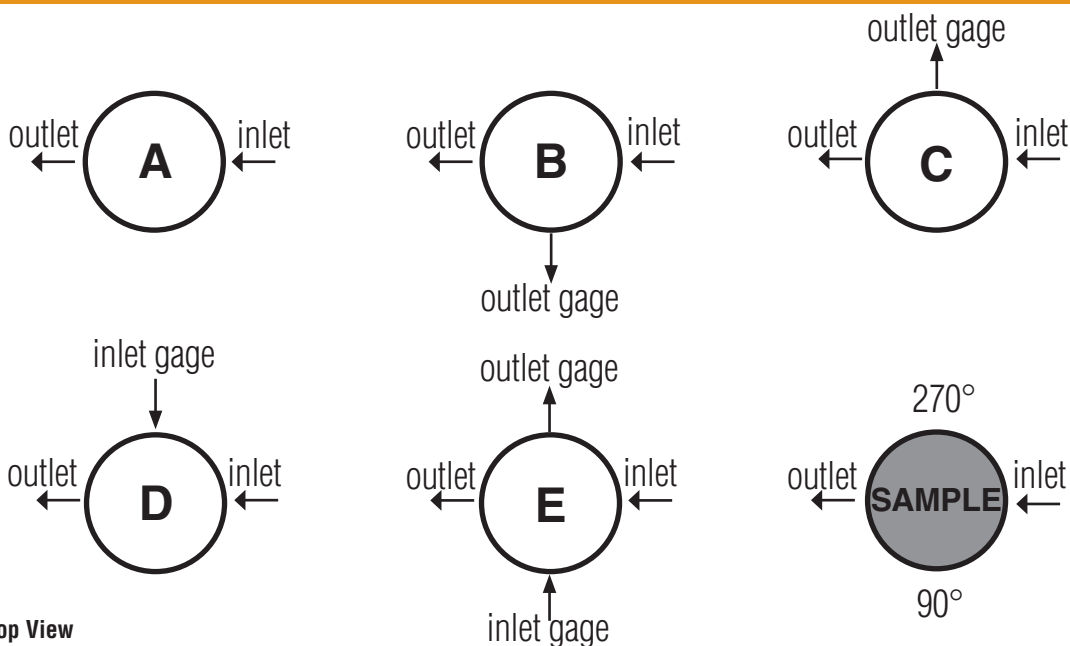

Top View

Gage ports are 1/4" FNPT; Consult factory for other porting options

JBPH SERIES SPECIFICATIONS

Line Size: 1/2", 3/4", 1" (DN15, 20, 25)

Materials

- Body & Trim: 316L SST
- Spring Housing: 316L SST
- Plug: 416 SST
- Seat Insert: KEL-F
- Body Seals: Elastomer o-rings (Buna-N, EPDM, Viton)

Inlet Pressure: 6,000 psi (413,8 bar)

Spring Ranges:

- Black: 0 – 2150 psi (0 – 148,3 bar)
- Black: 0 – 2500 psi (0 – 172,4 bar)
- Orange: 0 – 4060 psi (0 – 280 bar)
- Green: 0 – 5800 psi (0 – 400 bar)

Seat Diameter: 0.197" (5mm)

Maximum Allowable Pressure: 6,000 psi max inlet @ 100°F (413,8 bar @ 38° C)

Maximum Operating Temperature: 4,900 psi max inlet @ 250°F (338 bar max inlet @ 121°C)

End Connections

- Threaded Ends – FNPT or BSPP
- Socket Weld
- Flanged

Gauge Port: 1/4" NPT (optional)

Temperature Range: -29°F to +250°F (-34°C to +121°C) - actual range depends on choice of seal materials

Shutoff: Class VI

Flow Capacity: Cv 0.5 (0,43 Kv)

Optional Cleaning: For oxygen service, oil free service

Options:

- Panel Mounting
- Locking Wire
- Tamper Proof
- Lockout Device

Panel Mount- The panel mount feature utilizes a threaded spring housing and a panel mount ring to secure the regulator to an instrument panel.

Locking Wire- The locking wire option utilizes a lead sealed metal wire to physically hold the adjusting screw in place to prevent any unwanted set point changes.

Tamper Proof- The tamper proof option replaces the standard adjusting knob with a stainless steel acorn nut.

Lockout Device- The lockout device is a 2 piece polypropylene enclosure which encapsulates the adjustment knob and prevents unwanted set point changes. The part number required for this valve is 26971. (Lock not included)

JBPH SIZING

1. Use the "LVCV Sizing Software" link found on the www.lowflowvalve.com home page and navigate to LowFlow valve sizing.
2. Use the software to size for flow using the listed CV of the valve and the customer's application conditions.
3. The JBPH is rated to 50% of the flow value found using LVCV. There is no low-end cutoff limit.

Example:

Air, ambient temperature, P1 = 4000 psi, P2 = 0 psi, 1/2" schedule 40 pipe, flow rate 20,000 SCFH

Using LVCV to size for flow we find that these conditions and a 0.5 CV will result in a maximum flow of 65,886 scfh. Multiply this value by 0.50 to find the maximum rated flow for the JBPH. Your result will be 32,943 scfh (65,886 x 0.5 = 32,943). Any flow below this result is acceptable for the valve.

JBPH SERIES FEATURES AND BENEFITS

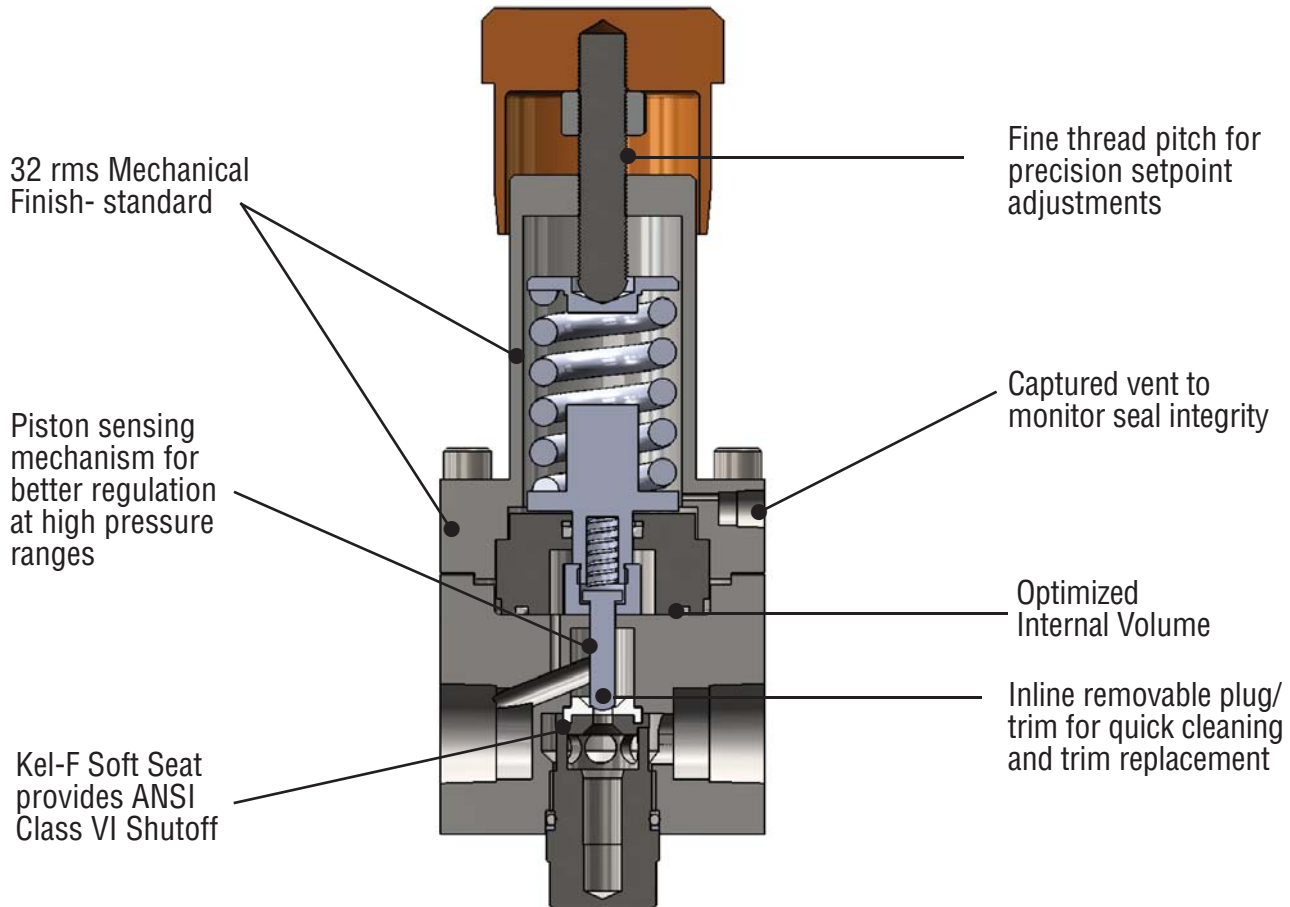

JBPH DIMENSIONS

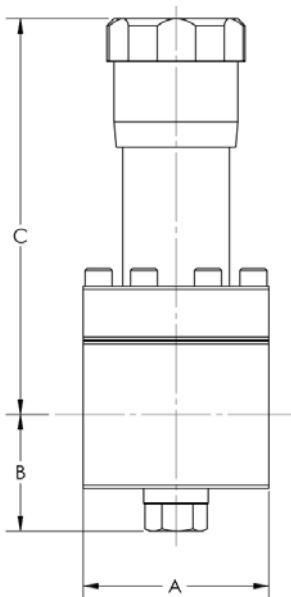

VALVE SIZE	DIMENSIONS, INCHES			WEIGHT, LBS
	A	B	C	
1/2"	2.8	2.1	7.5	7.7
3/4"	3.2	1.8	7.5	9.9
1"	3.2	1.8	7.5	9.9

VALVE SIZE	DIMENSIONS, MM			WEIGHT, KGS
	A	B	C	
DN15	71	53	191	3.5
DN20	81	46	191	4.5
DN25	81	46	191	4.5

JBPH SERIES ORDERING SCHEMATIC

Model	Size	Material	1 & 2	3 & 4	5 & 6	7 & 8	9 & 10	11 & 12	13 & 14	15	16	17
—	—	—	—	—	—	—	—	—	—	—	—	—

Model	
JBPH	Back Pressure Regulating Valve

Size	
050	1/2"
075	3/4"
100	1"

Material	
6L	Stainless Steel 316L

1 & 2	Body Feature		
End Connection	Port Configuration		
C	FNPT 1/2"	A	Port "A"
D	FNPT 3/4"	B	Port "B"
E	FNPT 1"	C	Port "C"
F	BSPP 1/2"	D	Port "D"
G	BSPP 3/4"	E	Port "E"
H	BSPP 1"		
ZZ	Non-Standard		

3 & 4	Trim
BB	Buna-N
EE	EPDM
VV	Viton
ZZ	Non-Standard

5 & 6	Seat
K5	KEL-F Cv 0.5
ZZ	Non-Standard

7 & 8	Range Spring/Outlet Pressure
H1	0 - 2150 psi
H2	0 - 2500 psi
H3	0 - 4060 psi
H4	0 - 5800 psi
ZZ	Non-Standard

9 & 10	Piston
00	Standard
ZZ	Non-Standard

11 & 12	Actuator
SK	Standard
ZZ	Non-Standard

13 & 14	Inlet Gauge
LL	0 - 3000 PSIG/BAR (Dual)
MM	0 - 5000 PSIG/BAR (Dual)
PP	0 - 10000 PSIG/BAR (Dual)
NN	None
ZZ	Standard

15	Outlet Gauge
K	0-2000 PSIG/ BAR (DUAL)
L	0-3000 PSIG/ BAR (DUAL)
M	0-5000 PSIG/ BAR (DUAL)
P	0-10000 PSIG/ BAR (DUAL)
N	None
Z	Non-Standard

16	SEP Compliance
G	SEP Compliant
0	None
Z	Non-Standard

17	Accessories
S	Clean for Oil Free
X	Clean for Oxygen
0	None
Z	Non-Standard

LowFlow Valve reserves the right to make revisions to its product, specifications, literature and related information without notice. Please visit our website at www.lowflowvalve.com for the latest information on our products.