



JORDAN VALVE

3170 Wasson Road • Cincinnati, OH 45209 USA
Phone 513-533-5600 • Fax 513-871-0105
info@richardsind.com • www.jordanvalve.com

I & M Mk 701/702/707/711 Series

Installation & Maintenance Instructions for Mark 701/702/707/711 Control Valves

Warning: Jordan Valve control valves must only be used, installed and repaired in accordance with these Installation & Maintenance Instructions. Observe all applicable public and company codes and regulations. In the event of leakage or other malfunction, call a qualified service person; continued operation may cause system failure or a general hazard. Before servicing any valve, disconnect, shut off, or bypass all pressurized fluid. Before disassembling a valve, be sure to release all spring tension.

Please read these instructions carefully!

Your Jordan Valve product will provide you with long, trouble-free service if it is correctly installed and maintained. Spending a few minutes now reading these instructions can save hours of trouble and downtime later. When making repairs, use only genuine Jordan Valve parts, available for immediate shipment from the factory.

Ideal Installation

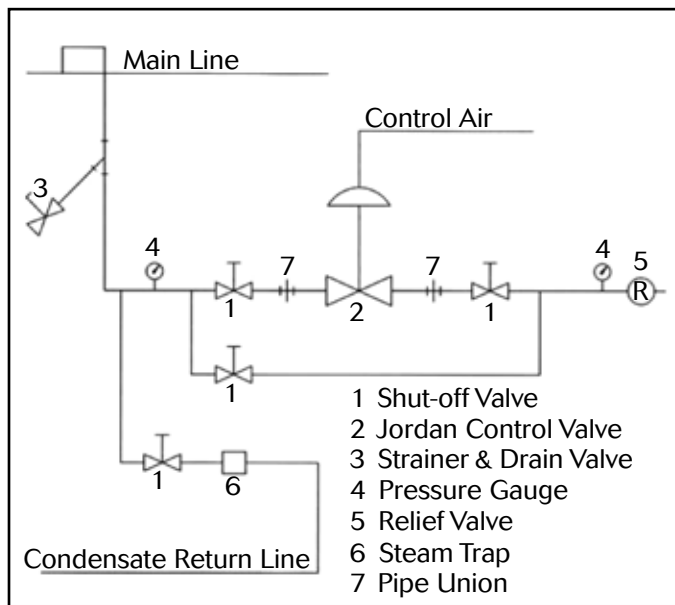

Preferred Installation

- To protect the valve from grit, scale, thread chips, and other foreign matter, all pipe lines and piping components should be blown out and thoroughly cleaned before the valve is installed.
- Shutoff valves, pressure gauges, and bypass piping should be installed as indicated in the Ideal Installation Schematic to provide easier adjustment, operation, and testing.
- A line strainer should be installed on the inlet side of the regulator to protect it from grit, scale and other

- foreign matter. A 0.033 perforated screen is usually suitable. Line strainers are available from Jordan Valve.
- For best control, 3'0" straight sections of pipe should be installed on either side of the valve.
- In preparing threaded pipe connections, care should be exercised to prevent pipe-sealing compound from getting into the pipelines. Pipe sealing compound should be used sparingly, leaving the two end threads clean. Jordan uses, and recommends, thread sealer Teflon ribbon.
- The flow arrow on the valve body must be pointed in the direction of flow. Ideally, the valve should be installed in the highest horizontal line of piping to provide drainage for inlet and outlet piping, to prevent water hammer, and to obtain faster response.
- If possible, install a relief valve downstream from the valve. Set at 15 psi above the control point of the valve.
- In hot vapor lines, upstream and downstream piping near the valve should be insulated to minimize condensation.
- In gas service, if the control pressure (downstream) is 25% of the inlet pressure or less, expand the outlet piping at least one pipe size. A standard tapered expander connected to the outlet of the valve is recommended.
- Where surges are severe, a piping accumulator is recommended.
- On steam control applications, install a steam trap with sufficient capacity to drain the coil or condenser. Be sure to have a good fall to the trap, and no back pressure. Best control is maintained if the coil or condenser is kept dry.

Start-Up

- Be sure that the action of the control valve and of the controller are such as to give the desired results.

If an increase in pressure or temperature must:	And the action of the valve is:	Then the action of the controller must be:
close valve	air-to-close (direct)	direct
close valve	air-to-open (reverse)	reverse
open valve	air-to-close (direct)	reverse
open valve	air-to-open (reverse)	direct

2. The control valve has been pre-set by Jordan Valve. However, finer adjustments may be required to compensate for pressure drop conditions of the application.
3. With the inlet, outlet, and bypass shutoff valves closed, and no pressure in the downstream line, fully open the outlet shut off valve. Increase flow gradually by slowly opening the inlet shutoff valve. Do not fully open the inlet valve until you are sure that the controller and control valve have control of the system. Usually, the handwheel on the inlet valve will turn freely when this point is reached.
4. To shut off the line fluid, close the inlet shut-off valve first, then the outlet shut-off valves.
5. Body and cap bolts should be retightened per torque procedures after valve reaches operating temperature.

Valve Maintenance

Caution: Make certain that there is no pressure in the valve before loosening any fittings or joints. The following steps are recommended.

1. Close inlet shutoff valve.
2. Allow pressure to bleed off through downstream piping. Do not attempt to reverse the valve by bleeding pressure from the upstream side of the valve.
3. When the pressure gauges indicate that all pressure has been removed from the system, close the outlet shutoff valve, and the valve may be serviced.

Note: refer to the drawing at the end of this document for description and proper orientation of parts.

Valve Seats

1. Follow instructions under Maintenance section to remove valve from line.
2. Disassemble the valve only as far as necessary to do the required work. See Valve Disassembly section.
3. When replacing seats it is recommended by Jordan Valve that the packing be replaced if the valve is older than one year. Follow the instructions under Packing.

Valve Disassembly/Reassembly

1/2" to 1-1/4" Sizes

1. To remove the control valve from the line, follow the instructions under MAINTENANCE.
2. Secure the body hex in the vise. Remove the cap screws (3) and lift the cap (2) straight up.
3. Next, remove the plate (5) and place it on the bench with the lapped surface up. You will notice that there is also a locating pin that aligns the plate with the disc guide. This locating pin should be on the same

side as the "<" on the body and cap.

4. Now, remove the disc (6) and disc guide (4), placing the disc on the bench with the lapped surface up. Fingertip pressure should be sufficient to remove these parts.

It is critical that the disc pin not be rotated when disassembling, cleaning, or reassembling, since this affects the stroke adjustment.

5. Clean all parts of the body and cap with a good quality solvent. The disc and plate can then be cleaned. Place a 4/0 polish cloth or jeweler's cloth on a smooth, flat surface and polish the lapped surfaces. If the parts are badly scarred, do not attempt to relap them, but return them to the factory for repair or replacement. If the parts are not scarred too deeply, they can be repaired at minimal cost.
6. A 0.005 feeler gauge should be used to check the clearance between the disc and the disc guides. If the clearance is less than 0.005", clean the disc guides with a smooth file.

For Reassembly

7. Place the disc guide (4) in the body bore with the locating pin on the same side as the "<" on the body.
8. Place the disc (6) in the aperture of the disc guide (4) with the arrow pointing to the index pin hole and engage the disc pin (8).
9. In placing the plate (5) in the body (1), notice that the index pin hole in the lapped surface of the plate engages the index pin of the disc guide (4).
10. Replace the cap (2).
11. Tighten the cap screws (3) uniformly, being cautious not to apply too much torque. See Torque Requirements.

1-1/2" & 2" Sizes

1. To remove the control valve from the line, follow instructions under MAINTENANCE.
2. Secure the body hex in a vise. Remove the cap bolts (3) and lift the cap (2) straight up.
3. Remove the pressure ring (4A). Remove the disc (6) and plate (5) assembly by lifting the assembly straight up from the body. Place the assembly on the bench with the disc up.

It is critical that the disc pin not be rotated when disassembling, cleaning, or reassembling, since this affects the stroke adjustment.

4. Clean the body and cap bores with a good quality solvent.
5. To clean the disc and plate, remove the guide screws. Place a 4/0 polish cloth or jeweler's cloth on a smooth, flat surface and polish the lapped surfaces. If the parts are badly scarred, do not attempt to

relap them, but return them to the factory for repair or replacement. If the parts are not scarred too deeply, they can be repaired at minimal cost.

For Reassembly:

6. Place the disc (6) on the plate (5) and replace the guide screws (7). Tighten the guide screws but do not allow the screws to bind the disc against the plate.
7. Replace the disc and plate assembly and the pressure ring. Make sure that the disc pin engages the disc and that the plate seats solidly against the plate seat in the body.
8. Replace the cap and cap bolts, and tighten uniformly, being careful not to torque excessively. See Torque Requirements.

2-1/2" & 6" Sizes

1. To remove the control valve from the line, follow instructions under MAINTENANCE.
2. Remove body cap bolts (3) and pull the cap (2) from the body (1). Notice that the cap has an internal vertical web on which the disc spring (7A) is located. Check the condition of the disc trap.
3. Remove the disc (6) and place it on the bench with the lapped surface facing up.
4. Remove the plate (5) and place it on the bench with the lapped surface up. Finger pressure should be sufficient to remove the plate. If not, strike gently from the rear, using a blunt, nonmetallic object. Notice that the plate is positioned in the body by two index pins (7B). These pins are secured in the body and extend through the plate gasket (40) and into the holes in the plate. These pins prevent the plate from rotating in the body.

It is critical that the disc pin not be rotated when disassembling, cleaning, or reassembling, since this affects the stroke adjustment.

5. Clean all of the parts of the body and cap with solvent. The disc and plate then may be cleaned. Place a piece of 4/0 polishing cloth or jewelers cloth on a smooth, flat surface such as a surface plate, and polish the lapped surfaces of the disc, plate and disc guide using a "figure 8" motion. If the parts are scarred, do not attempt to relap them, but return them to Jordan Valve for repair or replacement. If the seats are not scarred deeply, they can be repaired at a nominal cost.
6. Reassemble in reverse order.
7. Install the cap screws and tighten uniformly. See Torque Requirements.

Stem, Disc Pin & Packing Replacement

1. Remove disc (6) and plate (5) following the procedure outlined under Valve Seats.
2. Loosen stem connector nut (20) and bolt (19) and remove connector (18).
3. Back out the four allen head yoke screws (23) (1/2" - 2" sizes) or four yoke bolts (42) (2-1/2" - 6" sizes) which will allow the body to be separated from the yoke.
4. Remove the packing flange nuts (17) and the packing flange (15).
5. Loosen the stem locknut (9) and rotate the disc pin (8) counter-clockwise, pulling the valve stem (10) upward while doing so.
6. When pulling the stem completely out of the body, you will remove most of the packing assembly (11) also. The remaining parts of the packing assembly can be "fished" out with a small screw driver.
7. Clean the packing bore in the body with solvent and blow dry.
8. The disc pin may be removed through the body bore.
9. Clean the stem and disc pin with solvent if they are to be reused.
10. Reassemble the disc pin (8), stem (10) and lock nut (9) in the valve body as they originally were.
11. Replace the packing spring (12) and packing retainer (13) in the packing bore.
12. Reassemble the new packing (11) on the stem with the open part of the "V" downward (^). There will be a flat on the top and bottom. Place the packing follower (14) on top of the packing.
13. Gently push the packing into the packing bore and place the packing flange (15) on the stem and over the packing studs (16).
14. Put on the flange nuts (17) and tighten them partially. At this point it is recommended that you gently move the stem up and down three or four times to align the assembly. Tighten the flange nuts until the packing follower bottoms out on the top of the body.
15. Replace actuator in reverse order. Reassemble the valve by inserting seats as outlined in Valve Assembly Section for the size valve you are working with. Then follow the instructions for Seat Alignment.

Actuator / Diaphragm

Caution: do not apply more than 50 psi to actuator

The valve need not be removed from the line, but before performing any maintenance on the actuator, shut off the control air supply and remove the line from the actuator.

Actuator Disassembly

1. Loosen the stem connector bolt (20) and nut (19), and remove the stem connector (18).
2. Remove the actuator assembly from the valve by removing the four adapter plate bolts (22) and lifting the actuator off the yoke (21).
3. Release the spring compression by threading the actuator stem (24) out of actuator, being careful not to loosen the actuator stem locknut (44) or move the stem adapter (43) (on 1/2" to 2" sizes).
4. Remove the actuator case bolts (29) and nuts (30) and lift the upper actuator case (28) off of the lower actuator case.
5. Lift the diaphragm assembly out of the actuator case (27).
6. Loosen and remove the two actuator bolt locknuts (36). Remove the diaphragm plate (33) and diaphragm (34) from the actuator.
7. Clean all parts with a good quality solvent. Remove encrusted material with crocus or very fine aluminum oxide cloth. Inspect all parts for excessive wear and/or damage and replace worn or damaged parts. Use only Jordan Valve Replacement Parts. The use of other than genuine Jordan Valve parts may impair their ability to function properly.

Actuator Reassembly

1. Assemble the diaphragm stops (32), diaphragm (34), and diaphragm plate (33) to the actuator bolt (35). Assemble and tighten the two actuator bolt lock nuts (36) making sure that they are locked together.
2. Place the diaphragm assembly (from step 1) on the upper actuator case (28) with the diaphragm plate (33) up. Place the springs (37) on the diaphragm plate so they nest the formed bosses. Assemble the lower case (27).
3. Replace four of the actuator case bolts (29) and nuts (30) at 90° and tighten finger-tight. Thread the actuator stem (24) (with the stem adapter (42) for the 1/2" to 2" sizes) onto the actuator bolt (35) until the shoulder on the stem connects the adapter plate and a slight amount for spring compression can be felt.
4. Reassemble the actuator assembly to the yoke using the four adapter plate bolts (22).
5. Reconnect the actuator stem (24) to the valve stem (10) using the stem connector (18) and its bolt (19) and nut (20).
6. Adjust the spring preload as shown in Spring Adjustment.

Valve Stroke Adjustment

1. **1/2" to 2" sizes:** loosen the stem connector nut (20), only enough to allow the stem adapter (43) to rotate. **Do not remove the stem connector (18).** Proper positioning of the valve stem and the stem

adapter (43) must be maintained while adjusting the seats.

2. **2-1/2" to 6" sizes:** remove the seats as outlined under **Valve Seats** and loosen the disc pin locknut (9). Put the seats back in place. Loosen the stem connector nut (20) only enough to allow the stem (19) to rotate. **Do not remove the stem connector (18).** Proper positioning of the valve stem (10) and actuator stem (24) must be maintained while adjusting the seats.
3. **Direct Acting (air-to-close) Valves:** thread the actuator stem (24) onto the actuator bolts (35) until the springs are slightly compressed. This insures that the actuator stem is slightly compressed. This insures that the actuator stem is in its fully upward position. To confirm that the actuator stem is fully stroked down, check that it cannot be rotated **easily** with a wrench.
4. **Reverse Acting (air-to-open) Valves:** apply an air pressure to the actuator of approximately 5 psi above the maximum range pressure (i.e. 20 psi for 3-15 psi range). This should stroke the actuator stem fully down. To confirm that the actuator stem is fully stroked down, check that it cannot be rotated **easily** without a wrench.
5. **1/2" to 2" sizes:** the orifices in the disc (6) and plate (5) must be perfectly aligned in the open position. If they are not, loosen the actuator stem locknut (44) and rotate the stem adapter (43), which moves the disc pin (8) and disc (6) up or down on the plate.
6. **2-1/2" to 6" sizes:** the orifices in the disc (6) and plate (5) must be perfectly aligned in the open position. If they are not, adjust the alignment of the orifices by rotating the valve stem (10), which moves the disc pin (8) and disc (6) up or down on the plate (5).
7. **1/2" to 2" sizes:** after proper alignment has been achieved, tighten the locknut (44) against the end of the actuator stem (43). Recheck the seat adjustment.
8. **2-1/2" to 6" sizes:** after proper alignment has been achieved, remove the seat assembly and carefully tighten the disc pin locknut (9), taking care not to rotate the disc pin (8). Replace the seats and recheck the seat alignment.
9. Adjust the spring preload as shown in *Spring Adjustment*.

Spring Adjustment

Note: Actuators arranged for 3-15 range, Reverse Air-To-Open: Jordan control valves rated 3-15 psig, ATO, are bench set at the factory at 5-17 psig. Please insure that any I/P utilized with this control valve is capable of 17 psig output to insure full valve travel. If desired, the range may be changed to suit your needs by following the instructions below.

The signal range (3-15 psi or other) is preset by Jordan Valve. When the valve is installed, however, this range may shift slightly due to pressure drops across the valve.

Additionally, preload adjustments may be required after one of the previous maintenance procedures.

1. Remove the air signal line from the actuator and replace with a pressure gauge and an air regulator.
2. Loosen, but do not remove, the stem connector bolt (19) and nut (20).
3. Adjust the actuator air pressure to just below the starting point of the range and rotate the actuator stem (24) until the stem just starts to move. Continue to rotate the actuator stem about one-half turn. Remove the air pressure. Increase the air pressure and check the pressure at which the valve just starts to move. Repeat actuator stem adjustment if necessary and again check pressure at which the stem starts to move.
4. After the preload has been properly adjusted, tighten the stem connector bolt (19) and nut (20) and reattach the control air line.

Changing Valve Action

The action of a sliding gate valve can be changed from direct to reverse, or vice-versa, by rotating the disc, plate and cap 180°. Check valve stroke and orifice alignment and readjust, if required, as shown under *Valve Stroke Adjustment*.

Torque Requirements

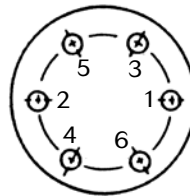

6 bolts (or multiples)

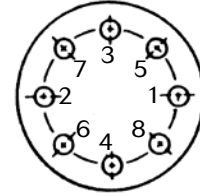

8 bolts (or multiples)

Troubleshooting

Erratic Control

- Oversizing causes cycling or hunting – recalculate size required.
- Steam traps downstream may need reconditioning.
- Excessive foreign matter may be lodged in seats.
- Valve stroke may be out of adjustment.
- Valve disc may not be moving freely.

Will not operate

- Diaphragm ruptured and needs replacement
- Spring(s) broken and needs replacement
- Improper spring setting (reset).

Torque for Bolts Connecting Cap to Body

Valve Size	CI, DI, BRZ	CS, SST
1/2" & 3/4"	110 in-lbs	200 in-lbs
1" & 1-1/4"	120 in-lbs	200 in-lbs
1-1/2" & 2"	140 in-lbs	200 in-lbs
2-1/2" & 6"	1080 in-lbs	1080 in-lbs

Illustration & Part List

1/2" to 1-1/2" Sizes (See seat arrangement at lower portion of drawing for 1-1/2" & 2")

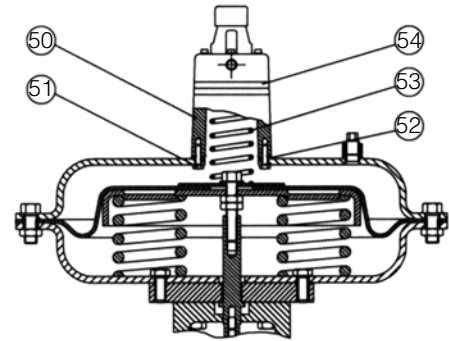
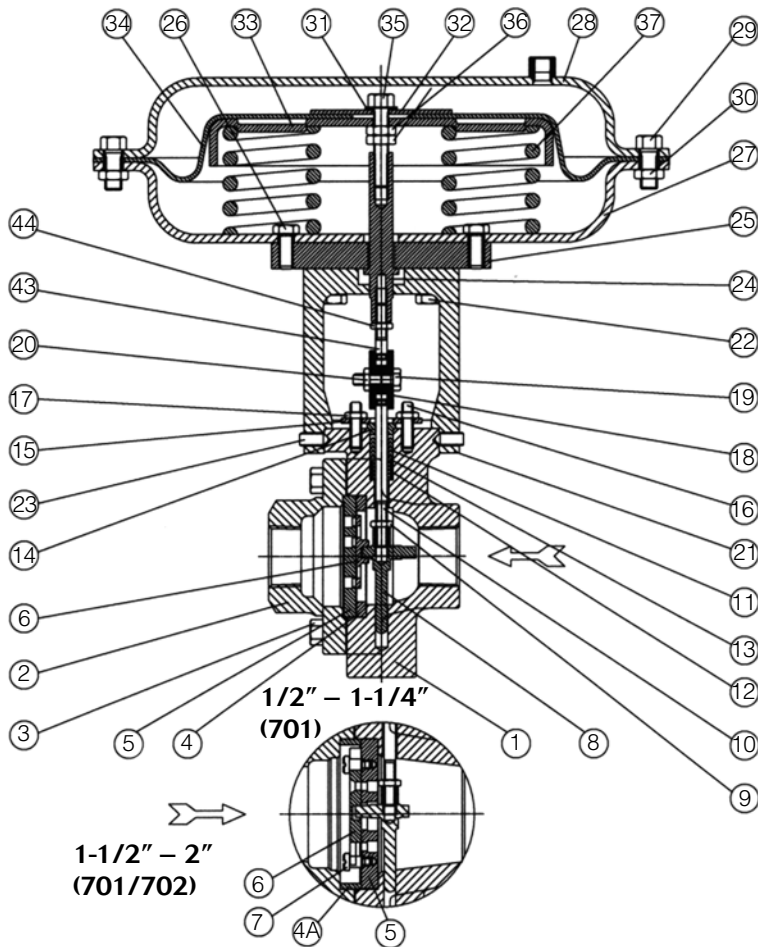

MK701/702

Item	Description	Item	Description	Item	Description
1	Body	15	Packing Flange	30	Actuator Case Nut
2	Cap	16	Packing Stud	31	Seal Washer
3	Bolt (Body - Cap)	17	Packing Nut	32	Diaphragm Stop
4	Disc Guide (1/2" - 1-1/4")	18	Stem Connector	33	Diaphragm Plate
4A	Pressure Ring (1-1/2" - 2")	19	Stem Connector Bolt	34	Diaphragm
5	Plate	20	Stem Connector Nut	35	Actuator Bolt
6	Disc	21	Yoke	36	Actuator Bolt Locknut
7	Guide Screw (1-1/2" - 2")	22	Adapter Plate Bolt	37	Spring
8	Disc Pin	23	Yoke Screw	43	Stem Adapter
9	Stem Locknut	24	Actuator Stem	44	Actuator Stem Locknut
10	Stem	25	Adapter Plate	50	Positioner Adapter Ring
11	Packing	26	Adapter Plate Actuator Bolt	51	Positioner Screw
12	Packing Spring	27	Lower Actuator Case	52	Positioner Gasket
13	Packing Retainer	28	Upper Actuator Case	53	Positioner Spring
14	Packing Follower	29	Actuator Case Bolt	54	Positioner

Illustration & Part List

2-1/2" – 6" Sizes

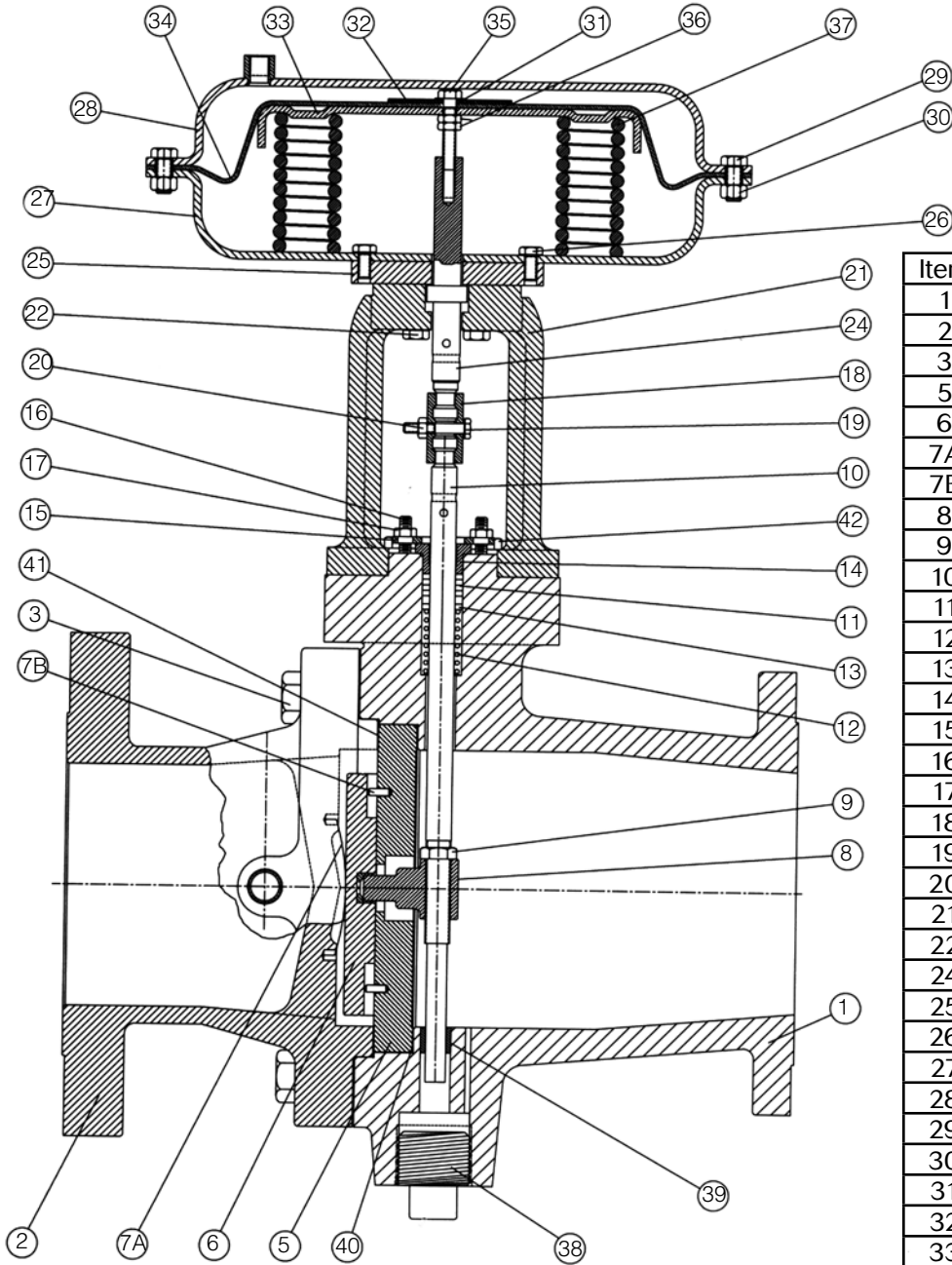

Item	Description
1	Body
2	Cap
3	Cap Bolt
5	Plate
6	Disc
7A	Disc Spring
7B	Disc Guide Pin
8	Disc Pin
9	Stem Locknut
10	Valve Stem
11	Packing
12	Packing Spring
13	Packing Retainer
14	Packing Follower
15	Packing Flange
16	Packing Stud
17	Packing Nut
18	Stem Connector
19	Stem Connector Bolt
20	Stem Connector Nut
21	Yoke
22	Adapter Plate Bolt
24	Actuator Stem
25	Adapter Plate
26	Bolt (Adapter Plate - Actuator)
27	Lower Actuator Case
28	Upper Actuator Case
29	Actuator Case Bolt
30	Actuator Case Nut
31	Seal Washer
32	Diaphragm Stop
33	Diaphragm Plate
34	Diaphragm
35	Actuator Bolt
36	Actuator Bolt Locknuts
37	Spring
38	Pipe Plug
39	Stem Bushing
40	Gasket (Body-Plate)
41	Gasket (Cap-Plate)
42	Yoke Bolt