



flow

SITRANS F M InterMag 2/TransMag 2
Magnetic-inductive flow transmitter
7ME5033, 7ME5034

SIEMENS

SIEMENS

SITRANS F M InterMag 2/TransMag 2

**Magnetic-inductive Flow Transmitters
7ME5033, 7ME5034**

Operating Manual

**Order No. A5E00102775
Release 12/2003**

The reproduction, transmission or use of this document or its contents is not permitted without express written authority. Offenders will be liable for damages. All rights created by the granting of patents or registration of a design are reserved. Technical data subject to change without notice

Weitergabe sowie Vervielfältigung dieser Unterlage, Verwertung und Mitteilung ihres Inhaltes nicht gestattet, soweit nicht ausdrücklich zugestanden.
Zu widerhandlungen verpflichten zu Schadenersatz. Alle Rechte vorbehalten, insbesondere für den Fall der Patenterteilung oder GM-Eintragung. Technische Änderungen vorbehalten.

Toute communication ou reproduction de ce document, toute exploitation ou communication de son contenu sont interdites, sauf autorisation expresse. Tout manquement à cette règle est illicite et expose son auteur au versement de dommages et intérêts. Tous nos droits sont réservés pour le cas de la délivrance d'un brevet ou celui de l'enregistrement d'un modèle d'utilité. Modifications techniques sont réservées

La divulgación y reproducción de este documento así como el aprovechamiento de su contenido, no están autorizados, a no ser que se obtenga el consentimiento expreso, para ello. Los infractores quedan obligados a la indemnización por daños y perjuicios. Se reservan todos los derechos, en particular para el caso de concesión de Patente o de Modelo de Utilidad.
Salvo modificaciones técnicas

La trasmissione a terzi e la riproduzione di questa documentazione, cosiccome lo sfruttamento del suo contenuto non è permesso, se non autorizzato per iscritto. Le infrazioni comporteranno una richiesta di danni. Tutti i diritti sono riservati, in particolare nel caso di brevetti. Modifiche tecniche possibili.

ULTRAMAT, OXYMAT, SIPAN, SIMATIC, SIPART, SIREC, SITRANS are Siemens AG registered trademarks.
All other product or system names are (registered) trademarks of their respective owners and must be treated accordingly.
According to the German law on units in measuring technology, data in inches only apply to devices for export.

ULTRAMAT, OXYMAT, SIPAN, SIMATIC, SIPART, SIREC, SITRANS sind Marken der Siemens AG.
Die übrigen Bezeichnungen in diesem Handbuch können Marken sein, deren Benutzung durch Dritte für deren Zwecke die Rechte der Inhaber verletzen können.
Die Angaben in Zoll (inch) gelten gemäß dem Gesetz über Einheiten im Meßwesen" nur für den Export.

ULTRAMAT, OXYMAT, SIPAN, SIMATIC, SIPART, SIREC, SITRANS sont des marques déposées de Siemens AG.
D'autres dénominations utilisées dans ce document peuvent également être des marques déposées dont l'utilisation par des tiers à leurs propres fins peut enfreindre les droits des propriétaires desdites marques.

ULTRAMAT, OXYMAT, SIPAN, SIMATIC, SIPART, SIREC, SITRANS son marcas registradas de Siemens AG.
Las otras designaciones que figuran en este documento pueden ser marcas cuya utilización por terceros para sus propios fines puede violar los derechos de los propietarios de dichas marcas.
Conforma a la "Ley sobre las unidades de medida", las dimensiones en pulgadas sólo son válidas para la exportación.

ULTRAMAT, OXYMAT, SIPAN, SIMATIC, SIPART, SIREC, SITRANS sono marchi registrati di Siemens AG.
Le denominazioni di altri prodotti menzionati in questa documentazione possono essere marchi il cui uso da parte di terzi può violare i diritti di proprietà.
Conformemente alla "Legge sulle unità di misura" i dati in pollici valgono soltanto per l'esportazione.

Contents

1	Information for the User	1-1
2	Technical Description	2-1
2.1	Application Range	2-2
2.2	Special Characteristics	2-3
2.3	Operation	2-3
2.4	Technical Data	2-3
2.5	Control and display unit	2-6
2.6	Ordering Data	2-8
2.7	Dimensions	2-9
3	Installation	3-1
3.1	General Information	3-2
3.2	Installation in Pipelines	3-2
3.2.1	Potential equalization (reference potential)	3-2
3.2.2	Sensor	3-3
3.2.3	Probes	3-6
3.2.4	Accessories	3-6
3.3	Control and Display Unit	3-7
3.4	Electrical Connection	3-8
3.4.1	General Information	3-8
3.4.2	Connection of the Power Supply	3-10
3.4.3	Connection of the signal cables	3-10
3.4.4	Connection of the magnetic current and electrode line (remote version only)	3-12
3.4.5	Connection of the 711/A, 711/E (remote version) and 911/E Sensors	3-17
3.4.6	Connection of the 711/F5 and 911/F5 Sensors	3-18
3.4.7	Connection of the 711/S sensor and the S1 and S2 probes (Intermag 2 only)	3-19
3.5	Assembly of the remote version	3-20
3.5.1	Assembly with standard mounting plate	3-20
3.5.2	Assembly with assembly bracket for pipe and wall mounting	3-21
3.6	Special information for devices with explosion protection	3-22

4	Commissioning	4-1
4.1	Safety Instructions	4-2
4.2	Preparations for Commissioning	4-2
5	Operation	5-1
5.1	General Information	5-2
5.2	Operating concept of the control and display unit	5-4
5.2.1	Operating elements	5-4
5.2.2	Disabling or enabling the programming	5-6
5.2.3	Operating examples	5-6
5.2.4	Setting options and factory setting	5-9
5.3	Device Functions and Parameters	5-23
5.3.1	Function Group Display	5-23
5.3.2	Function Group Diagnostics	5-25
5.3.3	Function Group Measuring Functions	5-27
5.3.4	Function Group Device Outputs	5-35
5.3.5	Function Group Identification	5-42
5.3.6	Function Group Service	5-43
5.4	PROFIBUS Communication	5-47
5.4.1	Cyclic Data Traffic	5-48
5.4.1.1	Input Data (from Slave to Master)	5-48
5.4.1.2	Output Data (from Master to Slave)	5-51
5.4.1.3	Device Database File (GSD)	5-51
5.4.2	Acyclic data traffic	5-52
5.4.3	Diagnostics	5-53
5.4.4	Locking operation	5-56

6	Maintenance and Elimination of Faults	6-1
6.1	Maintenance	6-2
6.2	Repairs	6-2
6.3	Elimination of Faults	6-2
6.3.1	Changing fuses	6-2
6.3.2	Error Messages	6-4
6.3.2.1	Application Problems	6-4
6.3.2.2	Troubleshooting	6-7
6.4	Cleaning	6-8
7	Appendix	7-1
7.1	Certificates	7-2
7.1.1	CE Declarations of Conformity	7-2
7.1.2	EC-Type Examination Certificate	7-6
7.2	Application Questionnaire	7-15
7.3	Contents of the Device-specific Control System Files	7-17
7.3.1	Bitmap (Graphic Symbol)	7-17
7.3.2	GSD (Device Database File)	7-17
7.4	Literature List	7-20
7.5	List of abbreviations	7-21

Information for the User

1

Dear customer,

Please read this manual before starting work!

It contains important information and data which guarantee the device's availability and save you service costs when observed. This makes handling this measuring instrument much easier and leads to reliable measuring results.

The product described in the manual has left the factory in a perfect, tested condition with regard to its safety. In order to maintain this condition and to ensure perfect and safe operation of this product it may only be used in the manner described by the manufacturer. In addition, the perfect and safe operation of this product is conditional upon proper transport, proper storage and installation and careful operation and maintenance. This manual contains the information required for use for the intended purpose of the product it describes.

This manual is an integral part of the scope of delivery even it was delivered separately for logistic reasons. For reasons of simplicity it does not contain all details on all versions of the described product nor can it cover every situation which could arise during installation, operation, maintenance and use in systems. If you require further information or if problems which are not dealt with in sufficient detail in this document arise, please request the desired information from your local or responsible Siemens branch.



Note

We recommend that you discuss your application with our consultants especially before using the device for new applications, for example in research and development.

Area of validity

This manual describes the use of the SITRANS FM InterMag 2/ TransMag 2 transmitter. This device is normally operated in conjunction with sensors or probes. **The data sheets/instructions of the enclosed sensor or probe must therefore be observed when using this transmitter** in addition to this manual!

The functions of the device described in this manual correspond to software version 3.0.



This manual describes how to use, start, operate and maintain the device.

You must pay particular attention to the **warnings and notices**. These are highlighted against the rest of the text and marked by special pictograms (see the examples below). They give you valuable tips to avoid operating errors.

The warnings notices in this manual and on the device have the following meanings:

**Danger**

means that failure to take the necessary safety precautions **will** result in death, serious injury and/or considerable material damage.

**Warning**

means that failure to take the necessary safety precautions **could** result in death, serious injury and/or considerable material damage.

**Caution**

with a warning triangle means that failure to take the necessary precautions **may** lead to minor injury.

Caution

without a warning triangle means that failure to take the necessary precautions **may** lead to material damage.

Attention

means that failure to observe the appropriate notice may lead to an undesirable event or condition.

Note

is an important piece of information about the product itself, the handling of the product or that part of the manual to which particular attention is to be drawn.



We would like to point out that the contents of this manual are not part of a previous or existing agreement, promise or legal relationship or an amendment thereto. All obligations of the Siemens AG ensue from the respective contract of purchase which also contains the full, exclusively valid warranty agreement. These contractual warranty conditions are neither extended nor restricted by the contents of this manual.



Warning

This device may only be installed and operated when qualified personnel has previously ensured that a suitable power supply is used to guarantee that the device can carry no dangerous high voltages in normal operation or in the event of a fault in the system or parts thereof.

The sensor connected to this device may be operated with aggressive media and under pressure. Therefore serious injuries and/or considerable material damage cannot be ruled out in the event of improper handling of the device.

The perfect and safe operation of this device is conditional upon proper transport, proper storage and installation and assembly and careful operation and maintenance.

The operational reliability and protection of the device are only guaranteed when the device is operated in accordance with the instructions set down in the manual.

The flow measuring device must be used exclusively for the purpose for which it was intended.

Qualified Personnel

Qualified personnel are persons familiar with the installation, assembly, commissioning and operation of the product and possessing qualifications suitable for their respective activities, e.g.:

- training or instruction or authorization to operate and maintain devices/systems according to the standard of safety technology for electrical circuits, high pressures and corrosive media.
- For devices with explosion protection: training or instruction or authorization to carry out work on electrical circuits for systems with an explosion risk.
- training or instruction according to the standards of safety engineering in the care and use of suitable safety equipment.

Technical Description

2

2.1	Application Range	2-2
2.2	Special Characteristics	2-3
2.3	Operation	2-3
2.4	Technical Data	2-3
2.5	Control and Display Unit	2-6
2.6	Ordering Data	2-8
2.7	Dimensions	2-9

2.1 Application Range

SITRANS F M InterMag /TransMag 2 are microprocessor-controlled transducers with integrated plain text displays in several languages. The transducers record and process the measuring signals from the corresponding magnetic inductive measuring sensors from the SITRANS F M series. They are available as basic and compact designs and are suitable for use with medium flow speed of up to 12m/s.

All types of the InterMag 2 transducer can be connected to the SITRANS F M 711/A and 711/E measuring sensors. The remote design can also be connected to the SITRANS F M 711/S and 711/F5 sensors and the S1 and S2 probes. The InterMag 2 transducers are suitable for use with media with a minimum conductive capacity of $3 \mu\text{S}/\text{cm}$ due to their direct magnetic field.

All types of the TransMag 2 transducer can be connected to the SITRANS F M 911/E measuring sensor. The remote design can also be connected to the SITRANS F M 911/F5 measuring sensor. The TransMag 2 transducers are suitable for use with media with a very low conductive capacity (from approx. $0,008\mu\text{S}/\text{cm}$), media with a high concentration of solids, pulsing media and two-phase materials, due to their high alternating field.

The main application range of the SITRANS FM transmitter can be found in the following fields:

- water, waste water
- power generation and distribution
- chemical and pharmaceutical industry
- food and beverage



Figure 2-1 SITRANS F M InterMag 2/TransMag 2 magnetic-inductive flow transmitter

2.2 Special Characteristics

Special characteristics of the transmitter:

- Fast signal processing with 16-bit microcontroller
- Automatic recognition of the sensor type and calibration data as result of SmartPLUG
- PROFIBUS-PA (Profile 3.0) or HART communication
- Simple, menu-guided operation with two-line display (optional)
- Self-monitoring function
- Internal simulation for all output functions
- Monitoring of the sensor using magnetizing current and electrode immersion function
- Analog output and digital outputs for pulses, device status, limits, flow direction, frequency output
- Optional switch input for resetting the counter values or for switching off the measuring equipment (PZR)

2.3 Operation

Operation can take place with:

- control and display unit
- HART communicator
- PC/laptop and SIMATIC PDM software by HART communication
- PC/laptop and SIMATIC PDM software by PROFIBUS PA communication

2.4 Technical Data

Application range	see section 2.1
Functional principle	see SITRANS FM sensor
Measuring principle Intermag 2 (7ME5033) Transmag 2 (7ME5034)	magnetic-inductive with pulsed constant field (PDC) pulsed alternating field (PAC)
Magnetic field excitation Intermag 2 (7ME5033) 50/60 Hz AC mains DC power supply	automatic mains synchronization switchable 3, 125/3,75 Hz, 6,25/7,5 Hz, 12,5/15 Hz 3, 6, 12 Hz
Transmag 2 (7ME5034) 50/60 Hz AC mains bipolar bipolar with prepulse unipolar	switchable 16,7/20 Hz 10 /12 Hz 8,33/10 Hz

Outputs and inputs

Electrical isolation	outputs electrically isolated from each other and from the power supply, max. 60 V permissible against PE/PA
<i>For 20 mA / HART devices (7ME503x-0xxxx and -2xxxx)</i>	
Analog output	
Signal range	0 to 20 mA or 4 to 20 mA, can be switched
Upper limit	20 to 22.5 mA
Failure signal	3.6 mA, 22 mA or 24 mA
Load	
Not intrinsically safe output	max. 600 Ω, load voltage max. 15 V,
Intrinsically safe output (7ME5033-0BGxx)	max. 350 Ω, load voltage max. 8,5 V,
For HART communication,	≧ 230 Ω
Communication	via analog output with PC coupling module or HART communicator
Protocol	HART, Revision 5.1
Digital output 1	configurable for positive or negative logic
Signal	
Non intrinsically safe output	configurable active or passive
Active signal	DC 24 V, ≤ 24 mA, Ri = 170 Ω
Passive signal	open collector, max. DC 30 V, 200 mA
Intrinsically safe output (7ME5033-0BGxx)	passive only
Signal	open collector, max. DC 30 V, 100 mA, 750 mW
Output configuration	
Pulse	
Significance	≧ 5000 pulses/s
Pulse width	≧ 0.1 ms
Frequency	≧ 10,000 Hz
Limits	for flow and volume, flow direction, alarm
Digital output 2	
Relay	NC or NO function
Rating	
Non intrinsically safe output	max. 5 W, UC 50 V, 200 mA
Intrinsically safe output (7ME5033-0BGxx)	max. 5 W, UC 30 V, DC 100 mA, AC 50 mA , self resetting fuse, Ri ≤ 9 Ω
Output configuration	limits for flow and volume, flow direction, alarm
Digital input (only alternative to digital output 2), not intrinsically safe	
Input function	configurable high or low active, measured value set to zero or counter reset
Signal voltage	max. 30 V, Re = 3 kΩ
High level	+11 to 30 V
Low level	-30 to +5 V
<i>for PROFIBUS devices (7ME503x-1xxxx)</i>	
PROFIBUS-PA	
Communication	layer 1 and 2 according to PROFIBUS-PA
Transmission system	according to IEC 1158-2
Layer 7 (protocol layer)	according to PROFIBUS-PA and DP V1 (EN 50 170)
Device class	A,
Device profile	3.0; max. 4 simultaneous C2 connections
Bus voltage	
Non intrinsically safe output	permissible 9 to 32 V
Intrinsically safe output (7ME5033-1BGxx)	permissible 9 to 24 V (FISCO supply device)
Current consumption from bus	10 mA, in the event of an error ≤ 15 mA as result of electrical current limiting
Digital output 1	
Passive signal	configurable for positive or negative logic, open collector, max. DC 30 V, 100 mA
Output configuration	
Pulses	
Pulse rate	≧ 5000 pulses/s
Pulse width	≧ 0.1 ms
Full scale frequency	≧ 10,000 Hz
Limits	for flow and volume, flow direction, alarm

Control and display interface

General display	LCD, background illumination, two rows of 16 characters each
Multi-display	for flow, volume, flow velocity, current, frequency
Operation	4 optical elements, hierarchical menu guidance with clear text and code numbers

Measuring accuracy under reference conditions

Pulse output	
at $v > 0.25$ m/s	$\cong 0.5$ % of the measured value, ± 0.0012 m/s
at $v < 0.25$ m/s	$\cong 0.0025$ m/s
Analog output 4 to 20 mA	same as pulse output; plus ± 0.1 % of the measured value ± 20 mA
Reproducibility	0.2 % of the measured value

Reference conditions

Medium temperature	$+25$ °C ± 5 °C
Ambient temperature	$+25$ °C ± 5 °C
Warm-up time	min. 30 min
Installation conditions	
Inlet line	$\cong 10$ x DN
Outlet line	$\cong 5$ x DN; installed centered to pipe
Medium	water without gas and solid parts, > 200 μ S/cm
Magnetic frequency	
Intermag 2 (7ME5033)	12,5 Hz; f/4
Transmag 2 (7ME5034)	bipolar with prepulse (f/5)

Installation conditions

Ambient temperatures	
Intermag 2	
Standard devices (7ME5033-xxAxx)	
Remote design	-20 °C to $+65$ °C
Compact design	-20 °C to $+65$ °C, medium temperature to 60 °C
	-20 °C to $+40$ °C, medium temperature to 130 °C, dependent on measuring tube lining
Devices with explosion protection (7ME5033-xxCxx, -xxDxx and -xxGxx)	Temperature ranges and temperature classes according to section 3.6
Transmag 2 (7ME5034)	
Remote design	-20 °C to $+60$ °C
Compact design	-20 °C to $+60$ °C, medium temperature to $+60$ °C
Control and display unit	$- 0$ °C to $+50$ °C
Storage	-25 °C to $+80$ °C
Degree of protection	IP 67, NEMA 4X, 5
Electromagnetic compatibility (EMC)	
Emitted interference	
Intermag 2 (7ME5033)	according to EN 61236, for use in home and in industry
Transmag 2 (7ME5034)	according to EN 61236, for use in industry
Noise immunity	according to EN 61326/NAMUR NE21, for use in home and in industry

Medium conditions

Medium temperature in compact devices	-20 °C to $+130$ °C, depending on sensor and ambient temperature
Minimum conductivity of the medium	
using SITRANS F M 711/A, 711/E sensors	$\cong 3$ μ S/cm
using 711/S sensor and S1 and S2 probes	$\cong 20$ μ S/cm
using SITRANS F M 711/F5 sensor	$\cong 10$ μ S/cm
using SITRANS F M 911/E sensor	$\cong 0,008$ μ S/cm
using SITRANS FM 911/F5 sensor	$\cong 0,1$ μ S/cm

Construction

Weight of transmitter	4.4 kg
Compact versions	transmitter permanently mounted on measuring tube
Remote version	transmitter connected to the sensor by a shielded cable
Maximum line length	100 m; 15 m using sensors without SmartPLUG
Housing	die-cast aluminum
Electrical Connection	
Compact version	2 x M20 or 1/2"-NPT
Remote version	same as compact version + 2 x M16 or 1/2"-NPT

Construction (contd.)

- Assembly
- Compact version
- Remote version

transmitter already fitted on measuring tube
 stainless steel mounting plate for wall mounting,
 optionally for wall and pipe mounting
 according to rating plate

Power supply

- Intermag 2 (7ME5033)
- AC voltage

AC 100 to 230 V, $\pm 15\%$ (85 V to 265 V), 47 to 63 Hz or
 AC 24 V, $+10/-15\%$ (20,4 bis 26,4 V), 47 to 63 Hz
 DC 24 V, $+25/-20\%$ (19,2 bis 30 V)
 approx. 10 W

- DC voltage
- Power consumption
- Transmag 2 (7ME5034)
- AC voltage
- Power consumption
- Power failure

AC 100 to 230 V, $\pm 15\%$ (85 V bis 265 V), 47 bis 63 Hz
 120 to 630 VA, dependent on measuring tube
 bypass of at least 1 mains period (> 20 ms)

2.5 Control and display unit

External operation without tools is possible with the control and display unit. There is not need to open the device. This means that the high degree of protection of IP 67 is guaranteed at all times.

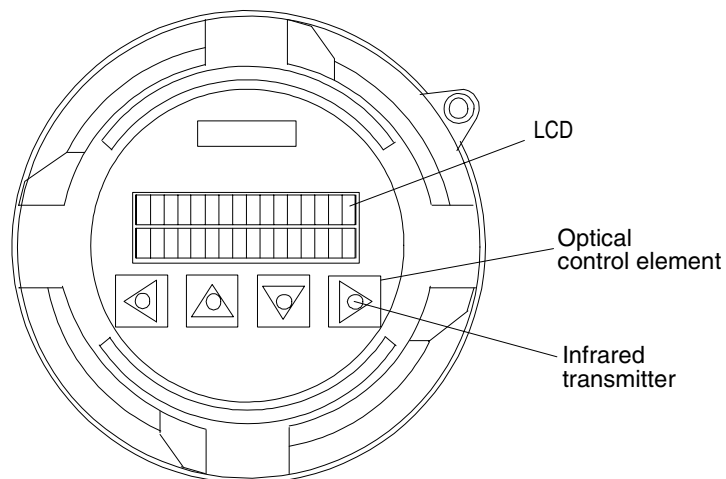

Figure 2-2 Control and display unit of the SITRANS FM InterMag 2

The individual functions and parameters are selected using a hierarchically structured, multi-language input menu with four optical input elements. The parameters can be specifically selected and modified using alphanumeric text and code numbers, e.g.:

- Operating parameters such as measuring range, physical dimensions or device information
- Limits for flow, counter configurations
- Noise suppression using separate interference suppression and damping as well as hysteresis functions
- Automatic mains synchronization
- Display parameters (freely-configurable text display)
- Display in volume or mass units
- Density as constant input value for conversion of volume into mass
- Zero flow cut-off
- Forward and reverse flow measurements
- Flow direction display and evaluation
- Diagnostics functions and control values
- PROFIBUS address
- Functions of analog output: proportional flow, failure signal
- Functions of digital output 1 (transistor): pulse output, frequency output proportional to flow, alarm, forward or reverse flow signal, min. or max. limit for flow and counter
- Functions of digital output 2 (relay): alarm, forward or reverse flow signal, min. or max. limit for flow and counter
- Simulation of output signal via analog output, digital output 1 and digital output 2
- Option: digital output 2 as digital input for resetting counter values or for interruption in measurement (PZR)

The HART protocol is superimposed on the analog output (current output). This communication capability permits parameterization of the device using the HART communicator or a PC/laptop and SIMATIC PDM software in addition to local operation.

In the SITRANS F M InterMag 2/TransMag 2 version with PROFIBUS-PA, the analog output and the digital output 2 are replaced by the digital PROFIBUS-PA output. Parameterization of the device is then possible using PROFIBUS communication and SIMATIC PDM in addition to local operation.

2.6 Ordering Data

Ordering data

SITRANS FM

Magnetic-inductive flow transmitter

Flow transmitter InterMag 2 for constant field
Flow transmitter TransMag 2 for alternating field

Output/communication

0/4 to 20 mA with HART protocol
PROFIBUS PA
0/4 to 20 mA with HART protocol and digital input

Power supply

AC 100 to 230 V
UC 24 V ³⁾

Explosion protection ³⁾

with explosion-protection marking
II 2 G EEx de [ia] IIC T3/T4/T6
II 2 G EEx dem [ia] IIC T3/T4/T6
II 2 G EEx dem [ia] IIC T3/T4/T6

Terminal box
explosion proof
increased safety
increased safety

Signal outputs
not intrinsically safe
not intrinsically safe
intrinsically safe ²⁾

Control and display unit

Without
With

Design

Remote design
Compact design

Cable glands

M20/M16 x 1.5
1/2"-NPT

Order number

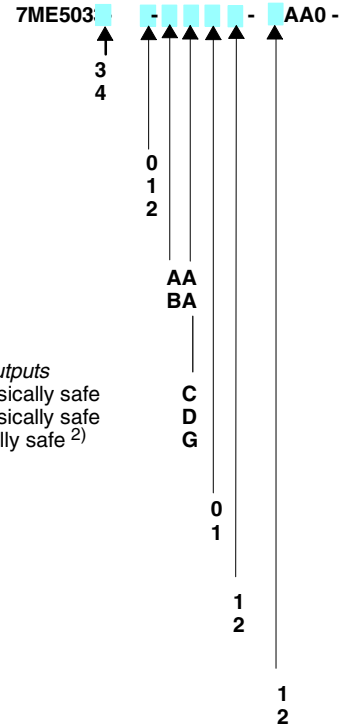

Other models

Please add **•-Z•** and code to the order number

Code

Rating plate inscription in English

B11

Specify measuring range in plain text:

Y01: e.g.: 0 to m³/h

Y01

Specify pulse significance in plain text:

Y02: e.g.: 0 to pulses/l

Y02

Setting of digital outputs, specify in plain text:

Y03: Setting of the digital outputs

Y03

Measuring-point number (max. 8 characters), specify in plain text:

Y15:

Y15

Measuring-point description (max. 16 characters), specify in plain text:

Y16:

Y16

Stainless steel tag plate

Y17

Accessories

Reinforced mounting bracket for wall and pipeline mounting

A02

¹⁾ not with devices with intrinsically safe outputs (7ME5033-xBGxx)

²⁾ only with auxiliary power 24 V (7ME5033-xBGxx)

³⁾ only with InterMag 2 (7ME5033)

2.7 Dimensions

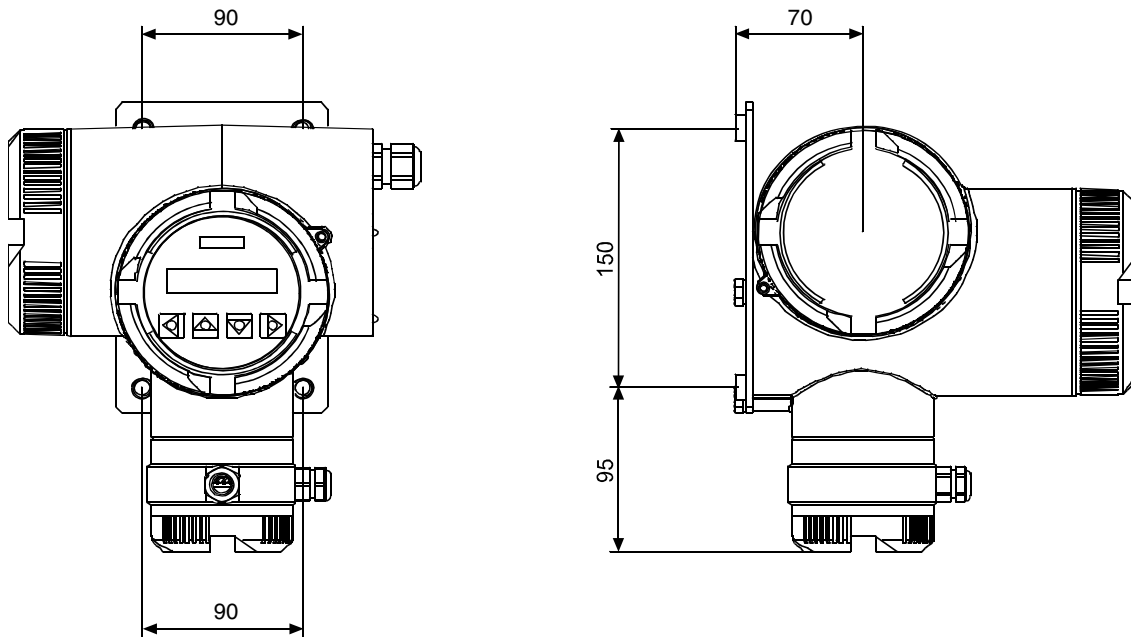

Figure 2-3 SITRANS FM InterMag 2/TransMag 2 transmitter (remote design) with standard mounting plate, dimensions

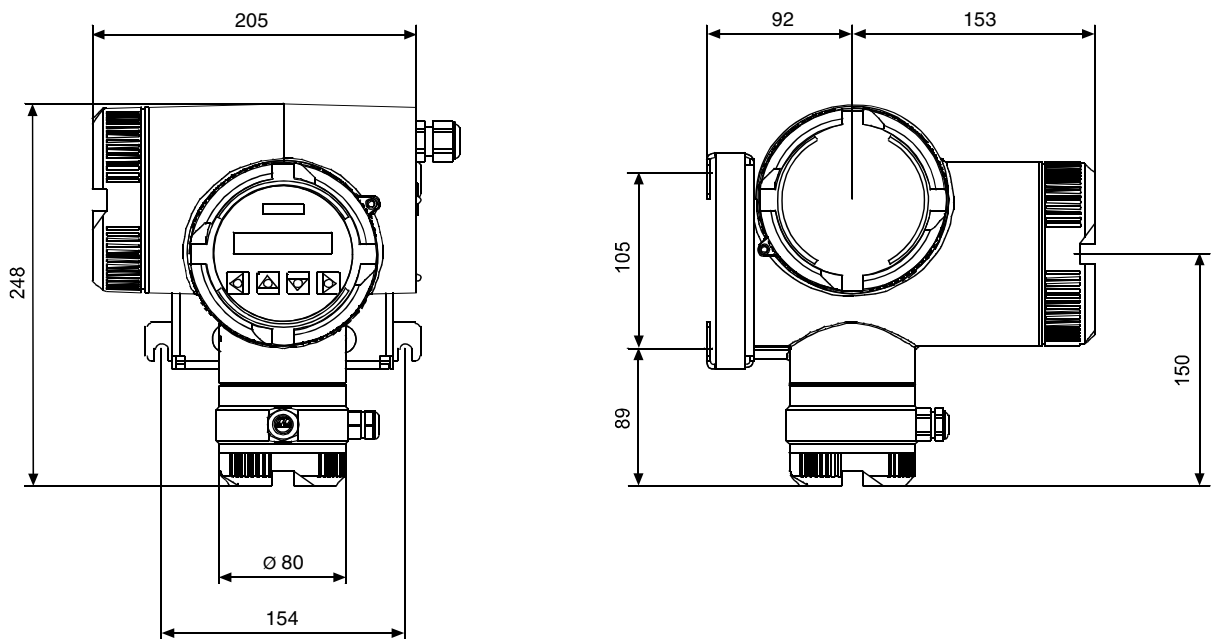

Figure 2-4 SITRANS FM InterMag 2/TransMag 2 transmitter (remote design) with optional mounting plate for pipeline mounting, dimensions

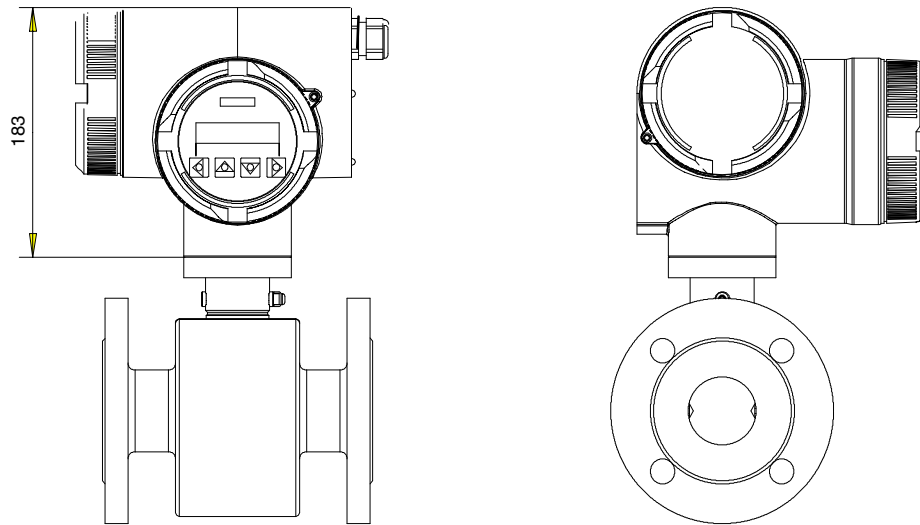

Figure 2-5 SITRANS FM InterMag 2/TransMag 2 transmitter in compact design

Installation

3

3.1	General Information	3-2
3.2	Installation in Pipelines	3-2
3.2.1	Potential equalization (reference potential)	3-2
3.2.2	Sensor	3-3
3.2.3	Probes	3-6
3.2.4	Accessories	3-6
3.3	Control and Display Unit	3-7
3.4	Electrical Connection	3-8
3.4.1	General Information	3-8
3.4.2	Connection of the Power Supply	3-10
3.4.3	Connection of the signal cables	3-10
3.4.4	Connection of the magnetic current and electrode line (remote version only)	3-12
3.4.5	Connection of the 711/A, 711/E (remote version) and 911/E Sensors	3-17
3.4.6	Connection of the 711/F5 and 911/F5 Sensors	3-18
3.4.7	Connection of the 711/S sensor and the S1 and S2 probes (Intermag 2 only)	3-19
3.5	Assembly of the remote version	3-20
3.5.1	Assembly with standard mounting plate	3-20
3.5.2	Assembly with assembly bracket for pipe and wall mounting	3-21
3.6	Special information for devices with explosion protection	3-22

3.1 General Information

A magnetic-inductive flow measuring device is made up of the following components:

- a SITRANS F M Intermag 2/Transmag 2 transmitter and
- a SITRANS FM 711, 911 series sensor or S1 or S2 probes

These components are either connected directly with each other in a compact version or separately from each other in a remote version.

Installation of these components is described in this chapter. Make sure the measuring device is protected from direct sunlight when installing it outdoors.



Warning

These devices meet the requirements of IP 67 degree of protection. Proper installation is a prerequisite for compliance with this degree of protection. Please observe the operating steps and instructions in this chapter.

The maximum permissible ambient and medium temperatures must be observed at all times.

The information in section 3.6 is to unconditionally observed for devices with explosion protection.



Caution

If the surface of the sensor or sensor tube can get hotter than 50 °C in the application, fire protection and/or a warning sign must be provided.

3.2 Installation in Pipelines

3.2.1 Potential equalization (reference potential)

The sensor must be at the same potential as the medium for an accurate measurement. This is guaranteed when the connecting flange of the pipe is made of metal and a perfect electrical connection is established to the sensor through the fastening screws. In this case the medium, pipe and transmitter are connected with each other in the sense of a potential equalization. In the case of internally electrically isolated pipes, the medium in the pipe must be applied to a reference potential by additional measures (e.g. by grounding rings).

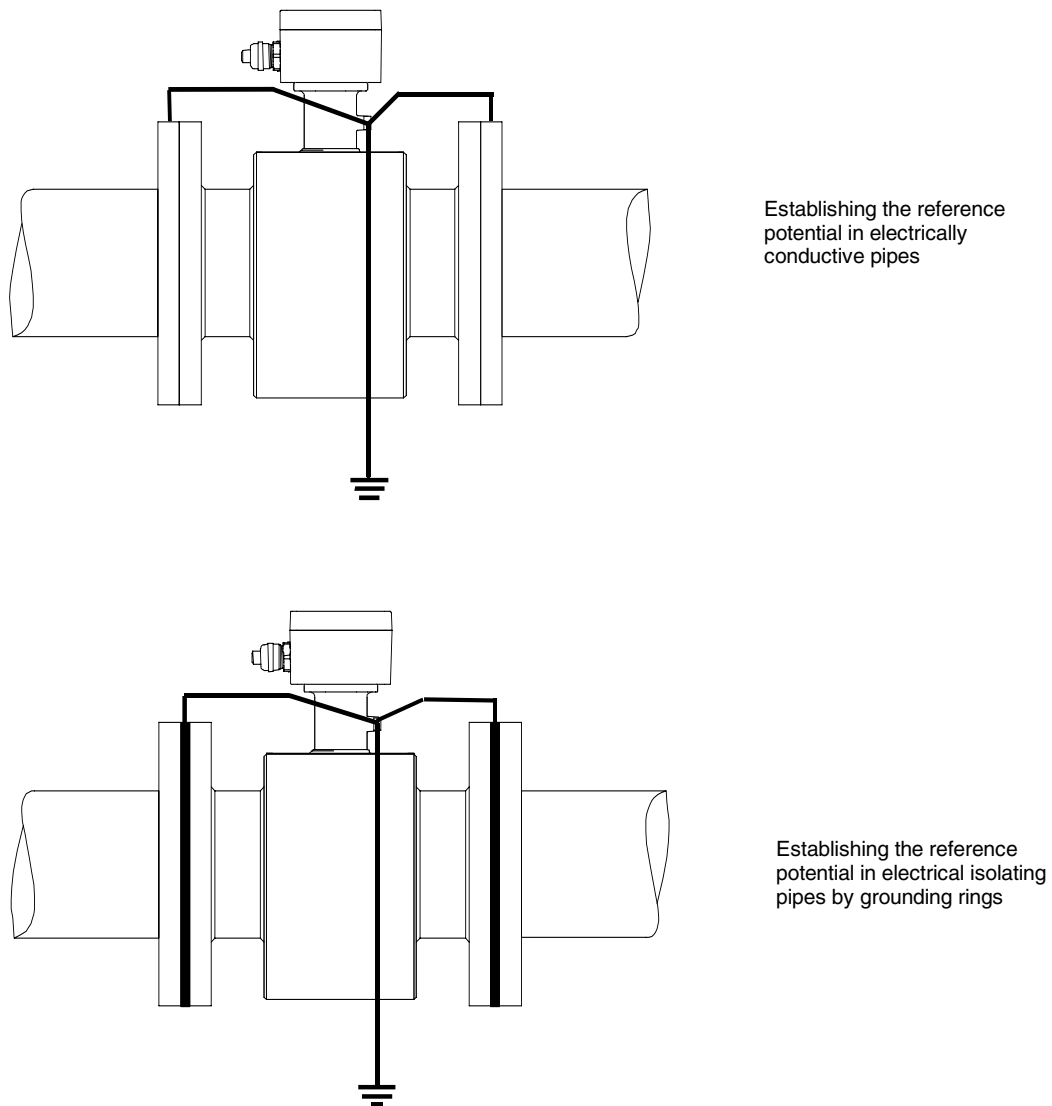

Figure 3-1 Potential equalization

3.2.2 Sensor

Please observe the following instructions when installing the SITRANS F M 711/911 sensor in a pipe:

The measuring principle is generally independent of the flow profile unless static eddy currents penetrate the measured value forming zone (e.g. after pipe elbows, in the case of tangential occlusion or half open

slides in front of the sensor). Measures to normalize the flow profile are necessary in such cases. Suitable measures in this respect are:

- increasing the inlet and outlet lines
- using flow rectifiers
- reducing the line cross section

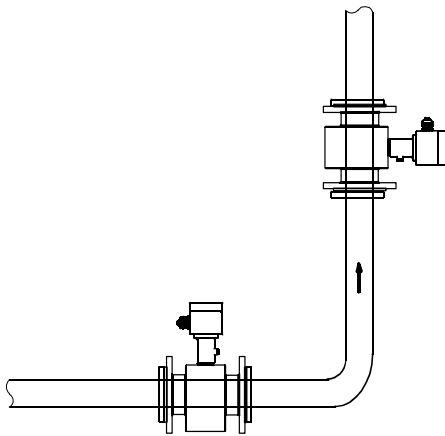

Installation may be horizontal or vertical (Figure 3-2) but you must make sure that the axes of the electrodes run horizontally (the direction arrow marks the electrode axes) to avoid measuring errors due to deposits or air bubbles on the electrodes.

Figure 3-2 Installation in Horizontal and Vertical Pipelines

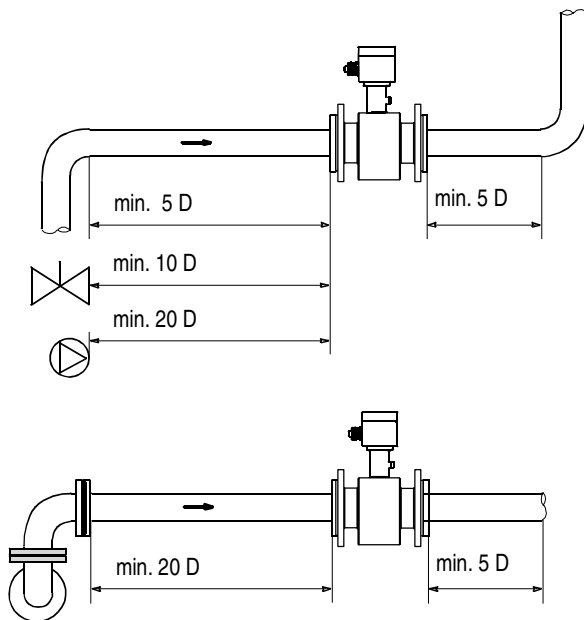

The inlet and outlet lines must be kept straight

Figure 3-3 Installation between pipe elbows, valves and pumps

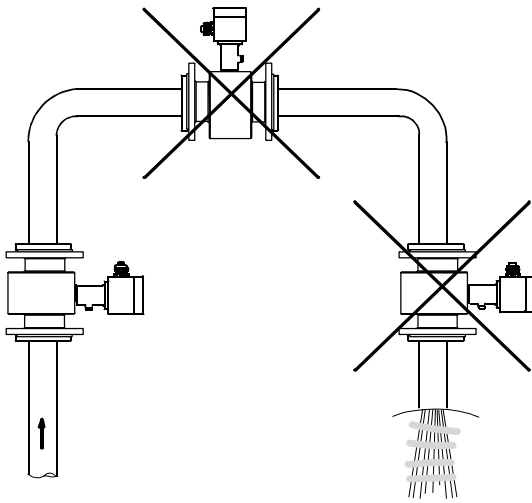

The sensor should not be installed in pipe sections with a free pipe outlet which could run empty. When installing in a downpipe, make sure that the pipe is always filled 100% with the medium.

Figure 3-4 Installation in pipes without emptying

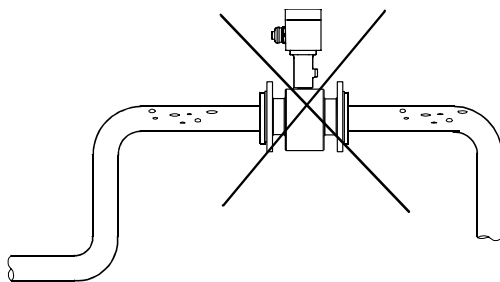

Avoid installation at the highest point of the pipe because of accumulation of gas

Figure 3-5 Installation at the highest point

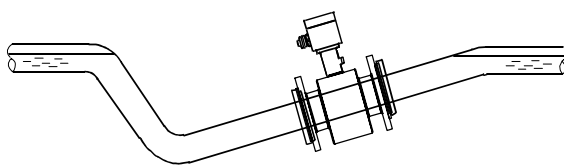

The flow measuring device must be installed so that the measuring pipe cannot run empty and is always filled with medium. The sensor must be installed in a culvert in the case of an unfilled pipe or only a free level line (outlet).

Figure 3-6 Installation in a constantly filled pipe

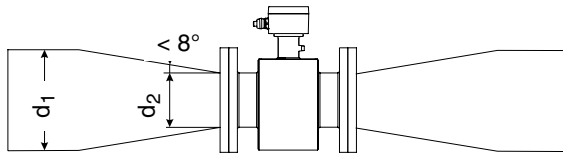

By reducing line cross sections you have the possibility of installing smaller sensors in pipes of larger rated widths. This has the advantage that the speed in the sensor increases with small flows and thus a better measuring accuracy is achieved.

To avoid the formation of eddy currents in the sensor, the angle of reduction should not be greater than 8° .
You also have to note that reductions cause losses in pressure.

Figure 3-7 Example of reduction of a line cross section

3.2.3 Probes

The S1 and S2 probes can be connected to the SITRANS FM InterMag 2.

A data sheet in which you can read the appropriate installation instructions is enclosed with these probes.

3.2.4 Accessories

Protective discs, grounding rings and protective rings (orifice protectors) are offered as accessories.

The protective discs are fitted permanently as a standard on all PTFE-coated sensors to protect the coating.

Protective rings (orifice protectors) protect the inlet and outlet edges of the sensor against mechanical damage especially when used with corrosive media.

Grounding rings serve to establish the reference potential of the sensor in electrically isolating pipes.

3.3 Control and Display Unit

The control and display unit can be turned in 90° steps to enable better reading in the case of vertical installation or overhead assembly.

Proceed here as follows:

- Switch off the power supply.
- Release the catch on the lid of the electronics compartment with a 3 mm Allen key.
- Unscrew the cover.
- Carefully release the fastening hooks of the control and display unit using a screwdriver or similar tool
- Then pull it out, turn it to the desired position and push it back in.
- Screw the lid back on and mount the lid catch.

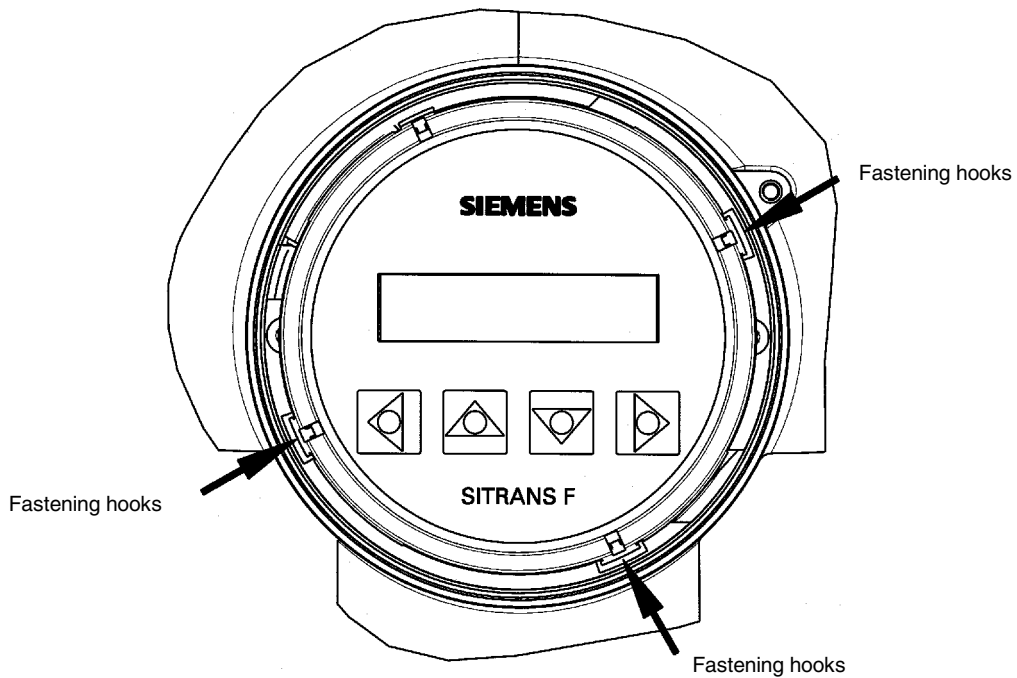

Figure 3-8 Unlocking the fastening hooks on the control and display unit

3.4 Electrical Connection

3.4.1 General Information



Warning

The pertinent regulations must be observed for electrical installation.

**Never install the device with the mains voltage switched on !
Danger of electric shock!**

The electrodes and magnetic current line may only be connected when the device is not connected to the power supply.

Please note that the version for the UC 24 to 30 V power supply may only be connected to SELV or PELV circuits.

Housing covers may only be unscrewed by **qualified personnel** when the housing is under voltage (power supply).

Handling devices with explosion protection you must pay particular attention to all information in section 3.6.

The SITRANS FM magnetic-inductive measuring devices comply with the following protection classes:

- Version for 100 to 230 V AC: Protection class I
- Version for UC 24 to 30 V: Protection class III

It generally applies for electrical installation:

- Only use heat-resistant cables if high temperatures occur on the housing, e.g. due to heat conductance from the sensor/measuring pipe. Lay the cables so that they do not touch the hot sensor tube.

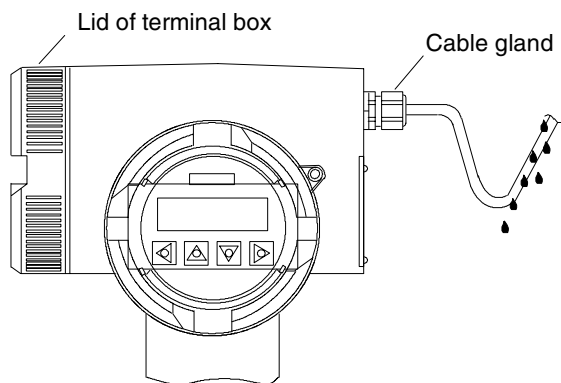

Figure 3-9 Example of laying cables before connecting the lines

- Note that you may only use cables with at least the same degree of protection as the sensor to install the sensor.
- The line length from the cable gland to the terminals must be kept as short as possible, line loops in the terminal box must be avoided.
- To guarantee the IP 67 degree of protection, please use cables with the following external diameters:

Auxiliary power and signal cable (large terminal box):

Cable gland	permissible external diameter		
	Standard devices 7ME503x-xxAxx	Terminal box explosion-proof 7ME5033-xxCxx	Terminal box in increased safety 7ME5033-xxDxx 7ME5033-xxGxx
M20 x 1,5	6 - 12 mm	8 - 11,7 mm	5 - 9 mm
1/2" - 14 NPT	6 - 12 mm	6 - 12 mm	6 - 12 mm

Magnetic field current and electrode cable (small terminal box, only remote model):

- Cable glands M16 x 1.5 6 to 10 mm
- Cable glands 1/2" NPT 5 to 9 mm
- Connect the cables as follows:
 - Release the catch on the lid of the terminal box using a 3 mm Allen key (only devices with a 100 to 230 V AC power supply and devices with explosion protection type EEx de).
 - Unscrew the lid of the terminal box.
 - Push the supply cable and signal cable through the cable glands up to the terminal strip. Lay the cable in a loop before the cable glands so that moisture does not get inside the terminal box (Figure 3-9).
 - Connect the lines according to Figure 3-11 through Figure 3-13. Fit end ferrules to fine-wire lines.
 - Tighten the cable gland and check strain relief.
 - Screw the lid to the housing and tighten it. You must not use any tools. The sealing ring must be clean and undamaged.
 - Mount the lid catch.
 - For transmitters in remote design, also connect the housing to the local potential equalization to which the appropriate sensor must also be connected.

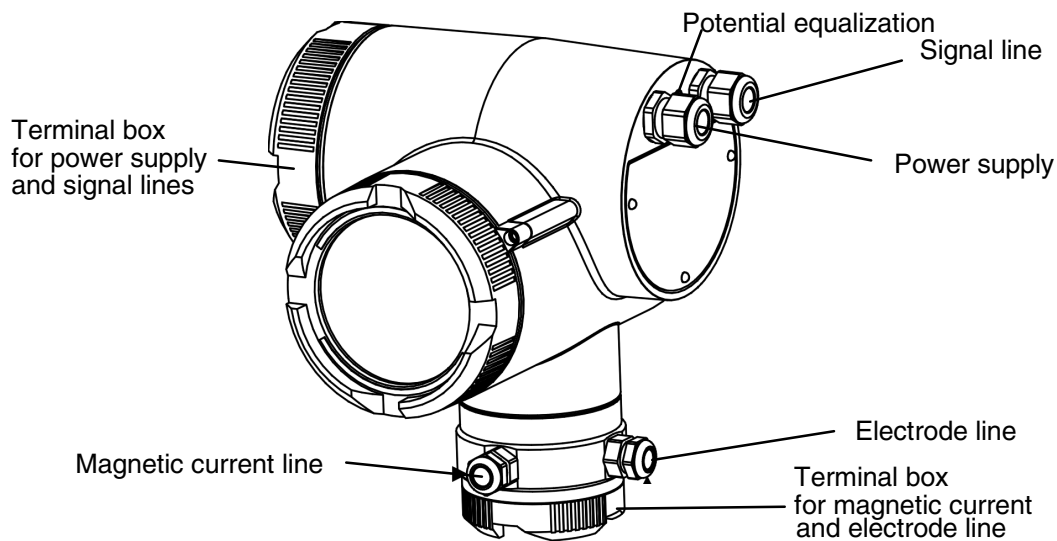

Figure 3-10 SITRANS FM InterMag 2/TransMag 2, electrical connections

3.4.2 Connection of the Power Supply

- Only connect the device to the supply which matches the specifications on the rating plate.
- Connect the power supply by an easily accessible and appropriate labeled isolating device and fuse (max. 4 A) or an easily accessible circuit breaker (max. 4 A).
- Use cables with a cross section of at least 1.5 mm² and double or reinforced insulation for the power supply.
- Connect the PE conductor of the power supply to the ground terminal \oplus in the terminal box. The line length must be dimensioned so that the PE conductor comes away last when the cable is pulled.

3.4.3 Connection of the signal cables

- Lay the signal cables separately from cables with voltages > 60 V.
- In a wet environment, the signal cable for digital output 2 (terminals 3 and 4) must be isolated when the feed-in voltage is more than AC 16V / DC 35 V.
- Only use signal cables with twisted wire pairs.
- Avoid laying signal cables close to large electrical installations or use - if possible - only shielded cables.

- The full HART 5.1 specification only applies when using shielded cables.
- Use signal cables with twisted wire pairs if the analog output and pulse/frequency output are used simultaneously and signals are transmitted in one cable.
- A load of at least 230 Ω must exist in the signal circuit (see also technical data) for error free communication via the HART protocol.

When connecting to PROFIBUS also observe the following points:

- Only use shielded cables for the PROFIBUS connection. The Siemens 6XV1 830-5BH10 (black) cable type is recommended. Any connection polarity is possible. The shield must be laid to cover **all** assigned terminal boxes, distributors up to the coupler or link.
- The cable shield must have good contact with one of the grounding clamps above the connection terminals.
- To ensure trouble-free communication, the PROFIBUS must have a bus terminator at both ends. This is usually already provided by the coupler or link at the control system end. An additional bus terminator must be fitted at the remote bus end.

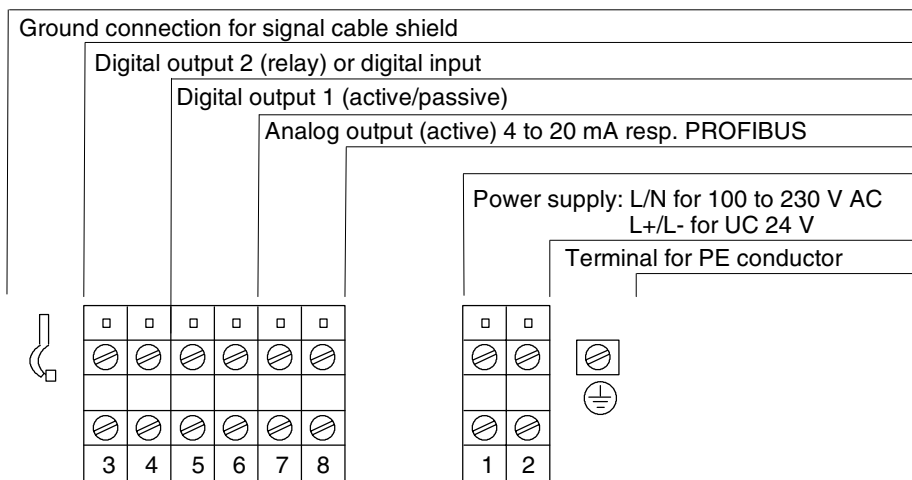

Figure 3-11 Connection diagram for power supply and signal cables

- The total maximum current consumptions of all devices connected to the bus may not exceed the current bearing capacity of the bus feeder. You should therefore plan a reserve for the value of the maximum increase in current caused by a failure of one of the devices connected to the bus.

In SITRANS F M InterMag 2/TransMag 2 the increase due to failure is electronically limited to a maximum 5mA.

You will find general information about the PROFIBUS installation in the Brief Technical Description /1/.

3.4.4 Connection of the magnetic current and electrode line (remote version only)

There are two types of terminal arrangements: An earlier version 1 (see Figure 3-12) and a newer version 2 (see Figure 3-13).

When connecting the sensor cable to the transmitter, make sure that the order numbers on the transmitter rating plate and the sensor rating plate are identical.

The transmitter and the sensor have been calibrated together. Incorrectly paired sensors and transmitters can cause a deviation in the measured value outside the limits of the calibration certificate. This does not affect the principle function of the device. In such cases, you can make corrections with the menu 6.6/6.7.

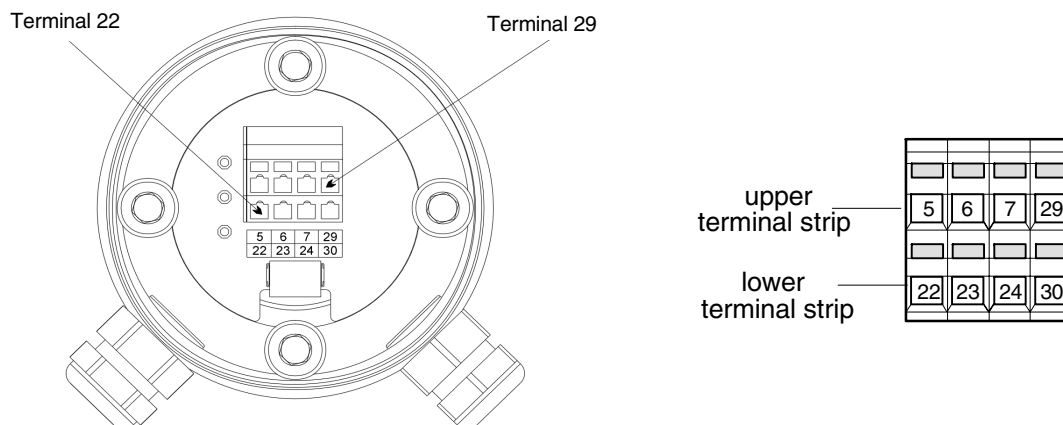

Figure 3-12 Connection diagram for sensor cable (variant 1, InterMag 2 only)

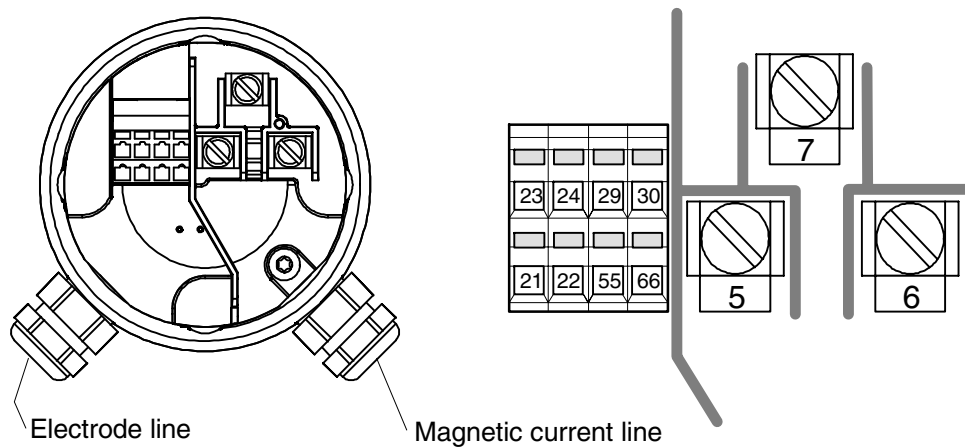

Figure 3-13 Connection diagram for sensor cable (variant 2)



Warning

The SITRANS F M Transmag 2 transducer (7ME5034) may only be connected to measuring sensors for alternating fields SITRANS F M 911/E and 911/F5 .

The magnetic circuit carries dangerous mains voltage.

As long as the device is under voltage, the lid of the housing on the sensor connection area may only be opened by **qualified personnel**.

Before removing the terminal cover, the auxiliary power must be switched off from all poles.

Following installation, the terminal cover must be screwed back on again.

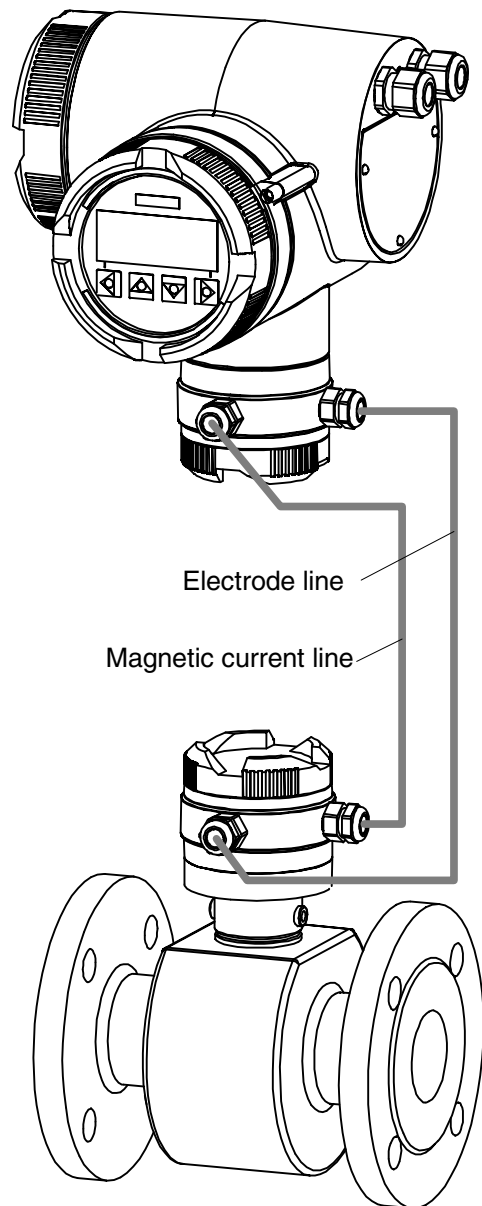

Figure 3-14 Signal transmission from the sensor to the transmitter

Attention!

The sensors have the same terminal names, the lines must be connected 1:1.

Terminals 55 and 66 are used only with Transmag 2 transmitters. With sensors with IP68 degree of protection, the cable colors or the identification tag on the sensor cables must be observed.

Table 3.1 Sensor terminal assignment

Terminal	Designation	Cable color for sensors with IP68 degree of protection	
5	Magnetic field current 1	brown	Magnetic field current cable
6	Magnetic field current 2	white	
7	Potential equalization/PE	green-yellow	
29	SmartPLUG supply (-5 V)	green ¹⁾	Electrode cable
22	Measuring ground	red	
23	Electrode 1	brown	
24	Electrode 2	white	
30	SmartPLUG-supply (+5 V)	blue ¹⁾	
55	Reference voltage 1 (only for Transmag 2)		
66	Reference voltage 2 (only for Transmag 2)		

¹⁾ only for sensors with SmartPLUG

The magnetic power cable must be shielded and fitted with a wire gauge of at least 3 x 1.0 mm². For the Transmag 2 (7ME5034), the cable must be of a suitable dimension for the connected mains voltage. The protective conductor must be marked green-yellow, and must be connected such that it is the last cable to come loose when pulled.

The electrode cable (including the SmartPLUG supply voltage) must also be shielded and should have a wire gauge of 5 x 0.5 mm² (Intermag 2) or 7 x 0.5 mm² (Transmag 2), (e.g. LIYCY).

Prepare the cable before connection as shown in Figure 3-15.

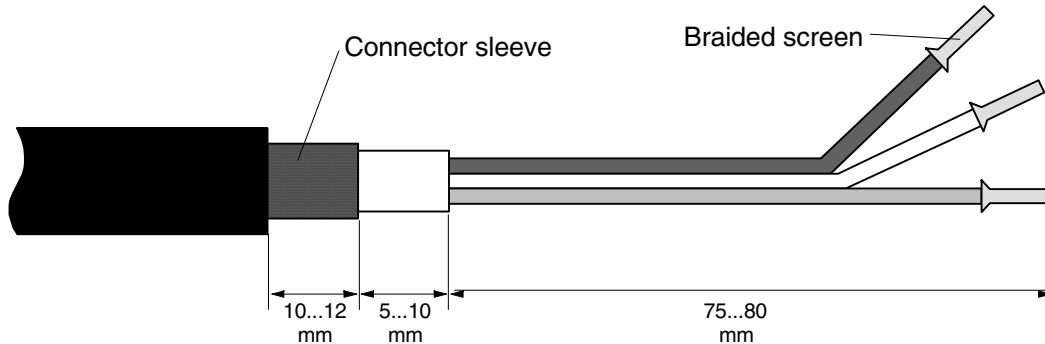

Figure 3-15 Preparation of the electrode and magnetic field current cable

To guarantee the IP 67 degree of protection, please use cables with the following external diameters:

- Cable glands M16 x 1.5 5 to 10 mm
- Cable glands M20 x 1.5 5 to 9 mm
- Cable glands 1/2"-14 NPT 6 to 12 mm

The sensor cable shield is connected to the transmitter and sensor as follows (see Figure 3-16):

- Bend the cable shield back over the clamping piece of the cable gland.
- Push the clamping piece with the sensor cable into the threaded bush of the cable gland turning it slightly to the right.
- Tighten the lock nut on the threaded bushing until the cable is connected tightly (IP 67).



Note !

The SmartPLUG is a pre-amplifier in the sensor with integrated data module which contains the stored factory data of the sensor and customer-specific data.

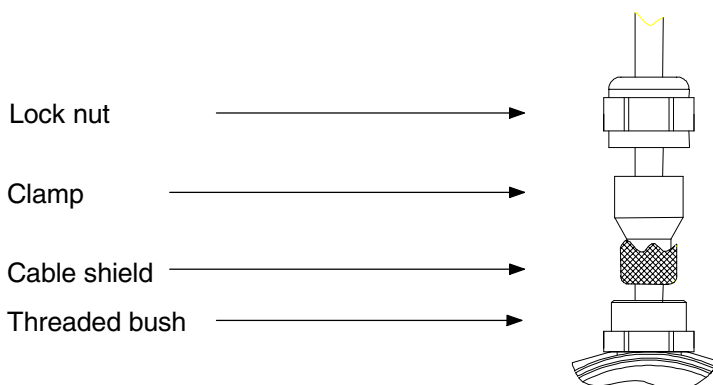

Figure 3-16 Sensor cable shield

3.4.5 Connection of the 711/A, 711/E (remote version) and 911/E Sensors

The 711/A and 911/E remote version measurement sensors have a terminal box as shown in Figure 3-17 (variant 1) or Figure 3-13 (variant 2). The 711/E measurement sensors have a terminal box as shown in Figure 3-17.

Terminals 55 and 66 are used only with Transmag 2 transmitters.

Feed the electrode line through the left gland and the magnetic current line through the right gland and connect the cables as drawn in Figure 3-17 (variant 1) or Figure 3-13 (variant 2).

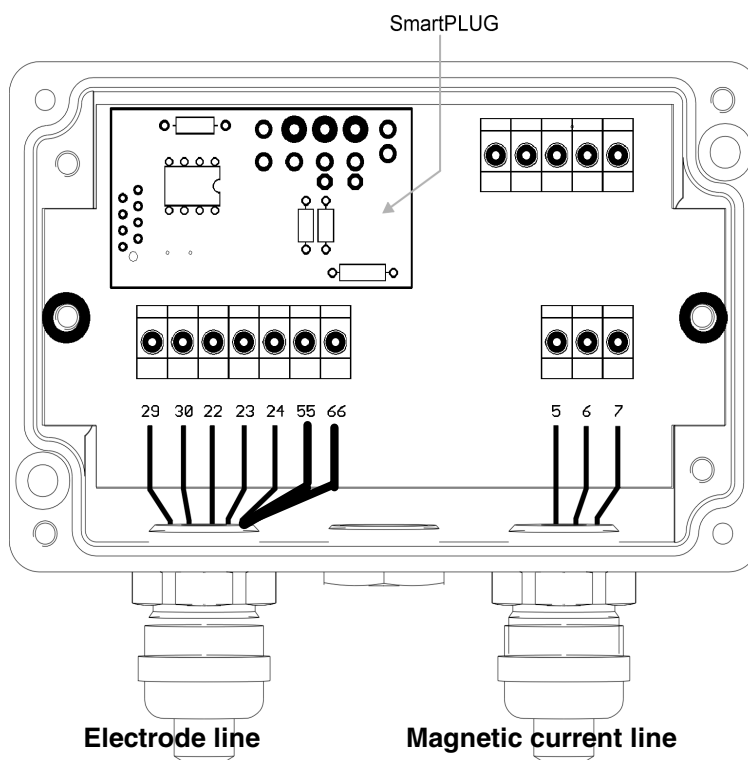

Figure 3-17 Electrical connections of the 711/A, 711/E and 911/E sensors (variant 1)

Older sensors of the same type have no SmartPLUG. There is therefore no need for the connections to terminals 29 and 30.

3.4.6 Connection of the 711/F5 and 911/F5 Sensors

Feed the electrode line through the PG screw-type gland drawn in Figure 3-18 and the magnetic current line through the PG screw-type gland drawn in Figure 3-19. Please note that older sensors of the same type have no SmartPLUG. There is therefore no need for the connections to terminals 29 and 30. Terminals 55 and 66 are only assigned for Transmag 2.

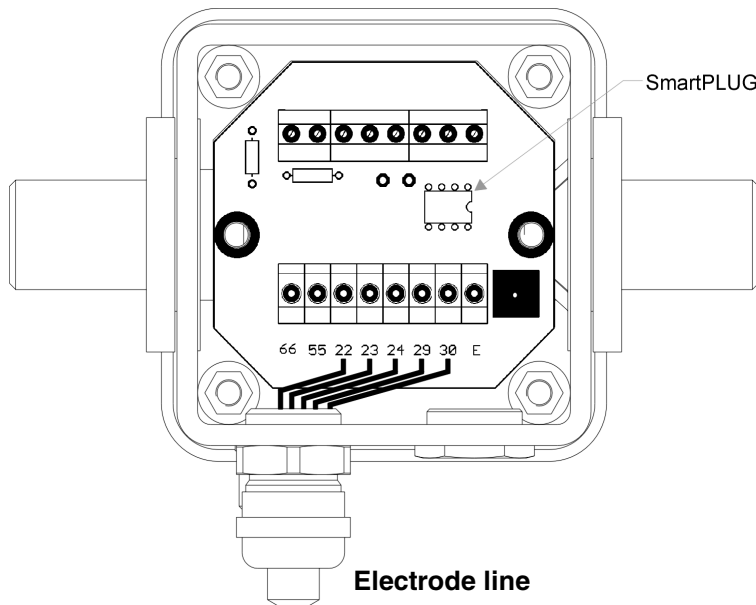

Figure 3-18 Electrical connections of the 711/F5 sensor (bottom)

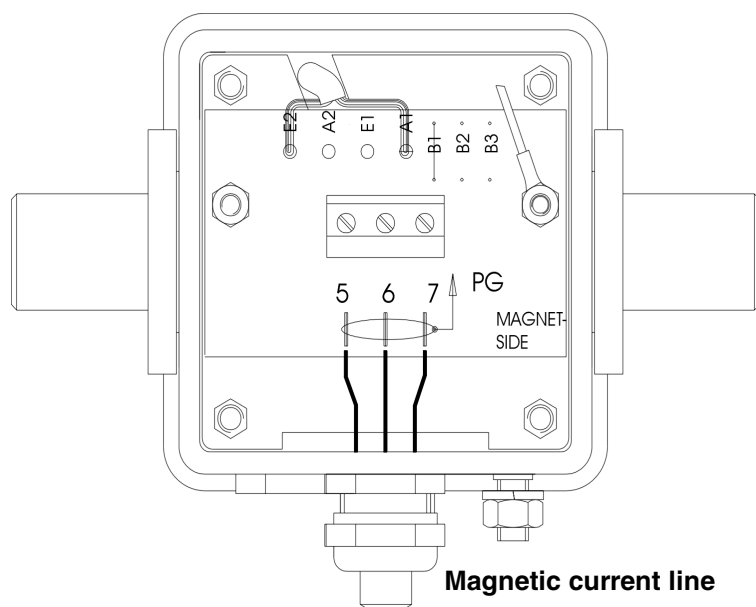

Figure 3-19 Electrical connections of the 711/F5 sensor (top)

3.4.7 Connection of the 711/S sensor and the S1 and S2 probes (Intermag 2 only)

These sensors are equipped with a pre-assembled cable ex-factory. This cable is permanently connected to the sensor at one end. The end leading to the transmitter is fitted with a cable gland and pre-prepared cable ends for connection. The attached wire numbers serve for orientation.

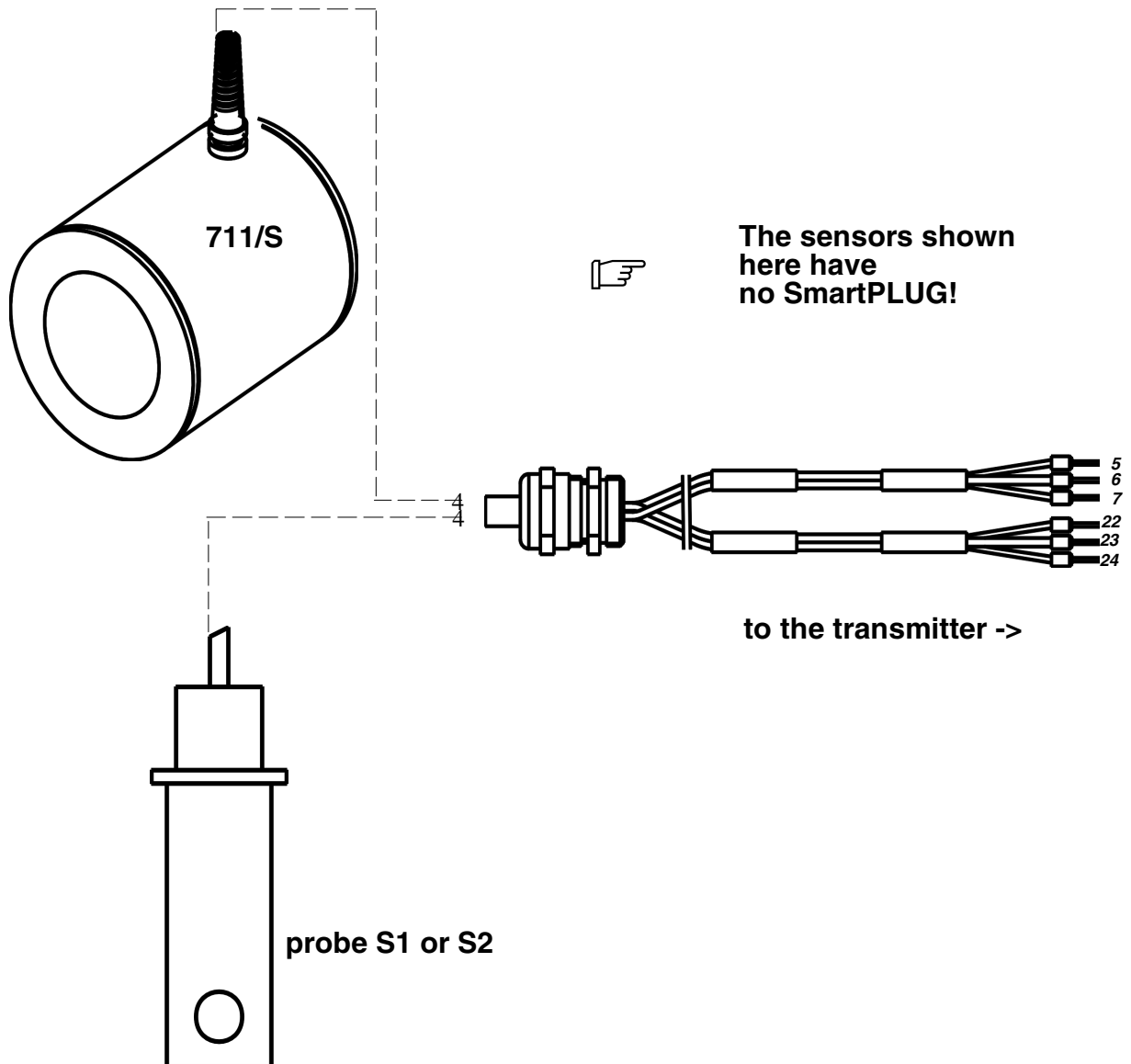

Figure 3-20 Connections of the 711/S Sensor and the Probes



Note !

No potential equalization is necessary for the 711/S sensor because this sensor has integrated grounding discs.
The installation instructions in the data sheet must be observed for the probes S1 and S2!

3.5 Assembly of the remote version

3.5.1 Assembly with standard mounting plate

The standard mounting plate is only suitable for wall mounting. It should be fitted to the transmitter with the mounting material provided before mounting on the wall.

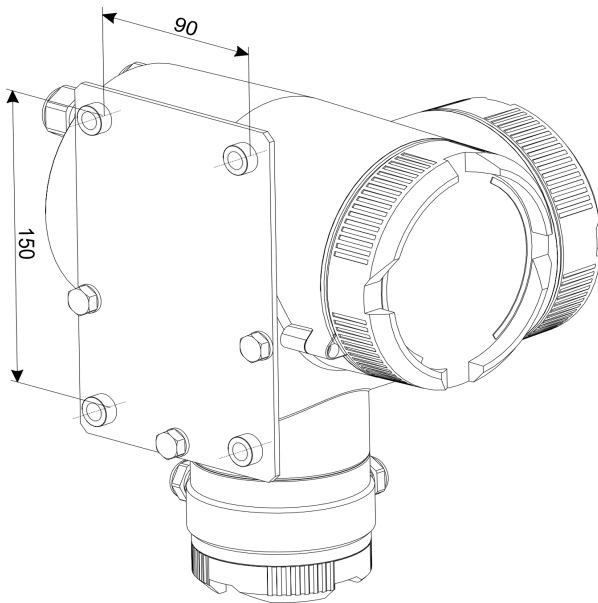

Figure 3-21 Sensor with standard mounting plate

3.5.2 Assembly with assembly bracket for pipe and wall mounting

The assembly bracket is suitable for both pipe and wall mounting.

Pipe assembly

In pipe assembly the assembly bracket is mounted on the pipe with both fastening brackets first. Then the transmitter can be fastened with the two screws provided.

Wall mounting

In wall mounting, the assembly bracket is screwed directly to the back of the transmitter before mounting on the wall. The fastening brackets and nuts are not needed for wall mounting.

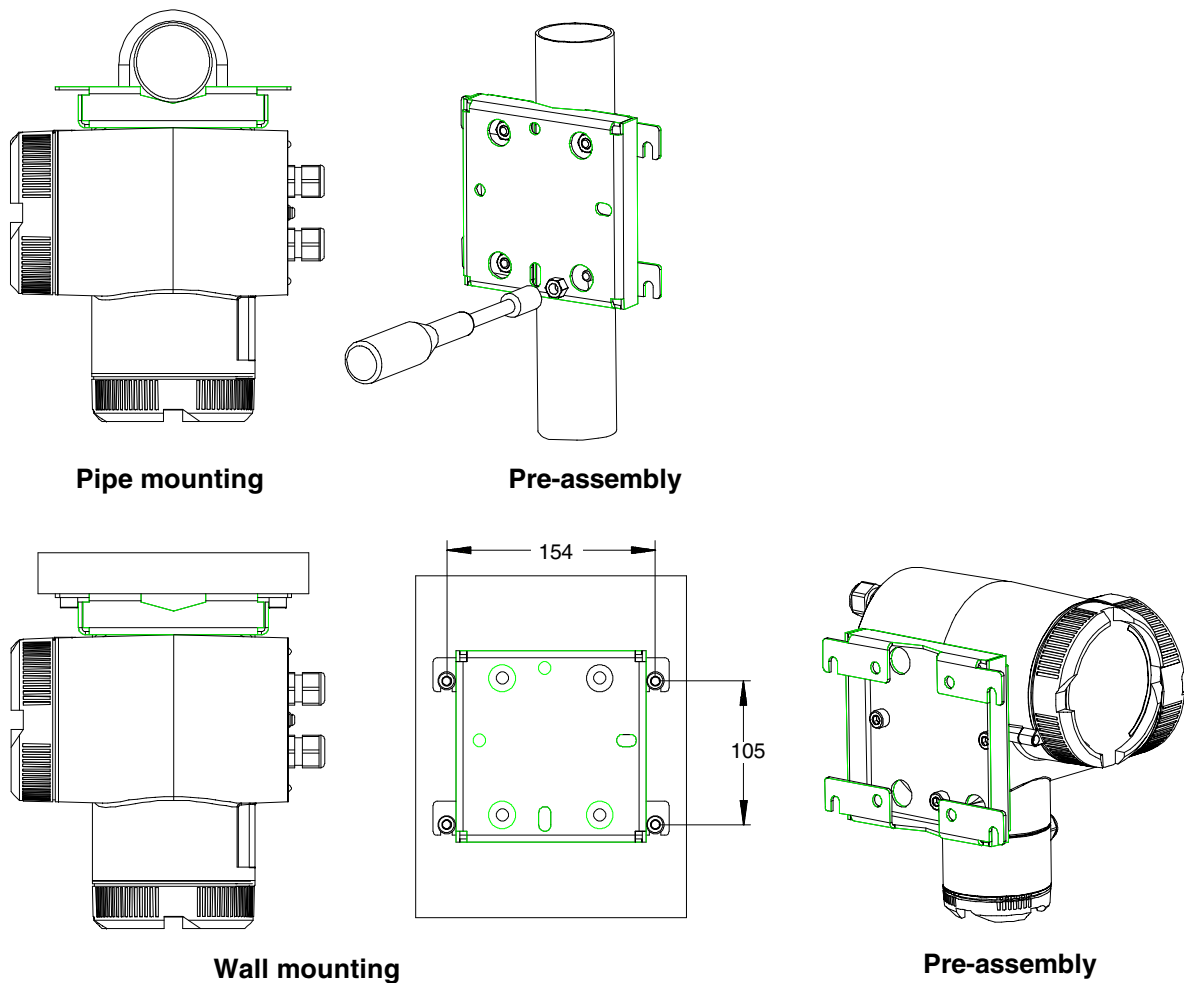

Figure 3-22 Mounting possibilities for the assembly bracket

3.6 Special information for devices with explosion protection

The variants 7ME5033-**C** , -**D** and -**G** are category 2G devices for use in zone 1.

The electronics compartment of these devices is fundamentally explosion-proof. The terminal box for auxiliary power and signal outputs is available either as explosion-proof version or version with increased safety. The signal outputs are optionally not intrinsically safe or intrinsically safe (only in connection with 24 V supply).

The sensor connection contains an electric circuit with increased safety and two intrinsically safe electric circuits [ia].

The EU type examination certificate (see appendix - chapter 7) must be observed. Please pay also attention to the regulations and specifications for the installation and operation of systems in hazardous areas valid in your country.

Using remote models, measuring transducers and sensors must be connected via an adequate equipotential bonding. The outer terminals on the measuring transducer housing or on the housing flange of the measuring sensor are designed for this purpose.

The supply lead of the auxiliary power must be protected with an external fuse with a max. 4 A and an interrupting potential of 1500 A.

All cables to the measurement sensor as well as the cable glands on the measurement sensor must be rated for a temperature of at least +85°C. At ambient temperatures of less than 40 °C around the measurement sensor, a temperature rating of +70 °C is considered as adequate.

Unused cable glands for the explosion protection type EEx e must be sealed with certified blind plugs. With measuring transducers of explosion protection type EEx de [ia] (7ME5033-**C**), unused cable glands may only be replaced by screw plugs. Use only cable glands or screw plugs which are certified for explosion-proof enclosures.

Output circuits of devices with intrinsically safe signal outputs (7ME5033-**G**) may only be connected with certified intrinsically safe devices or barriers. The devices connected must be incorporated in the equipotential bonding of the measuring transducer. The permissible maximum values for current, voltage, power, connectable capacity and inductance specified in the EU type examination certificate (appendix in chapter 7) must be unconditionally observed.

If the device is live (auxiliary power or external current of the signal outputs), the housing cover may not be unscrewed in hazardous areas.

With devices with explosion protection type EEx dem [ia] (7ME5033-****D**** and 7ME5033-****G****), the cover of the terminal box for auxiliary power and process outputs may also be opened when live for testing purposes. The cover over the terminals for the auxiliary power (terminals 1 and 2) may not be removed. Only certified testing devices may be used for testing.

The allocation of the temperature classes takes place depending on media and ambient temperature and the nominal size:

Remote version:

Ambient temperature -20 to +60 °C: Temperature class T6

Compact version:

When nothing else is specified, an upper temperature limit of the measuring medium of +90 °C (values in brackets) always applies for measurement sensors with a vulcanized rubber lining.

Nominal size	Ambient temperature -20 to +40 °C permissible media temperature in °C			Ambient temperature -20 to +60 °C permissible media temperature in °C	
	T6	T4	T3	T4	T3
DN 15 to 80	-	109 (90)	130 (90)	60	60
DN 100 to 150	65	125 (90)	130 (90)	60	60
DN 200 to 300	80	130 (90)	130 (90)	60	60

The measurement sensors can be used in zone 1. An explosive mix under atmospheric conditions (pressure: 0.8 to 1.1 bar; temperature: -20 to +60 °C) may only occur in the measuring tube for a short period of time, e.g. when filling and emptying.

The measuring tube should be filled exclusively with media to which the seal and lining materials are chemically resistant (see order description of the measurement sensor). Only conductive media are permissible (minimum conductivity: 3 µS/cm).

Commissioning

4

4.1	Safety Instructions	4-2
4.2	Preparations for Commissioning	4-2

4.1 Safety Instructions



Warning

Certain parts inside the device carry dangerous high voltage. The housing must be closed and grounded before switching the device on.



Warning

The sensor connected to this device can be operated with high pressure and corrosive media. Therefore serious injuries and/or considerable material damage cannot be ruled out in the event of improper handling of the device.

4.2 Preparations for Commissioning

After switching on the power supply, the device runs a self-test which last about 30 seconds.

If the sensor has a SmartPLUG, the factory data of the sensor as well as essential customer-specific tag data (range, units for flow and totalizers, flow limit values, medium density, operating language) are transferred to the transmitter the first time you switch on. The tag data can then be changed permanently in the transmitter. These data are not read in again until a new sensor is connected.



Note !

When replacing with the **Intermag 1** transmitter you only have the **flow units** of the SITRANS FM **Intermag 2** transmitter according to the *3.1.1* menu item at your disposal.

Other units are automatically converted into similar units of the SITRANS FM Intermag 2.

All data for configuring the signal outputs are not taken from the sensor in the SITRANS FM Intermag 2 and must always be set on the transmitter.

The measuring system is then immediately ready for operating and starts measuring automatically.

Other application-related settings can be found in table 5-1 in section *3.2.1*).

If the sensor does **not** have a SmartPLUG, such as the SITRANS FM 711/S type, the probes S1 and S2 or older sensor types such as 711/A and -/E, you have to make the following settings to establish the measuring function:

Menu item 5 - Identification		
Menu code	Parameters	Setting value
5.2.6.1	Nominal diameter	See nameplate of the sensor
	Diameter	Only after 'Probe' is selected: enter the actual interior diameter of the surrounding tube!

The nominal diameter must be entered **before** the measuring range!

Menu item 3 - Measuring function		
Menu code	Parameters	Setting value
3.1.1	Unit ¹⁾	
3.1.2	Flow URV	any value in the 0.25 - 12 m/s range

¹⁾ If Mass flow is selected in the 3.1.1 menu, you must enter the density additionally in the 3.1.4 menu.

Menu item 6 - Service		
Menu code	Parameters	Setting value
6.7.2	CFH	See nameplate of the sensor
	CFR	See the nameplate of the transducer, only necessary for Transmag 2 (7ME5034)
6.7.3	ZPH	See nameplate of the sensor
6.7.4	Excitation frequency	according to Table 5-4

In older versions of **sensors** the calibration constant is known as "C100" and must be converted with the formula

$$CFH = (0,035343 * DN^2) / C100 \quad (DN = \text{nominal diameter in mm})$$

into a CFH value.

In older versions of **Transmag analog sensors** the calibration constant is known as "R100" and must be converted with the formula

$$CFH = (176,715 * DN^2) / R100 \quad (DN = \text{nominal diameter in mm})$$

into a CFH value.

In **probes** the probe constant "C1" must be converted with the formula

$$CFH = 1250 / C1$$

into a CFH value!

The ZPH value must be set to 0 in both cases!

The measuring system is now ready to start measuring. We recommend you to enter your personal code after entering these parameters in the 6.2 menu in order to prevent parameters being changed by third (unauthorized) persons.

Gas/air in the line

If there is still gas/air in the measuring tube or in the pipeline after assembly, a flashing "F" appears at the top of the first line in the display (see also menu item "2.1 Device status" in section 3.2.1). The failure signal is output at the analog output and for the digital outputs an error message is output if they are programmed for this function. The flowing medium removes the gas/air occlusions from the tag and the flow can be measured without interference after a few minutes.

Operation

5

5.1	General Information	5-2
5.2	Operating concept of the control and display unit	5-4
5.2.1	Operating elements	5-4
5.2.2	Disabling or enabling the programming	5-6
5.2.3	Operating examples	5-6
5.2.4	Setting options and factory setting	5-9
5.3	Device Functions and Parameters	5-23
5.3.1	Function Group Display	5-23
5.3.2	Function Group Diagnostics	5-25
5.3.3	Function Group Measuring Functions	5-27
5.3.4	Function Group Device Outputs	5-35
5.3.5	Function Group Identification	5-42
5.3.6	Function Group Service	5-43
5.4	PROFIBUS Communication	5-47
5.4.1	Cyclic Data Traffic	5-48
5.4.1.1	Input Data (from Slave to Master)	5-48
5.4.1.2	Output Data (from Master to Slave)	5-51
5.4.1.3	Device Database File (GSD)	5-51
5.4.2	Acyclic data traffic	5-52
5.4.3	Diagnostics	5-53
5.4.4	Locking operation	5-56

5.1 General Information

You can operate this device in the following ways:

- with the control and display unit
- via the HART communicator (in preparation)
- with a PC/laptop and SIMATIC PDM software

You will find the electrical connection of the PC/laptop and the HART communicator to the 4-20 mA signal line in Figure 5-1.

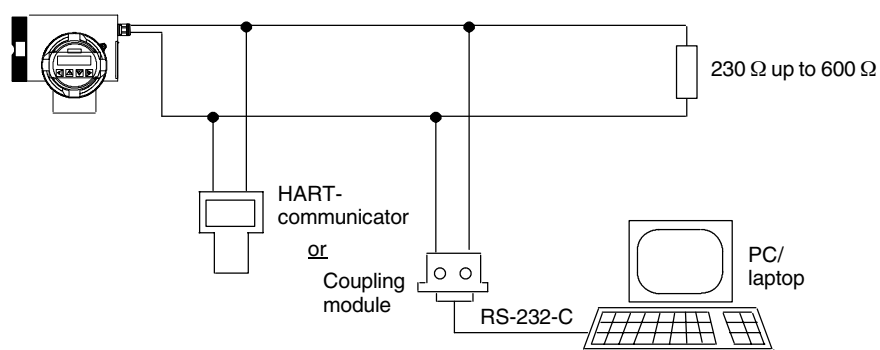

Figure 5-1 Electrical connection, schematic diagram

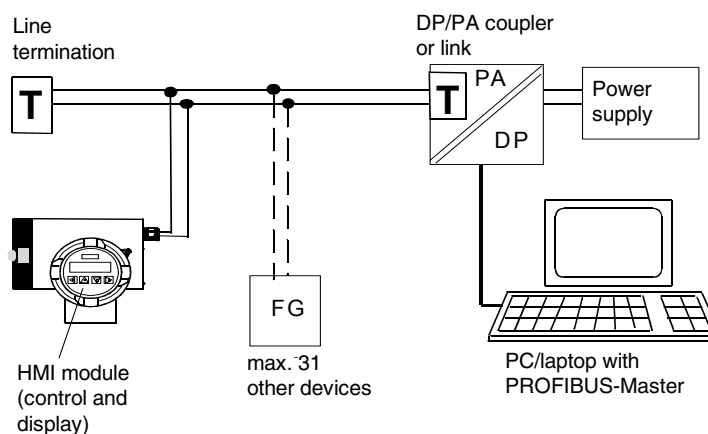

Figure 5-2 Connection for PROFIBUS communication, schematic diagram!

The PC must have the following minimum equipment to operate via SIMATIC PDM:

Hardware:

- Pentium processor or higher
- at least 32 MB RAM
- Hard disk with at least 110 MB free capacity
- Monitor: VGA standard or compatible with MS-Windows
- Keyboard and (optional) mouse
- CD-ROM drive
- Interface CP5411 A2 or CP5511 or CP5611

Software:

- Windows98, Windows NT4.0 or Windows2000
- SIMATIC PDM V5.01 or higher (SIMATIC STEP 7 OEM included)
Operation of SIMATIC PDM is supported by integrated help functions.

You can operate the device with the optical elements on the control and display unit (Figure 5-3). You actuate these by touching the glass panel above the appropriate operating element. You will find a clear text display above these operating elements which gives you a menu-guided operation of the individual device functions/parameters when you actuate the operating elements alternately.

The exact structure of the operating menu is explained in section 5.2 by the control and display unit.

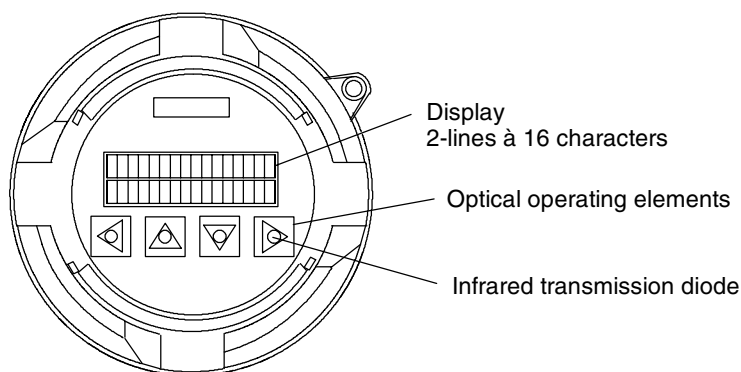

Figure 5-3 control and display unit

5.2 Operating concept of the control and display unit

Operation is based on a hierarchically structured operating concept, i.e. all functions/parameters are grouped logically and carry a menu code (Figure 5-4).

The first (top) level is the main menu. You can select one of the four function groups here.

- 1 Displays
- 2 Diagnosis
- 3 Measuring functions
- 4 Device inputs and outputs
- 5 Identification
- 6 Service

The individual functions and parameters for further groups are combined under these main groups.

5.2.1 Operating elements

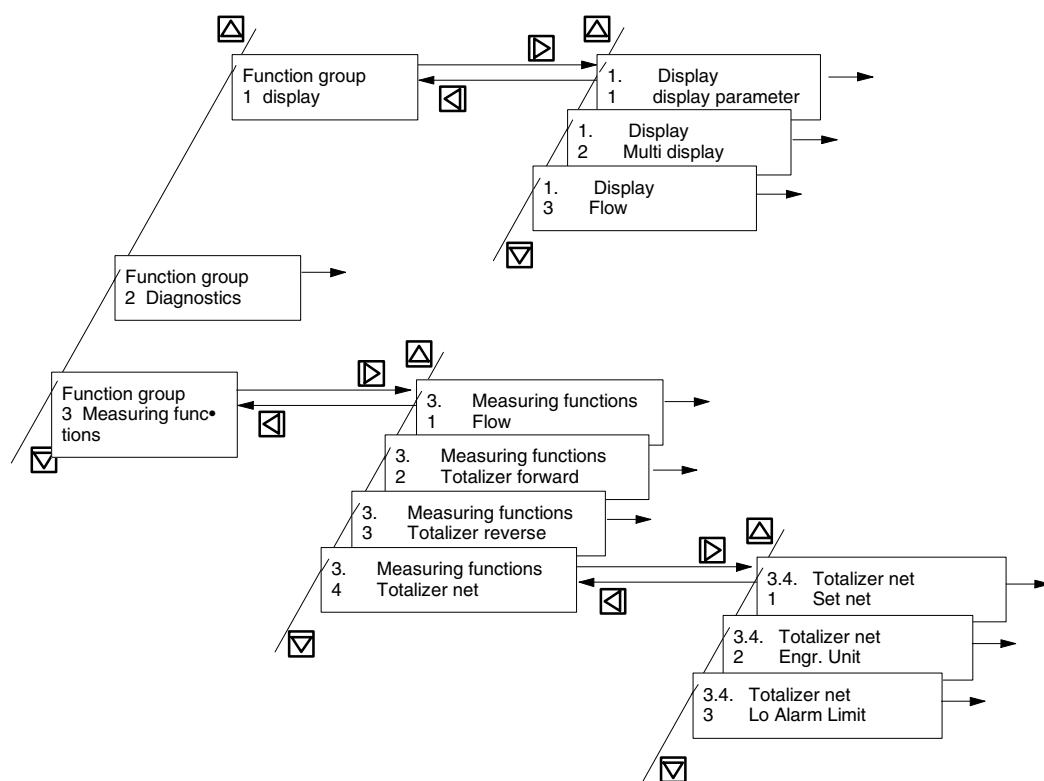











Figure 5-4 Operation structure (excerpt)

The available device functions and parameters are shown in the second line of the display. You can select them there with the  and  operating elements. You can scroll in the selected device function or setting level of the parameters (Enter function) with . It is possible to exit the selected function or setting level to the level above with .

The currently valid setting appears after selecting the setting level of a parameter. The programmable value flashes in the second line of the display when programming is enabled (section 5.2.2). You can change the parameter setting in this position. You have to decide between the following types of input to enter data.



- Direct numeric input
- Input from given table

In the numerical input, the  and  operating elements have the function of a cursor control. The selected digit flashes. You can now set the desired digit or move the point to the right or left with the  and  operating elements. Digits are input with carry over to the next highest place. After selecting the last digit you terminate the input by pressing the  operating element. The entered value is accepted if it is within the permissible input range. In this case the user guidance returns to the selection menu for the parameters of the group concerned. If the entered value is rejected, an error message briefly appears on the display and then the previous setting. You can then change it again.

In section 5.2.4 you will find an overview of all the functions and parameters with factory setting and setting options.





Note !

If the  and  operating elements are kept actuated (with your finger continuously on the glass panel) the numeric value or setting option is changed continuously when using the tabular selection. A numeric input carries over to the next highest position.

If you want to prevent an accidentally changed setting from becoming active, you can exit the menu item by pressing the  operating element several times (return to the operating level above).

5.2.2 Disabling or enabling the programming

The control and display unit can be disabled to prevent unauthorized manipulation by entering a freely selectable, personal code number. The device functions and parameters can only be changed after entering this code in this case. You define the personal code number in the "6.2 Customer code" menu item.

If you actuate the  and  operating elements in the parameter setting level, the display prompts you to enter the code. You can also enter the code number in the "6.1 Enter Code" menu item. The programming is disabled again:

- after returning to display mode
- about 10 minutes after pressing the last operating element
- after entering any number not the same as the code number in the "6.1 Enter Code" menu item



Note !

With code = 0 (factory setting), the programming is **always** enabled. You can always disable the operation by HART communication.

5.2.3 Operating examples

Example 1 The engineering unit for the current flow value should be changed from m^3/h to l/min . The starting point is the multi- display.

The operating path to be executed is shown semibold in this diagram (Figure 5-5). The operating elements to be actuated are specified and the individual operating steps numbered consecutively.

The following display appears after completing the data input (8th operating step)

3.1. Flow
1 Engr. Unit

You return to the initial position by actuating the operating element  three times.

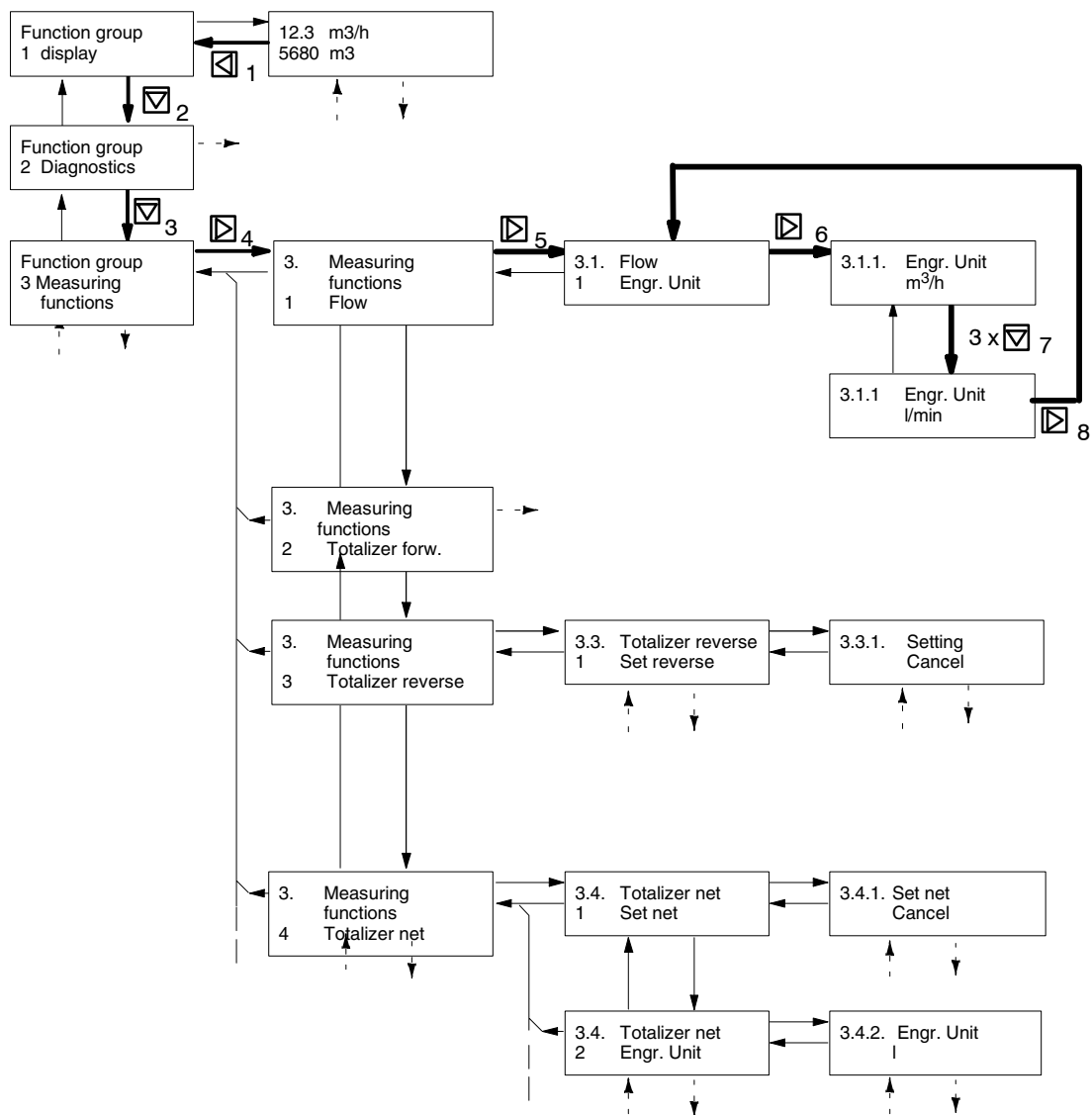

Figure 5-5 Diagram for example 1

Example 2 The pulse valency is to be changed from 1 pulse per liter to 200 pulses per liter.

The menu item 4.2.3 "Pulse valency" is selected as described in section 5.2.4, page 5-15.

The currently valid setting appears in the display.

4.	2.		D	i	g	i	t	.	o	u	t	p	u	t	1
3			P	u	l	s	e		r	a	t	e			

Enable the programming.
The unit in the second display line flashes.

↓ 1 x

4.	2.	3	U	n	i	t									
			I	m	p	/	l								

Digit 1 flashes.

↓ 1 x

4.	2.	3	P	u	l	s	e		r	a	t	e			
+	1	.	0	0		I	m	p	.	/	U	n	i	t	

You change the digit from 1 to 2 with the operating element

↓ 1 x

4.	2.	3	P	u	l	s	e		r	a	t	e			
+	2	.	0	0		I	m	p	.	/	U	n	i	t	

You select the point with the operating element.

↓ 1 x

4.	2.	3	P	u	l	s	e		r	a	t	e			
+	2	.	0	0		I	m	p	.	/	U	n	i	t	

You move the point two places to the right by pressing the operating element twice.

↓ 2 x

4.	2.	3	P	u	l	s	e		r	a	t	e			
+	2	0	0	.	0	0	I	m	p	.	/	U	n	i	t

Select the last position of the number with and terminate the input by pressing the operating element (Enter function).

↓ 3 x

4.	2.		D	i	g	i	t	.	o	u	t	p	u	t	1
3			P	u	l	s	e		r	a	t	e			

Figure 5-6 Diagram for example 2

5.2.4 Setting options and factory setting

The device functions and the parameters are listed below with the factory setting and setting option. The menu code only appears in the display of the control and display unit.

Menu code	Device function, Parameters	Description	Factory setting	Setting options
1. Display				
1.1	Display Param.	Setting parameter for the local display		
1.1.1	Language	Language for user guidance	deutsch	Englisch, deutsch, français, italiano, español, nederlands
1.1.2	Line 1	Definition of measured values to be displayed for line 1 in multi-display	Flow	Flow, Totalizer net, Flow velocity, Analog Val. ^{1, 2} , Frequency
1.1.3	Line 2	Definition of measured values to be displayed for line 2 in multi-display	Totalizer net	Flow, Totalizer net, Flow velocity, Analog Val. ^{1, 2} , Frequency
1.1.4	Display flow	Selection for type of presentation of the flow rate (% and bargraph only apply to line 2) When the "Flow" parameter has been selected for lines 1 and 2, "Bargraph in %" is always shown in line 2.	Engineering Unit	Engineering Unit, %, bargraph in %
1.1.5	LCD lighting	Lighting of the display On: permanently switched on Off: automatic switch on by pressing key, switch off after 10 min.	Off	On, Off
1.2	Multi-Display	Simultaneous display of two measuring variables	(actual measured value line 1 1) (actual measured value line 2)	Menu 1.1.2 Menu 1.1.3
1.3	Flow	Flow value	(actual measured value)	

¹ Parameters apply only to devices with 20 mA/Hart communication and digital output 2

(7ME503x-0xxxx)

² Parameters apply only to devices with 20 mA/Hart communication and digital input

(7ME503x-2xxxx)

Menu code	Device function, Parameters	Description	Factory setting	Setting options
1.4	Totalizer	Flow quantity since totalizer start; volume or mass, depending on selected unit (menu 3.1.1)	(actual totalizer reading)	
1.4.1	Total. forward	Forward flow only	(actual totalizer reading)	
1.4.2	Total. rev.	Reverse flow only	(actual totalizer reading)	
1.4.3	Total. net	Flow difference forward - reverse	(actual totalizer reading)	
1.4.4	Set (all)	Reset all totalizers simultaneously to zero and stop or start; (separate setting of totalizers, see menu 3.2.1, 3.3.1, 3.4.1)	Cancel	Reset+Stop, Reset+Start Cancel
1.5	Flow Velocity	Flow velocity in measuring tube in m/s	(actual measured value)	
1.6	Frequency	Calculated frequency value for actual flow in Hz	(actual measured value)	
1.7	Analog Out ^{1, 2}	Calculated current value for actual flow in mA	(actual measured value)	

- ¹ Parameters apply only to devices with 20 mA/Hart communication and digital output 2 (7ME503x-0xxxx)
² Parameters apply only to devices with 20 mA/Hart communication and digital input (7ME503x-2xxxx)
³ Parameters apply only to devices with PROFIBUS communication (7ME503x-1xxxx)

Menu code	Device function, Parameters	Description	Factory setting	Setting options
2. Diagnostics				
2.1	Device status	Device status, error messages	("OK" or error messages)	
2.2	Electr.Check	Supervision of electrodes in sensor	Inactive	Active, Inactive
2.3	EmptyTube Det.	Time interval for immersion check of electrodes or deactivation of immersion check. In case of insufficient immersion of both electrodes in conductive medium, 'Tube empty' is reported under device status.	Inactive	Inactive, 15 s, 30 s, 60 s, 120 s, 300 s
2.4	Device Test			
2.4.1	Self Test	Check device status (duration approx. 60s)		
2.4.2	Display Test	Visual check of local display		
2.5	Simulation			
2.5.1	Flow Value Time	Simulation of a flow value; effects all outputs, totalizers, limit values and display. "F" flashes in the top right of the display during simulation and "Simulation" is displayed under device status. Simulation value in % of full scale value Duration of simulation After expiration of this time or with input of "End" the normal measuring mode is resumed	0 % End	-110% to +110% End, 10 min, 30 min, 60 min
2.5.2	Dig. Out.1	Simulation of output signal at the digital output 1	End	End, 0.1 Hz, 1 Hz, 10 Hz, 100 Hz, 1 kHz, 10 kHz, Alarm on, Alarm off
2.5.3	Dig. Out.2 ¹	Simulation of the output signal at the digital output 2	End	Alarm on, Alarm off
2.5.4	Analog Out. ^{1, 2}	Simulation of the output signal at the analog output	4 mA	0 mA, 4mA, 10mA, 12mA, 20mA, failure signal

¹ Parameters apply only to devices with 20 mA/Hart communication and digital output 2

(7ME503x-0xxxx)

² Parameters apply only to devices with 20 mA/Hart communication and digital input

(7ME503x-2xxxx)

Menu code	Device function, Parameters	Description	Factory setting	Setting options
3. Meas.Functions				
3.1	Flow			
3.1.1	Engr. Unit	Engineering unit for volume flow or mass flow When you select a unit of mass flow (see right column), you must enter the actual medium density (menu 3.1.4).	DN 2 ... 12: l/h DN >12: m ³ /h	m ³ /s, m ³ /min, m ³ /h, m ³ /d, l/s, l/min, l/h, hl/s, hl/min, hl/h, Ml/d, ft ³ /s, ft ³ /min, ft ³ /h, ft ³ /d, gal/s, gal/min, gal/h, gal/d, Mgal/d, ImpGal/s, ImpGal/min, ImpGal/h, ImpGal/d g/s, g/min, kg/s, kg/min, kg/h, kg/d, t/min, t/h, t/d, lb/s, lb/min, lb/h, lb/d, STon/min, STon/h, STon/d, LTon/d
3.1.2	Flow URV	Upper range value (URV) At the analog output the amount of the measured value in the range 0 up to URV is displayed linear to the current range 4 to 20mA, at the digital output 1 to the frequency range 0 to end frequency	Depending on the nominal width according to 2...3m/s	Depending on the nominal width (according to 0.25 to 12m/s)
3.1.3	Limits	Absolute values in flow units from menu 3.1.1		
3.1.3.1	Lo Alarm Limit	Lower alarm limit (the lower alarm limit must be smaller than the upper alarm limit)	10% of the URV (depending on the nominal width according to 0.2...0.3m/s)	Depending on the nominal width (according to -13m/s to +13m/s)
3.1.3.2	Hi Alarm Limit	Upper alarm limit (the upper alarm limit must be greater than the lower alarm limit)	90% of the URV (depending on the nominal width according to 1.8...2.7m/s)	Depending on the nominal width (according to -13m/s to +13m/s)
3.1.3.3	Hysteresis	Hysteresis for limit values in % of full scale value	1 %	0 to 20 %

- 1 Parameters apply only to devices with 20 mA/Hart communication and digital output 2 (7ME503x-0xxxx)
2 Parameters apply only to devices with 20 mA/Hart communication and digital input (7ME503x-2xxxx)
3 Parameters apply only to devices with PROFIBUS communication (7ME503x-1xxxx)

Menu code	Device function, Parameters	Description	Factory setting	Setting options
3.1.4	Density Engr. Unit Density	Density of the medium Engineering unit of the medium density Density value for calculation of mass flow	kg/m ³ +1000.00 kg/m ³	g/cm ³ , kg/m ³ , lb/gal, kg/l, g/l, lb/in ³ , lb/Impgal 200 to 5000 kg/m ³
3.1.5	Direction	Main flow direction related to direction arrow on measuring tube (= forwards, positive flow values) Output of suppression of reverse flow Affects all outputs, totalizers and display. Hysteresis of detection of flow direction in % of full scale value	+Direction	+Direction, -Direction
3.1.5.1	Flow Direction			
3.1.5.2	Meas.Direction		forw.+rev.	forward only, forw.+rev.
3.1.5.3	Hysteresis		0.2 %	0 to 20 %
3.1.6	Low flow cut	Threshold for low flow cut in % of full scale value ^{1, 2} or absolute value in flow unit ³	1 %	0 to 20 %
3.1.7	Noise filter	Time constant τ for measured value attenuation; after a jump in the measuring variable, the output measured value reaches about 99% of the new setpoint after $5 \cdot \tau$ Does not affect totalizers.	3.00 s	0.0 to 200.0 s
3.1.7.1	Filtr.Time Con.			
3.1.7.2	Line Synchron.	Synchronization of the measuring cycle for frequency of the power supply to suppress mains frequency noise	Auto mode	On, Off, Auto mode ⁶ resp. not available ⁷

¹ Parameters apply only to devices with 20 mA/Hart communication and digital output 2

² Parameters apply only to devices with 20 mA/Hart communication and digital input

³ Parameters apply only to devices with PROFIBUS communication

⁶ Only for InterMag 2 devices

⁷ Only for TransMag 2 devices

(7ME503x-0xxxx)

(7ME503x-2xxxx)

(7ME503x-1xxxx)

(7ME5033)

(7ME5034)

Menu code	Device function, Parameters	Description	Factory setting	Setting options
3.1.7.3	Noise filter (contd.) Noise Suppress Suppress Time Suppress Limit	Values outside a tolerance range are evaluated for the duration of the blanking time with high attenuation. Time of effect of increased attenuation (0 s = blanking off) Tolerance range = floating average \pm tolerance value	 0 s 0 %	 0 to 100 s 0 to 100 %
3.1.8	Slurry mode ⁷	This is used when signals are severely impaired, e.g. for media with a high solids content or air locks (only Transmag)	Off	On, Off
3.2	Total. Forw.	Totalizer forwards		
3.2.1	Set forward	Reset totalizer to zero and stop or start	Cancel ^{1,2} Totalize ³	Cancel ^{1,2} , Reset+Stop, Reset+Start ^{1,2} , Totalize ³
3.2.2	Engr. Unit	Engineering unit of volume or Engineering unit of mass When you select a unit of mass, entry of the actual medium density is mandatory (menu 3.1.4)	DN 2...12: l DN >12: m ³	l, hl, m ³ , MI, ft ³ , Gal, MGal, ImpGal, MImpGal kg, t, g, lb
3.2.3	Alarm Limit		+1000000 l	-10 ⁸ to +10 ⁸

¹ Parameters apply only to devices with 20 mA/Hart communication and digital output 2

² Parameters apply only to devices with 20 mA/Hart communication and digital input

³ Parameters apply only to devices with PROFIBUS communication

⁷ Only for Transmag 2 devices

(7ME503x-0xxxx)

(7ME503x-2xxxx)

(7ME503x-1xxxx)

(7ME5034)

Menu code	Device function, Parameters	Description	Factory setting	Setting options
3.3	Total. rev.	Totalizer reverse		
3.3.1	Set reverse	Reset totalizer to zero and stop or start	Cancel ^{1,2} Totalize ³	Cancel ^{1,2} , Reset+Stop, Reset+Start ^{1,2} , Totalize ³
3.3.2	Engr. Unit	Engineering unit of volume or Engineering unit of mass When you select a unit of mass, entry of the actual medium density is mandatory (menu 3.1.4)	DN 2...12: l DN >12: m ³	l, hl, m ³ , MI, ft ³ , Gal, MGal, ImpGal, MImpGal kg, t, g, lb
3.3.3	Alarm Limit		-1 000 000 l	-10 ⁸ to +10 ⁸
3.4	Total. net	Totalizer forw./rev.		
3.4.1	Set net	Reset totalizer to zero and stop or start	Cancel ^{1,2} Totalize ³	Cancel ^{1,2} , Reset+Stop, Reset+Start ^{1,2} , Totalize ³
3.4.2	Engr. Unit	Engineering unit of volume or Engineering unit of mass When you select a unit of mass, entry of the actual medium density is mandatory (menu 3.1.4).	DN 2...12: l DN >12: m ³	l, hl, m ³ , MI, ft ³ , Gal, MGal, ImpGal, MImpGal kg, t, g, lb
3.4.3	Lo Alarm Limit	Lower alarm limit (the lower alarm limit must be smaller than the upper limit.)	-1 000 000 l	-10 ⁸ to +10 ⁸
3.4.4	Hi Alarm Limit	Upper alarm limit (the upper alarm limit must be greater than the lower limit.)	+1 000 000 l	-10 ⁸ to +10 ⁸
3.4.5	Hysteresis	Hysteresis for limit values	0 l	0 to +10 ⁸ (Unit the same as the counter unit in the menu 3.4.2)

¹ Parameters apply only to devices with 20 mA/Hart communication and digital output 2

² Parameters apply only to devices with 20 mA/Hart communication and digital input

³ Parameters apply only to devices with PROFIBUS communication

(7ME503x-0xxxx)

(7ME503x-2xxxx)

(7ME503x-1xxxx)

Menu code	Device function, Parameters	Description	Factory setting	Setting options
4. Device Outputs				
4.1	Analog Out ^{1, 2}	Analog output 4 to 20mA with HART communication		
4.1.1	Current limit	Upper limit of analog current	22 mA	20...22.5mA
4.1.2	Error signal	Output current in case of failure. With the setting "Hold ..s" a current of 3.6 mA is only output in the case of a longer failure, shorter failures are bridged with output of the last valid current	3.6 mA	3.6mA, 22mA, 24mA, Hold continuous, Hold 5s, 20s, 40s, 60s, 120s, 240s
4.1.3	Current range	Selecting the current range at the analog output on which the measuring range (menu 3.1.2) is shown. For the setting 0 to 20 mA the failure signal (menu 4.1.2) must be set to 22 or 24 mA.	4 ... 20 mA	4 ... 20 mA; 0 ... 20 mA;
4.1.4	Split mode	The split mode divides the measuring range into two domains: <ul style="list-style-type: none"> • Domain 1 from 0 to 'Split value' • Domain 2 from 'Split value' to 'URV' (upper range value, menu 3.1.2) At digital outputs 1 or 2, it is possible to indicate whether the current measured value is within domain 1. To do this, the function 'Split value active' must be set (menu 4.2.1 and 4.3.1)	Inactive	Inactive, active
	Split value	End value of domain 1 (only when 'Split mode = active')	URV (menu 3.1.2)	Depends on the nominal width (corresponding to 0.25 to 12 m/s, <URV)

¹ Parameters apply only to devices with 20 mA/Hart communication and digital output 2 (7ME503x-0xxxx)
² Parameters apply only to devices with 20 mA/Hart communication and digital input (7ME503x-2xxxx)

Menu code	Device function, Parameters	Description	Factory setting	Setting options
4.1	PROFIBUS ³	PROFIBUS communication		
4.1.1	Bus Address	PROFIBUS address	126	1 to 126
4.1.2	Ident-Nr.	Selection of appropriate device database file (GSD)	Manufact.spec.	Profile spec., Manufact.spec.
4.2	Digit.Output1	Frequency or pulse signal for flow or alarm signal		
4.2.1	Function	Assignment of a function to digital output 1 'Split value active': the active output indicates a current flow value in the 0 to 'Split value' range (not effective for PROFIBUS).	Pulse	Pulse, Frequency, Alarm, Flow direction forw. Flow min, Flow max, Flow min/max, Total. forw. max, Total. rev. min, Total. net max, Total. net min Split value active, No function
4.2.2	Signal Type	Definition of signal logic for active event	Passive-pos.	Active-pos., ^{1, 2} Active-neg., ^{1, 2} Passive-pos., Passive-neg.
4.2.3	Pulse Rate Engr. Unit Pulse Rate	Number of pulses per unit of quantity (only effective with "Pulse" function) Engineering unit of quantity to which the number of pulses refers Number of pulses per unit of quantity	DN1..12: Imp/l >DN12: Imp/m ³ Depending on the nominal width 10Imp/l... 1Imp/m ³	pulses/l, m ³ , MI, ft ³ , Gal, MGal, ImpGal, Mimp•Gal, kg, t, lb, 0.01 to 9999 pulses/unit
4.2.4	Pulse Width	(only with "Pulse" function)	+0.1 ms	0.1 to 2000 ms
4.2.5	Fullsc. Freq	Frequency output at full scale flow value at digital output 1 (only effective for "Frequency" function)	10000 Hz	2 to 10000 Hz

¹ Parameters apply only to devices with 20 mA/Hart communication and digital output 2

² Parameters apply only to devices with 20 mA/Hart communication and digital input

³ Parameters apply only to devices with PROFIBUS communication

(7ME503x-0xxxx)

(7ME503x-2xxxx)

(7ME503x-1xxxx)

Menu code	Device function, Parameters	Description	Factory setting	Setting options
4.3	Digit.Output2 ¹			
4.3.1	Function	Assignment of a function to digital output 2 'Split value active': the active output indicates a current flow value in the 0 to 'Split value' range (not effective for PROFIBUS).	Alarm	Alarm, Flow dir. forw., Flow min, Flow max, Flow min/max, Total. forw. max, Total. rev. max, Total. net max, Total. net min, Split value active, No function
4.3.2	Signal type	Definition of signal logic for active event	Contact closes	Contact closes, Contact opens
4.3	Digit.input ²			
4.3.1	Function	Assignment of a function to the input: Measured value=0: Measured value is set to 0 (affects all outputs and totalizers) Totalizer reset: reset+start	Measured value = 0	Meas. val. = 0, Total. forw. reset, Total. rev. reset, Total. net reset, Total. all reset, No function
4.3.2	Signal Type	Definition of signal logic	High-active	High-active, Low-active

¹ Parameters apply only to devices with 20 mA/Hart communication and digital output 2

² Parameters apply only to devices with 20 mA/Hart communication and digital input

³ Parameters apply only to devices with PROFIBUS communication

(7ME503x-0xxxx)

(7ME503x-2xxxx)

(7ME503x-1xxxx)

Menu code	Device function, Parameters	Description	Factory setting	Setting options
5. Identification				
5.1	Funct. Unit			
5.1.1	Tag	Tag number	(customer-specific)	text max. 32 characters ³ / 8 characters ^{1,2}
5.1.2	Descriptor	Tag descriptor	(customer-specific)	text max. 32 characters ³ / 16 characters ^{1,2}
5.1.3	Message	Tag message	(customer-specific)	text max. 32 characters
5.2	Manuf. Ident.			
5.2.1	Product type	Transmitter order number	(7ME5033-xxxx x-xxA0)	
5.2.2	Serial number	Transmitter serial number	(N1xxxx-82xxxxx)	
5.2.3	Software Rev.	Software version in the transmitter	(2.x.x)	
5.2.4	Device ID	Clear device identification; corresponds to HART long address	(device-specific HART long address)	(1 to 99 999; can only be set with factory code by HART)
5.2.5	Manuf. Date	Transmitter manufacture date; form: DDMMYY	(device-specific manufacture date)	(DDMMYY; can only be set with factory code by HART)
5.2.6	Sensor	Input only possible if no data can be read from SmartPLUG		
5.2.6.1	Nom. Diameter ⁵ Diameter	Inside nominal diameter of the sensor with probes: interior diameter of the surrounding tube	(nominal width) 0.1 m	DN2...2000 / 0.5...80in, probe (Only after 'Probe' is selected:) 0,1 ... 5 m
5.2.6.2	Product Type ⁴	Sensor order number	(7ME5033 -xxxxx-xxA0)	from SmartPLUG
5.2.6.2	Analog Transmag ⁵	Select 'Yes' for measuring sensors with an R100 constant In this case, a CFH value must be entered in the 6.7.2 menu according to the following formula: CFH = 176,715 * DN ² /R100, DN = nominal diameter in mm)	No	No, Yes
5.2.6.3	Serial Number ⁴	Serial number of sensor	(serial number)	from SmartPLUG

¹ Parameters apply only to devices with 20 mA/Hart communication and digital output 2 (7ME503x-0xxxx)
² Parameters apply only to devices with 20 mA/Hart communication and digital input (7ME503x-2xxxx)
³ Parameters apply only to devices with PROFIBUS communication (7ME503x-1xxxx)
⁴ only with sensors with SmartPLUG connected
⁵ Entry only possible for measuring sensors **without** SmartPLUG

Menu code	Device function, Parameters	Description	Factory setting	Setting options
6. Service				
6.1	Enter Code	Input of code number agreed under "Customer Code" (menu 6.2) for releasing local parameterization	0	0 to 9999 (according to setting under menu 6.2)
6.2	Customer Code	Selection of personal code Code 0: Parameters are not protected by a code. Code >0: Parameters can only be changed after entering the code under "Enter Code" (menu 6.1)	0	0 to 9999
6.3	Service Code	Input of factory code for extended service functions	0	0 to 99999
6.4	Reset	Device reset (without parameter changes)	Cancel	Cancel, Reset
6.5	Control Values			
6.5.1	Volt. U_m Volt. U_{ref} ⁷	Control value for magnetic field current Control value for reference voltage		
6.5.2	Volt. U_{sig}	Electrode differential voltage		
6.5.3	Volt. U_{el1}	Control value for voltage between electrode 1 and medium		
6.5.4	Volt. U_{el2}	Control value for voltage between electrode 2 and medium		
6.5.5	Flow % Range ^{1,2}	Actual flow in % of set full scale value		
6.5.6	Sampl. Frequ.	Actual measuring frequency	(approx. 2 x magnetic frequency)	

¹ Parameters apply only to devices with 20 mA/Hart communication and digital output 2

² Parameters apply only to devices with 20 mA/Hart communication and digital input

⁶ Only for InterMag 2 devices

⁷ Only for TransMag 2 devices

(7ME503x-0xxxx)

(7ME503x-2xxxx)

(7ME5033)

(7ME5034)

Menu code	Device function, Parameters	Description	Factory setting	Setting options
6.5.7	Selftest 0 % FS	Display of internal control values of measuring electronics. Run self-test to update (menu 2.4.1) Zero Gain	(result display of the last self-test) (xxxxxxx) (current status active or inactive)	triggered when selecting menu 2.4.1
6.5.8	Service Info	Coded service information	(Info)	
6.5.9	Digital Input ²	Status of the digital input under consideration of the set signal type	(actual status active or inactive)	
6.6	Zero Trim			
6.6.1	Zero Flow Cor.	Correction value for the zero point of the flow measurement in m/s	0	-1 to +1 m/s
6.6.2	Start Correct.	Start of zero calibration; The medium must be at a standstill during calibration!	Cancel	Cancel, Start
6.7	Trim Parameter	Values in 6.7.2.4 can only be written if no SmartPlug data can be read		
6.7.1	Cal.factor	User-specific calibration factor; the measured flow value is multiplied by this factor before output (affects all outputs, totalizers and display)	1.0	0.5 to 1.5
6.7.2	CFH ⁵ CFR ^{5, 7}	Calibration value for hydraulic reference point at 1m/s Calibration value for reference path	400 100	
6.7.3	ZPH ⁵	Calibration value for hydraulic zero point	0	

¹ Parameters apply only to devices with 20 mA/Hart communication and digital output 2

² Parameters apply only to devices with 20 mA/Hart communication and digital input

⁵ Entry only possible for measuring sensors **without** SmartPLUG

⁷ Only for Transmag 2 devices

(7ME503x-0xxxx)

(7ME503x-2xxxx)

(7ME5034)

Menu code	Device function, Parameters	Description	Factory setting	Setting options
6.7.4	Excitat.Freq. ⁵	Magnetic field current frequency ⁶ , depending on sensor and power supply Magnetic current curve ⁷ : Bipolar PP f/5: Standard applications Bipolar f/3: rapid applications Unipolar f/6: Measuring sensors ≤DN 150 up to year of construction 1995	6 Hz or f/8 Bipolar PP	3 Hz or f/16, 6 Hz or f/8, 12 Hz or f/4 Bipolar PP f/5 Bipolar f/3, Unipolar f/6
6.7.5	EmptyTube Det. Act.Value EI1 Act.Value EI2 Threshold	Adjustment of electrode immersion check Display of actual control value of electrode EI1 in % of end value Display of actual control value of electrode EI12 in % of end value Threshold of diagnostic function "Immersion check" for "Tube empty" message (see table 5-2 and menu 2.3)	 33 %	 5 to 95 %

² Parameters apply only to devices with 20 mA/Hart communication and digital input (7ME5033-2xxxx)
⁵ Parameters apply only to devices with sensors without SmartPLUG
⁶ Only for InterMag 2 devices (7ME5033)
⁷ Only for TransMag 2 devices (7ME5034)

Table 5-1 Functions of the SITRANS FM InterMag 2 transmitter

5.3 Device Functions and Parameters



Notes !

- The desired operating language can be set in the control and display unit in menu item "1.1.1 Language".
- The background illumination of the LCD is switched on automatically the first time an operating element is actuated. The illumination goes out about 10 minutes after last actuating an operating element. If the display is constantly lit, you can set this using the menu item "1.1.5 Illumination".

5.3.1 Function Group Display

The main display (multi display) appears after restarting the transmitter.

Display parameters menu item 1.1 Within the menu you have the following display or setting options:

- Language, menu item 1.1.1
- Line 1, menu item 1.1.2 (definition of measured value)
- Line 2, menu item 1.1.3 (definition of measured value)
- Display of flow value, menu item 1.1.4 (only for line 2)
- Illumination, menu item 1.1.5 (display test)

Multi display menu item 1.2 simultaneous display of two measuring variables

Flow menu item 1.3 display of current flow

Totalizer menu item 1.4 display of current flow
This menu displays all totalizers which can all be reset together.
These are:

- Totalizer forwards, menu item 1.4.1
- Totalizer reverse, menu item 1.4.2
- Totalizer net, menu item 1.4.3
- Set (all), menu item 1.4.4



Note!

These totalizers show the total flow volume since starting the measurement. Use the menu items 3.2, 3.3 and 3.4 for separate setting and resetting of the units. The totalizer is restarted when it overruns.



Note!

The value range of the totalizers in PROFBUS and HART communication is principally -10 38 to + 10 38 m 3 . However, since the value range of the local display is limited to .999 999 999, the display stays at 999 999 999 when this range is exceeded, totalizing continues internally however.

Flow velocity
menu item 1.5

display of current measured value in m/s

Frequency
menu item 1.6

display of current measured value in Hz

Analog Out^{1,2}
menu item 1.7

display of current measured value in mA

¹ Parameters apply only to devices with 20 mA/Hart communication and digital output 2 (7ME503x-0xxxx)
² Parameters apply only to devices with 20 mA/Hart communication and digital input (7ME503x-2xxxx)

5.3.2 Function Group Diagnostics

Device status
menu item 2.1



During normal operation, test routines are run continuously. The display "OK" appears in the case of error-free operation after selecting the menu item 2.1 (device status). An error message is displayed in clear text in the event of an error. The possible error messages are listed in Table 5-2 and the assignment of the error messages to the individual outputs specified. The error message can only be output via the digital outputs 1 and 2 and the analog output if configured accordingly (selection of `Alarm' function for the digital outputs or `Failure signal' for the analog output) (see menu items 4.1.2, 4.2.1 and 4.3.1).

A flashing "F" appears for process related errors or a flashing "D" for device errors in the first line at the top right of the display when errors occur. Should errors in groups 'F' and 'D' occur at the same time, only 'D' will flash.

In communication via PROFIBUS the diagnostic message displayed here is also reported under the extended diagnosis with the diagnostic bit "EXTENSION_AVAILABLE" (see section 5.4.3).

Error message	Flashing indication in display menu	Error is signaled at the analog output	Error is signaled at digital output 1 and 2	PROFI-BUS
Measurement module failure	F	-	-	x
Calibration failure measurement module	F	-	-	x
Simulation is running	F	-	-	x
Flow measurement uncertain	F	-	-	x
Calibration is running	F	x	x	x
Tube empty	F	x	x	x
Measuring range overflow > 110 %	F	x	x	x
COM Module failure	D	-	-	-
Memory failure	D	x	x	x
Software failure	D	x	x	x
Sensor failure	D	x	x	x
Flow measurement disturbed	D	x	x	x

Table 5-2 Error messages

For texts with more than 16 characters, the marks ◀ and ▶ in the first and last segment of the device display respectively indicate that there are other characters to the left and/or right of the displayed text. You can display these by actuating the  and  operating elements.

Electrode check

Menu item 2.2

The electrode DC voltage is scanned cyclically after selecting this menu item and is checked for plausibility. This detects deposits on the electrodes for example. If there is a fault or an error, the alarm signal 'Flow measurement unreliable' is triggered.

**Note!**

This function assumes a sensor with SmartPLUG!

Empty Tube Det.

menu item 2.3

The function checks whether the electrodes of the sensor are wetted by the medium. To do this, you have to determine the interval between two monitorings.

If the electrodes have no contact with the medium, an alarm signal (tube empty) is triggered through the digital outputs. This alarm is also triggered in the case of an insulating coating on the electrodes.

**Warning!**

This message does not mean that the tube has actually run empty. Therefore you must make sure that the pipeline is actually empty before you remove the tube or the electrodes!

**Note!**

This function is conditional upon a minimum conductivity of the medium of 50 μ S/cm!

Response threshold and timing behavior of the "immersion check" function depend on the conductivity of the medium and the nominal width and cladding of the sensor. The switching threshold can be adapted to these conditions if necessary (see menu item 6.7.5).

Device test
menu item 2.4

The device test comprises the following test components:

- **Self test**, menu item 2.4.1
The self test routines are inserted in the current measurements and are completed after about 60 seconds. If there is no error, "OK" is displayed, otherwise "not OK". The type of error can then be read out in the menu item "2.1 Device status".
- **Display test**, menu item 2.4.2
The LCD is checked with this menu item. The display is initially dark for approx. 5 seconds and then bright for approx. 5 seconds.

Simulation flow
menu item 2.5.1

The flow can be simulated in a range from $\pm 110\%$. Here you also have the possibility of checking displays, totalizers, limit values and outputs in certain measuring ranges. The running simulation is indicated by a flashing 'F'. It ends at the end of a previously set period or after entering the 'End' parameter in this menu item.

Simulation outputs
menu item 2.5.2
2.5.3
2.5.4

With this function you can check the signal circuits of the analog output, the digital outputs 1 and 2 as well as the flow. In the individual menu items, you select the value to be simulated with the and operating elements. You activate the setting by confirming the selected value with the operating element. The running simulation is indicated by a flashing 'F'. You end simulation of the output signal by actuating the operating element (exit the menu item). Digital output 1 must be configured for the "Alarm" function for simulation of the alarm signal (setting in the menu item "4.2.1 Function").

5.3.3 Function Group Measuring Functions

Flow
menu item 3.1

You have the following setting options in this menu:

- **Engineering unit**, menu item 3.1.1
This function offers you the possibility of choosing between units of volume flow (volume unit per time) or mass flow (mass unit per time). If a unit of mass is selected, it is mandatory to enter the density of the medium in menu item 3.1.4.

- **Flow Upper Range Value (URV)**, menu item 3.1.2
The full scale value is set depending on the nominal width of the sensor and the valid speed range (0.25 - 12 m/s). The start of scale value is always 0 (zero).

Special features of PROFIBUS devices:

Although the profile parameter for the start of scale value (0%) can always be written by acyclic communication, values not equal to 0 are rejected.

The output scale does not appear in the local operating unit. It is always set identical to the measuring scale automatically, i.e. the profile parameters start or end of the output scale are set automatically to 0 or "URV". Other values are rejected in acyclic PROFIBUS communication.

The set URV only has an influence on the percentage defined values such as "flow in %", hysteresis and the digital output 1. Measured values outside this range are also reported by PROFIBUS as valid measured values providing they are within the sensor limits. The sensor limits for flow depend on the nominal width and correspond to a flow velocity range of about -13m/s to +13m/s.

Measured values outside the sensor limits are displayed but are no longer within the specified range; "uncertain, nonspecific, low limited" or "uncertain, nonspecific, high limited" is then reported as a measured value status.

- **Limits**, menu item 3.1.3, consisting of:
Low Alarm Limit, menu item 3.1.3.1 and
High Alarm Limit, menu item 3.1.3.2
The input is made in absolute values within the sensor limits (depending on the nominal width, corresponding to -13 m/s to + 13 m/s). Alarm limits of min. 10% and max. 90% of the URV are set at the factory.
Exceeding or dropping below these limit values are signaled at digital output 1 or 2 if the function of these outputs is configured appropriately (menu items 4.2.1 and 4.3.1). In PROFIBUS communication, these events are reported by the limit bits in the measured value status.

Special features of PROFIBUS devices:

In addition, the profile parameters for the "Low Warning Limit" and "High Warning Limit". Can be set independently of the alarm limits by acyclic PROFIBUS communication. They do not appear in the local operating unit. Exceeding of the warning limits is only signaled by PROFIBUS communication.

- **Hysteresis**, menu item 3.1.3.3
The limit values (menu items 3.1.3.1 and 3.1.3.2) can have a hysteresis added to prevent "fluttering" of the switching output (see Figure 5-7).
- **Density**, menu item 3.1.4
You must specify unit and density here. The volume flow q_v is converted to mass flow q_m automatically using the formula ($q_m = q_v \cdot \rho$).

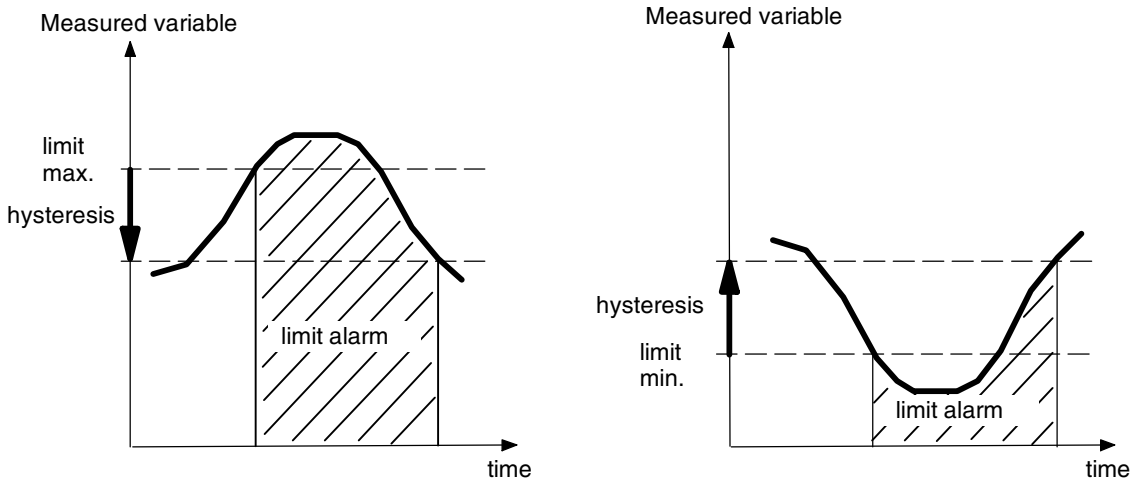

Figure 5-7 Limit value message and hysteresis

- **Direction**, menu item 3.1.5. This item is divided into:
 - **Flow direction**, menu item 3.1.5.1
The flow direction is preset at the factory and indicated by the arrow on the sensor. If the flow direction does not match the direction of the arrow it must be adapted in this menu item.

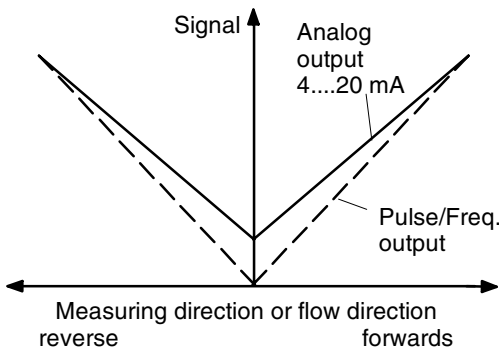

Figure 5-8 Setting **forw.+rev.**

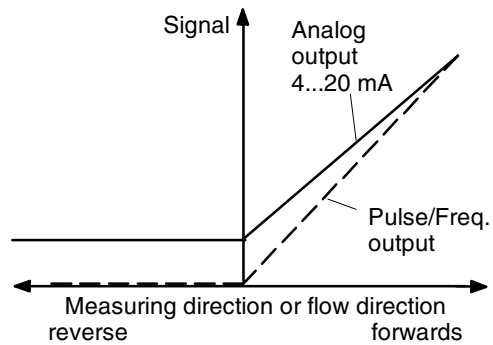
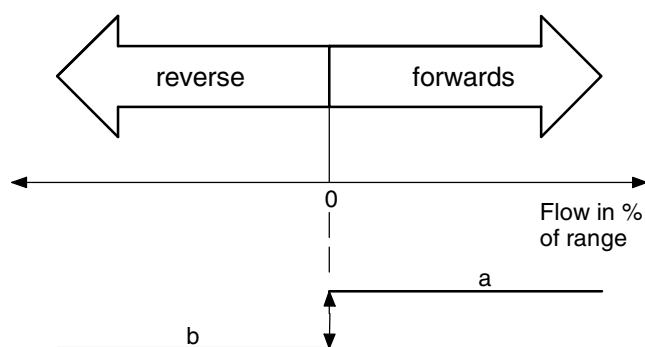

Figure 5-9

Setting **forwards**

- **Measuring direction**, menu item 3.1.5.2
The measuring system is able to detect the flow in forward and backward direction and to pass on the appropriate signal proportionally to the analog or digital output. In "forwards" parameterization, only signals in this direction are output or accumulated internally.

Example 1: Hysteresis = 0 %



Example 2: Hysteresis = 1 %

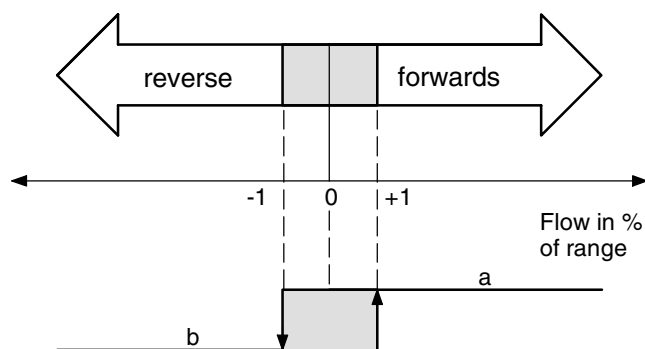

Switching status' of the relay for selected signal type:

- Contact closes: a → Relay contact closed
b → Relay contact open
- Contact opens: a → Relay contact open
b → Relay contact closed

Figure 5-10 Hysteresis flow direction

- **Hysteresis**, menu item 3.1.5.3
The limit values (menu items 3.1.5.1 and 3.1.5.2) can have a hysteresis added to prevent "fluttering" of the switching output (see Figure 5-10).
This setting is made in % of the set full scale value in the menu item 3.1.5.3 "Hysteresis". If, for example, the hysteresis is 1 %, the relay contact does not switch until a flow of -1% of the full scale value and returns to the original position at a flow of +1% of the full scale value.

- **Low flow cut**, menu item 3.1.6
This parameter determines the switching point for low flow cut. The low flow cut prevents flow being measured in the lower range (e.g. fluctuating liquid columns at a standstill). The low flow cut affects: display, totalizers, analog output and pulse frequency output as well as HART and PROFIBUS communication.

In devices with HART communication, the value of the low flow is related percentage-wise to the upper range value (menu item 3.1.2). In devices with PROFIBUS communication, the absolute value must be entered in the selected unit of flow (menu item 3.1.1).

- **Filter time constant**, menu item 3.1.7.1
The jump response can be suppressed in this menu item. This may be necessary depending on the application, for example in the case of fast changing flows to keep the display value or analog value calm.
- **Line synchronization**, menu item 3.1.7.2
Selection only possible for Intermag 2; for Transmag 2, the mains frequency is generally synchronized. In the case of a DC power supply to the transmitter (Intermag 2 only), this parameter may not be set to "on".
- **Noise Suppress**, menu item 3.1.7.3
This function serves to eliminate temporary, application-related interference within a fixed time window.

Every measured value within a measuring pulse is compared with the previously determined value. If it is outside the tolerance band set under menu item 3.1.7.3 (the specified % value refers to the set full scale value), the device operates with a filter time constant of 10 s.

This applies for the suppress time set in menu item 3.1.7.3. If a greater deviation occurs during this time, the time starts again from the beginning. If a disturbed signal is applied continuously, the device remains set to the greater filter time constant until the unattenuated measured values are back within the selected tolerance band. The device switches back over to normal mode at the end of time "t" after the last detected deviation.

- **Slurry mode**, menu item 3.1.8
For media with a high solids content, magnetically conductive solids or air locks, the stability of the measured values can be significantly improved with this setting, while the reaction speed remains the same when the flow is altered.
If necessary, the stability of the measured value can be further increased using the "Filter time constant" (menu item 3.1.7.1) or "Error blanking" (menu item 3.1.7.3) functions, although this will in turn reduce the measuring dynamics.

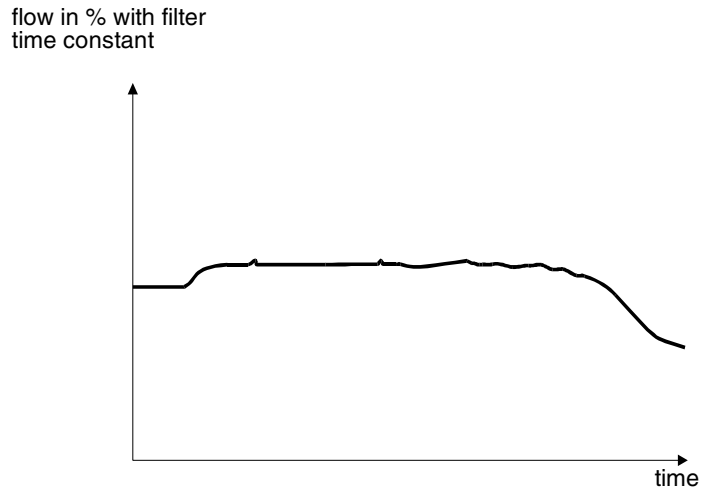
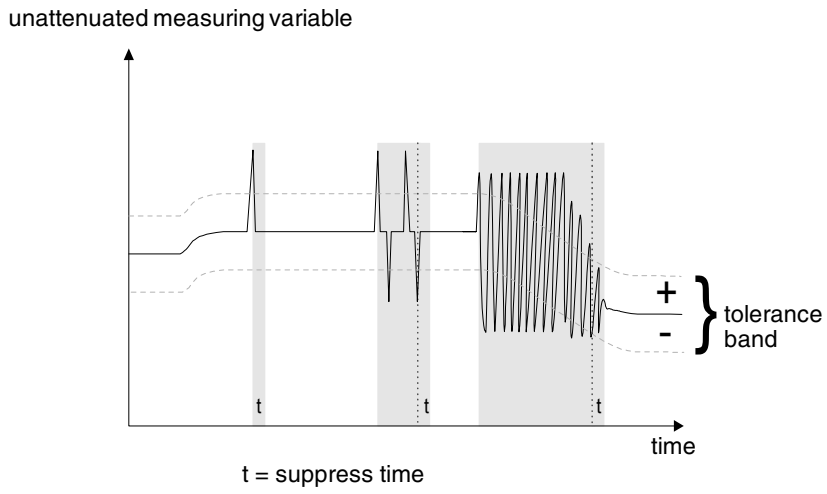

Figure 5-11 Example for the effect of a noise signal filter

Total. forwards
menu item 3.2

You have the following setting options in this menu:

- **Set**, menu item 3.2.1
In this menu you can reset the forwards totalizer to zero and restart if necessary.
If the totalizer overruns the optical display of the totalizer stops at "•999999999" but the device continues counting internally. You have to set a greater unit to be able to read the current totalizer reading again.
You have the following individual setting options:
 - Reset+Stop: the totalizer is set to 0 and held.
 - Reset+Start: the totalizer is set to 0 and restarted ^{1,2}
 - Totalize: the totalizer is started ³
- **Unit**, menu item 3.2.2
With this function you can select physical units or switch from one unit to another. In the latter case the device converts the previous totalizer reading into the new unit.
- **Alarm limit**, menu item 3.2.3
Here you can set all values from 0 to +10⁸. You can assign reaching or exceeding this limit value as a signal to a digital output.

Total. reverse
menu item 3.3

You have the following setting options in this menu:

- **Set**, menu item 3.3.1
In this menu you can reset the reverse totalizer to zero and restart if necessary.
If the totalizer overruns the optical display of the totalizer stops at "•999999999" but the device continues counting internally. You have to set a greater unit to be able to read the current totalizer reading again.
You have the following individual setting options:
 - Reset+Stop: the totalizer is set to 0 and held.
 - Reset+Start: the totalizer is set to 0 and restarted ^{1,2}
 - Totalize: the totalizer is started ³
- **Unit**, menu item 3.3.2
With this function you can select physical units or switch from one unit to another. In the latter case the device converts the previous totalizer reading into the new unit.
- **Alarm limit**, menu item 3.3.3
Here you can set all values from 0 to -10⁸. You can assign reaching or exceeding this limit value as a signal to a digital output.

1	Parameters apply only to devices with 20 mA/Hart communication and digital output 2	(7ME503x-0xxxx)
2	Parameters apply only to devices with 20 mA/Hart communication and digital input	(7ME503x-2xxxx)
3	Parameters apply only to devices with PROFIBUS communication	(7ME503x-1xxxx)

Totalizer net menu item 3.4

You have the following setting options in this menu:

- **Set**, menu item 3.4.1
In this menu you can reset the totalizer net to zero and restart if necessary.
The net totalizer forms the difference (error sum) between forward and backward flow.
If the totalizer overruns the optical display of the totalizer stops at "•999999999" but the device continues counting internally. You have to set a greater unit to be able to read the current totalizer reading again.
You have the following individual setting options:
 - Reset+Stop: the totalizer is set to 0 and held.
 - Reset+Start: the totalizer is set to 0 and restarted ^{1,2}
 - n Totalize: the totalizer is started ³
- **Unit**, menu item 3.4.2
With this function you can select physical units or switch from one unit to another. In the latter case the device converts the previous totalizer reading into the new unit.
- **Low Alarm Limit value**, menu item 3.4.3
Here you can set all values from -1 to -10^9 . You can assign reaching or exceeding this limit value as a signal to a digital output.
- **High Alarm Limit**, menu item 3.4.4
Here you can set all values from 1 to $+10^9$. You can assign reaching or exceeding this limit value as a signal to a digital output.
- **Hysteresis**, menu item 3.4.5
The limit values (menu items 3.4.3 and 3.4.4) can have a hysteresis added to prevent "fluttering" of the switching output.

¹ Parameters apply only to devices with 20 mA/Hart communication and digital output 2 (7ME503x-0xxxx)
² Parameters apply only to devices with 20 mA/Hart communication and digital input (7ME503x-2xxxx)
³ Parameters apply only to devices with PROFIBUS communication (7ME503x-1xxxx)

5.3.4 Function Group Device Outputs

Analog out
menu item 4.1

This menu only appears only in devices with a 20 mA output (7ME503x-0xxxx und -2xxxx).

The following settings are possible:

- **Current limiting**, menu item 4.1.1
The upper current limit for the output signal is determined in this menu item.

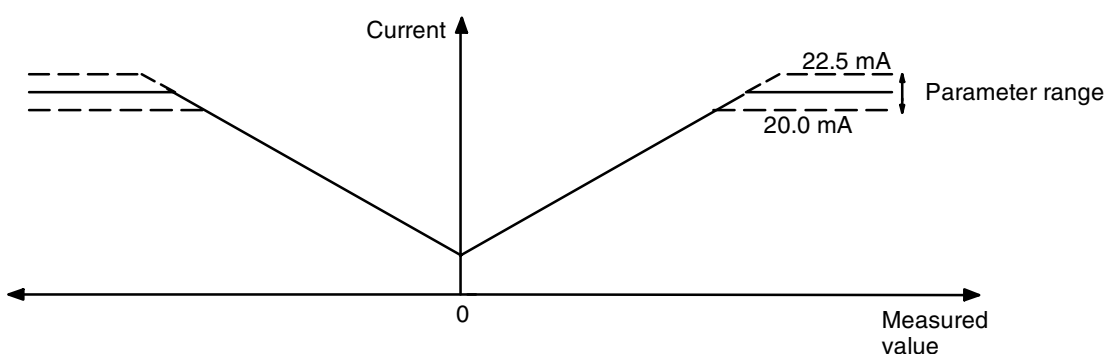

Figure 5-12 Current limiting

- **Failure signal**, menu item 4.1.2
In the event of a fault, e.g. a device error or measuring error due to entrapment of air, the analog output outputs a pre-defined current. The following settings are possible:
 - 3.6 mA
 - 22 mA
 - 24 mA
 - Hold for a defined time (5...240 seconds), then 3.6 mA
 - Hold permanently

With the "Hold 5 s" setting you can bypass temporary faults (e.g. air entrapment in the medium) for up to about 5 s without the analog signal outputting an error message. The same applies accordingly for "Hold 20 s", "Hold 40 s" etc. The last valid measured value is output during the fault. If the fault lasts less than 5 s the current measured value is output at the end of the fault. If the fault persists (e.g. longer than 5 s) the output signal is set to 3.6 mA.

In the "Hold permanently" setting the last valid value is output until the fault is eliminated.

In the current range between 0 and 20 mA, the 3.6 mA failure signal or "Stop" is not recommended; in this case, the setting '22 mA' or '24 mA' must be selected.

- **Split mode** (combined counter), menu item 4.1.4
The Split mode is activated when 'Active' is selected.
The "Split value" divides the measuring range (URV) set in menu item 3.1.2. The split value is only effective when it is smaller than the full-scale value (upper range value, URV).
When Split mode is activated, if there is a current flow value in the lower subdomain (0 to split value), this subdomain is shown in a linear way on the set current range 0-20 mA or 4-20 mA, i.e. a current of 20 mA corresponds to the split value. This status can be indicated on digital outputs 1 or 2, if the "Split value active" function has been set there (menu 4.2.1 and 4.3.1)
If the current flow value is within the upper subdomain (split value to full-scale value), the range 0 to URV is shown in a linear way on the set current range as for the inactive Split mode.

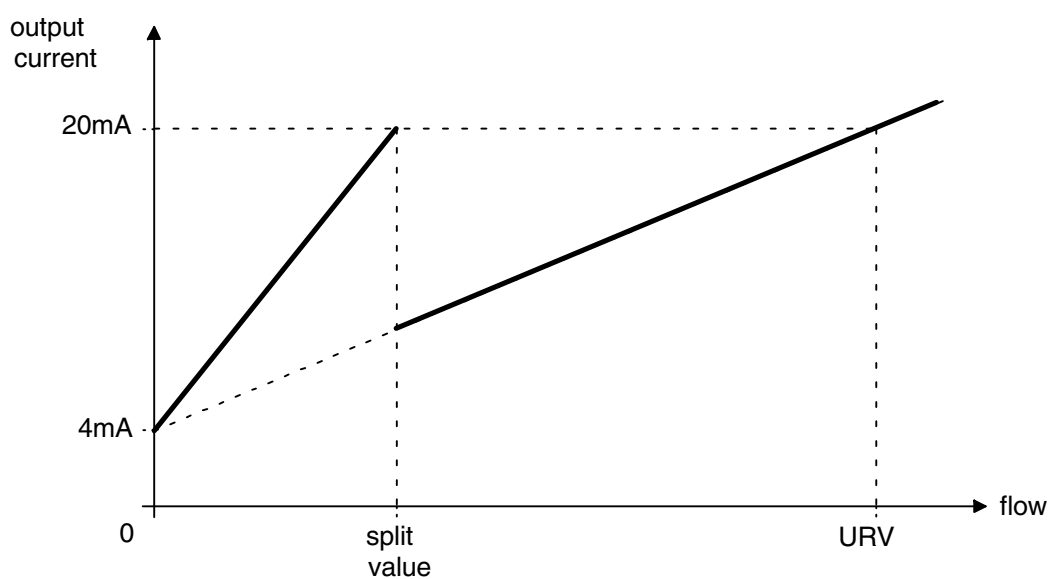

Figure 5-13 Split mode in domain 4 ... 20 mA

PROFIBUS
Menu item 4.1

This menu only appears in PROFIBUS devices.
(7ME 503x-1xxxx).

This menu gives you the following setting options:

- **Bus address**, menu item 4.1.1
The address 126 (factory setting) is reserved for newly connected devices and must be changed to a smaller value at the latest after commissioning on the bus. A value between 30 and 125 is recommended because addresses below 30 are only assigned for bus masters as a rule.
An address < 126 is only addressable when no cyclic communication is taking place and all acyclic connections are closed.
With the PROFIBUS variable "factory_reset = 2712" the address can be reset to the factory setting 126.

Every address may only be assigned for one device on the connected bus!

- **Ident No.**, menu item 4.1.2
The device profile for the cyclic data traffic can be selected here. You have the following options:

- profile-specific (=Ident No. 0x9740) means:
restricted functions; i.e. only cyclic parameters according to profile 3.0 (flow and totalizer net).
- manufacturer-specific (= Ident No. 0x80C4) means:
full functions, i.e. cyclic parameters according to profile 3.0 and additional manufacturer-specific parameters (e.g. totalizer forwards, totalizer reverse).

The connected PROFIBUS master must be configured with a device database file (GSD) according to the set ID No.
See also section 7.3.2 (Device database file)

Digital output 1
menu item 4.2

You have the following setting options in this menu:

- **Function**, menu item 4.2.1
You can configure digital output 1 as a pulse, frequency, alarm or status output (see menu Table 5-1)

When "Split value active" is selected, the output is active when the current level of the flow value is within the lower subdomain 0 to "Split value"; the output current is then scaled to the 0 to "Split value" range. If the flow value exceeds this subdomain, the output current is scaled to the 0 to URV range (See Figure 5-13).

- **Signal type**, menu item 4.2.2
You can configure different signal types for the output signal of digital output 1:

- Active:
The device-internal voltage is used (+24 V).
- Passive:
External supply required.

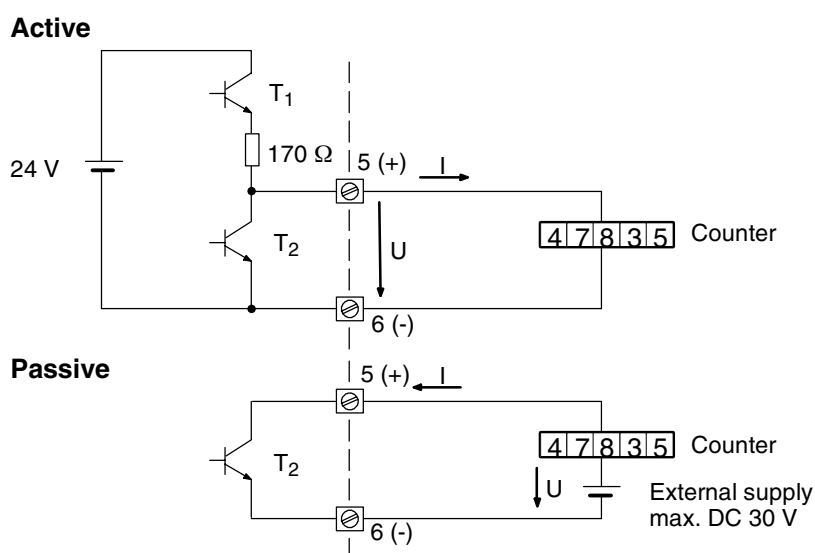

Figure 5-14 Active and passive signals

You can generate signals with positive and negative logic (positive and negative pulses). Figure 5-15 illustrates the setting options.

- **Pulse rate**, menu item 4.2.3
The pulse valency indicates how many pulses per unit of volume or mass are output.
When the "Pulse" function is selected, you have to set the number of pulses per unit of volume or mass.

- **Pulse width**, menu item 4.2.4
You can determine the pulse/pause ratio of the pulse output with the pulse width. The pulse width can be set in a range from 0.1 to 2000 ms. A maximum pulse width is calculated in relation to the set full scale value and the set pulse valency. The maximum pulse frequency is 5 kHz.

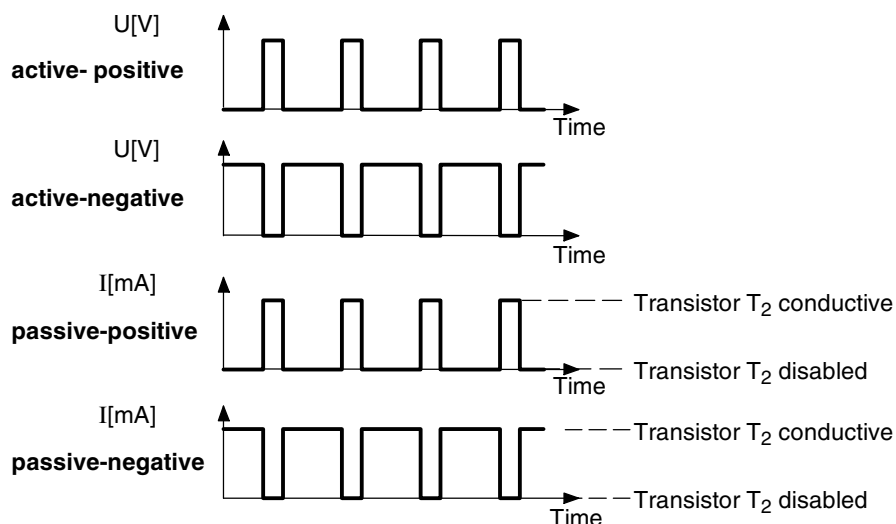

Figure 5-15 Signal types for digital output 1

- **Full scale frequency**, menu item 4.2.5
The frequency is permanently assigned to the flow. The pulse/pause ratio is constant 1:1. If the "Full scale frequency" function is selected, the frequency is set in the range from 2 ... 10000 Hz.

Digital output 2
menu item 4.3

The digital output 2 is available in device variants with the MLFB-No. 7ME503x-0xxxx-xxxx (Hart communication and digital output). You have the following setting options in this menu:

- **Function**, menu item 4.3.1
You can configure the digital output 2 (relay contact) as an alarm or status output (see the menu in Table 5-1).

- When "Split value active" is selected, the output is active when the current level of the flow value is within the lower subdomain 0 to "Split value"; the output current is then scaled to the 0 to "Split value" range. If the flow value exceeds this subdomain, the output current is scaled to the 0 to URV range (See Figure 5-13).



Note!

The relay contact is open in the "no function" setting.

- Signal type, menu item 4.3.2
You can set the function of the relay as follows in this menu item:
 - Contact closes: the relay contact closes in the event of an
 - alarm
 - Flow in forward direction
 - Limit value message
 - Contact opens: the relay contact opens in the event of an
 - alarm
 - Flow in forward direction
 - Limit value message

The Table 5-3 explains the switching status' of the relay.

Setting	No alarm Backward flow No limit value message	Alarm message Forward flow Limit value message
Contact closes		
Contact opens		

Table 5-3 Switching status' of the relay

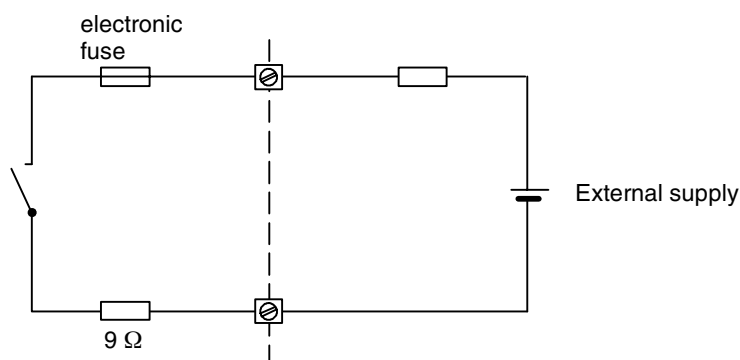

Figure 5-16 Digital output 2

At high inductive loads, the digital output must be protected against transient overvoltage with a suitable external recovery diode.

The electronic fuse is tripped in the event of overloading. The recovery time of the fuse is a few minutes. The relay contact is open in the no-load state.

Digital input
Menu item 4.3

The digital input is available with the device variant 7ME5033-2xxxx (Hart communication and digital input). You have the following setting options in this menu:

- **Function**, menu item 4.3.1
By applying an external power supply, you can create a switching input, for example using a switch (see also Figure 5-17). You have the following possibilities depending on the configuration:
 - Set the measured value to "0" (all outputs and displays are reset to zero and the totalizers are stopped)
 - Reset the forwards totalizer
 - Reset the reverse totalizer
 - Reset the net totalizer
 - Reset all totalizers

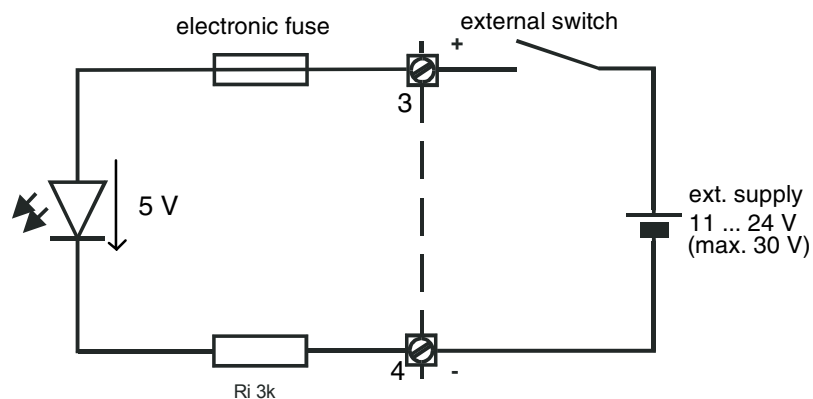

Figure 5-17 Circuit diagram of digital input 2

- **Signal type**, menu item 4.3.2
You can determine the signal type (high-active, low-active) with this.





5.3.5 Function Group Identification



Funct. unit
menu item 5.1

You can call or enter device-specific or tag-related data in this menu.





You have the following options:

- **TAG (tag number)**, menu item 5.1.1
- **Tag description**, menu item 5.1.2
- **Message**, menu item 5.1.3

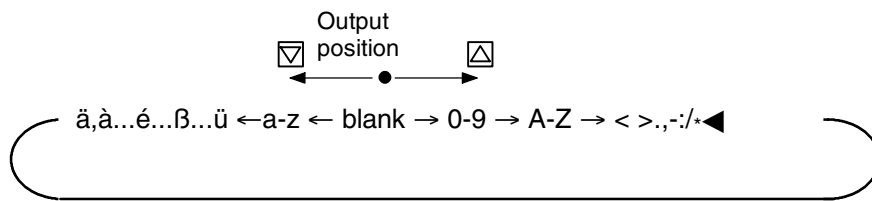
You can enter tag-specific data in these menu items. The  and  operating elements take on the function of a cursor control here. The numbers, letters and text characters are selected with the  and  operating elements.





If no text is stored, the end of text character  flashes when opening these menu items. Actuation of the  and  operating elements moves the end of text character one position to the right and a character can be selected from the character set. The following characters are available:





The selected character is transferred by pressing the  operating element and the end of text character flashes again. Another character can be selected with the  and  operating elements. Text input is ended by actuating the  operating element when the end of text character flashes.

The number of characters is limited to:



	local display	
	PROFIBUS	HART
• Tag number (TAG):	32 characters	8 characters
• Tag name:	32 characters	16 characters
• Tag message	32 characters	32 characters

The Hart communication transmits only capital letters. For texts with more than 16 characters, the marks  and  in the first and last segment of the device display respectively indicate that there are other characters to the left and/or right of the displayed text. You can display these by actuating the  and  operating elements.

You delete the text by selecting the end of text character from the character set with the  and  operating elements and then actuating the  operating element. All inputs to the right of the end of text character are then deleted.



Note !

When the  and  operating elements are actuated continuously (your finger stays on the glass panel), the characters are scrolled automatically.

- **Manufacturer data**, menu item 5.2
You can read out the serial number, order number and software version of the device in the individual menu items.
The serial number and the MRPD of the device electronics are always displayed; in case of replaced electronics the latter is different from that of the device rating plate.
- **Nominal width**, menu item 5.2.6.2
In this menu item you can set the nominal width in older generations of sensors manually if no SmartPLUG data are available.
When you have selected "Probe", you must enter the interior diameter of the surrounding tube in "Diameter".

5.3.6 Function Group Service



Enter Code
menu item 6.1

You can disable the control and display unit with a personal, freely selectable code number to prevent programming of the device by unauthorized persons. By entering the appropriate code number in this menu item, the programming is enabled and you can change the device settings.

- Factory set code "0" or
- customer code (see menu item 6.2 "Code change")



Notes !

If you actuate one of the  or  operating elements in the setting level of the parameter, you are automatically prompted to enter the code in the device display.

The programming is disabled after returning to the display mode.

The programming can also be disabled by entering any number which does not match the actual customer code in this menu item.

After input of '3333' the fixed personal code is briefly displayed (help function as reminder).

Customer Code menu item 6.2	You can change the personal code number in this menu item. The code is factory set to 0. The menu item is only accessible after entering the personal code even when programming has already been enabled.
<hr/>	
Attention!	
The programming is always enabled when the code = 0.	
<hr/>	
Service code menu item 6.3	The calibration data of the device are protected by a special code (factory code). The appropriate menu items are only available after entering this factory code.
Reset menu item 6.4	Here you can perform a "warm start" of the controller, This retains all saved units but the volume totalizer is reset to zero.
Control values menu item 6.5	These display values are for trained service personnel, since they are device-internal data mainly for error diagnosis. These include: <ul style="list-style-type: none">• Magnet voltage U_m, U_{ref} (Transmag 2 only), menu item 6.5.1• Signal voltage U_{sig}, menu item 6.5.2• Electrode voltage U_{el1}, menu item 6.5.3• Electrode voltage U_{el2}, menu item 6.5.4• Current flow in % of the set full scale value, menu item 6.5.5• Measuring frequency, menu item 6.5.6• Self test, menu item 6.5.7• Service information, menu item 6.5.8• Digital input, menu item 6.5.9
Zero Trim menu item 6.6	This function is divided into: <ul style="list-style-type: none">• Zero flow correction, menu item 6.6.1 This menu item serves to adapt the local hydraulic conditions. The zero point has a speed value of $\pm 0 \dots 1$ m/s added. This setting is undone by entering "0".• Start correction, menu item 6.6.2 This automatically determines the hydraulic zero point. This value is visible in menu item 6.6.1 and can be adapted there if necessary or undone by entering "0".

Trim param.
menu item 6.7

You have the following setting options in this menu:

- **Calibration factor**, menu item 6.7.1
Due to the local hydraulic conditions, any error related to the full scale value is corrected in this menu item. The value to be set here corresponds to a multiplier of the measured value.
An absolutely correctly set zero point is the prerequisite for proper functioning.
- **CFH**, menu item 6.7.2
This is a factory determined hydraulic calibration value at a flow of 1 m/s. This value is automatically taken from the SmartPLUG of the measuring sensor. For older measuring sensors without a SmartPLUG, the value must be transferred manually from the nameplate.
- **CFR**, menu item 6.7.2, only Transmag 2 (7ME5034):
this is a calibration value for the reference inductor in the measuring sensor calculated in the factory. This value is automatically adopted by the SmartPLUG.
- **ZPH**, menu item 6.7.3
This is a factory determined hydraulic calibration value at a flow of 0 m/s. This value is automatically taken from the SmartPLUG of the measuring sensor. For older measuring sensors without a SmartPLUG, the value must be transferred manually from the nameplate.
- **Excitation frequency**, menu item 6.7.4
This setting option depends on the type or the nominal width of the sensor or the probes.

Signal Transmitter	Sensor	Nominal width	Magnet frequency ¹
Intermag 2	711/A, ../E, ../S, ../D, ../F5	DN 2 ... 100 mm	12 Hz / f/4
	711/A, ../E, ../S, ../D	DN 125 ... 1600 mm	6 Hz / f/8
	711/A, ../E	DN >1600 mm	3 Hz / f/16
	probes S1, S2	(all)	12 Hz / f/4
	two probes S1 in series	(all)	3 Hz / f/16
	two probes S2 in series	(all)	6 Hz / f/8
Transmag 2	911/E, ../F5 standard applications	(all)	Bipolar prepulse f/5
	911/E, ../F5 Rapid applications	(all)	Bipolar f/3
	911/E up to 1995	DN ≤ 150	Unipolar f/16

¹ f = mains frequency; for DC supply, the fixed frequency given applies

Table 5-4 Magnet frequencies

- **Immersion check**, menu item 6.7.5
The "Tube empty" detection depends basically on the conductivity of the medium. The switching threshold is set to a typical value.

Adjustment may be necessary in special cases.

Here you have to determine the current internal measured values for electrodes 1 and 2 for a filled and empty measuring tube under the menu items 'Act.Value E11' and 'Act.Value E12'. The switching threshold of the immersion check should be set under menu item 'Threshold' to about midway between these two values.

5.4 PROFIBUS Communication

The following functions of the standard device (with 20 mA/HART interface) are **not** offered in the PROFIBUS version (7ME503x-1xxxx) because they are covered indirectly by the PROFIBUS function:

- Analog output (0/4 to 20mA)
- HART communication
- Digital output 2 (relay output)

The SITRANS FM InterMag 2/TransMag 2 has a PROFIBUS-PA connection compliant with IEC 1158 (synchronous transmission) which transfers data at a fixed speed of 31.25 kBit/s. The min. TSDR at startup is 11 bit times and can then be changed using the "Set_Prm" service. The bus address has the value 126 in the as-delivered state and can be changed either with the DP service "Set_Slave_Add" or on the local operating unit (menu 4.1.1). Communication via PROFIBUS takes place with the EN50170 standard (PROFIBUS DP and DP V1).

The data traffic and the data formats are described in the following sections.

The following DP services are supported as slaves for a class 1 master:

- Data_Exchange
- Rd_Inp
- Rd_Outp
- Set_Prm
- Chk_Cfg
- Slave_Diag
- Set_Slave_Add
- Global_Control
- Get_Cfg

The following DP V1 services are supported as slaves for a class 2 master DP V1 services supported as slaves:

- MSAC2_Initiate (Indication and Response)
- MSAC2_Abort (Request, Indication und Response)
- MSAC2_Read (Indication und Response)
- MSAC2_Write (Indication und Response)

5.4.1 Cyclic Data Traffic

Cyclic data transmission serves for fast exchange of useful data between a class 1 master (control system or PLC) and the slave (SITRANS FM).

Up to four different measured values (= modules) can be transmitted cyclically from the device to the control system as input data in one telegram with the "Data_Exchange" service.

The following measured values are available for selection in the given order:

1. Flow (volume or mass flow)
2. Totalizer (volume or mass) net
3. Totalizer (volume or mass) forwards
4. Totalizer (volume or mass) reverse

The output data are sent to the device with the cyclic request telegram. The number and type of actually transferred data can be determined with the aid of the configuration data (see GSD, section 5.4.1.3).

5.4.1.1 Input Data (from Slave to Master)

The input data are useful data (measured values) which are transferred from the device to the master in the following format with the "Data_Exchange" service:

Every measured value consists of 5 bytes which are made up of a floating point value according to IEEE-754 (4 bytes) for the measured value itself and the corresponding measured value status (1 byte). In the PROFIBUS telegram, the measured value is transmitted first and then the corresponding status.

Byte No.	Bit							
	7 (MSB)	6	5	4	3	2	1	0 (LSB)
1	VZ	E _{2⁷}	E _{2⁶}	E _{2⁵}	E _{2⁴}	E _{2³}	E _{2²}	E _{2¹}
2	E _{2⁰}	M _{2⁻¹}	M _{2⁻²}	M _{2⁻³}	M _{2⁻⁴}	M _{2⁻⁵}	M _{2⁻⁶}	M _{2⁻⁷}
3	M _{2⁻⁸}	M _{2⁻⁹}	M _{2⁻¹⁰}	M _{2⁻¹¹}	M _{2⁻¹²}	M _{2⁻¹³}	M _{2⁻¹⁴}	M _{2⁻¹⁵}
4	M _{2⁻¹⁶}	M _{2⁻¹⁷}	M _{2⁻¹⁸}	M _{2⁻¹⁹}	M _{2⁻²⁰}	M _{2⁻²¹}	M _{2⁻²²}	M _{2⁻²³}

VZ: sign: 0 positive, 1 negative E: Exponent M: Mantissa

Table 5-5 Measured value format

Byte No.	Bit							
	7 (MSB)	6	5	4	3	2	1	0 (LSB)
5	Quality			Substatus			Limits	

Table 5-6 Status byte format

The status bytes consist of three components:

- Quality (the MSBs 6 and 7):
describes the basic quality of the corresponding measured value
- Substatus (bits 2 to 5):
Differentiates the quality of the corresponding measured value
- Limits (the LSBs 0 and 1):
indicate exceeding of the limit value

These components may adopt the following values in SITRANS FM:

Bit 7	Bit 6	Profile Designation	Meaning
0	0	bad	Useless measured value
0	1	uncertain	Uncertain measured value
1	0	good (not cascade)	Measured value OK

Table 5-7 Formats of the quality bits

Bit 5	Bit 4	Bit 3	Bit 2	Bezeichnung	Meaning
0	0	0	1	configuration error	Error in parameterization, i.e. upper and lower value for measuring or output scale identical
0	0	1	0	not connected	Sensor error or sensor not connected
0	0	1	1	device failure	RAM or EEPROM defective; diagnostic bit "Memory error" is set additionally and diagnostic message "RAM error" or "EEPROM error" displayed locally
0	1	1	1	out of service	Corresponding function block is in "Out of service" mode (see parameter "MODE_BLK actual")
0	0	0	0	non specific	Immersion check: at least one electrode not immersed
0	0	0	1	last usable value	Failsafe operation: current measured value replaced by the last good measured value
0	0	1	0	sunstitute set	Failsafe operation: current measured value replaced by the agreed failsafe valuet
0	1	0	0	initial value	Failsafe operation or state before first measurement: actual measured value replaced by start value
0	1	0	0	sensor conversion not accurate	Measured value is outside the sensor limits
0	0	0	0	O.K.	Measured value is OK (normal state)
0	0	0	1	update event	A parameter with memory attribute "static" was changed locally or by PROFIBUS
0	0	1	0	active advisory alarm	Upper warning limit exceeded or lower warning limit dropped below
0	1	0	0	active critical alarm	Upper alarm limit exceeded or lower alarm limit dropped below

Table 5-8 Formats of the substatus bits

Bit 1	Bit 0	Profile designation	Meaning
0	0	O.K.	Measured value within the limit values (normal state)
0	1	low limited	Measured value has dropped below the lower limit (alarm, warning or sensor limit)
1	0	high limited	Measured value has exceeded upper limit (alarm, warning or sensor limit)
1	1	constant	Measured value remains constant

Table 5-9 Formats of the limit bits

Limit bits can only be clearly evaluated in combination with the quality information!

The following combinations of the values of the status byte described above are possible in normal operation (i.e. when the input value of the function block concerned incl. status is not simulated):

Value hex	Meaning			applies to			
	quality	substatus	limits	flow	total net	total forw.	total rev.
1F	bad	out of service	constant	X			
0F	bad	device failure	constant	X			
0C	bad	device failure	O.K.		X	X	X
11	bad	sensor not connected	constant	X	X	X	X
07	bad	configuration error	constant	X			
00	bad	non specific	O.K.	X	X	X	X
52	uncertain	sensor conversion not accurate	high limited	X	X	X	X
51	uncertain	sensor conversion not accurate	low limited	X	X	X	X
4F	uncertain	initial value	constant	X			
4B	uncertain	substitute set	constant	X			
47	uncertain	last usable value	constant	X			
8E	good	active critical alarm	high limited	X	X	X	X
8D	good	active critical alarm	low limited	X	X	X	X
8A	good	active advisory alarm	high limited	X	X	X	X
89	good	active advisory alarm	low limited	X	X	X	X
84	good	active update event	O.K.	X	X	X	X
80	good	O.K.	O.K.	X	X	X	X

Table 5-10 Valid combinations of the status byte

The status conditions in Table 5-10 have descending order of priority from top to bottom. If several status conditions are satisfied, the current status with the highest priority is reported.

5.4.1.2 Output Data (from Master to Slave)

The output data consist per totalizer (net, forwards and reverse) of one byte of which only the two LSBs respectively are evaluated. All other bits are not evaluated but should be set to 0 for safety. This value represents the "SET_TOT" parameter of the "Totalizer Function Block" defined in the PROFIBUS-PA profile.

Bit 1	Bit 0	Profile designation	Meaning
0	0	totalize	totalizer runningt
0	1	reset	totalizer stopped and reset to 0
1	0	preset	not implemented; command not accepted

Table 5-11 Totalizer mode of the parameter "SET_TOT"

The transferred value is effective until being changed. For example, the totalizer stays at value 0 after sending the value 1 (reset totalizer) until the "SET_TOT" parameter is changed again.

Every value of the "SET_TOT" parameters affects the corresponding totalizer independently of the others. The cumulating of measured values also takes place independently, i.e. the totalizer reading net must not correspond to the total of totalizer reading forwards and totalizer reading reverse especially when a totalizer has been reset.

Attention!

Resetting and starting of the totalizers can also be triggered parallel to cyclic communication by an acyclic command. This should be avoided at all cost because the behavior of these totalizers is then dependent on the exact chronological order of these commands.

5.4.1.3 Device Database File (GSD)

The device database file (GSD) is used to configure the format and order of the cyclic data. As an alternative to the device-specific GSD (see the appendix) the standard GSD for magnetic-inductive flow transmitters described in profile 3.0 can also be used but does not support the manufacturer-specific extensions.

The acyclic parameter "IDENT_NUMBER_SELECTOR" must be set to select the GSD (0 = profile GSD, 1 = manufacturer-specific GSD = factory setting). This can also be done on the local operating unit under menu item 4.1.2.

The GSD lists all permissible identifiers for every measured value (= module). They can be freely combined with the restriction that only one identifier may be used per module and the order of the identifiers must be the same as the order of modules.

At least one measured value must be requested, i.e. the number of identifiers must be at least 1 and 4 at the most.

The formats "resettable quantity" and "quantity" are accepted for the totalizer modules. The identifiers are checked independently of each other, i.e. when polling several measured values, combinations with different formats are permissible.

The order of measured values specified in the GSD is defined in the cyclic telegram and cannot be changed (see also section 5.4.1). If one of the four measured values is omitted, "Free Place" must be specified as an identifier.

Rules are stored in the GSD for use in the "SIMATIC S7/HW-Config" control system which prevent wrong configuration.

Example:

The measured values "Totalizer net" and "Totalizer forwards" should be transmitted. Then the following identifier combination must be specified:

1. Free Place (for flow)
2. long Identifier (for totalizer net)
3. long Identifier (for totalizer forwards)

No identifier for the totalizer reverse is necessary here because the value of the totalizer forwards is the last measured value to be transmitted.

5.4.2 Acyclic data traffic

Acyclic data transmission is mainly used for remote control of the device, i.e. for transmitting parameters during commissioning, maintenance, batch processes or for displaying other variables which do not participate in the cyclic useful data traffic.

Acyclic accesses can be made by a class 1 master (C1 connection) or a class 2 master (C2 connection). Sitrans FM supports up to four simultaneous C2 connections.

The more than 300 parameters including address (Slot and Index), format, value range, start value and attributes are stored in an object list "Obj80C4.rtf" which will be provided on request.

Acyclic operation takes place preferably with the SIMATIC PDM software package and a PC (compatible with the industrial standard) or programming device (see section 5.1).

5.4.3 Diagnostics

The diagnostic data can be requested with the "Slave_Diag" service. If extended diagnostic messages (Ext_Diag_Data) exist, this is displayed by the "Diag_Flag" of the "Data_Exchange" service. If the master then calls the "Slave_Diag" service, the external diagnostic data are supplied in the following form by the device:

Byte No.	Profile designation		Value	Meaning
1	Header		8 (dec.)	(fixed) length of diagnostic data (number of bytes)
2			254 (dec.)	(fixed)
3			1	(fixed)
4			0 or 1	Display of changes in diagnostic data (see below)
5	Diagnosis	Byte 1	(s. below)	Diagnostic information
6		Byte 2	--	(not supported)
7		Byte 3	--	(reserved)
8		Byte 4	(s. below)	Note on additional diagnostic data

Table 5-12 Format of diagnostic data

The total length of the external diagnostic data is always 8 including the header.

The "Diag_Flag" is always set when something has changed in the last four bytes of the diagnostic data (corresponds to the parameter "DIAGNOSIS") since the last message, i.e. even when diagnostic messages disappear again so that the master can register every change in the diagnostic data.

When a diagnostic message is active, the corresponding bit is set otherwise reset.

The following bits of the external diagnostic data are supported by SITRANS FM (all other bits stay reset at all times):

Bit No.	Description	Meaning
0	Error appears	at least one bit of the following 4 bytes (DIAGNOSIS) was set
1	reset	at least one bit of the following 4 bytes (DIAGNOSIS) was reset
2 ... 7	reserved	---

Table 5-13 Format of the diagnostic data, byte 4

The "Error appears" message has priority over the "Error disappears" message, i.e. if one diagnostic bit is set and another reset simultaneously, "Error appears" is reported.

The DIAGNOSIS part contains diagnostic messages of the device and has the following structure (Bit 0 = LSB, Bit 7 = MSB):

Bit No.	Description	Meaning	Cause (local message)
0	DIA_HW_ELETR	Hardware failure of the electronic	"Com.--Module failure" Communications module cannot be addressed
			Sensor failure (sensor failure)
			"Measurement module failure"
4	DIA_MEM_CHKSUM	Memory error	"Memory failure"
5	DIA_MEASUREMENT	Measurement failure	"Flow measurement failure"
			"Tube empty"
			"Measuring range overflow"

Table 5-14 Format of the diagnostic data, Byte 5 (=DIAGNOSIS Byte 1)

Bit No.	Description	Meaning	Cause (local message)
0 ... 6	reserved	---	
7	EXTENSION_AVAILABLE	More diagnosis information is available	More diagnosis information available (here: Local messages see DIAGNOSIS--Byte 1)

Table 5-15 Format of diagnostic data, Byte 8 (=DIAGNOSIS Byte 4)

The bits in DIAGNOSIS usually take over the function of a group message which can then be split up in detail using the local messages.

The EXTENSION_AVAILABLE bits indicates that other diagnostic information is available, basically details of the DIAGNOSIS message. This information is displayed locally.

The measured value-related messages are transmitted additionally cyclically with the measured values in the status byte (Substatus).

Examples for telegrams with diagnostic data (Ext_Diag_Data):
All diagnostic bits are reset in the initial state. When the "Tube empty" event occurs (byte 5, bit 5 set), this gives the following diagnostic data:

Diagnosis Byte No.	1	2	3	4	5	6	7	8
Value (hex)	08	FE	01	01	20	00	00	80
Meaning s. Table 5-12	Header				Diagnosis			

Initial state: all diagnostic bits are reset. With the occurrence of the events "Memory failure" (byte 5, bit4) and "Flow outside sensor limits" (byte 5, bit 5), this gives the following diagnostic data:

Diagnosis Byte No.	1	2	3	4	5	6	7	8
Value (hex)	08	FE	01	01	30	00	00	80
Meaning s. Table 5-12	Header				Diagnosis			

Initial state: at least one diagnostic bit is set. As soon as all diagnostic messages are reset, the following diagnostic data result:

Diagnosis Byte No.	1	2	3	4	5	6	7	8
Value (hex)	08	FE	01	02	00	00	00	80
Meaning s. Table 5-12	Header				Diagnosis			

5.4.4 Locking operation

Write access via PROFIBUS is also possible with the local operation lock activated (personal PIN, menus 6.1 and 6.2).

Operation via PROFIBUS can be locked in several steps:

- **General write protection:**
This can be activated with the PROFIBUS parameter "WRITE_LOCKING" and has the result that all parameter changes are rejected locally or by PROFIBUS.

0: The general write protection has been activated. Parameters cannot be written generally.
Exception: output data for totalizers (set, start) when they are transmitted cyclically (with the "data-exchange" service).
This write protection can be deactivated by the local operation in the case of a permanent communication failure by entering the code "2457" (menu item 6.1)

>0: The general write protection is switched off.



Note !

The consistency in the parameters between the device and the control system is decisive for correct interpretation of the cyclic measured values. In current operation, the local operating lock (menu 6.2) or "WRITE_LOCKING" should therefore be activated by PROFIBUS.

- **Hardware write protection:**
A write protection by hardware components is not implemented; the PROFIBUS parameter "HW_WRITE_PROTECTION" is not significant.
- **Locking of local operation**
Local operation can be locked by the PROFIBUS parameter "LOCAL_OP_ENABLE":

0: The local operation is completely locked, the last valid display state is retained.
In the event of a communication failure of more than 30 s, the local operation lock is cancelled automatically until communication is recovered.

1: Local operation is released.
This function may be restricted under certain circumstances by write protection "WRITE_LOCKING" or local operation lock (personal PIN, menus 6.1 and 6.2).

Maintenance and Elimination of Faults

6

6.1	Maintenance	6-2
6.2	Repairs	6-2
6.3	Elimination of Faults	6-2
6.3.1	Changing fuses	6-2
6.3.2	Error Messages	6-4
6.3.2.1	Application Problems	6-4
6.3.2.2	Troubleshooting	6-7
6.4	Cleaning	6-8

6.1 Maintenance

The Sitrans FM InterMag 2 flow transmitter including sensor is maintenance-free.

6.2 Repairs

If you send in the flow transmitter to Siemens for repair, please enclose an accompanying note with the following information (see "Application questionnaire" in chapter 7):

- Description of the measuring job
- Description of the error
- Chemical and physical properties of the medium



Warning

All residue of the medium must be removed before sending in the device. This is particularly necessary when the medium poses a health risk such as caustic, toxic, carcinogenic, radioactive etc.

Mailing address for returns from Germany:

Postal address:

Siemens AG
A&D Retouren-Center
Postfach 26 63
D-90713 Fürth
Tel.-Nr.: 0180-5050-448
Fax-Nr.: 0180-5050-449

Delivery address:

Siemens AG
A&D Retouren-Center
Siemensstraße 2-4
D-90766 Fürth

Returns from all other countries:

Postal address:

Siemens AG
A&D EC LZN
Retourenstelle
Postfach 46 52
D-90025 Nürnberg
Germany

Delivery address:

Siemens AG
A&D EC LZN
Retourenstelle
Winter-Günter-Straße 11
D-90441 Nürnberg
Germany

6.3 Elimination of Faults

6.3.1 Changing fuses



Warning

The device must be disconnected from the mains at all poles before opening it. The fuses may only be changed by qualified personnel.

Please note that these fuses can only be replaced by fuses of the same type.

The device fuse of the transmitter is on the power supply board.

The following types of fuses are used:

- Power supply AC 100 ... 230 V:
T 1.6 A / 250 V H (cutoff capacity 1500 A); 5.2 x 20
- Power supply UC 24 V:
T 2.0 A / 250 V H (cutoff capacity 1500 A); 5.2 x 20

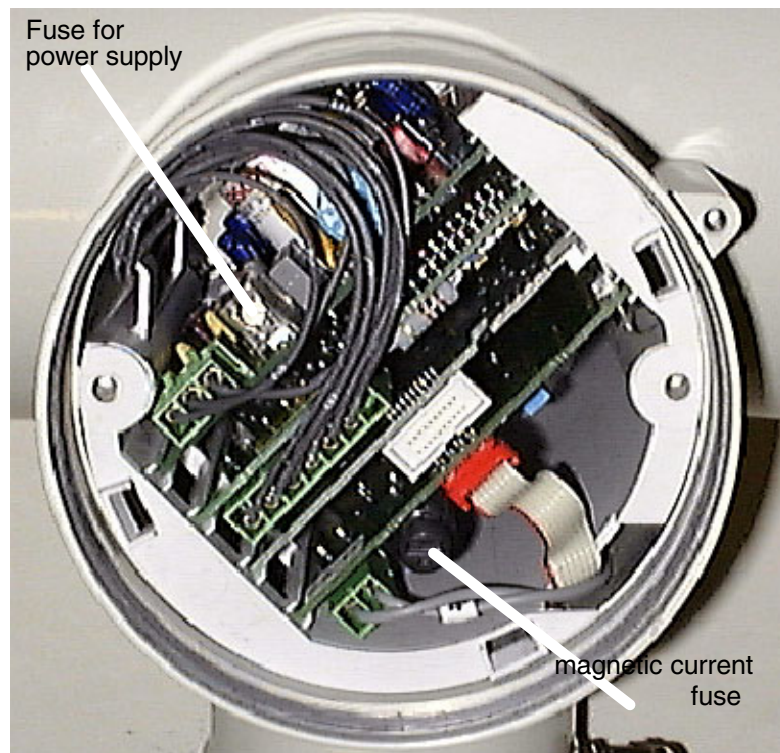

Fig. 6.1 Position of the fuses

The magnetic current fuse is on the measurement board.

The following types are used:

- Intermag 2 (7ME5033): T 400mA/250 V, IEC 127; 5,2 x 20 mm
Explosion protected devices have two fuses of this type.
- Transmag 2 (7ME5034): F 5A/250 V, IEC 127, 5,2 x 20 mm

6.3.2 Error Messages

6.3.2.1 Application Problems

Error	Diagnosis	Remedy
Sensor does not work or no display or no output signal	Power supply missing	Connect or switch on power supply
	Device fuse defective	Check device fuse and replace if necessary (see section 6.3.1)
Transmitter does not react to controls	Reflections in the glass	Clean glass
	Glass is not tight to the operating unit	Screw in the electronic cover tightly
Transmitter cannot be parameterized by the operating module	Personal code is activated	Enter personal code (menu 6.1 or deactivate by entering 0 in menu 6.2)
	Local operation lock activated by HART or PROFIBUS	Cancel operation lock (see section 5.4.4)
Output signal OK but no display visible	Ambient temperature outside permissible range	Remote design: bring transmitter into a temperature range of 0 to 50 °C
	Display defective	Change operating module
Flow display = 0 at available flow	Low flow cut set too high	Reduce low flow cut (menu 3.1.6)
	Flow opposite to preferable direction at setting of measuring direction to "forwards only"	Switch over preferred direction menu (3.1.5.1) or set measuring direction to "forw.+rev." (menu 3.1.5.2)
	Measured value set to 0 via digital input	Switch over signal at digital input (menu 4.3.2) or switch off function (menu 3.3.1)
	Cable connection to sensor defective (only for remote design)	Check cable connection and exchange as required
	SmartPLUG defective	Have SmartPLUG exchanged (only by service personnel)
Transmitter indicates flow at zero flow	Hydraulic zero point drift, application-dependent	Perform zero correction (menu 6.6.2) or enter correction value directly (menu 6.6.1)
	Earthing problems	Provide potential equalization according to section 3.2.1

Error	Diagnosis	Remedy
Fluctuating measuring results at constant flow	Air, gas occlusions	Eliminate gas occlusions or use gas trap, guarantee full level
	Earthing problems	Provide potential equalization according to section 3.2.1
	Vibrations in the sensor and/or in the cable run	Fix the sensor better, strap cables
	Medium conductivity too low	Check conductivity; measuring method may be unsuitable
	Proportion of solids too high	Reduce proportion of solids, measuring method may be unsuitable
Measuring deviations, measuring errors	Inlet and outlet lines insufficient	Change installation (see section 3.2.2)
	Highly turbulent flow profile	Change inlet line, use flow rectifier, reduce diameter of tube
	For mass measurement: medium density set incorrectly	Correct density according to current medium (menu 3.1.4)
	Hydraulic calibration values faulty	Check hydraulic calibration values CFH and ZPH. According to the sensor rating plate and correct if necessary (menus 6.7.2 and 6.7.3).
	Electric calibration faulty	Run self-test (menu 2.4.1); Check device status (menu 2.1): of "Calibration failure measuring module" is displayed, send in the complete electronics for repair
	Application-dependent calibration values faulty	Reset zero point correction (menu 6.6.1) to 0 and/or reset calibration factor (menu 6.7.1) to 1.0. Alternatively: Make zero correction (menu 6.6.2) and manual adaptation of the calibration factor (menu 6.7.1)
Measured value too low at dosing	Set attenuation too high	Reduce filter time constant (menu 3.1.7.1)
	Fault blanking activated	Deactivate noise suppression (menu 3.1.7.3)
	Magnetic field frequency too low	Device may not be suitable for this application
Measured value too low in pulsed flow	Temporary exceeding of internal working range	Increase URV (menu 3.1.2)
	Unfavorable hydraulic conditions	Install sensor on the suction side of the corresponding pump or in front of the feeding valve
Output current does not correspond to the current flow and remains at a constant value	There is a fault, failure signal 3.6, 22 or 24 mA is output (depending on the setting under menu 4.1.2)	Determine source of fault under device status (menu 2.1) (see section 5.3.2)
	Load too high	Reduce total load including the cable resistance to < 600 Ω
	Current output or power supply defective	Replace complete electronics
Communication via HART not possible	Minimum load of 230 Ω not available	Increase load to at least 230 Ω and connect HART Modem/Communicator parallel to this load

Error	Diagnosis	Remedy
Communication via PROFIBUS not possible	Device address set incorrectly (assigned more than once on the same bus or not configured in the master)	Correct address under menu 4.1.1 or request and correct by acyclic communication
	Current load on bus too high for connected feeding device	Try disconnecting other devices from the bus Adapt the feeding device if necessary
	Baud rate between master and coupler/link not correct	Adapt baud rate to coupler/link
	More than two bus terminations exist (incl. coupler and link)	Reduce to two bus terminations
	PROFIBUS interface defective	check device status (menu 2.1): if "COM module failure" is signaled, replace the complete electronics

Table 6-1 Check list for application problems

6.3.2.2 Troubleshooting

See also section 5.3.2.

1)		Error	Diagnosis	Remedy
D	Flashing "D" in the top right hand corner of the display	General device error (see also section 5.3.2)	Menu 2.1 Call device status	
		Missing mains synchronization	Menu 3.1.7.2 Switch line synchronization "Off"	
D	Device status (menu 2.1) "Memory failure"	Internal memory defective	Replace complete electronics	
D	Device status (menu 2.1) "COM Module failure"	HART interface not available in the transmitter	Replace complete electronics	
		PROFIBUS interface not available in the transmitter		
D	Device status (menu 2.1) "Software failure"	General software error	Do a restart (menu 6.4); If error persists: have firmware reloaded (by service personnel), alternatively: replace complete electronics	
D	Device status (menu 2.1) "Sensor failure"	Magnetic field current fuse defectiv	Change magnetic field current fuse (see section 6.3.1)	
		Magnetic current cable defective (at terminals 5 and 6 in remote design)	Check cable and change if necessary	
		Magnet coil defective	Check on remote design: Switch off device, disconnect magnetic field current cable, measure resistance at terminals 5 and 6 on sensor: setpoint: 8 ... 20 Ω otherwise: change sensor	
		Transmag 2 (7ME5034) only: Reference coil improperly connected (terminals 55, 66)	Check cable and replace if necessary	
		Electronics defective	Change complete electronics	
D	Device status (menu 2.1) "Flow measurement disturbed"	No measurement possible (group message)	Change complete electronics	
	"SmartPLUG read failure"	Connected sensor without SmartPLUG or defective SmartPLUG	Check parameterization (range, unit etc.) A correct measurement is still possible when the calibration values CFH and ZPH match the values on the rating plate of the sensor. Check whether this is the case and correct if necessary under the menus 6.7.2 and 6.7.3 (see also section 4.2)	

¹ Flashing error character in the top right hand corner of the local display

1)		Error	Diagnosis	Remedy
F	Flashing "F" in the top right hand corner of the display	General incorrect measurements, process errors or incorrect parameterization (see also section 5.3.2)	Menu 2.1 Call device status	
F	Device status (menu 2.1) "Measurement module failure"	Measuring range overflow	Reduce flow quantity or increase full scale value in menu 3.1.2	
F	Device status (menu 2.1) "Measurement module"	Measuring electronics defective	Measurement with reduced accuracy still possible; replace complete electronics	
		Defective immersion check	Deactivate immersion check (menu 2.3)	
		Magnetic field current outside the calibrated range	Recalibrate unit	
		Fault in measuring function (incorrect measuring frequency)	Turn off mains synchronization (menu 3.1.7.2).	
F	Device status (menu 2.1) "Calibration failure measuring module"	Self-test made with the result: measuring tolerances too high in relation to factory calibration	Electronics must be recalibrated, send in device or complete electronics or repair	
F	Device status (menu 2.1) "Simulation is running"	Device not in "Measure" status, Simulation is switched on	End simulation (exit the menu "Simulation" 2.5.2, 2.5.3 or 2.5.4 or select "End" in menu 2.5.1. Alternatively: Restart the device	
F	Device status (menu 2.1) "Calibration is running"	Zero calibration (menu 6.6.2) started and active	Device returns to measuring mode automatically at the end of calibration	
F	Device status (menu 2.1) "Tube empty" (only possible with immersion check (menu 2.3) activated)	Measuring tube empty or only partially filled	Fill measuring tube with medium, ensure it is completely full	
		High percentage of gas	Clear gas occlusions or use gas trap	
F	Device status (menu 2.1) "Flow measurement uncertain"	Electrode DC voltage outside permitted range	Clean sensor electrodes	
F	Device status (menu 2.1) "Measuring range overflow"	Current flow too high	Reduce flow	
		Full scale value set too low	Increase full scale value in menu 3.1.2 or reduce flow rate	

Table 6-2 Notes on troubleshooting

6.4 Cleaning

Use only **mild** cleaning agent to clean the transmitter. •Aggressive" agents such as hydrochloric acid (even diluted), alcohol or abrasive media may not be used.

Appendix

7

7.1	Certificates	7-2
7.1.1	CE Declarations of Conformity	7-2
7.1.2	EC-Type Examination Certificate	7-6
7.2	Application Questionnaire	7-15
7.3	Contents of the Device-specific Control System Files	7-17
7.3.1	Bitmap (Graphic Symbol)	7-17
7.3.2	GSD (Device Database File)	7-17
7.4	Literature List	7-20
7.5	List of abbreviations	7-21

7.1 Certificates

7.1.1 CE Declarations of Conformity

SIEMENS

**EG-Konformitätserklärung
EC Declaration of Conformity**

No. 1340.013-F01

Hersteller: Siemens AG
 Manufacturer:
 Anschrift: Östliche Rheinbrückenstr. 50; 76187 Karlsruhe
 Address: Bundesrepublik Deutschland
 Produkt- bezeichnung: MID Messumformer SITRANS FM Intermag 2
 mit den Messaufnehmern
 Product description: 7ME5033-xabxx-xAA0 mit a = A, B und b = A, C, D, G
 7ME57xx-%, 7ME51xx-%, 7ME52xx-%, 7ME53xx-%, 7ME5410-%, 7ME5614-%,
 7ME5001-% und 7ME5002-% mit % = xxxxx-xxxx

**Das bezeichnete Produkt stimmt in der von uns in Verkehr gebrachten Ausführung mit den Vorschriften folgender Europäischer Richtlinien überein:
 The product described above in the form as delivered is in conformity with the provisions of the following European Directives:**

- 73/23/EWG Richtlinie des Rates vom 19. Februar 1973 zur Angleichung der Rechtsvorschriften der Mitgliedstaaten betreffend elektrische Betriebsmittel zur Verwendung innerhalb bestimmter Spannungsgrenzen. (geändert durch 93/68/EWG)
Council Directive of 19 February 1973 on the harmonization of the laws of Member States relating to electrical equipment designed for use within certain voltage limits. (amended by 93/68/EEC).
- 89/336/EWG Richtlinie des Rates vom 3. Mai 1989 zur Angleichung der Rechtsvorschriften der Mitgliedstaaten über die elektromagnetische Verträglichkeit.
(geändert durch 91/263/EWG, 92/31/EWG, 93/68/EWG und 93/97/EWG).
 Council Directive of 3 May 1989 on the approximation of the laws of the Member States relating to electromagnetic compatibility. (amended by 91/263/EEC, 92/31/EEC, 93/68/EEC and 93/97/EEC)
- 94/9/EG Richtlinie des Europäischen Parlaments und des Rates vom 23. März 1994 zur Angleichung der Rechtsvorschriften der Mitgliedstaaten für Geräte und Schutzsysteme zur bestimmungsgemässen Verwendung in explosionsgefährdeten Bereichen.
Directive of the European Parliament and the Council of 23 March 1994 on the approximation of the laws of the Member States concerning equipment and protective systems intended for use in potentially explosive atmospheres.
- 97/23/EG Richtlinie des Europäischen Parlaments und des Rates vom 29. Mai 1997 über Druckgeräte
Directive of the European Parliament and the Council of 29. Mai 1997 on the approximation of the laws of the Member States concerning pressure equipment.

CE-Kennzeichnung / CE marking : 05/2003

Karlsruhe, den / the 21.05.03

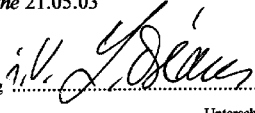
Siemens AG
 Oreans, Entwicklung 
 Name, Funktion
 Name, function

Unterschrift
 signature

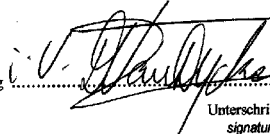
van Dycke, Fertigung 
 Name, Funktion
 Name, function

Unterschrift
 signature

Anhang A ist integraler Bestandteil dieser Erklärung
 Annex A is integral part of this declaration
 Diese Erklärung bescheinigt die Übereinstimmung mit den genannten Richtlinien, ist jedoch keine Zusicherung von Eigenschaften.
 Die Sicherheits Hinweise der mitgelieferten Produktdokumentation sind zu beachten.
 This declaration certifies the conformity to the specified directives but contains no assurance of properties. The safety documentation accompanying the product shall be considered in detail.

SIEMENS

Anhang A zur EG-Konformitätserklärung Annex A to the EC Declaration of Conformity

No. 1340.013-F01

Produktbezeichnung: MID Messumformer SITRANS FM Intermag 2
 7ME5033-xabxx-xAA0 mit a = A, B und b = A, C, D, G
 Product description mit den Messaufnehmern
 7ME57xx-%, 7ME51xx-%, 7ME52xx-%, 7ME53xx-%, 7ME5410-%, 7ME5614-%,
 7ME5001-% und 7ME5002-% mit % = xxxxx-xxxx

Die Konformität mit den auf Blatt 1 angeführten Richtlinien wird nachgewiesen durch die Einhaltung folgender Normen (variantenabhängig):
 Conformity to the directives indicated on page 1 is assured through the application of the following standards (depending on versions):

Richtlinie Directive	Norm/Referenznummer Standard/Reference number	Ausgabedatum Edition
89/336/EG:	EN 61326/A1 Anh. A	1998
73/23/EG:	EN 61010	1993

Richtlinie Directive 94/9/EG:	Norm/Referenznr. Standard/Reference no.	Ausgabe Edition	Messumformer Transmitter 7ME5033-xabxx-xAA0		Messaufnehmer Sensor 7ME57px-cdxxg-xxxxm 7ME570x-xdxx0-xxxxm 7ME577x-xdxxg-xxxxm				
			a =	b =	c =	d =	g =	m =	p =
	EN 50014+A1+A2	1997	A, B	C, D, G	1	A...P	1, 3	1	1...4
	EN 50018	2000	A, B	C, D, G					
	EN 50019	2000	A, B	C, D, G	1	A...P	1, 3	1	1...4
	EN 50020	1994	A, B	C, D, G	1	A...P	1, 3	1	1...4
	EN 50028	1987	A, B	D, G					
Zertifikat/Certificate	BVS 03 ATEX E 108 X								

Richtlinie Directive 97/23/EG:	Norm/Referenznummer Standard/Reference number	Ausgabe Edition	Messaufnehmer Sensor 7ME57px-xxxxx-xxxx-xxx 7ME5nxx-xxxxx-xxxx-xxx		
			p =	n =	Nennweite
Gas 1; SEP	AD-2000 Merkblätter (A4)	2000/2001	0, 1, 2, 3, 4, 7	1, 2, 3	≤ DN 25
Gas 1; Modul H	AD-2000 Merkblätter (A4)	2000/2001	0, 1, 2, 3, 4, 7	1, 2, 3	≥ DN 25
Zertifikat/Certif.	07 202 0111 Z 0034/1/0001 TÜV Nord				

Diese Erklärung bescheinigt die Übereinstimmung mit den genannten Richtlinien, ist jedoch keine Zusicherung von Eigenschaften.
 Die Sicherheitshinweise der mitgelieferten Produktdokumentation sind zu beachten.
 This declaration certifies the conformity to the specified directives but contains no assurance of properties. The safety documentation accompanying the product shall be considered in detail.

2 / 2

SIEMENS

EG-Konformitätserklärung EC Declaration of Conformity

No. 1345.000

Hersteller: Siemens AG
 Manufacturer:
 Anschrift: Östliche Rheinbrückenstr. 50; 76187 Karlsruhe
 Address: Bundesrepublik Deutschland
 Produktbezeichnung: Magnetisch induktiver Durchflussmessumformer SITRANS FM Transmag 2
 Product description: 7ME5034-xAAxx-xAA0 mit Messaufnehmern SITRANS FM 911/F5 und 911/E 7ME5613 und 7ME5axb mit a = 1, 2, 3 und b = 1, 3

Das bezeichnete Produkt stimmt in der von uns in Verkehr gebrachten Ausführung mit den Vorschriften folgender Europäischer Richtlinien überein:
 The product described above in the form as delivered is in conformity with the provisions of the following European Directives:

- 73/23/EWG Richtlinie des Rates zur Angleichung der Rechtsvorschriften der Mitgliedstaaten betreffend elektrische Betriebsmittel zur Verwendung innerhalb bestimmter Spannungsgrenzen. (geändert durch RL 93/68/EWG des Rates)
Council Directive on the harmonization of the laws of Member States relating to electrical equipment designed for use within certain voltage limits. (amended by Directive 93/68/EEC of the council).
- 89/336/EWG Richtlinie des Rates zur Angleichung der Rechtsvorschriften der Mitgliedstaaten über die elektromagnetische Verträglichkeit.
(geändert durch RL 91/263/EWG, 92/31/EWG, 93/68/EWG des Rates)
 Council Directive on the approximation of the laws of the Member States relating to electromagnetic compatibility. (amended by Directive 91/263/EEC, 92/31/EEC, 93/68/EEC of the council)
- 97/23/EG Richtlinie des Europäischen Parlaments und des Rates vom 29. Mai 1997 über Druckgeräte
Directive of the European Parliament and the Council of 29. Mai 1997 on the approximation of the laws of the Member States concerning pressure equipment.

CE-Kennzeichnung / CE marking: 11/2003

Karlsruhe, den / the 24.11.03

Siemens AG

Oreans, Entwicklung

Name, Funktion
 Name, function

Unterschrift
 signature

Bruno J. J. J.

von Dücke, Fertigung

Name, Funktion
 Name, function

Unterschrift
 signature

Anhang A ist integraler Bestandteil dieser Erklärung

Annex A is integral part of this declaration

Diese Erklärung bescheinigt die Übereinstimmung mit den genannten Richtlinien, ist jedoch keine Zusicherung von Eigenschaften.

Die Sicherheitshinweise der mitgelieferten Produktdokumentation sind zu beachten.

This declaration certifies the conformity to the specified directives but contains no assurance of properties. The safety documentation accompanying the product shall be considered in detail.

1 / 2

SIEMENS

Anhang A zur EG-Konformitätserklärung Annex A to the EC Declaration of Conformity

No. 1345.000

Produkt-
bezeichnung: Magnetisch induktiver Durchflussmessumformer SITRANS FM Transmag 2
7ME5034-xAAxx-xAA0
Product
description mit Messaufnehmern SITRANS FM 911/F5 und 911/E
7ME5613 und 7ME5axb mit a = 1, 2, 3 und b = 1, 3

Die Konformität mit den auf Blatt 1 angeführten Richtlinien wird nachgewiesen durch die Einhaltung folgender Normen:

Conformity to the Directives is assured through the application of the following standards:

Richtlinie Directive	Norm/Referenznummer Standard/Reference number	Ausgabedatum Edition	
89/336/EWG	EN 61326/A2 Anh. A	2001	
73/23/EWG	EN61010 Teil 1	2001	
97/23/EG			
Gas 1; SEP	AD-2000 Merkblätter (A4)	2000/2001	7ME5axx, a=1, 2, 3, Nennweite ≤ DN25
Gas 1; Modul H	AD-2000 Merkblätter (A4)	2000/2001	7ME5axx, a=1, 2, 3, Nennweite > DN25

Zertifikat / Certificate: 07 202 0111 Z 0034/1/0001 TÜV Nord

Diese Erklärung bescheinigt die Übereinstimmung mit den genannten Richtlinien, ist jedoch keine Zusicherung von Eigenschaften.
Die Sicherheitshinweise der mitgelieferten Produktdokumentation sind zu beachten.
This declaration certifies the conformity to the specified directives but contains no assurance of properties. The safety documentation accompanying the product shall be considered in detail.

2 / 2

7.1.2 EC-Type Examination Certificate



- (1) **EC-Type Examination Certificate**
- (2) **- Directive 94/9/EC -**
Equipment and protective systems intended for use
in potentially explosive atmospheres
- (3) **BVS 03 ATEX E 108 X**
- (4) **Equipment:** Flow Transmitter Type SITRANS FM Intermag 2 7ME 5033***
 and Sensor Type SITRANS FM 711/A 7ME57***
- (5) **Manufacturer:** Siemens AG
- (6) **Address:** D - 76162 Karlsruhe
- (7) The design and construction of this equipment and any acceptable variation there of are specified in the schedule to this type examination certificate.
- (8) The certification body of EXAM BBG Prüf- und Zertifizier GmbH, notified body no. 0158 in accordance with Article 9 of the Directive 94/9/EC of the European Parliament and the Council of 23 March 1994, certifies that this equipment has been found to comply with the Essential Health and Safety Requirements relating to the design and construction of equipment and protective systems intended for use in potentially explosive atmospheres, given in Annex II to the Directive.
 The examination and test results are recorded in the test and assessment report BVS PP 03.2108 EG.
- (9) The Essential Health and Safety Requirements are assured by compliance with:
- | | |
|----------------------|--------------------------|
| EN 50014:1997 +A1-A2 | General requirements |
| EN 50018:2000 | Flameproof enclosure 'd' |
| EN 50019:2000 | Increased safety 'c' |
| EN 50020:1994 | Intrinsic safety 'i' |
| EN 50028:1987 | Encapsulation 'm' |
- (10) If the sign "X" is placed after the certificate number, it indicates that the equipment is subject to special conditions for safe use specified in the schedule to this certificate.
- (11) This EC-Type Examination Certificate relates only to the design, examination and tests of the specified equipment in accordance to Directive 94/9/EC.
 Further requirements of the Directive apply to the manufacturing process and supply of this equipment. These are not covered by this certificate
- (12) The marking of the equipment shall include the following:

⊕ II 2G EEx de [ia] IIC T3/T4/T6 or EEx dem [ia] IIC T3/T4/T6
and EEx e [ia] IIC T3/T4/T6 for the sensor

EXAM BBG Prüf- und Zertifizier GmbH
 Essen, 13th June 2003

signed: Wittler

signed: Schumann

EXAM Certification body

Head of special services unit

Page 1 of 9 to BVS 03 ATEX E 108 X
 This certificate may only be reproduced in its entirety and without change
 Dinnendahlstrasse 9 44809 Bochum Germany Telefon-Phone +49 201/172-3947 Telefax-Fax +49 201/172-3948
 (until 31.05.2003: Deutsche Montan Technologie GmbH, Am Technologiepark 1, 45307 Essen Germany)



(13) Appendix to

(14) **EC-Type Examination Certificate**

BVS 03 ATEX E 108 X

(15) 15.1 Subject and type

Flow transmitter SITRANS FM Intermag 2

Type 7 ME 5033 – abcde - fAA0

- a: 0 = 20mA / HART
 1 = PROFIBUS-PA
 2 = 20mA / HART / Digital input
 only connected to type number c – C,D
- b: A = AC 100 – 230 V
 B = UC 24 V
- c: C = EEx de [ia] Process signals not intrinsically safe,
 Terminal box for power supply / process signals flameproof
 D = EEx dem [ia] Process signals not intrinsically safe,
 Terminal box for power supply / process signals increased safety
 G = EEx dem [ia] Process signals intrinsically safe,
 Terminal box for power supply / process signals increased safety,
 only in conjunction with type number b = B
- d: 0 = without control and display unit
 1 = with control and display unit
- e: 1 = remote design
 2 = compact design
- f: 1 = with cable glands M20x1,5
 2 = with cable glands 1/2" NPT

Sensor SITRANS FM 711/A, hard rubber liner

Type 7 ME 57 ab – 1defg – hik1 - z

Sensor SITRANS FM 711/A, Novolak liner

Type 7 ME 577 a - bdefg – hik1 - z

Sensor SITRANS FM 711/A, PTFE liner

Type 7 ME 570 a – bdef 0 – hik1 - z

- b: Design 1 = Compact version
 2 = Remote version

all further identifications refer to the mechanical design variants.

Page 2 of 9 to BVS 03 ATEX E 108 X
 This certificate may only be reproduced in its entirety and without change
 Dindoendahlstrasse 9 44809 Bochum Germany Telefon-Phone +49 201/172-3947 Telefax-Fax +49 201/172-3948
 (until 31.05.2003: Deutsche Montan Technologie GmbH, Am Technologiepark 1, 45307 Essen Germany)



15.2 Description

The SITRANS FM InterMag 2 7ME 5033*** is a transmitter for flow measurements and consists of the two main components, the transmitter and the sensor. These components are used for the evaluation and transmission of electrical signals. This happens either through an intrinsically safe / not intrinsically safe 4-20 mA or an intrinsically safe PROFIBUS-PA interface.

The transmitter can be connected to the SITRANS FM 711/A 7ME57*** sensor as a compact version and also as a remote version.

With the remote version the devices are connected to each other by leads. Neither the leads nor the interconnection are part of the test protocol.

15.3 Parameters

15.3.1 Supply voltage

15.3.1.1 Type 7ME 5033-*A***- *AA0

(terminals 1 and 2)

Voltage	U	AC	265	V
Nominal power			ca. 10	W
Not in conjunction with intrinsically safe process outputs				

15.3.1.2 Type 7ME 5033-*B***- *AA0

(terminals 1 and 2)

Voltage	U_m	DC	30	V
Nominal power		AC	26,4	V
			ca. 10	W

15.3.1.3 With the remote version for the output circuits (terminals 5 and 6)

Voltage	U	AC	15	V
Nominal current			300	mA

with the remote version for the transmitter interface

in the type of protection EEx ia,
only to connect to certified sensors of the SITRANS FM - series

Sensor supply circuit and signal circuit (terminals 29,30,21,22, 23, 24)

Voltage	U_o		13	V
Current	I_o		36	mA
Power	P_o		297	mW
max. external capacitance	C_o		500	nF
max. external inductance	L_o		15	mH



15.3.2 Output signals

- 15.3.2.1 Type 7ME 5033-0*C**- *AA0 and Type 7ME 5033-2*C**- *AA0
Type 7ME 5033-0*D**- *AA0 and Type 7ME 5033-2*D**- *AA0

Analog output AA, 4-20 mA with HART (terminals 7 and 8), not intrinsically safe

max. Voltage U 23 V

- 15.3.2.2 Type 7ME 5033-0BG**- *AA0

Analog output AA, 4 - 20 mA with HART (terminals 7 and 8)
in the type of protection EEx ia IIC/IIB or EEx ib IIC/ IIB

Voltage U_o 15,8 V
Current I_o 64 mA
Power P_o 253 mW
Internal resistance R_i 250 Ω

Linear characteristic

Maximum external capacitance C_o and maximum external inductance

inductance L_o	capacitance C_o	
	IIB	IIC
0	2880nF	470 nF

capacitance C_o	inductance L_o	
	IIB	IIC
0	30 mH	7,8 mH

Mixed circuits

inductance L_o in mH	capacitance C_o	
	IIB in μ F	IIC in nF
0,5	2,5	350
2	1,5	300

The mixed values have been graphically determined from the ThEx10 of the PTB, they only apply to concentrated inductivities or capacities

resp.

in the type of protection EEx ia IIC/IIB or EEx ib IIC/IIB only to connect to a certified intrinsically safe electrical circuit

Voltage U_i 23 V
Current I_i 40 mA
Power P_i 70 mW
effective internal capacitance C_i 1,7 nF
effective internal inductance L_i 108 μ H

- 15.3.2.3 Type 7ME 5033-**C**- *AA0 and Type 7ME 5033-**D**- *AA0

Digital output DAI (terminals 5 and 6)

Voltage U DC 30 V
Current 200 mA

Page 4 of 9 to BVS 03 ATEX E 108 X

This certificate may only be reproduced in its entirety and without change

Dinnendahlstrasse 9 44809 Bochum Germany Telefon-Phone +49 201/172-3947 Telefax-Fax +49 201/172-3948
(until 31.05.2003: Deutsche Montan Technologie GmbH, Am Technologiepark 1, 45307 Essen Germany)



15.3.2.4 Type 7ME 5033-0BG**- *AA0

Digital output DA1 (terminals 5 and 6)
in the type of protection EEx ia IIC/IIB or EEx ib IIC/ IIB

Voltage	U_o	7,2 V
Current	I_o	2,2 mA
Power	P_o	4 mW

Linear characteristic

For IIC

maximum external capacitance	C_o	13,5 μ F
maximum external inductance	L_o	1 H

For IIB

maximum external capacitance	C_o	240 μ F
maximum external inductance	L_o	1 H

or

in the type of protection EEx ia IIC/IIB or EEx ib IIC/IIB only connect to a certified intrinsically safe electrical circuit

Voltage	U_i	30 V
Current	I_i	100 mA
Power	P_i	750 mW

effective internal capacitance	C_i	1 nF
effective internal inductance	L_i	100 μ H

15.3.2.5 Type 7ME 5033-1BG**- *AA0

Digital output DA1 (terminals 5 and 6)
in the type of protection EEx ia IIC/IIB or EEx ib IIC/ IIB

Voltage	U_o	28,4 V
Current	I_o	2,6 mA
Power	P_o	19 mW

Linear characteristic

For IIC

maximum external capacitance	C_o	79 nF
maximum external inductance	L_o	1 H

For IIB

maximum external capacitance	C_o	630 nF
maximum external inductance	L_o	1 H

or

in the type of protection EEx ia IIC/IIB or EEx ib IIC/IIB only connect to a certified intrinsically safe electrical circuit

Voltage	U_i	30 V
Current	I_i	100 mA
Power	P_i	750 mW

effective internal capacitance	C_i	1,7 nF
effective internal inductance	L_i	108 μ H

Page 5 of 9 to BVS 03 ATEX E 108 X

This certificate may only be reproduced in its entirety and without change

Dinnendahlstrasse 9 44809 Bochum Germany Telefon-Phone +49 201/172-3947 Telefax-Fax +49 201/172-3948
(until 31.05.2003: Deutsche Montan Technologie GmbH, Am Technologiepark 1, 45307 Essen Germany)



15.3.2.6 Type 7ME 5033-0*C**-*AA0 and Type 7ME 5033-0*D**-*AA0

Digital output DA2 (terminals 3 and 4)

max. input voltage	U		50	V
max. input current			200	mA

15.3.2.7 Type 7ME 5033-0BG**-*AA0

Digital output DA2 (terminals 3 and 4) in the type of protection EEx ia IIC/IIB or EEx ib IIC/ IIB only connect to a certified intrinsically safe electrical circuit

Voltage	U_i		30	V
Current	I_i	DC	100	mA
		AC	50	mA
effective internal capacitance	C_i		1,7	nF
effective internal inductance	L_i		108	μ H

15.3.2.8 Type 7ME 5033-2*C**-*AA0 and Type 7ME 5033-2*D**-*AA0

Digital input DI (terminals 3 and 4)

max. input voltage	U_μ	DC	30	V
max. input current			10	mA

15.3.2.9 Type 7ME 5033-1*C**-*AA0 and Type 7ME 5033-1*D**-*AA0

PROFIBUS PA (terminals 7 and 8)

max. input voltage	U_m	DC	32	V
max. input current			15	mA

15.3.2.10 Type 7ME 5033-1BG**-*AA0

PROFIBUS PA (terminals 7 and 8), in the Type of protection EEx ia IIC/IIB or EEx ib IIC/IIB only to connect to a certified intrinsically safe circuit (e.g. FISCO-supply) with the maximum values according to the following table

	FISCO-supply ia/ib Group IIB/IIC	Linear barrier ia/ib Group IIB/IIC
U_o	17,5 V	24 V
I_o	380 mA	250 mA
P_o	5,32 W	1,2 W
L_i	$\leq 10 \mu$ H	
C_i	negligible	

Page 6 of 9 to BVS 03 ATEX E 108 X

This certificate may only be reproduced in its entirety and without change.
 Dinnendahlstrasse 9 44809 Bochum Germany Telefon-Phone +49 201/172-3947 Telefax-Fax +49 201/172-3948
 (until 31.05.2003: Deutsche Montan Technologie GmbH, Am Technologiepark 1, 45307 Essen Germany)



15.3.3 Sensor type SITRANS FM 711/A with the remote version

Supply connection Coil circuit

only connects to the certified transmitters in the SITRANS FM Intermag - series

Voltage	U_m	AC	15	V
Nominal current			680	mA

Sensor supply circuit and signal circuit (terminals 29,30 23, 24)

only connects to the certified transmitters in the SITRANS FM - series

Voltage	U_i		13	V
Current	I_i		36	mA
Power	P_i		297	mW
effective internal capacitance	C_i		200	nF
effective internal inductance	L_i		negligible	

15.3.4 Temperature class assignment depends on the medium temperature.

15.3.4.1 Compact version, transmitter Intermag 2 with sensor type SITRANS FM 711/A with measuring tube lining of PTFE or Novolak

Nominal width	Permissible medium temperature in °C with ambient temperature range of -20 °C to + 40 °C			Permissible medium temperature in °C with ambient temperature range of -20 °C to + 60 °C	
	T6	T4	T3	T4	T3
DN 15 to 80	-	109	130	60	60
DN 100 to 150	65	125	130	60	60
DN 200 to 300	80	130	130	60	60

15.3.4.2 Compact version, transmitter Intermag 2 with sensor type SITRANS FM 711/A with measuring tube lining of hard rubber

Nominal width	Permissible medium temperature in °C with ambient temperature range of -20 °C to + 40 °C			Permissible medium temperature in °C with ambient temperature range of -20 °C to + 60 °C	
	T6	T4	T3	T4	T3
DN 15 to 80	-	90	90	60	60
DN 100 to 150	65	90	90	60	60
DN 200 to 300	80	90	90	60	60

15.3.4.3 Sensor type SITRANS FM 711/A with measuring tube lining of PTFE or Novolak with remote transmitter Intermag 2

Nominal width	Permissible medium temperature in °C with ambient temperature range of -20 °C to + 40 °C			Permissible medium temperature in °C with ambient temperature range of -20 °C to + 60 °C	
	T6	T4	T3	T4	T3
DN 15 to 80	-	109	130	103	130
DN 100 to 150	-	125	130	120	130
DN 200 to 300	-	130	130	130	130

Page 7 of 9 to BVS 03 ATEX E 108 X

This certificate may only be reproduced in its entirety and without change
 Dinnendahlstrasse 9 44809 Bochum Germany Telefon-Phone +49 201/172-3947 Telefax-Fax +49 201/172-3948
 (until 31.05.2003: Deutsche Montan Technologie GmbH, Am Technologiepark 1, 45307 Essen Germany)



15.3.4.4 Sensor type SITRANS FM 711/A with measuring tube lining of hard rubber with remote transmitter Intermag 2

Nominal width	Permissible medium temperature in °C with ambient temperature range of -20 °C to + 40 °C			Permissible medium temperature in °C with ambient temperature range of -20 °C to + 60 °C	
	T6	T4	T3	T4	T3
DN 15 to 80	-	90	90	90	90
DN 100 to 150	-	90	90	90	90
DN 200 to 300	-	90	90	90	90

15.3.4.5 Transmitter Intermag 2 with remote sensor type SITRANS FM 711/A

Permissible ambient temperature range	Temperature class
-20 °C to + 60 °C	T6

(16) Test and assessment report
BVS PP 03.2108 EG, as of 13.06.2003

(17) Special conditions for safe use

- 17.1 It has to be made sure that the medium to be measured doesn't have any damaging effects on the sensor materials.
- 17.2 The transmitter is suitable for use in an ambient temperature range of -20 °C to +60 °C. It has to be made sure that the boundary conditions fixed in 15.3.4 are met with regard to ambient temperature, medium temperature and temperature class.
- 17.3 Along the intrinsically safe circuits the equipotential bonding must be ensured, the transmitter must be integrated with the equipotential bonding.
- 17.4 The transmitter may be operated with potentially explosive atmospheres within the measuring tube only under atmospheric conditions (pressure range of 0.8 bar to 1.1 bar).
- 17.5 The flow transmitter should be used with a 4A nominal rate fuse with a switching capability of 1500A.
- 17.6 If the equipment is of the type of protection EEx dem [ia] IIC T3/T4/T6 short opening of the terminal box for power supply and process signals with energized field wires is permitted. The terminals of the intrinsically safe output circuits (DA1/DA2/AA) are marked as intrinsically safe.



We confirm the correctness of the translation from the German original.
In the case of arbitration only the German wording shall be valid and binding.

44809 Bochum,
BVS-Ld/Mi E 1608

EXAM BBG Prüf- und Zertifizier GmbH



Certification body



Special services unit

7.2 Application Questionnaire

To Siemens Karlsruhe A&D PI 1 MS Tel.: 0049-721-595-2933/4473 Fax: 0049-721-595-2063	From company Tel.: Fax:
--	-----------------------------------

Technical process data:

Description of the liquid	Chemical formula	
	Name of liquid	
	Concentration	
	Density	
	Viscosity at 20°C [mPa s]	
	Viscosity at process temperature	
Nominal flow		
Process temperature		
Ambient temperature		
Pressure		
Solid part/particle size		
Conductivity		

Sensor data: (please enclose installation drawing)

Serial no.		
Sensor type	e. g. MG 711/A	
Nominal width	in mm/inch	DN ..
Cladding	e.g. hard rubber	
Electrode material	e.g. stainless steel 1.4571	
Length of inlet line	in mm	
Length of outlet line	in mm	

Testing the SITRANS FM InterMag 2 transmitter

Type		<input type="checkbox"/> InterMag 2 <input type="checkbox"/> TransMag 2
Serial no.		
Device status	Possible error messages in the menu item 2.1	
	Memory failure	
	COM module failure	
	Software error	
	Local display failure	
	Measuring module failure	
	Calibration failure	
	Simulation is running	
	Calibration is running	
	Sensor failure	
	Tube empty	
	Flow measurement uncertain	
	Flow measurement disturbed	
	Range overflow > 110%	
Self test	in menu 2.4.1	
Filter time constant	in menu 3.1.7.1	
Line synchronization	in menu 3.1.7.2	
Noise suppress	in menu 3.1.7.3 Suppression time	
	in menu 3.1.7.3 Tolerance band	
Flow URV	in menu 3.1.2	
Engr. Unit	in menu 3.1.1	
Nominal diameter	in menu 5.2.6.2	
Voltage U_m	in menu 6.5.1	
Voltage U_{sig}	in menu 6.5.2	
Voltage U_{el1}	in menu 6.5.3	
Voltage U_{el2}	in menu 6.5.4	
Measuring frequency	in menu 6.5.6	
Self test	in menu 6.5.7 Zero point	
	in menu 6.5.7 at "•FS"	
Service info	in menu 6.5.8	

7.3 Contents of the Device-specific Control System Files

The following files (GSD and bitmap) can be downloaded from the internet using the address http://www.ad.siemens.de/csi_e/gsd

These files are also implemented in the device install files for SIMATIC PDM software.

7.3.1 Bitmap (Graphic Symbol)



7.3.2 GSD (Device Database File)

```

;*****
;**                                                                 **
;**          GSD Datei für SITRANS FM, SIEMENS AG                 **
;**          MLFB: 7ME503*-1****_****                            **
;**          Stand: 31.07.2001                                     **
;**          SIEM80C4.GSD                                         **
;*****

#Profibus_DP
GSD_Revision          = 3
Vendor_Name           = "SIEMENS AG"
Model_Name            = "SITRANS FM"
Revision              = "Revision 01"
Ident_Number          = 0x80C4
Protocol_Ident        = 0
Station_Type          = 0
FMS_supp              = 0
Hardware_Release      = "A01"
Software_Release      = "Z01"
Bitmap_Device         = "SIE80C4n"
31.25_supp            = 1
45.45_supp            = 1
93.75_supp            = 1
MaxTsdR_31.25         = 100
MaxTsdR_45.45         = 250
MaxTsdR_93.75         = 1000
Redundancy            = 0
Repeater_Ctrl_Sig    = 0
24V_Pins              = 0
Freeze_Mode_supp     = 0
Sync_Mode_supp       = 0
Auto_Baud_supp       = 0
Set_Slave_Add_supp   = 1
Min_Slave_Intervall  = 200
Modular_Station      = 1

```

```

Max_Module           = 4
Max_Input_Len       = 20
Max_Output_Len      = 3
Max_Data_Len        = 23
Fail_Safe           = 0
Slave_Family        = 12
Max_Diag_Data_Len   = 20

;----- Description of device related diagnosis: -----
;
Unit_Diag_Bit(16)    = "Error appears"
Unit_Diag_Bit(17)    = "Error disappears"
Unit_Diag_Bit(24)    = "Hardware failure electronics"
Unit_Diag_Bit(25)    = "Hardware failure mechanics"
Unit_Diag_Bit(26)    = "Motor temperature too high"
Unit_Diag_Bit(27)    = "Electronic temperature too high"
Unit_Diag_Bit(28)    = "Memory error"
Unit_Diag_Bit(29)    = "Measurement failure"
Unit_Diag_Bit(30)    = "Device not initialized"
Unit_Diag_Bit(31)    = "Device initialization failed"
Unit_Diag_Bit(32)    = "Zero point error"
Unit_Diag_Bit(33)    = "Power supply failed"
Unit_Diag_Bit(34)    = "Configuration invalid"
Unit_Diag_Bit(35)    = "Restart"
Unit_Diag_Bit(36)    = "Coldstart"
Unit_Diag_Bit(37)    = "Maintenance required"
Unit_Diag_Bit(38)    = "Characteristics invalid"
Unit_Diag_Bit(39)    = "Ident_Number violation"
Unit_Diag_Bit(55)    = "Extension Available"

User_Prm_Data_Len   = 0

;===== Description of modules =====
;
; Use always the module order specified in this file.
; Use exactly one identifier per module.
; If you don't want to get the measuring value of a certain module
; from the device with the input data, use Free place for this module
; instead of another identifier.
;
; For the module 1 you have the choice between these different
; identifiers:
;
; - Free Place
; - Short identifier format (identifier byte)
; - Long identifier format (extended identifier)
;
; For the modules 2, 3 and 4 you have the choice between these
; different identifiers:
;
; - Free Place
; - Long identifier format (extended identifier)
; - Long identifier format, resettable (extended identifier)
;

```

```

; With the "resettable" format it is possible to reset the totalizer,
; transmitting suitable output data to the device.

;-----
; Free place - usable for each module instead of another identifier
;-----
Module = "Free place"           0x00
0
EndModule
;-----
; Module 1 - Flow
;-----
Module = "Flow"                 0x94
1
EndModule
;-----
; Module 2 - Quantity net
;-----
Module = "Quantity net"        0x41, 0x84, 0x85
2
EndModule

Module = "Resettable quantity net" 0xC1, 0x80, 0x84, 0x85
3
EndModule
;-----
; Module 3 - Quantity forward
;-----
Module = "Quantity forward"     0x41, 0x84, 0x85
4
EndModule

Module = "Resettable quant. forw." 0xC1, 0x80, 0x84, 0x85
5
EndModule
;-----
; Module 4 - Quantity reverse
;-----
Module = "Quantity reverse"     0x41, 0x84, 0x85
6
EndModule

Module = "Resettable quant. rev." 0xC1, 0x80, 0x84, 0x85
7
EndModule
;-----
;SlotDefinition
;-----
SlotDefinition
Slot(1) = "Flow"                1 0,1 ;Default am zykl. Verkehr
Slot(2) = "Quantity net"        2 0,2,3 ;Default am zykl. Verkehr
Slot(3) = "Quantity forward"    0 0,4,5 ;Default nicht am zykl. Verkehr
Slot(4) = "Quantity reverse"    0 0,6,7 ; Default nicht am zykl. Verkehr
EndSlotDefinition

```

7.4 Literature List

- /1/ PROFIBUS: Brief Technical Description <http://www.profibus.com/download.html>
- /2/ PROFIBUS PA - Profiles for Process Control Devices General Requirements V 3.0
- /3/ PROFIBUS PA - Profiles for Process Control Devices Data Sheet Transmitter V 3.0

This literature is published by:

PROFIBUS Nutzer-Organisation
PNO - Geschäftsstelle
Haid-und-Neu-Str. 7
76131 Karlsruhe

<http://www.profibus.com>

7.5 List of abbreviations

GSD:	Device database file
LSB:	Least significant Bit
MSB:	Most Significant Bit
PDM:	Process Device Manager
PNO:	PROFIBUS user organization
PROFIBUS PA:	Process Fieldbus for Process Automation



Siemens AG
Automation and Drives
Process Instrumentation and Analytics
D-76181 Karlsruhe