

SmartLine Temperature Transmitter Quick Start Installation Guide

34-TT-25-04, Revision 1

This document provides descriptions and procedures for the Quick Installation of Honeywell's family of SmartLine Temperature Transmitters.

The SmartLine Temperature Transmitter is available in a variety of models for measuring RTD Ohm Temperature.

For full details refer to the SmartLine Temperature Transmitter manuals listed below. Including Protocols, User Interface (HMI) Operation, Installation, Configuration, Calibration, Maintenance, Parts, Safety and Approvals etc. including options.

Various other documents are available on the CD supplied with your shipment. Documents in hardcopy can also be ordered.

Copyrights, Notices and Trademarks

Copyright 2014 by Honeywell
Revision 1, March 2014

Trademarks

SFC, SmartLine, STT850 are U.S. registered trademarks of Honeywell Inc.

HART® is a trademark of the Hart Communication Foundation.

FOUNDATION™ is a trademark of the Fieldbus Foundation

References

The following list identifies all documents that may be sources of reference for material discussed in this publication.

Document Title	Document #
STT850 SmartLine Transmitter User's Manual	34-TT-25-03
STT850 SmartLine Transmitter HART/DE User Manual	34-TT-25-06
STT850 Foundation Fieldbus Manual	34-TT-25-07
STT850 Safety Manual	34-TT-25-05
STT850 Pocket Configuration Guide	34-TT-00-01
STT850 Specification	34-TT-03-14
MC Toolkit User Manual	34-ST-25-20

Table of Contents

Installation	3
Mounting the Transmitter	3
Bracket Mounting	3
Optional Mounting Bracket.....	4
Existing Mounting Bracket.....	4
Conduit Entry Plugs and Adapters	5
Wiring Connections and Power Up.....	6
Wiring Variations.....	8
Input Sensor Wiring.....	8
Digital Output Wiring.....	10
Explosion-Proof Conduit Seal	12
Set the Jumpers For HART/DE	13
Setting Failsafe Direction and Write Protect Jumpers	13
Write Protect Jumper on Foundation Fieldbus (FF).....	15
Configuration Guide	16

Tables

Table 1 – Basic Display Configuration.....	16
Table 2 – Advanced Display Configuration	23

Figures

Figure 1: Mounting Brackets	3
Figure 2: Pipe Mounting Bracket Secured to a Horizontal or Vertical Pipe.....	4
Figure 3: Electronic Housing Conduit Entries.....	5
Figure 4: HART Transmitter Operating Ranges	6
Figure 5: Transmitter 9-Screw Terminal Board and Grounding Screw	7
Figure 6: Thermocouple, mV and Volt Connections.....	8
Figure 7: RTD and Ohm Connections	9
Figure 8: Remote C/J and Mixed Sensors Connections.....	10
Figure 9: Digital Output Connections for mA Load	10
Figure 10: Digital Output Connections for PLC Counting Input	11
Figure 11: Jumper Location HART/DE.....	14
Figure 12: Jumper Settings	14
Figure 13: Fieldbus Write Protect.....	15

INSTALLATION

Evaluate the site selected for the Transmitter installation with respect to the process system design specifications and Honeywell's published performance characteristics for your particular model.

Temperature extremes can affect display quality. The display can become unreadable at temperature extremes; however, this is only a temporary condition. The display will again be readable when temperatures return to within operable limits.

MOUNTING THE TRANSMITTER

Transmitter models can be attached to a two-inch (50 millimeter) vertical or horizontal pipe using Honeywell's optional angle; alternately you can use your own bracket. Honeywell's optional wall mounting bracket is also shown below:

Figure 1 shows typical bracket-mounted installations.

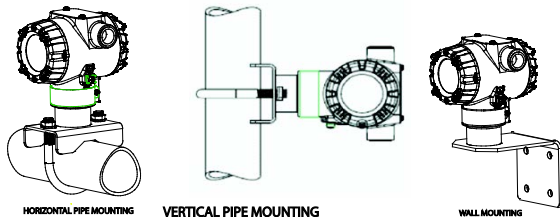

Figure 1: Mounting Brackets

Bracket Mounting

If you are using an optional bracket, start with Step 1.

1. Align the two mounting holes in the transmitter with the two slots in the mounting bracket and assemble the (2) M8 hex cap screws, (2) lockwashers and (2) flat washers provided. Rotate transmitter assembly to the desired position and torque the M8 hex cap screws to 27,0 Nm/20,0 Lb-ft maximum.
2. Pipe Mount Option: Refer to [Figure 2](#). Position the bracket on a 2-inch (50.8 mm) horizontal or vertical pipe, and install a "U" bolt around the pipe and through the holes in the bracket. Secure the bracket with the nuts, flat washers and lock washers provided.

3. Wall Mount Option: Position the bracket on the mounting surface at the desired location and secure the bracket to the mounting surface using the appropriate hardware (Wall mounting hardware requirements to be determined and supplied by the end user).

Optional mounting bracket, see [Figure 2](#)

Existing mounting bracket, see [Figure 2](#)

Optional Mounting Bracket

Position bracket on 2-inch (50.8 mm) or, and install "U" bolt around pipe and through holes in bracket. Secure with nuts and lock washers provided.

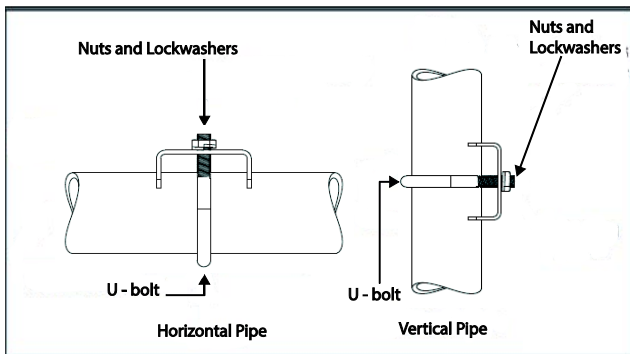

Figure 2: Pipe Mounting Bracket Secured to a Horizontal or Vertical Pipe

Existing Mounting Bracket

Align appropriate mounting holes in transmitter with holes in bracket and secure with bolts and washers provided.

CONDUIT ENTRY PLUGS AND ADAPTERS

Procedures

It is the User/Installer's responsibility to install the Transmitters in accordance with national and local code requirements. Conduit entry plugs and adapters shall be suitable for the environment, shall be certified for the hazardous location when required and acceptable to the authority having jurisdiction for the plant.

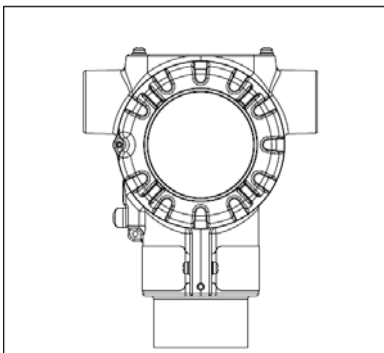

Figure 3: Electronic Housing Conduit Entries

Note. No plugs come installed in the housings. All housings come with temporary plastic dust protectors (red) installed and are not certified for use in any installation

WIRING CONNECTIONS AND POWER UP

Summary

The transmitter is designed to operate in a two-wire power/current loop with loop resistance and power supply voltage within the HART operating range shown in Figure 4.

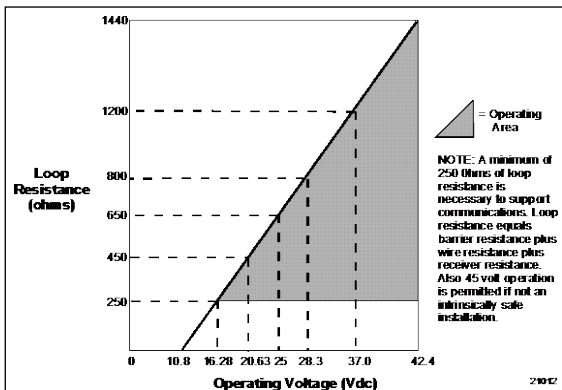

Figure 4: HART Transmitter Operating Ranges

For DE operation, add 3.0V to these values.

Loop wiring is connected to the Transmitter by simply attaching the positive (+) and negative (-) loop wires to the positive (+) and negative (-) terminals on the Transmitter terminal block in the Electronics Housing shown in Figure 5. Connect the Loop Power wiring shield to earth ground only at the power supply end.

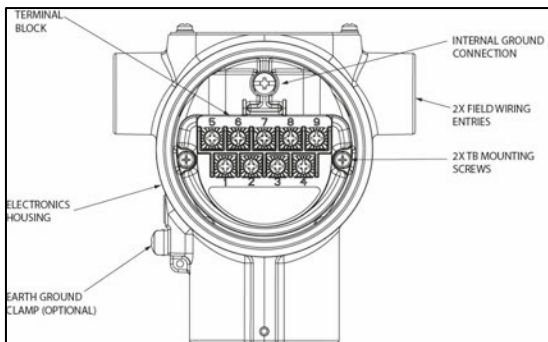

Figure 5: Transmitter 9-Screw Terminal Board and Grounding Screw

As shown in

[Figure 5](#), each Transmitter has an internal terminal to connect it to earth ground. Optionally, a ground terminal can be added to the outside of the Electronics Housing. Grounding the Transmitter for proper operation is required, as doing so tends to minimize the possible effects of noise on the output signal and affords protection against lightning and static discharge. An optional lightning terminal block can be installed in place of the non-lightning terminal block for Transmitters that will be installed in areas that are highly susceptible to lightning strikes. As noted above, the Loop Power wiring shield should only be connected to earth ground at the power supply end.



Wiring must comply with local codes, regulations and ordinances. Grounding may be required to meet various approval body certification, for example CE conformity. Refer to Appendix A of this document for details.

Note: Terminal #3 is for loop test and is not applicable for Fieldbus option.

The Transmitter is designed to operate in a two-wire power/current loop with loop resistance and power supply voltage within the operating range; see [Figure 4](#). With an optional remote meter, the voltage drop for this must be added to the basic power supply voltage requirements to determine the required Transmitter voltage and maximum loop resistance. Additional consideration is required when selecting intrinsic safety barriers to ensure that they will supply at least minimum Transmitter voltage, including the required 250 ohms of resistance (typically within the barriers) needed for digital communications.

Wiring Variations

The above procedures are used to connect power to a Transmitter. For loop wiring and external wiring, detailed drawings are provided for Transmitter installation in non-intrinsically safe areas and for intrinsically safe loops in hazardous area locations. This procedure shows the steps for connecting power to the transmitter.



Wiring must comply with local codes, regulations and ordinances. Grounding may be required to meet various approval body certification, for example CE conformity. Refer to the SmartLine Transmitter User's Manual 34-TT-25-03 (STT850) or 34-TT-25-06 (STT850) for details.

Input Sensor Wiring

Connect the input sensors as shown in Figures below:

Figure 6: Thermocouple, mV and Volt Connections

- To minimize common noise problems in the application, a strap/jumper should be wired between terminals 6 and 8.
- For differential T/C operation, a second strap/jumper should be wired between terminals 6 and 7. The output for differential operation is calculated as $T/C 1 - T/C 2$.

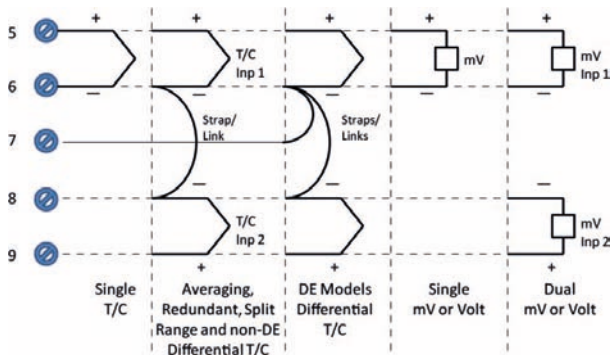

Figure 6: Thermocouple, mV and Volt Connections

Figure 7: RTD and Ohm Connections

- Resistance temperature detector (RTD) measurements use the 3 or 4 wire approach. The transmitter determines by itself if a 3 or 4 wire RTD is connected when powered up.
- Dual-input units wired for a 4-wire RTD will automatically disable Input 2.

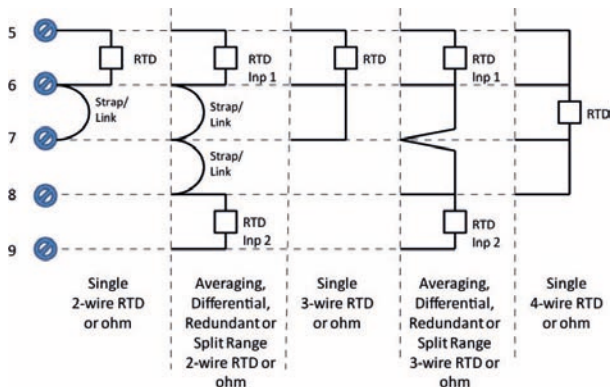

Figure 7: RTD and Ohm Connections

Figure 8: Remote C/J and Mixed Sensors Connections (Not available on DE Models)

- For Remote C/J compensation, the first input is a thermocouple type and the second input is a 3-wire PT100 ohm RTD
- The STT850 can have different sensor types on its inputs for split range or averaging applications

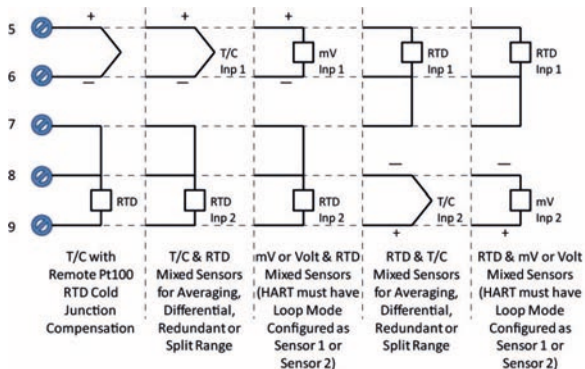

Figure 8: Remote C/J and Mixed Sensors Connections (Not available on DE Models)

Digital Output Wiring

The Digital Output is rated at a maximum load of 40 milliamps and 30 Volts. The Digital Output is mutually exclusive with the Second Sensor Input.

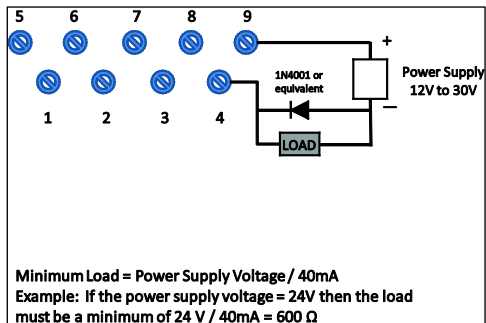

Figure 9: Digital Output Connections for mA Load

For best performance, it is recommended that:

- Digital Output wires should be in a separate shielded twisted pair cable, do not use the same cable as used for the Loop or the Sensor wires
- If using the same power supply to operate both the 4-20mA Loop and the Digital Output, then make the interconnections to the power supply terminals directly at the power supply

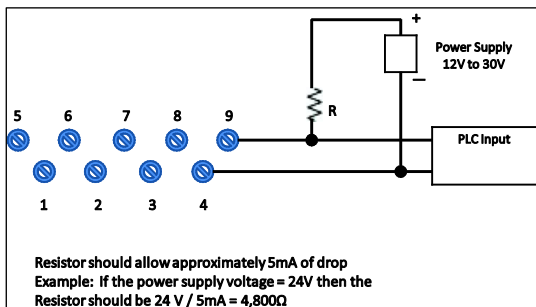

Figure 10: Digital Output Connections for PLC Counting Input

EXPLOSION-PROOF CONDUIT SEAL



When installed as explosion proof in a Division 1 Hazardous Location, keep covers tight while the Transmitter is energized. Disconnect power to the Transmitter in the non-hazardous area prior to removing end caps for service.

When installed as non-incendive equipment in a Division 2 hazardous location, disconnect power to the Transmitter in the non-hazardous area, or determine that the location is non-hazardous before disconnecting or connecting the Transmitter wires.

Transmitters installed as explosion proof in Class I, Division 1, Group A Hazardous (classified) locations in accordance with ANSI/NFPA 70, the US National Electrical Code, require a LISTED explosion proof seal to be installed in the conduit, within 18 inches (457.2 mm) of the Transmitter. Crouse-Hinds type EYS/EYD or EYSX/EYDX are examples of LISTED explosion proof seals that meet this requirement.

Transmitters installed as explosion proof in Class I, Division 1, Group B, C or D hazardous (classified) locations do not require that explosion proof seal be installed in the conduit.

Step	Action
1	See Figure 5 , above, for parts locations. Loosen the end cap lock using a 1.5 mm Allen wrench.
2	Remove the end cap cover from the terminal block end of the Electronics Housing
3	Feed loop power leads through one end of the conduit entrances on either side of the Electronics Housing. The Transmitter accepts up to 16 AWG wire.
4	Plug the unused conduit entrance.
5	Connect the positive loop power lead to the positive (+) terminal and the negative loop power lead to the negative (-) terminal. Note that the Transmitter is not polarity-sensitive.
6	Replace the end cap, and secure it in place.

SET THE JUMPERS FOR HART/DE

Setting Failsafe Direction and Write Protect Jumpers

The SmartLine Temperature Transmitter (DE or HART) provides two jumpers to set the desired failsafe action and Write Protect option. See

Figure 11

The top jumper on the electronics module sets the Failsafe direction. The default setting is up-scale failsafe.

Up Scale drives the loop to a value greater than 21mA while Down Scale drives the loop to a value less than 3.8mA.

You can change the failsafe direction by moving the Failsafe Jumper (top jumper) to the desired position (UP or DOWN).

If your transmitter is operating in DE mode, the upscale failsafe action will cause the transmitter to generate a "+ infinity" digital signal, while a downscale failsafe will cause the transmitter to generate a "- infinity" digital signal.

The bottom jumper sets the Write Protect. The default setting is OFF (Un-protected).

When set to the On (Protected) position, Changed configuration parameters cannot be written to the transmitter.

When set to the OFF (Un-protected) position, Changed configuration parameters can be written to the transmitter.

	<p>ATTENTION: <i>Electrostatic Discharge (ESD) hazards. Observe precautions for handling electrostatic sensitive devices</i></p>
Step	Action
1	Turn OFF Transmitter power.
2	Loosen the end-cap lock, and unscrew the end cap from the Electronics side of the Transmitter housing.
3	<p>If applicable, carefully depress the tabs on the sides of the Display Module and pull it off.</p> <p>If necessary, move the interface connector from the Communication Module to the display module to provide the preferred orientation of the display module in the window.</p>
4	<p>Set the Failsafe Jumper (top jumper) to the desired action (UP or DOWN). And the Write Protect jumper (Bottom jumper) to the desired behavior (Protected or Unprotected) See</p> <p>Figure 12 for jumper positioning.</p>
5	Screw on the end cap and tighten the end-cap lock.
6	Turn ON Transmitter power.

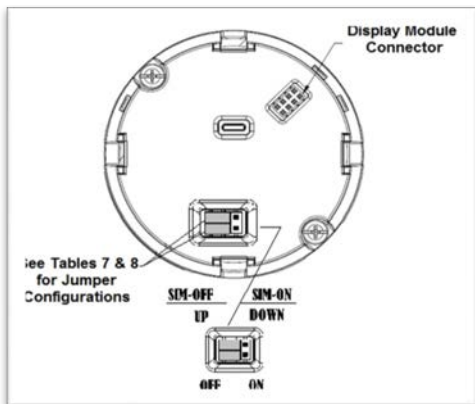

Figure 11: Jumper Location HART/DE





Jumper Settings	Description
	<i>Failsafe = UP (High)</i> <i>Write Protect = OFF (Not Protected)</i>
	<i>Failsafe = DOWN (Low)</i> <i>Write Protect = OFF (Not Protected)</i>
	<i>Failsafe = UP (High)</i> <i>Write Protect = ON (Protected)</i>
	<i>Failsafe = DOWN (Low)</i> <i>Write Protect = ON (Protected)</i>

Figure 12: Jumper Settings

WRITE PROTECT JUMPER ON FOUNDATION FIELDBUS (FF)

On Foundation Fieldbus transmitters there is no Failsafe jumper selection but there is a Write Protect jumper.

The bottom jumper sets the Write Protect. The default setting is OFF (Un-protected).

When set to the On (Protected) position, Changed configuration parameters cannot be written to the transmitter.

When set to the OFF (Un-protected) position, Changed configuration parameters can be written to the transmitter.



	ATTENTION: Electrostatic Discharge (ESD) hazards. Observe precautions for handling electrostatic sensitive devices.
	WARNING! PERSONAL INJURY: Risk of electrical shock. Disconnect power before proceeding. HAZARDOUS LIVE voltages greater than 30 Vrms, 42.4 Vpeak, or 60 VDC may be accessible. Failure to comply with these instructions could result in death or serious injury.
Step	Action
1	Turn OFF Transmitter power.
2	Loosen the end-cap lock, and unscrew the end cap from the Electronics side of the Transmitter housing.
3	If applicable, carefully depress the tabs on the sides of the Display Module and pull it off.
4	Set the Write Protect jumper (Bottom jumper) to the desired behavior (Protected or Unprotected). See Figure 13 for jumper positioning.
5	Screw on the end cap and tighten the end-cap lock.
6	Turn ON Transmitter power.



Image	Description
	Fieldbus SIM Mode = OFF Write Protect = OFF (Not Protected)
	Fieldbus SIM Mode = OFF Write Protect = ON (Protected)
	Fieldbus SIM Mode = ON Write Protect = OFF (Not Protected)

Figure 13: Fieldbus Write Protect

CONFIGURATION GUIDE

Table 1 shows the transmitter Basic Display Configuration. Table 2 shows the Advanced Display Configuration. Use these tables to configure the transmitter.

Table 1 – Basic Display Configuration

LCD Contrast	»»»»»	Adjust the LCD contrast level. Range from » (1) to »»»»»»»» (9) Default: »»»»»»» (7)	Press \downarrow to enter menu selection \uparrow and \downarrow to select level. \downarrow to enter
Screen Decimals	None	Select the PV decimal resolution to be shown on selected screen from list.	
	X.X		
	X.XX		
	X.XXX		
Screen Units	°C	Choose appropriate engineering units from list	
	°F		
	°R		
	°K		
Range/Cal Units	°C, °F, °R, °K Select the ranging and calibration temperature units		
Select Input	Select Input number to configure, referred to as "n" in subsequent menu items		
Sensor n Type	mV, TC, RTD, Ohm		
Sensor n ID	Sensor ID for Input n within to selected Sensor Type		
RTD n Type	2-Wire, 3-Wire, 4-Wire		
RTD n Lead Wire	Resistance of Input in RTD lead wires		
Sensor n Bias	Bias value which is applied to the Input in measured value		
Sens n Cal Lo Pt	Calibration low point for Sensor n		

Sens n Cal Hi Pt	Calibration high point for Sensor n	
Reset Cal n Corr	Executing this selection resets the Sensor 1 calibrations back to Factory values	
Screen Rotate	Enabled Disabled	Select to enable or disable the automatic rotation of Screens
Select Screen	Select Screen to configure.	
Screen	Enabled/Disabled	
Screen PV	Loop PV Sensor 1 Sensor 2 CJ Temperature Sensor 1 Resistance Sensor 2 Resistance Loop Output Percent Output	Select the Process Variable (PV) that will be shown on the screen. Sensor Resistance is only available for RTDs and will read 0 for thermocouples
Screen Decimal	None X.X X.XX X.XXX	Select the decimal resolution for the PV
Do Sens n Cal Lo	Confirm	Executing this selection corrects the Cal Low Point based on the input measurement
Do Sens n Cal Hi	Confirm	Executing this selection corrects the Cal High Point based on the input measurement
Reset Sens n Cal	Confirm	Executing this selection Resets the LRV, and URV Corrects back to Factory values

DAC Zero Trim Note: Loop must be removed from Automatic Control	DAC Zero Trim	This selection allows the loop zero output 4mA value to be trimmed. Note: You must connect a current meter to the transmitter to monitor the loop output.	Press \downarrow to enter menu selection \uparrow and \downarrow to select number. \downarrow to enter and shift to the next digit to the right
DAC Span Trim Note: Loop must be removed from Automatic Control	DAC Span Trim	This selection allows the loop span output 20mA value to be trimmed. Note: You must connect a current meter to the transmitter to monitor the loop output.	
Loop Test Note: Loop must be removed from Automatic Control	Loop Test 12.000	This selection allows the user to force the DAC output to any value between 3.8 and 20.8 mA. Note: This selection will put the DAC into Fixed Output Mode, as indicated by the flashing output value. Navigation away from this menu item will return the loop to Normal (Automatic) Mode.	
Loop Ctrl Mode	Average, Difference, Sensor 1, Sensor 2, Split-Range, Redundant	Mode of Loop control	
Loop Ctrl Src	Input sensor currently controlling the Loop		
Excess Delta	Enable, Disable	Enable or disable Critical Diagnostic when Sensor Delta (difference between Sensor 1 and Sensor 2) exceeds Delta Limit. A Non-Critical Diagnostic occurs if Disabled	

Delta Limit	Value that will produce a Diagnostic if exceeded by Sensor Delta.		
Bumpless Damping	Damping value for the transition of Loop Control between Sensors when Loop Ctrl Mode is Split-Range or Redundant		
Hysteresis	Hysteresis value relative to the MRV for the transition of Loop Control between Sensors when Loop Ctrl Mode is Split-Range		
Break Detect	Enable, Disable	Enable or disable detection of Input wire break	
Match PVs	Enable, Disable	For Redundant Loop Control Mode. When enabled, adds a constant bias value to the Sensor 2 measured value to equate it to the Sensor 1 measured value at the moment selected.	
Latching	When enabled, causes all Critical Diagnostics to latch to the Fault state, and will not be released until a power cycle occurs.		
CJ Comp Src	Internal, External, Fixed	Determines the source of the Cold Junction compensation for thermocouple Sensor types.	

Fixed CJ Value	When CJ Comp Src is Fixed, specifies the Cold Junction temperature value for thermocouple Sensor types.		
HART Device ID	Unique for each device Read Only		
HART PV Units	Units of transmitted PV		
HART PV 2 Units	Units of transmitted PV 2		
HART SV Units	Units of transmitted SV		
HART Date	<Return>		
	Year	# # # #	Enter the current year
	Month	January through December	Select the current month
	Day	# #	Enter the day of the month
	Write Date	Press ENTER to write the HART Date to the transmitter	

	Install Date	DD MM YYYY. This selection allows the user to enter the date a transmitter is installed. The Install Date is entered in sequence of Day, Month, and Year, followed by the new date and the prompt Write Date to confirm the entry. CAUTION: The Install Date can only be written once in the life of the Transmitter. You cannot erase or overwrite the Install Date once it has been written. Press enter menu selection ↑ and ↓ to select number ↵ to enter and shift to next digit to the right.	
LRV URV	#. ## #. ##	The limits are: the Lower Range Limit (LRL) and the Upper Range Limit (URL) of the selected Sensor 1 ID	Press ↵ to enter menu selection ↑ and ↓ to select number. ↵ to enter and shift to the next digit to the right
MRV	###.##	Limits are the minimum URL and maximum LRL of the selected Sensor 1 and Sensor 2 IDs. Determines the point of transition of Loop Control between Sensor 1 and Sensor 2 for Split-Range Loop Control Mode.	
Damping	#. ##	Selection applies digital filtering to suppress noise effects on the PV. The limits for this value are 0.0 to 32.0 seconds	
NAMUR Output	Enabled Disabled	Disabling sets the loop output and burnout levels to the Honeywell levels	Press ↵ to enter menu selection ↑ and ↓ to select from list ↵ to enter

Tag ID	□□□□□□□□	Enter Tag ID name up to 8 characters long. □ = any Alphanumeric value	Press ↓ to enter menu selection ↑ and ↓ to select Alphanumeric ↓ to enter and shift to next character to the right.
Install Date	DD MM YYYY	This selection allows the user to enter the date a transmitter is installed. The Install Date is entered in sequence of Day, Month, and Year, followed by the new date and the prompt Write Date to confirm the entry. CAUTION: The Install Date can only be written once in the life of the Transmitter. You cannot erase or overwrite the Install Date once it has been written.	Press ↓ to enter menu selection ↑ and ↓ to select number ↓ to enter and shift to next digit to the right. Read Only after entered
Firmware	Display Electronics Sensor	Menu item shows the current Firmware versions of the Display, Electronics Module and the Sensor Module	Read Only Parameter
Protocol	HART DE	Menu item shows the communications protocol	
Model Key		Identifies the type and range of the transmitter	Read Only Parameter
<Exit Menu>			

Table 2 – Advanced Display Configuration

Level 1	Level 2	Level 3
<Exit>	n/a	n/a
Diagnostics	Critical Non-Critical	For details go to the Diagnostics Menu table
Display Setup	LCD Contrast Common Setup Screen 1 Screen 2 ... Screen 8	For details go to the Display Setup Menu table. Note that the Advanced Display supports the configuration of up to 8 different screens.
Calibration	Cal Points Set Time Stamp DAC Trim Loop Test	For details go to the Calibration Menu table.
Transmtr Setup	Device Setup HART Setup HART Date Sensor Setup Enter LRV Enter URV Enter MRV Set LRV Enter MRV Set URV Dev Install Date S1 Install Date S2 Install Date	For details go to the Transmitter Setup Menu table.
Information	Display Comm Module Sensor Module	For details go to the Information Menu table.

Sales and Service

For application assistance, current specifications, pricing, or name of the nearest Authorized Distributor, contact one of the offices below.

ASIA PACIFIC (TAC)

Australia Honeywell Limited, Phone: +(61) 7-3846 1255, FAX: +(61) 7-3840 6481

Toll Free 1300-36-39-36, Toll Free Fax: 1300-36-04-70

China – PRC – Shanghai, Honeywell China Inc. Phone: (86-21) 5257-4568,

Fax: (86-21) 6237-2826

Singapore, Honeywell Pte Ltd. Phone: +(65) 6580 3278. Fax: +(65) 6445-3033

South Korea, Honeywell Korea Co Ltd. Phone:+(822)799 6114. Fax:+(822) 792 9015

EMEA, Phone: + 80012026455 or +44 (0)1202645583. FAX: +44 (0) 1344 655554

Email: (Sales) sc-cp-apps-salespa62@honeywell.com

or (TAC) hfs-tac-support@honeywell.com

NORTH AMERICA, Honeywell Process Solutions, Phone: 1-800-423-9883,

Or 1-800-343-0228. Email: (Sales) ask-ssc@honeywell.com

or (TAC) hfs-tac-support@honeywell.com

WARRANTY/REMEDY

Honeywell warrants goods of its manufacture as being free of defective materials and faulty workmanship. Contact your local sales office for warranty information.

If warranted goods are returned to Honeywell during the period of coverage, Honeywell will repair or replace without charge those items it finds defective. The foregoing is Buyer's sole remedy and is **in lieu of all other warranties, expressed or implied, including those of merchantability and fitness for a particular purpose.**

Specifications may change without notice. The information we supply is believed to be accurate and reliable as of this printing. However, we assume no responsibility for its use.

While we provide application assistance personally, through our literature and the Honeywell web site, it is up to the customer to determine the suitability of the product in the application.

**Honeywell Process Solutions**

1250 W Sam Houston Pkwy S
Houston, TX 77042

www.honeywellprocess.com

34-TT-25-04 Rev.1

March 2014

©2014 Honeywell International Inc.