

Technical Information

STG700 SmartLine Gauge Pressure Specification 34-ST-03-102



Introduction

Part of the SmartLine® family of products, the STG700 and STG70L are suitable for monitoring, control and data acquisition. STG70X products feature piezoresistive sensor technology combining pressure sensing with on chip temperature compensation capabilities providing high accuracy, stability and performance over a wide range of application pressures and temperatures. The SmartLine family is also fully tested and compliant with Experia[®] PKS providing the highest level of compatibility assurance and integration capabilities. SmartLine easily meets the most demanding application needs for pressure measurement applications.

Best in Class Features:

- Accuracy up to 0.065 % of calibrated span
- Stability up to 0.02% of URL per year for five years
- Automatic temperature compensation
- Rangeability up to 100:1
- Response times as fast as 100ms
- Alphanumeric display capabilities
- External zero, span, & configuration capability
- Polarity insensitive electrical connections
- On-board diagnostic capabilities
- Integral Dual Seal design for safety based on ANSI/NFPA 70-202 and ANSI/ISA 12.27.0
- Full compliance to SIL 2/3 requirements as a standard.
- Modular design characteristics

Span & Range Limits:

Model	URL/Max Span psi (bar)	LRL psi (bar)	Min Span	Turn down
STG740/STG74L	500 (35)	-14.7 (-1.0)	5 (.35)	100:1
STG770/STG77L	3000 (210)	-14.7 (-1.0)	30 (2.1)	100:1
STG78L	6000 (420)	-14.7 (-1.0)	60 (4.2)	100:1
STG79L	10000 (690)	-14.7 (-1.0)	100 (6.9)	100:1



Figure 1 – STG700 Gauge Pressure Transmitters feature field-proven piezoresistive sensor technology

Communications/Output Options:

- Honeywell Digitally Enhanced (DE)
- HART[®] (version 7.0)
- FOUNDATION™ Fieldbus

All transmitters are available with the above listed communications protocols.

Description

The SmartLine family pressure transmitters are designed around a high performance piezo-resistive sensor. This one sensor actually integrates multiple sensors linking process pressure measurement with on-board static pressure (DP Models) and temperature compensation measurements. This level of performance allows the ST 700 to replace most competitive transmitters available today.

Indication/Display Option

The ST 700 modular design accommodates a basic alphanumeric LCD display.

Basic Alphanumeric LCD Display Features

- Modular (may be added or removed in the field)
- 0, 90,180, & 270 degree position adjustments
- Pa, KPa, MPa, KGcm2, Torr, ATM, i4H₂O, mH₂O, bar, mbar, inH₂O, inHG, FTH₂O, mmH₂O, mm HG, & psi measurement units
- 2 Lines 16 Characters (4.13H x 1.83W mm)
- Square root output indication

Diagnostics

SmartLine transmitters all offer digitally accessible diagnostics which aid in providing advanced warning of possible failure events minimizing unplanned shutdowns, providing **lower overall operational costs**

Configuration Tools

Integral Three Button Configuration Option

Suitable for all electrical and environmental requirements, SmartLine offers the ability to configure the transmitter and display via three externally accessible buttons when a display option is selected. Zero/span capabilities are also optionally available via these buttons with or without selection of the display option.

Hand Held Configuration

SmartLine transmitters feature two-way communication and configuration capability between the operator and the transmitter. This is accomplished via Honeywell's field-rated Multiple Communication Configurator (MCT202).

The MCT202 is capable of field configuring DE and HART Devices and can also be ordered for use in intrinsically safe environments. All Honeywell transmitters are designed and tested for compliance with the offered communication protocols and are designed to operate with any properly validated hand held configuration device.

Personal Computer Configuration

Honeywell's SCT 3000 Configuration Toolkit provides an easy way to configure Digitally Enhanced (DE) instruments using a personal computer as the configuration interface. Field Device Manager (FDM) Software and FDM Express are also available for managing HART & Fieldbus device configurations.

System Integration

- SmartLine communications protocols all meet the most current published standards for HART/DE/Fieldbus.
- Integration with Honeywell's Experion PKS offers the following unique advantages.
 - Tamper reporting
 - FDM Plant Area Views with Health summaries
 - All ST 700 units are Experion tested to provide the highest level of compatibility assurance

Modular Design

To help contain maintenance & inventory costs, all ST 700 transmitters are modular in design supporting the user's ability to replace meter bodies, add indicators or change electronic modules without affecting overall performance or approval body certifications. Each meter body is uniquely characterized to provide in-tolerance performance over a wide range of application variations in temperature and pressure and due to the Honeywell advanced interface, electronic modules may be swapped with any electronics module without losing in-tolerance performance characteristics.

Modular Features

- Meter body replacement
- Exchange/replace electronics/comms modules*
- Add or remove integral indicator*
- Add or remove lightning protection (terminal connection)*

* Field replaceable in all electrical environments (including IS) except flameproof without violating agency approvals.

With no performance effects, Honeywell's unique modularity results in **lower inventory needs and lower overall operating costs.**

Performance Specifications¹

Reference Accuracy²:(conformance to +/-3 Sigma)

	Model	URL	LRL	Min Span	Maximum Turndown Ratio	Stability (% URL/Year for five years)	Reference Accuracy (% Span)
Standard Accuracy	STG740	500 psi (35 bar)	-14.7 psi (-1.0 bar)	5 psi (.35 bar)	100:1	0.02%	0.0650%
	STG74L	500 psi (35 bar)	-14.7 psi (-1.0 bar)	5 psi (.35 bar)			
	STG770	3000 psi (210 bar)	-14.7 psi (-1.0 bar)	30 psi (2.1 bar)			
	STG77L	3000 psi (210 bar)	-14.7 psi (-1.0 bar)	30 psi (2.1 bar)			
	STG78L	6000 psi (420 bar)	-14.7 psi (-1.0 bar)	60 psi (4.2 bar)			
	STG79L	10000 psi (690 bar)	-14.7 psi (-1.0 bar)	100 psi (6.9 bar)			

Zero and span may be set anywhere within the listed (URL/LRL) range limits

Accuracy at Specified Span and Temperature: (conformance to +/-3 Sigma)

		Accuracy ¹ (% of Span)				Temperature Effect (% Span/50°F)		
	Model	URL	For Turndowns Greater Than	A	B	C psi (bar)	D	E
Standard Accuracy	STG740	500 psi (35 bar)	25:1	0.025	0.04	20 (1.4)	0.050	0.007
	STG74L	500 psi (35 bar)	25:1			30 (2.1)		0.010
	STG770	3000 psi (210 bar)	10:1			300 (20.7)		0.010
	STG77L	3000 psi (210 bar)	10:1			350 (24.2)		0.015
	STG78L	6000 psi (420 bar)	12:1			500 (34.4)		0.050
	STG79L	10000 psi (690 bar)	10:1			1000 (69)		0.050
Turn Down Effect						Temp Effect		
$\pm \left[A + B \left(\frac{C}{\text{Span}} \right) \right]$ % Span						$\pm \left[D + E \left(\frac{\text{URL}}{\text{Span}} \right) \right]$ % Span per 28°C (50°F)		

Total Performance (% of Span):

Total Performance Calculation: $= \pm \sqrt{(\text{Accuracy})^2 + (\text{Temperature Effect})^2}$

Total Performance Examples (for comparison): @ 5:1 Turndown, +/-50 °F (28°C) shift

STG740 @ 100 psi: 0.107% of span

STG74L @ 100 psi: 0.119% of span

STG770 @ 600 psi: 0.119 % of span

STG77L @ 600 psi: 0.141% of span

STG78L @ 1200 psi: 0.307% of span

STG79L 2000 psi: 0.307% of span

Typical Calibration Frequency:

Calibration verification is recommended every two (2) years

Notes:

1. Terminal Based Accuracy - Includes combined effects of linearity, hysteresis, and repeatability. Analog output adds 0.005% of span.
2. For zero based spans and reference conditions of: 25 °C (77°F), 10 to 55% RH, and 316 Stainless Steel barrier diaphragm.

Operating Conditions – All Models

Parameter	Reference Condition		Rated Condition		Operative Limits		Transportation and Storage	
	°C	°F	°C	°F	°C	°F	°C	°F
Ambient Temperature ¹	25±1	77±2	-40 to 85	-40 to 185	-40 to 85	-40 to 185	-55 to 120	-67 to 248
Meter Body Temperature ²	25±1	77±2	-40 to 110	-40 to 230	-40 to 125	-40 to 257	-55 to 120	-67 to 248
Humidity %RH	10 to 55		0 to 100		0 to 100		0 to 100	
Vac. Region – Min. Pressure mmHg absolute inH ₂ O absolute	Atmospheric Atmospheric		25 13		2 (short term) ³ 1 (short term) ³			
Supply Voltage Load Resistance	10.8 to 42.4 Vdc at terminals 0 to 1,440 ohms (as shown in Figure 2)							
Maximum Allowable Working Pressure (MAWP) ^{4,5} <small>(ST700 products are rated to Maximum Allowable Working Pressure. MAWP depends on Approval Agency and transmitter materials of construction.)</small>	STG740: 500 psi (35 bar) STG770: 3000 psi (210 bar)		STG74L: 500 psi (35 bar) STG77L: 3000 psi (210 bar) STG78L: 6000 psi (420 bar) STG79L: 10000 psi (690 bar)					

¹ LCD Display operating temperature -20°C to +70°C Storage temperature -30°C to 80°C.

² For CTFE fill fluid, the rating is -15 to 110°C (5 to 230°F)

³ Short term equals 2 hours at 70°C (158°F)

⁴ Units can withstand overpressure of 1.5 x MAWP without damage

⁵ Consult factory for MAWP of ST 700 transmitters with CRN approval

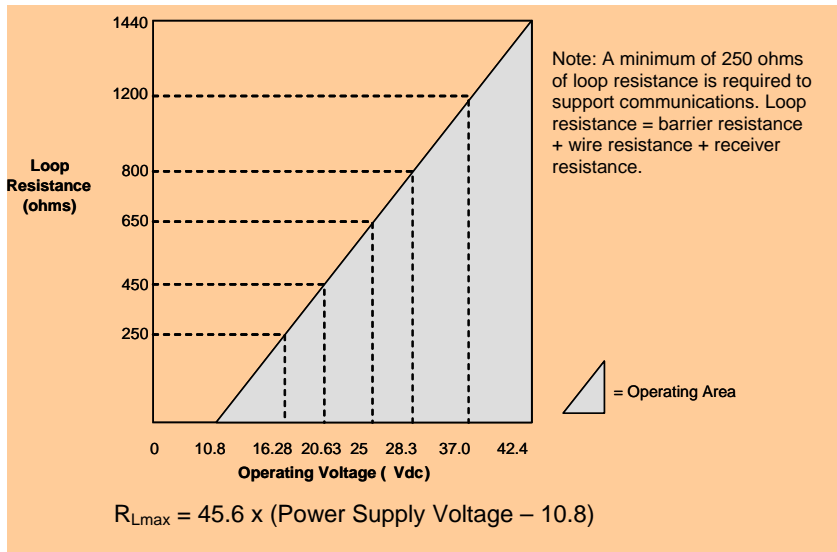

Figure 2 - Supply voltage and loop resistance chart & calculations

Performance Under Rated Conditions – All Models

Parameter	Description									
Analog Output Digital Communications:	Two-wire, 4 to 20 mA (HART & DE Transmitters only) Honeywell DE, HART 7 protocol or FOUNDATION Fieldbus ITK 6.0.1 compliant All transmitters, irrespective of protocol have polarity insensitive connection.									
Output Failure Modes (configurable)	<table style="width: 100%; border: none;"> <tr> <td style="width: 30%;"></td> <td style="text-align: center;">Honeywell Standard:</td> <td style="text-align: center;">NAMUR NE 43 Compliance:</td> </tr> <tr> <td>Normal Limits:</td> <td style="text-align: center;">3.8 – 20.8 mA</td> <td style="text-align: center;">3.8 – 20.5 mA</td> </tr> <tr> <td>Failure Mode:</td> <td style="text-align: center;">≤ 3.6 mA and ≥ 21.0 mA</td> <td style="text-align: center;">≤ 3.6 mA and ≥ 21.0 mA</td> </tr> </table>		Honeywell Standard:	NAMUR NE 43 Compliance:	Normal Limits:	3.8 – 20.8 mA	3.8 – 20.5 mA	Failure Mode:	≤ 3.6 mA and ≥ 21.0 mA	≤ 3.6 mA and ≥ 21.0 mA
	Honeywell Standard:	NAMUR NE 43 Compliance:								
Normal Limits:	3.8 – 20.8 mA	3.8 – 20.5 mA								
Failure Mode:	≤ 3.6 mA and ≥ 21.0 mA	≤ 3.6 mA and ≥ 21.0 mA								
Supply Voltage Effect	0.005% span per volt.									
Transmitter Turn on Time (includes power up & test algorithms)	HART or DE: 2.5 sec Foundation Fieldbus: Host dependant									
Response Time (delay + time constant)	<table style="width: 100%; border: none;"> <tr> <td style="text-align: center;"><u>DE/HART Protocol</u></td> <td style="text-align: center;"><u>FOUNDATION Fieldbus</u></td> </tr> <tr> <td style="text-align: center;">100ms</td> <td style="text-align: center;">150ms (Host Dependant)</td> </tr> </table>	<u>DE/HART Protocol</u>	<u>FOUNDATION Fieldbus</u>	100ms	150ms (Host Dependant)					
<u>DE/HART Protocol</u>	<u>FOUNDATION Fieldbus</u>									
100ms	150ms (Host Dependant)									
Damping Time Constant	HART: Adjustable from 0 to 32 seconds in 0.1 increments. Default Value: 0.5 seconds DE: Discrete values 0, 0.16, 0.32, 0.48, 1, 2, 4, 8, 16, 32 seconds. Default Value: 0.48 seconds									
Vibration Effect:	Less than +/- 0.1% of URL w/o damping Per IEC60770-1 field or pipeline, high vibration level (10-2000Hz: 0.21 displacement/3g max acceleration)									
Electromagnetic Compatibility	IEC 61326-3-1									
Lightning Protection Option	Leakage Current: 10uA max @ 42.4VDC 93C Impulse rating: 8/20uS 5000A (>10 strikes) 10000A (1 strike min.) 10/1000uS 200A (> 300 strikes)									

Materials Specifications (see model selection guide for availability/restrictions with various models)

Parameter	Description
Barrier Diaphragms Material	STG700: 316L SS, Hastelloy [®] C-276 ² , Monel [®] 400 ³ , Tantalum STG70L: 316L SS, Hastelloy C-276
Process Head Material	STG700: Carbon Steel (Zinc Plated) ⁵ , 316 SS ⁴ , Hastelloy [®] C-276 ⁶ , Monel [®] 400 ⁷ STG70L: 316 SS ⁴
Vent/Drain Valves & Plugs ¹	STG700: 316 SS ⁴ , Hastelloy C-276 ² , Monel 400 ⁷ STG70L: N/A
Head Gaskets	STG700: Glass-filled PTFE standard. Viton [®] and graphite are optional. STG70L: N/A
Meter Body Bolting	STG700: Carbon Steel (Zinc plated) standard. Options include 316 SS, NACE A286 SS bolts and nuts or NACE A286 SS bolts and 304 SS nuts STG70L: N/A
Mounting Bracket	Carbon Steel (Zinc-plated) or 304 Stainless Steel angle bracket or Carbon Steel flat bracket available .with 2" pipe bracket. See Figures 4 & 5
Fill Fluid	Silicone DC [®] 200 oil or CTFE (Chlorotrifluoroethylene).
Electronic Housing	Pure Polyester Powder Coated Low Copper (<0.6%)-Aluminum. Meets NEMA 4X, IP66, IP67 and NEMA 7 (explosion proof). All stainless steel housing is optional.
Process Connections	STG700: ½ -inch NPT(female), DIN 19213 (standard) STG70L: ½ -inch NPT(female), ½ -inch NPT male, 9/16 Aminco, DIN19213 (except STG79L)
Wiring	Accepts up to 16 AWG (1.5 mm diameter).
Dimensions	See Figures 4 & 5
Net Weight	STG700: 8.3 pounds (3.8 Kg). STG70L: 3.6 pounds (1.6 Kg) with Aluminum Housing

¹ Vent/Drains are sealed with Teflon[®]² Hastelloy[®] C-276 or UNS N10276³ Monel[®] 400 or UNS N04400⁴ Supplied as 316 SS or as Grade CF8M, the casting equivalent of 316 SS.⁵ Carbon Steel heads are zinc-plated and not recommended for water service due to hydrogen migration. For that service, use 316 stainless steel wetted Process Heads.⁶ Hastelloy[®] C-276 or UNS N10276. Supplied as indicated or as Grade CW12MW, the casting equivalent of Hastelloy[®] C-276⁷ Monel[®] 400 or UNS N04400. Supplied as indicated or as Grade M30C, the casting equivalent of Monel[®] 400

Communications Protocols & Diagnostics

HART Protocol

Version:

HART 7

Power Supply

Voltage: 10.8 to 42.4Vdc at terminals

Load: Maximum 1440 ohms See figure 2

Minimum Load: 0 ohms. (For handheld communications a minimum load of 250 ohms is required)

Foundation Fieldbus (FF)

Power Supply Requirements

Voltage: 9.0 to 32.0Vdc at terminals

Steady State Current: 17.6mAdc

Software Download Current: 27.4mAdc

Available Function Blocks

Block Type	Qty	Execution Time
Resource	1	n/a
Transducer	1	n/a
Diagnostic	1	n/a
Analog Input	1*	30 ms
PID w/Autotune	1	45 ms
Integrator	1	30 ms
Signal Char (SC)	1	30 ms
LCD Display	1	n/a
Flow Block	1	30 ms
Input Selector	1	30 ms
Arithmetic	1	30 ms

* All block may have two (2) additional instantiations.

All available function blocks adhere to FOUNDATION Fieldbus standards. PID blocks support ideal & robust PID algorithms with full implementation of Auto-tuning.

Link Active Scheduler

Transmitters can perform as a backup Link Active Scheduler and take over when the host is disconnected.

Acting as a LAS, the device ensures scheduled data transfers typically used for the regular, cyclic transfer of control loop data between devices on the Fieldbus.

Number of Devices/Segment

Entity IS model: 6 devices/segment

Schedule Entries

18 maximum schedule entries

Number of VCR's: 24 max

Compliance Testing: Tested according to ITK 6.0.1

Software Download

Utilizes Class-3 of the Common Software Download procedure as per FF-883 which allows the field devices of any manufacturer to receive software upgrades from any host.

Honeywell Digitally Enhanced (DE)

DE is a Honeywell proprietary protocol which provides digital communications between Honeywell DE enabled field devices and Hosts.

Power Supply

Voltage: 10.8 to 42.4Vdc at terminals

Load: Maximum 1440 ohms See figure 2

Standard Diagnostics

ST 700 top level diagnostics are reported as either critical or non-critical and readable via the DD/DTM tools or integral display as shown

Critical Diagnostics

HART DD/DTM tools	Basic Display
Electronic Module DAC Failure	Electronics Module fault
Meter Body NVM Corrupt	Meterbody fault
Config Data Corrupt	Electronics Module fault
Electronic Module Diag Failure	Electronics Module fault
Meter Body Critical Failure	Meterbody fault
Sensor Comm Timeout	Meterbody Comm fault

Non-Critical Diagnostics

HART DD/DTM tools
Display Failure
Electronic Module Comm Failure
Meter Body Excess Correct
Sensor Over Temperature
Fixed Current Mode
PV Out of Range
No Factory Calibration
No DAC Compensation
LRV Set Error – Zero Config Button
URV Set Error – Span Config Button
AO Out of Range
Loop Current Noise
Meter Body Unreliable Comm
Tamper Alarm
No DAC Calibration
Sensor Supply Voltage Low

Other Certification Options

Materials

- NACE MRO175, MRO103, ISO15156

Approval Certifications:

AGENCY	TYPE OF PROTECTION	COMM. OPTION	FIELD PARAMETERS	AMBIENT TEMP (Ta)
FM Approvals™	Explosionproof: Class I, Division 1, Groups A, B, C, D; Dust Ignition Proof: Class II, III, Division 1, Groups E, F, G; T4 Class I, Zone 1/2, AEx d IIC T4 Class II, Zone 21, AEx tb IIIC T 95°C IP 66	All	Note 1	-50 °C to 85°C
	Intrinsically Safe: Class I, II, III, Division 1, Groups A, B, C, D, E, F, G; T4 Class I, Zone 0, AEx ia IIC T4 Class II, Zone 20, AEx ta IIIC T 95°C IP 66	4-20 mA / DE/ HART	Note 2a	-50 °C to 70°C
		Foundation Fieldbus	Note 2b	-50 °C to 70°C
	Nonincendive: Class I, Division 2, Groups A, B, C, D locations, Class I, Zone 2, AEx nA IIC T4 Class I, Zone 2, AEx ic IIC T4 Class II, Zone 22, AEx tc IIIC T 95°C IP 66	4-20 mA / DE/ HART	Note 1	-50 °C to 85°C
		Foundation Fieldbus	Note 1	-50 °C to 85°C
	Enclosure: Type 4X/ IP66/ IP67	All	All	-
Canadian Standards Association (CSA)	Explosion Proof: Class I, Division 1, Groups A, B, C, D; Dust Ignition Proof: Class II, III, Division 1, Groups E, F, G; T4 Ex d IIC T4 Ex tb IIIC T 95°C IP 66	All	Note 1	-50 °C to 85°C
	Intrinsically Safe: Class I, II, III, Division 1, Groups A, B, C, D, E, F, G; T4 Ex nA IIC T4 Ex tc IIIC T 95°C IP 66	4-20 mA / DE/ HART	Note 2a	-50 °C to 70°C
		Foundation Fieldbus	Note 2b	-50 °C to 70°C
	Nonincendive: Class I, Division 2, Groups A, B, C, D; T4 Ex nA IIC T4 Ex tc IIIC T 95°C IP 66	4-20 mA / DE/ HART	Note 1	-50 °C to 85°C
		Foundation Fieldbus	Note 1	-50 °C to 85°C
	Enclosure: Type 4X/ IP66/ IP67	All	All	-
	Canadian Registration Number (CRN):	All models except STG79L, STG770 and have been registered in all provinces and territories in Canada and are marked CRN: 0F8914.5C.		

Approval Certifications: (Continued)

ATEX	Flameproof: II 1/2 G Ex d IIC T4 II 2 D Ex tb IIIC T 85°C IP 66	All	Note 1	-50 °C to 85°C
	Intrinsically Safe: II 1 G Ex ia IIC T4 II 1 D Ex ta IIIC T 85°C IP 66	4-20 mA / DE/ HART	Note 2a	-50 °C to 70°C
		Foundation Fieldbus	Note 2b	-50 °C to 70°C
	Nonincendive: II 3 G Ex nA IIC T4 II 3 D Ex tc IIIC T 85°C IP 66	4-20 mA / DE/ HART	Note 1	-50 °C to 85°C
		Foundation Fieldbus	Note 1	-50 °C to 85°C
Enclosure: IP66/ IP67	All	All	-	
IECEX (World)	Flameproof : Ga/Gb Ex d IIC T4 Ex tb IIIC T 85°C IP 66	All	Note 1	-50 °C to 85°C
	Intrinsically Safe: Ex ia IIC T4 Ex ta IIIC T 85°C IP 66	4-20 mA / DE/ HART	Note 2a	-50 °C to 70°C
		Foundation Fieldbus	Note 2b	-50 °C to 70°C
	Nonincendive: Ex nA IIC T4 Ex tc IIIC T 85°C IP 66	4-20 mA / DE/ HART/	Note 1	-50 °C to 85°C
		Foundation Fieldbus	Note 1	-50 °C to 40°C
Enclosure: IP66/ IP67	All	All	-	
SAEx (South Africa)	Flameproof : Ga/Gb Ex d IIC T4 Ex tb IIIC T 85°C IP 66	All	Note 1	-50 °C to 85°C
	Intrinsically Safe: Ex ia IIC T4 Ex ta IIIC T 85°C IP 66	4-20 mA / DE/ HART	Note 2a	-50 °C to 70°C
		Foundation Fieldbus	Note 2b	-50 °C to 70°C
	Nonincendive: Ex nA IIC T4 Ex tc IIIC T 85°C IP 66	4-20 mA / DE/ HART	Note 1	-50 °C to 85°C
		Foundation Fieldbus	Note 1	-50 °C to 85°C
Enclosure: IP66/ IP67	All	All	-	
INMETRO (Brazil)	Flameproof: Br- Ga/Gb Ex d IIC T4 Br- Ex tb IIIC T 85°C IP 66	All	Note 1	T5 Ta = -50 to 93°C
	Intrinsically Safe: Br- Ex ia IIC T4 Br- Ex ta IIIC T 85°C IP 66	4-20 mA / DE/ HART	Note 2a	T4 Ta = -50 to 93°C
		Foundation Fieldbus	Note 2b	T4 Ta = -50 to 70°C
	Nonincendive: Ex nA IIC T4 Ex tc IIIC T 85°C IP 66	4-20 mA / DE/ HART	Note 1	-50 °C to 85°C
		Foundation Fieldbus	Note 1	-50 °C to 85°C
Enclosure : IP 66/67	All	All	-	

NEPSI (China)	Flameproof: Br- Ga/Gb Ex d IIC T4 Br- Ex tb IIIC T 85°C IP 66	All	Note 1	T5 Ta = -50 to 93°C
	Intrinsically Safe: Br- Ex ia IIC T4 Br- Ex ta IIIC T 85°C IP 66	4-20 mA / DE/ HART	Note 2a	-50 °C to 70°C
		Foundation Fieldbus	Note 2b	-50 °C to 70°C
	Nonincendive: Ex nA IIC T4 Ex tc IIIC T 85°C IP 66	4-20 mA / DE/ HART	Note 1	-50 °C to 85°C
		Foundation Fieldbus	Note 1	-50 °C to 85°C
	Enclosure : IP 66/67	All	All	-

Notes:

1. Operating Parameters:

Voltage= 11 to 42 V DC Current= 4-20 mA Normal
= 10 to 30 V (FF) = 30 mA (FF)

2. Intrinsically Safe Entity Parameters

a. Analog/ DE/ HART Entity Values:

Vmax= Ui = 30V Imax= li= 105mA Ci = 4.2nF Li = 0 Pi =0.9W

b. Foundation Fieldbus- Entity Values

Vmax= Ui = 30V Imax= li= 225mA Ci = 0nF Li = 0 Pi =1W

Marine Certificates	This certificate defines the certifications covered for the ST 700 Pressure Transmitter family of products. It represents the compilation of the five certificates Honeywell currently has covering the certification of these products into marine applications.
	American Bureau of Shipping (ABS) - 2009 Steel Vessel Rules 1-1-4/3.7, 4-6-2/5.15, 4-8-3/13 & 13.5, 4-8-4/27.5.1, 4-9-7/13. Certificate number: 04-HS417416-PDA
	Bureau Veritas (BV) - Product Code: 389:1H. Certificate number: 12660/B0 BV
	Det Norske Veritas (DNV) - Location Classes: Temperature D, Humidity B, Vibration A, EMC B, Enclosure C. For salt spray exposure; enclosure of 316 SST or 2-part epoxy protection with 316 SST bolts to be applied. Certificate number: A-11476
	Korean Register of Shipping (KR) - Certificate number: LOX17743-AE001
	Lloyd's Register (LR) - Certificate number: 02/60001(E1) & (E2)
SIL 2/3 Certification	IEC 61508 SIL 2 for non-redundant use and SIL 3 for redundant use according to EXIDA and TÜV Nord Sys Tec GmbH & Co. KG under the following standards: IEC61508-1: 2010; IEC 61508-2: 2010; IEC61508-3: 2010.

Mounting & Dimensional Drawings)

Reference Dimensions: $\frac{\text{millimeters}}{\text{inches}}$

Mounting Configurations: (Dual head design)

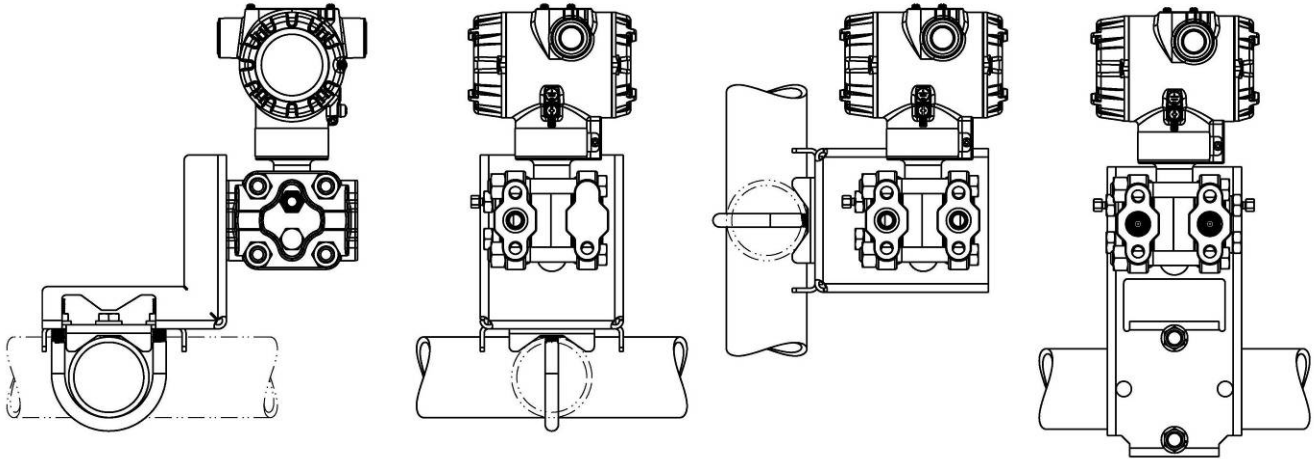

Dimensions: (Dual head design)

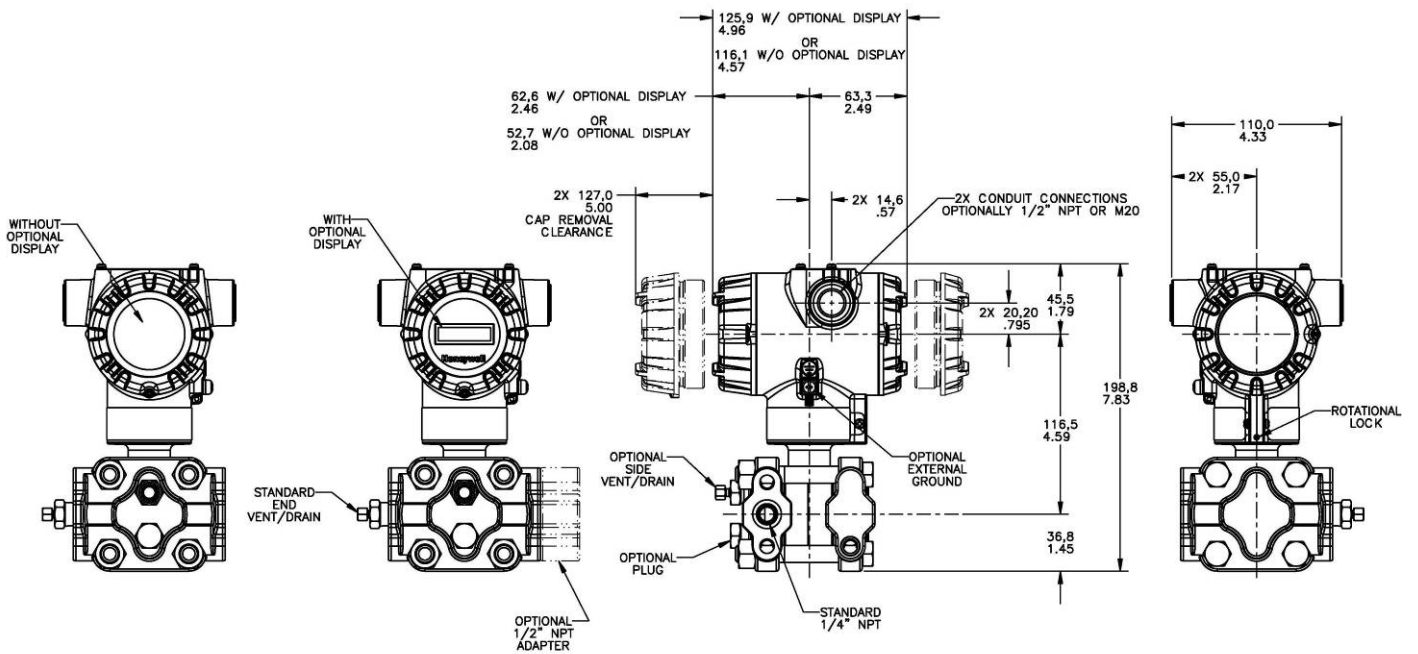
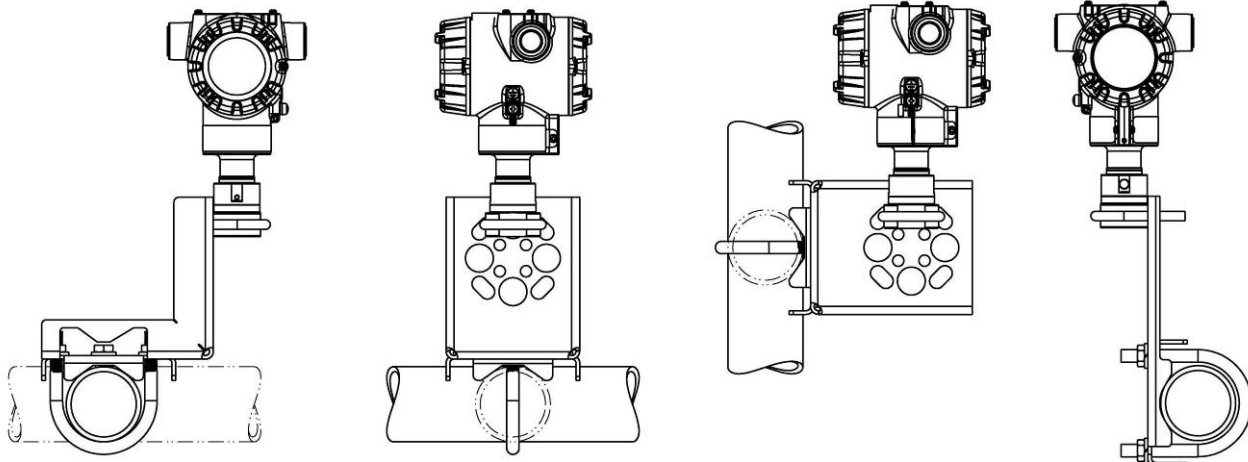

Figure 4 – Typical mounting dimensions of STG740 & STG770 for reference

Reference Dimensions: $\frac{\text{millimeters}}{\text{inches}}$

Mounting Configurations (Inline Designs)



Dimension (Inline Design)

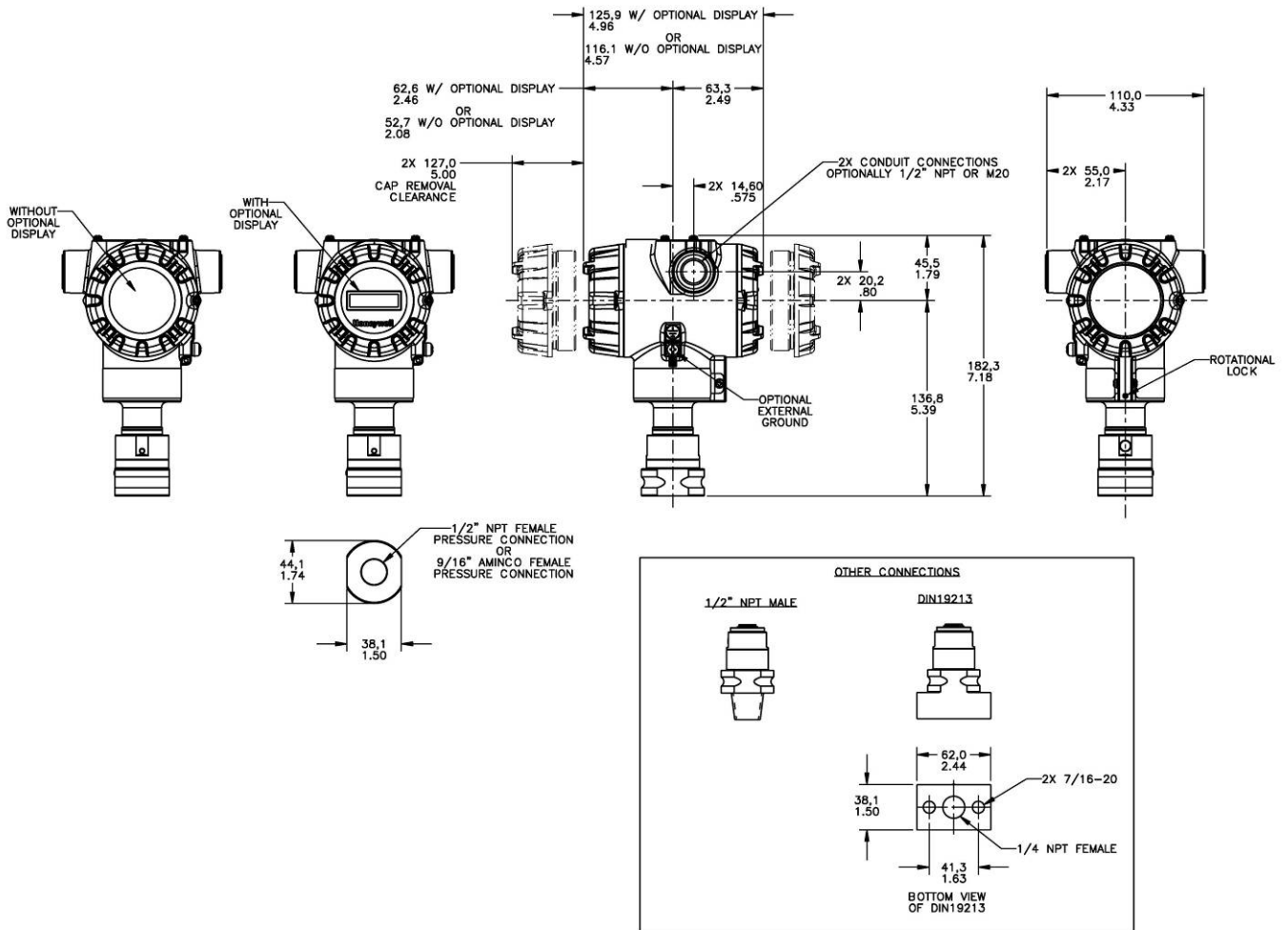

Figure 5 – Typical mounting dimensions of STG74L, STG77L, STG78L, & STG79L for reference

Model Selection Guides are subject to change and are inserted into the specifications as guidance only. Prior to specifying or ordering a model check for the latest revision Model Selection Guides which are published at:

www.honeywellprocess.com/en-US/pages/default.aspx

Model Selection Guide

Section 13
Page STG7-1

**Model STG700
Gauge Pressure Transmitters
Model Selection Guide**

Model Selection Guide
34-ST-16-102 Issue 1



Instructions: Make selections from all Tables using column below the proper arrow. Asterisk indicates availability. Letter (a) refers to restrictions highlighted in the restrictions table. Tables delimited with dashes.

Key STG - I - II - III - IV - V - VI - VII - VIII (Optional) - IX 0000

KEY NUMBER	URL/Max Span	LRL	Min Span	Units
Gauge Dual Head	50 (3.5)	-14.7 (-1.0)	0.5 (.035)	psi (bar)
	500 (35)	-14.7 (-1.0)	5 (.35)	psi (bar)
	3000 (210)	-14.7 (-1.0)	30 (2.1)	psi (bar)
Gauge In-Line	50 (3.5)	-14.7 (-1.0)	0.5 (.035)	psi (bar)
	500 (35)	-14.7 (-1.0)	5 (.35)	psi (bar)
	3000 (210)	-14.7 (-1.0)	30(2.1)	psi (bar)
	6000 (420)	-14.7 (-1.0)	60 (4.2)	psi (bar)
	10000 (690)	-14.7 (-1.0)	100 (6.9)	psi (bar)

Selection	Availability			
STG730	↓			
STG740	↓			
STG770	↓			
STG73L		↓		
STG74L		↓		✓
STG77L		↓		✓
STG78L		↓		✓
STG79L		↓		✓

TABLE I		METER BODY SELECTIONS	
		Process Head / Reference Head Material	Barrier Diaphragm Material
a. Process Head & Diaphragm Materials		Plated Carbon Steel / Plated Carbon Steel	316L SS Hastelloy® C - 276 Monel 400® Tantalum
		316 Stainless Steel / 316 Stainless Steel	316L SS Hastelloy C - 276 Monel 400 Tantalum
		Hastelloy C - 276 / 316 Stainless Steel	Hastelloy C - 276 Tantalum
		Monel 400 /	Monel 400
		Silicone Oil DC 200 Fluorinated Oil CTFE	
b. Fill Fluid			
c. Process Connection		9/16" Aminco 1/2" NPT (female) 1/2" NPT (male) DIN 19213 (1/4" female NPT)	Same as Process Head Same as Process Head ^{1a} Same as Process Head Same as Process Head
	d. Bolt/Nuts Materials	None	
		Carbon Steel	
		316 SS	
Grade 660 (NACE A286) with NACE 304 SS Nuts			
Grade 660 (NACE A286) Bolts & Nuts			
Monel K500			
Super Duplex			
B7M			
e. Vent/Drain Type/Location		Head Type	Vent/Drain Location
		None	None
		Single Ended	None
		Single Ended	Side w/Vent
		Single Ended	Side w/Center Vent
		Dual Ended	End w/Vent
		Dual Ended	End w/Center Vent
	Dual Ended	Side w/ Vent & End w/Plug	
f. Gasket Materials			Vent Material
		None	None
		Teflon® or PTFE (Glass Filled)	Matches Head Material ¹
		Viton®	Stainless Steel Only
	Graphite	Matches Head Material ¹	
		Stainless Steel only	
		Matches Head Material ¹	

A	*	*	*	*
B	*	*	*	*
C	a	a	*	*
D	*	*	*	*
E	*	*	*	*
F	*	*	*	*
G	a	a	*	*
H	*	*	*	*
J	*	*	*	*
K	*	*	*	*
L	a	a	*	*
_1	*	*	*	*
_2	*	*	*	*

_A	*	*	*	*
_G	*	*	*	*
_H	*	*	*	*
_D	*	*	*	*
_0	*	*	*	*
_C	a	a	*	*
_S	a	a	*	*
_N	*	*	*	*
_K	p	p	*	*
_M	r	r	*	*
_D	p	p	*	*
_B	*	*	*	*

_0	*	*	*	*
_1	*	*	*	*
_2	*	*	*	*
_3	t	t	*	*
_4	*	*	*	*
_5	t	t	*	*
_6	*	*	*	*
_0	*	*	*	*
_A	*	*	*	*
_B	*	*	*	*
_C	*	*	*	*

¹ Except Carbon Steel Heads shall use 316SS Vent/Drain & Plugs and or 1/2" adapters
^{1a} STG730,740,770 supplied via 1/2" flange adapter same material as process head except carbon steel shall use 316 SS

Section 13
 Page STG7-2
 Effective Date: Dec 30, 2012

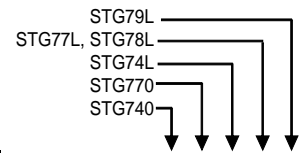

TABLE II Meter Body & Connection Orientation		
Head/Connect Orientation	Standard	High Side Left, Low Side Right ² / Std Head Orientation
	Reversed	Low Side Left, High Side Right ² / Std Head Orientation
	90/Standard	High Side Left, Low Side Right ² / 90° Head Rotation

1	*	*	*	*	*
2	*	*	*	*	*
3	h	h	*	*	*

TABLE III AGENCY APPROVALS	
Approvals	No Approvals Required
	<FM> Explosion proof, Intrinsically Safe, Non-incendive, & Dustproof
	CSA Explosion proof, Intrinsically Safe, Non-incendive, & Dustproof
	ATEX Explosion proof, Intrinsically Safe & Non-incendive
	IECEX Explosion proof, Intrinsically Safe & Non-incendive
	NEPSI Explosion proof, Intrinsically Safe & Non-incendive

0	*	*	*	*	*
A	*	*	*	*	*
B	*	*	*	*	p
C	*	*	*	*	*
D	*	*	*	*	*
G	*	*	*	*	*

TABLE IV TRANSMITTER ELECTRONICS SELECTIONS			
a. Electronic Housing Material & Connection Type	Material	Connection	Lightning Protection
	Polyester Painted Aluminum	1/2 NPT	None
	Polyester Painted Aluminum	M20	None
	Polyester Painted Aluminum	1/2 NPT	Yes
	Polyester Painted Aluminum	M20	Yes
b. Output/ Protocol	Analog Output		Digital Protocol
	4-20mA dc		HART Protocol
	4-20mA dc		DE Protocol
	none		Foundation Fieldbus
c. Customer Interface Selections	Indicator	Ext Zero, Span & Config Buttons	Languages
	None	None	None
	None	Yes (Zero/Span Only)	None
	Basic	None	EN
	Basic	Yes	EN

A __	*	*	*	*	*
B __	*	*	*	*	*
C __	*	*	*	*	*
D __	*	*	*	*	*

_ H _	*	*	*	*	*
_ D _	*	*	*	*	*
_ F _	*	*	*	*	*

__ 0	*	*	*	*	*
__ A	f	f	f	f	f
__ B	*	*	*	*	*
__ C	*	*	*	*	*

TABLE V CONFIGURATION SELECTIONS			
a. Application Software	Diagnostics		
	Standard Diagnostics		
b. Output Limit, Failsafe & Write Protect Settings	Write Protect	Fail Mode	High & Low Output Limits ³
	Disabled	High > 21.0mAdc	Honeywell Std (3.8 - 20.8 mAdc)
	Disabled	Low < 3.6mAdc	Honeywell Std (3.8 - 20.8 mAdc)
	Enabled	High > 21.0mAdc	Honeywell Std (3.8 - 20.8 mAdc)
	Enabled	Low < 3.6mAdc	Honeywell Std (3.8 - 20.8 mAdc)
	Enabled	N/A	N/A Fieldbus
	Disabled	N/A	N/A Fieldbus
c. General Configuration	General Configuration		
	Factory Standard		
	Custom Configuration (Unit Data Required from customer)		

1 __	*	*	*	*	*
------	---	---	---	---	---

_ 1 _	f	f	f	f	f
_ 2 _	f	f	f	f	f
_ 3 _	f	f	f	f	f
_ 4 _	f	f	f	f	f
_ 5 _	g	g	g	g	g
_ 6 _	g	g	g	g	g

__ S	*	*	*	*	*
__ C	*	*	*	*	*

² Left side/Right side as viewed from the customer connection perspective

³ NAMUR Output Limits are configurable by customer

Section 13
Page STG7-3
Effective Date: Dec 30, 2012

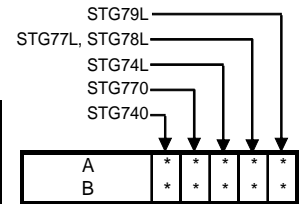

TABLE VI CALIBRATION & ACCURACY SELECTIONS			
a. Accuracy and Calibration	Accuracy	Calibrated Range	Calibration Qty
	Standard	Factory Standard	Single Calibration
	Standard	Custom (Unit Data Required)	Single Calibration

A	*	*	*	*	*	√
B	*	*	*	*	*	√

TABLE VII ACCESSORY SELECTIONS		
a. Mounting Bracket	Bracket Type	Material
	None	None
Angle Bracket	Angle Bracket	Carbon Steel
Angle Bracket	Marine Approved Angle Bracket	304 SS
Flat Bracket	Flat Bracket	Carbon Steel
Flat Bracket	Flat Bracket	304 SS
b. Customer Tag	Customer Tag Type	
	No customer tag	
	One Wired Stainless Steel Tag (Up to 4 lines 26 char/line)	
Two Wired Stainless Steel Tag (Up to 4 lines 26 char/line)		
c. Unassembled Conduit Plugs & Adapters	Unassembled Conduit Plugs & Adapters	
	No Conduit Plugs or Adapters Required	
	1/2 NPT Male to 3/4 NPT Female 316 SS Certified Conduit Adapter	
	1/2 NPT 316 SS Certified Conduit Plug	
	M20 316 SS Certified Conduit Plug	
	Minifast® 4 pin (1/2 NPT) (not suitable for X-Proof applications)	
Minifast® 4 pin (M20) (not suitable for X-Proof applications)		

0 ---	*	*	*	*	*	√
1 ---	*	*	*	*	*	√
2 ---	*	*	*	*	*	√
4 ---	*	*	*	*	*	√
5 ---	*	*	*	*	*	√
6 ---	*	*	*	*	*	√

_ 0 _ _	*	*	*	*	*	√
_ 1 _ _	*	*	*	*	*	√
_ 2 _ _	*	*	*	*	*	√

_ _ A0	*	*	*	*	*	√
_ _ A2	n	n	n	n	n	√
_ _ A6	n	n	n	n	n	√
_ _ A7	m	m	m	m	m	
_ _ A8	n	n	n	n	n	
_ _ A9	m	m	m	m	m	

TABLE VIII OTHER Certifications & Options: (String in sequence comma delimited (XX, XX, XX,....))	
Certifications & Warranty	NACE MR0175; MR0103; ISO15156 (FC33338) Process wetted parts only
	NACE MR0175; MR0103; ISO15156 (FC33339) Process wetted and non-wetted parts
	Marine (DNV, ABS, BV, KR, LR) (FC33340)
	EN10204 Type 3.1 Material Traceability (FC33341)
	Certificate of Conformance (F3391)
	Calibration Test Report & Certificate of Conformance (F3399)
	Certificate of Origin (F0195)
	FMEDA (SIL 2/3) Certification (FC33337)
Over-Pressure Leak Test Certificate (1.5X MAWP) (F3392)	
Cert Clean for O ₂ or CL ₂ service per ASTM G93	

FG	c	c	c	c	c	b	√
F7	c	c	c	c	c		√
MT	d	d	d	d	d		√
FX	*	*	*	*	*		√
F3	*	*	*	*	*	b	√
F1	*	*	*	*	*		√
F5	*	*	*	*	*		√
FE	j	j	j	j	j		√
TP	*	*	*	*	*		√
OX	e	e	e	e	e		√

TABLE IX Manufacturing Specials	
Factory	Factory Identification

0 0 0 0	*	*	*	*	*
---------	---	---	---	---	---

RESTRICTIONS

Restriction Letter	Available Only with		Not Available with	
	Table	Selection(s)	Table	Selection(s)
a			VIII	FG, F7
c	ld	_ _ _ 0,N,K,D,B _ _ _	I a	C, G, L, _ _ _ _
d			VIIa	1,2,5,6, _ _ _
e	lb	_ 2 _ _ _		
f			IV b	_ F _
g			IVb	_ H,D _
h			Ie	_ 4, 5, 6 _ _
			VIIa	1,2,4,5,6 _ _ _
j	IV b	_ H _	Vb	_ 1,2,6 _
m	IV a	B,D _ _		
n	IV a	A,C _ _		
p			III	B- No CRN number available
r			VIII	F7, FG
			III	B- No CRN number available
t			Ia	J, K, L _ _ _ _ _
b	Select Only one option from this group			

Sales and Service

For application assistance, current specifications, pricing, or name of the nearest Authorized Distributor, contact one of the offices below.

ASIA PACIFIC

(TAC)

hfs-tac-support@honeywell.com

Australia

Honeywell Limited
Phone: +(61) 7-3846 1255
FAX: +(61) 7-3840 6481
Toll Free 1300-36-39-36
Toll Free Fax:
1300-36-04-70

China – PRC - Shanghai

Honeywell China Inc.
Phone: (86-21) 5257-4568
Fax: (86-21) 6237-2826

Singapore

Honeywell Pte Ltd.
Phone: +(65) 6580 3278
Fax: +(65) 6445-3033

South Korea

Honeywell Korea Co Ltd
Phone: +(822) 799 6114
Fax: +(822) 792 9015

EMEA

Honeywell Process Solutions,
Phone: + 80012026455 or +44
(0)1202645583
FAX: +44 (0) 1344 655554

Email: (Sales)
sc-cp-apps-salespa62@honeywell.com

or
(TAC)
hfs-tac-support@honeywell.com

NORTH AMERICA

Honeywell Process Solutions,
Phone: 1-800-423-9883
Or 1-800-343-0228

Email: (Sales)
ask-ssc@honeywell.com
or
(TAC)
hfs-tac-support@honeywell.com

SOUTH AMERICA

Honeywell do Brasil & Cia
Phone: +(55-11) 7266-1900
FAX: +(55-11) 7266-1905

Email: (Sales)
ask-ssc@honeywell.com
or
(TAC)
hfs-tac-support@honeywell.com

Specifications are subject to change without notice.

For More Information

Learn more about how Honeywell's Smartline Smart Pressure Transmitters can increase performance, reduce downtime and decrease configuration costs, visit our website www.honeywellprocess.com or contact your Honeywell account manager.

Honeywell Process Solutions

1860 West Rose Garden Lane
Phoenix, Arizona 85027
Tel: 1-800-423-9883 or 1-800-343-0228
www.honeywellprocess.com

34-ST-03-102
February 2013
© 2013 Honeywell International Inc.

Honeywell