

### STA700 SmartLine Absolute Pressure Specification 34-ST-03-100



#### Introduction

Part of the SmartLine® family of products, the STA700 and STA70L are suitable for monitoring, control and data acquisition. STA70X products feature piezoresistive sensor technology combining pressure sensing with on chip temperature compensation capabilities providing high accuracy, stability and performance over a wide range of application pressures and temperatures. The SmartLine family is also fully tested and compliant with Experion® PKS providing the highest level of compatibility assurance and integration capabilities. SmartLine easily meets the most demanding application needs for pressure measurement applications.

#### Best in Class Features:

- Accuracy up to 0.065 % of calibrated span
- Automatic temperature compensation
- Rangeability up to 100:1
- Response times as fast as 100ms
- Alphanumeric display capabilities
- External zero, span, & configuration capability
- Polarity insensitive electrical connections
- On-board diagnostic capabilities
- Integral Dual Seal design for safety based on ANSI/NFPA 70-202 and ANSI/ISA 12.27.0
- Full compliance to SIL 2/3 requirements as a standard.
- Modular design characteristics

#### Span & Range Limits:

Model	URL mmHgA (mbarA)	LRL mmHgA (mbarA)	Min Span mm HgA (mbarA)	MAWP mmHgA (mbarA)
STA722/72L	780 (1040)	0 (0)	50 (65.0)	780 (1040)
Model	psia (barA)	psi (barA)	psi (barA)	psia (barA)
STA740/74L	500 (35)	0 (0)	5 (.35)	500 (35)
STA77L	3000 (210)	0 (0)	30 (2.1)	3000 (210)



Figure 1 – STA700 Absolute Pressure Transmitters feature field-proven piezoresistive sensor technology

#### Communications/Output Options:

- Honeywell Digitally Enhanced (DE)
- HART® (version 7.0)
- FOUNDATION™ Fieldbus

All transmitters are available with the above listed communications protocols.

## Description

The SmartLine family pressure transmitters are designed around a high performance piezo-resistive sensor. This one sensor actually integrates multiple sensors linking process pressure measurement with on-board static pressure (DP Models) and temperature compensation measurements. This level of performance allows the ST 700 to replace most competitive transmitters available today.

## Indication/Display Option

The ST 700 modular design accommodates a basic alphanumeric LCD display.

### Basic Alphanumeric LCD Display Features

- Modular (may be added or removed in the field)
- 0, 90,180, & 270 degree position adjustments
- Pa, KPa, MPa, KGcm2, Torr, ATM, i4H<sub>2</sub>O, mH<sub>2</sub>O, bar, mbar, inH<sub>2</sub>O, inHG, FTH<sub>2</sub>O, mmH<sub>2</sub>O, mm HG, & psi measurement units
- 2 Lines 16 Characters (4.13H x 1.83W mm)
- Square root output indication

## Diagnostics

SmartLine transmitters all offer digitally accessible diagnostics which aid in providing advanced warning of possible failure events minimizing unplanned shutdowns, providing **lower overall operational costs**

## Configuration Tools

### Integral Three Button Configuration Option

Suitable for all electrical and environmental requirements, SmartLine offers the ability to configure the transmitter and display via three externally accessible buttons when a display option is selected. Zero/span capabilities are also optionally available via these buttons with or without selection of the display option.

### Hand Held Configuration

SmartLine transmitters feature two-way communication and configuration capability between the operator and the transmitter. This is accomplished via Honeywell's field-rated Multiple Communication Configurator (MCT202).

The MCT202 is capable of field configuring DE and HART Devices and can also be ordered for use in intrinsically safe environments. All Honeywell transmitters are designed and tested for compliance with the offered communication protocols and are designed to operate with any properly validated hand held configuration device.

### Personal Computer Configuration

Honeywell's SCT 3000 Configuration Toolkit provides an easy way to configure Digitally Enhanced (DE) instruments using a personal computer as the configuration interface. Field Device Manager (FDM) Software and FDM Express are also available for managing HART & Fieldbus device configurations.

## System Integration

- SmartLine communications protocols all meet the most current published standards for HART/DE/Fieldbus.
- Integration with Honeywell's Experion PKS offers the following unique advantages.
  - Tamper reporting
  - FDM Plant Area Views with Health summaries
  - All ST 700 units are Experion tested to provide the highest level of compatibility assurance

## Modular Design

To help contain maintenance & inventory costs, all ST 700 transmitters are modular in design supporting the user's ability to replace meter bodies, add indicators or change electronic modules without affecting overall performance or approval body certifications. Each meter body is uniquely characterized to provide in-tolerance performance over a wide range of application variations in temperature and pressure and due to the Honeywell advanced interface, electronic modules may be swapped with any electronics module without losing in-tolerance performance characteristics.

### Modular Features

- Meter body replacement
- Exchange/replace electronics/comms modules\*
- Add or remove integral indicator\*
- Add or remove lightning protection (terminal connection)\*

\* Field replaceable in all electrical environments (including IS) except flameproof without violating agency approvals.

With no performance effects, Honeywell's unique modularity results in **lower inventory needs and lower overall operating costs**.

**Performance Specifications<sup>1</sup>**

**Reference Accuracy<sup>2</sup>:**(conformance to +/-3 Sigma)

Model	URL	LRL	Min Span	Maximum Turndown Ratio	Reference Accuracy % Span
STA722	780 mmHgA (1040 mbarA)	0.0 mmHgA (0.0 mbarA)	50 mmHgA (65.0 mbarA)	15:1	<b>0.065%</b>
STA740	500 psia (35 barA)	0.0 mmHgA (0.0 mbarA)	5 psia (0.35 barA)	100:1	
STA72L	780 mmHgA (1040 mbarA)	0.0 mmHgA (0.0 mbarA)	50 mmHgA (65.0 mbarA)	15:1	
STA74L	500 psia (35 barA)	0.0 mmHgA (0.0 mbarA)	5 psia (0.35 barA)	100:1	
STA77L	3000 psi (210 barA)	0.0 mmHgA (0.0 mbarA)	30 psia (2.1 barA)	100:1	

Zero and span may be set anywhere within the listed (URL/LRL) range limits

**Accuracy at Specified Span and Temperature:** (conformance to +/-3 Sigma)

Model	URL	Turn downs greater than	Accuracy <sup>1</sup> (% of Span)			Temperature Effect (% Span/50°F)	
			A	B	C (see URL units)	D	E
STA722	780 mmHgA (1040 mbarA)	8:1	0.015	0.05	90(120)	0.065	0.045
STA740	500 psia (35 barA)	25:1			20(1.4)	0.050	0.010
STA72L	780 mmHgA (1040 mbarA)	5:1			140(187)	0.065	0.100
STA74L	500 psia (35 barA)	25:1			20(1.4)	0.050	0.015
STA77L	3000 psi (210 barA)	6:1			500(35)	0.050	0.010
			<b>Turn Down Effect</b> $\pm \left[ A + B \left( \frac{C}{\text{Span}} \right) \right]$ % Span			<b>Temp Effect</b> $\pm \left[ D + E \left( \frac{\text{URL}}{\text{Span}} \right) \right]$ % Span per 28°C (50°F)	

**Total Performance (% of Span):**

**Total Performance Calculation:** = +/-  $\sqrt{(\text{Accuracy})^2 + (\text{Temperature Effect})^2}$

**Total Performance Examples (for comparison):** @ 5:1 Turndown, +/-50 °F (28°C) shift

**STA722 @ 156 mmHgA:** 0.297% of span

**STA72L @ 156 mmHgA:** 0.569% of span

**STA740 @ 100 psia:** 0.119% of span

**STA74L @ 100 psia:** 0.141% of span

**STA77L @ 600 psia:** 0.119% of span

**Typical Calibration Frequency:**

Calibration verification is recommended every two (2) years

**Notes:**

1. Terminal Based Accuracy - Includes combined effects of linearity, hysteresis, and repeatability. Analog output adds 0 .005% of span.
2. For zero based spans and reference conditions of: 25 °C (77oF), 10 to 55% RH, and 316 Stainless Steel barrier diaphragm.

**Operating Conditions – All Models**

Parameter	Reference Condition		Rated Condition		Operative Limits		Transportation and Storage	
	°C	°F	°C	°F	°C	°F	°C	°F
<b>Ambient Temperature<sup>1</sup></b>	25±1	77±2	-40 to 85	-40 to 185	-40 to 85	-40 to 185	-55 to 120	-67 to 248
<b>Meter Body Temperature<sup>2</sup></b>								
STA722/STA72L	25±1	77±2	See Figure 1		See Figure 1		-55 to 125	-67 to 257
STA740, 74L, 77L	25±1	77±2	-40 to 110	-40 to 230	-40 to 125	-40 to 257	-55 to 125	-67 to 257
<b>Humidity %RH</b>	10 to 55		0 to 100		0 to 100		0 to 100	
<b>Vacuum Region - Minimum Pressure</b> STA722, 72L, 740, 74L, 77L	See Figure 2. Operate within specifications above 25 mmHgA (33 mbarA). Short term <sup>3</sup> exposure to full vacuum will not result in damage.							
<b>Supply Voltage, Current, and Load Resistance (HART &amp; DE)</b>	10.8 to 42.4 Vdc at terminals (IS versions limited to 30 Vdc) 0 to 1,440 ohms (as shown in Figure 3)							
<b>Maximum Allowable Working Pressure (MAWP)<sup>4, 5</sup></b>	STA722, 72L = 780 mmHgA, 1,040 mbarA STA740, 74L = 500 psia, 35 barA STA77L = 3,000 psia, 210 barA							

<sup>1</sup> LCD Display operating temperature -20°C to +70°C Storage temperature -30°C to 80°C.

<sup>2</sup> For CTFE fill fluid, the rating is -15 to 110°C (5 to 230°F)

<sup>3</sup> Short term equals 2 hours at 70°C (158°F)

<sup>4</sup> Units can withstand overpressure of 1.5 x MAWP without damage

<sup>5</sup> Consult factory for MAWP of ST 700 transmitters with CRN approval

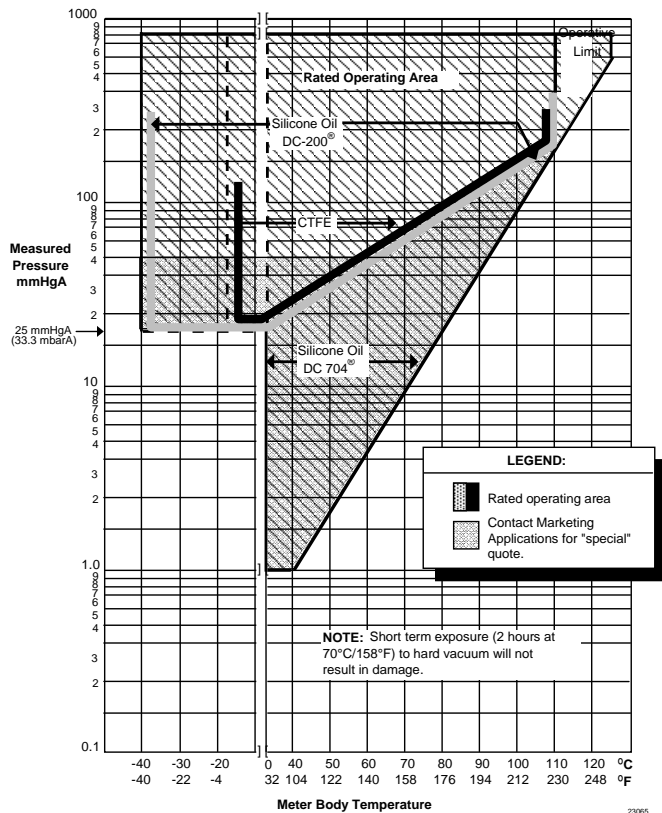

Figure 2 – Measured pressure versus meter body temperature chart for STA722, 72L

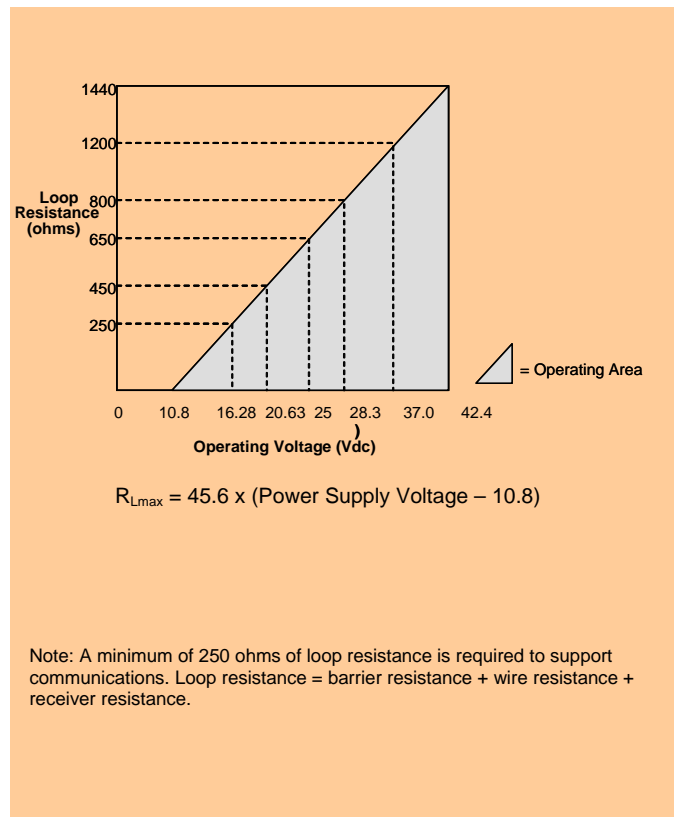

Figure 3 - Supply voltage and loop resistance chart & calculations

**Performance Under Rated Conditions – All Models**

Parameter	Description									
<b>Analog Output</b> <b>Digital Communications:</b>	Two-wire, 4 to 20 mA (HART & DE Transmitters only) Honeywell DE, HART 7 protocol or FOUNDATION Fieldbus ITK 6.0.1 compliant All transmitters, irrespective of protocol have polarity insensitive connection.									
<b>Output Failure Modes</b>	<table style="width: 100%; border: none;"> <tr> <td style="width: 33%;"></td> <td style="text-align: center;"><b>Honeywell Standard:</b></td> <td style="text-align: center;"><b>NAMUR NE 43 Compliance:</b></td> </tr> <tr> <td><b>Normal Limits:</b></td> <td style="text-align: center;">3.8 – 20.8 mA</td> <td style="text-align: center;">3.8 – 20.5 mA</td> </tr> <tr> <td><b>Failure Mode:</b></td> <td style="text-align: center;">≤ 3.6 mA and ≥ 21.0 mA</td> <td style="text-align: center;">≤ 3.6 mA and ≥ 21.0 mA</td> </tr> </table>		<b>Honeywell Standard:</b>	<b>NAMUR NE 43 Compliance:</b>	<b>Normal Limits:</b>	3.8 – 20.8 mA	3.8 – 20.5 mA	<b>Failure Mode:</b>	≤ 3.6 mA and ≥ 21.0 mA	≤ 3.6 mA and ≥ 21.0 mA
	<b>Honeywell Standard:</b>	<b>NAMUR NE 43 Compliance:</b>								
<b>Normal Limits:</b>	3.8 – 20.8 mA	3.8 – 20.5 mA								
<b>Failure Mode:</b>	≤ 3.6 mA and ≥ 21.0 mA	≤ 3.6 mA and ≥ 21.0 mA								
<b>Supply Voltage Effect</b>	0.005% of span per volt.									
<b>Transmitter Turn on Time</b> (includes power up & test algorithms)	HART or DE: 2.5 sec Foundation Fieldbus: Host dependant									
<b>Response Time</b> (delay + time constant)	<table style="width: 100%; border: none;"> <tr> <td style="text-align: center;"><u><b>DE/HART Protocol</b></u></td> <td style="text-align: center;"><u><b>FOUNDATION Fieldbus</b></u></td> </tr> <tr> <td style="text-align: center;">100ms</td> <td style="text-align: center;">150ms (Host Dependant)</td> </tr> </table>	<u><b>DE/HART Protocol</b></u>	<u><b>FOUNDATION Fieldbus</b></u>	100ms	150ms (Host Dependant)					
<u><b>DE/HART Protocol</b></u>	<u><b>FOUNDATION Fieldbus</b></u>									
100ms	150ms (Host Dependant)									
<b>Damping Time Constant</b>	<b>HART:</b> Adjustable from 0 to 32 seconds in 0.1 increments. <b>Default Value:</b> 0.5 seconds <b>DE:</b> Discrete values 0, .16, .32, .48, 1, 2, 4, 8, 16, 32 seconds. <b>Default Value:</b> 0.48 seconds									
<b>Vibration Effect</b>	Less than +/- 0.1% of URL w/o damping Per IEC60770-1 field or pipeline, high vibration level (10-2000Hz: 0.21 displacement/3g max acceleration)									
<b>Electromagnetic Compatibility</b>	Meets IEC61326-3-1									
<b>Lightning Protection Option</b>	<b>Leakage Current:</b> 10uA max @ 42.4VDC 93C <b>Impulse rating:</b> 8/20uS      5000A (>10 strikes)      10000A (1 strike min.) 10/1000uS    200A (> 300 strikes)									

**Materials Specifications** (see model selection guide for availability/restrictions with various models)

Parameter	Description
<b>Barrier Diaphragms Material</b>	<b>STA700:</b> 316L SS, Hastelloy <sup>®</sup> C-276 <sup>2</sup> , Monel <sup>®</sup> 400 <sup>3</sup> , Tantalum <b>STA70L:</b> 316L SS, Hastelloy C-276
<b>Process Head Material</b>	<b>STA700:</b> Carbon Steel (Zinc Plated) <sup>5</sup> , 316 SS <sup>4</sup> , Hastelloy <sup>®</sup> C-276 <sup>6</sup> , Monel <sup>®</sup> 400 <sup>7</sup> <b>STG70L:</b> 316 SS <sup>4</sup>
<b>Vent/Drain Valves &amp; Plugs</b> <sup>1</sup>	<b>STA700:</b> 316 SS <sup>4</sup> , Hastelloy C-276 <sup>2</sup> , Monel 400 <sup>7</sup> <b>STA70L:</b> N/A
<b>Head Gaskets</b>	<b>STA700:</b> Glass-filled PTFE standard. Viton <sup>®</sup> and graphite are optional. <b>STA70L:</b> N/A
<b>Meter Body Bolting</b>	<b>STA700:</b> Carbon Steel (Zinc plated) standard. Options include 316 SS, NACE A286 SS bolts and nuts or NACE A286 SS bolts and 304 SS nuts <b>STA70L:</b> N/A
<b>Mounting Bracket</b>	Carbon Steel (Zinc-plated) or 304 Stainless Steel angle bracket or Carbon Steel flat bracket available .with 2" pipe bracket. See Figures 4 & 5
<b>Fill Fluid</b>	Silicone DC <sup>®</sup> 200 oil or CTFE (Chlorotrifluoroethylene).
<b>Electronic Housing</b>	Pure Polyester Powder Coated Low Copper (<0.6%)-Aluminum. Meets NEMA 4X, IP66, IP67 and NEMA 7 (explosion proof). All stainless steel housing is optional.
<b>Process Connections</b>	<b>STA700:</b> ½ -inch NPT(female), DIN 19213 (standard) <b>STA70L:</b> ½ -inch NPT(female), ½ -inch NPT male, 9/16 Aminco, DIN19213
<b>Wiring</b>	Accepts up to 16 AWG (1.5 mm diameter).
<b>Dimensions</b>	See Figure 4 & 5
<b>Net Weight</b>	<b>STA700:</b> 8.3 pounds (3.8 Kg). <b>STA70L:</b> 3.6 pounds (1.6 Kg) with Aluminum Housing

<sup>1</sup> Vent/Drains are sealed with Teflon<sup>®</sup><sup>2</sup> Hastelloy<sup>®</sup> C-276 or UNS N10276<sup>3</sup> Monel<sup>®</sup> 400 or UNS N04400<sup>4</sup> Supplied as 316 SS or as Grade CF8M, the casting equivalent of 316 SS.<sup>5</sup> Carbon Steel heads are zinc-plated and not recommended for water service due to hydrogen migration. For that service, use 316 stainless steel wetted Process Heads.<sup>6</sup> Hastelloy<sup>®</sup> C-276 or UNS N10276. Supplied as indicated or as Grade CW12MW, the casting equivalent of Hastelloy<sup>®</sup> C-276<sup>7</sup> Monel<sup>®</sup> 400 or UNS N04400. Supplied as indicated or as Grade M30C, the casting equivalent of Monel<sup>®</sup> 400

## Communications Protocols & Diagnostics

### HART Protocol

#### Version:

HART 7

#### Power Supply

Voltage: 10.8 to 42.4Vdc at terminals

Load: Maximum 1440 ohms See figure 2

Minimum Load: 0 ohms. (For handheld communications a minimum load of 250 ohms is required)

### Foundation Fieldbus (FF)

#### Power Supply Requirements

Voltage: 9.0 to 32.0Vdc at terminals

Steady State Current: 17.6mAdc

Software Download Current: 27.4mAdc

#### Available Function Blocks

Block Type	Qty	Execution Time
Resource	1	n/a
Transducer	1	n/a
Diagnostic	1	n/a
Analog Input	1*	30 ms
PID w/Autotune	1	45 ms
Integrator	1	30 ms
Signal Char (SC)	1	30 ms
LCD Display	1	n/a
Flow Block	1	30 ms
Input Selector	1	30 ms
Arithmetic	1	30 ms

\* All block may have two (2) additional instantiations.

All available function blocks adhere to FOUNDATION Fieldbus standards. PID blocks support ideal & robust PID algorithms with full implementation of Auto-tuning.

#### Link Active Scheduler

Transmitters can perform as a backup Link Active Scheduler and take over when the host is disconnected.

Acting as a LAS, the device ensures scheduled data transfers typically used for the regular, cyclic transfer of control loop data between devices on the Fieldbus.

#### Number of Devices/Segment

Entity IS model: 6 devices/segment

#### Schedule Entries

18 maximum schedule entries

#### Number of VCR's: 24 max

**Compliance Testing:** Tested according to ITK 6.0.1

### Software Download

Utilizes Class-3 of the Common Software Download procedure as per FF-883 which allows the field devices of any manufacturer to receive software upgrades from any host.

### Honeywell Digitally Enhanced (DE)

DE is a Honeywell proprietary protocol which provides digital communications between Honeywell DE enabled field devices and Hosts.

#### Power Supply

Voltage: 10.8 to 42.4Vdc at terminals

Load: Maximum 1440 ohms See figure 2

### Standard Diagnostics

ST 700 top level diagnostics are reported as either critical or non-critical and readable via the DD/DTM tools or integral display as shown below.

#### Critical Diagnostics

HART DD/DTM tools	Basic Display
Electronic Module DAC Failure	Electronics Module fault
Meter Body NVM Corrupt	Meterbody fault
Config Data Corrupt	Electronics Module fault
Electronic Module Diag Failure	Electronics Module fault
Meter Body Critical Failure	Meterbody fault
Sensor Comm Timeout	Meterbody Comm fault

#### Non-Critical Diagnostics

HART DD/DTM tools
Display Failure
Electronic Module Comm Failure
Meter Body Excess Correct
Sensor Over Temperature
Fixed Current Mode
PV Out of Range
No Factory Calibration
No DAC Compensation
LRV Set Error – Zero Config Button
URV Set Error – Span Config Button
AO Out of Range
Loop Current Noise
Meter Body Unreliable Comm
Tamper Alarm
No DAC Calibration
Sensor Supply Voltage Low

Refer to ST 700 diagnostics tech note for additional level diagnostic information.

### Other Certification Options

#### Materials

- NACE MRO175, MRO103, ISO15156



**Approval Certifications:**

AGENCY	TYPE OF PROTECTION	COMM. OPTION	FIELD PARAMETERS	AMBIENT TEMP (Ta)
<b>FM Approvals™</b>	<b>Explosionproof:</b> Class I, Division 1, Groups A, B, C, D; <b>Dust Ignition Proof:</b> Class II, III, Division 1, Groups E, F, G; T4  Class I, Zone 1/2, AEx d IIC T4 Class II, Zone 21, AEx tb IIIC T 95°C IP 66	All	Note 1	-50 °C to 85°C
	<b>Intrinsically Safe:</b> Class I, II, III, Division 1, Groups A, B, C, D, E, F, G; T4  Class I, Zone 0, AEx ia IIC T4 Class II, Zone 20, AEx ta IIIC T 95°C IP 66	4-20 mA / DE/ HART	Note 2a	-50 °C to 70°C
		Foundation Fieldbus	Note 2b	-50 °C to 70°C
	<b>Nonincendive:</b> Class I, Division 2, Groups A, B, C, D locations,  Class I, Zone 2, AEx nA IIC T4 Class II, Zone 22, AEx tc IIIC T 95°C IP 66	4-20 mA / DE/ HART	Note 1	-50 °C to 85°C
		Foundation Fieldbus	Note 1	-50 °C to 85°C
	Enclosure: Type 4X/ IP66/ IP67	All	All	-
<b>Canadian Standards Association (CSA)</b>	<b>Explosion Proof:</b> Class I, Division 1, Groups A, B, C, D; <b>Dust Ignition Proof:</b> Class II, III, Division 1, Groups E, F, G; T4  Ex d IIC T4 Ex tb IIIC T 95°C IP 66	All	Note 1	-50 °C to 85°C
	<b>Intrinsically Safe:</b> Class I, II, III, Division 1, Groups A, B, C, D, E, F, G; T4  Ex nA IIC T4 Ex tc IIIC T 95°C IP 66	4-20 mA / DE/ HART	Note 2a	-50 °C to 70°C
		Foundation Fieldbus	Note 2b	-50 °C to 70°C
	<b>Nonincendive:</b> Class I, Division 2, Groups A, B, C, D; T4  Ex nA IIC T4 Ex tc IIIC T 95°C IP 66	4-20 mA / DE/ HART	Note 1	-50 °C to 85°C
		Foundation Fieldbus- FNICO	Note 1	-50 °C to 85°C
	Enclosure: Type 4X/ IP66/ IP67	All	All	-
	<b>Canadian Registration Number (CRN):</b>	All models have been registered in all provinces and territories in Canada and are marked CRN: 0F8914.5C.		

## Approval Certifications: (Continued)

<b>ATEX</b>	<b>Flameproof:</b> II 1/2 G Ex d IIC T4 II 2 D Ex tb IIIC T 85°C IP 66	All	Note 1	-50 °C to 85°C
	<b>Intrinsically Safe:</b> II 1 G Ex ia IIC T4	4-20 mA / DE/ HART	Note 2a	-50 °C to 70°C
		Foundation Fieldbus	Note 2b	-50 °C to 70°C
	<b>Nonincendive:</b> II 3 G Ex nA IIC T4	4-20 mA / DE/ HART	Note 1	-50 °C to 85°C
		Foundation Fieldbus	Note 1	-50 °C to 40°C
<b>Enclosure:</b> IP66/ IP67	All	All	-	
<b>IECEX (World)</b>	<b>Flameproof :</b> Ga/Gb Ex d IIC T4 Ex tb IIIC T 85°C IP 66	All	Note 1	-50 °C to 85°C
	<b>Intrinsically Safe:</b> Ex ia IIC T4	4-20 mA / DE/ HART	Note 2a	-50 °C to 70°C
		Foundation Fieldbus	Note 2b	-50 °C to 70°C
	<b>Nonincendive:</b> Ex nA IIC T4	4-20 mA / DE/ HART	Note 1	-50 °C to 85°C
		Foundation Fieldbus	Note 1	-50 °C to 85°C
<b>Enclosure:</b> IP66/ IP67	All	All	-	
<b>SAEx (South Africa)</b>	<b>Flameproof :</b> Ga/Gb Ex d IIC T4 Ex tb IIIC T 85°C IP 66	All	Note 1	-50 °C to 85°C
	<b>Intrinsically Safe:</b> Ex ia IIC T4	4-20 mA / DE/ HART	Note 2a	-50 °C to 70°C
		Foundation Fieldbus	Note 2b	-50 °C to 70°C
	<b>Nonincendive:</b> Ex nA IIC T4	4-20 mA / DE/ HART	Note 1	-50 °C to 85°C
		Foundation Fieldbus	Note 1	-50 °C to 85°C
<b>Enclosure:</b> IP66/ IP67	All	All	-	
<b>INMETRO (Brazil)</b>	<b>Flameproof:</b> Br- Ga/Gb Ex d IIC T4 Br- Ex tb IIIC T 85°C IP 66	All	Note 1	-50 °C to 85°C
	<b>Intrinsically Safe:</b> Br- Ex ia IIC T4	4-20 mA / DE/ HART	Note 2a	-50 °C to 70°C
		Foundation Fieldbus	Note 2b	-50 °C to 70°C
	<b>Nonincendive:</b> Ex nA IIC T4	4-20 mA / DE/ HART	Note 1	-50 °C to 85°C
		Foundation Fieldbus	Note 1	-50 °C to 85°C
<b>Enclosure :</b> IP 66/67	All	All	-	



<b>NEPSI (China)</b>	<b>Flameproof:</b> Br- Ga/Gb Ex d IIC T4 Br- Ex tb IIIC T 85°C IP 66	All	Note 1	-50 °C to 85°C
	<b>Intrinsically Safe:</b> Br- Ex ia IIC T4	4-20 mA / DE/ HART	Note 2a	-50 °C to 70°C
		Foundation Fieldbus	Note 2b	-50 °C to 70°C
	<b>Nonincendive:</b> Ex nA IIC T4	4-20 mA / DE/ HART	Note 1	-50 °C to 85°C
		Foundation Fieldbus	Note 1	-50 °C to 85°C
	<b>Enclosure :</b> IP 66/67	All	All	-

Notes:

1. Operating Parameters:

Voltage= 11 to 42 V DC                      Current= 4-20 mA Normal (3.8 – 23 mA Faults)  
 = 10 to 30 V (FF)                              = 30 mA (FF)

2. Intrinsically Safe Entity Parameters

a. Analog/ DE/ HART Entity Values:

Vmax= Ui = 30V                      Imax= li= 105mA                      Ci = 4.2nF                      Li = 0                      Pi =0.9W

b. Foundation Fieldbus- Entity Values

Vmax= Ui = 30V                      Imax= li= 225mA                      Ci = 0nF                      Li = 0                      Pi =1W

<b>Marine Certificates</b>	This certificate defines the certifications covered for the ST 700 Pressure Transmitter family of products, including. It represents the compilation of the five certificates Honeywell currently has covering the certification of these products into marine applications.
	<b>American Bureau of Shipping (ABS)</b> - 2009 Steel Vessel Rules 1-1-4/3.7, 4-6-2/5.15, 4-8-3/13 & 13.5, 4-8-4/27.5.1, 4-9-7/13. Certificate number: 04-HS417416-PDA
	<b>Bureau Veritas (BV)</b> - Product Code: 389:1H. Certificate number: 12660/B0 BV
	<b>Det Norske Veritas (DNV)</b> - Location Classes: Temperature D, Humidity B, Vibration A, EMC B, Enclosure C. For salt spray exposure; enclosure of 316 SST or 2-part epoxy protection with 316 SST bolts to be applied. Certificate number: A-11476
	<b>Korean Register of Shipping (KR)</b> - Certificate number: LOX17743-AE001
	<b>Lloyd's Register (LR)</b> - Certificate number: 02/60001(E1) & (E2)
<b>SIL 2/3 Certification</b>	IEC 61508 SIL 2 for non-redundant use and SIL 3 for redundant use according to EXIDA and TÜV Nord Sys Tec GmbH & Co. KG under the following standards: IEC61508-1: 2010; IEC 61508-2: 2010; IEC61508-3: 2010.

**Mounting & Dimensional Drawings)**

Reference Dimensions:  $\frac{\text{millimeters}}{\text{inches}}$

**Mounting Configurations (Dual head design)**

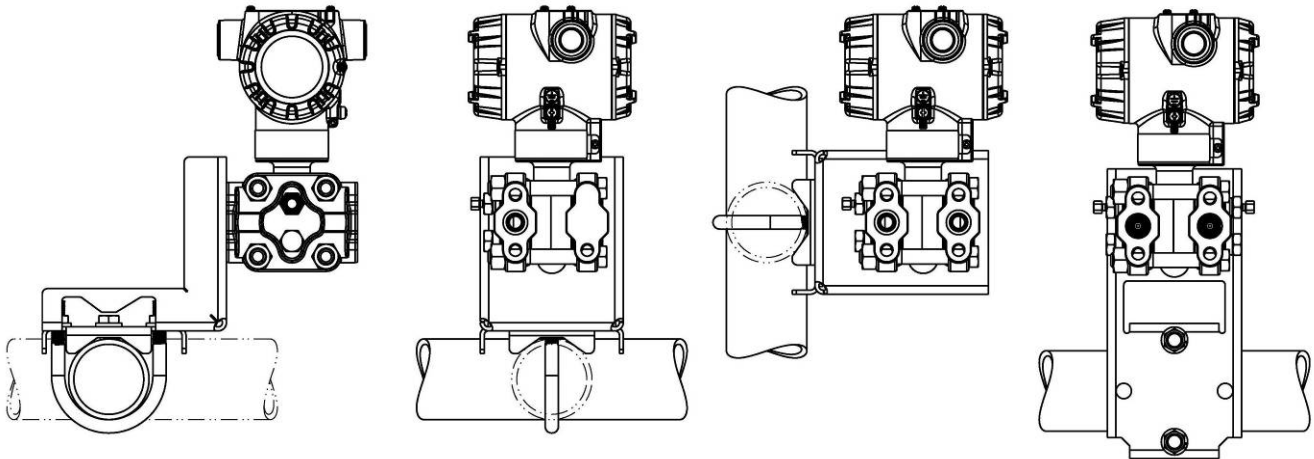

**Dimensions (Dual head design)**

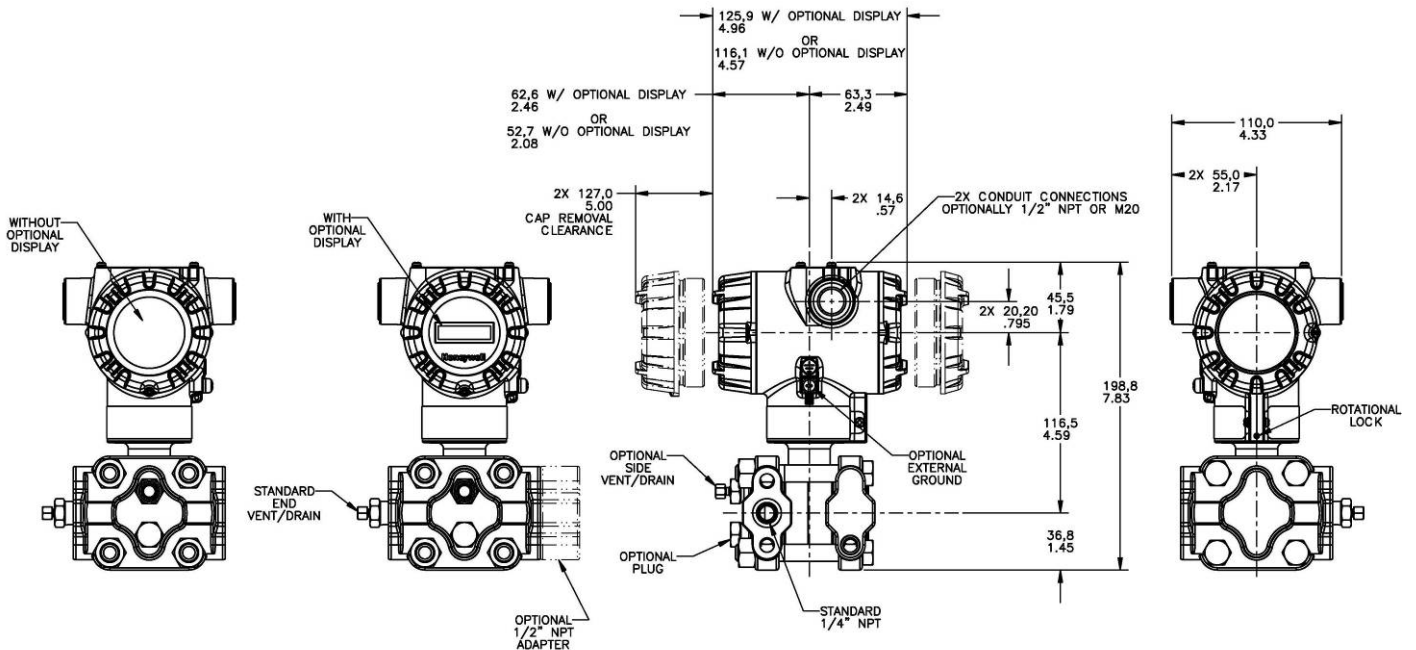

**Figure 4** – Typical mounting dimensions of STA722 & STA740 for reference

Reference Dimensions:  $\frac{\text{millimeters}}{\text{inches}}$

**Mounting Configurations (Inline Designs)**

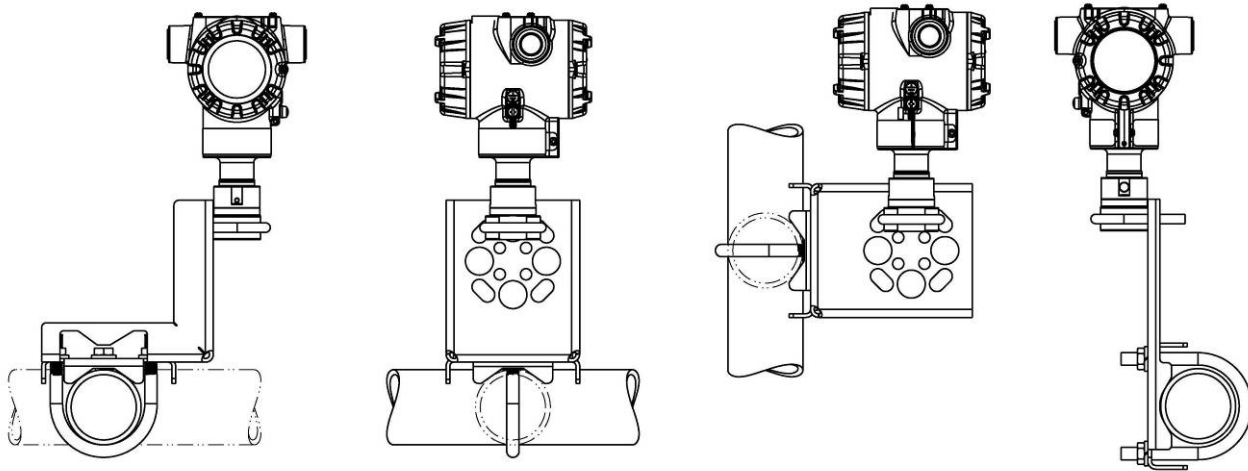

**Dimension (Inline Design)**

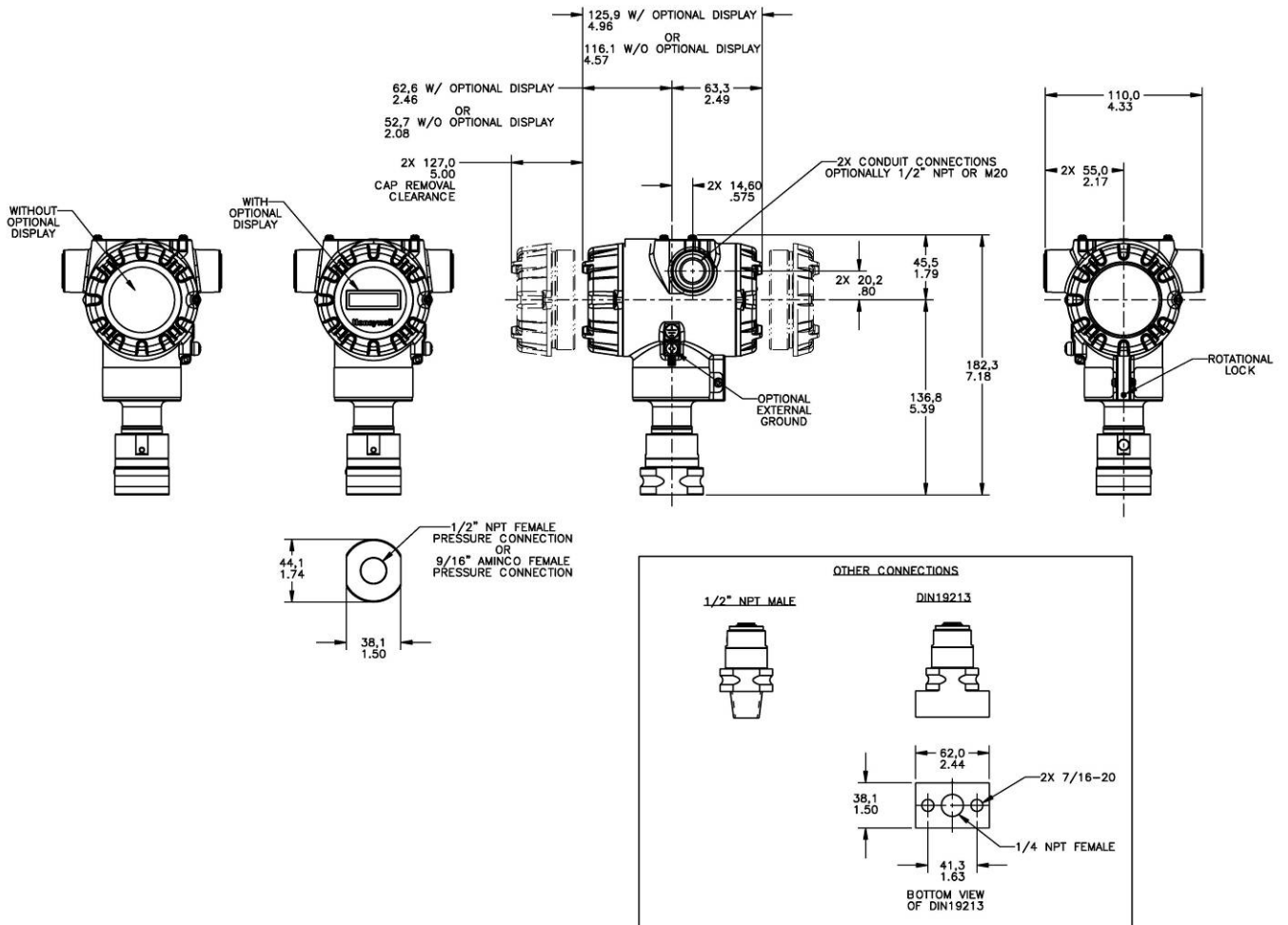

**Figure 5** – Typical mounting dimensions of STA72L, STA74L, & STA77L for reference



**Section 13**  
**Page STA7-2**  
**Effective Date: Dec 30, 2012**



TABLE II Meter Body & Connection Orientation		
Head/Connect Orientation	Standard	High Side Left, Low Side Right <sup>2</sup> / Std Head Orientation
	Reversed	Low Side Left, High Side Right <sup>2</sup> / Std Head Orientation
	90/Standard	High Side Left, Low Side Right <sup>2</sup> / 90 <sup>o</sup> Head Rotation

1	*	*	√
2	*		
3	h		

TABLE III AGENCY APPROVALS	
Approvals	No Approvals Required
	<FM> Explosion proof, Intrinsically Safe, Non-incendive, & Dustproof
	CSA Explosion proof, Intrinsically Safe, Non-incendive, & Dustproof
	ATEX Explosion proof, Intrinsically Safe & Non-incendive
	IECEX Explosion proof, Intrinsically Safe & Non-incendive
	NEPSI Explosion proof, Intrinsically Safe & Non-incendive

0	*	*	√
A	*	*	√
B	*	*	√
C	*	*	√
D	*	*	√
G	*	*	√

TABLE IV TRANSMITTER ELECTRONICS SELECTIONS			
a. Electronic Housing Material & Connection Type	Material	Connection	Lightning Protection
	Polyester Painted Aluminum	1/2 NPT	None
	Polyester Painted Aluminum	M20	None
	Polyester Painted Aluminum	1/2 NPT	Yes
	Polyester Painted Aluminum	M20	Yes
b. Output/ Protocol	Analog Output		Digital Protocol
	4-20mA dc		HART Protocol
	4-20mA dc none		DE Protocol Foundation Fieldbus
c. Customer Interface Selections	Indicator	Ext Zero, Span & Config Buttons	Languages
	None	None	None
	None	Yes (Zero/Span Only)	None
	Basic	None	EN
	Basic	Yes	EN

A __	*	*	√
B __	*	*	
C __	*	*	√
D __	*	*	
_ H _	*	*	√
_ D _	*	*	
_ F _	*	*	
_ _ 0	*	*	√
_ _ A	f	f	√
_ _ B	*	*	√
_ _ C	*	*	√

TABLE V CONFIGURATION SELECTIONS			
a. App S/W	Diagnostics		
	Standard Diagnostics		
b. Output Limit, Failsafe & Write Protect Settings	Write Protect	Fail Mode	High & Low Output Limits <sup>3</sup>
	Disabled	High> 21.0mAdc	Honeywell Std (3.8 - 20.8 mAdc)
	Disabled	Low< 3.6mAdc	Honeywell Std (3.8 - 20.8 mAdc)
	Enabled	High> 21.0mAdc	Honeywell Std (3.8 - 20.8 mAdc)
	Enabled	Low< 3.6mAdc	Honeywell Std (3.8 - 20.8 mAdc)
	Enabled	N/A	N/A Fieldbus
	Disabled	N/A	N/A Fieldbus
c. General Configuration	General Configuration		
	Factory Standard Customer Configuration (Unit Data Required)		

1 __	*	*	√
_ 1 _	f	f	√
_ 2 _	f	f	√
_ 3 _	f	f	√
_ 4 _	f	f	√
_ 5 _	g	g	√
_ 6 _	g	g	√
_ _ S	*	*	√
_ _ C	*	*	

<sup>2</sup> Left side/Right side as view ed from the customer connection perspective  
<sup>3</sup> NAMUR Output Limits 3.8 - 20.5mAdc can be configured by the custom

Section 13  
Page STA7-3  
Effective Date: Dec 30, 2012

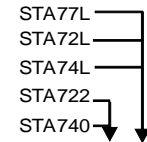

TABLE VI CALIBRATION & ACCURACY SELECTIONS			
a. Accuracy and Calibration	Accuracy	Calibrated Range	Calibration Qty
	Standard	Factory Std	Single Calibration
	Standard	Custom (Unit Data Required)	Single Calibration

A	*	*	✓
B	*	*	✓

TABLE VII ACCESSORY SELECTIONS		
a. Mounting Bracket	Bracket Type	Material
	None	None
	Angle Bracket	Carbon Steel
	Angle Bracket	304 SS
	Marine Approved Angle Bracket	304 SS
	Flat Bracket	Carbon Steel
	Flat Bracket	304 SS

0 ___	*	*	✓
1 ___	*	*	✓
2 ___	*	*	✓
4 ___	*	*	✓
5 ___	*	*	✓
6 ___	*	*	✓

b. Customer Tag	Customer Tag Type	
	No customer tag	
	One Wired Stainless Steel Tag (Up to 4 lines 26char/line) Two Wired Stainless Steel Tag (Up to 4 lines 26 char/line)	

_ 0 _ _	*	*	✓
_ 1 _ _	*	*	✓
_ 2 _ _	*	*	✓

c. Unassembled Conduit Plugs & Adapters	Unassembled Conduit Plugs & Adapters	
	No Conduit Plugs or Adapters Required	
	1/2 NPT Male to 3/4 NPT Female 316 SS Certified Conduit Adapter	
	1/2 NPT 316 SS Certified Conduit Plug	
	M20 316 SS Certified Conduit Plug	
	Minifast® 4 pin (1/2 NPT) (not suitable for X-Proof applications)	
	Minifast® 4 pin (M20) (not suitable for X-Proof applications)	

_ _ A0	*	*	✓
_ _ A2	n	n	✓
_ _ A6	n	n	✓
_ _ A7	m	m	
_ _ A8	n	n	
_ _ A9	m	m	

TABLE VIII	OTHER Certifications & Options: (String in sequence comma delimited (XX, XX, XX,...))
Certifications & Warranty	NACE MR0175; MR0103; ISO15156 (FC33338) Process wetted parts only
	NACE MR0175; MR0103; ISO15156 (FC33339) Process wetted and non-wetted parts
	Marine (DNV, ABS, BV, KR, LR) (FC33340)
	EN10204 Type 3.1 Material Traceability (FC33341)
	Certificate of Conformance (F3391)
	Calibration Test Report & Certificate of Conformance (F3399)
	Certificate of Origin (F0195)
	FMEDA (SIL 2/3) Certification (FC33337)
	Over-Pressure Leak Test Certificate (1.5X MAWP) (F3392)
	Cert Clean for O <sub>2</sub> or CL <sub>2</sub> service per ASTM G93

FG	c	c	b	✓
F7	c	c		✓
MT	d	d		✓
FX	*	*		✓
F3	*	*	b	✓
F1	*	*		✓
F5	*	*		✓
FE	j	j		✓
TP	*	*		
OX	e	e		

TABLE IX	Manufacturing Specials
Factory	Factory Identification

0 0 0 0	*	*
---------	---	---

RESTRICTIONS

Restriction Letter	Available Only with		Not Available with	
	Table	Selection(s)	Table	Selection(s)
a			VIII	FG, F7
c	Id	_ _ _ 0,N,K,D,B _ _	Ia	C, G, L, _ _ _ _ _
d			VIIa	1,2,5,6 _ _
e	lb	_ 2 _ _ _ _		
f			IV b	_ F _
g			IVb	_ H,D _
h			Ie	_ _ _ 4,5,6 _
			VIIa	1,2,4,5,6 _ _ _
j	IVb	_ H _	Vb	_ 1,2,6 _
m	IVa	B,D _ _		
n	IVa	AC _ _		
p			III	B - No CRN number available
r			VIII	F7, FG
			III	B - No CRN number available
t			1a	J, K, L _ _ _ _ _
b	Select Only one option from this group			

## Sales and Service

For application assistance, current specifications, pricing, or name of the nearest Authorized Distributor, contact one of the offices below.

### ASIA PACIFIC

(TAC)

[hfs-tac-support@honeywell.com](mailto:hfs-tac-support@honeywell.com)

#### Australia

Honeywell Limited  
Phone: +(61) 7-3846 1255  
FAX: +(61) 7-3840 6481  
Toll Free 1300-36-39-36  
Toll Free Fax:  
1300-36-04-70

#### China – PRC - Shanghai

Honeywell China Inc.  
Phone: (86-21) 5257-4568  
Fax: (86-21) 6237-2826

#### Singapore

Honeywell Pte Ltd.  
Phone: +(65) 6580 3278  
Fax: +(65) 6445-3033

#### South Korea

Honeywell Korea Co Ltd  
Phone: +(822) 799 6114  
Fax: +(822) 792 9015

### EMEA

Honeywell Process Solutions,  
Phone: + 80012026455 or +44  
(0)1202645583  
FAX: +44 (0) 1344 655554

Email: (Sales)

[sc-cp-apps-salespa62@honeywell.com](mailto:sc-cp-apps-salespa62@honeywell.com)

or

(TAC)  
[hfs-tac-support@honeywell.com](mailto:hfs-tac-support@honeywell.com)

### NORTH AMERICA

Honeywell Process Solutions,  
Phone: 1-800-423-9883  
Or 1-800-343-0228

Email: (Sales)

[ask-ssc@honeywell.com](mailto:ask-ssc@honeywell.com)

or

(TAC)  
[hfs-tac-support@honeywell.com](mailto:hfs-tac-support@honeywell.com)

### SOUTH AMERICA

Honeywell do Brasil & Cia  
Phone: +(55-11) 7266-1900  
FAX: +(55-11) 7266-1905

Email: (Sales)

[ask-ssc@honeywell.com](mailto:ask-ssc@honeywell.com)

or

(TAC)  
[hfs-tac-support@honeywell.com](mailto:hfs-tac-support@honeywell.com)

*Specifications are subject to change without notice.*



**For More Information**

Learn more about how Honeywell's SmartLine Smart Pressure Transmitters can increase performance, reduce downtime and decrease configuration costs, visit our website [www.honeywellprocess.com](http://www.honeywellprocess.com) or contact your Honeywell account manager.

**Honeywell Process Solutions**

1860 West Rose Garden Lane  
Phoenix, Arizona 85027  
Tel: 1-800-423-9883 or 1-800-343-0228  
[www.honeywellprocess.com](http://www.honeywellprocess.com)

**Honeywell**

34-ST-03-100  
February 2013  
© 2013 Honeywell International Inc.