

**ST 700 Series HART/DE Option
User's Manual**

**34-ST-25-47
Revision 1.0
February 2013**

Copyrights, Notices and Trademarks

© Copyright 2013 by Honeywell, Inc.

February 2013, Revision 1.0

While the information in this document is presented in good faith and believed to be accurate, Honeywell disclaims any implied warranties of merchantability and fitness for a particular purpose and makes no express warranties except as may be stated in the written agreement with and for its customers. In no event is Honeywell liable to anyone for any indirect, special, or consequential damages. The information and specifications in this document are subject to change without notice.

Honeywell, TDC 3000, SFC, SmartLine, PlantScape, Experion PKS, and TotalPlant are registered trademarks of Honeywell International Inc. Other brand or product names and service marks are the property of their respective owners.

**Honeywell Process Solutions
1860 Rose Garden Lane
Phoenix, AZ 85027**

About This Manual

This manual provides the details of programming Honeywell ST 700 SmartLine Pressure Transmitters for applications involving HART versions 5, 6, and 7 and Honeywell's Digitally Enhanced (DE) communication protocols. For installation, wiring, and maintenance information refer to the *ST 700 SmartLine Pressure Transmitter User Manual*, document number 34-ST-25-44.

The configuration of your Transmitter depends on the mode of operation and the options selected for it with respect to operating controls, displays and mechanical installation. Details for operations involving the Honeywell Multi-Communication (MC) Toolkit (MCT202) are provided only to the extent necessary to accomplish the tasks-at-hand. Refer to the associated MCT202 User Manual for complete details. The "Reference" section in the front matter of this manual lists document titles and numbers.

The ST 700 SmartLine Pressure transmitter can be digitally integrated with one of two systems:

- Experion PKS: you will need to supplement the information in this document with the data and procedures in the *Experion Knowledge Builder*.
- Honeywell's TotalPlant Solutions (TPS): you will need to supplement the information in this document with the data in the *PM/APM SmartLine Transmitter Integration Manual*, which is supplied with the TDC 3000 book set. (TPS is the evolution of the TDC 3000).

Release Information

ST 700 Series HART/DE Option User Manual, Document # 34-ST-25-47, Rev. 1.0, February 2013

References

The following list identifies publications that may contain information relevant to the information in this document.

SmartLine Pressure Transmitter Quick Start Installation Guide, Document # 34-ST-25-36

ST 800 & ST 700 SmartLine Pressure Transmitter w/ HART Comms Safety Manual, 34-ST-25-37

ST 700 SmartLine Pressure Transmitter User Manual, Document # 34-ST-25-44

ST 700 SmartLine FF Transmitter with FOUNDATION Fieldbus Option Installation & Device Reference Guide, Document # 34-ST-25-48

MC Toolkit User Manual, Document # 34-ST-25-20

PM/APM SmartLine Transmitter Integration Manual, Document # PM 12-410

ST 800 & ST 700 Series Pressure, Analog, HART and DE Communications form, Honeywell drawing 50049892.

Smart Field Communicator Model STS 103 Operating Guide, Document # 34-ST-11-14

Technical Bulletin, Communicating with Honeywell™ ST3000/STT3000 Smart Transmitters, Document #TB-960704B

MC Toolkit Modem Code Download Instruction Manual, Document # 34-ST-25-33

Patent Notice

The Honeywell ST 700 SmartLine Pressure Transmitter family is covered by one or more of the following U. S. Patents: 5,485,753; 5,811,690; 6,041,659; 6,055,633; 7,786,878; 8,073,098; and other patents pending.

Support and Contact Information

For Europe, Asia Pacific, North and South America contact details, refer to the appropriate Honeywell Solution Support web site:

Honeywell Corporate www.honeywellprocess.com

Honeywell Process Solutions www.honeywellprocess.com/pressure-transmitters/

Training Classes <http://www.automationcollege.com>

Telephone and Email Contacts

Area	Organization	Phone Number
United States and Canada	Honeywell Inc.	1-800-343-0228 Customer Service 1-800-423-9883 Global Technical Support
Global Email Support	Honeywell Process Solutions	ask-ssc@honeywell.com

Contents

1	ST 700 Physical and Functional Characteristics	1
1.1	Overview	1
1.2	Features and Options	1
1.2.1	Physical Characteristics	2
1.2.2	Functional Characteristics	3
1.3	Series, Model and Number	3
1.4	Safety Certification Information.....	3
1.5	Transmitter Adjustments	4
1.6	Local Display Options.....	4
1.7	Optional 3-Button Assembly.....	5
2	Communication Modes	6
2.1	Overview	6
2.2	Digitally Enhanced (DE) Mode Communication	6
2.3	HART Mode Communication	7
3	Configuration Tools and Interfaces	8
3.1	Overview	8
3.2	Pre-requisites	8
3.3	Application Design, Installation, Startup, and Operation.....	8
3.3.1	Organization	8
3.4	MC Toolkit Participation.....	9
3.4.1	MC Toolkit Software Applications	9
3.4.2	Configuration Databases	9
3.4.3	Configuration.....	9
3.4.4	MC Toolkit–Transmitter Electrical/Signal Connections	9
4	DE Transmitter Configuration.....	11
4.1	Configuration Personnel Requirements.....	11
4.2	MC Toolkit Software Application Overview	11
4.3	DE Transmitter Online Configuration.....	12
4.3.1	Uploading a Transmitter Configuration	12
4.3.2	Device Information Configuration	14
4.3.3	General Configuration Parameters	15
4.3.4	DE-Specific Configuration Parameters	16
4.3.5	Transmitter Display Configuration.....	18
4.3.6	Monitor Status Configuration.....	19
4.3.7	Saving the Configuration to File	20
4.3.8	DE Online Configuration Summary	21
4.4	DE Transmitter Offline Configuration	21
4.4.1	Overview	21
4.4.2	DE Offline File Management	21
4.4.3	Save to a File	22
4.4.4	Downloading in DE Offline Mode	22
4.4.5	DE Offline Parameterization.	22
5	HART Transmitter Configuration	23
5.1	Overview	23
5.1.1	Personnel Requirements	23

5.2	Overview of FDC Homepage	24
5.2.1	Settings.....	25
5.2.2	Manage DDs	26
5.2.3	Online configuration	27
5.2.4	Offline configuration.....	28
5.2.5	Online Configuration Overview.....	28
5.2.6	Overview of Device Homepage.....	28
5.2.7	Tabs on the Device Home page	29
5.2.8	Using FDC for various device operations.....	31
5.2.9	Device Configuration and Parameter Descriptions.....	33
5.2.10	Procedure to Enter the Transmitter Tag.....	44
5.2.11	Selecting the Process Variable (PV) Unit of Pressure Measurement.....	44
5.2.12	Setting PV URV, and LRV Range Values.....	45
5.2.13	Setting Range Values for Applied Pressure	45
5.2.14	Saving device history	46
5.2.15	Exporting device history records to FDM.....	47
5.2.16	Exporting device history records to Documint	48
5.2.17	Custom Views.....	48
5.2.18	Offline Configuration.....	50
6	DE Calibration	53
6.1	Overview.....	53
6.2	Calibration Recommendations	53
6.3	Test Equipment Required for Calibration	53
6.4	Analog Output Signal Calibration.....	53
6.5	Calibrating Range Using the MC Toolkit.....	55
6.6	Conditions for Input Calibration	55
6.7	Input Calibration Procedures Description.....	55
6.8	Input Calibration Procedure	56
6.8.1	Correct the Input at Zero	56
6.8.2	Correct Input at the Lower Range Value (LRV).....	58
6.8.3	Correct Input at URV.....	59
6.9	DE Output Calibration	60
6.9.1	Output Calibration Preparation	60
6.10	Manually Setting the Process Variable Range	62
6.11	Procedure to Reset Calibration	65
7	HART Calibration.....	67
7.1	About This Section	67
7.1.1	About Calibration.....	67
7.1.2	Equipment Required	67
7.2	Analog Output Signal Calibration.....	68
7.3	Calibrating Range	69
7.3.1	Correcting the Lower Range Value (LRV).....	69
7.3.2	Correcting the Upper Range Value (URV).....	69
7.3.3	Resetting Calibration.....	70
7.3.4	Calibration Records.....	70
8	HART Advanced Diagnostics.....	72
8.1	About This Section	72
8.2	Advanced Diagnostics.....	72
8.2.1	Install Date	72
8.2.2	PV Tracking Diagnostics	73
8.2.3	SV Tracking	75

8.2.4	TV Tracking Diagnostics	76
8.2.5	ET Tracking Diagnostics	76
8.2.6	% Stress Life.....	78
8.2.7	% Service Life	78
8.2.8	Operating Voltage Diagnostics.....	78
8.2.9	AVDD Tracking Diagnostics	79
8.2.10	Sensor CPU Temperature Tracking Diagnostics.....	79
8.2.11	Power Up Diagnostics	80
9	Troubleshooting and Maintenance	81
9.1	HART Diagnostic Messages	81
9.2	HART Diagnostic Details.....	82
9.3	DE Diagnostic Messages	86
10	Using DTMs	89
10.1	Introduction	89
10.2	Components.....	89
10.3	Downloads.....	89
10.4	Procedure to Install and Run the DTM.....	89
10.5	ST 700 Online Parameterization	90
10.5.1	Device Health:	91
10.5.2	Device Icon / Honeywell Logo:.....	91
10.5.3	Process Variables:	91
10.5.4	Shortcuts:.....	91
10.6	Basic Setup Page	92
10.6.1	Pressure Transfer Fn:.....	92
10.6.2	Low Flow Cutoff Mode:.....	92
10.6.3	Device Information.....	92
10.6.4	Model Number:	93
10.6.5	Device Assembly:.....	93
10.6.6	System Setup:	93
10.7	Calibration Page	94
10.7.1	Calibration Methods	94
10.7.2	Calibration Records	95
10.8	Process Variables.....	96
10.9	Trend Charts	97
10.10	Device Status	98
10.11	Critical and Non-Critical Help Display	99
10.12	Diagnostics:	100
10.13	Services	101
10.14	Detailed Setup	102
10.15	Meterbody Selection.....	103
10.16	Display Setup	103
10.17	Read Screen Info:	103
10.18	Screen Configuration:.....	103
10.19	Common setup:.....	103
10.20	Review	104
10.21	ST 700 Offline Parameterization.....	105
11	. HART DD binary file format compatibility matrix.....	106
	Glossary.....	107
	Sales and Service.....	1

List of Figures

Figure 1 – ST 700 Major Assemblies	2
Figure 2 – Electronics Housing Components	2
Figure 3 – Typical Atmospheric or Gauge Pressure Transmitter Name Plate Information	3
Figure 4 – DE Mode Value Scaling	6
Figure 5 – HART Point-to-Point and Multi-drop Value Scaling	7
Figure 6 – MC Toolkit-Transmitter Electrical/Signal Connections	10
Figure 7 – Differential Pressure Square Root Conformity Curve	17
Figure 8 – FDC Homepage	24
Figure 9 – Device Homepage	28
Figure 10 – Analog Output Calibration Test Setup	54
Figure 11 – Input Calibration Connections	56
Figure 12 – Output Calibration Test Connections	60
Figure 13 – DE Analog Mode Scaling and Test Connections	60
Figure 14 – Setup to Manually Set the PV LRV and URV	62

List of Tables

Table 1 – Features and Options	1
Table 2 – Available Display Characteristics	4
Table 3 – User Manual Related Topics	8
Table 4 – Device Information Parameters	14
Table 5 – General Configuration Parameters	15
Table 6 – DE Configuration Parameters	16
Table 7 – Local Display Configuration Parameters	18
Table 8 – Monitor Parameters	19
Table 9 - FDC homepage elements	24
Table 10 - Device health status	29
Table 11 – HART Transmitter Parameters	33
Table 12 – Tamper Reporting Logic Implementation with Write Protect	43
Table 13 – Calibration Records	71
Table 14 – Viewing Advanced Diagnostics	72
Table 15 – Maximum PV Tracking	73
Table 16 – Minimum PV Tracking	74
Table 17 – Maximum SV Tracking	75
Table 18 – Minimum SV Tracking	75
Table 19 – TV Tracking Diagnostics	76
Table 20 – Maximum ET Diagnostics	76
Table 21 – Minimum ET Diagnostics	77
Table 22 – Operating Voltage Diagnostics	78
Table 23 – Maximum and Minimum AVDD Tracking	79
Table 24 – Maximum Sensor CPU Temperature Tracking	79
Table 25 – Minimum Sensor CPU Temperature Tracking	79
Table 26 – Power Up Diagnostics	80
Table 27 – HART Diagnostic Messages	81
Table 28 – HART Critical and Non-Critical Diagnostic Details	82
Table 29 – DE Diagnostics	86

1 ST 700 Physical and Functional Characteristics

1.1 Overview

This section is an introduction to the physical and functional characteristics of Honeywell's family of ST 700 SmartLine Pressure Transmitters.

1.2 Features and Options

The ST 700 SmartLine Pressure Transmitter is available in a variety of models for measuring Differential Pressure (DP), Gauge Pressure (GP), and Absolute Pressure (AP). Table 1 lists the protocols, human interface (HMI), materials, approvals, and mounting bracket options for the ST 700.

Table 1 – Features and Options

Feature/Option	Standard/Available Options
Communication Protocols	HART, Digitally Enhanced (DE), Fieldbus
Human-Machine Interface (HMI) Options (Basic Display)	Basic Digital Display
	Three-button programming (optional)
	Basic display language: English only
Calibration	Single
Approvals (See Appendix C for details.)	ATEX, CSA, FM, IECx, NEPSI
Mounting Brackets	Angle/flat carbon steel/304 stainless steel, Marine 304 stainless steel
Integration Tools	Experion

1.2.1 Physical Characteristics

As shown in Figure 1, the ST 700 is packaged in two major assemblies: the Electronics Housing and the Meter Body. The elements in the Electronic Housing respond to setup commands and execute the software and protocol for the different pressure measurement types. Figure 2 shows the assemblies in the Electronics Housing with available options.

The Meter Body provides connection to a process system. Several physical interface configurations are available, as determined by the mounting and mechanical connections. Refer to the *ST 700 SmartLine User's Manual*, document number 34-ST-25-44 for installation and wiring details.

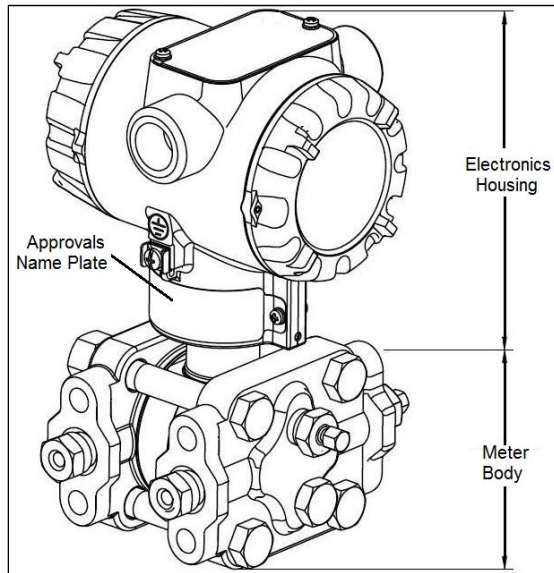

Figure 1 – ST 700 Major Assemblies

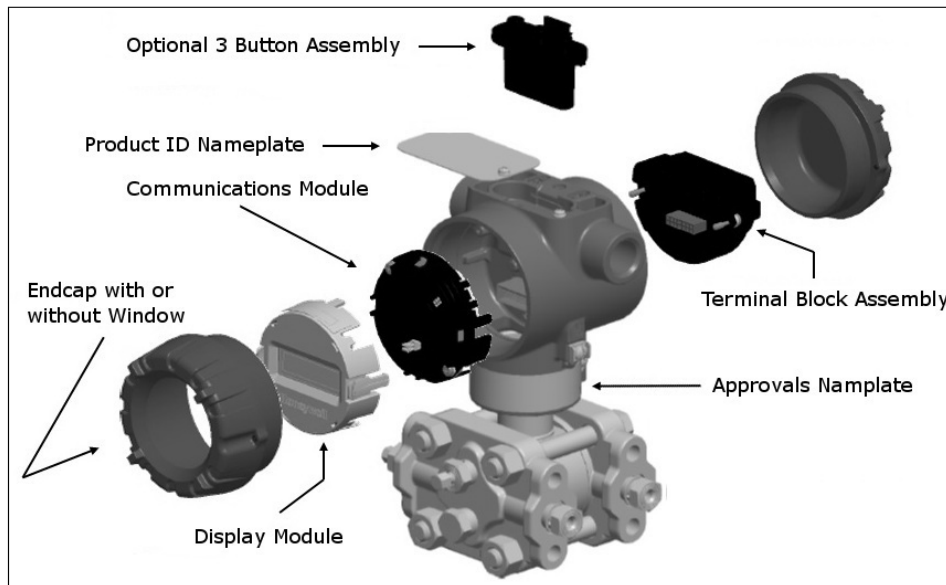

Figure 2 – Electronics Housing Components

1.2.2 Functional Characteristics

Functionally, the Transmitter measures process pressure and outputs a signal proportional to the measured process variable (PV). Available output communication protocols include analog 4 to 20 mA, Honeywell Digitally Enhanced (DE) protocol, HART, and FOUNDATION Fieldbus.

An optional 3-button assembly is available to set up and make adjustments to the Transmitter. In addition, a Honeywell Multi-Communication (MC) Toolkit (not supplied with the Transmitter) can facilitate setup and adjustment procedures. Certain adjustments can be made through an Experion Station or a Universal Station if the Transmitter is digitally integrated with Honeywell’s Experion or TPS/TDC 3000 control system.

1.3 Series, Model and Number

The Transmitter nameplate mounted on the top of the Electronics Housing (see Figure 2) lists the model number, physical configuration, electronics options, accessories, certifications, and manufacturing specialties. Figure 3 is an example of a typical Differential Pressure (DP) or Gauge Pressure (GP) or Atmospheric Pressure (AP) Transmitter name plate. The model number format consists of a Key Number with several table selections. The Differential Pressure (DP), Absolute Pressure (AP), and Gauge Pressure (GP) name plates are essentially the same. However, the DP provides one additional entry (7 vs. 6 characters) in the Meter Body Selections (Table I) to accommodate the static pressure rating.

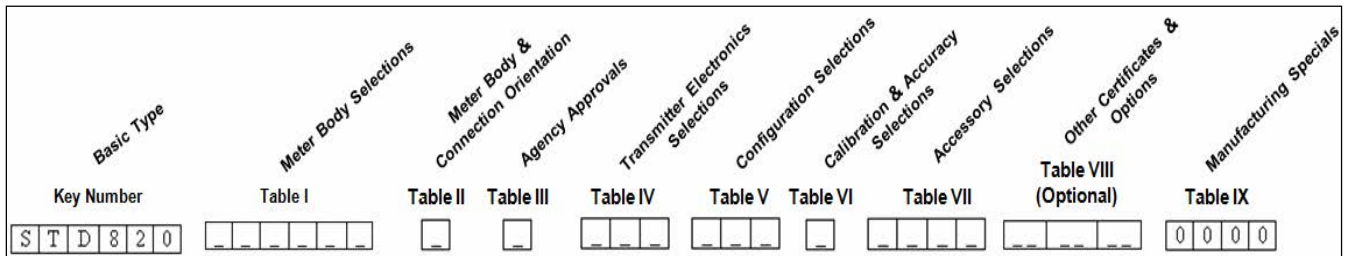

Figure 3 –Typical Atmospheric or Gauge Pressure Transmitter Name Plate Information

You can readily identify the series and basic Transmitter type from the third and fourth digits in the key number. The letter in the third digit represents one of these basic transmitter types:

- A = Absolute Pressure
- D = Differential Pressure
- F = Flange Mounted
- G = Gauge Pressure
- R = Remote Seals

For a complete selection breakdown, refer to the appropriate Specification and Model Selection Guide provided as a separate document.

1.4 Safety Certification Information

An “approvals” name plate is located on the bottom of the Electronics Assembly; see Figure 1 for exact location. The approvals name plate contains information and service marks that disclose the Transmitter compliance information. Refer to Appendix C of the *ST 700 SmartLine Transmitters User’s Manual*, document number 34-ST-25-44 for details.

1.5 Transmitter Adjustments

Zero and Span adjustments are possible in new generation ST 700 SmartLine Pressure Transmitters by using the optional three-button assembly located at the top of the Electronic Housing (see Figure 2). However, certain capabilities are limited in the following configurations:

- Without a display – Zero and Span setting only for HART and DE devices.
- With a display – Complete Transmitter configuration is possible for HART & DE devices.

You can also use the Honeywell MCT202 Configuration Tool to make any adjustments to an ST 700 Transmitter. The MCT202 tool has two applications; MC Toolkit and FDC. Using the MC Toolkit application you can adjust the ST 700 DE model configuration. Using the Field Device Configurator (FDC) application, you can adjust the ST 700 HART model configuration. Alternately, you can use the Honeywell SmartLine Configuration Tool, SCT 3000, for configuring DE models. Certain adjustments can also be made through the Experion or Universal Station if the Transmitter is digitally integrated with a Honeywell Experion or TPS system.

ST 700 HART models can be configured using Honeywell tools such as Experion in conjunction with FDM, using DTMs running in FDM or Pactware, or Emerson 375 or 475.

1.6 Local Display Options

The ST 700 Pressure Transmitter offers a basic display, see Table 2.

Table 2 – Available Display Characteristics

Basic Display	<ul style="list-style-type: none">• Suitable for basic process needs• 360° rotation in 90° Increments• 2 lines, 16 characters• Standard engineering units• Diagnostic messaging• Square root output indication• Supports optional 3-Button configuration and calibration
---------------	--

1.7 Optional 3-Button Assembly

The optional 3-button assembly provides the following features:

- Opportunity for immediate reaction with minimal disruptions
- Improved maintenance time
- Potential savings on hand-held units
- Suitable for all environments: hermetically sealed for long life in harsh environments
- Suitable for use in all electrical classifications (flameproof, dustproof, and intrinsically safe)

The 3-button assembly is externally accessible and provides the following capabilities:

- Menu-driven configuration with optional display:
 - Using increment, decrement & enter keys
 - A comprehensive on screen menu guides the way
 - Configure the transmitter
 - Configure the display
 - Set zero and span
- Zero and span settings without optional display

2 Communication Modes

2.1 Overview

The ST 700 SmartLine Pressure Transmitter can be configured for operation with Honeywell's Digitally Enhanced (DE) communication protocol, HART version 7, and Fieldbus communication. This manual addresses the processes to configure and calibrate a Transmitter for DE and HART communication. Refer to the *ST 700 SmartLine FF Transmitter with FOUNDATION Fieldbus Option Installation & Device Reference Guide*, document number 34-ST-25-48 for Fieldbus details.

2.2 Digitally Enhanced (DE) Mode Communication

 Although it is unnecessary to put a control loop in manual mode before communicating with a Transmitter operating in DE mode, caution is required if there is potential for error in identifying the operating mode.

In DE mode, the PV is available for monitoring and control purposes; and the meter body temperature (secondary variable) is available for monitoring purposes only.

Much of the operation in the Digitally Enhanced (DE) mode is similar to that of analog operation. The essential characteristics of DE mode operation are shown in Figure 4.

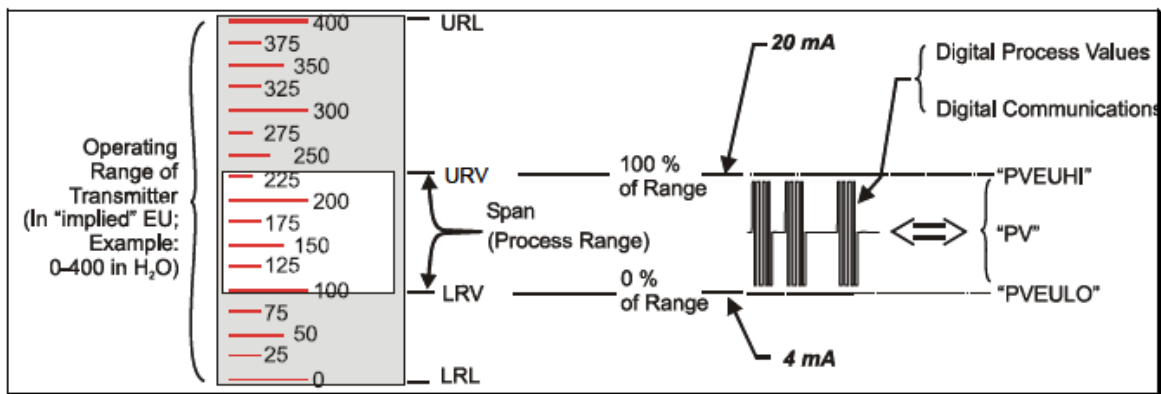

Figure 4 – DE Mode Value Scaling

As indicated at the right of Figure 4, output values of process variables, as well as communications are transferred to a receiving device digitally. The digital coding is Honeywell proprietary, which requires the use of DE-capable Honeywell control equipment.

The use of DE mode offers several advantages:

- **Process Safety.** Unlike analog mode, communications devices do not *bump* the PV value.
- **Accuracy:** requires less maintenance.
- **Digital communication:** Relatively immune to small variations in circuit resistance or supply voltage.
- **Facilitates Maintenance Tasks:** Honeywell control systems include operating displays that enable direct communication with transmitters operating in DE mode.

2.3 HART Mode Communication

! When using MCT202, before connecting to a HART transmitter, verify that the FDC application is used and not the MC Toolkit application. When you use the MC Toolkit application, the MCT202 is set for DE communications, where the current amplitude can *bump* process variables in either point-to-point or in the multi-drop mode in HART.

- Transmitters with HART capability have features that vary among manufacturers and with the characteristics of specific devices. The FDC software application executing on the MCT202 supports the HART Universal, Common Practice and Device Specific Commands which are implemented in the Honeywell Transmitters.

As indicated in Figure 5, the output of a Transmitter configured for HART protocol includes two primary modes:

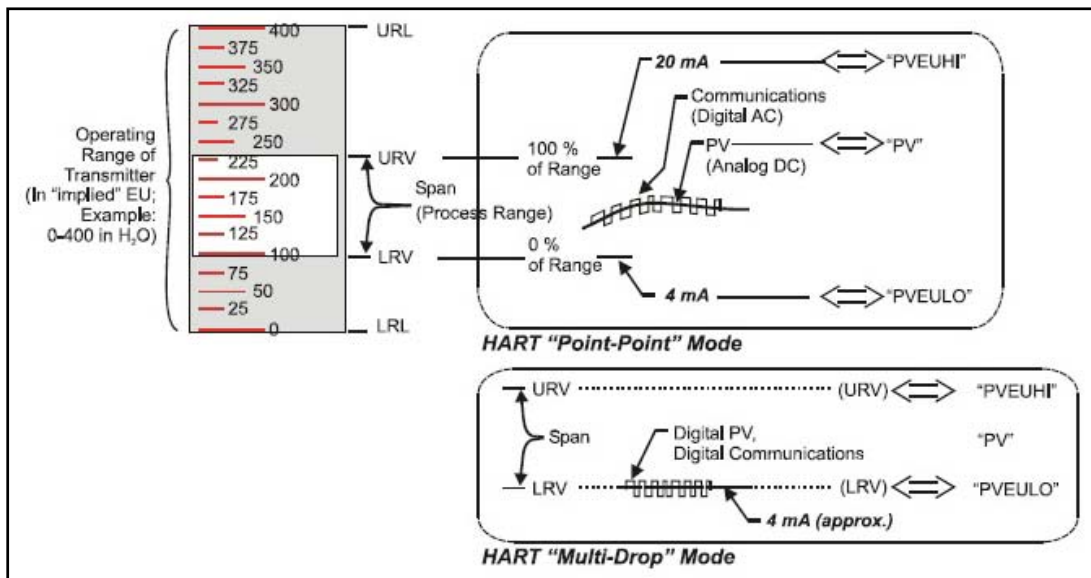

Figure 5 – HART Point-to-Point and Multi-drop Value Scaling

- Point-to-Point Mode, in which one Transmitter is connected via a two-conductor, 4-20 mA current loop to one receiver.
- Multi-Drop Mode, in which several Transmitters are connected through a two-conductor network to a multiplexed receiver device.

In point-to-point mode, the value of the primary Process Variable (PV) is represented by a 4-20 mA current loop, almost identical to that of a Transmitter operating in analog mode. In this case, however, the analog signal is modulated by Frequency Shift Keying (FSK), using frequencies and current amplitude that do not affect analog sensing at the receiver. The accuracy of the analog level must be precisely controlled for accurate sensing. HART communication will not *bump* process variables.

In multi-drop mode, up to 16 transmitters in HART 5 (addresses 0-15) and up to 64 transmitters in HART6/7 (addresses 0-63) can exist on the two-conductor network.

3 Configuration Tools and Interfaces

3.1 Overview

This section describes the tools and interfaces involved in configuring a new ST 700 SmartLine Pressure Transmitter for HART or DE communication operation. The information in this section also applies to adjusting the configuration of a Transmitter that has been in operation and updating one that is currently in operation.

3.2 Pre-requisites

The information and procedures in this manual are based on the assumption that personnel performing configuration and calibration tasks are fully qualified and knowledgeable in the use of the Honeywell MC Toolkit or MCT202. The name MC Toolkit or Toolkit and MCT202 are used interchangeably as MCT202 is the model name for the Honeywell MC Toolkit product. Furthermore, we assume that the reader is intimately familiar with the ST 700 family of SmartLine Pressure Transmitters and thoroughly experienced in the type of process application targeted for Transmitter deployment. Therefore, detailed procedures are supplied only in so far as necessary to ensure satisfactory completion of configuration tasks.

3.3 Application Design, Installation, Startup, and Operation

The *ST 700 SmartLine Pressure Transmitters User's Manual*, document number 34-ST-25-44, provides the details for application design, installation, and startup; see Table 3 for topics.

Table 3 – User Manual Related Topics

ST 700 SmartLine Pressure Transmitters Users Manual		
Section 2. Application Design	Section 3. Installation and Startup	Section 4. Operation
Safety and accuracy Diagnostics messages Design consideration	Site evaluation Toolkit issues Display installation concerns Transmitter mounting & zero-correction Piping & wiring Startup tasks and procedures	Three-button option Failsafe direction setup Monitoring displays

3.3.1 Organization

This information in this section is arranged in the following sequence:

- MC Toolkit participation in ST 700 Transmitter Setup and Configuration:
 - Physical circuit connections
 - Application components
 - Configuration for Analog, DE, and HART operation
- ST 700 Transmitter
 - Basic displays
 - Health indications
 - Ability to be configured and operate in a process system

3.4 MC Toolkit Participation



Before using the MC Toolkit, be sure that you are aware of the potential consequences of each procedure, and that you use appropriate safeguards to avoid possible problems. For example, if the Transmitter is an element in a control loop, the loop needs to be put in manual mode, and alarms and interlocks (i.e., trips) need to be disabled, as appropriate, before starting a procedure.

3.4.1 MC Toolkit Software Applications

The MC Toolkit has two software applications to work with ST 700 SmartLine Pressure Transmitters:

- **Field Device Configurator (FDC).** This application is used for configuring, calibrating, monitoring, and diagnosing HART devices. FDC conforms to the IEC 61804-3 EDDL (Electronic Data Description Language) standard specification. The FDC application is an open solution that supports devices with a registered device description (DD) file compatible with HART Communication Foundation (HCF) requirements.
- **MC Toolkit.** This application is used for configuring, calibrating, monitoring, and diagnosing Honeywell Digitally Enhanced (DE) devices.

Details for working with the MC Toolkit are provided in the *MC Toolkit User Manual*, document # 34-ST-25-20. In subsequent sections of this manual, explicit operating instructions are provided only in so far as necessary to complete required tasks and procedures.

3.4.2 Configuration Databases

The MC Toolkit is used to establish and/or change selected operating parameters in a Transmitter database.

3.4.3 Configuration

Configuration can be accomplished both online and offline with the Transmitter powered up and connected to the MC Toolkit. Online configuration immediately changes the Transmitter operating parameters. For offline configuration, Transmitter operating characteristics are entered into Toolkit memory for subsequent downloading to a Transmitter.



When you set up or configure a Transmitter, it can take up to 30 seconds for the value to be stored in it. If you change a value and Transmitter power is interrupted before the change is copied to nonvolatile memory, the changed value will not be moved to nonvolatile memory.

3.4.4 MC Toolkit–Transmitter Electrical/Signal Connections

Figure 6 displays how to connect the MC Toolkit directly to the terminals of a HART or DE Transmitter (top), and a HART-only Transmitter (bottom).

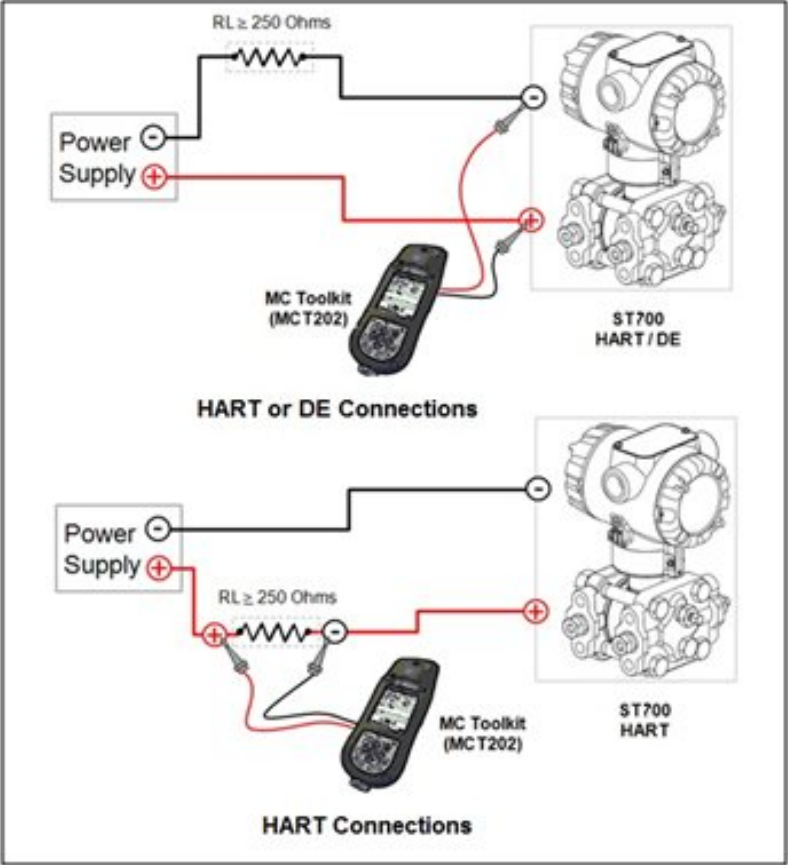

Figure 6 – MC Toolkit-Transmitter Electrical/Signal Connections

4 DE Transmitter Configuration

4.1 Configuration Personnel Requirements

The configuration processes in this section reflect the assumption that you will use the Honeywell MC Toolkit Configuration Tool to configure an ST 700 SmartLine Pressure Transmitter. The **MC Toolkit** application is used to configure Honeywell ST 3000 Pressure Transmitter, STT 3000 Smart Temperature Transmitters, as well as the ST 700 SmartLine Pressure Transmitter. Throughout, the term Transmitter means the ST 700 SmartLine Pressure Transmitter.

The other tools that support DE Transmitter configuration are the SmartLine Configuration Toolkit (SCT 3000), Experion PKS, and Smart Field Communicator (SFC).

4.2 MC Toolkit Software Application Overview

Each new ST 700 SmartLine Pressure Transmitter is shipped from the factory with a basic configuration installed. This basic configuration must be edited or revised to meet the requirements of your process system.

The **MC Toolkit** application supports both online and offline configuration.

- **Online** operation allows you to establish communication with a DE Transmitter for the following tasks:
 - Upload a Transmitter database.
 - Configure Transmitter parameters.
 - Calibrate a Transmitter.
 - Execute diagnostics.
 - Save a configuration to a file.

- **Offline** operation allows you to select a basic template, edit the parameters and download to a Transmitter after establishing communication with it. Parameter updates can also be saved in a file without actually downloading them to a Transmitter.

Specific operating details for the MC Toolkit displays are provided in Section 3.5, “MC Toolkit Application Software Display Conventions,” of the *MC Toolkit User Manual*, (document number 34-ST-25-20) for the following:

- Navigation
- The MC Toolkit Menu Bar
- File Menu
- Modem Menu
- Help Menu
- Data Entry and Display

4.3 DE Transmitter Online Configuration

Online configuration consists of establishing communication between the MC Toolkit and a Transmitter configured for DE communication. Each Transmitter has a configured database, whether new from the factory, a spare, or one to be reconfigured. In any case, the **MC Toolkit** application is used to upload the existing configuration from the Transmitter for review and editing.

4.3.1 Uploading a Transmitter Configuration

1. Connect a DE Transmitter to the MC Toolkit. Be sure that both devices have power applied.
2. Start the **MC Toolkit** application by selecting Start / MC Toolkit on the MC Toolkit / MCT202. The MC TOOLKIT Home page will be displayed.

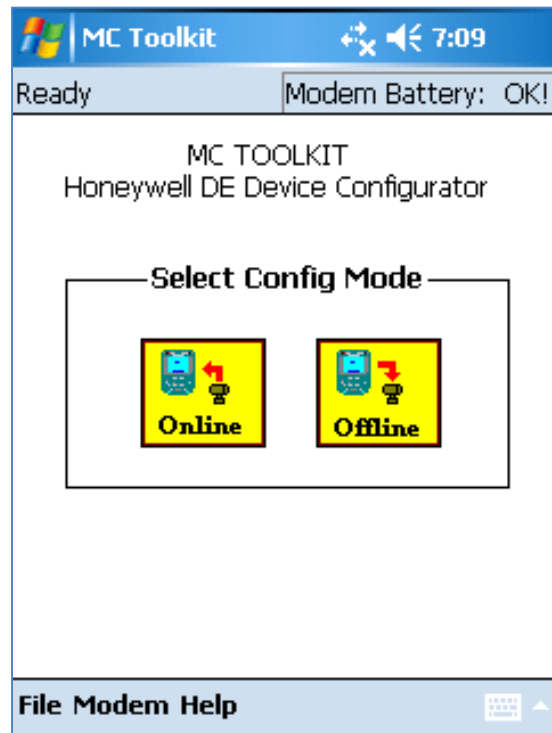

3. Select the **Online** button, and establish communication between the Toolkit and the Transmitter.
4. When the warning message for connecting to a DE device appears, select **OK**.
5. Process the three warning pop-ups as appropriate, and then select **OK** in the **Put loop in Manual...** pop-up. The QUICK MONITOR box will be displayed.

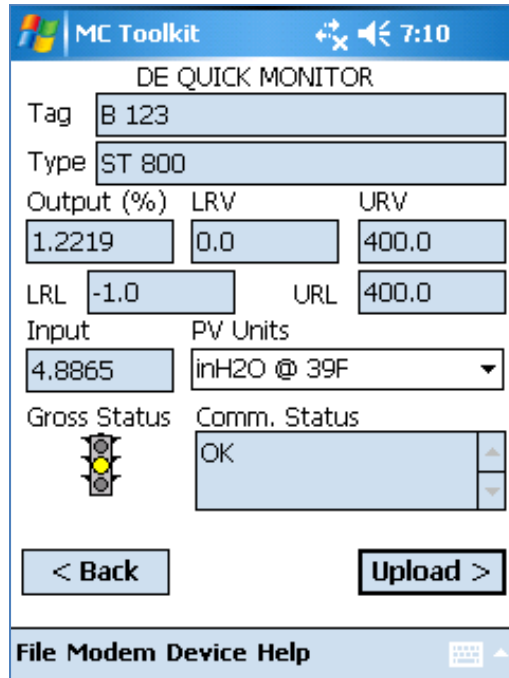

6. Select **Upload**. A progress bar will be displayed on the QUICK MONITOR box, and when the upload is complete, the DE MAIN MENU will be displayed.

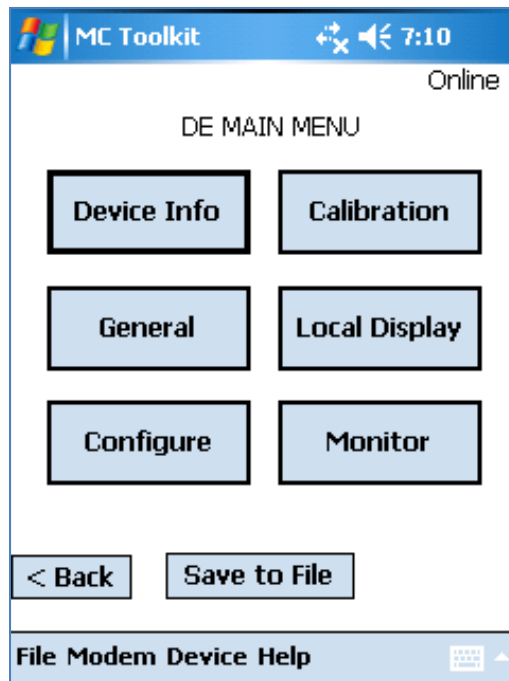

A confirmation request message will be displayed if you select **<Back** for a Transmitter that was previously set to Output Mode during calibration, and was not subsequently cleared. If you confirm the message (**Yes** answer), the display will exit the DE MAIN MENU.

4.3.2 Device Information Configuration

In this and subsequent procedures, the notations **R** for read only and **R/W** for read/write are used to indicate if a parameter can be edited.

1. On the DE MAIN MENU, select **Device Info**. The DEVICE INFO box will be displayed.



2. Configure device information according to Table 4.

Table 4 – Device Information Parameters

Parameter	Read (R) or Read/Write (R/W)	Configuration Details
Tag ID	R/W	User ID up to 8 alphanumeric characters.
Type	R	Manufacturer's device type identifier
Firmware Version	R	Manufacturer's firmware version identifier
PROM ID Number	R	PROM ID Number
Scratch Pad	R/W	Up to 32 alphanumeric characters

3. Select the Back button to go back to the DE MAIN MENU.

4.3.3 General Configuration Parameters

Select the General button on the DEVICE MAIN MENU page, and configure parameters according to Table 5.

The screenshot shows a configuration window titled "GENERAL". It contains three dropdown menus: "PV Type" is set to "Single Range", "Communication Mode" is set to "DE 6 Byte", and "Failsafe Direction" is set to "Upscale". At the bottom of the window are two buttons: "Send" and "Back".

Table 5 – General Configuration Parameters

Parameter	Read (R) or Read/Write (R/W)	Configuration Details
PV Type	R/W	Dual Range Smart Transmitter Digital Communications (STDC) or Single Range or Single Range with secondary variable (SV).
Communication Mode	R/W	Analog, DE 4-byte, or DE 6-byte
FS Direction	R	Failsafe (FS) direction: upscale or downscale, switch selectable on the electronics module. See the <i>ST 700 SmartLine Transmitter User Manual, 34-ST-25-44</i> for details.

Select the Back button to go back to the DE MAIN MENU.

4.3.4 DE-Specific Configuration Parameters

Select the **Configure** button, and configure parameters according to Table 6.

The screenshot shows a 'DE CONFIGURE' window with the following fields and values:

- LRL: 0.0
- URL: 400.0
- LRV: -0.021553
- URV: 224.42
- PV Units: inH2O @ 39F
- SV Units: °C
- Sensor Type: DP
- Damping: 0.48
- Span: 224.44
- Conformity: Linear

Buttons for 'Send' and 'Back' are visible at the bottom.

Table 6 – DE Configuration Parameters

Parameter	Read (R) or Read/Write (R/W)	Configuration Details
LRL	R	Lower Range Limit, Floating Point
URL	R	Upper Range Limit, Floating Point
LRV	R/W	Lower Range Value, Floating Point
URV	R/W	Upper Range Value, Floating Point
PV Units	R/W	Process Variable Units: scaling value selection; default = inches H ₂ O@39°F
SV Units	R/W	Secondary Variable scaling units: °C or °F
Sensor Type	R	Sensor type used in the Transmitter
Damping	R/W	Select digital noise reduction; (see note below)
Span	R	Process Range: URV – LRV, Floating Point
Conformity	R/W	Conformity: for the output calculation. Linear (pressure) or Square Root (flow); (see note below)

Select the Back button to go back to the DE MAIN MENU.

4.3.4.1 Notes on Damping (Digital Noise Reduction)

You can adjust the damping time to reduce output noise. By way of suggestion, set damping to the smallest value reasonable for your process.

The electrical noise effect on the output signal is partially related to the turndown ratio of the Transmitter. As the turndown ratio increases, the peak-to-peak noise on the output signal increases. You can use the following formula to find the turndown ratio using the range information for your Transmitter.

$$\text{Turndown Ratio} = \frac{\text{Upper Range Limit}}{(\text{Upper Range Value} - \text{Lower Range Value})}$$

Note that ST 700 Transmitters are specified with a minimum of 100:1 turndown capability.

4.3.4.2 Notes on Conformity

You can select the Transmitter output to represent a straight linear or a square root calculation for flow measurement applications with a differential pressure (DP) unit.

For a differential pressure (DP) Transmitter, measuring the pressure drop across a primary element, the flow rate is directly proportional to the square root of the pressure drop. The Transmitter output automatically converts to percent-of-flow when its output conformity is configured as square root.

You can use the following formulas to manually calculate the percent of flow for comparison purposes:

$$\frac{\Delta P}{\text{Span}} \times 100 = \%P$$

Where ΔP = Differential pressure input in engineering units
 Span = Transmitter measurement span (URV- LRV)
 %P = Pressure in percent of span

Therefore: $\sqrt{\frac{\%P}{100}} \times 100 = \% \text{ Flow}$

Also, you can use the following formula to determine the corresponding current output in Milliampere DC.

$$(\% \text{ Flow} \times 16) + 4 = \text{mA DC Output}$$

To avoid unstable output at readings near zero, the ST 700 Transmitter automatically drops square root conformity and changes to linear conformity for low differential pressure readings. As shown in Figure 7, the dropout point is between 0.4% and 0.5% of differential pressure, depending on direction

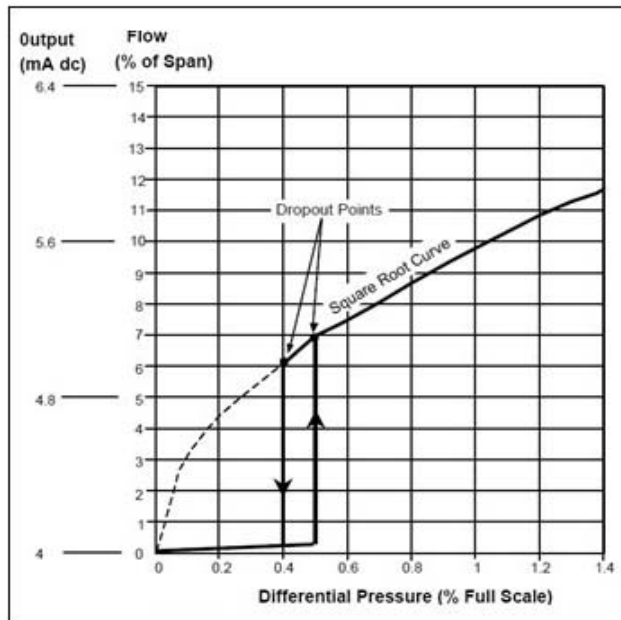
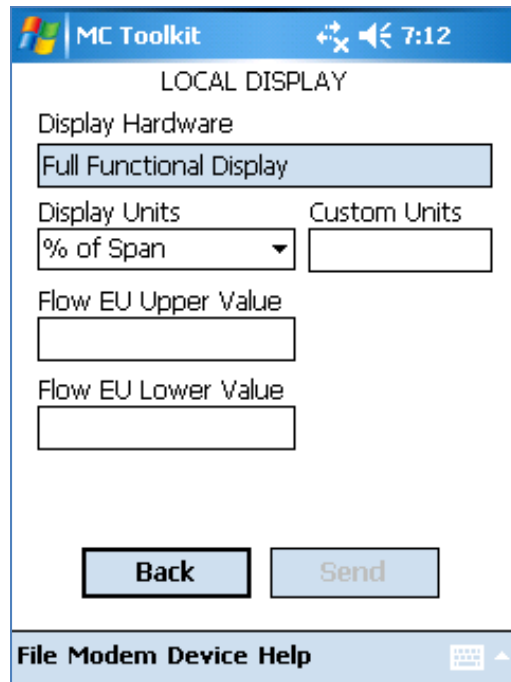

Figure 7 – Differential Pressure Square Root Conformity Curve

4.3.5 Transmitter Display Configuration

From the DE MAIN MENU, select the **Local Display** button. The LOCAL DISPLAY box will be displayed.



Select display parameters from the options listed in Table 7

Table 7 – Local Display Configuration Parameters

Parameter	Read (R) or Read/Write (R/W)	Configuration Details
Display Hardware	R	Type of Transmitter Display: <ul style="list-style-type: none"> Full Functional Display No Display installed
Display Units	R/W	Engineering Units for this Display: %, inH2O@39°F mmHg@0°C psi, KPa MPa, mBar, Bar g/cm2, kg/cm2 mmH2O@4°C mHg@0°C mH2O@4°C GPM GPH Custom
Custom Units Tag	R/W	8 Characters Note that the Custom Units Tag is not sent to the Display. It will be displayed in the Tool.
Flow EU Upper Value	R/W	Floating point (for square root configurations)
Flow EU Lower Value	R/W	Floating point (for square root configurations)

Select the Back button to go back to the DE MAIN MENU.

4.3.6 Monitor Status Configuration

With the DE MAIN MENU displayed, select the **Monitor** button. The MONITOR box will be displayed.

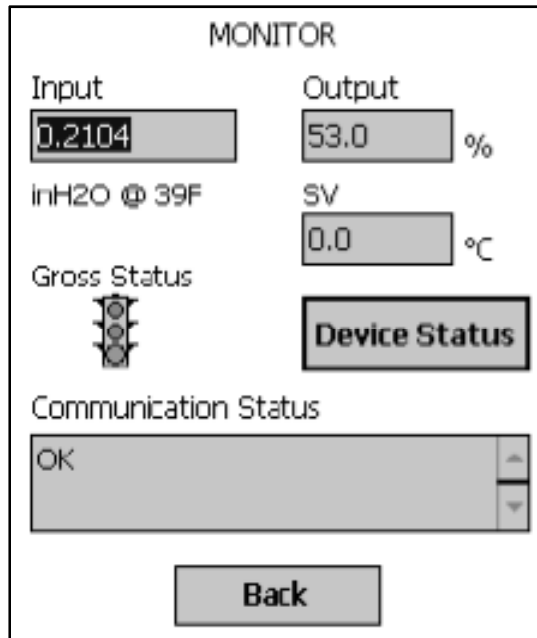

MONITOR status parameters are **R** (read only); Table 8 lists the status parameters.

Table 8 – Monitor Parameters

Parameter	Read (R) or Read/Write (R/W)	Configuration Details
Input	R	Sensor input in EU
Output	R	Loop output as a percent of Span
SV	R	Secondary Variable in SV EU
Gross Status	R	Gross Transmitter Status. Select the Monitor menu Device Status button to display device status.
Communication Status	R	Refer to the “Messages and Diagnostic Codes” section of the <i>MCT202 Toolkit</i> manual.

Select the Back button to go back to the DE MAIN MENU.

4.3.7 Saving the Configuration to File

1. Display the DE MAIN MENU, and select the **Save to File** button. The File Dialog will be displayed.

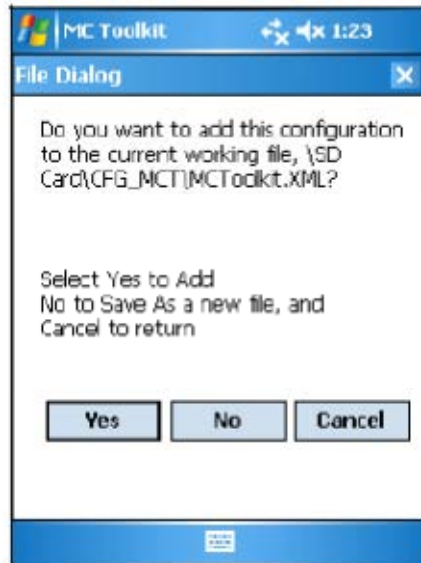

2. Save the configuration as follows:
 - a. Select **Cancel** to return to the DE MAIN MENU, and abort saving the configuration.
 - b. Select **Yes** to add the configuration to the current working file, and return the display to the DE MAIN MENU.
 - c. Select **No** to save to a different file; the Save As screen will be displayed.

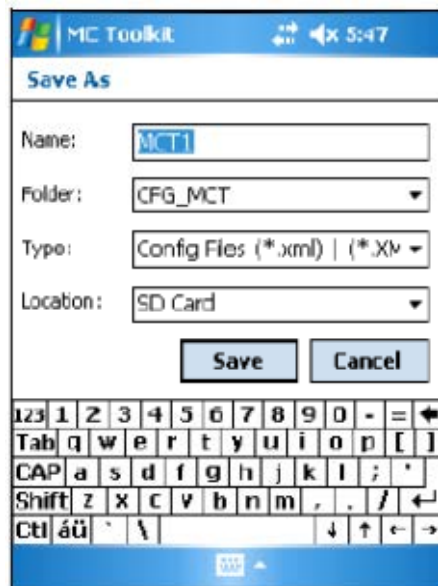

- d. The default location and folder are set to **SD Card** and **CFG_MCT**. However, you can type in a new name for the file; the default name is **New1**.
- e. After entering the file name, select the **Save** button to display the DE MAIN MENU.

4.3.8 DE Online Configuration Summary

This concludes the process of configuring an ST 700 DE transmitter online. For best operational results, calibrate the Transmitter according to Section 6, “Calibration” in this document.

4.4 DE Transmitter Offline Configuration

4.4.1 Overview

This section summarizes the features, capabilities, and processes for configuring an ST 700 SmartLine Pressure Transmitter set for DE operation offline. Refer to the *MC Toolkit User Manual*, 34-ST-25-20, section 5.6, “Offline Configuration” for complete procedural details.

After starting the **MC Toolkit** application, selecting the **Offline** button provides access to the following configuration features:

- **DE Offline File Management** – Open an XML file, select a saved configuration for the selected device and edit the parameters.
- **Save to File** – Save the parameters back to the file.
- **Download** – Download the current offline configuration to a device after establishing connection.

The MC Toolkit can process more than one device type or model. For the purposes of this section, the term *device* refers to the ST 700 SmartLine Pressure Transmitter, and/or one of its model variants.

4.4.2 DE Offline File Management

Offline configuration allows you to select a basic template, edit its parameter content, and download it to a Transmitter after establishing communication. Parameter updates can also be saved in a file without actually downloading to a Transmitter.

The MCT202 Toolkit is shipped with the two files: **MCToolkit.xml** and **TEMPLMCT.xml**:

- The **MCToolkit.xml** file consists of default configurations for all the supported DE devices. The available configurations can be updated and saved back to this file.
- The **TEMPLMCT.XML** is a template file. The contents of this template file **cannot** be edited; however, the template can be saved under a different file name. The contents of the newly named file can be edited.

DE offline file management provides general, configuration, and parameter options. General options provide for communication serial port selection of COM1 through COM8. However, the current configuration of the Toolkit Pocket PC (PPC) provides only COM1; the other seven serial port designations are reserved for future expansion.

Offline configuration options provide for confirmation before saving a changed configuration file. Denying confirmation results in having the changes discarded.

In addition to file saving confirmation, DE offline file management provides access to three parameter sets for review and editing:

- **Parameter Set 1** consists of the description of Transmitter according to bus type, device type, serial and model number, and the manufacturer.

- **Parameter Set 2** permits entering/editing the values for the LRL, URL, LRV, URV, PV Units, Damping, SV Units, Line Filter frequency, Sensor Type, and the Conformity selection.
- **Parameter Set 3** is oriented primarily to the Honeywell SmartLine Temperature Transmitter models for monitoring purposes.

4.4.3 Save to a File

Saving to a file in offline mode will let you add an edited configuration to a working file. Alternately, if you decide not to save an edited configuration to the current file, you can select a new location and file name for it. The default location and folder for saving configurations are **SD Card** and **CFG MCT**. The default name of a new configuration is **New1**, which you can change for your needs.

4.4.4 Downloading in DE Offline Mode

Downloading a file to a Transmitter from the Toolkit requires a communicating connection between the two units. Serial communication is established when you select **DOWNLOAD to Device** from the Toolkit **Select Device** menu. When the download completes, confirmation will be required to affirm that the configuration for the Transmitter is to be saved.

4.4.5 DE Offline Parameterization.

A table in Section 6, “Offline Configuration,” of the *MC Toolkit User Manual, 34-ST-25-80* contains a list of the basic ST 700 SmartLine Pressure Transmitter parameters for DE operation.

5 HART Transmitter Configuration

5.1 Overview

Each new ST 700 Pressure Transmitter configured for HART protocol is shipped from the factory with a basic configuration database installed. This basic configuration database must be edited or revised to meet the requirements of your process system. The process in this section assumes that you will use the **Field Device Communicator (FDC)** application for HART configuration tasks. The **FDC** application provides the facilities for the online and offline configuration of Transmitters operating with HART protocol

Online configuration requires that the Transmitter and MC Toolkit are connected and communication between the two has been established. Online configuration provides a set of functions with which to perform various operations on a HART communication network through an active communication link. These operations primarily include configuration, calibration, monitoring, and diagnostics. Typically, these operations could be realized through various constructs exposed by the Device Description (DD) file. In addition, the **FDC** application provides some functions for convenient execution of these functions.

Offline Configuration refers to configuring a device when the device is not physically present or communicating with the application. This process enables you to create and save a configuration for a device, even when the device is not there physically. Later when the device becomes available with live communication, the same configuration can be downloaded to the device. This feature enables you to save on device commissioning time and even helps you to replicate the configuration in multiplicity of devices with lesser efforts. Currently, FDC does not support creating offline configuration. However, it supports importing of offline configuration from FDM R310 or later versions. The configurations thus imported can be downloaded to the device from FDC. The following are the tasks that you need to perform for importing offline configuration in FDC application software and then downloading it to the device.

- Create offline configuration template in FDM
- Save the configuration in FDM in FDM format.
- Import the offline configuration in FDC
- Download the offline configuration to the device

Note: For details on creating and using offline configuration, refer to section Offline configuration in FDM User's Guide.

5.1.1 Personnel Requirements

The information and procedures in this section are based on the assumption that the person accomplishing configuration tasks is fully qualified and knowledgeable on the use of the MC Toolkit and is intimately familiar with the ST 700 family of SmartLine Pressure Transmitters. Therefore, detailed procedures are supplied only in so far as necessary to ensure satisfactory configuration. The other HART configuration Tools are Honeywell Experion in conjunction with FDM, iDTMs running on FDM or Pactware, and Emerson 375/475. The organization of Device Configuration and Parameter Descriptions on page 33 is given in Table 11.

5.2 Overview of FDC Homepage

The FDC homepage consists of links for Online Configuration, Offline Configuration, Manage DDs, and Settings. See below.

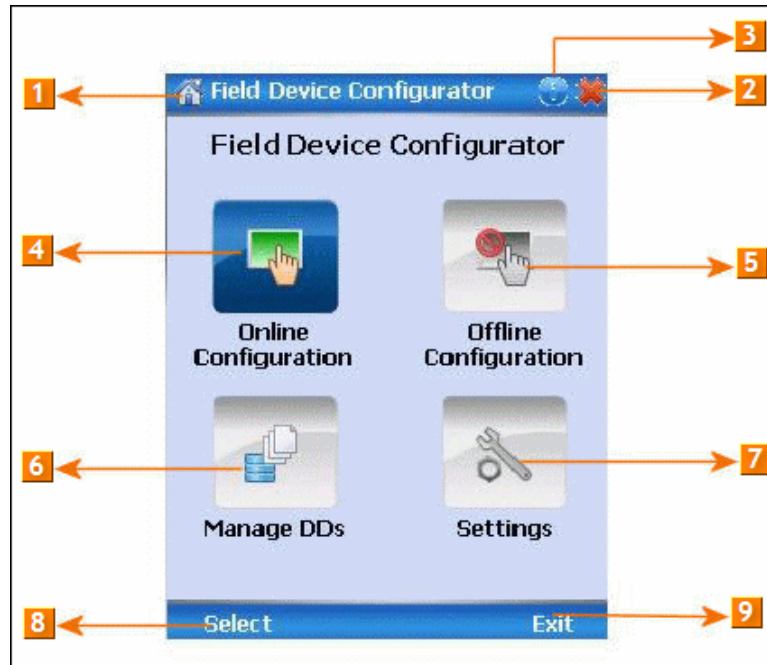

Figure 8 – FDC Homepage

Table 9 lists the items that appear on the FDC homepage and its descriptions.

Table 9 - FDC homepage elements

Items	Description
1	Screen title.
2	Tap to quit FDC.
3	Tap to view the application information.
4	Tap to navigate to Online Configuration screen.
5	Tap to navigate to Offline configuration screen.
6	Tap to navigate to Manage DDs screen.
7	Tap to navigate to Settings screen.
8	Tap to select the highlighted menu option.
9	Tap to quit FDC.

Note: To select a particular option in FDC you can either select the option and then tap **Select** or you can directly double-tap the option.

5.2.1 Settings

Use this feature to customize FDC. You can customize FDC for device detection, DD selection, and other application settings.

5.2.1.1 Device Identification

Use the following options to configure FDC to identify a device.

- **Using Poll Address**
 - **Use poll address 0 only:** Use this to detect a device with the poll address as zero.
 - **Find first poll address and use:** Use this to detect a device with the first available poll address in the range of poll addresses that are available.
 - **Use selected poll address:** Use this to detect a device with a specific poll address in the range of zero to 63.
 - **Use From:** Use this to detect a device based on a range of poll addresses.
- **Using Device TAG:** Use this to detect a device with a known HART tag.
- **Using Device LONG TAG:** Use this to detect a device with a known HART long tag (applicable for devices with HART 6 or later Universal revisions).

Note: If you choose the option Using Device TAG or Using Device LONG TAG, FDC prompts you to enter a device tag/long tag name during device detection.

5.2.1.2 DD selection

Use the following options to configure FDC to select DD files when a DD with matching device revision is not available.

- **Use DD file of previous device revision:** Use this option to automatically communicate using a DD file having device revision lower than that of the device.
- **Use generic DD file:** Use this option to automatically communicate to the device using an appropriate generic DD file.
- **Always ask user:** Use this option to always prompt you with a choice for communicating to the device either using the previous device revision or using a generic DD file.
- **Always Use Generic:** Use this option to always communicate to the device using generic DD files even if a DD file with matching device revision as the device is present.

Note: A generic DD file is a DD file that provides access and interface to the universal data and features of a HART device.

5.2.1.3 Other settings

Low storage notification: Use this option to set a percentage value and to notify you with a warning message when the available storage card space is less than the percentage set.

Application diagnostics: Use this option to enable or disable the logging infrastructure for application diagnostics. With this option enabled, FDC creates necessary log files for troubleshooting and diagnostics. These files are stored in SD Card\FDC folder.

Note: You must not enable this option unless suggested by Honeywell TAC because this may impact the application performance.

5.2.2 Manage DDs

Using this feature, you can manage the DD files installed with FDC. A DD file contains descriptive information about the functionality of a device. By default, a set of DD files are installed with FDC. However, if you do not have a DD for a given device, you can install it using the “Add DD” feature. Similarly, you can uninstall a DD file or a set of DD files using “Delete DD” feature. You can also directly copy the DD files in appropriate hierarchy using a card reader or “Active Sync/Mobile Device Center” mechanisms. In such a case, you should validate the library view using the “Refresh” feature.

5.2.2.1 Overview

Using Manage DDs, you can view, add, or delete DD files for devices. A list of already available DD files is maintained in the DD Library. FDC lists the installed DD files in a hierarchy as below:

Manufacturer
Device Type
DevRev xx, DDRRev yy
DevRev pp, DDRRev qq

5.2.2.2 Add a DD file

To add a DD file for a device, perform the following steps.

1. From the FDC homepage, tap Manage DDs > Select.
The **Manage DDs** dialog box appears.

2. Tap **Options** > **Add DD**.

Or

Tap .

The **ADD DD files** dialog box appears.

3. Browse to the location in which the DD file (**.fm8**) is located and tap **OK**.
4. If the DD file already exists, then the following message appears.

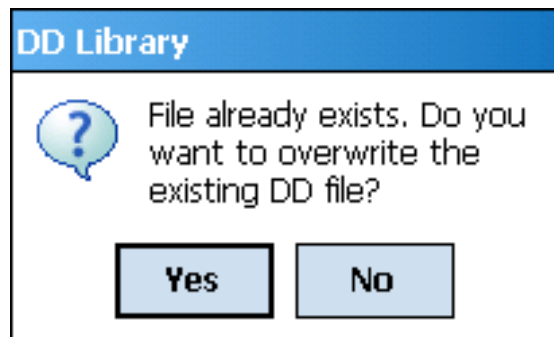

5. Tap **Yes** to overwrite the existing DD files.
6. If the DD file is added successfully, a success message appears.

5.2.2.3 Delete a DD file

Using this option, you can delete a particular version of a DD file. To delete a DD file for a device, perform the following steps.

1. From the FDC homepage, tap **Manage DDs > Select**.

The **Manage DDs** dialog box appears.

2. You can choose to delete DD(s) in one of the following ways:
 - a) By device manufacturer – Select a device manufacturer to delete all device types and DDs associated with the manufacturer’s devices.
 - b) By device type – Select a device type to delete all DDs associated with the device.
 - c) By device revision and DD revision – Select the specific entry of device revision, DD revision to delete the specific DD
3. Tap **Options > Delete DD**.

Or

Tap .

A confirmation message appears.

4. Tap **Yes**.

If the DD file is deleted successfully, a success message appears.

5. Tap **OK** to return to **DD Library** page.

5.2.2.4 Validating a manually edited library

Besides using the Add/Delete DD features, advanced users may also manipulate a DD library by directly editing the contents of the FDC\Library folder. DD files can also be transferred directly to this location by accessing the SD Card on MCT101 through a card reader and/or by connecting the MCT101 or MCT202 to a PC. In such cases, you must perform the following steps to validate a DD Library, thus edited manually:

1. From the **FDC homepage**, tap **Manage DDs > Select**

The **Manage DDs** dialog box appears

2. Tap **Options**.
3. Tap **Refresh Library**.

Or

Tap .

A confirmation message appears.

4. Tap **Yes**. The DD library is now validated and refreshed.

5.2.3 Online configuration

Using online configuration, you can configure, calibrate, monitor and diagnose a HART device which is connected to MC Toolkit. FDC provides the features to perform these functions through the various constructs offered through the DD file of the device. Besides there are certain other features available under this link for you to conveniently work with a HART device with live communication. After making changes to the device you can also save a snapshot of the device data as history to later transfer it to FDM for record and audit purposes.

5.2.4 Offline configuration

Offline configuration refers to configuring a device offline (without physically connecting to the device) using a template and then downloading the configuration to the device. Presently, FDC application software does not support creating offline configuration. However, it supports importing of offline configuration from FDM (R310 and above).

5.2.5 Online Configuration Overview

Online Configuration option provides you a set of functions with which you can perform various operations on a device with an active communication link. These operations primarily include configuration, calibration, monitoring, and diagnostics of a HART device. Typically, these operations could be realized through various constructs exposed by the DD file of the device. In addition, FDC also provides some additional application functions for you to perform these functions more conveniently.

Online configuration includes a set of functions to perform various operations on a Transmitter with active communication link. These operations primarily include:

- Identifying a Transmitter
- Reading and reviewing Transmitter variable values
- Editing Transmitter variable values
- Downloading the selected/edited variable set to the Transmitter

5.2.5.1 Detecting and loading a device

Tap the **Online Configuration** button on the **Application Home** page.

The device detection and loading process automatically gets started. Depending upon the Device Detection and DD Selection settings you may have chosen, you may be prompted for certain inputs as described in the **Settings** section.

5.2.6 Overview of Device Homepage



Once the device is detected and loaded successfully, you can view the device homepage for the identified device. The workspace area on the device homepage consists of 4 tabs on the left hand side. Selecting a tab displays functions/information associated with that tab on the right hand side.



Figure 9 – Device Homepage

Table 10 lists the device health status and their indications.

Table 10 - Device health status

Device health icons	Indications
	Indicates there's no health or status indicators reported by the device
	Indicates that the device is potentially reporting a status which needs attention and further investigation. It is advised that you use Device Status under Functions tab to further investigate the details.
	Indicates that the device has lost communication with MC Toolkit

5.2.7 Tabs on the Device Home page

The following are the options that are available on the device homepage

Information tab: Use this option to view the device identity related information. You can view the manufacturer name, device type, device revision, DD revision, and universal revision of the HART device.



- **Functions tab:** This tab provides various options which you may use for navigating through the device specific user interface and some standard features offered by FDC across all devices. For the sake of explanations, the right side options under this tab shall be referred as “Entry points” throughout the rest of the document.



- My Views tab:** Quite often, you may be interested only in a set of variables of a device. But navigating through the menu tree of a device may not be helpful because of time and further all variables that you want may not be in the same location. Using this unique feature of FDC, you can now choose what you want to view in a device in your own views. FDC allows you to create two such views per device revision of a specific device type. You can always modify them as per your needs.



- Tools tab:** This tab is a placeholder for FDC specific tools for providing certain functionality. Currently the only option it provides is called as Save History. Using this option you can save the snapshot of the device variables. This snapshot is saved in a format which can be later imported as a history record in FDM.



5.2.8 Using FDC for various device operations

Typical operations with a smart field device involve configuration, calibration, monitoring, and diagnostics. FDC enables you to achieve these operations with a HART device via the various interfaces/constructs exposed through the DD file of the device.

The “Functions” tab under the device home page provides the entry points for navigating through the device specific user interface to perform the above mentioned operations. A device may define up to four entry points in the DD file. All devices shall have at least one entry point, generally referred to as “Online”. Besides the device specific entry points, FDC provides custom entry points for navigational aids to specific types of information/features. One such entry point is called Device Status, which is used for reviewing device health. Another is called Methods List, which is used to navigate to all the methods available in a device.

All of the device specific entry points represent the device interface, as explained using the Online entry point as an example. All the other device specific entry points have a similar interface except for the fact that the variables and other DD constructs provided under each may vary as indicated by the title of each entry point.

 For the sake of explanation, the pages that appear on navigating through the device specific entry points are referred to as “Device Configuration” pages in this document. However it must be noted that this does not prohibit you from performing other device operations as explained above.

Online Device Entry Point: When you tap on to open the Online tab, the device configuration screen appears as shown below.

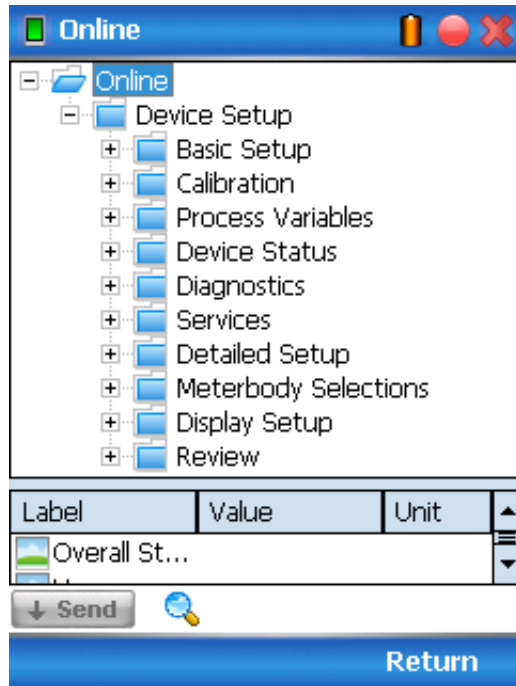

Alternately you can access the full EDDL features by selecting the “My Device” Tab

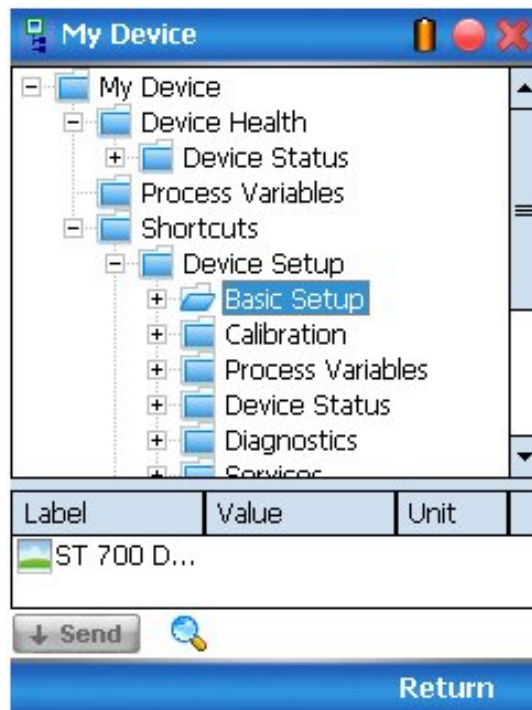

Navigate through the Menus to access various functions. See Table 11 for lists all the parameters in the ST 700.

5.2.9 Device Configuration and Parameter Descriptions

Table 11 lists descriptions of all parameters for a HART Transmitter with the Online tab menu path. The same parameters may be accessed via the Shortcuts menu under the My Device tab.

Table 11 – HART Transmitter Parameters

Online Menu Flow	Parameter menu/ name	Description/Valid values
Online/Overall Status		Displays a pictorial representation of the current device status
Online/Honeywell Logo		Photograph of an ST 700 Pressure Transmitter along with the official “Honeywell” logo
Online/PV Meter		Displays a gauge meter representation of the current value of the Primary Variable (pressure input)
Online/PV		Displays the current value of the Primary Variable (pressure input) in user selected engineering units
Online/SV Meter		Displays a gauge meter representation of the current value of the Secondary Variable (meter body temperature)
Online/SV		Displays the current value of the Secondary Variable (meter body temperature) in user selected engineering units
Online/AO Meter		Displays a gauge meter representation of the current value of the Analog Output
Online/PV AO		Displays the current value of Analog Output in mA
Online/TV		Displays the current value of the Tertiary Variable (static pressure) in psi
Online/PV % rnge		Displays the current value of transmitter Output in %
Online/PV LRV		Displays the current value of the Lower Range Value (input which represents 0% output) in user selected engineering units.. This value may be configured to any value within the range LTL to UTL.
Online/PV URV		Displays the current value of the Upper Range Value (input which represents 100% output) in user selected engineering units. This value may be configured to any value within the range LTL to UTL.
Online/ PV LRL		Displays the Lower Range Limit of the transmitter in user selected engineering units.
Online/ PV URL		Displays the Upper Range Limit of the transmitter in user selected engineering units.
Online/ PV LTL		Displays the Lower Transducer Limit of the transmitter in user selected engineering units.
Online/ PV UTL		Displays the Upper Transducer Limit of the transmitter in user selected engineering units.

Online/Device Setup/Basic Setup/ Pressure Xfer Fn	PV Xfer fnctn	Pressure Transfer function: Select the pressure transfer function for calculated output: Linear: (output scaled linearly per configured range) Square Root : (output scaled as square root conversion per configured range - for flow measurements)
	Transfer Function Image	Diagram of a flow application (square root transfer function) to exemplify dual-slope low-flow cutoff behavior with uni-directional flow
Online/Device Setup/Basic Setup/ Low flow Cutoff (Sq Root)	Low Flow Cutoff Mode	For Square Root (Transfer function) configurations only, choose the operating mode to determine the low flow cutoff breakpoint: Dual slope: (breakpoint determined by dual slope calculation) User configuration: (breakpoint defined by user)
	Low Flow Cutoff Breakpoint	When “User Configuration” is selected for Low Flow Cutoff Mode, enter the desired breakpoint value.
Online/Device Setup/Basic Setup/ ST 700 Device		Photograph of an ST 700 Pressure Transmitter
Online/Device Setup/Basic Setup/ System Connections		Diagram representing typical connections for power and communications for the ST 700 Pressure Transmitter
Online/Device Setup/Basic Setup/ ST 700 Assembly		Parts assembly diagram of an ST 700 Pressure Transmitter
Online/Device Setup/Basic Setup/ Device Information	Honeywell Logo	Photograph of an ST 700 Pressure Transmitter along with the official “Honeywell” logo
	Manufacturer	Displays Manufacturer of the ST 700 Pressure Transmitter: Honeywell International
	Model	Displays Model number of the ST 700 Pressure Transmitter: ST 700
	Install Date	Enter the date of site installation. This is a one-time only configuration.
	MB Type	Displays Meter Body Type of the ST 700 Pressure Transmitter. Possible types are: DP: Differential Pressure AP: Absolute Pressure GP: Gauge Pressure
	MB ID	Displays the Meter Body ID number of the ST 700 Pressure Transmitter
	Tag	Enter tag identification up to eight alphanumeric characters.
	Long Tag	Enter a long tag name up to 32 alphanumeric characters.
	Cfg chng count	Configuration Change Counter – this counter keeps track of the number of times any configuration parameter has been changed

Online/Device Setup/Basic Setup/ Device Information (Continued ...)	Date	Enter a date for user information only.
	Descriptor	Enter a descriptor for user information only (up to 16 alphanumeric characters)
	Message	Enter a message up to 32 alphanumeric characters) that will be sent to the Display. The message will be shown on the Display interspersed with the configured screens. To stop displaying the message, select "Clear Display" in the Device Information menu.
	Clear Message	Selecting this option clears the "Message" and it will no longer be sent to the Display.
	Range values	<p>Displays all of the range information for the device. The following limits are read only:</p> <ul style="list-style-type: none"> LRL: Lower range limit URL: Upper range limit LTL: Lower transducer limit UTL: Upper Transducer limit <p>The following may be configured to desired zero and span ranging for the application:</p> <ul style="list-style-type: none"> LRV: Lower Range Value (input which represents 0% output) URV: Upper Range Value(input which represents 100% output) <p>Valid configurations for LRV and URV range from LTL to UTL.</p>
	Model Number	Displays the full order model number of the ST 700 Pressure Transmitter
	Maint Mode	<p>Displays the Maintenance mode set by Experion PKS.</p> <p>When a HART device requires maintenance, the engineer or the operator changes the PV Source value of the corresponding AI channel to MAN. As soon as the PV Source value is changed for the channels connected to the ST 700 transmitters, Experion communicates the channel mode status to the corresponding ST 700 transmitters. Upon receiving this status, if the value is MAN, the transmitter displays an M and Available for Maintenance on the local display of the transmitter. The status display on the transmitter ensures that the field technician can locate and perform the maintenance work on the correct transmitter without impacting the integrated devices in the process loop. The transmitter continues to display the Available for Maintenance status on its local display until the PV Source status of the corresponding AI channel is changed to AUTO / SUB or the transmitter is power cycled.</p> <p>For more information, refer to the Experion Knowledge Builder</p>

Online/Device Setup/Basic Setup/ Device Information (Continued ...)	Device ID	Displays the HART unique long address of the ST 700 Pressure Transmitter
	Final Asmbly num	Displays the final assembly number of the ST 700 Pressure Transmitter
	Universal rev	Displays the HART Universal Revision of the ST 700 Pressure Transmitter
	Fld dev rev	Displays Field Device Revision of the ST 700 Pressure Transmitter
	Software rev	Displays the Electronics Board Software Revision of the ST 700 Pressure Transmitter
	Loop mA	Select the Loop Current Mode configuration: “Enable”: enables loop current mode (analog output will operate as a 4 to 20 mA signal consistent with the transmitter output) “Disable”: disables loop current mode (analog output will be fixed at 4 mA)
	PV Units	Select one of the pre-programmed engineering units. ST 700 Transmitters with inches of water ranges are factory calibrated using pressure referenced to 39.2°F (4°C). Pressure readings can be displayed in the following engineering units: inH ₂ O inHg mmH ₂ O ftH ₂ O bar mmHg psi mbar g/cm ² kg/cm ² Pa kPa torr atm MPa inH ₂ O @ 4°C mmH ₂ O@4°C inH ₂ O @ 60°F
	PV Damping	Enter a value for damping of the device output. Entries may be any value from 0.00 to 32.00 seconds.
	SV Units	Select the desired unit for measurement of the Secondary Variable (Meter Body Temperature). Selections available are: °C, °F, °R, Kelvin.
Write Protect	Displays the current configuration of the write protect function. Write Protect is “Enabled” if either the write protect jumper on the electronics board is in the “ON” position or the firmware write protect has been enabled.	

Online/Device Setup/Calibration	PV Levels	Displays a graphic representation of all PV ranges and limits for the ST 700 Pressure Transmitter
	Calibration Methods	<p>The following calibration methods are available:</p> <p>Apply Values: performs a Set LRV and/or Set URV to configure the LRV/URV to applied inputs.</p> <p>Enter Values: enter desired LRV and URV value to configure the desired operating range. Valid entries are from LTL to UTL (lower/upper transducer limits).</p> <p>D/A Trim: perform an analog output calibration at 4.00 and 20.00 mA (0% and 100% output).</p> <p>Zero Trim: perform an input calibration correction by applying process input at zero.</p> <p>LRV Correct: perform an input calibration correction by applying process input at the configured LRV level.</p> <p>URV Correct: perform an input calibration correction by applying process input at the configured URV level.</p> <p>Reset Corrects: clear all user calibration adjustments.</p>
	Filter Performance Selection	<p>Configure the desired performance for the Output Speed of Response Filter. Select from:</p> <p>Standard SOR : excellent speed of response to input changes with optimal noise performance</p> <p>Fast SOR: fastest speed of response to input changes</p>
	Correct URV Records	Displays the time and date history records for the last three URV Correct calibrations.
	Correct LRV Records	Displays the time and date history records for the last three LRV Correct calibrations.
	Zero Trim Records	Displays the time and date history records for the last three Zero Trim calibrations.
	Reset Correct Records	Displays the time and date history records for the last three times Reset Corrects was issued.

Online/Device Setup/Process Variables	PV Meter	Displays a gauge meter representation of the current value of the Primary Variable (pressure input)
	PV	Displays the current value of the Primary Variable (pressure input) in user selected engineering units
	Trend of PV	Displays a trending chart of the current value of the Primary Variable (pressure input)
	SV Meter	Displays a gauge meter representation of the current value of the Secondary Variable (meter body temperature)
	SV	Displays the current value of the Secondary Variable (meter body temperature) in user selected engineering units
	Trend of SV	Displays a trending chart of the current value of the Secondary Variable (meter body temperature)
	TV Meter	Displays a gauge meter representation of the current value of the Tertiary Variable (static pressure)
	TV	Displays the current value of the Tertiary Variable (static pressure) in psi
	Trend of TV	Displays a trending chart of the current value of the Tertiary Variable (static pressure)
	ET Meter	Displays a gauge meter representation of the current value of the Electronics Temperature
	ET	Displays the current value of Electronics Temperature in degrees C
	Trend of ET	Displays a trending chart of the current value of the Electronics Temperature
	AO Meter	Displays a gauge meter representation of the current value of the Analog Output
	Trend of AO	Displays a trending chart of the current value of the Analog Output
	PV AO %	Displays a bar graph of the current value of the Analog Output
	PV % rnge	Displays the current value of transmitter Output in %
Online/Device Setup/Device Status	Overall Status	Displays a pictorial representation of the current device status
	Critical	Displays all possible Critical Status faults and indicates OFF for inactive faults or ON for active faults.
	Help – Critical Diagnostics	Provides a more detailed description of each Critical Status fault
	Non-Critical	Displays the first set of possible Non-Critical Status faults and indicates OFF for inactive faults or ON for active faults.
	Help – Non-Critical Diagnostics	Provides a more detailed description of each of the first set of Non-Critical Status faults
	Non-Critical	Displays the second set of possible Non-Critical Status faults and indicates OFF for inactive faults or ON for active faults.
	Help – Non-Critical Diagnostics	Provides a more detailed description of each of the second set of Non-Critical Status faults
	Ext dev status	Displays all possible Extended Device Status faults and indicates OFF for inactive faults or ON for active faults.
	Additional Status	Displays an advanced diagnostic detailed breakdown of all Critical and Non-Critical faults

Online/Device Setup/Diagnostics	Adv Diagnostics	Displays Advanced Diagnostics details for tracking basic device operation. For more detailed information on Advanced Diagnostics, refer to HART Advanced Diagnostics section in this Manual. Diagnostic information includes: Installation and Device Life details PV Tracking details SV Tracking details TV Tracking details ET Tracking details Operating Voltage details AVDD Tracking details Sensor CPU Temp. Tracking details Power Up Diagnostics details
	Config History	Displays a history of the last five configuration parameters that have been changed.
Online/Device Setup/Services	Write Protection	Displays a picture of the Electronics module to demonstrate how to connect the hardware write protect jumper.
	Write Protect	Displays the current configuration of the write protect function. Write Protect is “Yes”(enabled) if either the write protect jumper on the electronics board is in the “ON” position or the firmware write protect has been enabled.
	Write Protect On/Off	Configure the firmware write protect option. Write Protect selections are: “Enable”: enables the firmware write protect option (changes in configuration parameters will not be permitted). “Disable”: disables the firmware write protect option (requires a password). A 4-digit password is required to change the Write Protect option from “Enabled” to “Disabled” to allow configuration changes. The default password is “0000”, and can be re-configured by the user.
	Change Password	Change the write protect password to a new 4-digit code.
	Tamper Mode	Displays the current configuration of the Tamper detection feature (outside attempts to change device configuration when Write Protect is enabled and Tamper Mode is Enabled or Tamper Mode alone is Enabled). Refer to the “Tamper Reporting Logic and Write Protect Logic” in Table 12
Attempt Counter	Displays the number of times a tamper attempt (configuration write) has occurred. This parameter works as below: 1) The attempt counter will get reset on following instances: - When tamper is reset using the “Reset Tamper Counter” Method. - When Tamper Mode is configured. During the configuration, if the Tamper Mode is Enabled and the other Tamper parameters are configured, then that is also considered as a Tamper Attempt. 2) When tamper attempts are already incremented, if tamper is reconfigured then following happens, - If the reconfigured value is greater than tamper attempts, then the tamper attempts value is retained. If the reconfigured value is smaller than tamper attempts, then the tamper attempts value is clamped to the reconfigured attempts.	

Online/Device Setup/Services (Continued ...)	Tamper Latency	Displays the current setting of the Tamper Latency (0-60 seconds). Tamper latency is the time period for which the tamper alarm remains set in response of command 48 and reflected as “Tamper Alarm” Device Status condition.
	Max Attempts	Displays the current setting for the Tamper Maximum Attempts configuration. This is the maximum number of tamper attempts to be permitted during one Latency period before setting the Tamper Alarm status.
	Configure Tamper Mode	Configure all of the settings controlling the Tamper Detection option. Selections include: Select Tamper Mode: enable or disable tampering detection. When enabled, the “Tamper Counter” will keep track of the number of times an attempt is made. After the configured “Max Attempts”, an alarm status is generated. Tamper Latency: Configure the desired latency (in seconds) for the Tamper detection. Maximum Attempts: Configure the maximum number of tamper attempts allowed before the device sets the Tamper Alarm status
	Reset Tamper Counter	Reset the Attempt Counter to zero.
	Master Reset	Selecting this option will cause a Master Reset of the transmitter, which is the equivalent to power cycling the device.
	Loop Test	This function enables the user to test the Analog Output measurement at any value over the full operational range. Select a current value to apply to the output and verify the measured current on the loop with a calibrated meter. Note that this function is only available when “Loop mA” (Loop Current mode) is Enabled.
	Lock/Unlock Device	Select the Lock state for access by HART configuration tools. If “Yes” is selected to lock the device, also select “Yes” or “No” to choose whether or not the lock is “permanent.” If the lock is not permanent, it will be cleared on power cycle or Master Reset of the device. If “Yes” is selected to unlock the device, the lock state will be cleared.

Online/Device Setup/Detailed Setup	Namur Option	<p>Select from the following:</p> <p>Namur Selection: select to enable or disable the Namur option for the output. (Refer to the PV Ranges/Limits chart) for effect on output signal.</p> <p>Namur Level: Displays a diagram of the operating range and failsafe range of the Analog output for Normal and Namur configurations</p>
	Sensors	<p>Displays range information for the Sensor. The following limits are read only: LRL: Lower range limit URL: Upper range limit LTL: Lower transducer limit UTL: Upper Transducer limit</p> <p>Displays the following process variable values: PV: the current value of the PV (primary variable: pressure input)in user selected engineering units SV: the current value of the SV (secondary variable: meter body temperature)in user selected engineering units</p> <p>Allows configuration of the process variable units. See “Device Information” menu for details. PV Units: Select one of the pre-programmed engineering units for the primary variable(pressure input). SV Units: Select one of the pre-programmed engineering units for the secondary variable(meter body temperature).</p>
	Signal Condition	<p>The following signal control parameters may be configured in this menu:</p> <p>PV Damping: Enter a value for damping of the device output. Entries may be any floating point value from 0.00 to 32.00 seconds.</p> <p>PV URV: Upper Range Value or span (input which represents 100% output). Range of entries is from LTL to UTL.</p> <p>PV LRV: Lower Range Value or zero (input which represents 0% output). Range of entries is from LTL to UTL.</p> <p>PV Xfer fnctn: Pressure Transfer function: Select pressure transfer function for calculated output: Linear (output scaled linearly per configured range) Square Root (output scaled as square root conversion per configured range - for flow measurements)</p> <p>PV % range: Displays the current value of AO (analog output) in %</p>

<p>Online/Device Setup/Detailed Setup (Continued ...)</p>	<p>Output Condition</p>	<p>The following output-related values and operations are available in this menu:</p> <p>Poll Address: Select HART short address 0 to 63.</p> <p>Num req preams: displays the number of required request preambles for the ST 700 HART communications</p> <p>PV AO: displays the current value of AO (analog output) in milliamps</p> <p>PV AO Alm Type: displays the current position of the failsafe jumper on the electronics board (upscale/ lowscale burnout)</p> <p>Loop mA: Select the Loop Current Mode configuration: “Enable”: enables loop current mode (analog output will operate as a 4 to 20 mA signal consistent with the transmitter output)</p> <p>“Disable”: disables loop current mode (analog output will be fixed at 4 mA)</p> <p>Loop test: This function enables the user to test the Analog Output measurement at any value over the full operational range. Select a current value to apply and verify the current output on the loop with a calibrated meter. Note that this function is only available when “Loop mA” (Loop Current mode) is Enabled.</p> <p>D/A trim: perform an analog output calibration at 4.00 and 20.00 mA (0% and 100% output).</p>
<p>Online/Device Setup/Meterbody Selections</p>		<p>Displays detailed information pertaining to the Meterbody, including construction configuration, materials of construction, fill fluids, and process connection details.</p>

<p>Online/Device Setup/Display Setup (Continued ...)</p> <p>(for Basic Display Only)</p>	Display Connected	Indicates the type of display installed on the transmitter.
	Read Screen Info	Displays configured information for each of the eight display screens. Select a screen number to view details of the configurations selected in the "Screen Configuration" menu.
	Screen Configuration	<p>The display screen may be customized with the following settings:</p> <p>PV Selection: select the displayed process variable as: Differential Pressure Loop Output Percent Output</p> <p>Pressure Units: select desired standard pressure unit. Number of Decimals: select the number of decimal places for the PV display from none to 3. Custom Tag: enter a custom tag name for the screen title up to 14 alphanumeric characters.</p>
	Common Setup	<p>The following screen options are available:</p> <p>Rotation Time: Set the length of time the PV display is visible before rotating to another screen (such as a diagnostic display). Select from 3 to 30 seconds.</p> <p>Contrast Level: Select a display contrast level from 1(low) to 9 (high) or choose the "default" (5).</p>
Online/Device Setup/Review		Displays the current values for all of the pertinent operating parameters listed in this table, plus revision information. Parameters are not configurable in this menu.

Table 12 – Tamper Reporting Logic Implementation with Write Protect

Write Protect Jumper Status	Write Protect Software Status	Tamper Reporting Status	Tamper Alerted Posted?	Configuration Change Allowed?
ON	ON	ON	YES	NO
ON	OFF	ON	YES	NO
OFF	ON	ON	YES	NO
OFF	OFF	ON	YES	YES
ON	ON	OFF	NO	NO
ON	OFF	OFF	NO	NO
OFF	ON	OFF	NO	NO
OFF	OFF	ON	NO	NO
Jumper Moved		OFF	YES	N/A
Jumper Moved			NO	N/A

The sections below give some examples as to how to edit the configuration parameters and execute Methods.

5.2.10 Procedure to Enter the Transmitter Tag

1. From the **My Device** menu, make the following menu selections:
Shortcuts > Device Setup > Basic Setup > Device Information > Tag.
2. Click **Edit**. The **Tag** screen will be displayed.
3. Key in the tag name (for example: ST 700) which can be a maximum of eight characters.
4. Click **OK**. The **Send to Device** screen will be displayed.
5. Select the **Tag** check box.
6. Click **Send** to download the change to the Transmitter, or Click **Return** to continue making changes.

5.2.11 Selecting the Process Variable (PV) Unit of Pressure Measurement



Engineering units affect the values of the LRV and URV. After changing the PV engineering units to the Transmitter, verify changes to the units parameter, the LRV, and the URV.

The pressure measurement can be displayed in one of the pre-programmed engineering units.

1. From **My Device** menu, make the following menu selections:
Shortcuts > Device Setup > Basic Setup > PV Units
2. Click **Edit**. You will be warned that if you change the value of the variable it will change the loop current, which may upset the control process.
3. Click **Yes** to continue. The PV Unit screen will be displayed with a list of measurement units, as follows:

inH ₂ O	psi	Pa	inH ₂ O@4°C
inHg	bar	kPa	mmH ₂ O@4°C
ftH ₂ O	mbar	Torr	–
mmH ₂ O	g/cm ²	Atm	–
mmHg	kg/cm ²	MPa	

4. Select the desired **PV Unit**, and click **OK**. A Post Edit action message will be displayed, indicating if you select this value, the variables that use it as the units code will start in the previous units until this value is sent to the Transmitter.
5. Click **OK** to continue or **Abort** to discard the change.
6. Click **Send**. The Send to Device screen will be displayed.
7. Select the **PV Unit** check box.
8. Click **Send** to download the change to the Transmitter or **Return** to continue making changes.

5.2.12 Setting PV URV, and LRV Range Values

 ST 700 Transmitters are calibrated at the factory with ranges using inH₂O at 39.2°F (4°C). For a reverse range, enter the upper range value as the LRV and the lower range value as the URV.

When setting the range using applied pressure, the URV changes automatically to compensate for any changes in the LRV. When using the Toolkit keyboard, the URV does not change automatically. To use the applied pressure method and change both the LRV and URV, [change the LRV first](#).

The LRV and URV values can be entered with the Toolkit keypad or by applying the corresponding pressure values directly to the Transmitter. Use the following procedure to key in the range values. The procedure uses an example of 5 to 45 referenced to inH₂O.

1. Starting at the My Device menu, make the following menu selections:
Shortcuts > Device Setup > Basic Setup > Device Information > Range values
2. Click **Edit**. The “Range value” screen will be displayed.
3. Select **PV LRV** and click **Edit**. You will be warned that if you change the value of the variable it will change the loop current, which may upset the control process.
4. Click **Yes** to continue.
5. Enter the desired PV LRV value. (for example: 5).
6. Click **OK**. The Range Values menu will be displayed
7. Choose **Pressure URV**.
8. Add the desired URV setting value (for example: 45).
9. Press **ENTER**.
10. Select the **PV URV**, and click **Edit**. You will be warned that if you change the value of the variable, it will change the loop current, which may upset the control process.
11. Click **Yes** to continue.
12. Click **Return** to go back to the **Basic Setup** menu.
13. Click **Send**. The Send to Device screen will be displayed.
14. Select the **Range values** check box,
15. Click **Send** to download the change to Transmitter, or Click **Return** to continue making changes.

5.2.13 Setting Range Values for Applied Pressure

 When setting the range values using applied pressure, the URV changes automatically to compensate for any changes in the LRV and to maintain the present span (URV – LRV). When entering the LRV using the Toolkit keypad, the URV does not change automatically. If you use the applied pressure method, and need to change the LRV and URV, [change the LRV first](#). You can also use the local zero and span adjustments on the Transmitter to set the LRV and URV values.

1. Starting at the **My Device** menu, make the following menu selections:
Shortcuts > Device setup > Calibration > Calibration Methods > Apply values.

2. Click **Execute**. You will be warned to remove the loop from automatic control. After doing so, press **OK** to continue.
3. Select **4mA** from the list, and then click **OK**. A message will prompt you to apply a new 4 mA input.
4. Click **OK**; otherwise, click **Abort**.
5. When the **Current applied process value:** is displayed, choose **Select as 4mA value**, and click **OK**.
6. Repeat steps 2 through 4 to set the URV to the applied input pressure for 20 mA output.
7. Click **Return** to go back to the Calibration menu.
8. Click **Send**. The Send to Device screen will be displayed.
9. Select the **Apply Values** check-box.
10. Click **Send** to download the change to the Transmitter, or click **Return** to continue making changes.

5.2.14 Saving device history

FDC provides you a feature wherein you can save the device configuration snapshot as history. This history record may then be transferred to a central asset management database such as FDM. Using this feature you can save the device configuration snapshot as device history of a connected device at any given time in a predefined location. The following are the features of save device history option.

- Two formats of history are supported: FDM and DocuMint.
- Only one snapshot per device instance is allowed to be saved and you can save the snapshot of a device any number of times overwriting the existing one.

To save device history, perform the following steps.

1. On Device Home page, tap Tools.
2. Select **Save History** and tap **Select**

The **Save History** page appears.

3. Enter the **History Record Name** using the keypad and tap **OK**. History Name field accepts alphanumeric characters, underscore, and no other special characters.
4. Enter the **Device Tag** using the keypad and tap **OK**. Device Tag field accepts alphanumeric characters, underscore, and no other special characters.

Note: The device can be identified with **History Record Name** and **Device Tag** in FDM, once the record is imported in FDM, provided the device is not already present in the FDM network.

5. Select the **Format**. The following are the available formats:
 - FDM
 - DocuMint
6. Tap **Save** to save device history record.
7. If a history record for this device already exists, the following warning message appears.

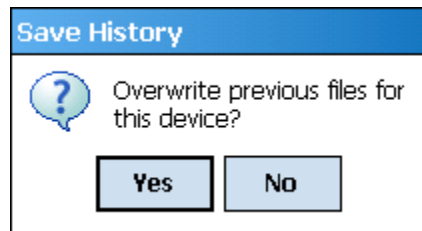

8. Tap **Yes** to overwrite the existing name. A overwrite success message appears.
9. Tap **OK** to return to **Device Home** page.

5.2.15 Exporting device history records to FDM

The history snapshot saved in FDC can be imported into FDM for record and audit purposes. This is enabled by the standard Import/Export wizard in FDM. This way FDM allows synchronizing the device configuration data through the MC Toolkit handheld.

To export device history from FDC and import it in FDM, perform the following steps.

1. Connect your MC Toolkit handheld to your computer as described earlier.
2. Browse to the folder on your computer, **SD Card > FDC > Resources > History**.
3. The FDC history records are named as per the following convention for the primary name:
DeviceTag_ManufacturerIDDeviceTypeDeviceRevisionDDRRevision_DeviceID
4. Copy the desired Device History Record files (with .fdm extension) from the above mentioned location to a temporary location on FDM Client computer.
5. Use FDM Import/Export wizard to import the history records into FDM. After you import successfully:
 - The snapshot would get imported into FDM database and appear as a history record for the corresponding device in FDM.
 - The Audit Trail entry for such a record identifies it as being imported through the MC Toolkit handheld.
 - If the device is not part of any of the FDM configured networks, it would appear under '**Disconnected Devices**' in FDM network view.

- All operations allowed on Device History Record in FDM will be allowed for the record imported through the MC Toolkit handheld.

Note: For more details on using FDM Import/Export feature, refer to section Importing and Exporting Device History in FDM User's Guide.

5.2.16 Exporting device history records to Documint

To export device history from FDC and import it in FDM, perform the following steps.

1. Connect your MC Toolkit handheld to your computer as described earlier.
2. Browse to the folder on your computer, **SD Card > FDC > Resources > History**.
3. The FDC history records are named as per the following convention for the primary name:
DeviceTag_ManufacturerIDDeviceTypeDeviceRevisionDDRRevision_DeviceID
4. Copy the desired Device History Record files (with .xml extension) from the above mentioned location to a temporary location on the DocuMint system.
5. For Importing in DocuMint: Select Procedures > Import or the Import option in the tool bar.

Note: For more details on using DocuMint Import feature, refer to section Importing from XML File in Document Help.

5.2.17 Custom Views



FDC provides you a unique feature wherein you can choose what you want to view in a device and thus creating your own custom views. This is a very convenient utility when you are interested in select few variables in a device and saves you the time for navigating through the menus.

You can create two views per device type with maximum of 10 variables selected for each custom view.

To create/modify the custom views, perform the following.

1. On **Device Home** page, tap **My Views**.
2. Tap **Configure** and tap **Select**.

The **Configure My Views** dialog box appears.

3. To customize **View1** and **View2**, select the variables by checking the box against desired variables.
4. Tap  or  to navigate to previous and next set of variables.
5. Once done, tap **Options** to select **Save My Views**.

Two custom views are ready with selected variables.

Note: Since a custom view can contain only up to 10 variables each, a warning is displayed if you have selected more than 10 variables.

To rename the views, perform the following.

6. Tap **Options > Rename View1**.

A dialog box appears informing you to enter the name.

7. Tap **Ok**.
8. Tap **Option>Save** to persist the change
9. Tap **Return** to return to **My Views** page. You would see two options with the names you gave to the newly created views.

Note: To view the custom views, tap **My View 1 > Select**.
The My View 1 page appears.



The screenshot shows a mobile application window titled "My View 1". It contains a table with three columns: "Label", "Value", and "Unit". Each row in the table has a circular icon to its left, which is either a grey 'V' (indicating Read) or a green 'V' (indicating Write). Below the table is a "Send" button with a downward arrow, and a blue "Return" button at the bottom.

Label	Value	Unit
Config Cha...	32	
Manufactu...	Honeywell	
Model	ST3000	
PV	0.00	s
PV AO	0.000	mA
PV LRV	5.5000	inH2O
PV unit	inH2O	
SV unit	degC	
Tag	STT3K	
Write prot...	No	

Edit the parameters that are Read / Write and select Send.

For more details on any of the FDC features, refer the “*MC Toolkit User Manual*, document # 34-ST-25-20.”

5.2.18 Offline Configuration

5.2.18.1 Overview

Offline Configuration refers to configuring a device when the device is not physically present or communicating with the application. This process enables you to create and save a configuration for a device, even when the device is not there physically. Later when the device becomes available with live communication, the same configuration can be downloaded to the device. This feature enables you to save on device commissioning time and even helps you to replicate the configuration in multiplicity of devices with lesser efforts. Currently, FDC does not support creating offline configuration. However, it supports importing of offline configuration from FDM R310 or later versions. The configurations thus imported can be downloaded to the device from FDC.

The following are the tasks that you need to perform for importing offline configuration in FDC application software and then downloading it to the device.

- Create offline configuration template in FDM
- Save the configuration in FDM in FDM format.
- Import the offline configuration in FDC
- Download the offline configuration to the device

Note: For details on creating and using offline configuration, refer to section Offline configuration in FDM User's Guide.

5.2.18.2 Importing offline configuration

Using this feature you can import offline configuration template. The offline configuration template has to be created in FDM and saved in FDM format. Copy the .fdm files into the storage location of the FDC.

To import an offline configuration, perform the following steps.

1. On the FDC homepage, tap Offline Configuration > Select.

The **Offline Configurations** page appears.

2. Tap **Options** > **Import**.

The **Select a File** dialog box appears.

3. Navigate to the location where the offline configuration template is stored.
4. Select the required offline configuration template from the list.
5. Double-tap and the offline configuration template is imported.

A success message appears.

Note: In case if the offline configuration template is already imported, an overwrite message appears.

6. Tap **OK** to return to the **Offline Configurations** page. The device details appear on the bottom of the page.

5.2.18.3 *Deleting offline configuration*

Using this feature you can delete an offline configuration template.
To delete an offline configuration, perform the following steps.

1. On the FDC homepage, tap **Offline Configuration > Select**.

The **Offline Configurations** page appears.

2. Select the required offline configuration template from the list.
3. Tap **Options > Delete**. A warning message appears.
4. Tap **Yes** to delete the offline configuration template.

5.2.18.4 *Downloading an offline configuration*

Using this feature, you can download the offline configuration when the device is online.

To download an offline configuration, perform the following steps.

1. On the FDC homepage, tap **Offline Configuration > Select**.

The **Offline Configurations** page appears.

2. Select the required offline configuration template from the list.
3. Tap **Options > Download**.

The **Offline – Select Variables** page appears with the all the variables.

Note: By default, all the variables selected in FDM will appear as selected and non-editable variables appear in grey color.

4. Select the required variable. In case you select a dependent variable, then variables on which it is dependent on will also be selected and the following warning appears.

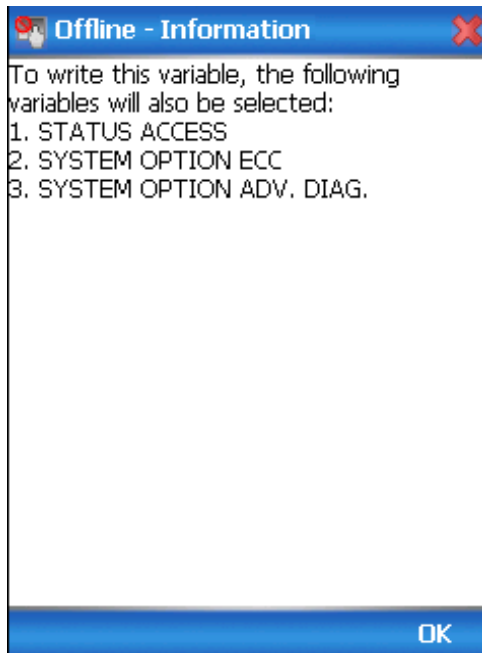

5. Tap **OK** to return to the offline wizard.
6. Tap **Next**.

The **Offline – Review and Send** page appears with the list of selected variables.

- Tap **Send** and the process to send the variables to the device starts. Once the downloading is complete, the following page appears.

Offline - Status		
Label	Value	Status
SV unit	degC	SUCC...
Transfer function	Linear	SUCC...
PV LRV	0	FAILED
PV unit	inH2O	SUCC...
Units	%	SUCC...
Date	1/1/80 12...	SUCC...
Descriptor	?????????...	SUCC...
Poll addr	0	SUCC...
PV URV	0	SUCC...

Send
Finish

Note: If the variables are downloaded successfully, status appears as **SUCCESS** in green color; and if failed, status appears as **FAILED** in red color.

- Tap **Finish** to return to **FDC Homepage**.

6 DE Calibration

6.1 Overview

The ST 700 SmartLine Pressure Transmitter does not require periodic calibration to maintain accuracy. Typically, calibration of a process-connected Transmitter may degrade, rather than augment its capability. For this reason, it is recommended that a Transmitter be removed from service before calibration. Moreover, calibration will be accomplished in a controlled, laboratory-type environment, using certified precision equipment.

6.2 Calibration Recommendations

If the Transmitter is digitally integrated with a Honeywell Total Plant Solution (TPS) system, you can initiate range calibration and associated reset functions through displays at the Universal Station, Global User Station (GUS), and Allen-Bradley Programmable Logic Controllers (PLCs). However, a range calibration using the MC Toolkit with the Transmitter removed from service is recommended.

Calibration with the Transmitter removed from service needs to be accomplished in a controlled environment. Details for performing a calibration reset through the Universal Station are provided in the *PM/APM SmartLine Transmitter Integration Manual*, PM12-410, which is part of the TDC 3000^X system book set.

6.3 Test Equipment Required for Calibration

Depending upon the type of calibration you choose, you may need any of the following test equipment to accurately calibrate the transmitter:

- Digital Voltmeter or millimeter with 0.01% accuracy or better
- Honeywell MC Toolkit: Use the **MC Toolkit** application to calibrate the ST 700 DE model and the **FDC** application to calibrate the ST 700 HART model.
- Calibration-standard input source with a 0.01% accuracy
- 250 ohm resistor with 0.01% tolerance or better.

6.4 Analog Output Signal Calibration

The Transmitter analog output can be calibrated at its zero (0) and 100% levels using a constant-current source mode. The Transmitter does not have to be removed from service for the analog output signal calibration procedure.

The following procedure provides the steps for calibrating the output signal for a Transmitter in the analog mode. The procedure is similar for a Transmitter in the DE mode, but the MC Toolkit is required to read the output in percent in place of current or voltage. Figure 10 illustrates the test setup for the analog output calibration process.

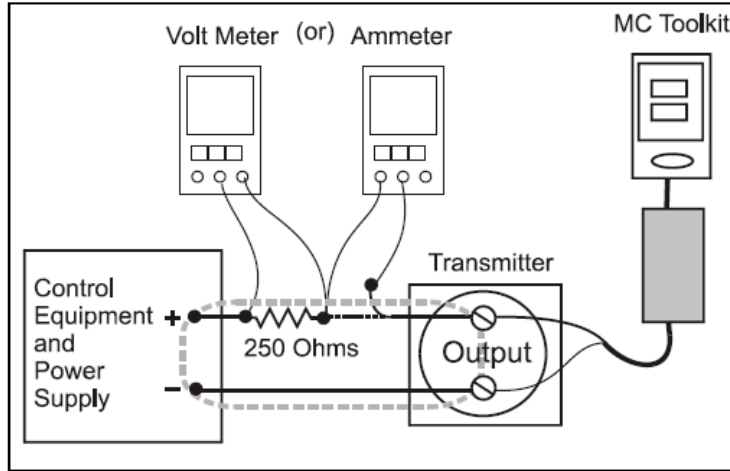
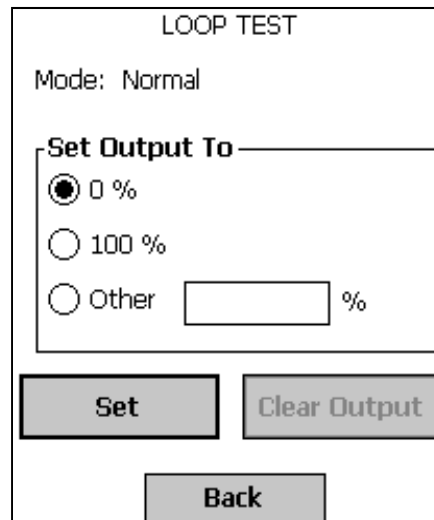

Figure 10 – Analog Output Calibration Test Setup

1. Verify the integrity of the electrical components in the output current loop.
2. Connect the MC Toolkit as indicated, and establish communication with the Transmitter. For these procedures, values of components in the current loop are not critical, if they support reliable communication between the Transmitter and the MC Toolkit.
3. Start the MC Toolkit application, and establish communication with the Transmitter.
4. In the Output Calibration box, select the **Loop Test** button to display the LOOP TEST box.
5. Select the desired constant-level Output: **0 %**, **100 %**, or **Other** (any of **0 % - 100 %**).



6. Select the **Set** button. You will be prompted to confirm that you want to put the Transmitter in output mode.

7. Select **Yes**, and note the output current at 0%, 100% or the other value established in the previous step. With the Transmitter in analog mode, you can observe the output on an externally connected meter or on a display. In DE mode, the output can be observed on the display or on the monitor display of the MC Toolkit.
8. To view the Monitor display, navigate back from the LOOP TEST display, and select the MONITOR display. A confirmation prompt will be displayed for you to verify that you want to change pages. Select **Yes**.

6.5 Calibrating Range Using the MC Toolkit

The range calibration involves two procedures, one to calibrate the input, the other to calibrate the output. This section provides both procedures.

6.6 Conditions for Input Calibration

Calibrate Transmitter input only when necessary, and under conditions that will ensure accuracy:

- Take Transmitter out of service, and move it to an area with favorable environmental conditions, for example, clean, dry, and temperature-controlled
- The source for the input pressure must be precise, and certified for correct operation.
- Qualified personnel are required for the input calibration procedure.

To optimize accuracy, the PROM includes storage for calibration constants: Correct Input Zero, Correct LRV, and Correct URV. These constants provide for optimum accuracy in that they enable fine-tuning of the input calculations by first correcting at zero input, then by bounding the input calculations at the selected operating range. Corrections are applied at the Lower Range Value (LRV) and the Upper Range Value (URV).

Factory calibration can be specified when you order your Transmitter. Also, if precision equipment, suitable environment, and required skill are available at your site, input calibration can be done locally.

The input calibration procedure in this section comprises the steps for calibrating a differential pressure (DP) Transmitter to a range of 0 to 200 in H₂O for example purposes. This procedure assumes that the Transmitter is removed from the process and located in a controlled environment.

The procedure needs a precision pressure source with an accuracy of 0.04% or better to do a range calibration. Factory calibration of the ST 700 Pressure Transmitter is accomplished with inches-of-water ranges referenced to a temperature of 39.2 °F (4°C).

6.7 Input Calibration Procedures Description

The input calibration process consists of the following three parts:

- Correcting the input at zero pressure.
- Correcting the input LRV.
- Correcting the input URV.



For the input calibration procedure, current loop component tolerances and values are not critical if they support reliable communication between the Transmitter and the MC Toolkit. However, the **Transmitter must be level**, because the meter body contains fluids that can affect zero sensing. For leveling procedures. Refer to the ST 700 SmartLine Transmitter User's Manual, 34-ST-25-44, "Mounting Transmitters with Small Absolute or Differential Pressure Spans" for information on Transmitter leveling.

For the input calibration procedures, connect the test setup illustrated in. Either voltage mode (Voltmeter across the resistor) or current mode (Ammeter in series with the resistor) is satisfactory.

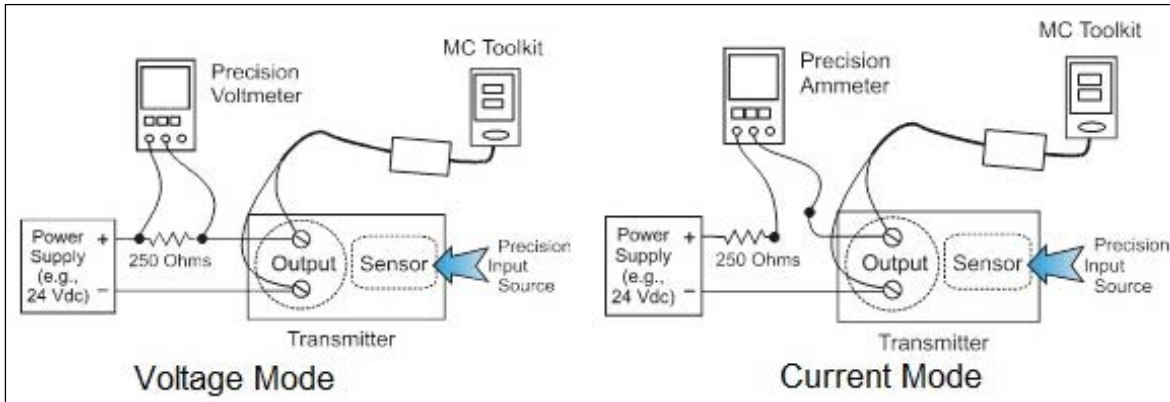

Figure 11 – Input Calibration Connections

6.8 Input Calibration Procedure

6.8.1 Correct the Input at Zero

1. Start the **MC Toolkit** application. Establish communication between the Transmitter and the MC Toolkit.
2. From the DE MAIN MENU, select **Configure** to call up the DE CONFIGURE display.

DE CONFIGURE	
LRL <input type="text" value="-10.0"/>	URL <input type="text" value="10.0"/>
LRV <input type="text" value="0.19371"/>	URV <input type="text" value="10.194"/>
PV Units <input type="text" value="inH2O @ 39F"/>	SV Units <input type="text" value="°C"/>
Sensor Type <input type="text" value="DP"/>	Damping <input type="text" value="32.00"/>
Span <input type="text" value="10.0"/>	Conformity <input type="text" value="Linear"/>
<input type="button" value="Send"/>	<input type="button" value="Back"/>

3. From the DE CONFIGURE display:
 - a. Use the **PV Units** drop-down list to select the appropriate engineering units.
 - b. Use the keyboard to enter the desired **LRV** and **URV** values.
 - c. Select the **Send** button to copy the newly entered values to the Transmitter. When the copy operation is complete, **Send** will be displayed in half-intensity.
4. Select the **Back** button to go to the DE MAIN MENU; then select the **Calibration** button. The CALIBRATION box will be displayed.
5. Select the **Back** button to go to the DE MAIN MENU; then select the **Calibration** button. The CALIBRATION box will be displayed.

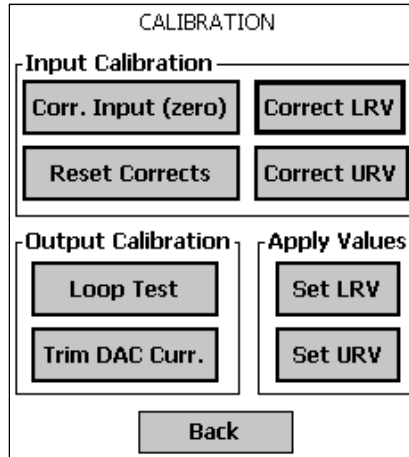

6. Select **Corr. Input (zero)**. The following advisory message will be displayed:

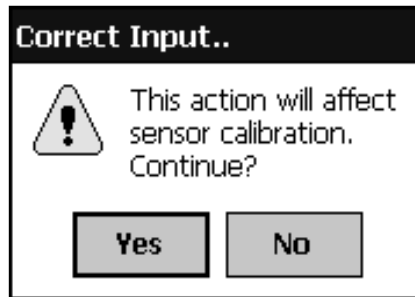

The PV Input (Zero) refers to a known standard such as zero pressure (e.g.: vent both sides of a DP transmitter). As indicated below, this procedure will shift the slope up or down to eliminate the error at the zero reference. The slope (angle) of the response is unchanged.

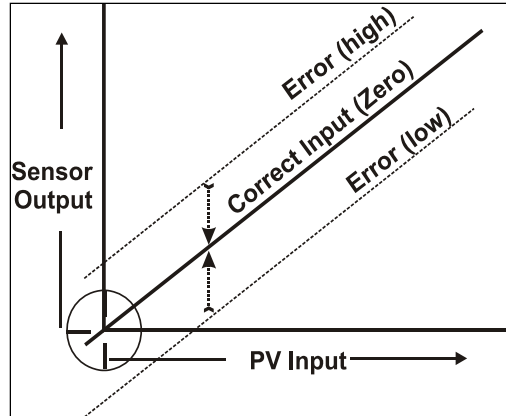

7. Select **Yes** in the **Correct Input..** message box, and you will be prompted to **Apply the PV Input (Zero) now**.
8. Verify that the *value* of the PV applied at the input is *exactly Zero*. Then select **OK** to send the Correct Input (Zero) command to the Transmitter, which adjusts the input calibration.
9. Wait for the message **Sensor input has stabilized**, then select **OK**.
10. When the zero correction is complete, the message **Sensor zero succeeded!** is displayed; select the **OK** button.

6.8.2 Correct Input at the Lower Range Value (LRV)

1. After the LRV and URV have been entered, as described in the “Correct Input at Zero” procedure, above, select the **Correct LRV** button on the CALIBRATION display. (See Step 4 in the previous procedure to bring the CALIBRATION screen to the display.)
2. Select the **Correct LRV** button. This message appears:

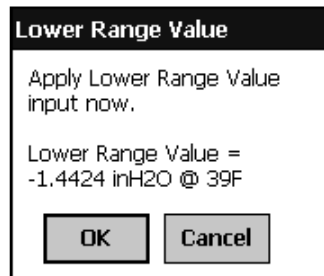

3. Adjust the PV input pressure to the *exact value of the LRV* entered in the DE CONFIGURE display.
4. Select the **OK** button; this message appears:

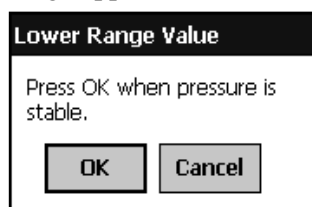

5. Observe the input pressure at the applied value; when it is stable, select the **OK** button.

- When the Transmitter has completed the LRV correction, this message appears:

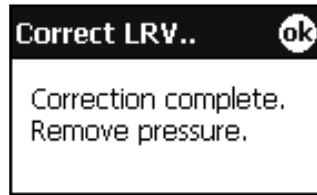

- Select **OK** to acknowledge.

6.8.3 Correct Input at URV

- Select the **Correct URV** button. This message appears.

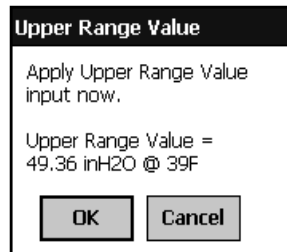

- Adjust the PV input pressure to **the exact value of the URV** entered in the DE CONFIGURE display.

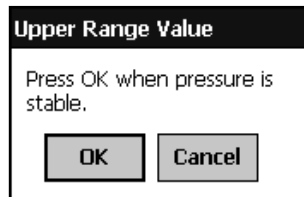

- Select the **OK** button.
- When the transmitter has completed the URV correction, this message appears.

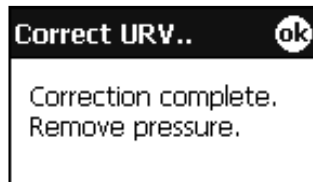

- Select **OK** to acknowledge.

6.9 DE Output Calibration

6.9.1 Output Calibration Preparation

This procedure applies to DE Transmitters operating in analog (current) mode only. First, verify the integrity of the electrical components in the output current loop. Make the connections shown in Figure 12, and establish communication with the Transmitter.

Connect the MC Toolkit as indicated, and establish communication with the transmitter.

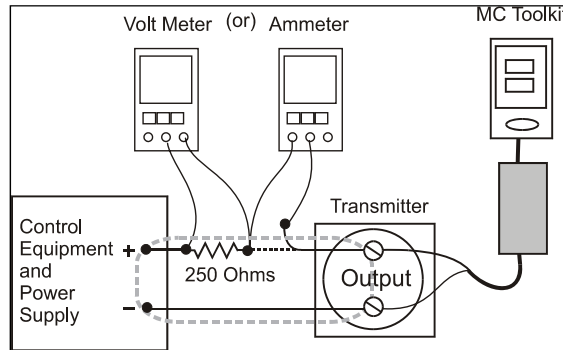

Figure 12 – Output Calibration Test Connections

The purpose of Analog output calibration is to verify the integrity of electrical components in the output current loop. For Output calibration, establish the test set up shown in Figure 12. Values of components in the current loop are not critical if they support reliable communication between the Transmitter and the Toolkit.

For a DE Transmitter operating in analog mode, calibrate the analog output current to the Process Variable (PV) input range such that 4 mA corresponds to the LRV of 0% and 20 mA corresponds to the URV of 100%. Figure 13 shows the PV scale and representative process system connections.

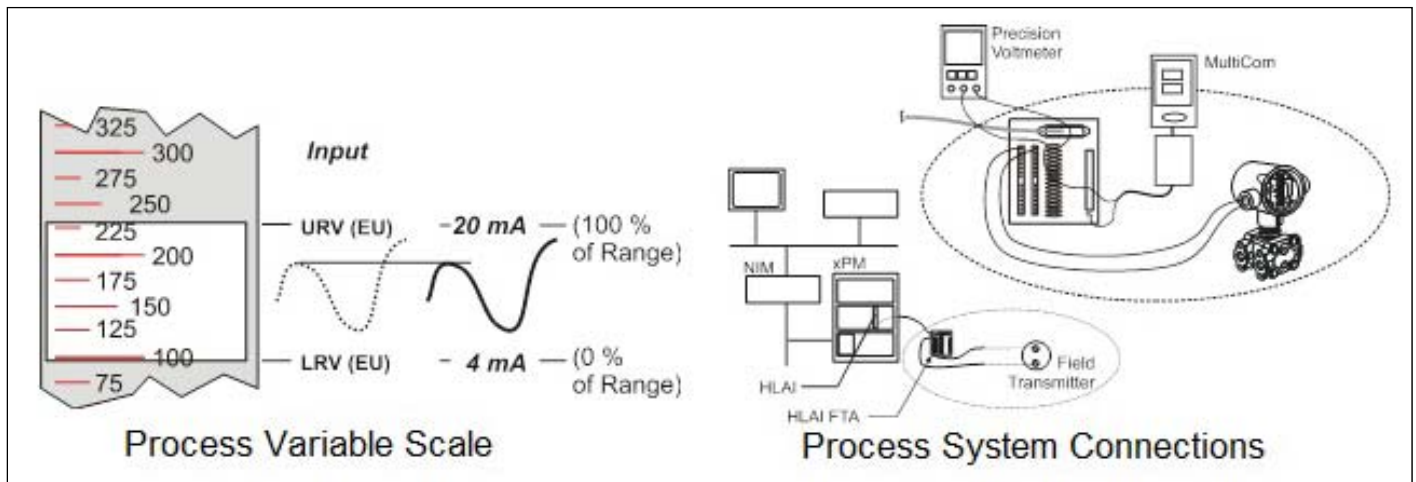

Figure 13 – DE Analog Mode Scaling and Test Connections

1. Start the MC Toolkit application such that the DE MAIN MENU is displayed.
2. Select the **Calibration** button to display the CALIBRATION menu.

3. Select **Trim DAC Curr.** To display the TRIM DAC CURRENT box.

4. Trim output current as follows:
 - a. Select **Set Output To 0%** or **100%**. You will be prompted to confirm that you want to place the Transmitter in output mode.
 - b. Verify that the loop is in manual control. In output mode, output current is fixed at the 0% or 100% level as selected in the TRIM DAC CURRENT box in the previous step.
 - c. Select **Yes**, and observe the loop current level. A meter reading of 4 mA corresponds to 1 volt.
 - d. Use the Toolkit to adjust the loop current to the Zero Percent level (4mA). If the current is low, tap the **Increment** button; if the current is high, tap the **Decrement** button. Note that the value on the meter changes accordingly. If the error is large, accelerate the adjustment rate by changing the Step Size to 10 or 100.
 - e. After establishing the zero current level (4 mA), select **Set Output To 100%**. A meter reading of 20 mA corresponds to 5 volts.
 - f. Use the **Increment** or **Decrement** button, as necessary to adjust the output current to 20 mA. When the current reaches the 20 mA level, select **Clear Output**; the button will change to half-intensity.

5. Change the display in output mode as follows:
 - a. Selecting the **Back** button before selecting the **Clear Output** button, you will be prompted to confirm that you want to clear the output.
 - b. If you want to stay in output mode while viewing other displays, select **Yes**; otherwise, select **No** and the **Clear Output** button.

6.10 Manually Setting the Process Variable Range

This procedure applies to DE Transmitters operating in both DE mode and analog (current) mode. During this procedure, the PV input will be set to 0%, which will be applied as the LRV. Further, the PV input will be set to 100% and applied as the URV.

1. Establish the test connections shown below. Then start the MC Toolkit application to display the DE MAIN MENU.

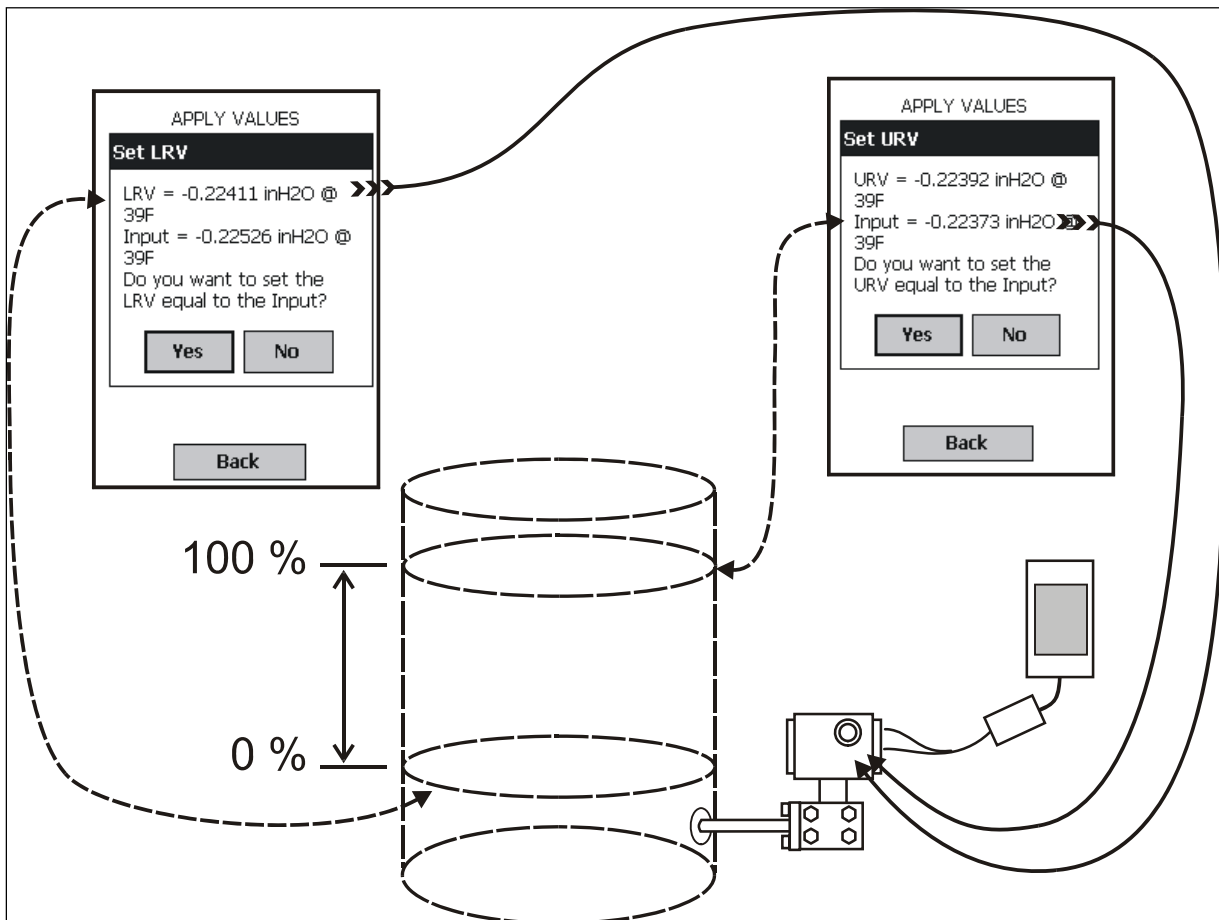
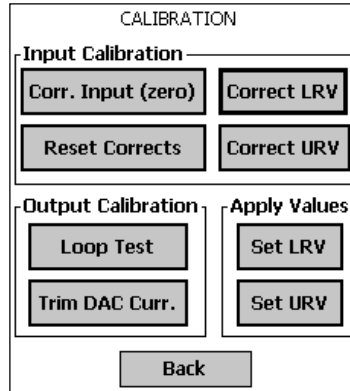
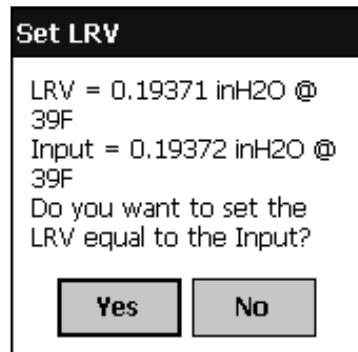

Figure 14 – Setup to Manually Set the PV LRV and URV

2. Select the **Calibration** button to display the CALIBRATION menu.



3. In the **Apply Values** group, select **Set LRV**. The following message will be displayed;



- a. The value of the input shown in the Set LRV box above updates only when the popup is called up.
 - b. To update the input value, select **No**, and then select the **Set LRV** button in the CALIBRATION display.
4. Set the LRV as follows:
 - a. While observing the PV value at the physical process element (using a sight glass, for example), adjust it to the desired minimum (0 %) level, then select **Set LRV**.
 - b. If the displayed value is satisfactory, select **Yes** to copy the Input Value to the LRV in the Transmitter. If not, select **NO** and repeat this step.

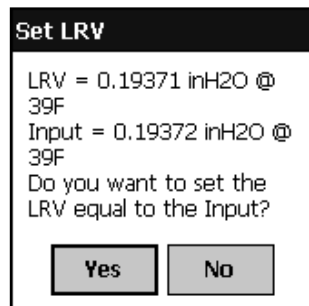

5. Set the URV as follows:
 - a. While observing the PV value at the physical process element (using a sight glass, for example), adjust the process variable to the desired maximum level, and then select **Set URV**.
 - b. If the displayed value is satisfactory, select **Yes** to copy the Input Value to the URV in the Transmitter. If not, select **NO** and repeat this step.

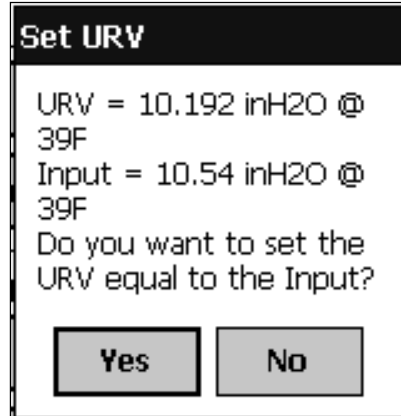

6. Verify the LRV and URV settings as follows:
 - a. Call up the DE CONFIGURE display, and observe that the settings are established in Steps 4 and 5.
 - b. This concludes the procedure to manually set the operating range.

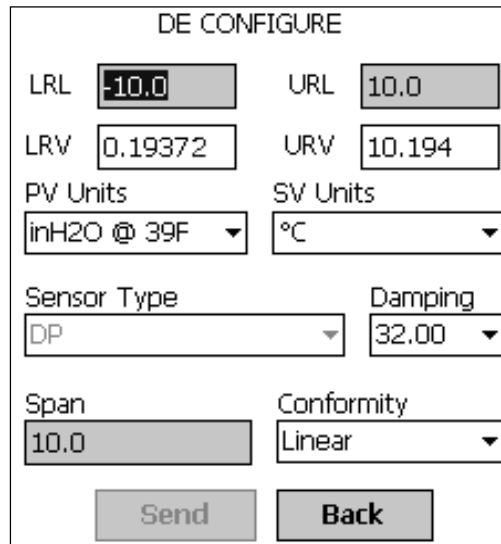

6.11 Procedure to Reset Calibration

ST 700 SmartLine DE Pressure Transmitter can erase incorrect calibration data by resetting the device back to default values using the Toolkit. The default values return the Transmitter calibration to the original factory *characterization* values. However, note that this is not the *final factory calibration*, which is performed per the ordered range. While resetting the calibration will return the Transmitter to a close approximation of the previous calibration using its stored characterization data, the accuracy of the *reset* values will be lower than the specified final calibrated accuracy. It is recommended that input calibration procedure be performed after calibration reset.

1. Connect the MC Toolkit per figure 6. Start the MC Toolkit application into operation such that the DE MAIN MENU is displayed, and establish communication with the Transmitter.
2. From the DE MAIN MENU, select **Calibration**. The CALIBRATION menu will be displayed.

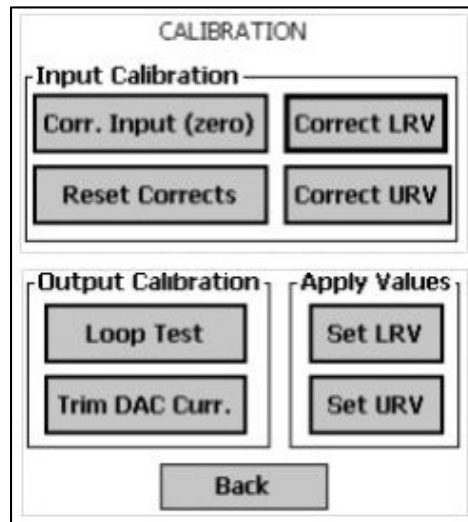

3. Select **Reset Corrects**. The following prompt will be displayed.

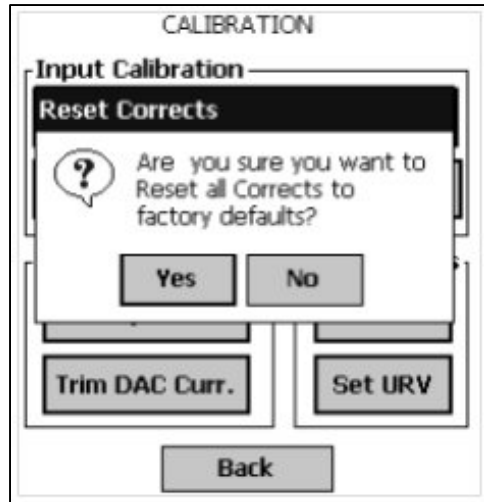

4. If corrects should not be overwritten with factory values, select **No**. If corrects need to be overwritten, select **Yes**. The timer will appear briefly, indicating the operation is performed



This function commands the transmitter to overwrite all user input corrections with factory default ("characterization") values. It is intended for use only when excessive corrections render the transmitter inaccurate. It is highly recommended that input calibration procedure be performed after calibration reset.

7 HART Calibration

7.1 About This Section

This section provides information about calibrating a Transmitter's analog output and measurement range. It also covers the procedure to reset calibration to the default values as a quick alternative to measurement range calibration.

This section includes the following topics:

- How to calibrate a Transmitter's analog output circuit using the Communicator
- How to perform a two-point calibration of a Transmitter
- How to perform a correct reset to return a Transmitter calibration to its default values.

7.1.1 About Calibration

The ST 700 SmartLine Transmitter does not require calibration at periodic intervals to maintain accuracy. If a recalibration is required, we recommend that perform a bench calibration with the Transmitter removed from the process and located in a controlled environment to get the best accuracy.

Before you recalibrate a Transmitter's measurement range, you must calibrate its analog output signal. See section 6.10 for the procedure.

You can also use the FDC application to reset the calibration data to default values, if they are corrupted, until the Transmitter can be recalibrated. See Section 6.8 for details.



All procedures in this manual assume the Transmitter is configured for Loop Current Mode enabled).

7.1.2 Equipment Required

Depending on the selected calibration, you may need any of the following test equipment items to accurately calibrate the Transmitter:

- Digital Voltmeter or millimeter with 0.02% accuracy or better
- MC Toolkit Calibration standard pressure source with a 0.02% accuracy
- 250 ohm resistor with 0.01% tolerance or better.

7.2 Analog Output Signal Calibration

With a Transmitter in its constant current source mode, its analog output circuit can be calibrated at its 0 (zero)% and 100% levels. It is not necessary to remove the Transmitter from service.

The following procedure is used for analog output signal calibration.

You can calculate milliamperes of current from a voltage measurement as follows:

Dc milliamps = 1000 X voltage/resistance



IMPORTANT: Be sure that the accuracy of the resistor is 0.01% or better for current measurements made by voltage drop.

1. Connect the MC Toolkit across loop wiring, and turn it on.
2. Launch the FDC application.
3. On the Home page, select Online and establish a connection with the device as follows;
4. Select the My Device menu, and choose from the following menus:
 - a. Device setup \ Calibration \ Calibration Methods \ D/A trim
5. You will be prompted to remove the loop from automatic control; after removing the loop from automatic control, press OK.
6. When a prompt appears, connect a precision millimeter or voltmeter (0.03% accuracy or better) in the loop to check readings, and press OK. The following prompts will be displayed:
 - Setting field device to output to 4mA. Press OK
 - Enter meter value. Key in the meter value, and press ENTER.
 - Field device output 4.000 mA equal to reference meter?
 - 1 Yes
 - 2 No

If the reference meter is not equal to the field device output then select No and press Enter
Key in the new meter value
Return back to the "Enter Meter Value" prompt until the field device output equals the reference meter
Select Yes and press Enter
7. The following display prompts will appear:
 - Setting field device output to 20mA. Press OK
 - Enter meter value. Key in the meter value, and press ENTER.
 - Field device output 20.000 mA equal to reference meter?
 - 1 Yes
 - 2 No
 - If the reference meter is not equal to the field device output then select No and press Enter
 - Key in the new meter value
 - Return back to the "Enter Meter Value" prompt until the field device output equals the reference meter
 - Select Yes and press Enter
8. The prompt notifies you that the field device will be returned to its original output

7.3 Calibrating Range

The ST 700 SmartLine Pressure Transmitter supports two-point calibration. This means that when two points in a range are calibrated, all points in that range adjust to the calibration.

The procedures in this section are used to calibrate a differential pressure (DP) Transmitter to a range of 0 to 200 inH₂O for example purposes. This procedure assumes that the Transmitter has been removed from the process and is located in a controlled environment.



IMPORTANT! You must have a precision pressure source with an accuracy of 0.02% or better to do a range calibration. Note that the factory calibrates ST 700 SmartLine Pressure Transmitters using inches of water pressure reference to a temperature of 39.2°F (4°C).

7.3.1 Correcting the Lower Range Value (LRV)

1. Connect a power supply and the MC Toolkit to the signal terminals of the Transmitter's terminal block.
2. Connect the precision pressure source to the high pressure side of the DP-type Transmitter.
3. Turn on the power supply, and allow the Transmitter to become stable.
4. Turn the MC Toolkit on, start the FDC application.
5. On the FDC Home page, select Online, and establish communication with the Transmitter.
6. Select the My Device menu, and choose from the following selections:
 - a. Device Setup \ Calibration \ Calibration Methods \ LRV Correct
7. You will be prompted to remove the loop from automatic control. After removing the loop from automatic control, press OK.
8. When prompted, adjust the pressure source to apply pressure equal to the LRV (0%), and press OK.
9. When the pressure stabilizes, press OK.
10. When prompted, remove pressure.
11. On the next prompt – “Please enter current Calibration Time in 24 Hr Clock format (Hour field)”, enter the hour portion of the calibration time in the 24 Hr format HH, for example “12,” and press Enter.
12. On the next prompt – “Please enter current Calibration Time (Minute field),” enter the Minutes field MM (example 23), and press ENTER..
13. When prompted to return the loop to automatic control, press ENTER

7.3.2 Correcting the Upper Range Value (URV)

1. Connect the power supply and communicator to the signal terminals of the Transmitter terminal block.
2. Connect the precision pressure source to the high pressure side of the DP-type Transmitter.
3. Turn on the power supply, and allow the Transmitter to become stable.
4. Turn on the MC Toolkit, and start the FDC application into operation.
5. On the FDC Home page, select Online, and establish communication with the Transmitter.
6. Select the My Device menu, and choose one of the following options:
 - a. Device Setup \ Calibration \ Calibration Methods \ URV Correct
7. You will be prompted to remove the loop from automatic control. Press OK
8. When prompted, adjust the pressure source to apply pressure equal to the URV (100%), and press OK.
9. When pressure stabilizes, press OK.
10. When prompted, remove the pressure.

11. On the next prompt – “Please enter Calibration Date in MM/DD/YYYY format, for example “05/27/2009,” and press Enter.
12. On the next prompt – “Please enter current Calibration Time in 24 Hr Clock format (Hour field)”, enter the hour portion of the calibration time in the 24 Hr format HH, for example “12,” and press Enter.
13. On the next prompt – “Please enter current Calibration Time (Minute field),” enter the Minutes field MM (example 23), and press Enter.
14. When prompted, return the loop to automatic control, and press Enter.

7.3.3 Resetting Calibration

ST 700 SmartLine HART Pressure Transmitter can erase incorrect calibration data by resetting the device back to *final factory calibration*, which is performed per the ordered range. The Corrects Reset command returns the zero and span calibration factors to the original precise factory calibration.

The following procedure is used to reset calibration data to factory calibrated range using the communicator.

1. Connect the MC Toolkit per figure 6 across the loop wiring and turn on.
2. Turn the MC Toolkit on, start the FDC application.
3. On the FDC Home page, select Online, and establish communication with the Transmitter.
4. Select the My Device menu, and choose from the following selections:
 - a. Device Setup \ Calibration \ Calibration Methods \ Reset Corrects
5. You will be prompted to remove the loop from automatic control. After removing the loop from automatic control, press OK.
6. You will be notified that a Reset Corrects is about to occur. Press OK
7. When the message “Reset Corrects OK” appears, press OK. The previous calibration “Corrects” are removed and calibration is reset to the factory values.
8. When prompted to return the loop to automatic control, press OK

7.3.4 Calibration Records

A history of the date and time of the last three Calibration procedures is available for the HART device. Run the Methods and follow the screen prompts to read the Calibration Records.

Select “My Device\Device Setup\Calibration” to select the following calibration records

- Correct URV Records
- Correct LRV Records
- Zero Trim Records
- Reset Corrects Records

Table 13 – Calibration Records

Calibration Record	Description
Trim Records	
Curr Zero Trim	Date and Time of current zero trim field calibration displayed in mm/dd/yyyy format
Last Zero Trim	Date and Time of last zero trim field calibration displayed in mm/dd/yyyy format
Prev Zero Trim	Date and Time of previous zero trim field calibration displayed in mm/dd/yyyy format
Correct LRV Records	
Curr LRV Correct	Date and Time of current LRV correct done displayed in mm/dd/yyyy format
Last LRV Correct	Date and Time of last LRV correct done displayed in mm/dd/yyyy format
Prev LRV Correct	Date and Time of previous LRV correct done displayed in mm/dd/yyyy format
Correct URV Records	
Curr URV Correct	Date and Time of current URV correct done displayed in mm/dd/yyyy format
Last URV Correct	Date and Time of last URV correct done displayed in mm/dd/yyyy format
Prev URV Correct	Date and Time of previous URV correct done displayed in mm/dd/yyyy format
Reset Correct Records	
Curr Corrects Rec	Date and Time of current Reset corrects done displayed in mm/dd/yyyy format
Last Corrects Rec	Date and Time of last Reset corrects done displayed in mm/dd/yyyy format
Prev Corrects Rec2	Date and Time of current Reset corrects done displayed in mm/dd/yyyy format

8 HART Advanced Diagnostics

8.1 About This Section

This section provides information about the Advanced Diagnostic features in the ST 700 SmartLine Pressure Transmitter.

8.2 Advanced Diagnostics

Table 14 – Viewing Advanced Diagnostics

What you want to view	What to do
<ul style="list-style-type: none"> • Install date • PV (Process Variable) Tracking Diagnostics • SV (Meter Body Temperature)Tracking Diagnostics • TV (Static Pressure) Tracking Diagnostics (DP transmitters only) • ET (Electronics Temperature) Tracking Diagnostics • Stress Life • Service Life • Operating Voltage Tracking Diagnostics • AVDD (Sensor Supply Voltage) Tracking Diagnostics • Sensor CPU Temp. Tracking • Power Up Diagnostics 	<p>Select Start/FDC to Launch the FDC application on the MC Toolkit.</p> <p>On the Home page, select Online and establish connection with the device.</p> <p>Select My Device\Diagnostics\Adv Diagnostics.</p>

8.2.1 Install Date

Install Date	Parameter	Description	Date of device installation. Date displayed in mm/dd/yyyy format where mm=month, dd=day, yyyy=year
		Set-up	User enters a date once during device lifetime. Once date is entered no further updates are possible and value becomes read only and is permanently saved.

8.2.2 PV Tracking Diagnostics

Table 15 – Maximum PV Tracking

UTL (Max PV Limit)	Parameter	Description	Upper Transducer Limit: PV(pressure) specified upper operating limit in user-selected units
		Set-up	None.
PV Upper Limit for Stress tracking	Method	Description for DP type	Actual limit value used to note “Time Above Limit” and “Time Since Last Event”. “PV Upper Stress Limit” value is equal to Upper Transducer Limit less 10% of Transducer limits range.
		Example for DP Type	For STD120 span is 0 to 400 inH ₂ O. Range is 400 inH ₂ O settable within LTL = -800 inH ₂ O to UTL = 800 inH ₂ O limits. “PV Upper Stress Limit” = 800 inH ₂ O - 160 inH ₂ O = 640 inH ₂ O.
		Example for AP and GP Types	For STA140 allowable working pressure is 0 to 500 psia. Withstand Pressure from LTL = 0 to UTL = 750 psia. “PV Upper Stress Limit” = 750 psia – 75 psia = 675 psia.
		Set-up	None – calculation is automatic.
Max PV	Parameter	Description	Maximum PV that the device has experienced in user selected units.
		Set-up	None. Value initialized to Min PV Limit value prior to leaving the factory. Updates to current PV automatically when powered at user site after one minute.
		NVM	Update after every 8 hours.
Time Above Upper Stress Limit	Parameter	Description	Accumulation of minutes that pressure measured by the device has been above “PV Upper Stress Limit”.
		Set-up	None – initialized to zero prior to leaving the factory.
		NVM	Backup once each 8 hour period
Time Since Last PV Up	Method	Description	Time that has passed since the last time device’s PV passed above “PV Upper Stress Limit” (in days, hours and minutes).
		Set-up	None – initialized to zero prior to leaving the factory.
		NVM	Backup once each 8 hour period

Table 16 – Minimum PV Tracking

LTL (Min PV Limit)	Parameter	Description	Lower Transducer Limit: PV(pressure) specified lower operating limit in user-selected units
		Set-up	None.
PV Lower Limit for Stress Condition	Method	Description	Actual limit value used in “Time Below Limit” and “Time Since Last Event”. Value is equal to “Min PV Limit” plus 10% of limits range for DP type devices and zero for GP and AP type devices.
		Example for DP Type	For STD120 span is 0 to 400 inH ₂ O. Range is 400 inH ₂ O settable within LTL = -800 inH ₂ O to UTL = 800 inH ₂ O limits. “PV Lower Stress Limit” = -800 inH ₂ O + 160 inH ₂ O = -640 inH ₂ O.
		Example for AP and GP Types	For STA140 allowable working pressure is 0 to 500 psia. Withstand Pressure from LTL = 0 to UTL = 750 psia. “PV Lower Stress Limit” = 0 psia.
		Set-up	None – calculation is automatic.
Min PV	Parameter	Description	Minimum PV that the device has experienced in user selected units.
		Set-up	None. Value initialized to Max PV Limit value prior to leaving the factory. Updates to current PV automatically when powered at user site after one minute.
		NVM	Update after every 8 hours
Time Below Lower Stress Limit	Parameter	Description	Accumulation of minutes that pressure measured by the device has been below the value of “PV Lower Stress Limit”.
		Set-up	None.
		NVM	Backup once each 8 hour period
Time Since Last PV Down	Method	Description	Time that has passed since the last time device’s PV passed below the value of “PV Lower Stress Limit” (in days, hours and minutes).
		Set-up	None – initialized to zero prior to leaving the factory.
		NVM	Backup once each 8 hour period

8.2.3 SV Tracking

Table 17 – Maximum SV Tracking

Max SV Limit	Parameter	Description	Meterbody Temperature (SV) upper operating limit from specification.
		Set-up	None.
Max SV Value	Parameter	Description	Highest Meterbody Temperature ever experienced by the device.
		Set-up	None - value initialized to Min SV Limit value prior to leaving the factory. Updates to current Meterbody Temperature automatically when powered at user site after one minute.
		NVM	Update after every 8 hours.
Time Above Upper Stress Limit	Parameter	Description	Accumulation of minutes that device's Meterbody Temperature has been above the value of "SV Upper Stress Limit".
		Set-up	None.
		NVM	Backup once each 8 hour period
Time Since Last SV Up	Method	Description	Time that has passed since the last time device's Meterbody Temperature has passed above the value of "SV Upper Stress Limit" (in days, hours and minutes).
		Set-up	None.
		NVM	Backup once each 8 hour period

Table 18 – Minimum SV Tracking

Min SV Limit	Parameter	Description	Meterbody Temperature (SV) lower operating limit from specification.
		Set-up	None.
Min SV Value	Parameter	Description	Lowest Meterbody Temperature ever experienced by the device.
		Set-up	None - value initialized to Max SV Limit value prior to leaving the factory. Updates to current Meterbody Temperature automatically when powered at user site after one minute.
		NVM	Update after every 8 hours.
Time Below Lower Stress Limit	Parameter	Description	Accumulation of minutes that device's Meterbody Temperature has been below the value of "SV Lower Stress Limit".
		Set-up	None.
		NVM	Backup once each 8 hour period
Time Since Last SV Down	Method	Description	Time that has passed since the last time device's Meterbody Temperature has passed below the value of "SV Lower Stress Limit" (in days, hours, and minutes).
		Set-up	None.
		NVM	Backup once each 8 hour period

8.2.4 TV Tracking Diagnostics

Table 19 – TV Tracking Diagnostics

Max TV Limit	Parameter	Description	Static Pressure upper operating limit specification. Units are always PSI (pounds per square inch).
		Set-up	None.
Max TV Value	Parameter	Description	Highest SP ever experienced by the device. Units are always PSI (pounds per square inch).
		Set-up	None.
		NVM	Backup once each 8 hour period
Time Above Upper Stress Limit	Parameter	Description	Accumulation of minutes that device's SP has been above the value of "SP Upper Stress Limit".
		Set-up	None.
		NVM	Backup once each 8 hour period
Time Since Last TV Up	Method	Description	Time that has passed since the last time device's SP has passed above the value of "SP Upper Stress Limit" (in days, hours, and minutes).
		Set-up	None.
		NVM	Backup once each 8 hour period

8.2.5 ET Tracking Diagnostics

Table 20 – Maximum ET Diagnostics

Max ET Limit	Parameter	Description	Electronics Temperature (ET) upper operating limit from specification. Units are same degree units as has been selected for SV (Secondary Variable).
		Set-up	None.
ET Upper Limit for Stress Condition		Description	Actual limit used in "Time Above Limit" and "Time Since Last Event". Value is equal to "Max ET Limit" less 10% of limits range.
		Example	Electronics Temperature range is -40°F to 185°F for a total of 225°F. "ET Upper Stress Limit" = 185°F - 10% of 225°F = 162.5°F.
		Set-up	None – calculation is automatic.
Max ET Value	Parameter	Description	Highest Electronics Temperature ever experienced by the device. Units are same degree units as has been selected for SV (Secondary Variable).
		Set-up	None.
		NVM	Update every 8 hour.
Time Above Upper Stress Limit	Parameter	Description	Accumulation of minutes that device's Electronics Temperature has been above the value of "ET Upper Stress Limit".
		Set-up	None.
		NVM	Backup once each 8 hour period

Time Since Last ET Up	Method	Description	Time that has passed since the last time device's Electronics Temperature has passed above the value of "ET Upper Stress Limit" (in days, hours and minutes).
		Set-up	None.
		NVM	Backup once each 8 hour period

Table 21 – Minimum ET Diagnostics

Min ET Limit	Parameter	Description	Electronics Temperature (ET) lower operating limit from specification. Units are same degree units as has been selected for SV (Secondary Variable).
		Set-up	None.
ET Lower Limit for Stress Condition		Description	Actual limit used in "Time Below Limit" and "Time Since Last Event". Value is equal to "Min ET Limit" plus 10% of limits range.
		Example	Electronics Temperature range is -40°C to 85°C for a total of 125°C. "ET Lower Stress Limit" -40°C + 10% of 125°C = -27.5°C.
		Set-up	None – calculation is automatic.
Min ET Value	Parameter	Description	Lowest Electronics Temperature ever experienced by the device. Units are same degree units as has been selected for SV (Secondary Variable).
		Set-up	None.
		NVM	Update every 8 hour.
Time Below Lower Stress Limit	Parameter	Description	Accumulation of minutes that device's Electronics Temperature has been below the value of "ET Lower Stress Limit".
		Set-up	None.
		NVM	Backup once each 8 hour period
Time Since Last ET Down	Method	Description	Time that has passed since the last time device's Electronics Temperature has passed below the value of "ET Lower Stress Limit" (in days, hours, and minutes).
		Set-up	None.
		NVM	Backup once each 8 hour period

8.2.6 % Stress Life

% Stress Life	Parameter	Description	Percent of service life spent in stressful conditions. Indicates the % of service life where one or more of PV, static pressure, meter body temperature or electronics temperature are within 10% of respective range limits.
		Set-up	None.
		NVM	Backup once each 8 hour period

8.2.7 % Service Life

% Service Life	Parameter	Description	Percent of expected Service Life that device has been in service. Value is based on electronics temperature. Service life accumulates faster at higher temperatures with an exponential relationship.
		Set-up	None.
		NVM	Backup once each 8 hour period

8.2.8 Operating Voltage Diagnostics

Table 22 – Operating Voltage Diagnostics

Current Op Voltage	Parameter	Description	Operating voltage available at device terminals.
		Set-up	None – units always in volts.
		NVM	none
		Note	No accuracy is specified for this measurement! This value is intended to be used for informational purposes only and should not be used for control.
Min Op Voltage	Parameter	Description	Minimum operating voltage experienced by device at terminals since last reset of operating voltage parameters.
		Set-up	User can reset as desired using method described in item below.
		NVM	Backup once each 8 hour period
Time Since Last Voltage Low	Method	Description	Displays time since last minimum operating voltage event in minutes.
		Set-up	User can reset as desired using method described in item below.
		NVM	Update every 8 hour.
Reset Operating Voltage Parameters	Method	Description	Causes “Min Op Voltage” to be set to 32 volts and “Time Since Last Event” to be reset to zero. Within a short period of time “Min Op Voltage” will assume operating voltage value.
		Set-up	User actuates as desired.

8.2.9 AVDD Tracking Diagnostics

Table 23 – Maximum and Minimum AVDD Tracking

Max AVDD	Parameter	Description	Maximum Sensor Supply Voltage experienced by device since last reset of voltage parameters.
Time since last AVDD Up	Method	Description	Displays time since last Sensor Supply Voltage was above last Max AVDD
Min AVDD	Method	Description	Minimum Sensor Supply voltage experienced by device since last reset of voltage parameters.
Time since Last AVDD Down	Method	Description	Displays time since last Sensor Supply Voltage was below last Min AVDD

8.2.10 Sensor CPU Temperature Tracking Diagnostics

Table 24 – Maximum Sensor CPU Temperature Tracking

Max Sensor CPU Temp.	Parameter	Description	Maximum Sensor CPU Temperature experienced by device
		Set-up	none
Time Above Upper Stress Limit	Parameter	Description	Accumulation of minutes that Sensor CPU Temperature has been above the value of Max Sensor CPU Temp.
		Set-up	None.
		NVM	Backup once each 8 hour period
Time Since Last Sensor CPU Temp. Up	Method	Description	Time that has passed since the last time Sensor CPU Temp. has passed above the value of “Max Sensor CPU Temp” (in days, hours and minutes).
		Set-up	none
		NVM	Backup once each 8 hour period

Table 25 – Minimum Sensor CPU Temperature Tracking

Min Sensor CPU Temp.	Parameter	Description	Minimum Sensor CPU Temperature experienced by device
		Set-up	none
Time Below Upper Stress Limit	Parameter	Description	Accumulation of minutes that Sensor CPU Temperature has been below the value or Min Sensor CPU Temp.
		Set-up	none
		NVM	Backup once each 8 hour period
Time Since Last Sensor CPU Temp. Down	Method	Description	Time that has passed since the last time Sensor CPU Temperature has passed below the value of “Min Sensor CPU Temp” (in days, hours and minutes).
		Set-up	none
		NVM	Backup once each 8 hour period

8.2.11 Power Up Diagnostics

Table 26 – Power Up Diagnostics

Pwr fail counter	Parameter	Description	Total number of power-ups experienced by the unit.
		Set-up	None – initialized to zero prior to leaving factory.
		NVM	Backup once each 8 hour period
		Note	Only one power failure in each 8 hour period is counted.
Time since last power fail	Method	Description	Displays time since last power-up in minutes.
		Set-up	None.
		NVM	Backup once each 8 hour period–

9 Troubleshooting and Maintenance

Table 27 lists both critical and non-critical (warning conditions) diagnostics.

9.1 HART Diagnostic Messages

Table 27 critical and non-critical HART diagnostic messages.

Table 27 – HART Diagnostic Messages

Critical Diagnostics (Failure Conditions)	Non-Critical Diagnostics (Warning Conditions)
Sensor Comm Timeout	No DAC Compensation
Meter Body Critical Failure	No Factory Calibration
Electronic Module Diag Failure	PV Out of Range
Config Data Corrupt	Fixed Current Mode
Meter Body NVM Corrupt	Sensor Over Temperature
Electronic Module DAC Failure	Meter Body Excess Correct
	Electronic Module Comm Failure
	Local Display
	Low Supply Voltage
	No DAC Calibration
	Tamper Alarm
	Meter Body Unreliable Comm
	Loop Current Noise
	AO Out of Range
	URV Set Err. Span Config Button
	LRV Set Err. Zero Config Button

9.2 HART Diagnostic Details

Table 28 lists and describes the HART critical and non-critical HART diagnostic details.

Table 28 – HART Critical and Non-Critical Diagnostic Details

Status Type	Device Status (HART Command 48)	Details/Resolutions
<p>Critical Status (Failure) <i>(continued)</i></p> <p><i>(continued)</i> Critical Status (Failure)</p>	Sensor Comm Timeout	<p>Possible causes: No response from the Sensor</p> <p>Resolution: Try replacing the Electronics module. If this does not fix the problem, replace the Meter Body.</p>
	Meter body Critical Failure	<p>Possible causes: Critical failure reported at the Sensor level</p> <p>Resolution: Reset the device. If the problem persists, replace the Meter Body.</p>
	Electronic Module Diag Failure	<p>Possible causes: Critical failure reported for the Electronics Module</p> <p>Resolution: Reset the device. If the problem persists, replace the Electronics Module.</p>
	Meter Body NVM Corrupt	<p>Possible causes: Meter Body NVM Data has been corrupted.</p> <p>Resolution: Reset the device. If the problem persists, replace the Meter Body.</p>
	Electronic Module DAC Failure	<p>Possible causes: The Electronics Module has failed. This is due to one or more of the following DAC failure conditions:</p> <ul style="list-style-type: none"> • The Electronics Module board temperature is above 140C • Under-current or Over-current Status • Packet Error, SPI Fault or Control Word Write Fault <p>Resolution: Verify the environment temperature is within spec. Reset the device. If problem persists, replace the Electronics Module.</p>

Non critical status (Warning) <i>(continued)</i>	No DAC Compensation	<p>Possible causes: No temperature compensation data exists for analog output calculations. Loop accuracy may be slightly compromised.</p> <p>The effect will be a minor degradation of ambient temperature influence specifications.</p> <p>Resolution: Replace Electronics Module (PWA) to achieve the maximum current loop accuracy or return the device to factory for DAC compensation.</p>
	No Factory Calibration	<p>Possible causes: Factory Calibration is missing. Accuracy will be compromised.</p> <p>Resolution: Replace the Meter Body or return the device for Factory Calibration.</p>
	PV Out of Range	<p>Possible causes:</p> <ul style="list-style-type: none"> • Sensor Overload/Sensor Fault • Redundant Characterization Calculation Error • Calculated pressure is above Upper Transducer Limit (UTL). <p>Resolution: Check range and, if required, replace transmitter with one that has a wider range. Meter Body may have been damaged. Check the transmitter for accuracy and linearity. Replace Meter Body and recalibrate if needed.</p>
	Fixed Current Mode	<p>Possible causes: Output current is fixed and not varying with applied input. Loop current mode is disabled or Loop Test is active.</p> <p>Resolution: Enable Loop Current Mode if it is disabled or exit the Loop Test mode if active.</p>
	Sensor Over Temperature	<p>Possible causes: Meter Body temperature is too high. Accuracy and life span may decrease if it remains high.</p> <p>Resolution: Verify the environment temperature is within specification. Take steps to insulate Meter Body from temperature source.</p>
<i>(continued)</i> Non-critical status (Warning)	Meter Body Excess Correct	<p>Possible Causes: ZERO or SPAN correction factor is outside acceptable limits. INPUT may have been incorrect during calibration or transmitter was in output mode during a CORRECT procedure.</p>

<p>(continued) Non critical status (Warning)</p>		<p>Resolution: Check input pressure and be sure that it matches calibrated range values (LRV and URV). Check Meter Body. Perform an LRV or ZERO CORRECT procedure followed by a URV CORRECT procedure.</p>
	Electronic Module Comm Failure	<p>Possible causes: There was a failure in the Electronics Module communication section.</p> <p>Resolution: Verify the environment temperature is within specifications. Reset the device. If the problem persists, replace the Electronics Module.</p>
	Display Failure	<p>Possible causes: The Display has been disconnected or configuration data has been corrupted.</p> <p>Resolution: Secure Display connections and recheck. If problem persists, reset the device. If the problem still persists, replace the Display</p>
	Low Supply Voltage	<p>Possible causes: The supply voltage to the transmitter terminals is too low or the supply voltage to the Sensor board is too low.</p> <p>Resolution: Check that the power supply and loop resistance are within specification. If possible, try to increase the voltage level of the supply. If supply voltage and loop resistance are adequate and the problem persists, replace the Electronics Module. If the problem still persists, replace the Meter Body.</p>
	No DAC Calibration	<p>Possible causes: No DAC calibration has been performed on the device.</p> <p>Resolution: Perform DAC calibration for precise analog output measurement.</p>
	Tamper Alarm	<p>Possible causes: Device is in Write Protect Mode and Tamper Mode is enabled, or Tamper Alarm alone is enabled, and outside attempts to change device configuration exceeded the set Tamper limit</p> <p>Resolution: Identify source of tampering. If configuration changes are required, contact a qualified individual to unlock the Write Protection Mode feature and disable the Tamper Mode and make the required updates.</p>

	Meter Body Unreliable Comm	<p>Possible causes: Either the transmitter is installed in a noisy environment or internal communication quality between the Electronics Module and Sensor is degrading.</p> <p>Resolution: Call service person.</p>
	Loop Current Noise	<p>Possible causes: If this is observed frequently, it is an early indication of critical under/over-current failure.</p> <p>Resolution: Closely monitor the device status for indications of other failures, or proactively replace the Electronics module.</p>
	AO Out of Range	<p>Possible causes: Calculated Analog output is either above or below the specified Loop Current Limits. The transmitter input is not in specified range.</p> <p>Resolution: Check the transmitter input and verify the configured operating range.</p>
	URV Set Err. Span Config Button	<p>Possible causes: SET URV operation using external Span button was rejected.</p> <p>Resolution: Verify the inputs are valid for the intended operation.</p>
	LRV Set Err. Zero Config Button	<p>Possible causes: SET LRV operation using external Zero button was rejected.</p> <p>Resolution: Verify the inputs are valid for the intended operation.</p>

9.3 DE Diagnostic Messages

Table 29 lists and describe DE diagnostics.

Table 29 – DE Diagnostics

Diagnostics Type	Diagnostics	Details/Resolution
Critical <i>(continued)</i>	NVM fault	Possible causes: The NVM in the Sensor board is corrupt The NVM in the Electronics module is corrupt Resolution: Reset the device. If the problem persists, replace the Meter Body.
	RAM fault	Possible causes: The RAM in the Sensor board is corrupt The RAM database in the Sensor board is compromised Resolution: Reset the device. If the problem persists, replace the Meter Body.
	MDU/DAC compensation fault	Possible causes: This status is caused by one of the following problems: <ul style="list-style-type: none"> • DAC SPI fault • DAC PEC fault • DAC Temperature above 140C • DAC VLOOP (loop voltage)low • DAC control word write fault Resolution: Verify the environment temperature is within specification. Take steps to insulate Meter Body from temperature source. If problem persists, replace Electronics Module.
	Suspect input	Possible causes: Pressure, Meter Body Temperature and/or Static Pressure input are extremely out of range such that the value is suspect. Resolution: Verify that all inputs are within specifications. Reset the device. If the problem persists, replace the Meter Body.
	Characterization prom fault or bad checksum	Possible causes: Sensor characterization is corrupt or there is a Sensor firmware failure Resolution: Reset the device. If the problem persists, replace the Meter Body.
Meter body failure	Possible causes: <ul style="list-style-type: none"> • Meter body failure • Sensor communication timeout • Sensor firmware flow failure 	

Diagnostics Type	Diagnostics	Details/Resolution
<i>(continued)</i> Critical		Resolution: Reset the device. If the problem persists, replace the Meter Body.
Non-Critical <i>(continued)</i>	No DAC Compensation	Possible causes: No temperature compensation data exists for analog output calculations. Loop accuracy may be slightly compromised. Effect will be minor degradation of ambient temperature influence specifications. Resolution: Replace Electronics Module (PWA) to achieve the maximum current loop accuracy or return the device to factory for DAC compensation.
	Reset Corrects Flag	Successful "Reset Corrects" operation will set this flag and display message as "Calibration Correction values are reset to factory default". When 'LRV Correct' and 'URV Correct' operations are performed, the flag will be reset.
	Sensor Fault	Possible causes: <ul style="list-style-type: none"> • There is a failure on the Sensor Board • Redundant Characterization Calculation Error • Calculated pressure is above Upper Transducer Limit (UTL). Resolution: Check range and, if required, replace transmitter with one that has a wider range. Meter Body may have been damaged. Check the transmitter for accuracy and linearity. Replace Meter Body and recalibrate if needed.
	Sensor overload	Possible causes: The calculated pressure is above the Upper Transducer Limit (UTL). Resolution: Check range and, if required, replace transmitter with one that has a wider range. Meter Body may have been damaged. Check the transmitter for accuracy and linearity. Replace Meter Body and recalibrate if needed.
	Current Fixed	Possible causes: Output current is fixed and not varying with applied input. Output Mode is active. Resolution: Exit Output mode if active.
	Excess Span Correction	The SPAN correction factor is outside acceptable

Diagnostics Type	Diagnostics	Details/Resolution
<p><i>(continued)</i> Non-Critical</p>		<p>limits. INPUT may have been incorrect during calibration or transmitter was in output mode during a URV CORRECT procedure.</p> <p>Resolution: Check input pressure and be sure that it matches calibrated range values (LRV and URV). Check Meter Body. Perform an LRV or ZERO CORRECT procedure followed by a URV CORRECT procedure.</p>
	<p>Excess Zero Correction</p>	<p>The ZERO correction factor is outside acceptable limits. INPUT may have been incorrect during calibration or transmitter was in output mode during an LRV or ZERO CORRECT procedure.</p> <p>Resolution: Check input pressure and be sure that it matches calibrated range values (LRV and URV). Check Meter Body. Perform an LRV or ZERO CORRECT procedure followed by a URV CORRECT procedure.</p>
	<p>Sensor Over Temperature</p>	<p>Possible causes: Meter Body temperature is too high. Accuracy and life span may decrease if it remains high.</p> <p>Resolution: Verify the environment temperature is within specification. Take steps to insulate Meter Body from temperature source.</p>

10 Using DTMs

10.1 Introduction

ST 700 HART and Fieldbus models support DTMs running on Pactware or FDM / Experion. To set up the DTM network on the FDM/Experion, refer to the *FDM/Experion User Guide*. In this manual, the procedure is given to run the ST 700 HART DTM on Pactware (Version 4.1 or above).

10.2 Components

In order to be able to use the HART DTM you need the following:

- PACTware or some other Container application.
- Microsoft .NET Framework
- Latest HART Communication DTM: Free version of HART Communication DTM available for download from CodeWrights website.
- Honeywell HART DTM Library
- Viator modem from MacTek: RS-232 interface for HART Networks

10.3 Downloads

- **Download 1:** Pactware 4.x and .NET 2.0
Download from www.pactware.com
- **Download 2:** HART Communication DTM\
Download from <http://www.codewrights.biz/>
- **Download 3:** Honeywell HART DTM Library
Download from HPS web site

10.4 Procedure to Install and Run the DTM

1. Install the Download 1, 2, or 3 above.
2. Connect the Transmitter to the 30 V DC power supply with a 250 ohm loop resistor.
3. Connect the Viator modem terminals to the Transmitter power terminals.
4. Connect the Viator modem DB9 connector to the PC COM port.
5. Run Pactware. Select Update Device Catalog before adding Device (before adding HART Comm DTM).
6. Add Device – Add HART Comm DTM.
7. Right click on HART DTM, select Connect.
8. Right Click on HART Comm DTM and select Add device.
9. Add the Device DTM from for your device from the list (for example: ST 700 DevRev 1).
10. Right Click on Device DTM, and select Connect.
11. Right click on Device DTM, and select Parameter/online parameterization. You should see Status “Connected” to be able to do configuration, calibration etc.
12. Browse through the menus to access various parameters/functions

The following sections provide a high level overview of ST 700 DTM screens. The Menu structure is similar to the MC Toolkit FDC application and behavior of the parameters / methods is the same as the MC Toolkit FDC application. Refer to Table 11 for a complete listing of all the parameters and details. In the following sections, emphasis is given to show the various DTM screens.

10.5 ST 700 Online Parameterization

On selecting Parameter/Online Parameterization, the DTM home page is displayed as shown below.

The screenshot displays the Field Device Manager (FDM) interface, connected to WXP-BASE. The main window title is "Field Device Manager - Connected to WXP-BASE". The interface includes a menu bar (FDM, View, Tools, Library, Windows, Help) and a search bar (Search Device: [] Advanced Search). The device name is "ST_700_R_ConflictTag_F14". The DTM Start Page is selected, and the Online Parameterize option is active. The device details are as follows:

Model:	PV:
ST 700	-17.07 mbar

Tag:	PV AO:
	7.32699 mA

The Device Health section shows a Warning icon and a Device Status button. The Process Variables section includes three meters:

- PV Meter:** -17.07 mbar
- SV Meter:** 3.91 degC
- AO Meter:** 7.327 mA

Additional parameters are displayed below the meters:

Parameter	Value
PV	-17.07 mbar
ET	51.54 degC
PV LRV	-50 mbar
SV	3.91 degC
PV %	20.79 %
PV LRV	50 mbar
PV AO	7.327 mA
TV	2986.536 psi

The Shortcuts section includes buttons for Device Setup, Basic Setup, and Calibration.

10.5.1 Device Health:

Shows Overall Device Status Image and “Device Status” Button/Link that takes you to the Device Status screen.

Overall Device Status will be either Normal, Warning or Failure depending upon the health of the device:



Overall Device Status will be shown on each of the DTM pages so that the user can get the current status of the device from any screen

10.5.2 Device Icon / Honeywell Logo:

Shows the Honeywell Logo, Transmitter icon.

10.5.3 Process Variables:

Shows Primary variables Gauges and their values, LRV, URV.

10.5.4 Shortcuts:

Device Setup:

- Provides Tabs to access any of the functions : Basic Setup, Calibration, Process Variables, Device Status, Diagnostics, Services, Detailed Setup, Meter Body Selections, Display Setup and Review

Basic Setup:

- Provides Device Setup information (Tag, Device Type, MB Type etc.)

Calibration:

- Provides access to all the Calibration functions



Refer to the Table 11 for more details

10.6 Basic Setup Page

SDC 625 - [Device Setup]

Device View Window Help

Basic Setup Calibration Process Variables Device Status Diagnostics Services Detailed Setup Meterbody Selections Display Setup Review

Device Health

Normal

Pressure Xfer Fn

PV Xfer Inctn Linear

Linear

Output %

Input (% of Span)

Low Flow Cutoff (Sq Root)

Low Flow Cutoff Mode User Config

Low Flow Cutoff Bkpt(User Config) 0 %

Device Information

Range values

Manufacturer Honeywell

Model ST 800

Install Date 01/01/1900

MB Type DP

MB ID ??????????

Tag ??????????

Long tag ??????????????????

Cfg chng count 1

Date 01/01/1900

Descriptor ??????????????????

Message ??????????????????

Clear Message

Maint Mode Chk with oper

Dev id 1

Final asmbly num 1

Universal rev 7

Fld dev rev 1

Software rev 1

Loop mA Disabled

PV Units inH2O

PV Damping 0.00 s

SV Units degC

Write Protect No

Model Number

“Transmitter Messaging” and “Maintenance Mode”

10.6.1 Pressure Transfer Fn:

Allows selecting Transfer function; Linear or Square Root.

10.6.2 Low Flow Cutoff Mode:

Allows selecting the User Config Mode and entering the Low Flow Cutoff breakpoint from 0-25% to get the needed signal conditioning. Refer to Table 11 for more details

10.6.3 Device Information

Allows access to both read only parameters and read/write parameters. Provides access to Message, Clear Message and Maint Mode.



Refer to Table 11 for more details

10.6.4 Model Number:

Shows the Model number.

10.6.5 Device Assembly:

Shows the Blow out Image of ST 700

10.6.6 System Setup:

Shows the Image how to connect the Transmitter

10.7 Calibration Page

The Calibration Page provides access to all of the calibration methods and records.

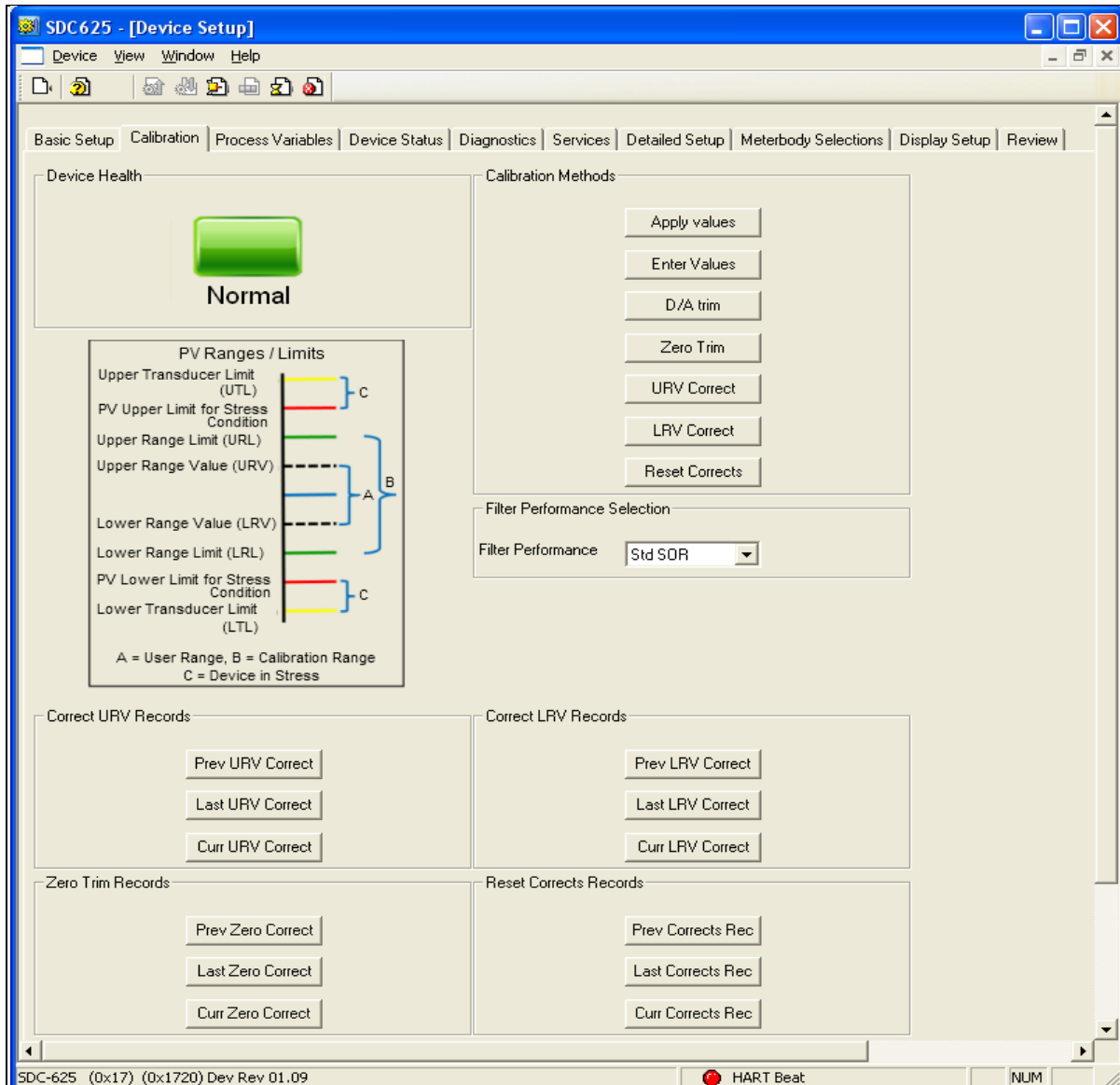

10.7.1 Calibration Methods

- Apply Values
- Enter Values
- D/A Trim
- Zero Trim
- URV Correct
- LRV Correct
- Reset Corrects



Refer to Table 11 for more details

10.7.2 Calibration Records

Correct URV Records

- Prev URV Correct
- Last URV Correct
- Curr URV Correct



Refer to the Calibration Records in [for more details](#)

Correct LRV Records

- Prev LRV Correct
- Last LRV Correct
- Curr LRV Correct



Refer to the Calibration Records in [for more details](#)

Zero Trim Records

- Prev Zero Trim
- Last Zero Trim
- Curr Zero Trim



Refer to the Calibration Records in [for more details](#)

Reset Corrects Records

- Prev Corrects Resets
- Last Corrects Resets
- Curr Corrects Resets



Refer to the Calibration Records in [for more details](#)

10.8 Process Variables

All the Process Variables are graphically represented in this screen. Select Trend Charts to see the Trending Charts

The screenshot displays the 'Field Device Manager - Connected to WXP-BASE' interface. The main window shows the 'Process Variables' tab for device 'ST 700 R_ConflictTag_F14'. The device information includes Model: ST 700, Tag: , PV: -17.06 mbar, and PV AO: 7.32635 mA. The interface features several meters and a bar chart:

- PV Meter:** Pressure meter showing -17.06 mbar.
- SV Meter:** Temperature meter showing 3.90 degC.
- AO Meter:** Current meter showing 7.326 mA.
- ET Meter:** Temperature meter showing 50.89 degC.
- TV Meter:** Pressure meter showing 2986.110 psi.
- PV AO %:** Bar chart showing 20.79%.

A callout box with the text 'Select to see the Trending Charts' points to a 'Trend Charts' button located near the SV Meter.

10.9 Trend Charts

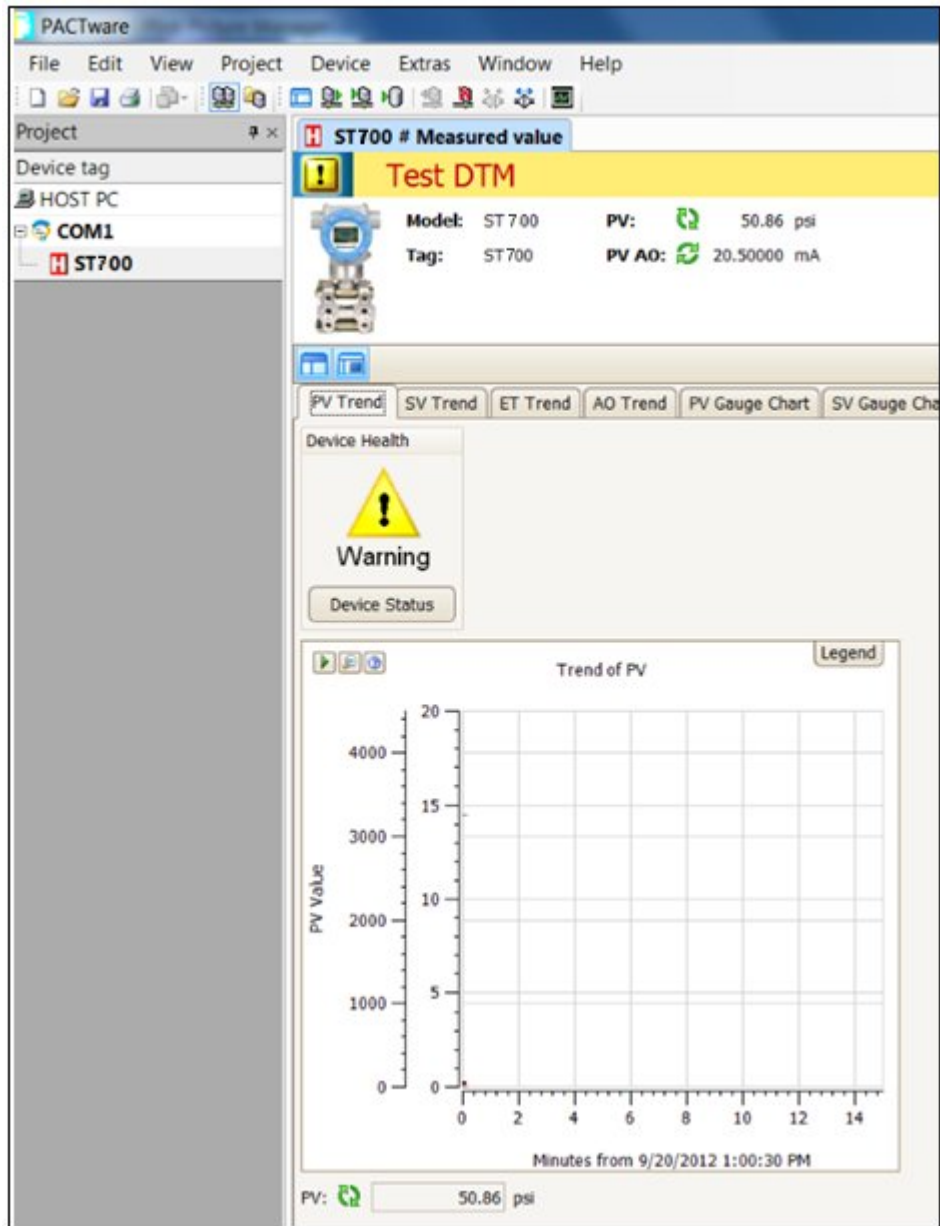

10.10 Device Status

Shows Critical and Non-Critical status and context-sensitive help when gliding the mouse over an individual status.

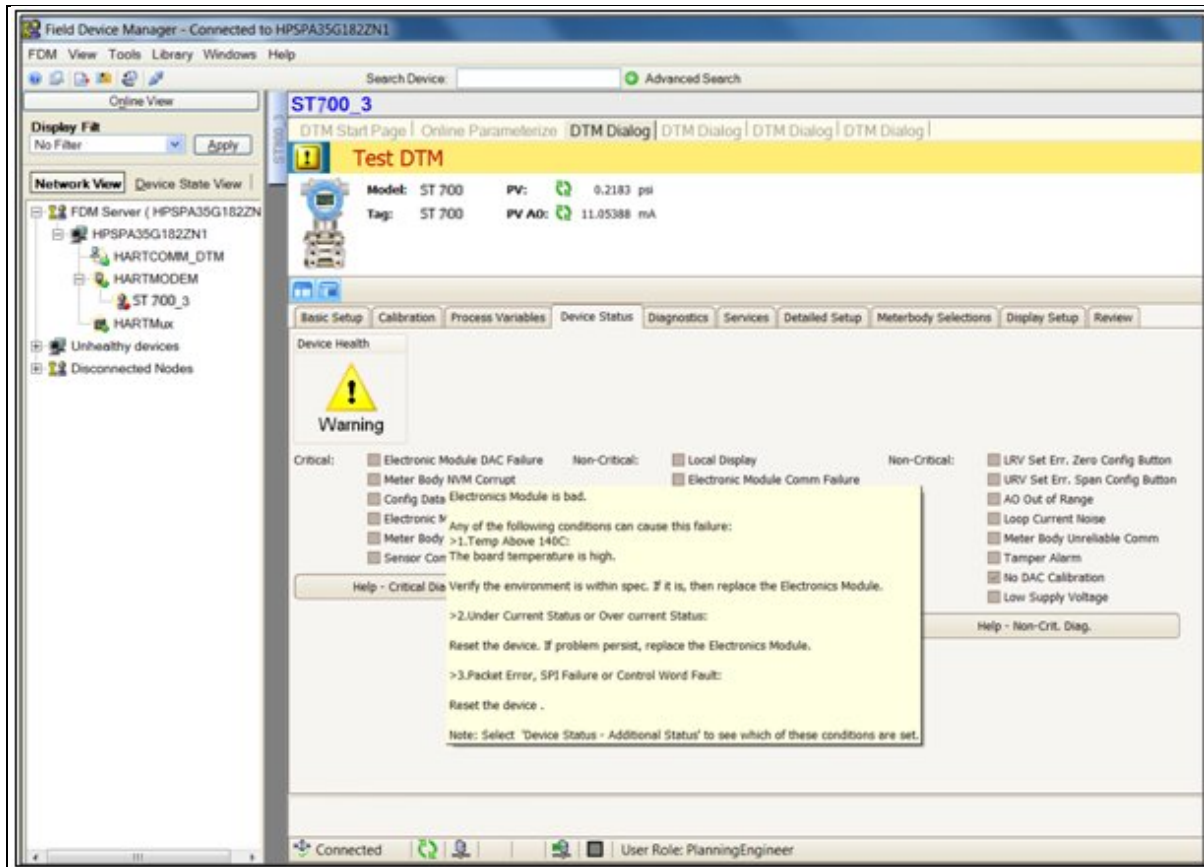

Refer "Troubleshooting and Maintenance" for more details on individual status details

10.11 Critical and Non-Critical Help Display

Shows Help on Critical, Non-Critical when you click on “Help – Critical Diag” or “Help – Non-Critical Diag” buttons. Also, extended status can be seen by clicking the “Additional Status” button.

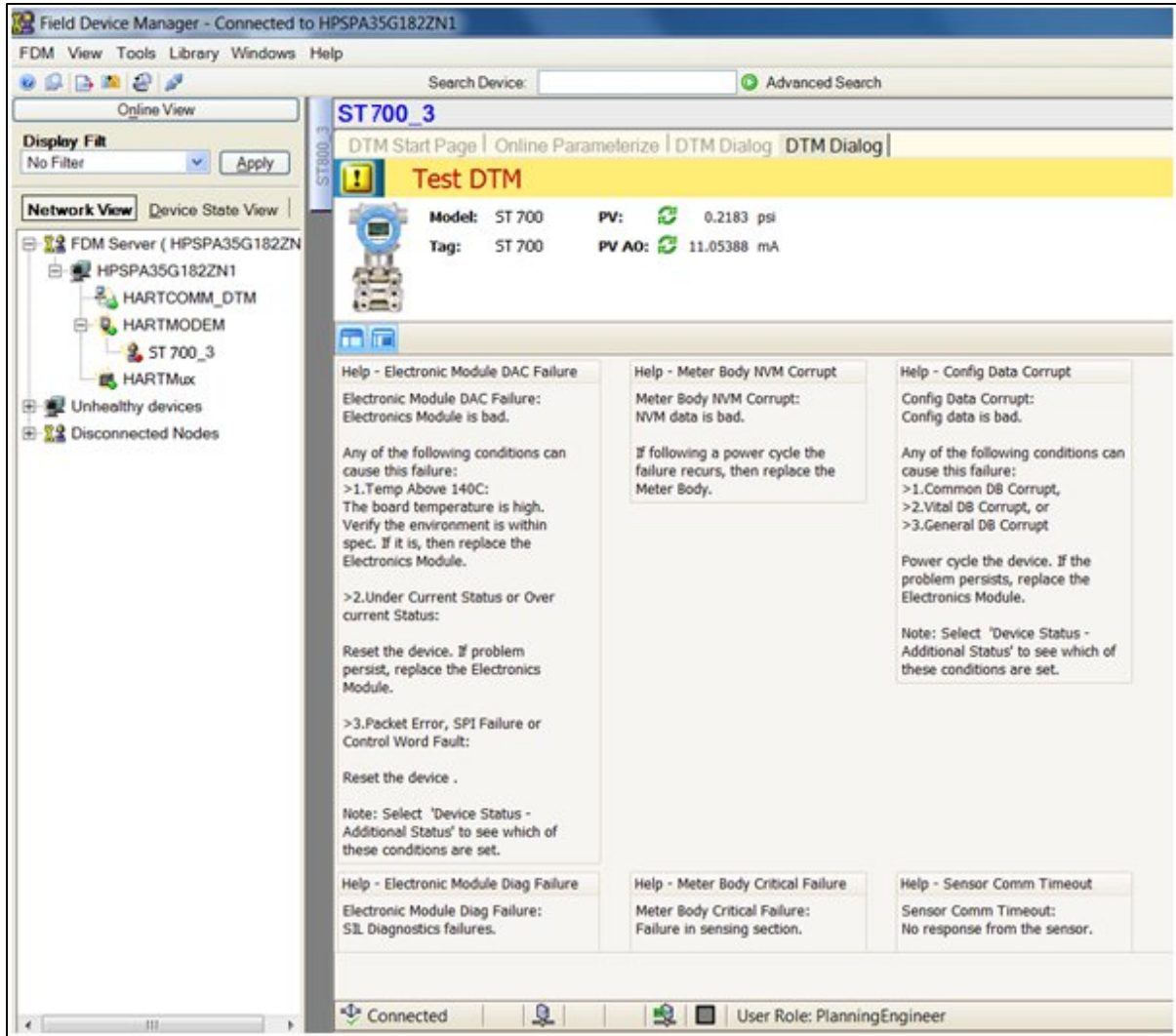

10.12 Diagnostics:

Provides access to the Advanced Diagnostics and Config History functions:

Various Advanced Diagnostics:

- Installation and Device Life
- PV Tracking
- SV Tracking
- ET Tracking
- Operating Voltage
- AVDD Tracking
- Sensor CPU Temp. Tracking
- Power Up Diagnostics

Access the relevant tab to read the Diagnostic parameters or run the Diagnostics Methods



Refer "HART Advanced Diagnostics" section for more details.

The screenshot displays the Field Device Manager interface for an ST 700 device. The main window shows the following information:

- Device Information:** Model: ST 700, PV: 91.67 psi, Tag: ST8, PV AD: 20.80000 mA.
- Tracking Variables:** A graph showing PV tracking with labels for Max Var Value, Min Var Value, U1, U2, L1, L2, and M1. A legend explains: Vu: Upper Limit for Stress Condition, Vt: Lower Limit for Stress Condition, U1, U2: Time above Upper Stress Limit, L1, L2: Time below Lower Stress Limit, M1: Method Execution Point.
- Diagnostic Parameters:**
 - UTL: 1.5e+04 psi
 - Max PV: -36125.96 psi
 - Time Above Upper Stress Limit: 0 minutes
 - PV Upper Limit For Stress Condition
 - Time Since Last PV Up
 - LTl: 0 psi
 - Min PV: 36125.96 psi
 - Time Below Lower Stress Limit: 0 minutes
 - PV Lower Limit For Stress Condition
 - Time Since Last PV Down

10.13 Services

This allows configuration of Tamper Alarm and Write Protect mode.



Refer “Device Configuration and Parameter Descriptions” for more details.

Field Device Manager - Connected to HPSPA35G182ZN1

FDM View Tools Library Windows Help

Search Device: [] Advanced Search

Online View

Display Filter: No Filter [Apply]

Network View Device State View

FDM Server (HPSPA35G182ZN1)

- HPSPA35G182ZN1
 - HARTCOMM_DTM
 - HARTMODEM
 - ST 700_3
 - HARTMux
- Unhealthy devices
- Disconnected Nodes

ST700_3

DTM Start Page | Online Parameterize | DTM Dialog | DTM Dialog | DTM Dialog

Test DTM

Model: ST 700 PV: 0.2183 psi
Tag: ST 700 PV AD: 11.05388 mA

Basic Setup Calibration Process Variables Device Status Diagnostics Services Detailed Setup Meterbody Selections Display Setup Review

Device Health

Warning

Device Status

Tamper Mode: Disable [Master Reset]
Attempt Counter: 0 [Loop test]
Tamper Latency: 1 [Lock/Unlock Device]
Max Attempts: 3 [Configure Tamper Alarm]
[Reset Tamper Counter]

Write Protect: No [Write Protect Off] [Change Password]

Connected User Role: PlanningEngineer

Configuration of Tamper Alarm

10.14 Detailed Setup

Shows Sensor Limits, Output Condition, Signal Condition and Burnout level selections.

The screenshot displays the Field Device Manager (FDM) software interface for configuring an ST700 device. The main window is titled "Field Device Manager - Connected to UK-410B84R". The interface is divided into several sections:

- Network View:** Shows a tree structure of devices connected to the FDM Server (UK-410B84R), including UK-410B84R, UK-R410 SVR, C3H_05, AI_HART_01, STT25H, and ST700.
- Device Setup:** The main configuration area for the ST700 device, showing a "Warning" icon and a "Device Status" button.
- NAMUR Option:** A dropdown menu set to "Enabled".
- 4-20 mA dc Output & Failsafe Option Selections:** A diagram showing the relationship between NAMUR and Honeywell options. It includes values for HBO (High Burnout) and LBO (Low Burnout) at 21.0 mA, 20.5 mA, 20 mA, 4 mA, and 3.6 mA.
- Sensors:** A list of sensor parameters with their units and values:
 - UTL: 4500 psi
 - LTL: 0 psi
 - PV URL: 2999.98 psi
 - PV LRL: 0 psi
 - PV: -0.0148 psi
 - PV unit: psi
 - SV: 33.78 de.
 - SV unit: degC
- Output Condition:** A list of output parameters with their units and values:
 - Poll addr: 0
 - Num req.: 7
 - PV AO: 20.5 mA
 - PV AO A.: H
 - Loop mA: Enabled
- Signal Condition:** A list of signal parameters with their units and values:
 - PV Dam.: 0 s
 - PV URV: 0 psi
 - PV LRV: 12 psi

The interface also includes a "Display Filter" section, a "Search Device" field, and a "Device Health" section with a warning icon. The bottom status bar shows "Device loaded successfully" and "Online System Notifications".



Refer Device Configuration and Parameter Descriptions for more details.

10.15 Meterbody Selection

Select the Meter Body Selections to see the Material of Construction details

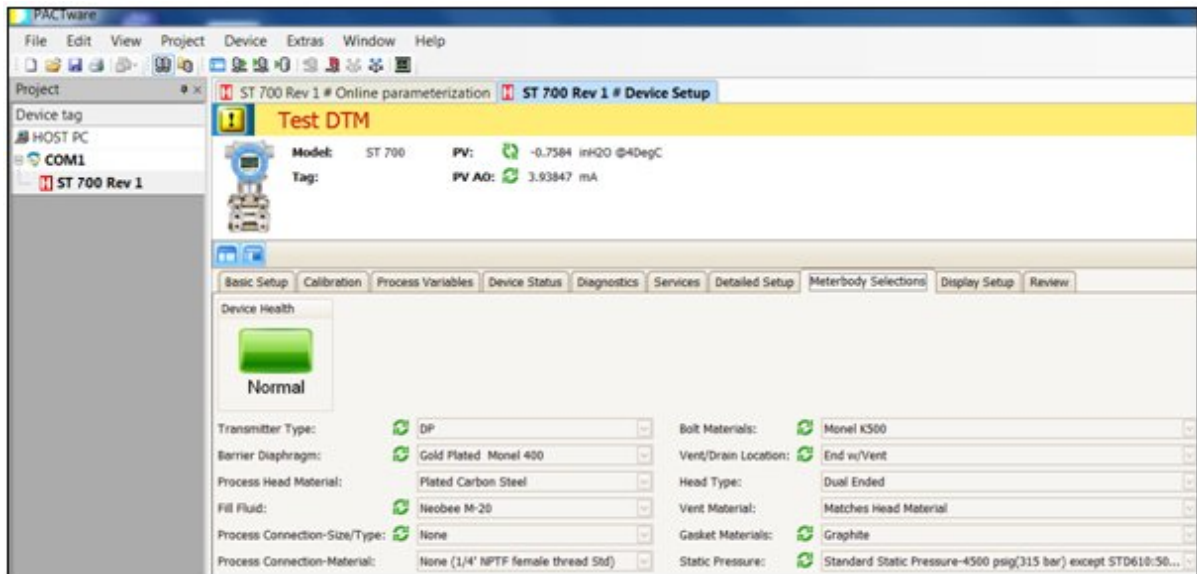

10.16 Display Setup

Allows configuring the Display from the Host.

10.17 Read Screen Info:

Select the Screen number to get the relevant screen settings information

10.18 Screen Configuration:

To configure any of the Display screens run the “Configure” Method and set to the appropriate settings. Refer to the “ST 700 SmartLine Pressure Transmitter User’s Manual” 34-ST-25-44, Basic Display Menu sections for help configuring the Display Parameters

10.19 Common setup:

This lists the Common setup for all the screens



Refer “ST 700 SmartLine Pressure Transmitter User’s Manual: 34-ST-25-44, Basic Display Menu sections” for more details.

10.20 Review

Summary screen showing all the parameters.

The screenshot displays the 'Test DTM' window in the ST 700 Device Setup software. At the top, a yellow banner indicates a 'Warning' status. Below this, the 'Device Health' section shows a yellow warning triangle icon and a 'Warning' label. The main area contains a 'Device Status' button and a comprehensive list of parameters for the ST 700 device, organized into columns. The parameters include Manufacturer (Honeywell), Model (ST 800), MB Type (GP), PV unit (psi), PV LRL (0.00 psi), PV URL (2999.98 psi), LTL (0 psi), UTL (4500 psi), PV Damp (0.00 s), PV % (187.51 %), Xfer Fnc (Sq root), PV URV (14.45 psi), and PV LRV (0 psi). Other parameters include Loop mA (Enabled), PV AO (20.500 mA), PV AO Alm Type (Hi), SV unit (degC), MB ID (53979485M6G1), Tag (ST800), Long tag (longtag), Date (1/1/1900), Descriptor (DESCR1), Message (HI THERE), Write Protect (No), Final assembly num (1), and Dev id (3979481). Additional parameters include Universal rev (2), Fld dev rev (1), Software rev (107), Display SW Version (1.01000w), MB SW Version (1.00005), Dev SW Version (1.0100ag), Poll addr (0), Cfg chng count (154), Num req preams (7), Inst Dt (1/1/1972), Pwr Fail (168), Filter Performance (Std SOR), Comm Board Stress Life (0.000000 %), and Comm Board Service Life (0.069156 %).

Manufacturer:	Honeywell	Loop mA:	Enabled	Universal rev:	2
Model:	ST 800	PV AO:	20.500 mA	Fld dev rev:	1
MB Type:	GP	PV AO Alm Type:	Hi	Software rev:	107
PV unit:	psi	SV unit:	degC	Display SW Version:	1.01000w
PV LRL:	0.00 psi	MB ID:	53979485M6G1	MB SW Version:	1.00005
PV URL:	2999.98 psi	Tag:	ST800	Dev SW Version:	1.0100ag
LTL:	0 psi	Long tag:	longtag	Poll addr:	0
UTL:	4500 psi	Date:	1/1/1900	Cfg chng count:	154
PV Damp:	0.00 s	Descriptor:	DESCR1	Num req preams:	7
PV %:	187.51 %	Message:	HI THERE	Inst Dt:	1/1/1972
Xfer Fnc:	Sq root	Write Protect:	No	Pwr Fail:	168
PV URV:	14.45 psi	Final assembly num:	1	Filter Performance:	Std SOR
PV LRV:	0 psi	Dev id:	3979481	Comm Board Stress Life:	0.000000 %
				Comm Board Service Life:	0.069156 %



Refer "Device Configuration and Parameter Descriptions " for more details.

10.21 ST 700 Offline Parameterization

On selecting Parameter/ Parameterization, the Offline parameter configuration page will be displayed.

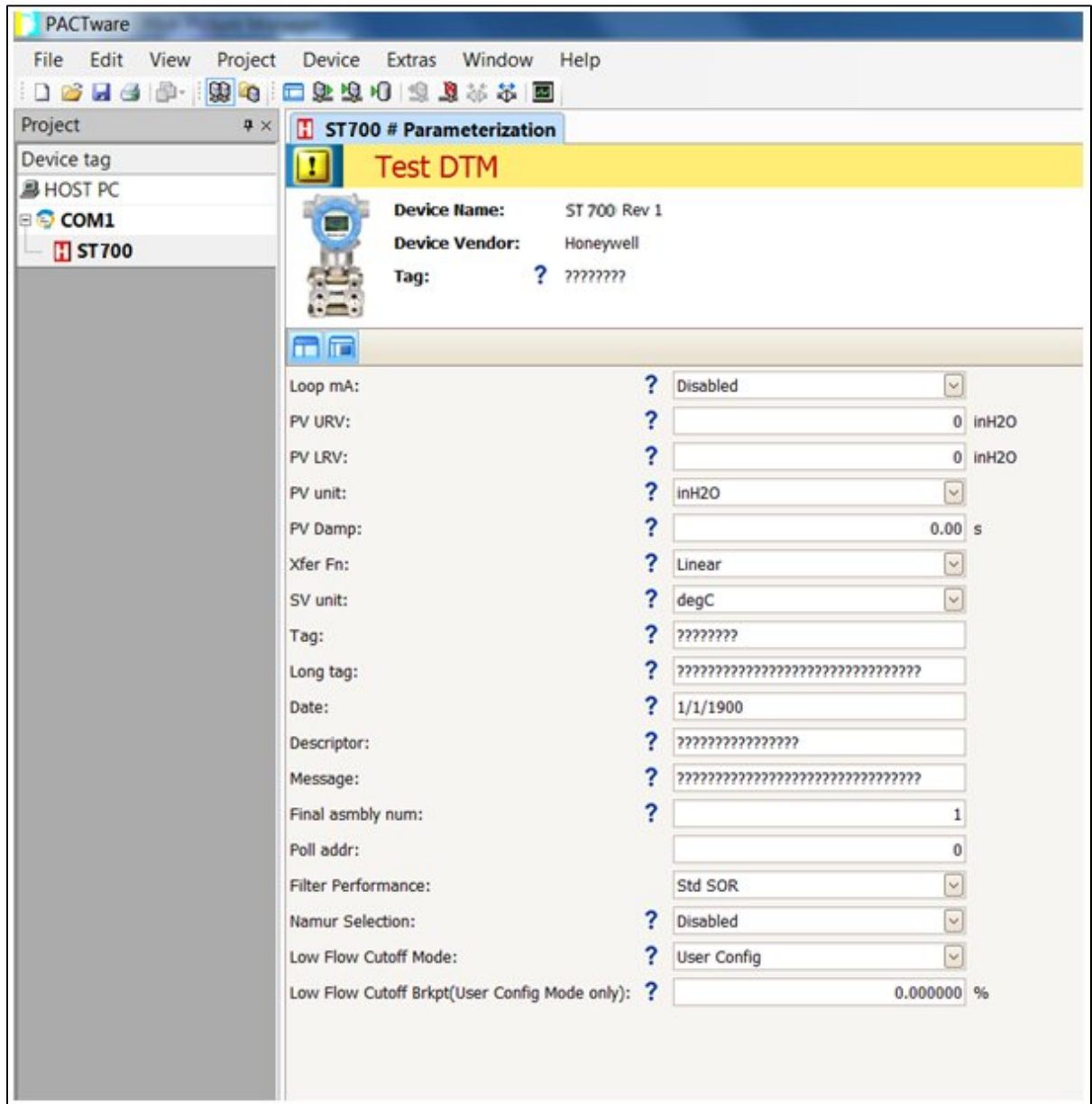

Select Device / Load to Device to download the Offline Configuration to the connected device.

11. HART DD binary file format compatibility matrix

"Host - ST 700 - HART DD binary file format" compatibility matrix	
Host	DD file format to be used
Experion R410	Fm8
Experion R400 to R300	Fm6
Experion below R300	fms
FDM R430	Fm8
FDM R410 – R302	Fm6
FDM Below R302	fms



Refer the respective Tools' User Manual for details on loading the DD file on these Tools.

Glossary

AP	Absolute Pressure
AWG	American Wire Gauge
DE	Digital Enhanced Communications Mode
DP	Differential Pressure
d1	Inside diameter of pipe
d2	Orifice plate bore diameter at flowing temperature
do	Inside diameter of orifice
EMI	Electromagnetic Interference
FTA	Field Termination Assembly
GP	Gauge Pressure
HP	High Pressure (also, High Pressure side of a Differential Pressure Transmitter)
Hz	Hertz
inH ₂ O	Inches of Water
LGP	In-Line Gauge Pressure
LP	Low Pressure (also, Low Pressure side of a Differential Pressure Transmitter)
LRL	Lower Range Limit
LRV	Lower Range Value
mAdc	Milliamperes Direct Current
mmHg	Millimeters of Mercury
mV	Millivolts
Nm	Newton meters
NPT	National Pipe Thread
NVM	Non-Volatile Memory
P	Pressure
Pa	Measured static pressure in PV4 algorithm
Pc	Absolute critical pressure of the gas
Pd	Static pressure at downstream point
Pdp	Measured differential pressure in Pascals in PV4 algorithm
Pf	Absolute pressure of flowing gas
Pr	Reduced pressure
Pu	Static pressure at upstream point
PM	Process Manger
PSI	Pounds per Square Inch
PSIA	Pounds per Square Inch Absolute

PV	Process Variable
PWA	Printed Wiring Assembly
RFI	Radio Frequency Interference
RTD	Resistance Temperature Detector
SFC	Smart Field Communicator
STIM	Pressure Transmitter Interface Module
STIMV IOP	Pressure Transmitter Interface Multivariable Input/Output Processor
URL	Upper Range Limit
URV	Upper Range Value
US	Universal Station
Vac	Volts Alternating Current
Vdc	Volts Direct Current
HART	Highway Addressable Remote Transmitter
HCF	HART Communication Foundation
EEPROM	Electrically Erasable Programmable Read Only Memory

INDEX

A	
About This Manual	iii
C	
Communication Modes	6
Digitally Enhanced (DE) Mode Communication	6
HART Mode Communication	7
Configuration Tools and Interfaces	8
Application Design, Installation, Startup, and Operation	8
MC Toolkit Participation	8, 9
Copyrights, Notices and Trademarks	ii
D	
DE Calibration	53
Analog Output Signal Calibration	53
Calibrating Range Using the MC Toolkit	55
Calibration Recommendations	53
Conditions for Input Calibration	55
DE Output Calibration	60
Input Calibration Procedure	56
Input Calibration Procedures Description	55
Manually Setting the Process Variable Range	62
Procedure to Reset Calibration	65
Test Equipment Required for Calibration	53
DE Transmitter Configuration	11
Configuration Personnel Requirements	11
DE Transmitter Offline Configuration	21
DE Transmitter Online Configuration	12
MC Toolkit Software Application Overview	11
DE Transmitter Offline Configuration	21
DE Transmitter Online Configuration	12
DE-Specific Configuration Parameters	16
Digitally Enhanced (DE) Mode Communication	6
F	
Field Device Configurator	24
aving device history	46
Custom Views	48
G	
Device Configuration and Parameter Descriptions ..	33
Exporting device history records to Documint	48
Exporting device history records to FDM	47
Manage DDs	26
Offline configuration	28
Offline Configuration	50
Online configuration	27
Overview of Device Homepage	28
Procedure to Enter the Transmitter Tag	See
Selecting the Process Variable (PV) Unit of Pressure Measurement	44
Setting PV URV, and LRV Range Values	45
Setting Range Values for Applied Pressure	45
Settings	25
Using FDC for various device operations	31
H	
Glossary	107
H	
HART Advanced Diagnostics	72
HART Calibration	67
Analog Output Signal Calibration	68
Calibrating Range	69
HART DD binary file format compatibility matrix ..	106
HART Mode Communication	7
HART Transmitter Configuration	23
Overview of FDC Homepage	24
L	
Local Display Options	4
O	
Optional 3-Button Assembly	5
R	
References	iii
Release Information	iii

S

Safety Certification Information	3
Series, Model and Number	3
ST 700 Physical and Functional Characteristics	1
Features and Options.....	1
Local Display Options	4
Optional 3-Button Assembly	5
Overview	1
Safety Certification Information	3
Series, Model and Number	3
Transmitter Adjustments	4

T

Transmitter Adjustments	4
Troubleshooting and Maintenance	81

U

Uploading a Transmitter Configuration	12
Using DTMs	89
Basic Setup Page.....	92
Calibration Page	94
Critical and Non-Critical Help Display	99
Detailed Setup	102
Device Status	98
Diagnostics	100
Display Setup	103
Downloads.....	89
Meterbody Selection	103
Procedure to Install and Run the DTM	89
Process Variables.....	96
Screen Configuration	103
Services.....	101
ST 700 Offline Parameterization.....	105
ST 700 Online Parameterization.....	90
Trend Charts.....	97

Sales and Service

For application assistance, current specifications, pricing, or name of the nearest Authorized Distributor, contact one of the offices below.

ASIA PACIFIC

(TAC)

dfs-tac-support@honeywell.com

Australia

Honeywell Limited
Phone: +(61) 7-3846 1255
FAX: +(61) 7-3840 6481
Toll Free 1300-36-39-36
Toll Free Fax:
1300-36-04-70

China – PRC - Shanghai

Honeywell China Inc.
Phone: (86-21) 5257-4568
Fax: (86-21) 6237-2826

Singapore

Honeywell Pte Ltd.
Phone: +(65) 6580 3278
Fax: +(65) 6445-3033

South Korea

Honeywell Korea Co Ltd
Phone: +(822) 799 6114
Fax: +(822) 792 9015

EMEA

Honeywell Process
Solutions,
Phone: + 80012026455 or
+44 (0)1202645583
FAX: +44 (0) 1344 655554

Email: (Sales)
sc-cp-apps-salespa62@honeywell.com
or
(TAC)
dfs-tac-support@honeywell.com

NORTH AMERICA

Honeywell Process
Solutions,
Phone: 1-800-423-9883
Or 1-800-343-0228

Email: (Sales)
ask-ssc@honeywell.com
or
(TAC)
dfs-tac-support@honeywell.com

SOUTH AMERICA

Honeywell do Brazil & Cia
Phone: +(55-11) 7266-1900
FAX: +(55-11) 7266-1905

Email: (Sales)
ask-ssc@honeywell.com
or
(TAC)
dfs-tac-support@honeywell.com

Honeywell

Honeywell Process Solutions
1860 West Rose Garden Lane
Phoenix, Arizona 85027
www.honeywellprocess.com

34-ST-25-47 Rev.1.0
February 2013
©2013 Honeywell International Inc.