

SMV 3000

Smart Multivariable Transmitter

User's Manual

34-SM-25-02

3/04

Copyright, Notices, and Trademarks

© Copyright 1999 by Honeywell Inc.

Revision 0 – January 18, 1999

While this information is presented in good faith and believed to be accurate, Honeywell disclaims the implied warranties of merchantability and fitness for a particular purpose and makes no express warranties except as may be stated in its written agreement with and for its customer.

In no event is Honeywell liable to anyone for any indirect, special or consequential damages. The information and specifications in this document are subject to change without notice.

This document was prepared using Information Mapping® methodologies and formatting principles.

TotalPlant, TDC 3000 and SFC are U.S. registered trademarks of Honeywell Inc.

SmartLine is a U.S. trademark of Honeywell Inc.

Information Mapping is a trademark of Information Mapping Inc.

Other brand or product names are trademarks of their respective owners.

Honeywell
Industrial Automation and Control
Automation College
2820 West Kelton Lane
Phoenix, AZ 85023

About This Publication

This manual is intended as a detailed “how to” reference for installing, piping, wiring, configuring, starting up, operating, maintaining, calibrating, and servicing Honeywell’s SMV 3000 Smart Multivariable Transmitter. It is based on using the SCT 3000 Smartline® Configuration Toolkit software version 2.0 or greater as the operator interface.

While this manual provides detailed procedures to assist first time users, it also includes summaries for most procedures as a quick reference for experienced users.

If you will be digitally integrating the SMV 3000 transmitter with our TPS/TDC 3000® control system, we recommend that you use the *PM/APM Smartline Transmitter Integration Manual* supplied with the TDC 3000^X bookset as the main reference manual and supplement it with detailed transmitter information in Appendix A of this manual.

Note that this manual does not include detailed transmitter specifications. A detailed *Specification Sheet* is available separately or as part of the *Specifier’s Guide* which covers all Smartline transmitter models.

Conventions and Symbol Definitions

The following naming conventions and symbols are used throughout this manual to alert users of potential hazards and unusual operating conditions:



ATTENTION	ATTENTION indicates important information, actions or procedures that may indirectly affect operation or lead to an unexpected transmitter response.
CAUTION	CAUTION indicates actions or procedures which, if not performed correctly, may lead to faulty operation or damage to the transmitter.
WARNING	WARNING indicates actions or procedures which, if not performed correctly, may lead to personal injury or present a safety hazard.
	ElectroStatic Discharge (ESD) hazard. Observe precautions for handling electrostatic sensitive devices.
	Protective Earth terminal. Provided for connection of the protective earth (green or green/yellow) supply system conductor.

Table of Contents

References	xii
Technical Assistance	xii
SECTION 1 —OVERVIEW - FIRST TIME USERS ONLY	1
1.1 Introduction	1
1.2 CE Conformity (Europe)	3
1.3 SMV 3000 Smart Multivariable Transmitters	4
1.4 Smartline Configuration Toolkit (SCT 3000)	7
1.5 Smart Field Communicator (SFC)	8
1.6 Transmitter Order	11
SECTION 2—QUICK START REFERENCE	13
2.1 Introduction	13
2.2 Getting SMV 3000 Transmitter On-Line Quickly	14
SECTION 3—PREINSTALLATION CONSIDERATIONS.....	16
3.1 Introduction	16
3.2 Considerations for SMV 3000 Transmitter.....	17
3.3 Considerations for SCT 3000	21
SECTION 4—INSTALLATION.....	23
4.1 Introduction	23
4.2 Mounting SMV 3000 Transmitter	24
4.3 Piping SMV 3000 Transmitter	29
4.4 Installing RTD or Thermocouple	35
4.5 Wiring SMV 3000 Transmitter.....	36
SECTION 5—GETTING STARTED	45
5.1 Introduction	45
5.2 Establishing Communications.....	46
5.3 Making Initial Checks	50
5.4 Write Protect Option	51
SECTION 6—CONFIGURATION.....	45
6.1 Introduction	45
6.2 Overview	47
6.3 Configuring the SMV 3000 with The SCT	50
6.4 <i>Device</i> Configuration.....	51
6.5 <i>General</i> Configuration.....	52
6.6 <i>DPCConf</i> Configuration - PV1	56
6.7 <i>AP/GPCConf</i> Configuration - PV2.....	61
6.8 <i>TempConf</i> Configuration - PV3.....	64
6.9 <i>FlowConf</i> Configuration - PV4	71
6.10 Using Custom Engineering Units.....	77
6.11 Flow Compensation Wizard.....	78
6.12 Saving, Downloading and Printing a Configuration File.....	81
6.13 Verifying Flow Configuration	82

SECTION 7—STARTUP	79
7.1 Introduction	79
7.2 Startup Tasks.....	80
7.3 Running Output Check	81
7.4 Using Transmitter to Simulate PV Input.....	85
7.5 Starting Up Transmitter.....	89
SECTION 8—OPERATION	93
8.1 Introduction	93
8.2 Accessing Operation Data	94
8.3 Changing Default Failsafe Direction	98
8.4 Saving and Restoring a Database	102
SECTION 9—MAINTENANCE.....	103
9.1 Introduction	103
9.2 Preventive Maintenance	104
9.3 Inspecting and Cleaning Barrier Diaphragms	105
9.4 Replacing Electronics Module or PROM.....	108
9.5 Replacing Meter Body Center Section.....	113
SECTION 10—CALIBRATION	111
10.1 Introduction	111
10.2 Overview.....	112
10.3 Calibrating Analog Output Signal.....	114
10.4 Calibrating PV1 and PV2 Range Values.....	115
10.5 Resetting Calibration.....	117
SECTION 11—TROUBLESHOOTING.....	119
11.1 Introduction	119
11.2 Overview.....	120
11.3 Troubleshooting Using the SCT.....	121
11.4 Diagnostic Messages.....	122
SECTION 12—PARTS LIST	137
12.1 Replacement Parts	137
SECTION 13—REFERENCE DRAWINGS	147
13.1 Wiring Diagrams and Installation Drawings	147
APPENDIX A – PM/APM/HPM SMV 3000 INTEGRATION	149
A.1 Overview.....	149
A.2 Description.....	150
A.3 Data Exchange Functions.....	153
A.4 Installation.....	160
A.5 Configuration	162
A.6 Operation Notes.....	169
APPENDIX B—SMV 3000 CONFIGURATION RECORD SHEET	179
APPENDIX C—PV4 FLOW VARIABLE EQUATIONS	175
C.1 Overview.....	175
C.2 Standard Flow Equation	176
C.3 Dynamic Compensation Flow Equation	181

Figures and Tables

Figure 1	SMV 3000 Transmitter Handles Multiple Process Variable Measurements and Calculates Flow Rate	4
Figure 2	Functional Block Diagram for Transmitter in Analog Mode of Operation.....	5
Figure 3	Functional Block Diagram for Transmitter in Digital DE Mode of Operation.....	6
Figure 4	Smartline Configuration Toolkit.....	7
Figure 5	Typical SFC Communication Interface	8
Figure 6	Typical SMV 3000 Transmitter Order Components	11
Figure 7	Typical Mounting Area Considerations Prior to Installation.....	17
Figure 8	Typical Bracket Mounted Installations.....	24
Figure 9	Leveling a Transmitter with a Small Absolute Pressure Span.	28
Figure 10	Typical 3-Valve Manifold and Blow-Down Piping Arrangement.....	29
Figure 11	Transmitter Location Above Tap for Gas Flow Measurement	31
Figure 12	Transmitter Location Below the Tap for Liquid or Steam Flow Measurement.....	32
Figure 13	Operating Range for SMV 3000 Transmitters.....	36
Figure 14	SMV 3000 Transmitter Terminal Block	37
Figure 15	RTD Input Wiring Connections.	42
Figure 16	Thermocouple Input Wiring Connections.....	42
Figure 17	Ground Connection for Lightning Protection.....	43
Figure 18	SCT Hardware Components.....	46
Figure 19	Write Protect Jumper Location and Selections with Daughter PCB Removed.....	51
Figure 20	SMV On-line Configuration Process	47
Figure 21	Square Root Dropout Points for PV1	59
Figure 22	Typical Range Setting Values for PV3.....	68
Figure 23	Example of LRV and URV Interaction.....	69
Figure 24	Typical Volumetric Flow Range Setting Values	74
Figure 25	Graphic Representation of Sample Low Flow Cutoff Action.	76
Figure 26	Typical SCT or SFC and Meter Connections for SMV Start up Procedure.	92
Figure 27	Location of Failsafe Jumper on main PWA of Electronics Module.....	101
Figure 28	Typical PV1 or PV2 Range Calibration Hookup.....	116
Figure 29	Major SMV 3000 Smart Multivariable Transmitter Parts Reference.	138
Figure 30	SMV 3000 Electronics Housing.....	139
Figure 31	SMV 3000 Terminal Block Assembly	142
Figure 32	SMV 3000 Meter Body.....	143
Figure A-1	Typical PM/APM/HPM SMV 3000 Integration Hierarchy.	151
Figure A-2	Mapped Parameters are Basis for Data Exchange.....	153
Figure A-3	Sixteen AI Points per STIMV IOP	155
Figure A-4	AI Point for Each Transmitter Input.....	156
Figure A-5	Connection Rule Example.	161
Figure A-6	Detail Display with PV Number and Number of PVs Field.....	169
Figure A-7	Example of DECONF Download Error Message.	171

Figures and Tables, Continued

Table 1	Start-up Tasks Reference	14
Table 2	Operating Temperature Limits	19
Table 3	Transmitter Overpressure Ratings	19
Table 4	Thermocouple Types for Process Temperature Sensor	20
Table 5	Mounting SMV 3000 Transmitter to a Bracket	26
Table 6	Installing 1/2 inch NPT Flange Adapter	34
Table 7	Wiring the Transmitter	38
Table 8	Making SCT 3000 Hardware Connections	47
Table 9	Making SCT 3000 On-line Connections	48
Table 10	PV Type Selection for SMV Output	52
Table 11	SMV Analog Output Selection	54
Table 12	Pre-programmed Engineering Units for PV1	56
Table 13	Pre-programmed Engineering Units for PV2*	61
Table 14	Pre-programmed Engineering Units for PV3	64
Table 15	Sensor Types for PV3 Process Temperature Input	66
Table 16	Pre-programmed Volumetric Flow Engineering Units for PV4	71
Table 17	Pre-programmed Mass Flow Engineering Units for PV4	72
Table 18	Primary Flow Elements	78
Table 19	Analog Output Check Procedure	81
Table 20	Output Check for SMV Transmitters in DE Mode	84
Table 21	Using SMV Transmitter in the Input Mode	85
Table 22	Start up Procedure for SMV Transmitter Model SMA125	87
Table 23	Start up Procedure for SMV Transmitter Model SMG170	89
Table 24	Start up Procedure for SMV Transmitter Model SMA110	90
Table 25	Accessing Transmitter Operation Data Using SCT	94
Table 26	Cutting Failsafe Jumper	100
Table 27	Inspecting and Cleaning Barrier Diaphragms	105
Table 28	Replacing Electronics Module or PROM	108
Table 29	Replacing Meter Body Center Section	113
Table 30	Accessing SMV 3000 Diagnostic Information using the SCT	121
Table 31	Critical Status Diagnostic Message Table	123
Table 32	Non-Critical Status Diagnostic Message Table	126
Table 33	Communication Status Message Table	132
Table 34	Informational Status Message Table	134
Table 35	SFC Diagnostic Message Table	135
Table 36	Parts Identification for Callouts in Figure 30	140
Table 37	Parts Identification for Callouts in Figure 31	142
Table 38	Parts Identification for Callouts in Figure 32	143
Table 39	Summary of Recommended Spare Parts	146
Table A-1	Summary of SMV 3000 Transmitter PVs Configuration	158
Table A-2	Typical SMV 3000 Database Size and Broadcast Time	159
Table A-3	Base Engineering Units for SMV 3000 Transmitter PVs	164
Table A-4	Sensor Type Selections for SMV 3000 PVs	165
Table A-5	PV Characterization Selections for SMV 3000 PVs	165
Table A-6	DECONF and PV Type Parameter Entry Comparison	166
Table A-7	Example URLs for a SMV Transmitter Model SMA125	166
Table A-8	Damping Range Values for SMV 3000 Transmitter PVs	168

Figures and Tables, Continued

Table A-9	Conversion Values for PV1 and PV2 Pressures	172
Table A-10	Conversion Values for PV3 Temperature	172
Table A-11	Conversion Values for PV4 as Volumetric Flow Rate	174
Table A-12	Conversion Values for PV4 as Mass Flow Rate	176
Table A-13	Additional IOP Status Messages.....	177
Table C-1	Air Through a Venturi Meter Configuration Example	177
Table C-2	Superheated Steam using an Averaging Pitot Tube Configuration Example	179
Table C-3	Liquid Propane Configuration Example	182
Table C-4	Air Configuration Example	185
Table C-5	Superheated Steam Configuration Example.....	189

Acronyms

A.G.A.	American Gas Association
AP	Absolute Pressure
APM	Advanced Process Manager
AWG	American Wire Gauge
CJ	Cold Junction
CJT	Cold Junction Temperature
DE	Digital Enhanced Communications Mode
DP	Differential Pressure
ECJT	External Cold Junction Temperature
EMI	Electromagnetic Interference
FTA	Field Termination Assembly
GP	Gauge Pressure
HP	High Pressure
HP	High Pressure Side (DP Transmitter)
Hz	Hertz
inH ₂ O	Inches of Water
KCM	Kilo Circular Mills
LCN	Local Control Network
LGP	In-Line Gauge Pressure
LP	Low Pressure
LP	Low Pressure Side (DP Transmitter)
LRL	Lower Range Limit
LRV	Lower Range Value
mAdc	Milliamperes Direct Current
mmHg	Millimeters of Mercury
mV	Millivolts
n·m	Newton·Meters
NPT	National Pipe Thread
NVM	Non-Volatile Memory
PM	Process Manger
PROM	Programmable Read Only Memory
PSI	Pounds per Square Inch
PSIA	Pounds per Square Inch Absolute
PV	Process Variable
PWA	Printed Wiring Assembly
RFI	Radio Frequency Interference
RTD	Resistance Temperature Detector
SFC	Smart Field Communicator
STIM	Smart Transmitter Interface Module
STIMV IOP	Smart Transmitter Interface Multivariable Input/Output Processor
T/C	Thermocouple
URL	Upper Range Limit
URV	Upper Range Value
US	Universal Station
Vac	Volts Alternating Current
Vdc	Volts Direct Current
XMTR	Transmitter

Parameters

A'_d	Area of orifice
A'_u	Area of pipe
C	Flow coefficient or orifice discharge coefficient
d_1	Inside diameter of pipe
d_2	Orifice plate bore diameter at flowing temperature
d_o	Inside diameter of orifice
E_v	Velocity of approach factor
F_{pv}	Super compressibility factor
g	Acceleration of gravity
K_q	Scaling factor for volumetric flow in PV4 algorithm
K_w	Scaling factor for mass flow in PV4 algorithm
N_c	Units conversion factor
P	Pressure
P_a	Measured static pressure in PV4 algorithm
P_c	Absolute critical pressure of the gas
P_d	Static pressure at downstream point
P_{dp}	Measured differential pressure in Pascals in PV4 algorithm
P_f	Absolute pressure of flowing gas
P_r	Reduced pressure
P_u	Static pressure at upstream point
Q_h	Volumetric rate of flow in PV4 algorithm
Q_s	Rate of flow
R	Gas constant
T	Absolute temperature
T_a	Measure process temperature in PV4 algorithm
T_c	Absolute critical temperature of the gas
T_f	Absolute temperature of flowing gas
T_r	Reduced temperature
T_{ref}	Absolute temperature of reference flow in PV4 algorithm
v	Specific volume
V_d	Fluid velocity at downstream point
V_u	Fluid velocity at upstream point
W_h	Mass rate of flow in PV4 algorithm
Y	Expansion factor
Z	Compressibility factor
γ (gamma)	Fluid density
ρ	Density
ρ_{act}	Actual density in PV4 algorithm
ρ_{des}	Design density in PV4 algorithm
ρ_r	Density of fluid under reference conditions

References

Publication Title	Publication Number	Binder Title	Binder Number
<i>SCT 3000 Smartline Configuration Toolkit Start-up and Installation Manual</i>	34-ST-10-08		
<i>ST 3000 Smart Field Communicator Model STS103 Operating Guide</i>	34-ST-11-14		
For R400 and later:			
<i>PM/APM Smartline Transmitter Integration Manual</i>	PM12-410	Implementation/ PM/APM Optional Devices	TDC 2045

Technical Assistance

If you encounter a problem with your SMV 3000 Smart Multivariable Transmitter, check to see how your transmitter is currently configured to verify that all selections are consistent with your application.

If the problem persists, you can call our Solutions Support Center between the hours of 8:00 am and 4:00 pm EST Monday through Friday for direct factory technical assistance.

1-800-423-9883 (U. S. only)

OR

1-215-641-3410

FAX: 1-215-641-3400

An engineer will discuss your problem with you. Please have your complete model number, serial number, and software revision number on hand for reference. You can find the model and serial numbers on the transmitter nameplates. You can also view the software version number using the SCT or SFC.

If it is determined that a hardware problem exists, a replacement transmitter or part will be shipped with instructions for returning the defective unit. Please do not return your transmitter without authorization from Honeywell's Solutions Support Center or until the replacement has been received.

Section 1 —Overview - First Time Users Only

1.1 Introduction

Section Contents

This section includes these topics.

Topic	See Page
1.1 Introduction	1
1.2 CE Conformity (Europe)	3
1.3 SMV 3000 Smart Multivariable Transmitters	4
1.4 Smartline Configuration Toolkit (SCT 3000)	7
1.5 Smart Field Communicator (SFC)	8
1.6 Transmitter Order.....	11

About This Section

This section is intended for users who have never worked with our SMV 3000 Smart Multivariable Transmitter and the SCT 3000 Smartline Configuration Toolkit before. It provides some general information to acquaint you with the SMV 3000 transmitter and the SCT 3000.

ATTENTION

To be sure that you have the SCT software version that is compatible with your SMV 3000, please note the following table.

If your SMV 3000 contains software version . . .	Then use this compatible SCT software version . . .	* Compatible TDC STIMV IOP module
1.1 through 1.5	3.06.00	5.3
2.1	3.11.2	
2.5 or 3.1	3.12.3	
2.5, 3.1 or 4.0	4.02.013a	

STIMV IOP Module Revision Level

* If the SMV 3000 will be integrated with our TPS/TDC control systems, you must have an STIMV IOP module in your Process Manager, Advanced Process Manager, or High Performance Process Manager. The STIMV IOP module must be at least revision level 5.3 or greater to be compatible with the SMV 3000. Contact your Honeywell representative for information on upgrading an STIMV IOP.

1.2 CE Conformity (Europe)

About Conformity

This product is in conformity with the protection requirements of **89/336/EEC**, the EMC Directive. Conformity of this product with any other “CE Mark” Directive(s) shall not be assumed.

Deviation from the installation conditions specified in this manual may invalidate this product’s conformity with the EMC Directive.

ATTENTION

ATTENTION

The emission limits of EN 50081-2 are designed to provide reasonable protection against harmful interference when this equipment is operated in an industrial environment. Operation of this equipment in a residential area may cause harmful interference. This equipment generates, uses, and can radiate radio frequency energy and may cause interference to radio and television reception when the equipment is used closer than 30 meters (98 feet) to the antenna(e). In special cases, when highly susceptible apparatus is used in close proximity, the user may have to employ additional mitigating measures to further reduce the electromagnetic emissions of this equipment.

1.3 SMV 3000 Smart Multivariable Transmitters

About the Transmitter The SMV 3000 Smart Multivariable Transmitter shown in Figure 1 measures three separate process variables and calculates volumetric or mass flow rate for gases, steam or liquids for output over a 4 to 20 milliampere, two-wire loop. Its general design is based on the field proven technology of our ST 3000 Smart Pressure Transmitter and meets the same high performance standards.

Figure 1 SMV 3000 Transmitter Handles Multiple Process Variable Measurements and Calculates Flow Rate

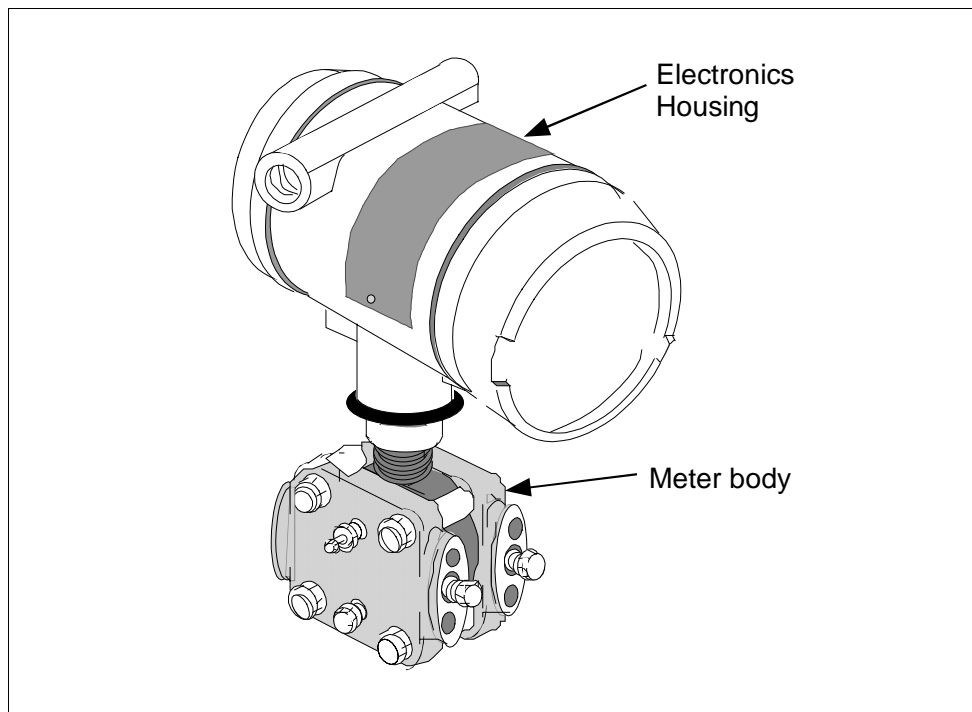

The SMV 3000 transmitter accepts process temperature signals from an external Resistance Temperature Detector (RTD) or any one of several common thermocouple types. Its unique measurement sensor simultaneously handles differential pressure, static pressure, and meter body temperature signals while a separate circuit processes the process temperature input. Note that the static pressure (absolute or gauge) is read from the high pressure side of the meter body.

Using stored equations in conjunction with the multiple process variable inputs, the SMV 3000 calculates a compensated volumetric or mass flow rate output for gases, liquids and steam. Its output signal is proportional to the calculated differential flow rate.

Continued on next page

1.3 SMV 3000 Smart Multivariable Transmitters, Continued

SMV Operating Modes The SMV 3000 can transmit its output in either an analog 4 to 20 milliampere format or a Digitally Enhanced (DE) protocol format for direct digital communications with our TPS/TDC 3000 control system. In the analog format, only a selected variable is available as an output which can be any one of the following:

- Differential Pressure PV1,
- Static Pressure PV2,
- Process Temperature PV3, or
- Calculated Flow Rate PV4

Note that the secondary variable is only available as a read only parameter through the SCT or SFC. See Figure 2.

Figure 2 Functional Block Diagram for Transmitter in Analog Mode of Operation.

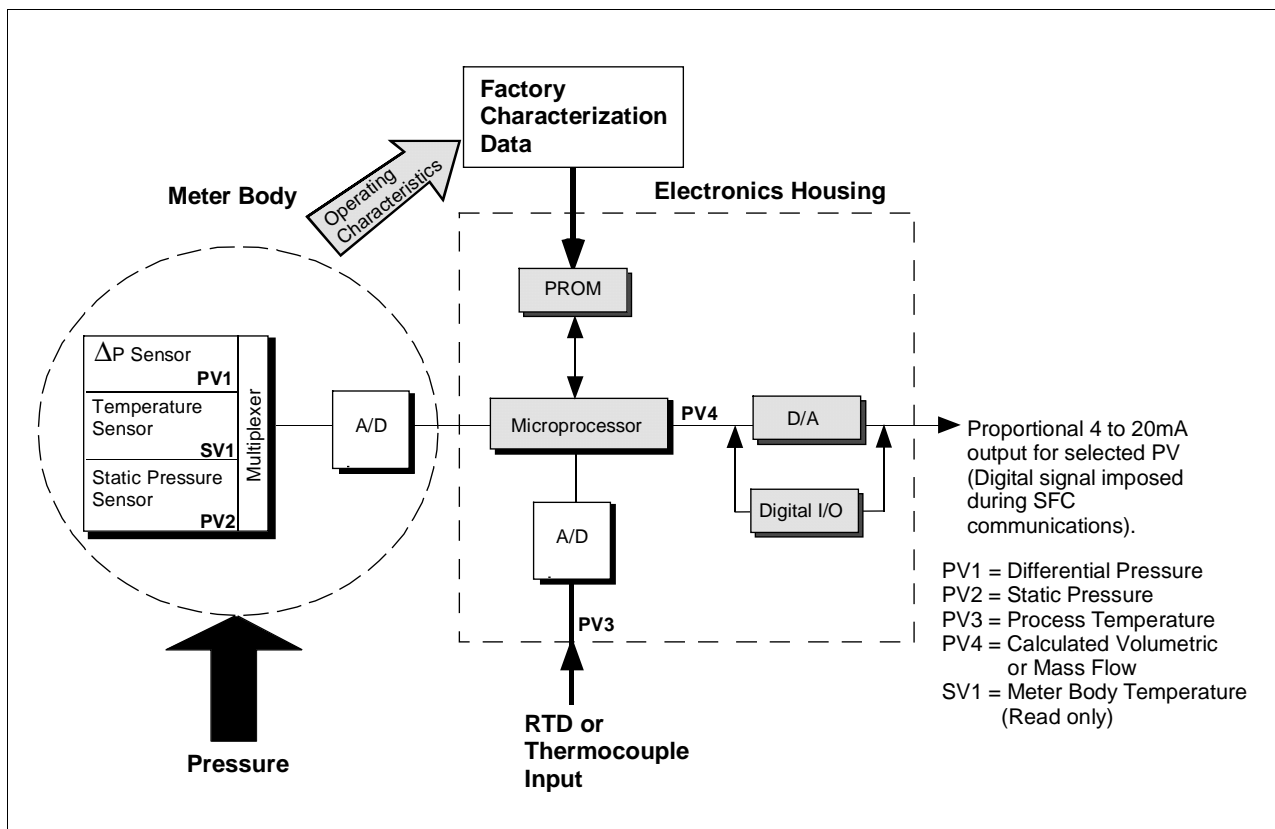

Continued on next page

1.3 SMV 3000 Smart Multivariable Transmitters, Continued

SMV Operating Modes, continued

In the digital DE protocol format, all four process variables are available for monitoring and control purposes; and the meter body temperature is also available as a secondary variable for monitoring purposes only - See Figure 3.

Figure 3 Functional Block Diagram for Transmitter in Digital DE Mode of Operation.

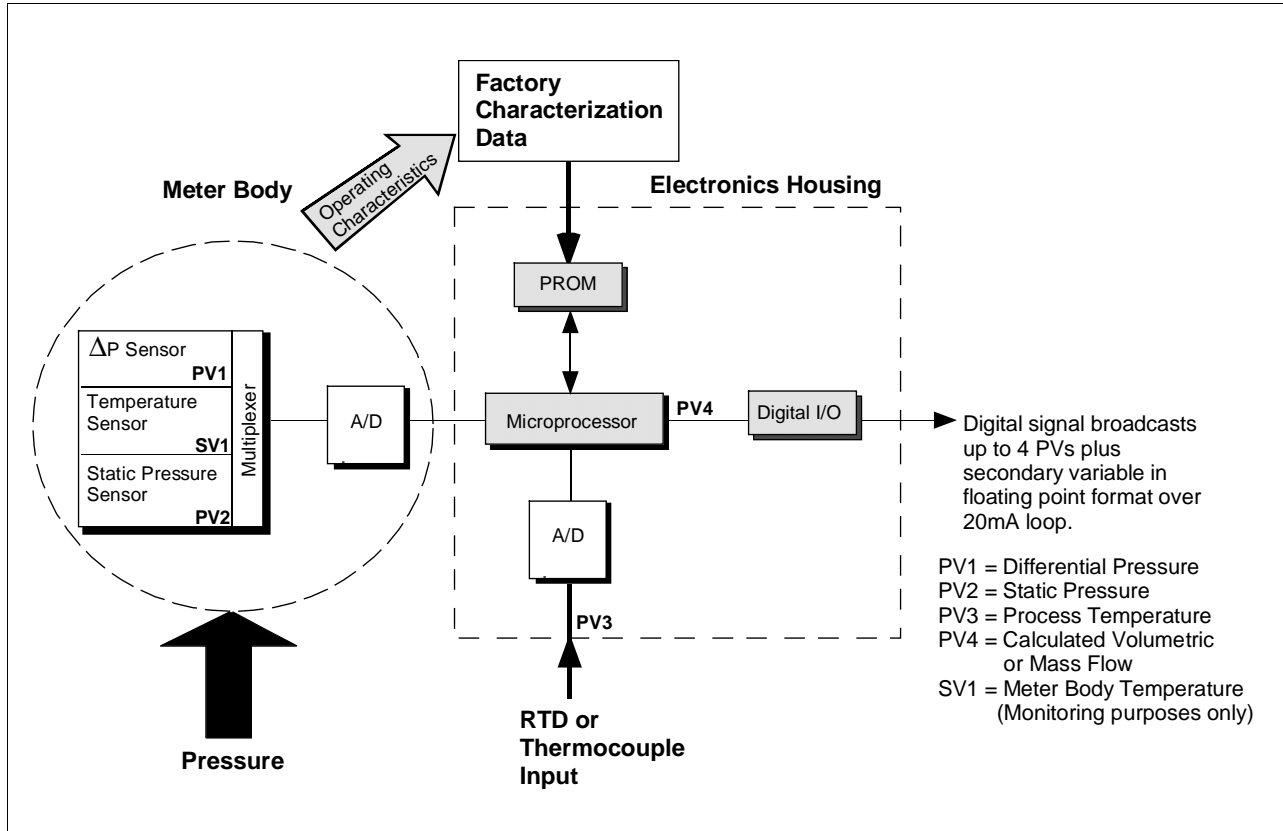

Transmitter adjustments

The SMV 3000 transmitter has no physical adjustments. You need an SCT to make any adjustments in an SMV 3000 transmitter. Alternately, certain adjustments can be made through the Universal Station if the transmitter is digitally integrated with our TPS/TDC 3000 control system.

1.4 Smartline Configuration Toolkit (SCT 3000)

Smartline Configuration Toolkit

Honeywell's SCT 3000 Smartline Configuration Toolkit is a cost-effective means to configure, calibrate, diagnose, and monitor the SMV 3000 and other smart field devices. The SCT 3000 runs on a variety of Personal Computer (PC) platforms using Windows 95[®], Windows 98[®], and Windows NT[®]. It is a bundled Microsoft Windows software and PC-interface hardware solution that allows quick, error-free configuration of SMV transmitters. Figure 4 shows the major components of the SCT 3000.

Some SCT 3000 features include:

- Preconfigured templates that simplify configuration and allow rapid development of configuration databases.
- Context-sensitive help and a comprehensive on-line user manual.
- Extensive menus and prompts that minimize the need for prior training or experience.
- The ability to load previously configured databases at time of installation.
- Automatic verification of device identification and database configuration menus and prompts for bench set up and calibration.
- The ability to save unlimited transmitter databases on the PC.

Please refer to the table on Page 1 for SCT software versions that are compatible with your SMV 3000 transmitter. Contact your Honeywell representative for more information.

Figure 4 Smartline Configuration Toolkit

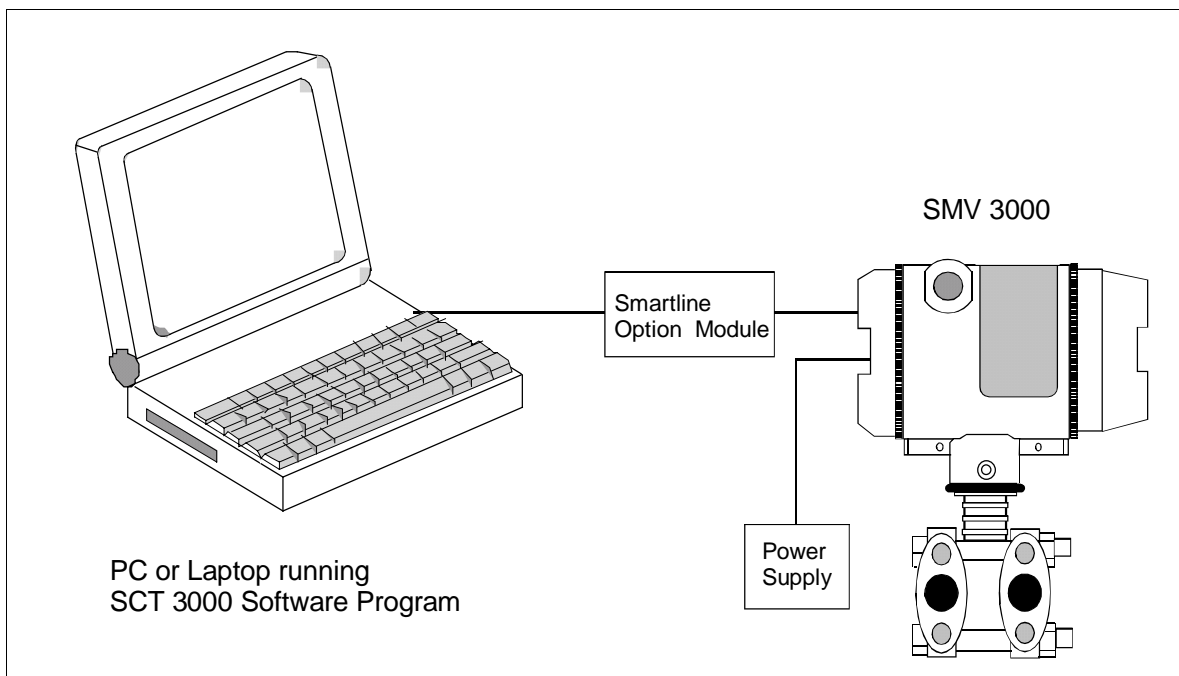

1.5 Smart Field Communicator (SFC)

About SFC Communications

The portable, battery-powered SFC serves as the common communication interface device for Honeywell's family of Smartline Transmitters. It communicates with a transmitter through serial digital signals over the 4 to 20 milliampere line used to power the transmitter. A request/response format is the basis for the communication operation. The transmitter's microprocessor receives a communication signal from the SFC, identifies the request, and sends a response message.

Figure 5 shows a simplified view of the communication interface provided by an SFC.

Figure 5 Typical SFC Communication Interface

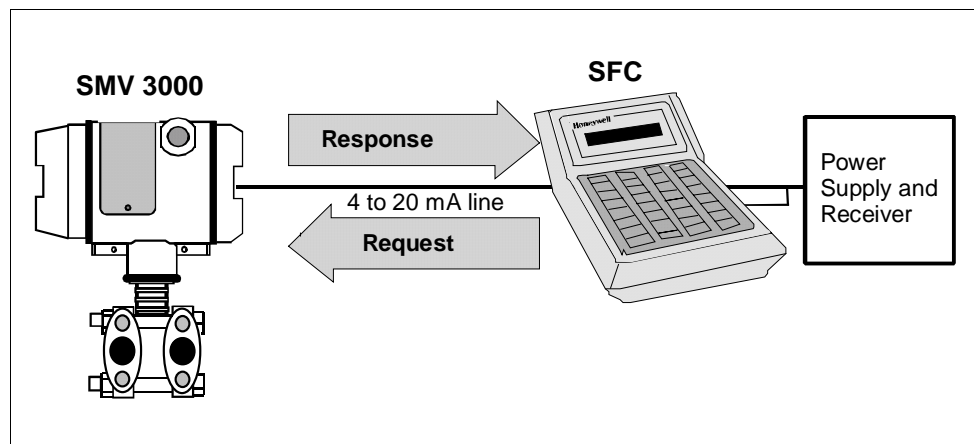

ATTENTION

Because of the advanced capabilities built-in to the SMV 3000, we **do not** recommend that you use the SFC to configure the SMV transmitter. Some of the SMV's advanced functions are not supported by the SFC. Although you can use the SFC to perform certain operations, such as calibrate or re-range the transmitter, read transmitter status and diagnose faults.

Using the SFC with the SMV 3000

If you use the SFC to communicate with the SMV, you can adjust transmitter values, or diagnose potential problems from a remote location such as the control room. You can use the SFC to:

- Monitor: Read the input pressure, process temperature, or secondary variable to the transmitter in engineering units.
- Display: Retrieve and display data from the transmitter or SFC memory.

Continued on next page

1.5 Smart Field Communicator (SFC), Continued

Using the SFC with the SMV 3000,
continued

- **Change Mode of Operation:** Tell transmitter to operate in either its analog (4-20 mA) mode or its digital enhanced (DE) mode.
 - **Check Current Output:** Use the transmitter to supply the output current desired for verifying analog loop operation, troubleshooting, or calibrating other components in the analog loop.
 - **Simulate Input:** Use the transmitter to simulate a desired input value for the selected PV for verifying transmitter operation.
 - **Troubleshoot:** Check status of transmitter operation and display diagnostic messages to identify transmitter, communication, or operator error problems.
-

ATTENTION

For more information about using the SFC with the SMV 3000, see the *Smart Field Communicator Model STS103 Operating Guide, 34-ST-11-14*. The document provides complete keystroke actions and prompt displays.

Continued on next page

1.6 Transmitter Order

Order Components Figure 6 shows the components that would be shipped and received for a typical SMV 3000 transmitter order.

Figure 6 Typical SMV 3000 Transmitter Order Components

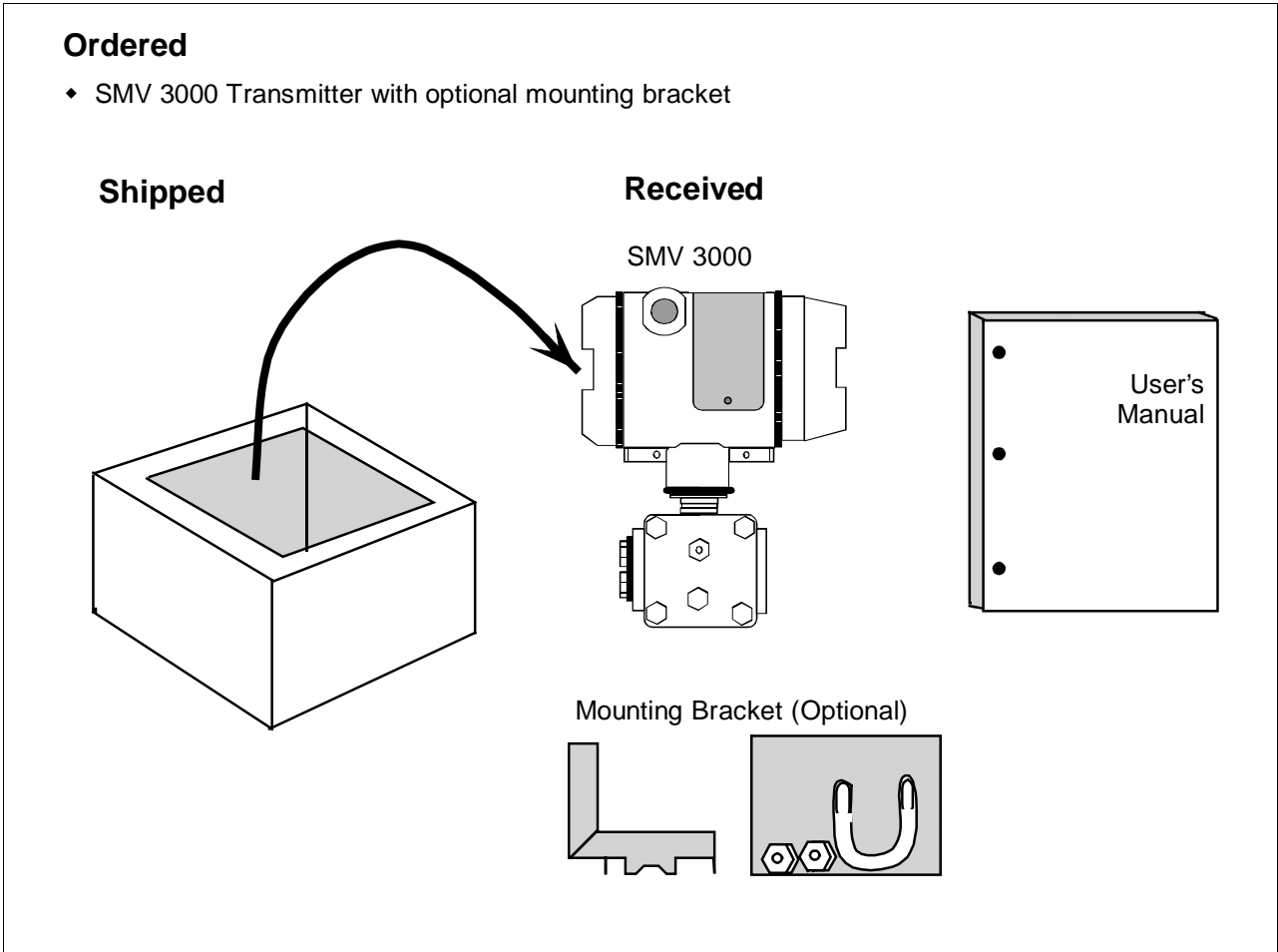

ATTENTION

Honeywell can also supply the RTD or Thermocouple for use with an SMV 3000. See “About Documentation,” next.

Continued on next page

1.6 Transmitter Order, Continued

- About Documentation**
- *SCT 3000 Smartline Configuration Toolkit Start-up and Installation Manual 34-ST-10-08*: One copy supplied with the SCT 3000 Smartline Configuration Toolkit. This document provides basic information on installation, setup and operation of the SCT 3000. It is a companion document to the SCT on-line user manual.
 - *SMV 3000 Smart Multivariable Transmitter User's Manual 34-SM-25-02*: One copy is shipped with every transmitter order up to five units. Orders for more than five units will ship with one SMV user manual for every five transmitters. This document provides detailed information for installing, wiring, configuring, starting up, operating, maintaining, and servicing the SMV 3000 transmitter. This is the main reference manual for the SMV 3000 transmitter.
 - *Smart Field Communicator Model STS103 Operating Guide 34-ST-11-14*: One copy is shipped with every SFC. This document provides generic SFC information and detailed keystroke actions for interfacing with these Honeywell Smartline Transmitters.
 - SMV 3000 Smart Multivariable Transmitter
 - ST 3000 Smart Pressure Transmitter
 - STT 3000 Smart Temperature Transmitter
 - MagneW 3000 Smart Electromagnetic Flowmeter
 - *Guide to Temperature Sensors and Thermowells, 34-44-29-01*: This document tells you how to properly specify thermal probes and thermowell assemblies for your application. Model selection guides also are included for various temperature probes.
-

Section 2 —Quick Start Reference

2.1 Introduction

Section Contents

This section includes these topics

Topic	See Page
2.1 Introduction	13
2.2 Getting SMV 3000 Transmitter On-Line Quickly.....	14

About this section

This section provides a list of typical start-up tasks and tells you where you can find detailed information about performing the task.

This section assumes that the SMV 3000 transmitter has been installed and wired correctly, and is ready to be put into operation. It also assumes that you are somewhat familiar with using the SCT and that the transmitter has been configured correctly for your application. If the transmitter has not been installed and wired, you are not familiar with SCT operation, and/or you do not know if the transmitter is configured correctly, please read the other sections of this manual or refer to the *SCT 3000 Smartline Configuration Toolkit Start-up and Installation Manual (34-ST-10-08)* before starting up your transmitter.

2.2 Getting SMV 3000 Transmitter On-Line Quickly

Quick Start-up Tasks Table 1 lists common start-up tasks for an SMV 3000 transmitter using the SCT and gives an appropriate section in this manual to reference for more information about how to do the task. The start-up tasks are listed in the order they are commonly completed.

Table 1 Start-up Tasks Reference

Task	Description	Reference Section
1	Put analog loop into manual mode.	Appropriate vendor documentation for controller or recorder used as a receiver in analog loop with SMV 3000 transmitter.
2	Connect SCT to transmitter and establish communications	5.2
3	Identify transmitter's mode of operation.	5.3
4	Change mode of operation, if required.	5.3
5	Check/set output conformity (Linear/Square Root) for PV1.	6.6
6	Check/set damping times for all PVs.	6.6 (for PV1) 6.7 (for PV2) 6.8 (for PV3) 6.9 (for PV4)
7	Check/set Probe Configuration for PV3	6.8
8	Check/set PV4 Algorithm	6.9, 6.10, 6.11
9	Check/set Lower Range Values and Upper Range Values for all PVs.	6.6 (for PV1) 6.7 (for PV2) 6.8 (for PV3) 6.9 (for PV4)
10	Select PV to represent output for transmitter in analog mode only.	6.5
11	Run optional output check for analog loop.	7.3
12	Perform start-up procedures - Check zero input and set, if required.	7.5
13	Check transmitter status, access operating data.	8.2

Section 3 —Preinstallation Considerations

3.1 Introduction

Section Contents

This section includes these topics

Topic	See Page
3.1 Introduction	16
3.2 Considerations for SMV 3000 Transmitter.....	17
3.3 Considerations for SCT 3000	21

About this section

This section reviews things you should take into consideration before you install the transmitter and start using the SCT. Of course, if you are replacing an existing SMV 3000 transmitter, you can skip this section.

3.2 Considerations for SMV 3000 Transmitter

Evaluate conditions

The SMV 3000 transmitter is designed to operate in common indoor industrial environments as well as outdoors. To assure optimum performance, evaluate these conditions at the mounting area relative to published transmitter specifications and accepted installation practices for electronic pressure transmitters.

- Environmental Conditions
 - Ambient Temperature
 - Relative Humidity
- Potential Noise Sources
 - Radio Frequency Interference (RFI)
 - Electromagnetic Interference (EMI)
- Vibration Sources
 - Pumps
 - Motorized Valves
 - Valve Cavitation
- Process Characteristics
 - Temperature
 - Maximum Pressure Rating

Figure 7 illustrates typical mounting area considerations to make before installing a transmitter.

Figure 7 Typical Mounting Area Considerations Prior to Installation

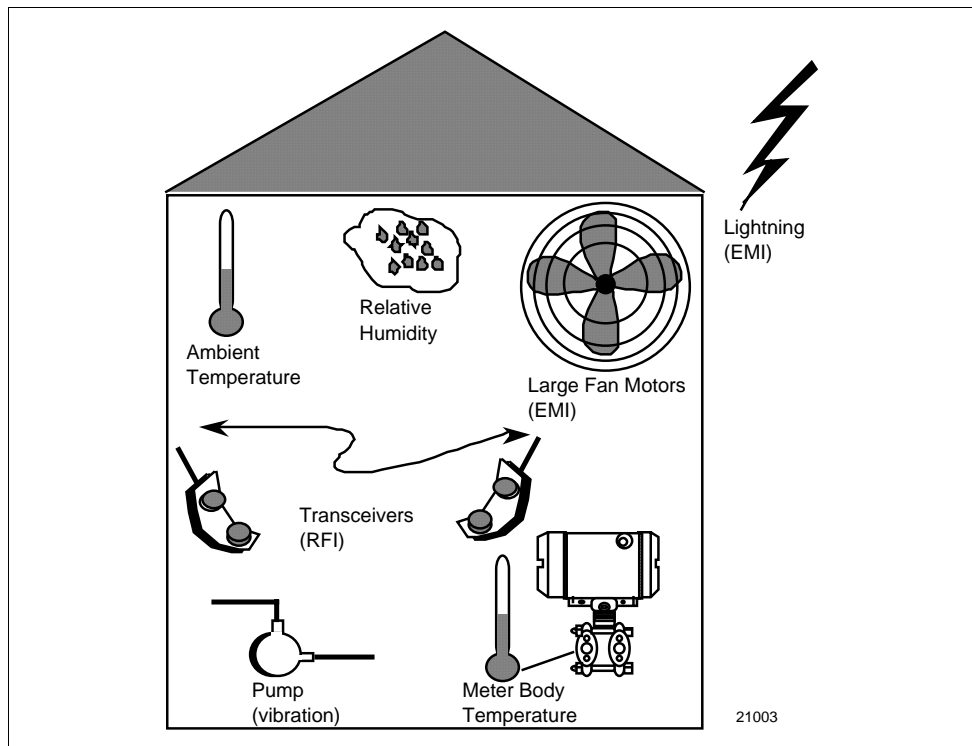

Continued on next page

3.2 Considerations for SMV 3000 Transmitter, Continued

Temperature limits Table 2 lists the operating temperature limits for reference.

Table 2 Operating Temperature Limits

Transmitter Type		Ambient Temperature	Meter Body
Multivariable	°C	–40 to 93	–40 to 125 *
	°F	–40 to 200	–40 to 257 *

* For CTFE fill fluid, the rating is –15 to 110 °C (5 to 230 °F)

Overpressure ratings Table 3 lists overpressure rating for a given Upper Range Limit (URL) for reference.

Table 3 Transmitter Overpressure Ratings

SMV 3000 Transmitter Model	Upper Range Limit (URL)	Overpressure Rating
SMA110	25 inches H ₂ O @ 39.2 °F (differential pressure)	100 psi
	100 psia (absolute pressure) *	100 psi
SMA125	400 inches H ₂ O @ 39.2 °F (differential pressure)	3000 psi
	750 psia (absolute pressure) *	3000 psi
SMG170	400 inches H ₂ O @ 39.2 °F (differential pressure)	3000 psi
	3000 psig (gauge pressure)	3000 psi

* Static pressure is referenced at high pressure port.

3.2 Considerations for SMV 3000 Transmitter, Continued

RTD requirements

Use a two-, three-, or four-wire platinum 100 ohm (Pt100) Resistance Temperature Detector with rated measurement range limits of -200 to 450 °C (-328 to 842 °F) per DIN 43760 standard ($\alpha = 0.00385$ $\Omega/\Omega/^\circ\text{C}$) as the input source for the process temperature PV.

Thermocouple requirements

Use one of the thermocouple types listed in Table 4 as the input source for the process temperature.

Table 4 Thermocouple Types for Process Temperature Sensor

Type	Rated Range Limits		Standard
	°C	°F	
E	0 to 1000	32 to 1832	IEC584.1
J	0 to 1200	32 to 2192	IEC584.1
K	-100 to 1250	-148 to 2282	IEC584.1
T	-100 to 400	-148 to 752	IEC584.1

3.3 Considerations for SCT 3000

SCT 3000 Requirements

The SCT 3000 consists of the software program which is contained on diskettes and a Smartline Option Module which is the hardware interface used for connecting the host computer to the SMV transmitter.

Be certain that the host computer is loaded with the proper operating system necessary to run the SCT program. See the *SCT 3000 Smartline Configuration Toolkit Start-up and Installation Manual 34-ST-10-08* for complete details on the host computer specifications and requirements for using the SCT 3000.

Section 4 —Installation

4.1 Introduction

Section Contents

This section includes these topics

Topic	See Page
4.1 Introduction	19
4.2 Mounting SMV 3000 Transmitter.....	20
4.3 Piping SMV 3000 Transmitter.....	29
4.4 Installing RTD or Thermocouple.....	35
4.5 Wiring SMV 3000 Transmitter	36

About this section

This section provides information about installing the SMV 3000 transmitter. It includes procedures for mounting, piping and wiring the transmitter for operation.

4.2 Mounting SMV 3000 Transmitter

Summary

You can mount the transmitter to a 2-inch (50 millimeter) vertical or horizontal pipe using our optional angle or flat mounting bracket or a bracket of your own.

Figure 8 shows typical bracket mounted installations for comparison.

Figure 8 Typical Bracket Mounted Installations

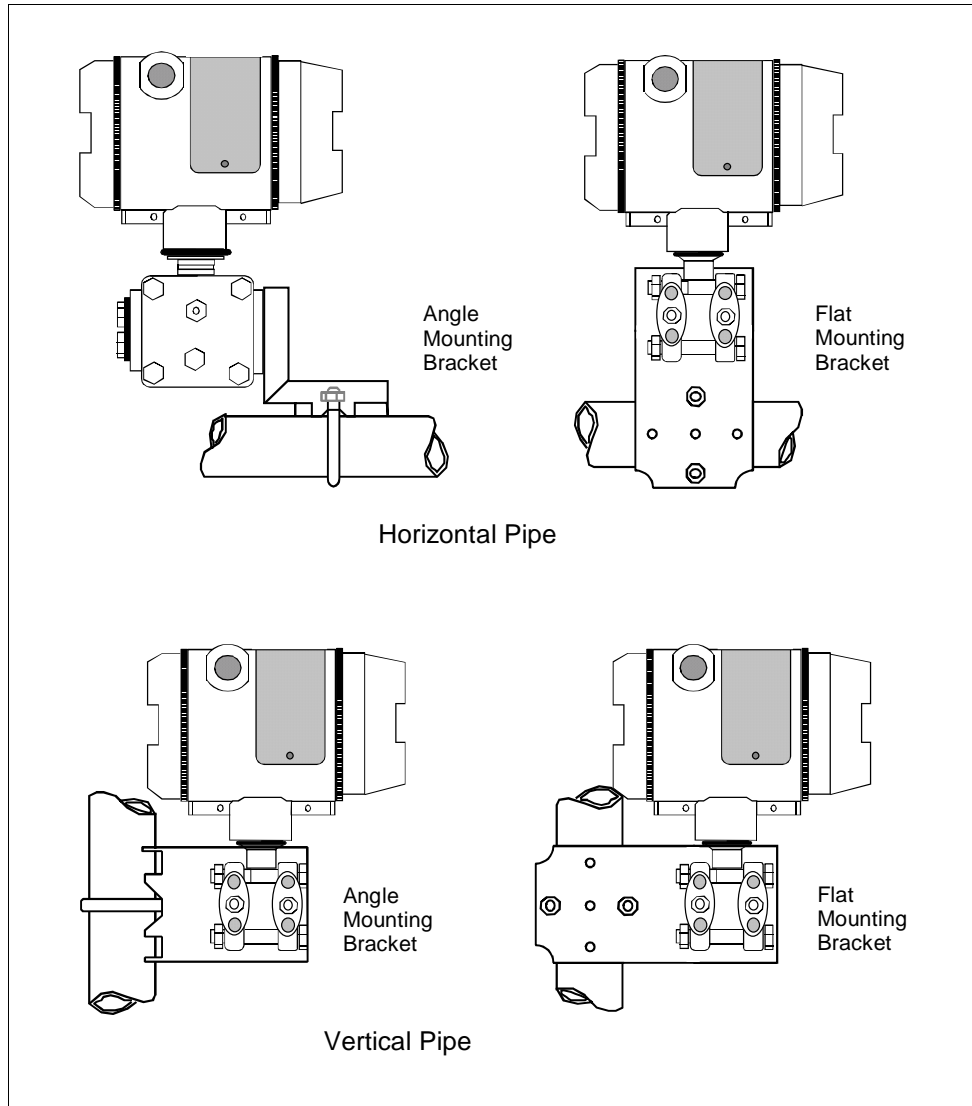

Dimensions

Detailed dimension drawings for given mounting bracket type are listed in the back of this manual for reference. This section assumes that the mounting dimensions have already been taken into account and the mounting area can accommodate the transmitter.

Continued on next page

4.2 Mounting SMV 3000 Transmitter, Continued

Bracket mounting Table 5 summarizes typical steps for mounting a transmitter to a bracket.

Table 5 Mounting SMV 3000 Transmitter to a Bracket

Step	Action						
1	<table border="1" data-bbox="686 531 1414 646"> <thead> <tr> <th data-bbox="686 531 1047 569">If you are using an...</th> <th data-bbox="1047 531 1414 569">Then...</th> </tr> </thead> <tbody> <tr> <td data-bbox="686 569 1047 606">optional mounting bracket</td> <td data-bbox="1047 569 1414 606">go to Step 2.</td> </tr> <tr> <td data-bbox="686 606 1047 646">existing mounting bracket</td> <td data-bbox="1047 606 1414 646">go to Step 3.</td> </tr> </tbody> </table>	If you are using an...	Then...	optional mounting bracket	go to Step 2.	existing mounting bracket	go to Step 3.
If you are using an...	Then...						
optional mounting bracket	go to Step 2.						
existing mounting bracket	go to Step 3.						
2	<p data-bbox="643 701 1446 793">Position bracket on 2-inch (50.8 mm) horizontal or vertical pipe, and install “U” bolt around pipe and through holes in bracket. Secure with nuts and lockwashers provided.</p> <p data-bbox="643 821 1422 877">Example - Angle mounting bracket secured to horizontal or vertical pipe.</p> <div data-bbox="643 919 1446 1346"> </div>						

Continued on next page

4.2 Mounting SMV 3000 Transmitter, Continued

Bracket mounting, continued

Table 5 Mounting SMV 3000 Transmitter to a Bracket, continued

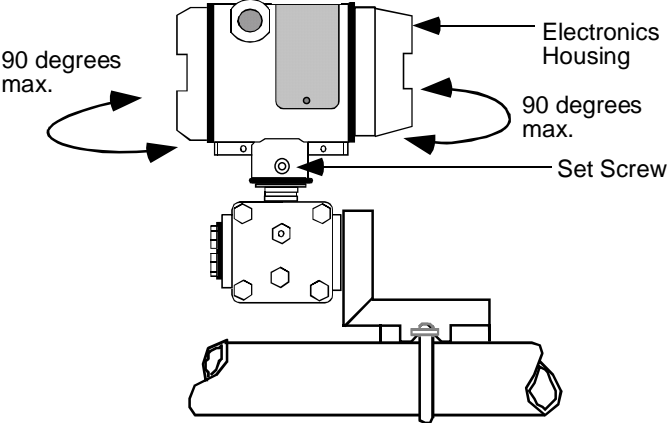
Step	Action
3	Align alternate mounting holes in end of meter body heads with holes in bracket and secure with bolts and washers provided.
4	<p>Loosen the 4 mm set screw on outside neck of transmitter. Rotate electronics housing in maximum of 90 degree increments in left or right direction from center to position you require and tighten set screw.</p> <p>Example - Rotating electronics housing.</p> 

Continued on next page

4.2 Mounting SMV 3000 Transmitter, Continued

ATTENTION

The mounting position of an SMV 3000 Transmitter is critical as the transmitter spans become smaller for the absolute and/or differential pressure range. A maximum zero shift of 0.048 psi for an absolute pressure range or 1.5 in H₂O for a differential pressure range can result from a mounting position which is rotated 90 degrees from vertical. A typical zero shift of 0.002 psi or 0.20 in H₂O can occur for a 5 degree rotation from vertical.

Precautions for Mounting Transmitters with Small Differential Pressure Spans

To minimize these positional effects on calibration (zero shift), take the appropriate mounting precautions that follow for the given pressure range.

- For a transmitter with a small differential pressure span, you must ensure that the transmitter is vertical when mounting it. You do this by leveling the transmitter side-to-side and front-to-back. See Figure 9 for suggestions on how to level the transmitter using a spirit balance.
- You must also zero the transmitter by adjusting the mounting position of the transmitter. Refer to start-up procedure in Section 7 for SMV 3000 transmitter model SMA110 and transmitters with small differential pressure spans.

Figure 9 Leveling a Transmitter with a Small Absolute Pressure Span.

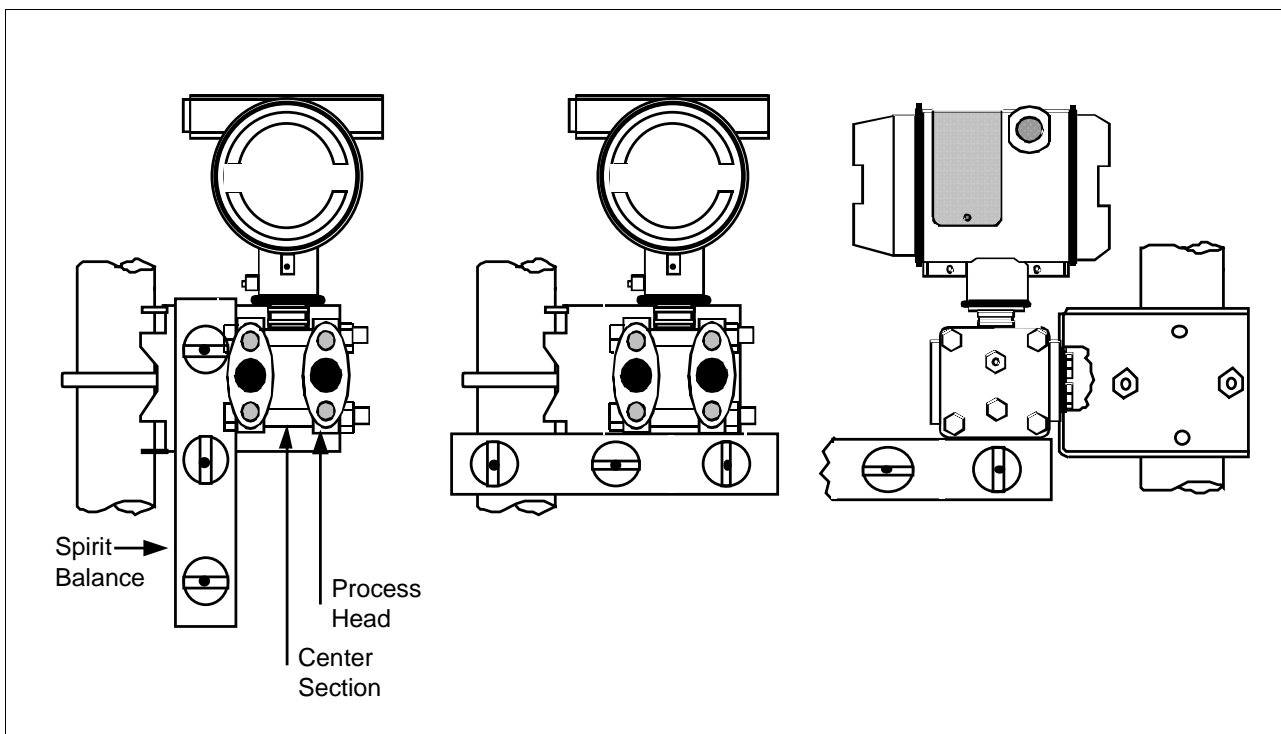

4.3 Piping SMV 3000 Transmitter

Summary

The actual piping arrangement will vary depending upon the process measurement requirements. Process connections can be made to standard 1/4-inch NPT female connections on 2-1/8 inch centers in the double-ended process heads of the transmitter's meter body. Or, the connections in the process heads can be modified to accept 1/2 inch NPT adapter flange for manifolds on 2, 2-1/8, or 2-1/4 inch centers

The most common type of pipe used is 1/2 inch schedule 40 steel pipe. Many piping arrangements use a three-valve manifold to connect the process piping to the transmitter. A manifold makes it easy to install and remove a transmitter without interrupting the process. It also accommodates the installation of blow-down valves to clear debris from pressure lines to the transmitter.

Figure 10 shows a diagram of a typical piping arrangement using a three-valve manifold and blow-down lines for a flow measurement application.

Figure 10 Typical 3-Valve Manifold and Blow-Down Piping Arrangement.

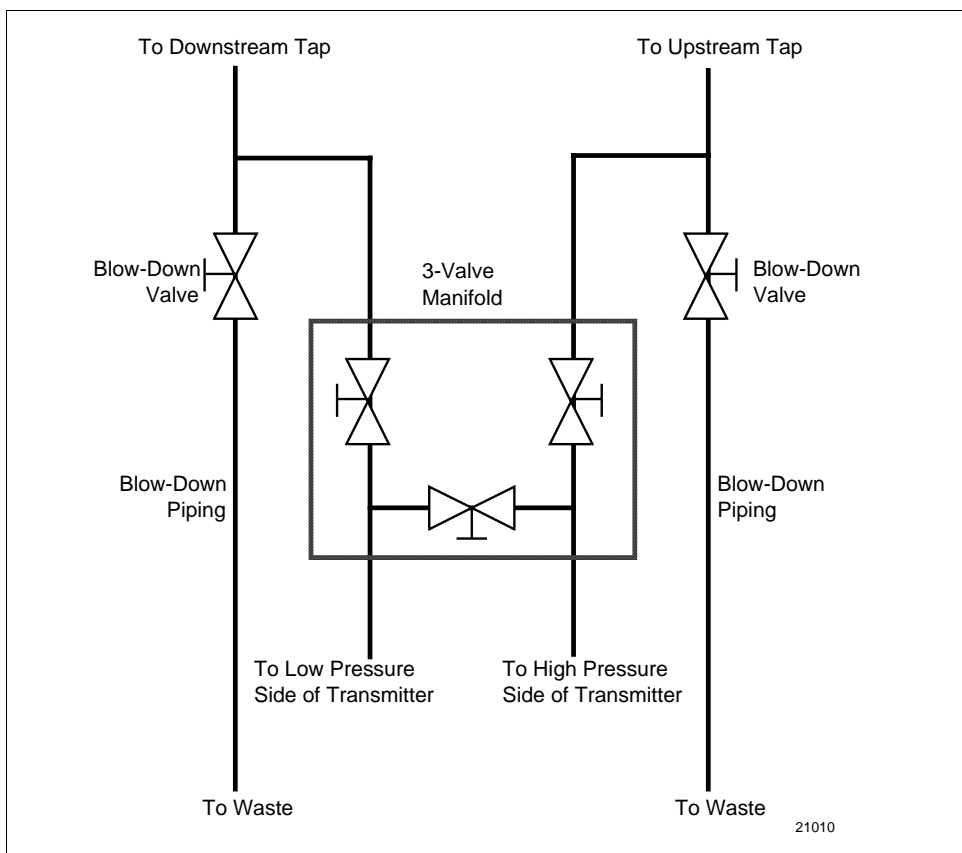

Continued on next page

4.3 Piping SMV 3000 Transmitter, Continued

Transmitter location

The suggested mounting location for the transmitter depends on the process to be measured. Figure 11 shows the transmitter located above the tap for gas flow measurement. This arrangement allows for condensate to drain away from the transmitter.

Figure 12 shows the transmitter located below the tap for liquid or steam flow measurement. This arrangement minimizes the static head effect of the condensate. Although the transmitter can be located level with or above the tap, this arrangement requires a siphon to protect the transmitter from process steam. (The siphon retains water as a “fill fluid.”)

Figure 11 Transmitter Location Above Tap for Gas Flow Measurement

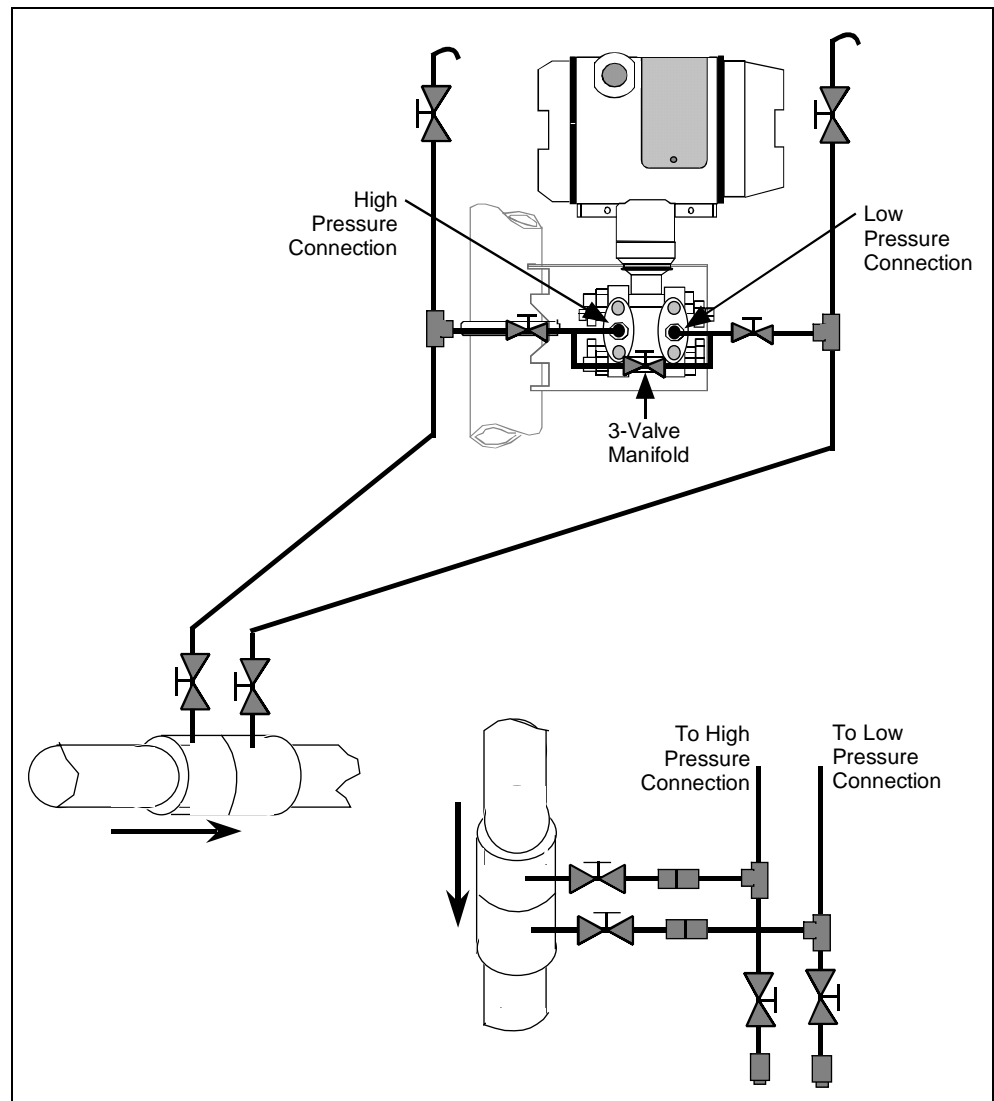

Continued on next page

4.3 Piping SMV 3000 Transmitter, Continued

Figure 12 Transmitter Location Below the Tap for Liquid or Steam Flow Measurement

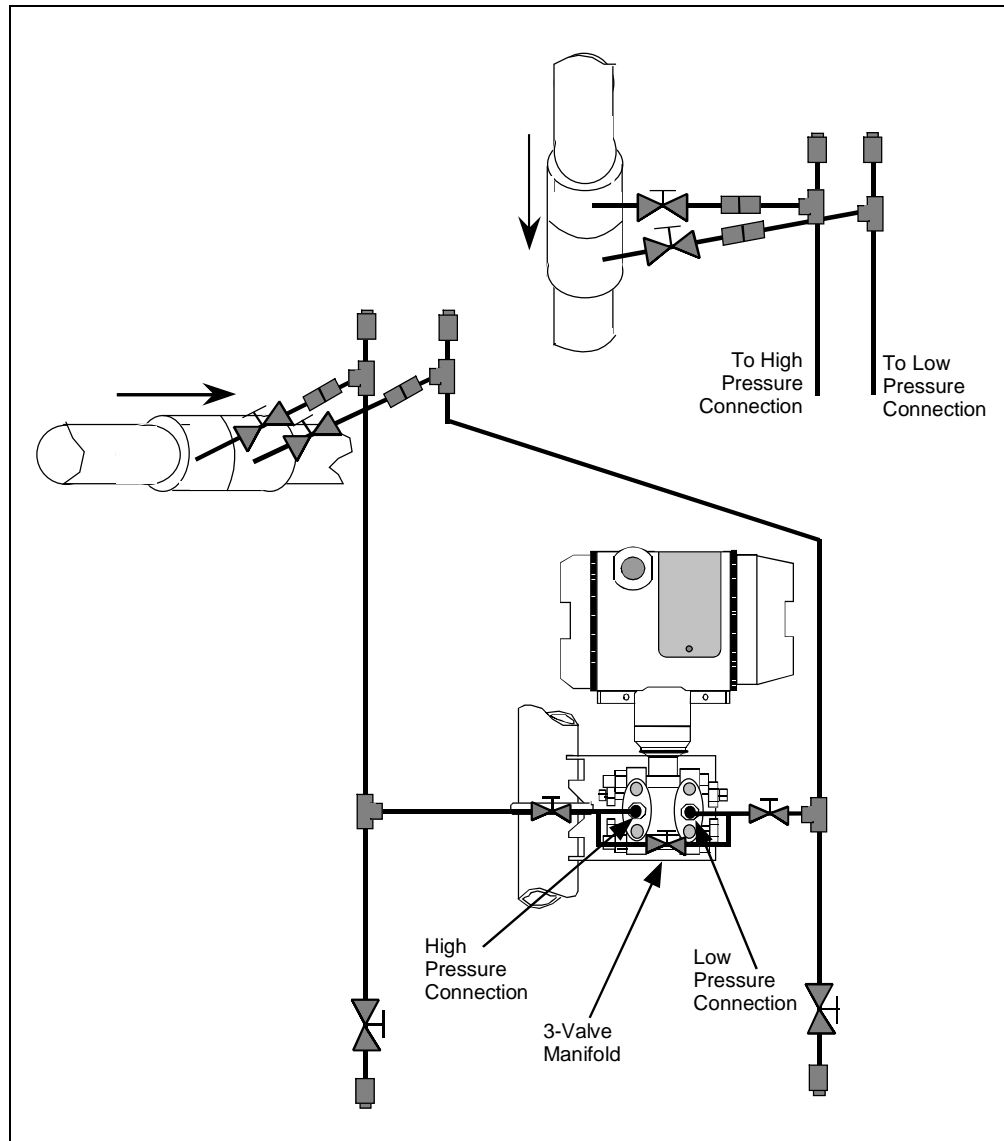

ATTENTION

For liquid or steam, the piping should slope a minimum of 25.4 mm (1 inch) per 305 mm (1 foot). Slope the piping down towards the transmitter if the transmitter is below the process connection so the bubbles may rise back into the piping through the liquid. If the transmitter is located above the process connection, the piping should rise vertically above the transmitter; then slope down towards the flow line with a vent valve at the high point. For gas measurement, use a condensate leg and drain at the low point (freeze protection may be required here).

Continued on next page

4.3 Piping SMV 3000 Transmitter, Continued

General piping guidelines

- When measuring fluids containing suspended solids, install permanent valves at regular intervals to blow-down piping.
 - Blow-down all lines on new installations with compressed air or steam and flush them with process fluids (where possible) before connecting these lines to the transmitter's meter body.
 - Be sure all the valves in the blow-down lines are closed tight after the initial blow-down procedure and each maintenance procedure after that.
-

Installing flange adapter

Table 6 gives the steps for installing an optional 1/2 inch NPT flange adapter on the process head.

ATTENTION

Slightly deforming the gasket supplied with the adapter before you insert it into the adapter may aid in retaining the gasket in the groove while you align the adapter to the process head. To deform the gasket, submerge it in hot water for a few minutes then firmly press it into its recessed mounting groove in the adapter.

Continued on next page

4.3 Piping SMV 3000 Transmitter, Continued

Installing flange adapter, continued

Table 6 Installing 1/2 inch NPT Flange Adapter

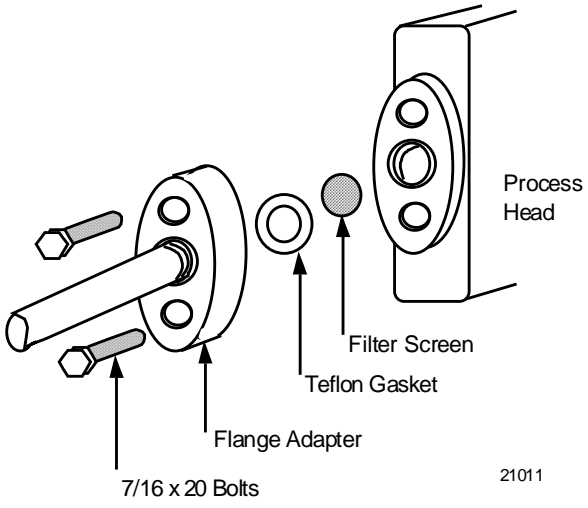
Step	Action
1	Insert filter screen (if supplied) into inlet cavity of process head.
2	Carefully seat Teflon (white) gasket into adapter groove.
3	Thread adapter onto 1/2-inch process pipe and align mounting holes in adapter with holes in end of process head as required.
4	<p>Secure adapter to process head by hand tightening 7/16-20 hex-head bolts.</p> <p>Example - Installing adapter on process head.</p>  <p style="text-align: right;">21011</p> <p>ATTENTION Apply an anti-seize compound on the stainless steel bolts prior to threading them into the process head.</p>
5	Evenly tighten adapter bolts to a torque of 47.5 to 54 N·m (35 to 40 ft-lb).

4.4 Installing RTD or Thermocouple

Considerations

You are responsible for installing the thermowell to house the RTD or thermocouple sensor. Be sure to use a spring-load accessory to hold the RTD sensor against the end of the thermowell.

To reduce the effects of “noise,” use shielded cable or run sensor leads in a conduit.

See the *Guide to Temperature Sensors and Thermowells, 34-44-29-01* which tells you how to properly specify thermal probes and thermowell assemblies for your application. Model selection guides also are included for various temperature probes.

CE Conformity Special Conditions (Europe)

You must use shielded cable to connect sensor to transmitter’s temperature circuit.

4.5 Wiring SMV 3000 Transmitter

CE Conformity Special Conditions (Europe)

You must use shielded, twisted-pair cable such as Belden 9318 for all signal/power wiring.

Summary

The transmitter is designed to operate in a two-wire power/current loop with loop resistance and power supply voltage within the operating range shown in Figure 13.

Figure 13 Operating Range for SMV 3000 Transmitters

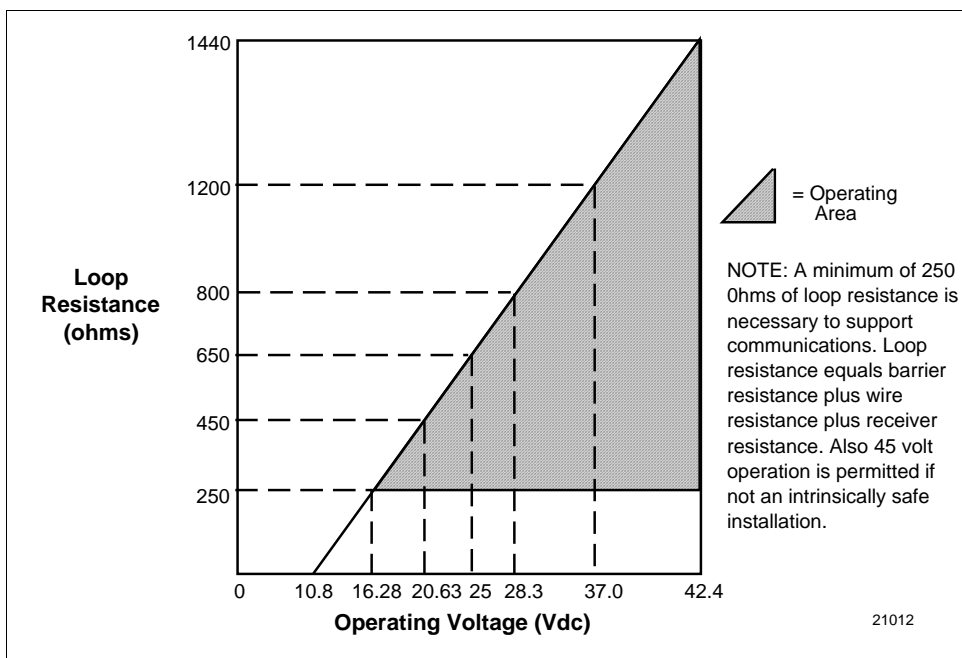

You simply connect the positive (+) and negative (-) loop wires to the positive (+) and negative (-) SIGNAL terminals on the terminal block in the transmitter's electronics housing shown in Figure 14.

Continued on next page

4.5 Wiring SMV 3000 Transmitter, Continued

Figure 14 SMV 3000 Transmitter Terminal Block

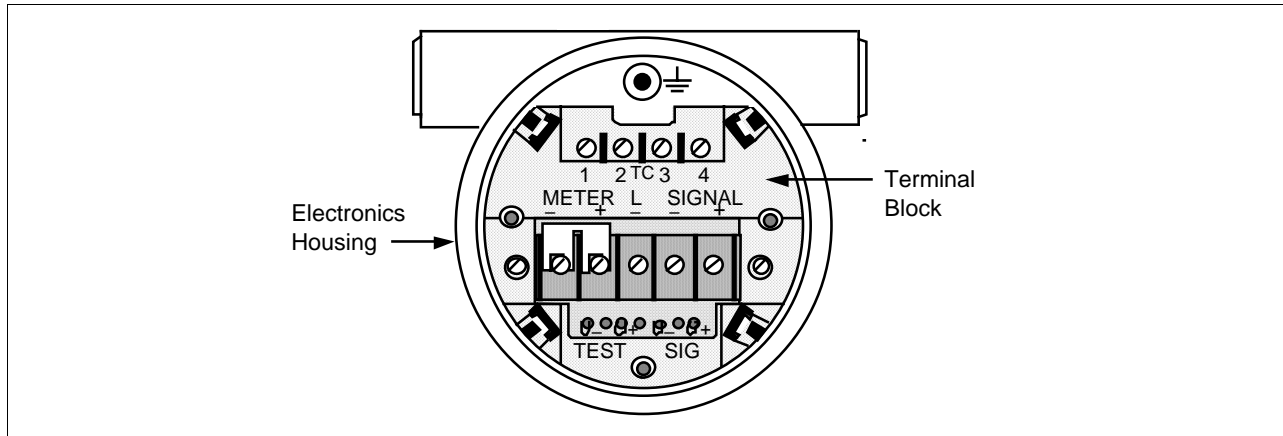

Summary, continued

You connect RTD leads to the TC terminals 1, 2, 3, and 4 as appropriate for the given probe type.

You connect thermocouple leads to terminals 1 (-) and 3 (+), observing polarity.

Each transmitter includes an internal ground terminal to connect the transmitter to earth ground or a ground terminal can be optionally added to the outside of the electronics housing. While it is not necessary to ground the transmitter for proper operation, we suggest that you do so to minimize the possible effects of “noise” on the output signal and provide additional protection against lightning and static discharge damage. Note that grounding may be required to meet optional approval body certification. Refer to section 1.2 CE Conformity (Europe) Notice for special conditions.

Transmitters are available with optional lightning protection if they will be used in areas highly susceptible to lightning strikes.

Barriers must be installed per manufacturer’s instructions for transmitters to be used in intrinsically safe installations (see control drawing 51404251 in Section 13 for additional information).

Continued on next page

4.5 Wiring SMV 3000 Transmitter, Continued

TPS/TDC 3000 reference

Transmitters that are to be digitally integrated to our TPS/TDC 3000 systems will be connected to the Smart Transmitter Interface Multivariable Module in the Process Manager, Advanced Process Manager, or High Performance Process Manager through a Field Termination Assembly. Details about the TPS/TDC 3000 system connections are given in the PM/APM Smartline Transmitter Integration Manual PM12-410 which is part of the TPS/TDC 30000 system bookset and in Appendix A of this manual.

Optional meter

The SMV 3000 transmitter can be equipped with an optional analog output meter.

The analog meter provides a 0 to 100% indication of the transmitter's output through traditional pointer and scale indication. It can be mounted integrally on top of the terminal block in the electronics housing with a meter end cap or remotely in a separate housing.

You connect the analog meter across the meter terminals on the terminal block with the metal jumper strap removed. For more detailed information on wiring the analog meter, refer to control drawing 51404251 (for intrinsically safe installations) and external wiring diagrams 51404250 and 51404251 (for non-intrinsically safe installations) in Section 13.

Wiring connections

The procedure in Table 7 shows the steps for connecting power/loop and temperature sensor input wiring to the transmitter. For loop wiring connections, refer to the control drawing 51404251 for intrinsically safe loops and external wiring diagrams 51404250 and 51404251 for non-intrinsically safe loops in Section 13 for details. If you are using the SMV transmitter with our TPS/TDC 3000 control systems, refer to the appropriate TPS/TDC 3000 manual or Appendix A in this manual.

ATTENTION

All wiring must be installed in accordance with the National Electrical Code (ANSI/NFPA 70) and local codes and regulations.

Table 7 Wiring the Transmitter

Step	Action
1	Loosen end-cap lock and remove electronic housing end-cap cover.
2	If transmitter is supplied with an optional integral meter, unsnap meter from terminal block to expose wiring connections.

Continued on next page

4.5 Wiring SMV 3000 Transmitter, Continued

Wiring connections,
continued

Table 7 Wiring the Transmitter, Continued

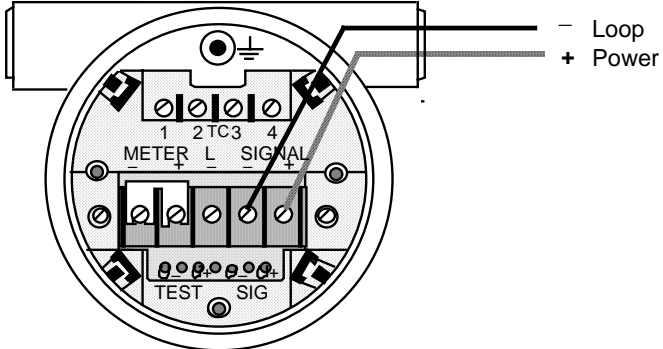
Step	Action										
3	<p>Feed temperature sensor input leads through conduit entrance in housing. Strip 1/4 inch (6.35 mm) of insulation from input leads.</p> <table border="1" data-bbox="686 485 1450 936"> <thead> <tr> <th data-bbox="686 485 1049 527">If input is from ...</th> <th data-bbox="1049 485 1450 527">Then...</th> </tr> </thead> <tbody> <tr> <td data-bbox="686 527 1049 621">2-wire RTD</td> <td data-bbox="1049 527 1450 621">connect RTD leads to terminals 1 and 3. See Figure 15.</td> </tr> <tr> <td data-bbox="686 621 1049 716">3-wire RTD</td> <td data-bbox="1049 621 1450 716">connect RTD leads to terminals 1, 2, and 3. See Figure 15.</td> </tr> <tr> <td data-bbox="686 716 1049 831">4-wire RTD</td> <td data-bbox="1049 716 1450 831">connect RTD leads to terminals 1, 2, 3, and 4. See Figure 16.</td> </tr> <tr> <td data-bbox="686 831 1049 936">2-wire Thermocouple</td> <td data-bbox="1049 831 1450 936">connect minus (-) lead to terminal 1 and plus (+) lead to terminal 3. See Figure 16.</td> </tr> </tbody> </table>	If input is from ...	Then...	2-wire RTD	connect RTD leads to terminals 1 and 3. See Figure 15.	3-wire RTD	connect RTD leads to terminals 1, 2, and 3. See Figure 15.	4-wire RTD	connect RTD leads to terminals 1, 2, 3, and 4. See Figure 16.	2-wire Thermocouple	connect minus (-) lead to terminal 1 and plus (+) lead to terminal 3. See Figure 16.
If input is from ...	Then...										
2-wire RTD	connect RTD leads to terminals 1 and 3. See Figure 15.										
3-wire RTD	connect RTD leads to terminals 1, 2, and 3. See Figure 15.										
4-wire RTD	connect RTD leads to terminals 1, 2, 3, and 4. See Figure 16.										
2-wire Thermocouple	connect minus (-) lead to terminal 1 and plus (+) lead to terminal 3. See Figure 16.										
4	<p>Feed loop power leads through conduit entrance on other side of electronics housing opposite RTD wiring entrance.</p> <p>ATTENTION The transmitter accepts up to 16 AWG (1.5 mm diameter) wire.</p>										
5	<p>Strip 1/4 inch (6.35 mm) of insulation from leads. Observing polarity, connect positive loop power lead to SIGNAL + terminal and negative loop power lead to SIGNAL - terminal.</p> <p>Example - Connecting loop power to transmitter.</p> 										
6	<p>If you have an optional analog meter, be sure jumper strap is removed from across METER terminals, yellow lead from meter is connected to METER - terminal and red lead is connected to METER + terminal. See control drawing 51404251 (for intrinsically safe installations) or wiring diagram 51404250 (non-intrinsically safe) included in Section 13.</p>										

Continued on next page

4.5 Wiring SMV 3000 Transmitter, Continued

Wiring connections,
continued

Table 7 Wiring the Transmitter, Continued

Step	Action
7	Replace integral meter, if applicable; replace end-cap, and tighten end-cap lock.

Figure 15 RTD Input Wiring Connections.

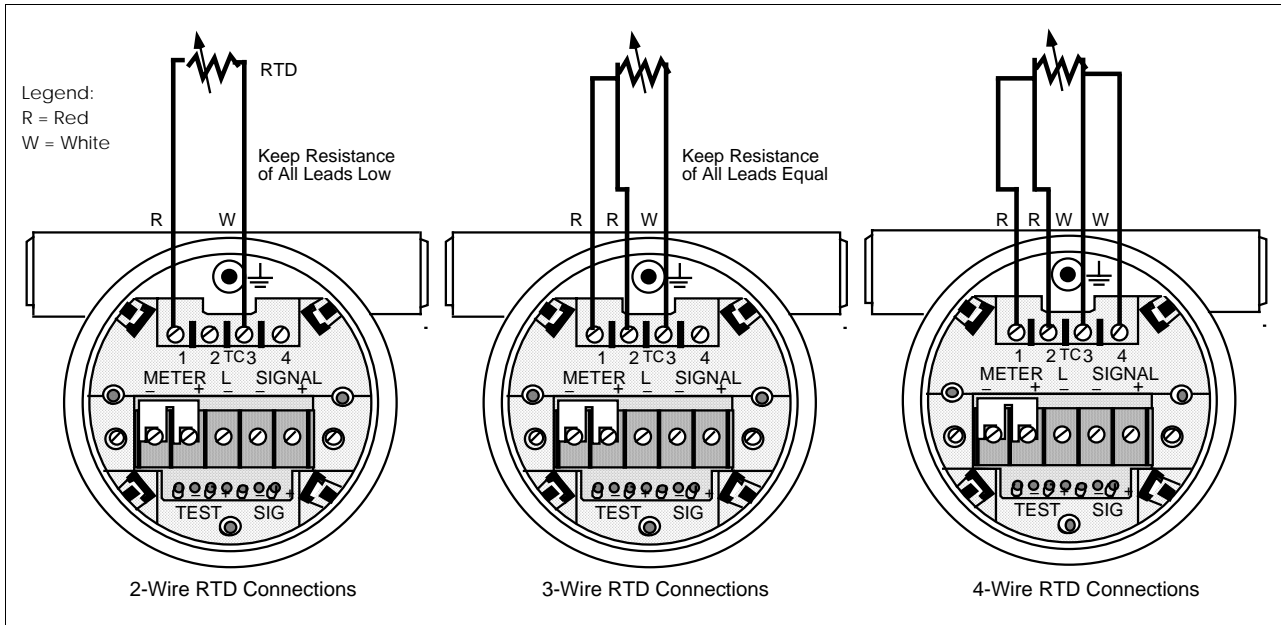
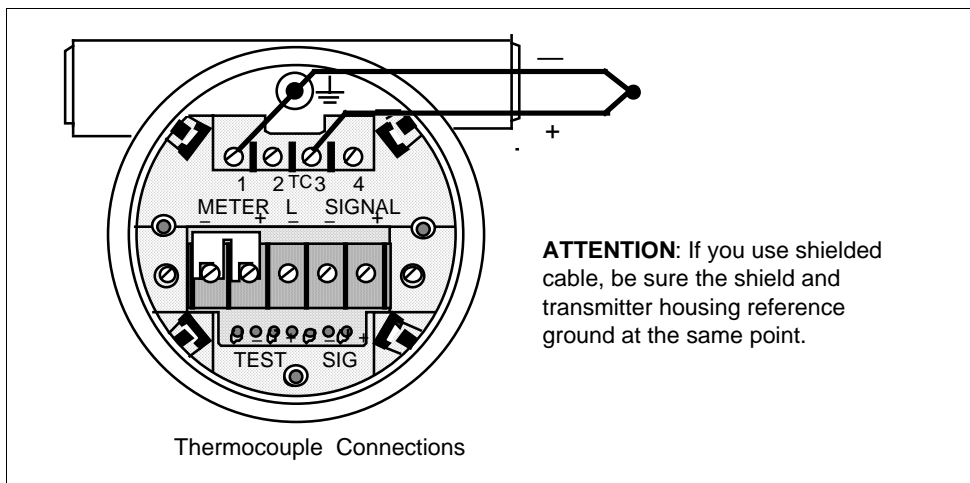

Figure 16 Thermocouple Input Wiring Connections.



Continued on next page

4.5 Wiring SMV 3000 Transmitter, Continued

Lightning protection

When your transmitter is equipped with optional lightning protection, you must connect a wire from the transmitter to ground as shown in Figure 17 to make the protection effective. We recommend that you use a size 8 AWG (American Wire Gauge) or KCM (Kilo Circular Mils) bare or Green covered wire.

Note that protection for temperature sensor leads is **not** provided by the optional lightning protection.

Figure 17 Ground Connection for Lightning Protection

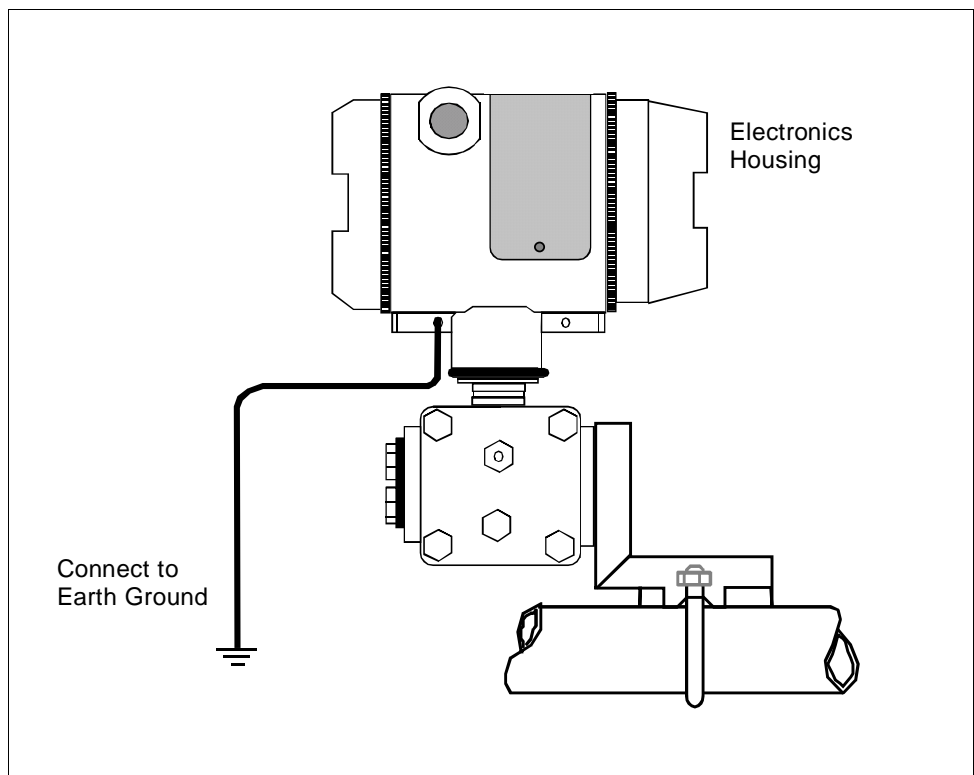

4.5 Wiring SMV 3000 Transmitter, Continued

Conduit seals and Hazardous Location Installations

Transmitters installed as explosionproof in a Class I, Division 1, Group A Hazardous (Classified) Location in accordance with ANSI/NFPA 70, the US National Electrical Code (NEC), require a “LISTED” explosionproof seal to be installed in the conduit, within 18 inches of the transmitter.

Crouse-Hinds® type EYS/EYD or EYSX/EYDX are examples of “LISTED” explosionproof seals that meets this requirement.

Transmitters installed as explosionproof in a Class I, Division 1, Group B, C or D Hazardous (Classified) Locations do not require an explosionproof seal to be installed in the conduit.

NOTE: Installation should conform to all national and local electrical code requirements.

WARNING

When installed as explosionproof in a Division 1 Hazardous Location, keep covers tight while the transmitter is energized. Disconnect power to the transmitter in the non-hazardous area prior to removing end caps for service.

When installed as nonincendive equipment in a Division 2 Hazardous Location, disconnect power to the transmitter in the non-hazardous area, or determine that the location is non-hazardous prior to disconnecting or connecting the transmitter wires.

Section 5 —Getting Started

5.1 Introduction

Section Contents

This section includes these topics

Topic	See Page
5.1 Introduction	37
5.2 Establishing Communications	38
5.3 Making Initial Checks	42
5.4 Write Protect Option.....	43

About This Section

If you have never used an SCT to “talk” to an SMV 3000 transmitter, this section tells you how to connect the SMV with the SCT, establish on-line communications and make initial checks.

ATTENTION

The SCT 3000 contains on-line help and an on-line user manual providing complete instructions for using the SCT to setup and configure SMV transmitters.

5.2 Establishing Communications

Off-line Versus On-line SMV Configuration

The SCT 3000 allows you to perform both off-line and on-line configuration of SMV transmitters.

- Off-line configuration does not require connection to the transmitter. By operating the SCT 3000 in the off-line mode, you can configure database files of an unlimited number of transmitters prior to receipt, save them either to hard disk or a floppy diskette, and then download the database files to the transmitters during commissioning.
- An on-line session requires that the SCT is connected to the transmitter and allows you to download previously-configured database files at any time during installation or commissioning of your field application. Note that you can also upload a transmitter's existing configuration and then make changes directly to that database.

Off-line Configuration Procedures

Refer to the SCT User Manual (on-line) for detailed procedures on how to off-line configure SMV transmitters using the SCT 3000.

SCT Hardware Connections

A PC or laptop computer (host computer) which contains the SCT software program, is connected to the wiring terminals of the SMV transmitter and other smart field devices. Figure 18 shows the hardware components of the SCT.

Figure 18 SCT Hardware Components

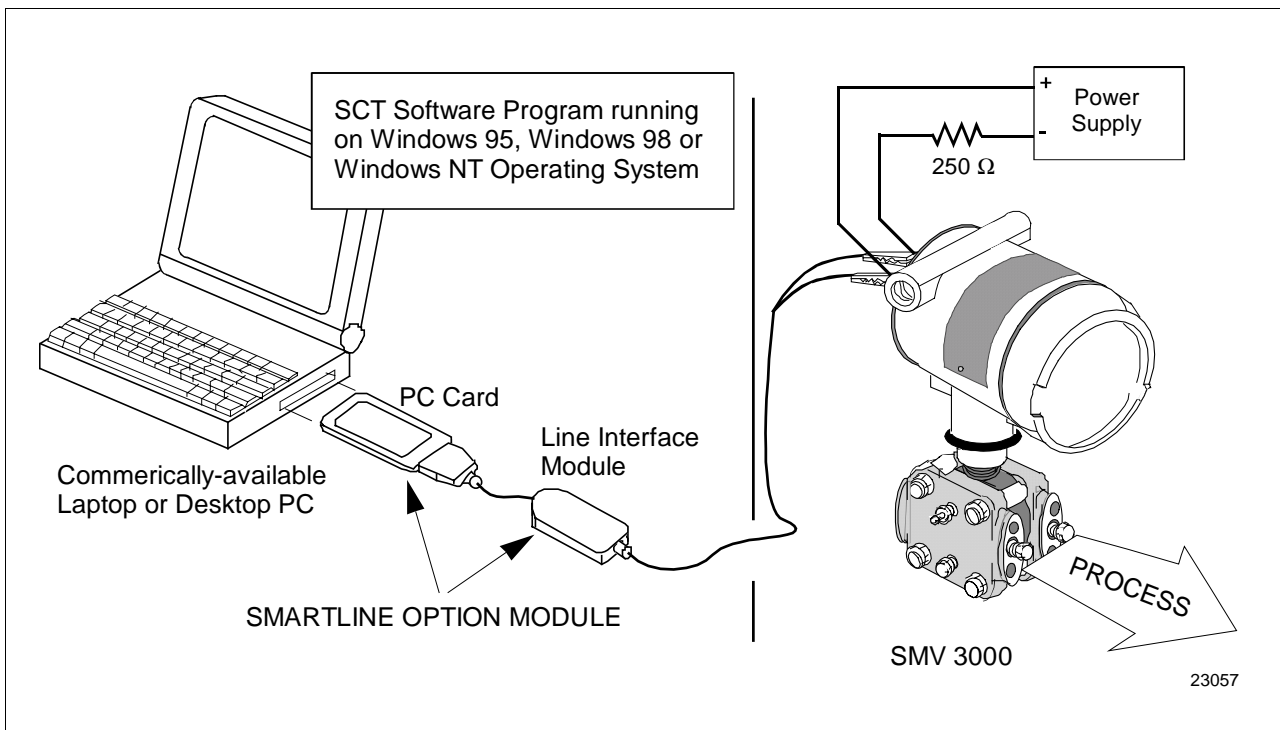

Continued on next page

5.2 Establishing Communications, Continued

ATTENTION

Connecting the host computer to an SMV for on-line communications requires Smartline Option Module consisting of a PC Card and Line Interface Module.

SCT 3000 On-line Connections to the SMV

Table 8 provides the steps to connect the assembled SCT 3000 hardware between the host computer and the SMV for on-line communications.

WARNING

When the transmitter's end-cap is removed, the housing is not explosionproof.

Table 8 Making SCT 3000 Hardware Connections

Step	Action
<p>1</p>	<p>With the power to the host computer turned off, insert the PC Card into the type II PCMCIA slot on the host computer (see Figure 5-1).</p> <p>ATTENTION To use the SCT 3000 in a desktop computer without a PCMCIA slot, you must install a user-supplied PCMCIA host adapter. Honeywell has performance-qualified the following PCMCIA host adapters for use with the SCT:</p> <ul style="list-style-type: none"> -- TMB-240 Single Slot Internal Front Panel Adapter -- TMB-250 Dual Slot Internal Front Panel Adapter -- GS-120 Greystone Peripherals, Inc. -- GS-320 Greystone Peripherals, Inc. <p>CAUTION Do not insert a PC Card into a host computer's PCMCIA slot while the host computer is powered on.</p>
<p>2</p>	<p>Remove the end-cap at the terminal block side of the SMV and connect the easy hooks or alligator clips at the end of the adapter cable to the respective terminals on the SMV as follows:</p> <ul style="list-style-type: none"> • Connect the red lead to the positive terminal. • Connect the black lead to the negative terminal. <p>ATTENTION The SCT 3000 can be connected to only one SMV at a time.</p>

Continued on next page

5.2 Establishing Communications, Continued

Establishing On-line Communications with the SMV

Table 9 lists the steps to begin an on-line session with the loop-connected SMV and upload the database configuration from the transmitter.

Table 9 Making SCT 3000 On-line Connections

Step	Action
1	Make sure that 24V dc power is applied to the proper SMV transmitter SIGNAL terminals. See Subsection 4.5, Wiring SMV 3000 Transmitter for details.
2	Apply power to the PC or laptop computer and start the SCT 3000 application.
3	Perform either step 4A (recommended) or 4B (but not both) to upload the current database configuration from the SMV.
4A	<ul style="list-style-type: none"> • Select Tag ID from the View Menu (or click on the Tag ID toolbar button) to access the View Tag dialog box. -- If the SCT 3000 detects that the transmitter is in analog mode, a dialog box displays prompting you to put the loop in manual and to check that all trips are secured (if necessary) before continuing. Click OK to continue. -- After several seconds, the SCT 3000 reads the device's tag ID and displays it in the View Tag dialog box. • Click on the Upload button in the View Tag dialog box to upload the current database configuration from the SMV and make the on-line connection. -- A Communications Status dialog box displays during the uploading process.
4B	<p>Select Upload from the Device Menu (or click on the Upload toolbar button) to upload the current database configuration from the SMV and make the on-line connection.</p> <ul style="list-style-type: none"> -- If the SCT 3000 detects that the transmitter is in analog mode, a dialog box displays prompting you to put the loop in manual and to check that all trips are secured (if necessary) before continuing. Click OK to continue. -- A Communications Status dialog box displays during the uploading process.

Continued on next page

5.2 Establishing Communications, Continued

Making On-line Connections to the SMV, continued

Table 9 Making SCT 3000 On-line Connections, Continued

Step	Action
5	<p>When the on-line view of the SMV appears on the screen, access the Status form by clicking on its tab. The Status form is used to verify the status of the connected field device.</p> <ul style="list-style-type: none">• Separate list boxes for Gross Status and Detailed Status are presented in the Status form. Refer to the SCT 3000 User Manual (on-line) for explanations of each status condition.
6	Refer to the SCT 3000 User Manual (on-line) for a procedure on how to download any previously-saved configuration database files.

5.3 Making Initial Checks

Checking Communication Mode and Firmware Version

Before doing anything else, it is a good idea to confirm the transmitter's mode of operation and identify the version of firmware being used in the transmitter.

- Communication mode (either ANALOG or DE mode) is displayed on the Status Bar at the bottom SCT application window.
 - The transmitter's firmware version is displayed on the Device configuration form.
-

DE Communication Mode

A transmitter in the digital (DE) mode can communicate in a direct digital fashion with a Universal Station in Honeywell's TPS and TDC 3000 control systems. The digital signal can include all four transmitter process variables and its secondary variable as well as the configuration database.

Changing Communication Mode

You can select the mode you want the transmitter to communicate with the control system. The communication mode is selected in the SCT General Configuration form tab card.

5.4 Write Protect Option

Write Protect Option The SMV 3000 transmitters are available with a “write protect option”. It consists of a jumper located on the transmitter’s Main Printed Circuit Board (PCB) under the temperature measurement (Daughter) PCB that you can position to allow read and write access or read only access to the transmitter’s configuration database. When the jumper is in the read only position, you can only read/view the transmitter’s configuration and calibration data. Note that the factory default jumper position is for read and write access. There is no need to check jumper position unless you want to change it.

Figure 19 shows the location of the write protect jumper on the electronics module for SMV 3000 transmitters.

Figure 19 Write Protect Jumper Location and Selections with Daughter PCB Removed.

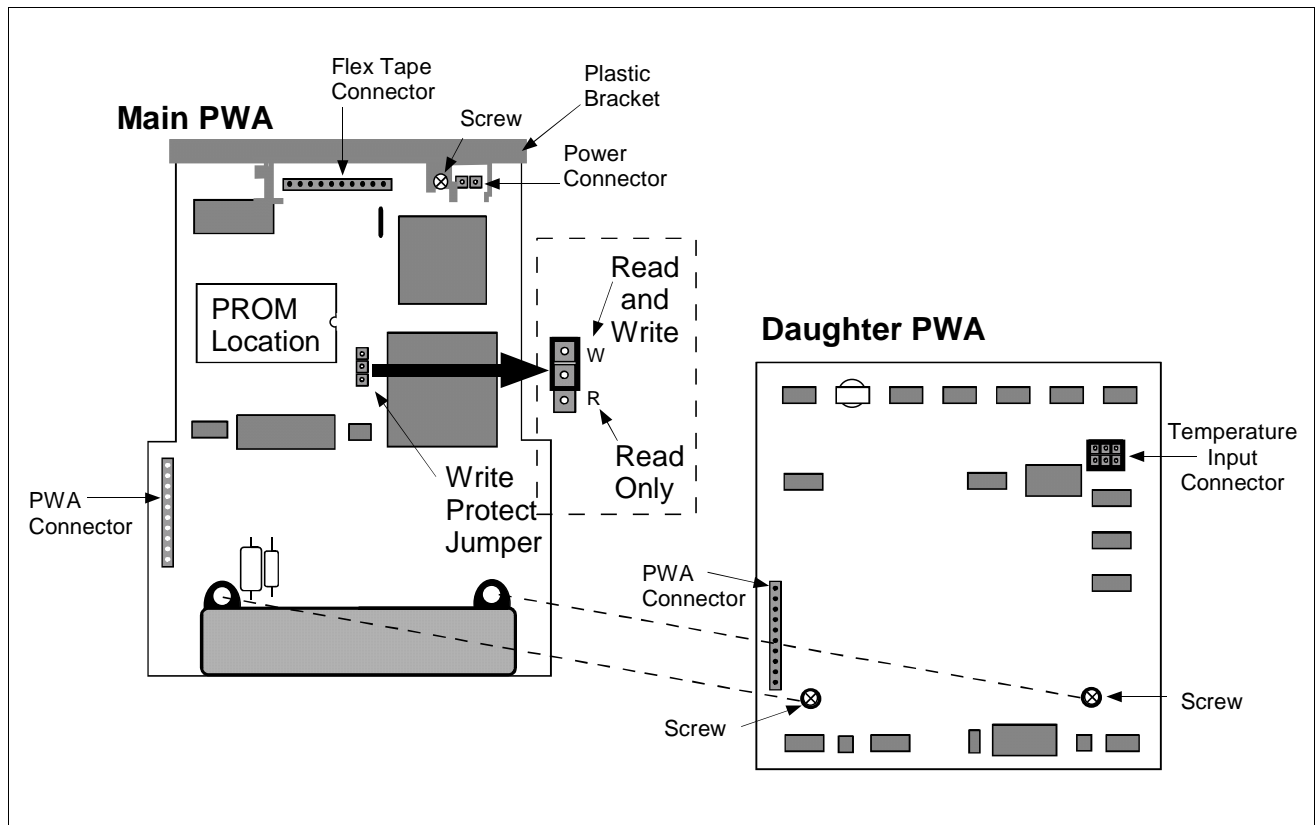

Section 6 — Configuration

6.1 Introduction

Section Contents

This section includes these topics

Topic	See Page
6.1 Introduction	45
6.2 Overview	47
6.3 Configuring the SMV 3000 with The SCT	49
6.4 <i>Device</i> Configuration	50
6.5 <i>General</i> Configuration	51
6.6 <i>DPCConf</i> Configuration - PV1.....	54
6.7 <i>AP/GPCConf</i> Configuration - PV2.....	59
6.8 <i>TempConf</i> Configuration - PV3	61
6.9 <i>FlowConf</i> Configuration - PV4	68
6.10 Flow Compensation Wizard.....	74
6.11 Using Custom Engineering Units.....	75
6.12 Saving, Downloading and Printing a Configuration File	77
6.13 Verifying Flow Configuration	78

About This Section

This section introduces you to SMV 3000 transmitter configuration. It identifies the parameters that make up the transmitter's configuration database and provides information for entering values/selections for the given configuration parameters using the SCT.

Continued on next page

6.1 Introduction, Continued

ATTENTION

Please verify that you have the SCT software version that is compatible with your SMV 3000. Refer to the table on Page 1.

To check the software version, connect an SFC or SCT to the transmitter, (see Figure 28 for typical SFC and SCT connections).

Using the SCT: Perform Upload of the SMV database to the SCT. The SMV firmware version can be read from the *Device* tab card.

To check the SCT software version, select About SCT from the Help pull down menu. The software version will be displayed.

Using the SFC: Press **SHIFT** and **ID** keys. Wait for upload of transmitter configuration to SFC.

Then press **SHIFT** and **3**. The software version for the SFC and SMV will be displayed.

SCT On-line Help and User Manuals

IMPORTANT: While the information presented in this section refers to SMV 3000 transmitter configuration using the SCT 3000 software program, the SCT on-line manual and help topics contain complete information and procedures on SMV 3000 configuration and should be followed to properly configure the transmitter.

This section of the manual should be viewed as subordinate to the SCT on-line manual and if inconsistencies exist between the two sources, the SCT on-line manual will prevail.

Supplemental reference information is presented in this section.

To Print On-line Manual and Help Topics

The sections of the SCT on-line manual and help topics can be printed out for your reference.

1. Select Contents or User Manual from the Help pull down menu of the SCT application window.
 2. Go to the Contents tab.
 3. Select a section or topic you wish to print out.
 4. Click on the Print . . . button.
-

6.2 Overview

About Configuration

Each SMV 3000 Transmitter includes a configuration database that defines its particular operating characteristics. You use the SCT 3000 to enter and change selected parameters within a given transmitter's database to alter its operating characteristics. We call this process of viewing and/or changing database parameters "configuration".

SMV configuration can be done using the SCT either on-line, where configuration parameters are written to the SMV through a direct connection with the SCT, or off-line where the transmitter configuration database is created and saved to disk for later downloading to the SMV. Figure 20 shows a graphic summary of the on-line configuration process.

Figure 20 SMV On-line Configuration Process

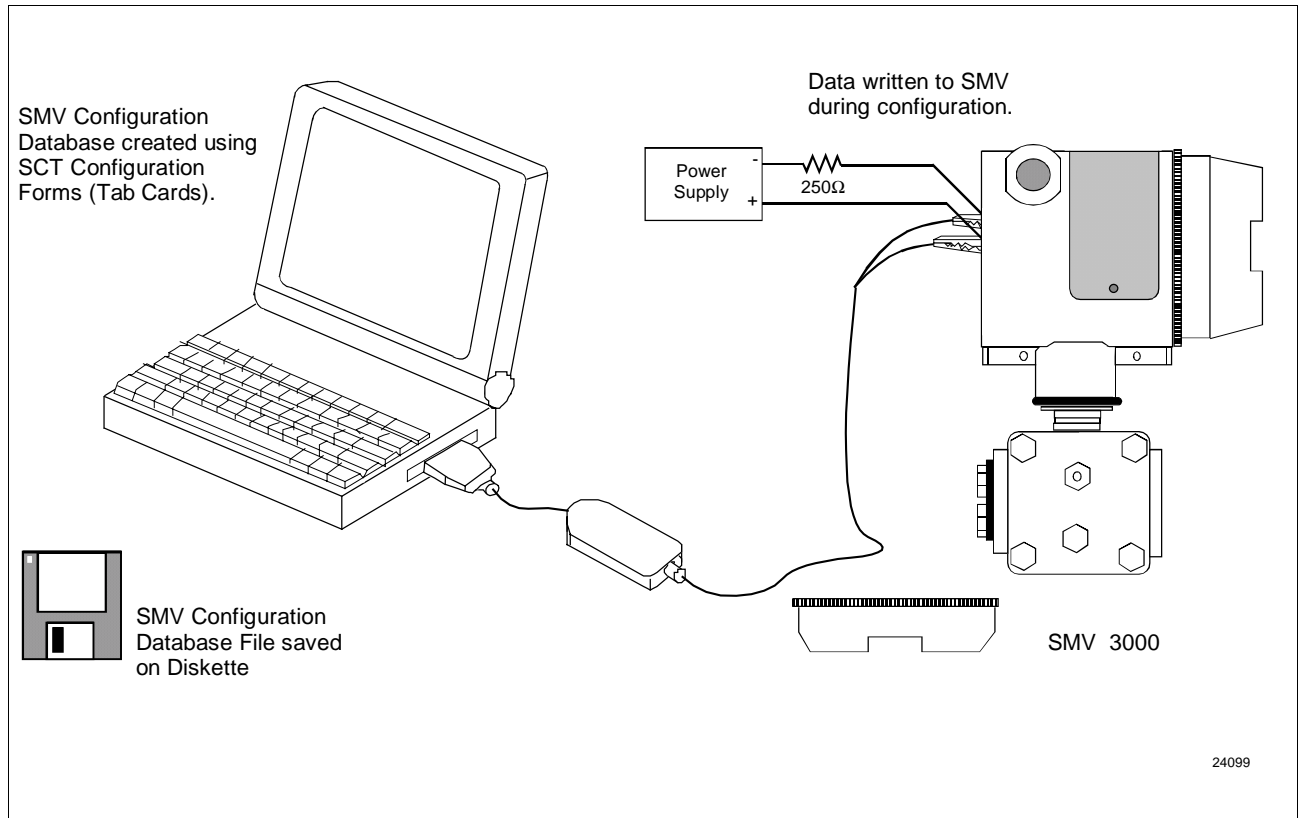

Configuration Summary

The SCT contains templates that you can use to create configuration database for various smart field devices. The SMV templates contain the configuration forms (or tab cards) necessary to create the database for an SMV transmitter.

Continued on next page

6.2 Overview, Continued

Configuration Summary, continued

When using a Honeywell-defined SMV template, you should choose a file template for the temperature range and model of SMV that you wish to configure.

For example, if the SMV transmitter is a **model SMA125** and you are using a **J-type thermocouple** as the process temperature PV3 input, you would choose the template file **sma125j.hdt** from the list of Honeywell templates. You would then enter the configuration parameters in the fields of the tab cards displayed in the SCT window.

Configuration is complete when you have entered all parameters in the template's tab cards, (and for flow applications you have entered all flow data in the flow compensation wizard). You then save the template file containing the SMV transmitter's database as a disk file.

SMV 3000 /SCT Connections

Refer to Section 5.2 Establishing Communications or the SCT on-line user manual for connecting the SCT and SMV for on-line configuration.

SFC and SMV 3000 Configuration

We **do not** recommend that you configure the SMV using the Smart Field Communicator (SFC). Some of the advanced functions of the SMV transmitter are not supported by the SFC. However you can use the SFC to perform certain operations, such as calibrate or re-range the transmitter, read transmitter status and diagnose faults.

6.3 Configuring the SMV 3000 with The SCT

Using the SCT for SMV 3000 Configuration

The SCT template files have tab cards that contain data fields for the SMV parameters which you fill in. You start with the Device tab card to enter the device tag name (Tag ID) and other general descriptions. Next, you can select each tab card in order and configure each PV (PV1, secondary variable if desired, PV2, PV3, and PV4).

SMV Process Variable	SCT Template Tab Card
PV1 (Differential Pressure)	DPCConf
PV2 (Absolute Pressure or Gauge Pressure) *	APConf or GPConf *
PV3 (Process Temperature)	TempConf
PV4 (Flow)	FlowConf

* PV2 will be AP or GP depending on SMV model

Use the Flow Compensation Wizard to setup the SMV 3000 for flow applications. The flow wizard guides you through the steps necessary to complete your flow configuration. See Subsection 6.10 and Appendix C for more information about the flow wizard.

In the subsections below information is given for filling in some of the SCT tab card data fields. Supplementary background information and reference data on SMV configuration that may be helpful is also presented. Use the SCT on-line help and user manual for detailed “how to configure” information.

ATTENTION

If the transmitter detects an incomplete database upon power-up, it will initialize the database parameters to default conditions. A setting or selection with a superscript “^d” in the following subsections identifies the factory setting.

6.4 Device Configuration

Transmitter Tag Name and PV1 Priority

Tag ID field is found on the *Device* tab card.

Tag ID - Enter an appropriate tag name for the transmitter containing up to eight ASCII characters which uniquely identifies the transmitter.

NOTE: It is suggested that when you create a database configuration file for the transmitter, you make the file name the same as the transmitter tag ID.

PV1 Priority - Enter “/” slash as the eighth character in tag number to set PV1 as “priority” PV in DE (digital) data broadcast, if all four PVs are selected for broadcast (turned ON). See “Selecting PVs for Broadcast” on next page for an explanation on the broadcast of PVs.

Background

Normally, PV1 has the number 1 priority unless all four PVs are selected for broadcast. Then, PV4 has the number 1 priority, PV1 is second, PV2 is third, and PV3 is fourth. However, you can set PV1 to have the top priority and PV4 to be second by entering a “/” as the eighth character in the Tag ID.

Note that the transmission rate for the various PVs depends on the number of PVs that are selected for broadcast. When more than one PV is selected, the “priority” PV is sent every other broadcast cycle.

Device Data Fields

See the SCT help and on-line user manual for descriptions and procedures for filling in the remaining data fields of the *Device* tab card.

6.5 General Configuration

PV Type

The PV Type field is found on the *General* tab card.

Selecting PVs for Broadcast

Select one of the PV Types in Table 10 to choose which of the transmitter's PVs are to be sent (broadcast) to the control system. Optionally, you can select whether the secondary variable (SV1) is included as part of the broadcast message. The secondary is the SMV transmitter's meter body temperature.

NOTE: This configuration parameter is valid only when the transmitter is in DE mode.

Table 10 PV Type Selection for SMV Output

If You Select PV Type . . .	These PVs are Broadcast to Control System
PV1 (DP)	Differential Pressure (PV1) measurement.
PV1 (DP) and PV2 (SP)	Differential Pressure (PV1) and Static Pressure* (PV2) measurements.
PV1 (DP) - PV3 (TEMP)	Differential Pressure (PV1), Static Pressure* (PV2) and Process Temperature (PV3) measurements.
PV1 (DP) - PV4 (FLOW)	Differential Pressure (PV1), Static Pressure* (PV2) and Process Temperature (PV3) measurements and the Calculated flow rate value (PV4).
PV1 (DP) w/SV1 (M.B.Temp)	Differential Pressure (PV1) measurement with the Secondary Variable (SV1).
PV1 (DP) w/SV1 & PV2 (SP)	Differential Pressure (PV1) and Static Pressure* (PV2) measurements with the Secondary Variable (SV1).
PV1 (DP) w/SV1 - PV3 (TEMP)	Differential Pressure (PV1), Static Pressure* (PV2) and Process Temperature (PV3) measurements with the Secondary Variable (SV1).
PV1 (DP) w/SV1 - PV4 (FLOW)	Differential Pressure (PV1), Static Pressure* (PV2) and Process Temperature (PV3) measurements and the Calculated flow rate value (PV4) with the Secondary variable (SV1).

* Static pressure may be absolute or gauge pressure, depending on the SMV model type. (For models SMA110 and SMA125, PV2 measures absolute pressure. For model SMG170, PV2 measures gauge pressure.)

Continued on next page

6.5 General Configuration, Continued

Background

You can select which of the transmitter's Process Variables (PVs) are to be broadcast as part of the transmitter's digital transmission to the control system. You also can select whether the secondary variable is included as part of the broadcast message.

ATTENTION

To digitally integrate the SMV 3000 transmitter with our TPS/TDC control systems, you must have an STIMV IOP module in your Process Manager, Advanced Process Manager, or High Performance Process Manager. You can not integrate the SMV 3000 with a control system using an STDC card or an STI IOP module for the Smart Transmitter interface.

Contact your Honeywell representative for information about possibly upgrading an existing STI IOP to an STIMV IOP.

Analog Output Selection

The Analog Output Selection field should contain the PV type that will represent the transmitter's output when the transmitter is in its analog mode.

Select the PV you want to see as the SMV output from the choices in Table 11.

Table 11 SMV Analog Output Selection

Determine which PV is desired as SMV Output . . .	Then Select...
PV1 – Delta P (Differential Pressure)	PV1 (DP)
PV2 – Static (Absolute or Gauge Pressure)	PV2 (SP)*
PV3 – Proc Temp (Process Temperature)	PV3 (Temp)
PV4 – Calculated (Calculated Flow Rate)	PV4 (Flow) ^d

^d Factory setting.

* Static pressure may be absolute or gauge pressure, depending on the SMV model type. (For models SMA110 and SMA125, PV2 measure absolute pressure. For model SMG170, PV2 measures gauge pressure.)

Background

A transmitter output can represent only one process variable when it is operating in its analog mode. You can select which one of the four PVs is to represent the output.

Continued on next page

6.5 **General Configuration,** Continued

Line Filter

When using the process temperature (PV3) input, select the input filter frequency that matches the power line frequency for the power supply.

- 50 Hz
- 60 Hz^d

^d Factory setting.

Background

The line filter helps to eliminate noise on the process temperature signal input to the transmitter. Make a selection to indicate whether the transmitter will work with a 50 Hz or 60 Hz line frequency.

6.6 *DPCConf* Configuration - PV1

Engineering Units The *DPCConf* tab card displays the Low Range Value (LRV), Low Range Limit (LRL), Upper Range Value (URV) and Upper Range Limit (URL) for PV1 in the unit of measure selected in the Engineering Units field.

PV1 Engineering Units Select one of the preprogrammed engineering units in Table 12 for display of the PV1 measurements.

Table 12 Pre-programmed Engineering Units for PV1

Engineering Unit	Meaning
inH2O @ 39F ^d	Inches of Water at 39.2 °F (4 °C)
inH2O @ 68F	Inches of Water at 68 °F (20 °C)
mmHg @ 0C	Millimeters of Mercury at 0°C (32 °F)
psi	Pounds per Square Inch
kPa	Kilopascals
MPa	Megapascals
mbar	Millibar
bar	Bar
g/cm ²	Grams per Square Centimeter
Kg/cm ²	Kilograms per Square Centimeter
inHg @ 32F	Inches of Mercury at 32 °F (0 °C)
mmH2O @ 4C	Millimeters of Water at 4°C (39.2 °F)
mH2O @ 4C	Meters of Water at 4 °C (39.2 °F)
ATM	Normal Atmospheres
inH2O @ 60F	Inches of Water at 60 °F (15.6 °C)

^d Factory setting.

Continued on next page

6.6 *DPCConf* Configuration - PV1, Continued

LRV and URV

The Lower Range Value and the Upper Range Value fields for PV1 are found on the *DPCConf* tab card.

PV1 (DP) Range Values

Set the LRV (which is the process input for 4 mA dc* (0%) output) and URV (which is the process input for 20 mA dc* (100%) output) for the differential pressure input PV1 by typing in the desired values on the SCT configuration .

- LRV = Type in the desired value (default = 0.0)
- URV = Type in the desired value
(default = 100 inH₂O@39.2 °F for SMV models SMA125 and SMG170)
(default = 10 inH₂O@39.2 °F for SMV models SMA110)

* When transmitter is in analog mode.

ATTENTION

- SMV 3000 Transmitters are calibrated with inches of water ranges using inches of water pressure referenced to a temperature of 39.2 °F (4 °C).
 - For a reverse range, enter the upper range value as the LRV and the lower range value as the URV. For example, to make a 0 to 50 inH₂O range a reverse range, enter 50 as the LRV and 0 as the URV.
 - The URV changes automatically to compensate for any changes in the LRV and maintain the present span (URV – LRV).
 - If you must change both the LRV and URV, always change the LRV first.
-

Continued on next page

6.6 DPConf Configuration - PV1, Continued

Output Conformity

Select the output form for differential pressure (PV1) variable to represent one of these selections. Note that calculated flow rate process variable (PV4) includes a square root operation and it is not affected by this selection.

- LINEAR^d
- SQUARE ROOT

^d Factory setting.

Background

The PV1 output is normally set for a straight linear calculation since square root is performed for PV4. However, you can select the transmitter's PV1 output to represent a square root calculation for flow measurement. Thus, we refer to the linear or the square root selection as the output conformity or the output form for PV1.

About Square Root Output

For SMV 3000 transmitters measuring the pressure drop across a primary element, the flow rate is directly proportional to the square root of the differential pressure (PV1) input. The PV1 output value is automatically converted to equal percent of root DP when PV1 output conformity is configured as square root.

You can use these formulas to manually calculate the percent of flow for comparison purposes.

- $100 = \%P$

Where, ΔP = Differential pressure input in engineering units
 Span = Transmitter's measurement span (URV – LRV)
 $\%P$ = Pressure input in percent of span

Therefore, $\sqrt{\frac{\%P}{100}} \cdot 100 = \% \text{ Flow}$

And, you can use this formula to determine the corresponding current output in milliamperes direct current.

$$(\% \text{ Flow} \cdot 16) + 4 = \text{mA dc Output}$$

Continued on next page

6.6 DPConf Configuration - PV1, Continued

About Square Root Output, continued

Example: If you have an application with a differential pressure range of 0 to 100 inches of water with an input of 49 inches of water, substituting into the above formulas yields:

$$\frac{49}{100} \cdot 100 = 49\%$$

$$\sqrt{\frac{49\%}{100}} \cdot 100 = 70\% \text{ Flow, and}$$

$$70\% \cdot 16 + 4 = 15.2 \text{ mA dc Output}$$

Square Root Dropout

To avoid unstable output at PV1 readings near zero, the SMV 3000 transmitter automatically drops square root conformity and changes to linear conformity for low differential pressure readings. As shown in Figure 21, the square root dropout point is between 0.4 and 0.5 % of differential pressure input.

Figure 21 Square Root Dropout Points for PV1

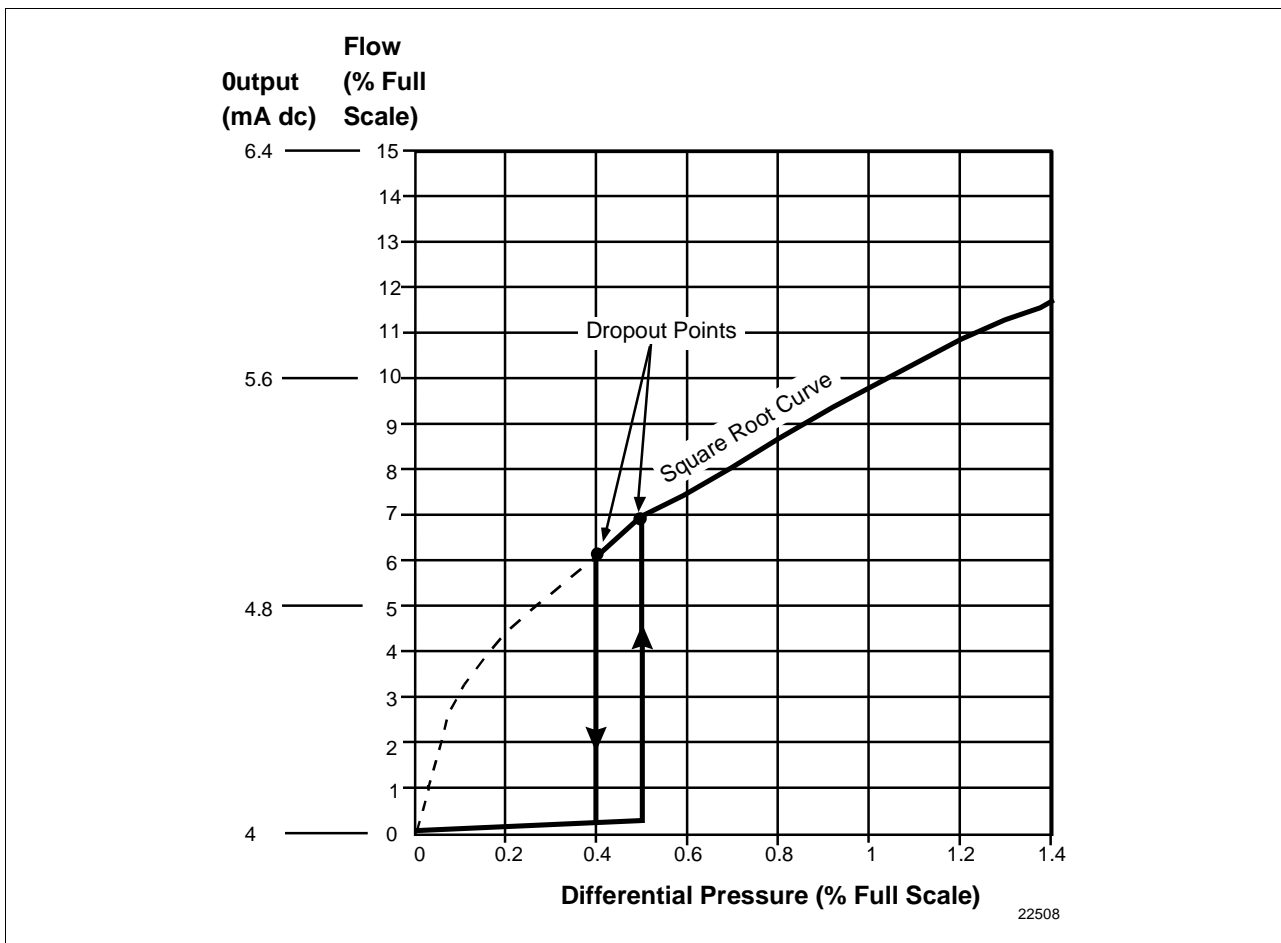

Continued on next page

6.6 **DPCConf Configuration - PV1**, Continued

Damping

Adjust the damping time constant for Differential Pressure (PV1) to reduce the output noise. We suggest that you set the damping to the smallest value that is reasonable for the process.

The damping values (in seconds) for PV1 are:

0.00^d, 0.16, 0.32, 0.48,
1.0, 2.0, 4.0, 8.0, 16.0, and 32.0

^d Factory setting.

Background

The electrical noise effect on the output signal is partially related to the turndown ratio of the transmitter. As the turndown ratio increases, the peak-to-peak noise on the output signal increases. You can use this formula to find the turndown ratio using the pressure range information for your transmitter.

$$\text{Turndown Ratio} = \frac{\text{Upper Range Limit}}{(\text{Upper Range Value} - \text{Lower Range Value})}$$

Example: The turndown ratio for a 400 inH₂O transmitter with a range of 0 to 50 inH₂O would be:

$$\text{Turndown Ratio} = \frac{400}{(50 - 0)} = \frac{8}{1} \text{ or } 8:1$$

6.7 AP/GPConf Configuration - PV2

Engineering Units

The *AP/GPConf* tab card displays the Low Range Value (LRV), Low Range Limit (LRL), Upper Range Value (URV) and Upper Range Limit (URL) for PV2 in the unit of measure selected in the Engineering Units field.

NOTE: Depending on the SMV transmitter model type, PV2 will measure static pressure in either absolute or gauge values.

SMV Models —SMA110 and SMA125 PV2 —Absolute Pressure
 —STG170 PV2 —Gauge Pressure

PV2 Engineering Units

Select one of the preprogrammed engineering units in Table 13 for display of the PV2 measurements.

Table 13 Pre-programmed Engineering Units for PV2*

Engineering Unit	Meaning
inH2O @ 39F	Inches of Water at 39.2 °F (4 °C)
inH2O @ 68F	Inches of Water at 68 °F (20 °C)
mmHg @ 0C	Millimeters of Mercury at 0°C (32 °F)
psi ^d	Pounds per Square Inch
kPa	Kilopascals
MPa	Megapascals
mbar	Millibar
bar	Bar
g/cm ²	Grams per Square Centimeter
Kg/cm ²	Kilograms per Square Centimeter
inHg @ 32F	Inches of Mercury at 32 °F (0 °C)
mmH2O @ 4C	Millimeters of Water at 4°C (39.2 °F)
mH2O @ 4C	Meters of Water at 4 °C (39.2 °F)
ATM	Normal Atmospheres
inH2O @ 60F	Inches of Water at 60 °F (15.6 °C)

^d Factory setting.

* Static pressure may be absolute or gauge pressure, depending on the SMV model type.

Atmospheric Offset

For SMV models SMG170, (which uses gauge pressure as PV2 input), you must measure the absolute static pressure and then enter that value in the Atmospheric Offset field.

Continued on next page

6.7 AP/GPConf Configuration - PV2, Continued

Background

Internally, the SMV transmitter uses absolute pressure values for all flow calculations. The value entered in the Atmospheric Offset field is added to the gauge pressure input value to approximate the absolute pressure. An inaccurate atmospheric pressure offset value will result in a small error of the flow calculation.

Use an absolute pressure gauge to measure the correct atmospheric pressure. A standard barometer may not give an accurate absolute pressure reading.

PV2 (AP/GP or SP) Range Values (LRV and URV)

The Lower Range Value and the Upper Range Value fields for PV2 are found on the *AP/GPConf* tab card.

Set the LRV (which is the process input for 0% output and URV (which is the process input for 100% output for the static pressure input PV2 by typing in the desired values on the SCT tab card.

- LRV = Type in the desired value (default = 0.0)
- URV = Type in the desired value
(default = 50 psia for model SMA110)
(default = 750 psia for model SMA125)
(default = 3000 psig for model SMG170)

NOTE: Static pressure may be absolute or gauge pressure, depending on the model SMV 3000 you have selected.

ATTENTION

- The range for PV2 is static pressure (as measured at the high pressure port of the meter body).
- The URV changes automatically to compensate for any changes in the LRV and maintain the present span (URV – LRV).
- If you must change both the LRV and URV, always change LRV first.

Damping

Adjust the damping time constant for Static Pressure (PV2) to reduce the output noise. We suggest that you set the damping to the smallest value that is reasonable for the process. The damping values (in seconds) for

PV2 are: 0.00^d, 0.16, 0.32, 0.48,
1.0, 2.0, 4.0, 8.0, 16.0, and 32.0

^d Factory setting.

Background

The electrical noise effect on the output signal is partially related to the turndown ratio of the transmitter. As the turndown ratio increases, the peak-to-peak noise on the output signal increases. See the Damping paragraphs in subsection 6.6 for a formula to find the turndown ratio using the pressure range information for your transmitter.

6.8 TempConf Configuration - PV3

Engineering Units

The *TempConf* tab card displays the Low Range Value (LRV), Low Range Limit (LRL), Upper Range Value (URV) and Upper Range Limit (URL) for PV3 in the unit of measure selected in the Engineering Units field.

Selecting PV3 Engineering Units

Select one of the preprogrammed engineering units in Table 14 for display of the PV3 measurements, depending upon output characterization configuration.

Also select one of the preprogrammed engineering units for display of the cold junction temperature readings (CJT Units field). This selection is independent of the other sensor measurements. See Cold Junction Compensation on next page.

Table 14 Pre-programmed Engineering Units for PV3

Engineering Unit	Meaning
C ^d	Degrees Celsius or Centigrade
F	Degrees Fahrenheit
K	Kelvin
R	Degrees Rankine
NOTE: When output characterization configuration for PV3 is NON-LINEAR (see Output Characterization), PV3 input readings are displayed in the following units:	
mV or V	milliVolts or Volts (for Thermocouple sensor)
Ohm	Ohms (for RTD sensor)

^d Factory setting.

Continued on next page

6.8 TempConf Configuration - PV3, Continued

Cold Junction Compensation

If a thermocouple is used for process temperature PV3 input, you must select if the cold junction (CJ) compensation will be supplied internally by the transmitter or externally from a user-supplied isothermal block.

Specify source of cold junction temperature compensation.

- Internal
 - External - Must also key in value of cold junction temperature for reference.
-

Background

Every thermocouple requires a hot junction and a cold junction for operation. The hot junction is located at the point of process measurement and the cold junction is located in the transmitter (internal) or at an external location selected by the user. The transmitter bases its range measurement on the difference of the two junctions. The internal or external temperature sensitive resistor compensates for changes in ambient temperature that would otherwise have the same effect as a change in process temperature.

If you configure CJ source as external, you must tell the transmitter what cold junction temperature to reference by typing in the temperature as a configuration value. For internal cold junction configuration, the transmitter measures the cold junction temperature internally.

Output Linearization

For process temperature (PV3) input, configure output to represent one of these characterization selections.

- Linear^d - Output is in percent of temperature span.
- Unlinearized - Output is in percent of resistance span for RTD or millivolts or volts span for T/C.

^d Factory setting.

Background

You can have the transmitter provide a linear output which is linearized to temperature for PV3 input, or a nonlinear output which is proportional to resistance for an RTD input, or millivolt or volt input for T/C input. Also, if you do switch from linear to unlinearized or vice versa, be sure you verify the LRV and URV settings after you enter the configuration data.

Continued on next page

6.8 TempConf Configuration - PV3, Continued

Sensor Type

Identify and select the type of sensor that is connected to the transmitter as its input for process temperature PV3. This will set the appropriate LRL and URL data in the transmitter automatically.

Table 15 shows the pre-programmed temperature sensor types and the rated measurement range limits for a given sensor selection.

Table 15 Sensor Types for PV3 Process Temperature Input

Sensor Type	Rated Temperature Range Limits	
	°C	°F
PT100 D ^d	-200 to 450	-328 to 842
Type E	0 to 1000	32 to 1832
Type J	0 to 1200	32 to 2192
Type K	-100 to 1250	-148 to 2282
Type T	-100 to 400	-148 to 752

^d Factory setting.

ATTENTION

Whenever you connect a different sensor as the transmitter's input, you must also change the sensor type configuration to agree. Otherwise, range setting errors may result.

6.8 TempConf Configuration - PV3, Continued

T/C Fault Detect

Select whether to turn on the function for T/C or RTD fault detection.

- ON – Any RTD or T/C lead breakage initiates a critical status flag.
- OFF^d – Break in RTD sensing lead or any T/C lead initiates a critical status flag.

^d Factory setting.

Background

You can turn the transmitter's temperature sensor fault detection function ON or OFF through configuration.

- With the detection ON, the transmitter drives the PV3 output to failsafe in the event of an open RTD or T/C lead condition. The direction of the failsafe indication (upscale or downscale) is determined by the failsafe jumper on the PWA, (See Subsection 8.3).
 - When fault detection is set to OFF, these same failsafe conditions result in the transmitter for an open RTD **sensing** lead or any T/C lead. But when an open RTD **compensation** lead is detected, the transmitter automatically reconfigures itself to operate without the compensation lead. This means that a 4-wire RTD would be reconfigured as 3-wire RTD, if possible and thus avoiding a critical status condition in the transmitter when the transmitter is still capable of delivering a reasonably accurate temperature output.
-

Continued on next page

6.8 TempConf Configuration - PV3, Continued

PV3 (Temperature) Range Values (LRV and URV)

The Lower Range Value and the Upper Range Value fields for PV3 are found on the *TempConf* tab card.

Set the LRV and URV (which are desired zero and span points for your measurement range) for the process temperature input PV3 by typing in the desired values on the *TempConf* tab card.

- LRV = Type in the desired value (default = 0.0)
- URV = Type in the desired value (default = URL)

Background

You can set the LRV and URV for PV3 by either typing in the desired values on the *SCT TempConf* tab card or applying the corresponding LRV and URV input signals directly to the transmitter. The LRV and URV set the desired zero and span points for your measurement range as shown the example in Figure 22.

Figure 22 Typical Range Setting Values for PV3

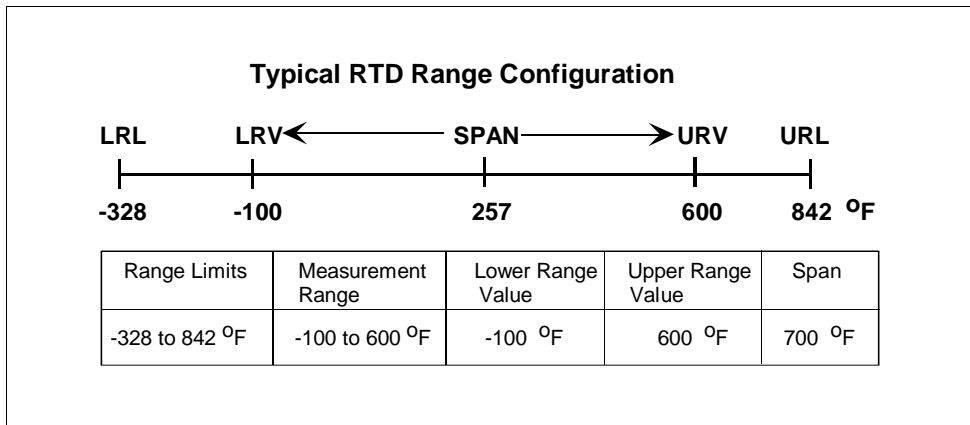

NOTE: LRL and URL values are set automatically when you select the sensor type in the Sensor Type field.

Continued on next page

6.8 TempConf Configuration - PV3, Continued

ATTENTION

- For a reverse range, enter the upper range value as the LRV and the lower range value as the URV. For example, to make a 0 to 500 °F range a reverse range, enter 500 as the LRV and 0 as the URV.
- The URV changes automatically to compensate for any changes in the LRV and maintain the present span (URV – LRV). See Figure 23 for an example.
- If you must change both the LRV and URV, always change the LRV first. However, if the change in the LRV would cause the URV to exceed the URL, you would have to change the URV to narrow the span before you could change the LRV

Figure 23 Example of LRV and URV Interaction

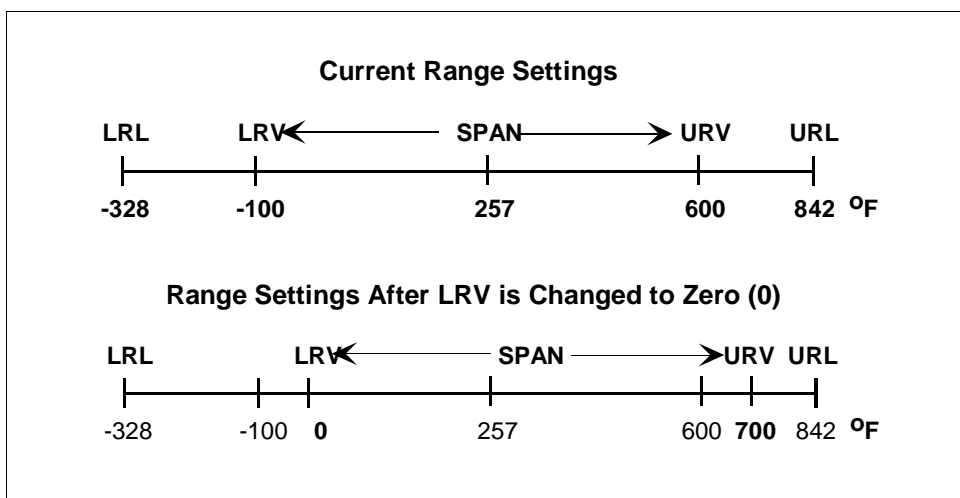

Continued on next page

6.8 *TempConf* Configuration - PV3, Continued

Damping

Adjust the damping time constant for Process Temperature (PV3) to reduce the output noise. We suggest that you set the damping to the smallest value that is reasonable for the process.

The damping values (in seconds) for PV3 are:

0.00^d, 0.3, 0.7, 1.5, 3.1, 6.3,
12.7, 25.5, 51.1, 102.3

^d Factory setting.

Background

The electrical noise effect on the output signal is partially related to the turndown ratio of the transmitter. As the turndown ratio increases, the peak-to-peak noise on the output signal increases. See the Damping paragraphs in subsection 6.6 for a formula to find the turndown ratio using the pressure range information for your transmitter.

6.9 FlowConf Configuration - PV4

Engineering Units The *FlowConf* tab card displays the Low Range Value (LRV), Low Range Limit (LRL), Upper Range Value (URV) and Upper Range Limit (URL) for PV4 in the unit of measure selected in the Engineering Units field.

PV4 Engineering Units Select one of the preprogrammed engineering units for display of the PV4 measurements, depending upon type of flow measurement configuration. Table 16 lists the pre-programmed engineering units for volumetric flow and Table 17 lists the engineering units for mass flow.

Table 16 Pre-programmed Volumetric Flow Engineering Units for PV4

Engineering Unit	Meaning
M ³ /h ^d	Cubic Meters per Hour
gal/h	Gallons per Hour
l/h	Liters per Hour
cc/h	Cubic Centimeters per Hour
m ³ /min	Cubic Meters per Minute
gal/min	Gallons per Minute
l/min	Liters per Minute
cc/min	Cubic Centimeters per Minute
m ³ /day	Cubic Meters per Day
gal/day	Gallons per Day
Kgal/day	Kilogallons per Day
bbl/day	Barrels per Day
m ³ /sec	Cubic Meters per Second
CFM *	Cubic Feet per Minute
CFH *	Cubic Feet per Hour

^d Factory setting.

* The SCT 3000 will not display SCFM, SCFH, ACFM or ACFH. However you can configure the SMV 3000 to calculate and display the volumetric flowrate at standard conditions (CFM or CFH) by choosing standard volume in the Flow Compensation Wizard. Likewise, you can choose actual volume for applications when you want to calculate volumetric flowrate at actual conditions.

Continued on next page

6.9 *FlowConf* Configuration - PV4, Continued

PV4 Engineering Units, continued

Table 17 Pre-programmed Mass Flow Engineering Units for PV4

Engineering Unit	Meaning
Kg/min	Kilograms per minute
lb/min	Pounds per Minute
Kg/h	Kilograms per Hour
lb/h	Pounds per Hour
Kg/sec	Kilograms per Second
lb/sec	Pounds per Second
t/h ^d	Tonnes per Hour (Metric Tons)
t/min	Tonnes per Minute (Metric Tons)
t/sec	Tonnes per Second (Metric Tons)
g/h	Grams per Hour
g/min	Grams per Minute
g/sec	Grams per Second
ton/h	Tons per Hour (Short Tons)
ton/min	Tons per Minute (Short Tons)
ton/sec	Tons per Second (Short Tons)

^d Factory setting.

Continued on next page

6.9 **FlowConf Configuration - PV4**, Continued

PV4 (Flow) Upper Range Limit (URL) and Range Values (LRV and URV)

Set the URL, LRV, and URV for calculated flow rate PV4 output by typing in the desired values on the *FlowConf* tab card.

- URL = Type in the maximum range limit that is applicable for your process conditions. (100,000 = default)
 - LRV = Type in the desired value (default = 0.0)
 - URV = Type in the desired value (default = URL)
-

ATTENTION

Be sure that you set the PV4 Upper Range Limit (URL) to desired value before you set PV4 range values. We suggest that you set the PV4 URL to equal two times the maximum flow rate (2 x URV).

About URL and LRL

The Lower Range Limit (LRL) and Upper Range Limit (URL) identify the minimum and maximum flow rates for the given PV4 calculation. The LRL is fixed at zero to represent a no flow condition. The URL, like the URV, depends on the calculated rate of flow that includes a scaling factor as well as pressure and/or temperature compensation. It is expressed as the maximum flow rate in the selected volumetric or mass flow engineering units.

Continued on next page

6.9 FlowConf Configuration - PV4, Continued

About LRV and URV

The LRV and URV set the desired zero and span points for your calculated measurement range as shown in the example in Figure 24.

Figure 24 Typical Volumetric Flow Range Setting Values

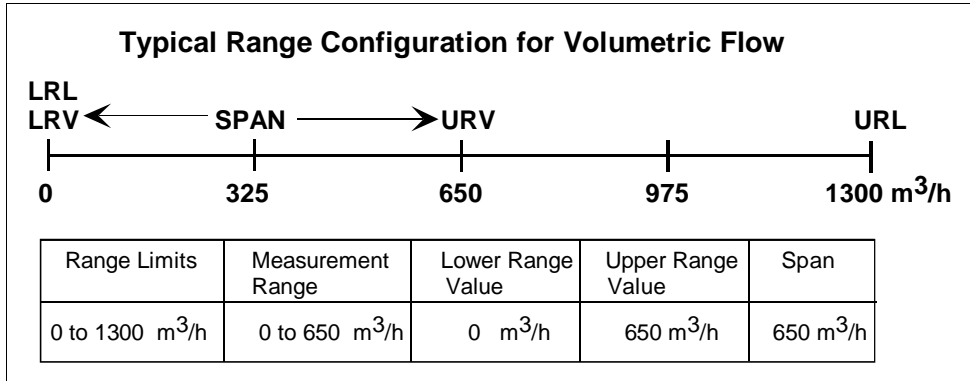

ATTENTION

- The default engineering units for volumetric flow rate is cubic meters per hour and tonnes per hour is the default engineering units for mass flow rate.
- The URV changes automatically to compensate for any changes in the LRV and maintain the present span (URV – LRV).
- If you must change both the LRV and URV, always change the LRV first.

Continued on next page

6.9 **FlowConf Configuration - PV4**, Continued

Damping

Adjust the damping time constant for flow measurement (PV4) to reduce the output noise. We suggest that you set the damping to the smallest value that is reasonable for the process.

The damping values (in seconds) for PV4 are:

0.00^d, 0.5, 1.0, 2.0, 3.0, 4.0, 5.0,
10.0, 50.0 and 100.0

^d Factory setting.

ATTENTION

The electrical noise effect on the output signal is partially related to the turndown ratio of the transmitter. As the turndown ratio increases, the peak-to-peak noise on the output signal increases. See the Damping paragraphs in subsection 6.6 for a formula to find the turndown ratio using the pressure range information for your transmitter.

Low Flow Cutoff for PV4

For calculated flow rate (PV4), set low and high cutoff limits between 0 and 30% of Upper Range Limit for PV4 in engineering units.

- Low Flow Cutoff: Low (0.0 = default)
High (0.0 = default)
-

Background

You can set low and high low flow cutoff limits for the transmitter output based on the calculated variable PV4. The transmitter will clamp the current output at zero percent flow when the flow rate reaches the configured low limit and will keep the output at zero percent until the flow rate rises to the configured high limit. This helps avoid errors caused by flow pulsations in range values close to zero. Note that you configure limit values in selected engineering units between 0 to 30% of the upper range limit for PV4.

Figure 25 gives a graphic representation of the low flow cutoff action for sample low and high limits in engineering units of liters per minute.

ATTENTION

If the flow LRV is not zero, the low flow cutoff output value will be calculated on the LRV and will not be 0 %.

Continued on next page

6.9 FlowConf Configuration - PV4, Continued

Figure 25 Graphic Representation of Sample Low Flow Cutoff Action.

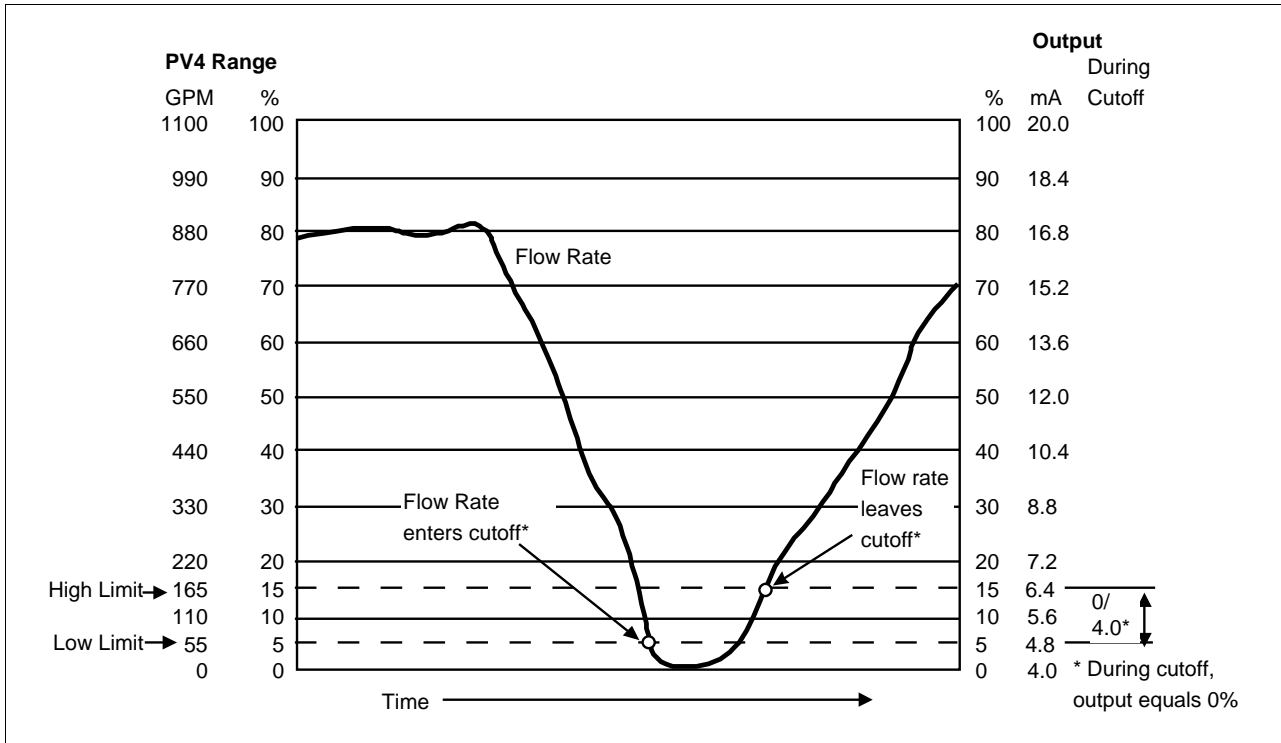

ATTENTION

The low flow cutoff action also applies for reverse flow in the negative direction. For the sample shown in Figure 25, this would result in a low limit of -55 GPM and a high limit of -165 GPM.

Continued on next page

6.10 Using Custom Engineering Units

Using Custom Units for PV4 Flow Measurement

The SCT contains a selection of preprogrammed engineering units that you can choose to represent your PV4 flow measurement. If you want the PV4 measurement to represent an engineering unit that is not one of the preprogrammed units stored in the SCT, you must select custom units and enter a tag that identifies the desired custom unit.

Using the SCT, selecting Custom Units allows you to choose a unit that is compatible with your application process. Additionally, a conversion factor must be calculated and entered when configuring the PV4 flow variable. This conversion factor is a value used to convert the standard units used by the SMV into the desired custom units. The standard units used by the SMV are:

- Tonnes/hour – for mass flow
- Meters³/hour – for volumetric flow

For example, to calculate the conversion factor for a volumetric flow rate of Standard Cubic Feet per Day – SCFD

$$Flow\ in\ SCFD = \left(Flow\ in\ \frac{m^3}{hr} \right) \left[\left(\frac{ft}{0.3048m} \right)^3 \cdot \left(\frac{24\ hr}{1\ day} \right) \right] = Flow\ in\ \frac{m^3}{hr} \cdot 847.552$$

$$Conversion\ Factor = 847.552$$

For example, to calculate the conversion factor for a mass flow rate of Kilograms per day – kg/day

$$Flow\ in\ kg/d = \left(Flow\ in\ \frac{t}{hr} \right) \left[\left(\frac{kg}{.001} \right) \cdot \left(\frac{24\ hr}{1\ day} \right) \right] = Flow\ in\ \frac{t}{hr} \cdot 24000$$

$$Conversion\ Factor = 24000$$

This factor is then entered as the Conversion Factor value in Flow Compensation Wizard of the SCT during configuration. Please note that when using the standard equation, the conversion factor, as well as other values, are used to calculate the Wizard Kuser factor. When using the dynamic corrections equation, the conversion factor is used as the Kuser factor.

Refer to the SCT on-line manual for additional information about using custom units in your SMV 3000 configuration.

6.11 Flow Compensation Wizard

Description

A Flow Compensation Wizard is provided with the SCT 3000 which is used to configure PV4, the flow variable of the SMV 3000 Multivariable Transmitter. The flow compensation wizard will guide you in configuring the PV4 output for either a standard flow equation or a dynamic compensation flow equation.

- You can access the flow compensation wizard by pressing the  button in the SCT /SMV 3000 configuration window.
- Refer to the SCT 3000 on-line User Manual for detailed information for using the flow compensation wizard.

Standard Equation

The SMV 3000 standard flow equation is a simplified version of the ASME MFC-3M flow equation. The SMV 3000 uses the standard equation to compensate for the density changes in gases, liquids and steam (saturated and superheated) and can be used with any primary flow element that behaves according to the following equation:

$$Flow = K_{irr} \cdot \sqrt{\Delta P}$$

See Appendix C for the SMV 3000 standard flow equations and examples of flow configuration using the flow compensation wizard.

Dynamic Compensation Equation

The SMV 3000 dynamic compensation flow equation is the ASME flow equation as described in ASME MFC-3M, “*Measurement of Fluid Flow in Pipes Using Orifice, Nozzle and Venturi.*” The dynamic compensation flow equation should be used to increase the flow measurement accuracy and flow turndown for the primary elements listed in Table 18.

Table 18 Primary Flow Elements

	Primary Element	Application
Orifice	- Flange taps (ASME - ISO) $D \geq 2.3$	Gases, liquids and steam
	- Flange taps (ASME - ISO) $2 \leq D \leq 2.3$	Gases, liquids and steam
	- Corner taps (ASME - ISO)	Gases, liquids and steam
	- D and D/2 taps (ASME - ISO)	Gases, liquids and steam
	- 2.5D and 8D taps (ASME - ISO)	Liquids

Continued on next page

6.11 Flow Compensation Wizard, Continued

Dynamic Compensation Equation, continued

Table 18 Primary Flow Elements, Continued

Primary Element	Application	
Venturi	- Machined Inlet (ASME - ISO)	Liquids
	- Rough Cast Inlet (ASME - ISO)	Liquids
	- Rough Welded sheet-iron inlet (ASME - ISO)	Liquids
Ellipse® Averaging Pitot Tube	Gases, liquids and steam	
Nozzle (ASME Long Radius)	Liquids	
Venturi Nozzle (ISA inlet)	Liquids	
ISA Nozzle	Liquids	
Leopold Venturi	Liquids	
Gerand Venturi	Liquids	
Universal Venturi Tube	Liquids	
Lo-Loss Tube	Liquids	

Dynamic Compensation Equation

The dynamic compensation flow equation for mass applications is:

$$Flow = N_{M\rho} \cdot C \cdot Y_1 \cdot E_V \cdot d^2 \cdot \sqrt{\rho_f \cdot h_w}$$

which provides compensation dynamically for discharge coefficient, gas expansion factor, thermal expansion factor, density, and viscosity.

6.12 Saving, Downloading and Printing a Configuration File

Saving, Downloading and Printing a Configuration File

Once you have entered the SMV parameter values into the SCT tab cards, you save the database configuration file. If you are configuring the SMV on-line, you can save and then download the configuration values to the transmitter.

Be sure to save a backup copy of the database configuration file on a diskette.

You can also print out a summary of the transmitter's configuration file. The printable document contains a list of the individual parameters and the associated values for each transmitter's database configuration.

Follow the specific instructions in the SCT 3000 help to perform these tasks.

6.13 Verifying Flow Configuration

Verify Flow Configuration

To verify the SMV transmitter's PV4 calculated flow output for your application, you can use the SMV to simulate PV input values to the transmitter and read the PV4 output. The output can be compared with expected results and then adjustments can be made to the configuration if necessary.

See Section 7.4, *Using Transmitter to Simulate PV Input* for the procedure.

Section 7 —Startup

7.1 Introduction

Section Contents

This section includes these topics

Topic	See Page
7.1 Introduction	79
7.2 Startup Tasks	80
7.3 Running Output Check	81
7.4 Using Transmitter to Simulate PV Input.....	84
7.5 Starting Up Transmitter	86

About this section

This section identifies typical startup tasks associated with a generic flow measurement application. It also includes the procedure for running an optional output check for SMV transmitters operating in analog or digital (DE) modes.

7.2 Startup Tasks

About Startup

Once you have installed and configured a transmitter, you are ready to start up the process loop. Startup usually includes

- Simulate pressure and temperature inputs to the transmitter,
- Reading inputs and outputs
- Checking zero input

You can also run an optional output check to “wring out” an analog loop and check out individual PV outputs (in DE mode) prior to startup.

Step Procedures

The actual steps in the startup procedure will vary based on the transmitter type, the piping arrangement and the measurement application. In general, we use the SCT to check the transmitter’s input and output under static process conditions, simulate input signals and make adjustments as required before putting the transmitter into full operation with the running process.

BAD PV displayed on TPS/TDC systems

For SMV transmitters that are digitally integrated with Honeywell’s TPS/TDC systems, note that simulated PV readings on Universal Station displays will be flagged as BAD PV although the “PVRAW” reading will continue to be displayed will reflect the simulated input.

7.3 Running Output Check

Background

An SMV transmitter operating in the **analog mode** can be put into a constant-current source mode (called the output mode) to checkout other instruments in the control loop such as recorders, controllers, and positioners. Using the SCT, you can tell the transmitter to change its output to any value between 0 percent (4mA or 1V) and 100 percent (20mA or 5V) and maintain that output. This makes it easy to verify loop operation through the accurate simulation of transmitter output signals before bringing the loop on-line.

For SMV transmitters operating the **DE mode**, you can simulate an output for each PV individually to verify output at the digital receiver or DCS. Follow the steps in Table 20 for transmitters in DE mode.

ATTENTION

The transmitter does not measure the given PV input or update the PV output while it is in the output mode.

Analog Output Mode Procedure

IMPORTANT: Before performing this procedure, you must check the calibration of the transmitter's D/A converter. Perform the procedure "*The Steps to Calibrate for PV4 Output,*" found in the Calibration section of the SCT on-line user manual.

The procedure in Table 19 outlines the steps for checking the PV output for SMV transmitter operating in analog mode.

Table 19 Analog Output Check Procedure

Step	Action
1	Connect SCT to SMV and establish communications. (See Subsection 5.2 for procedure, if necessary.)
2	Be sure any switches that may trip alarms or interlocks associated with analog loops are secured or turned off.
3	Perform Upload of the SMV database to the SCT.
4	Select <i>General</i> tab card and set communication mode to Analog.

Continued on next page

7.3 Running Output Check, Continued

Procedure, continued

Table 19 Analog Output Check Procedure, continued

Step	Action
5	We assume that most analog transmitters will have PV4 as the selected output. This also means that receiver instrument will be configured to match PV4 output range. If you have selected the analog output to represent another PV, be sure it is the appropriate PV number used to check output.
6	Open the <i>PV Monitor</i> window by selecting PV Monitor from the View pull down menu. Read the PV4 output.
7	Select <i>FlowOutCal</i> tab card and set output at 30% and place PV4 in output mode.
8	Open <i>PV Monitor</i> window and read the PV4 in desired engineering units that is equivalent to 30% output.
9	Verify 30% output on all receiver devices.
10	Select <i>FlowOutCal</i> tab card and clear the output mode of PV4.
11	Select <i>Status</i> tab card to verify that all transmitter outputs are in not in output mode and that there are no new messages.
12	You can repeat steps 6 through 10 to simulate other PV outputs, (such as PV1, PV2, or PV3).

Output Check Procedure for SMV Transmitters in DE mode

ATTENTION

The procedure in Table 20 outlines the steps for checking the PV outputs for SMV transmitter in DE mode.

The transmitter does not measure the given PV input or update the PV output while it is in the output mode.

For SMV transmitters that are digitally integrated with Honeywell's TPS/TDC systems, note that PV readings on Universal Station displays will be flagged as BAD PV although the "PVRAW" reading will continue to be displayed will reflect the simulated input.

Continued on next page

7.3 Running Output Check, Continued

Procedure

Table 20 Output Check for SMV Transmitters in DE Mode

Step	Action
1	Connect SCT to SMV and establish communications. (See Subsection 5.2 for procedure, if necessary.)
2	Be sure any switches that may trip alarms or interlocks associated with analog loops are secured or turned off.
3	Perform Upload of the SMV database to the SCT.
4	Select <i>General</i> tab card and set communication mode to Digital Enhanced.
5	Set any of the SMV transmitter PVs to output mode, by selecting the appropriate tab cards. <ul style="list-style-type: none"> • <i>DPOutCal</i>, (for PV1) • <i>APOutCal</i>, (for PV2) • <i>TempOutCal</i>, (for PV3) or • <i>FlowOutCal</i>, (for PV4)
6	Enter an output value and then set PV to Output mode.
7	Open the <i>PV Monitor</i> window by selecting PV Monitor from the View pull down menu. Read the PV outputs. Also, check the PV outputs as displayed at the digital receiver.
8	Select appropriate tab card for the PVs that were set to output mode and clear the output mode.
9	Select <i>Status</i> tab card to verify that all transmitter outputs are in not in output mode and that there are no new messages.

7.4 Using Transmitter to Simulate PV Input

Using SMV Transmitter in Input Mode

You can use an SMV 3000 transmitter to simulate a PV input value through the transmitter's input mode. This feature is useful to check a PV's affect on the transmitter's output and compare expected readings on other analog instruments in the loop such as recorders, controllers, and positioners. For SMV transmitters operating in DE mode, inputs can be simulated for each PV to check the transmitter's outputs on Universal Station displays with our TPS/TDC systems.

Using the SCT, you can tell the transmitter to change a PV input to any acceptable range value and maintain that input. This makes it easy to check PV input operation through the accurate simulation of input signals. This is especially helpful in verifying the affect of a given input on the PV4 calculated flow rate output.

NOTE: The input mode overrides the output mode.

CAUTION

When the transmitter is in the input mode:

- The simulated PV input value is substituted for the measured input
- The output reflects the simulated input.

ATTENTION

For SMV transmitters that are digitally integrated with Honeywell's TPS/TDC systems, note that PV readings on Universal Station displays will be flagged as BAD PV although the "PVRAW" reading will continue to be displayed will reflect the simulated input.

Input Mode Procedure The procedure in Table 21 outlines the steps for using the transmitter in its input mode and clearing the input mode.

Table 21 Using SMV Transmitter in the Input Mode

Step	Action
1	Connect SCT to SMV and establish communications. (See Subsection 5.2 for procedure, if necessary.)
2	Be sure any switches that may trip alarms or interlocks associated with analog loops are secured or turned off.
3	Perform Upload of the SMV database to the SCT.
4	For example purposes we want to simulate the PV1 input while monitoring PV4 output.

Continued on next page

7.4 Using Transmitter to Simulate PV Input, Continued

Procedure, continued

Table 21 Using SMV Transmitter in the Input Mode, Continued

Step	Action
5	Select <i>DPIInCal</i> tab card and type in desired PV1 input value that is to be simulated. Value should be within LRV and URV settings for PV1.
6	Write input to simulate input for PV1.
7	Repeat Steps 5 and 6 if you want to simultaneously simulate another PV input, by selecting the appropriate tab cards. <ul style="list-style-type: none"> • <i>APIInCal</i>, (for PV2) • <i>TempInCal</i>, (for PV3) or • <i>FlowInCal</i>, (for PV4)
8	Select PV Monitor from the View pull down menu to open the <i>PV Monitor</i> window and read PV4 FLOW output and verify PV input. Record the output value and compare it with expected results. See NOTE below. If output is not as expected, check range and PV4 configuration data, and change as required.
9	Clear input mode for all PVs in input mode.
10	Select <i>Status</i> tab card to verify that all transmitter inputs are in not in input mode and that there are no new messages.

NOTE: For SMV models SMG170, (which uses gauge pressure as PV2 input), you must measure the absolute static pressure and then enter that value in the Atmospheric Offset field of the *GPCConf* tab card.

Internally, the SMV transmitter uses absolute pressure values for all flow calculations. The value entered in the Atmospheric Offset field is added to the gauge pressure input value to approximate the absolute pressure. An inaccurate atmospheric pressure offset value will result in a small error of the flow calculation.

Use an absolute pressure gauge to measure the correct atmospheric pressure. A standard barometer may not give an accurate absolute pressure reading

7.5 Starting Up Transmitter

Procedure

NOTE: Perform the procedure in Section 7.4, *Using the Transmitter to Simulate PV Input*, before performing these start-up procedures.

The following procedures outline the steps for starting up SMV 3000 transmitters in flow measurement applications. Refer to the appropriate start-up procedure for SMV transmitter used in your process application.

- Table 22 for SMV 3000 Model SMA125 (PV2 measures AP)
- Table 23 for SMV 3000 Model SMG170 (PV2 measure GP)
- Table 24 for SMV 3000 Model SMA110 (PV2 measures AP) (draft range transmitter) and SMV transmitters with small differential pressure spans.

Refer to Figure 26 for the piping arrangement and equipment used for the procedure. Typical meter and SCT (or SFC) connections are also shown in the figure.

SMV Model SMA125 Start-up Procedure

Table 22 Start up Procedure for SMV Transmitter Model SMA125

Step	Action
1	Make sure that all valves on the three-valve manifold are closed. See Figure 26 for sample piping arrangement.
2	For analog loops, make sure the receiver instrument in the loop is configured for the PV4 output range.
3	Connect SCT to SMV and establish communications. (See subsection 5.2 for procedure, if necessary.)
4	Be sure any switches that may trip alarms or interlocks associated with analog loops are secured or turned off.
5	Perform Upload of the SMV database to the SCT.
6	Open equalizer valve C.
7	Open valve A to make differential pressure zero (0) by applying same pressure to both sides of meter body. Allow system to stabilize at full static pressure - zero differential.
8	Select <i>DPInCal</i> tab card and read input of applied DP (PV1) pressure in the selected engineering unit. <ul style="list-style-type: none"> • If input reads 0% input, go to step 9. • If input does not read 0% input, <ul style="list-style-type: none"> - Click the Input option button. - Click the Correct button to correct input to zero.

Continued on next page

7.5 Starting Up Transmitter, Continued

Procedure, continued

Table 22 Start up Procedure for SMV Transmitter Model SMA125, continued

Step	Action
9	Select <i>APInCal</i> tab card and read input of applied AP (PV2) pressure in the selected engineering unit. Verify that it is equivalent to absolute pressure at zero point.
10	Select <i>TempInCal</i> tab card and read input of applied temp (PV3) input in desired engineering unit. Verify that it is equivalent to process temperature.
11	Close equalizer valve C and open valve B.
12	Select the <i>FlowInCal</i> tab card and read input Flow (PV4) signal in desired engineering unit. Verify that it is equivalent to calculated flow rate at operating conditions.

**SMV Model SMA125
Start-up Procedure**

Use the procedure in Table 23 to start-up an SMV 3000 transmitter model SMG170, which measures gauge pressure as the PV2 input.

Table 23 Start up Procedure for SMV Transmitter Model SMG170

Step	Action
1	Make sure that all valves on the three-valve manifold are closed. See Figure 26 for sample piping arrangement.
2	For analog loops, make sure the receiver instrument in the loop is configured for the PV4 output range.
3	Connect SCT to SMV and establish communications. (See subsection 5.2 for procedure, if necessary.)
4	Be sure any switches that may trip alarms or interlocks associated with analog loops are secured or turned off.
5	Perform Upload of the SMV database to the SCT.
6	Vent high pressure and low pressure input ports to atmosphere. Steam applications with filled wet legs should be filled and vented to atmosphere.
7	Select <i>GPInCal</i> tab card and read input of applied GP (PV2) pressure. <ul style="list-style-type: none"> • If input reads 0% input, go to step 8. • If input does not read 0% input, <ul style="list-style-type: none"> - Select Input option - Click on Correct. - Read Input. Input will now read GP pressure at zero point.

Continued on next page

7.5 Starting Up Transmitter, Continued

Procedure, continued

Table 23 Start up Procedure for SMV Transmitter Model SMG170, continued

Step	Action
8	Close vents to high pressure and low pressure input ports. Close vents to wet legs in steam applications.
9	Open equalizer valve C.
10	Open valve A to make differential pressure zero (0) by applying same pressure to both sides of meter body. Allow system to stabilize at full static pressure - zero differential.
11	Select <i>DPInCal</i> tab card and read input of applied DP (PV1) pressure in the selected engineering unit. <ul style="list-style-type: none"> • If input reads 0% input, go to step 12. • If input does not read 0% input, <ul style="list-style-type: none"> - Click the Input option button. - Click the Correct button to correct input to zero.
12	Select <i>TempInCal</i> tab card and read input of applied temperature (PV3) input in desired engineering unit. Verify that it is equivalent to process temperature.
13	Close equalizer valve C and open valve B.
14	In the <i>FlowInCal</i> tab card and read input Flow (PV4) signal in desired engineering unit. Verify that it is equivalent to calculated flow rate at operating conditions.

**SMV Draft Range
Start-up Procedure**

Use the procedure in Table 24 to start-up an SMV 3000 transmitter model SMA110 and transmitters with small differential pressure spans.

Table 24 Start up Procedure for SMV Transmitter Model SMA110

Step	Action
1	Make sure that all valves on the three-valve manifold are closed. See Figure 26 for sample piping arrangement. For installations without a three-valve manifold, connect a tube between the high pressure (HP) and low pressure (LP) input ports.
2	Make sure the transmitter is attached to the mounting brackets but the bolts are not tightened completely; loosen if necessary.

Continued on next page

7.5 Starting Up Transmitter, Continued

Procedure, continued

Table 24 Start up Procedure for SMV Transmitter Model SMA110, continued

Step	Action
3	For analog loops, make sure the receiver instrument in the loop is configured for the PV4 output range.
4	Connect SCT to SMV and establish communications. (See subsection 5.2 for procedure, if necessary.)
5	Be sure any switches that may trip alarms or interlocks associated with analog loops are secured or turned off.
6	Perform Upload of the SMV database to the SCT.
7	Open valve A and equalizer valve C in the three-valve manifold. Allow system to stabilize at full static pressure - zero differential.
8	Select <i>DPInCal</i> tab card and read input of applied DP (PV1) pressure in the selected engineering unit.
9	While monitoring the transmitter's PV1 input, position the transmitter so that the transmitter input is reading at or near zero and then tighten the mounting bolts completely. Note that you must click on Read Input in order to obtain updated input pressure <ul style="list-style-type: none"> • When input reads 0% input, go to step 10. • If input does not read 0% input, <ul style="list-style-type: none"> - Click the Input option button. - Click the Correct button to correct input to zero.
10	Close equalizer valve C and open valve B, or remove the tubing from between the input ports and restore transmitter piping.
11	Select <i>APInCal</i> tab card and read input of applied AP (PV2) pressure in the selected engineering unit. Verify that it is equivalent to absolute pressure at zero point.
12	Select <i>TempInCal</i> tab card and read input of applied temperature (PV3) input in desired engineering unit. Verify that it is equivalent to process temperature.
13	Close equalizer valve C and open valve B.
14	In the <i>FlowInCal</i> tab card and read input Flow (PV4) signal in desired engineering unit. Verify that it is equivalent to calculated flow rate at operating conditions.

Continued on next page

7.5 Starting Up Transmitter, Continued

Figure 26 Typical SCT or SFC and Meter Connections for SMV Start up Procedure.

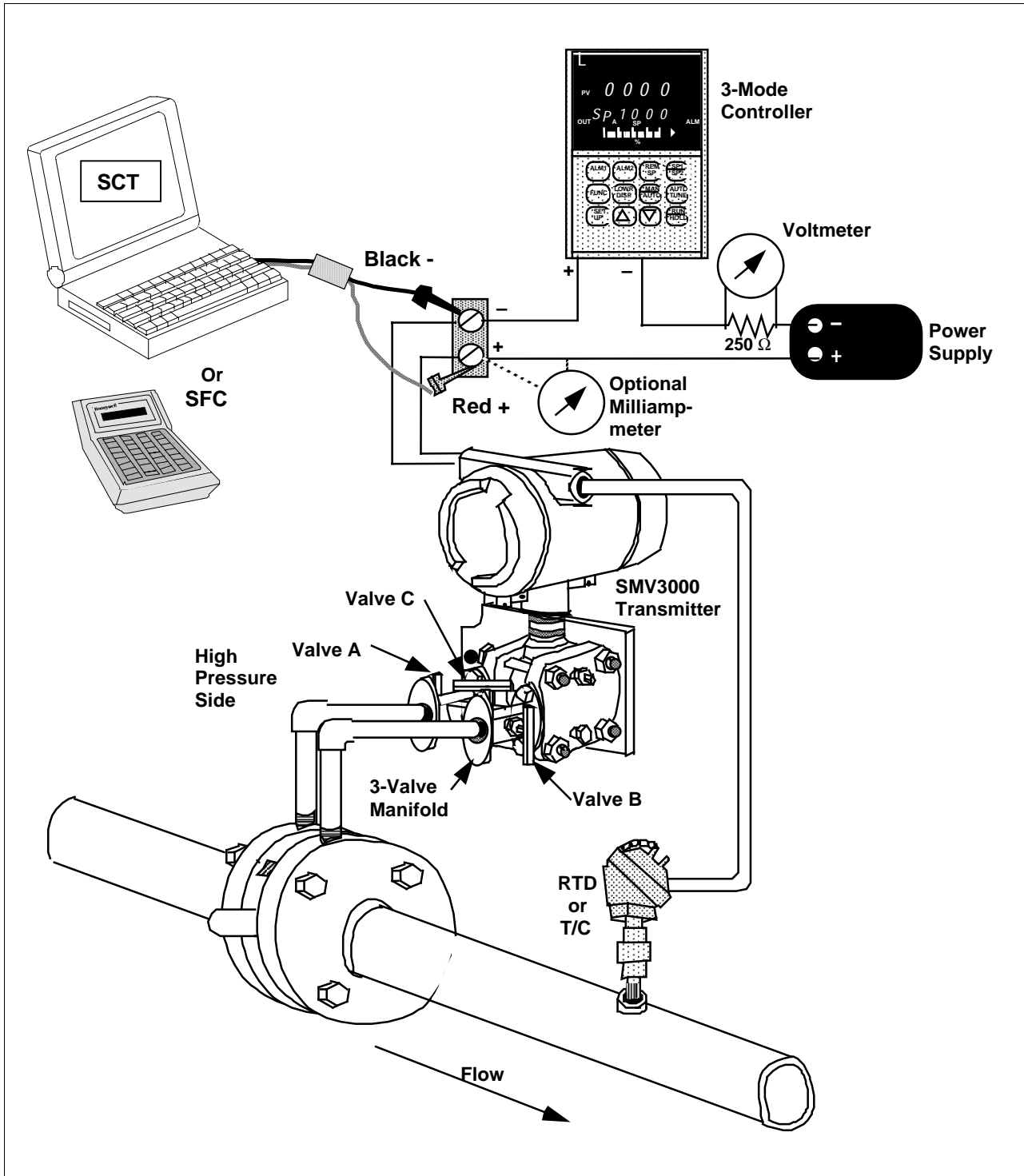

Section 8 —Operation

8.1 Introduction

Section Contents

This section includes these topics

Topic	See Page
8.1 Introduction	91
8.2 Accessing Operation Data.....	92
8.3 Changing Default Failsafe Direction	95
8.4 Saving and Restoring a Database.....	98

About this section

This section identifies how to access typical data associated with the operation of an SMV 3000 transmitter. It also includes procedures for

- Changing the default failsafe direction,
 - Writing data in the scratch pad area, and
 - Saving and Restoring a database.
-

8.2 Accessing Operation Data

Summary

You can access this data relevant to the operation of the transmitter using the SCT.

- Current PV number selection
- Input
- Output
- Span
- Upper Range Limit
- Failsafe output direction
- Status
- Sensor (meter body) temperature
- Cold Junction Temperature
- High/low PV
- Lower Range Limit
- PROM serial number
- Scratch pad messages

Procedure

Table 25 summarizes how to access the given operation data from the transmitter using the SCT. The procedures assume that the SCT has been connected and communications have been established with the transmitter by selecting Tag ID menu item.

Table 25 Accessing Transmitter Operation Data Using SCT

IF you want to view...	Select the SCT Window or Tab Card	And . . .
the present PV number selected for display, (transmitter in analog mode).	<i>General</i> Tab Card	Read: Analog Output Selection
the status of transmitter operation at the present time.	<i>Status</i> Tab Card	Read: Gross Status Detailed Status
the PROM serial number. the Firmware Version of the transmitter. the present message in the scratch pad area of memory.	<i>Device</i> Tab Card	Read: Serial Number Firmware Version Scratch Pad

Continued on next page

8.2 Accessing Operation Data, Continued

Procedure, continued

Table 25 Accessing Transmitter Operation Data Using SCT, Continued

IF you want to view...	Select the SCT Window or Tab Card	And . . .
<ol style="list-style-type: none"> the input value for a given PV, which is updated every six seconds. the present transmitter output in percent for a given PV, which is updated every six seconds. 	<i>PV Monitor</i> Window	Read: PV Input PV % of span
<ol style="list-style-type: none"> the span, which is the URV minus the LRV for a given PV. the Upper Range Limit of a given PV. the Lower Range Limit of a given PV. 	<i>DPCConf</i> (for PV1) <i>APCConf</i> (for PV2) <i>TempConf</i> (for PV3) <i>FlowConf</i> (for PV4)	Read: Span URL LRL
the failsafe output direction for the transmitter. <div style="border: 1px solid black; padding: 2px; display: inline-block;">ATTENTION</div> You can change the default failsafe direction from upscale to downscale. See Section 8.3, "Changing Default Failsafe Direction".	<i>General</i> Tab Card	Read: Analog Failsafe Direction
the present meter body temperature (± 5 °C) measured by circuitry in the transmitter's sensor. <div style="border: 1px solid black; padding: 2px; display: inline-block;">ATTENTION</div> You can change the temperature engineering units to °F, °R or °K by selecting the SV Units field in the <i>DPCConf</i> tab card.	<i>PV Monitor</i> Window	Click on SV button on DP gauge Read: SV

Continued on next page

8.2 Accessing Operation Data, Continued

Procedure, continued

Table 25 Accessing Transmitter Operation Data Using SCT, Continued

IF you want to view...	Select the SCT Window or Tab Card	And . . .
<p>the cold junction temperature.</p> <p>ATTENTION You can change the temperature engineering units to °F, °R or °K by selecting the CJT Units field in the <i>TempConf</i> tab card.</p>	<p><i>PV Monitor</i> Window</p>	<p>Click on SV button on Temp gauge</p> <p>Read: SV</p>
<p>the highest and lowest PV3 values since the last time they were displayed.</p> <p>ATTENTION You can change the temperature engineering units to °F, °R or K by selecting the Engineering Units field in the <i>TempConf</i> tab card.</p>	<p><i>TempConf</i></p>	<p>Click on Read H/L button.</p> <p>Read: High/Low PV</p> <p>High</p> <p>Low</p>

8.3 Changing Default Failsafe Direction

Background

Transmitters are shipped with a default failsafe direction of upscale. This means that the transmitter's output will be driven upscale (maximum output) when the transmitter detects a critical status.

You can change the direction from upscale to downscale (minimum output) by cutting jumper W1 on the main printed circuit board (PWA) of the electronics module.

Analog and DE Mode Differences

If your transmitter is operating in the analog mode, an upscale failsafe action will drive the transmitter's output to 21.8 mA or a downscale action will drive its output to 3.8 mA.

If your transmitter is operating in the DE mode, an upscale failsafe action will cause the transmitter to generate a "+ infinity" digital signal, or a downscale failsafe action will cause it to generate a "- infinity" digital signal. The STIMV IOP module interprets either signal as "not a number" and initiates its own configured failsafe action for the control system.

ATTENTION

The failsafe direction display that you can access through the SCT only shows the state of the failsafe jumper in the transmitter as it correlates to analog transmitter operation. The failsafe action of the digital control system may be configured to operate differently than indicated by the state of the jumper in the transmitter.

Procedure

The procedure in Table 26 outlines the steps for cutting the failsafe jumper on the transmitter's PWA. Figure 27 shows the location of the failsafe jumper on the main PWA of the electronics module.



The nature of the integrated circuitry used in the transmitter's PWA makes it susceptible to damage by stray static discharges when it is removed from the transmitter. Follow these tips to minimize chances of static electricity damage when handling the PWA.

- Never touch terminals, connectors, component leads, or circuits when handling the PWA.
 - When removing or installing the PWA, hold it by its edges or bracket section only. If you must touch the PWA circuits, be sure you are grounded by staying in contact with a grounded surface or wearing a grounded wrist strap.
 - As soon as the PWA is removed from the transmitter, put it in an electrically conductive bag or wrap it in aluminum foil to protect it.
-

Continued on next page

8.3 Changing Default Failsafe Direction, Continued

Procedure, continued

Table 26 Cutting Failsafe Jumper

Step	Action
1	Connect SCT to SMV and establish communications. (See subsection 5.2 for procedure, if necessary.)
2	Be sure any switches that may trip alarms or interlocks associated with analog loops are secured or turned off.
3	Open the <i>Status</i> Tab Card. Read and record the gross and detailed status messages of the transmitter.
4	Turn OFF transmitter power. Loosen end-cap lock and unscrew end cap from electronics side of transmitter housing.
5	Release retaining clip and unplug flex tape and power connectors from Main PWA underneath module. Unplug temperature input connector from Daughter PWA underneath module. Loosen two captive mounting screws on top of module, and then carefully pull module from housing.
6	<p>ATTENTION You may be able to cut the failsafe jumper without removing the molding and Daughter PWA as noted in this Step and the next one. Just be sure you can identify the jumper and don't damage other components in the process of cutting it.</p> <p>Remove screw holding connector molding/retaining clip to Main PWA and remove molding.</p>
7	Remove two retaining screws and carefully pull Daughter PWA straight up to unplug it from connector on Main PWA.
8	With component side of PWA facing you, locate failsafe jumper and cut it in half with small wire cutter such as dykes. See Figure 27. This changes failsafe action from upscale to downscale.
9	Reverse applicable previous steps to replace PWA/module.

Continued on next page

8.3 Changing Default Failsafe Direction, Continued

Procedure, continued

Table 26 Cutting Failsafe Jumper, Continued

Step	Action
10	Turn ON transmitter power.
11	Perform Upload of the SMV database to the SCT.
12	Open the <i>Status</i> Tab Card. Read the gross and detailed status messages of the transmitter. Verify that the status messages are the same as recorded in Step 3.

Figure 27 Location of Failsafe Jumper on main PWA of Electronics Module.

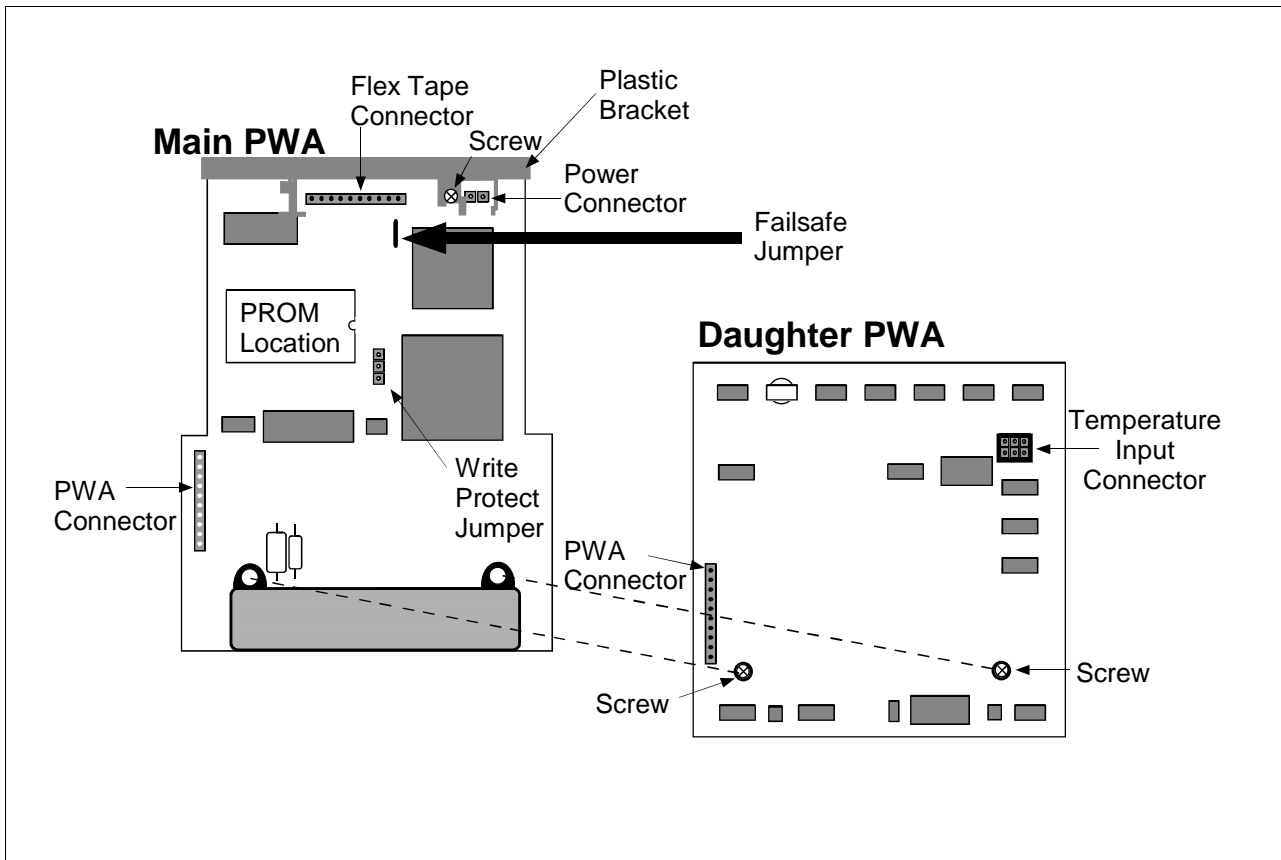

8.4 Saving and Restoring a Database

Saving and Restoring a SMV Configuration Database

It is recommended that you keep a disk file of the current the configuration databases for all smart field devices, just in case of a device failure and/or replacement.

If it becomes necessary to replace a damaged transmitter with a spare, you can restore the saved configuration database disk file in the spare transmitter. In fact, you can restore the saved configuration database in any number of transmitters as long as you change the tag number (Tag ID) in the restored database.

Section 9 —Maintenance

9.1 Introduction

Section Contents

This section includes these topics

Topic	See Page
9.1 Introduction	99
9.2 Preventive Maintenance	100
9.3 Inspecting and Cleaning Barrier Diaphragms	101
9.4 Replacing Electronics Module or PROM.....	103
9.5 Replacing Meter Body Center Section.....	108

About this section

This section provides information about preventive maintenance routines, cleaning barrier diaphragms, and replacing damaged parts.

9.2 Preventive Maintenance

Maintenance Routines And Schedules

The SMV 3000 transmitter itself does not require any specific maintenance routine at regularly scheduled intervals. However, you should consider carrying out these typical inspection and maintenance routines on a schedule that is dictated by the characteristics of the process medium being measured and whether blow-down facilities are being used.

- Check piping for leaks
 - Clear the piping for sediment or other foreign matter
 - Clean the transmitter's process heads including the barrier diaphragms
-

9.3 Inspecting and Cleaning Barrier Diaphragms

Background

Depending on the characteristics of the process medium being measured, sediment or other foreign particles may collect in the process head cavity/chamber and cause faulty measurement. In addition, the barrier diaphragms in the transmitter's meter body may become coated with a residue from the process medium.

In most cases, you can readily remove the process heads from the transmitter's meter body to clean the process head cavity and inspect the barrier diaphragms.

Procedure

The procedure in Table 27 outlines the general steps for inspecting and cleaning barrier diaphragms.

Table 27 Inspecting and Cleaning Barrier Diaphragms

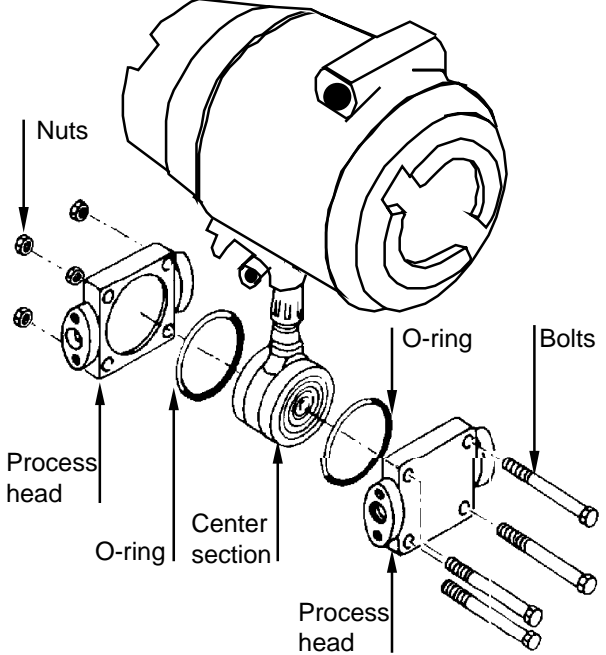
Step	Action
1	Close all valves and isolate transmitter from process. Open vent in process head to drain fluid from transmitter's meter body, if required. ATTENTION We recommend that you remove the transmitter from service and move it to a clean area before taking it apart.
2	Remove nuts from bolts that hold process heads to meter body. Remove process heads and bolts. 

Continued on next page

9.3 Inspecting and Cleaning Barrier Diaphragms, Continued

Procedure, continued

Table 27 Inspecting and Cleaning Barrier Diaphragms, Continued

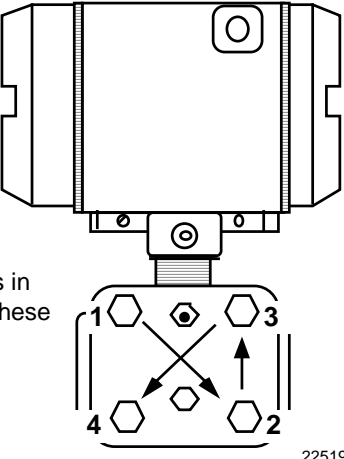
Step	Action
3	Remove O-ring and clean interior of process head using soft bristle brush and suitable solvent.
4	Inspect barrier diaphragm for any signs of deterioration or corrosion. Look for possible residue and clean if necessary. NOTE: If diaphragm is dented, has distorted convolutions or radial wrinkles, performance may be affected. Contact the Solutions Support Center for assistance.
5	Replace O-ring or teflon gasket ring.
6	Coat threads on process head bolts with anti-seize compound such as "Neverseize" or equivalent.
7	Replace process heads and bolts. Finger tighten nuts.
8	Use a torque wrench to gradually tighten nuts to torque of 40 ft-lb (54 N•m) for carbon steel process head bolts or 35 ft-lb (47.5 N•m) for stainless steel process head bolts in sequence shown in following illustration. Tighten head bolts in stages of 1/3 full torque, 2/3 full torque, and then full torque. <div style="text-align: center; margin-top: 20px;">  <p data-bbox="738 1480 1063 1564">Always tighten head bolts in sequence shown and in these stages:</p> <ol data-bbox="787 1575 966 1659" style="list-style-type: none"> 1. 1/3 full torque 2. 2/3 full torque 3. Full torque <p data-bbox="1307 1654 1364 1675">22519</p> </div>
9	Return transmitter to service. <div style="border: 1px solid black; padding: 2px; display: inline-block; margin-bottom: 5px;">CAUTION</div> Do not exceed the overload rating when placing the transmitter back into service or during cleaning operations. See Overpressure ratings in Section 3 of this manual.

9.4 Replacing Electronics Module or PROM

Module description The electronics module used in the SMV 3000 transmitter is a two Printed Wiring Assembly design that includes an integral mounting bracket, we refer to the PWAs as Main PWA and Temperature or Daughter PWA as a way to distinguish them.

PROM identification The plug-in PROM on the main PWA is uniquely characterized to the meter body of the given transmitter. For this reason, each PROM is given a 10-digit identification number so you can verify that a replacement PROM is the correct match for the given transmitter. The PROM identification number is stamped on the nameplate on the transmitter's meter body and appears on a label under the PROM. You can also read the PROM number using the SCT – See Section 8.2 in this manual for details.

Procedure The procedure in Table 28 outlines the steps for replacing the electronics module or the plug-in PROM. Since you must remove the electronics module and PROM in either case, you can easily adapt the steps as required.

Table 28 Replacing Electronics Module or PROM

Step	Action
1	Turn OFF transmitter power. ATTENTION We recommend that you remove the transmitter from service and move it to a clean area before taking it apart.
2	Loosen end cap lock and unscrew end cap from electronics side of housing.

Continued on next page

9.4 Replacing Electronics Module or PROM, Continued

Procedure, continued

Table 28 Replacing Electronics Module or PROM, Continued

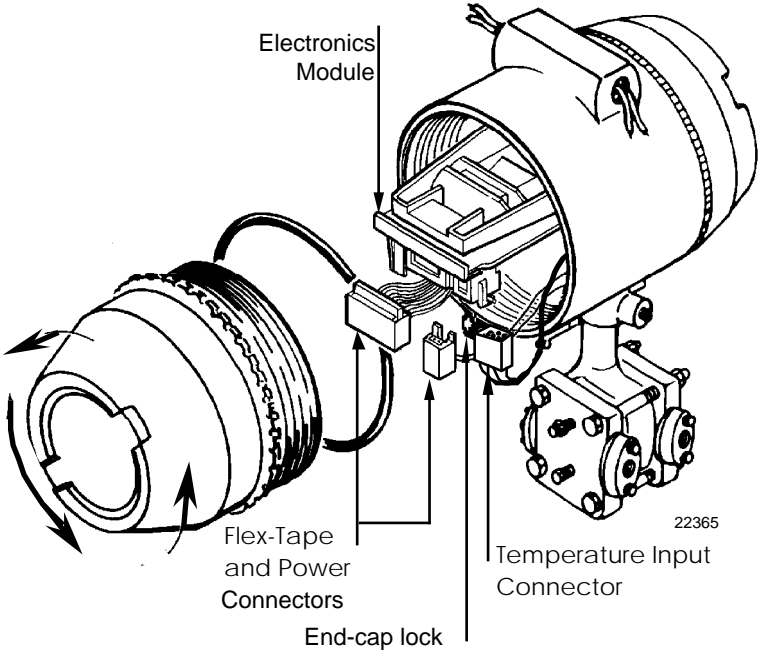

Step	Action
3	<p>Release retaining clip and unplug flex -tape and power connectors from Main PWA underneath module. Unplug temperature input connector from RTD measurement (Daughter) PWA underneath module. Loosen two captive mounting screws on top of module, and then carefully pull module from housing.</p>  <p>The diagram illustrates the disassembly process. It shows a cutaway view of the transmitter housing with the Electronics Module being pulled out. Labels include: 'Electronics Module' pointing to the module being removed; 'Flex-Tape and Power Connectors' pointing to the connectors on the back of the module; 'End-cap lock' pointing to a small component on the back of the module; and 'Temperature Input Connector' pointing to a connector on the daughter PWA. A part number '22365' is shown near the daughter PWA. Arrows indicate the direction of removal for the module and the end-cap lock.</p>
4	<p>Remove screw holding molding/retaining clip to Main PWA and remove molding/retaining clip from Main PWA.</p>

Continued on next page

9.4 Replacing Electronics Module or PROM, Continued

Procedure, continued

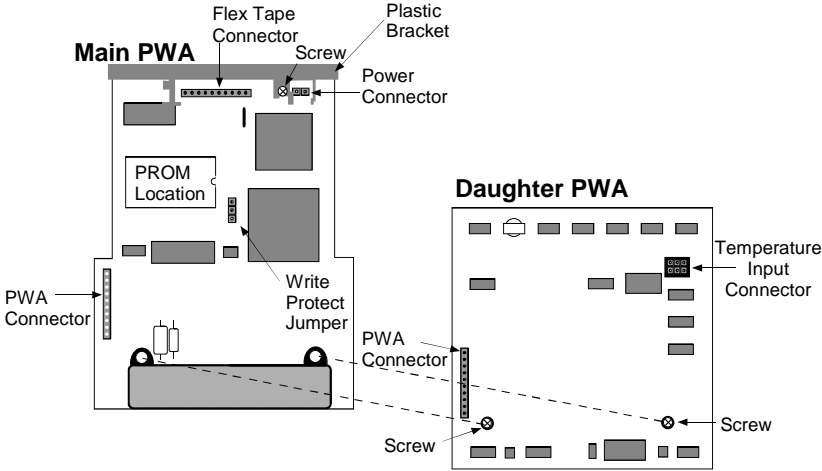
Table 28 Replacing Electronics Module or PROM, Continued

Step	Action						
5	<p>Remove two retaining screws and carefully pull Daughter PWA straight up to unplug it from Main PWA.</p> 						
6	<p>With component side of main PWA facing you, use an IC extraction tool to remove plug-in PROM.</p>  <p>We recommend that you use a ground strap or ionizer when handling the plug-in PROM, since electrostatic discharges can cause PROM failures.</p>						
7	<table border="1" data-bbox="686 1461 1414 1566"> <thead> <tr> <th>If you are replacing the...</th> <th>Then...</th> </tr> </thead> <tbody> <tr> <td>Electronics module</td> <td>go to Step 8</td> </tr> <tr> <td>PROM</td> <td>go to Step 9</td> </tr> </tbody> </table>	If you are replacing the...	Then...	Electronics module	go to Step 8	PROM	go to Step 9
If you are replacing the...	Then...						
Electronics module	go to Step 8						
PROM	go to Step 9						

Continued on next page

9.4 Replacing Electronics Module or PROM, Continued

Procedure, continued

Table 28 Replacing Electronics Module or PROM, Continued

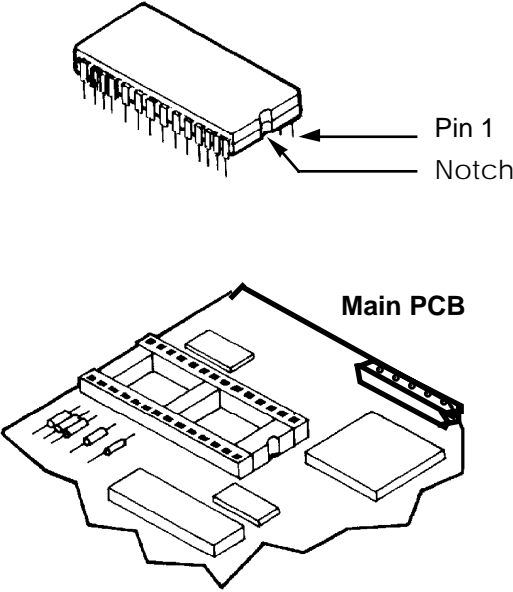
Step	Action
<p>8</p>	<p>With component side of new PWA facing you, align notch and pin 1 of PROM removed in Step 6 with notch and pin 1 in IC socket on new PWA. Carefully plug PROM into socket. Go to Step 11.</p>  <p>ATTENTION If the new electronics module has the write protect option, be sure to check that the write protect jumper is in the desired position. See the Write protect option in Section 5.4 of this manual for details.</p>
<p>9</p>	<p>Verify that 10-digit identification number on label under new PROM matches PROM ID number stamped on meter body nameplate. If PROM numbers don't match, you must order a new PROM specifying PROM number from meter body nameplate.</p>

Continued on next page

9.4 Replacing Electronics Module or PROM, Continued

Procedure, continued

Table 28 Replacing Electronics Module or PROM, Continued

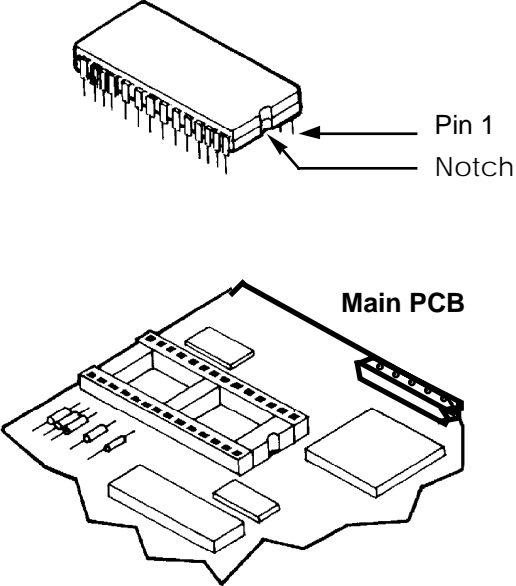
Step	Action
<p>10</p>	<p>With component side of new PWA facing you, align notch and pin 1 of new PROM with notch and pin 1 in IC socket on PWA. Carefully plug PROM into socket.</p>  <p>The diagram consists of two parts. The upper part shows a perspective view of a PROM chip. It has two rows of pins. An arrow points to the first pin on the right side, labeled 'Pin 1'. Another arrow points to a small notch on the top edge of the chip, labeled 'Notch'. The lower part shows a perspective view of a 'Main PCB' (Printed Wiring Board). It features a large IC socket with a notch on its top edge, corresponding to the notch on the PROM chip. Other components and traces are visible on the board.</p>
<p>11</p>	<p>Reverse actions in Steps 2, 3, 4, and 5 to return electronics module to housing. We recommend that you lubricate end-cap O-ring with silicon grease such as Dow Corning #33 or equivalent before you replace end cap.</p>
<p>12</p>	<p>Return transmitter to service and turn ON power.</p>
<p>13</p>	<p>Verify transmitter's configuration data. Recalibrate transmitter to achieve highest accuracy; if this is not convenient, reset calibration (See Section 10.5 in this manual) for PV1 and PV2, and do an input zero correction for PV1 to compensate for any minor error. Also, check PV3 zero point.</p>

9.5 Replacing Meter Body Center Section

Procedure

You can replace the center section of the meter body. A replacement center section is supplied with a new matching PROM.

Use the procedure in Table 29 to install a new center section and its matching PROM.

Table 29 Replacing Meter Body Center Section

Step	Action
1	Complete first 7 Steps, as applicable, in Table 28 to remove electronics module, remove existing PROM, and install matching PROM supplied with new meter body center section.
2	Use 4mm size allen wrench to loosen set screw outside housing.
3	Carefully unscrew meter body including integral flex-tape assembly counterclockwise from electronics housing.

The diagram illustrates the removal of the meter body center section. It is divided into three parts: 1. The top part shows a perspective view of the meter body with a circular slot on its top surface, labeled 'Slot for Set Screw'. 2. The middle part shows a cross-section of the center section being lifted out of the meter body, labeled 'Center Section'. 3. The bottom part shows the meter body with two 'Process Heads' indicated by arrows, labeled 'Process Heads' and 'Meter Body'.

Continued on next page

9.5 Replacing Meter Body Center Section, Continued

Procedure, continued

Table 29 Replacing Meter Body Center Section, Continued

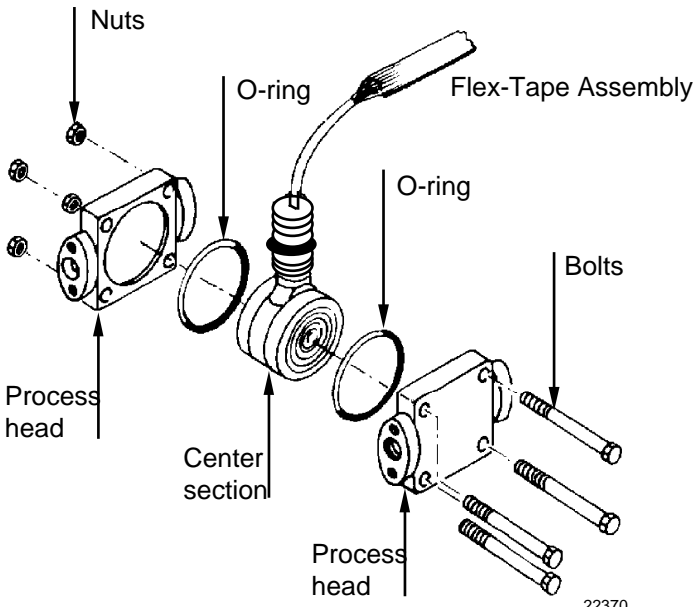
Step	Action
4	Remove nuts from bolts that hold process heads to center section. Remove process heads and bolts
5	Remove O-ring and clean interior of process head using soft bristle brush and suitable solvent.
6	Replace O-ring.
7	Coat threads on process head bolts with anti-seize compound such as "Neverseize" or equivalent.
8	<p>Carefully assemble process heads and bolts to new center section. Finger tighten nuts.</p> 

Continued on next page

9.5 Replacing Meter Body Center Section, Continued

Procedure, continued

Table 29 Replacing Meter Body Center Section, Continued

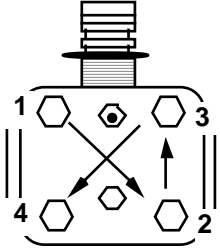
Step	Action
<p>9</p>	<p>Use a torque wrench to gradually tighten nuts to torque of 40 ft-lb (54 N•m) for carbon steel process heads bolts or 35 ft-lb (47.5 N•m) for stainless steel process head bolts in sequence shown in following illustration. Tighten head bolts in stages of 1/3 full torque, 2/3 full torque, and then full torque.</p> <p>Always tighten head bolts in sequence shown and in these stages:</p> <ol style="list-style-type: none"> 1. 1/3 full torque 2. 2/3 full torque 3. Full torque  <p style="text-align: right; font-size: small;">22519</p>
<p>10</p>	<p>Feed flex-tape assembly on new meter body center section through neck of housing and screw meter body clockwise into housing.</p>
<p>11</p>	<p>Rotate housing to desired position and tighten outside set screw. Be sure set screw seats fully into set screw slot.</p>
<p>12</p>	<p>See Step 11 in Table 28.</p>
<p>13</p>	<p>Verify transmitter's configuration data. Recalibrate transmitter to achieve highest accuracy; if this is not convenient, reset calibration (See Section 10.6 in this manual) for PV1 and PV2, and do an input zero correction for PV1 to compensate for any minor error. Also, check PV3 zero point.</p>

Section 10 — Calibration

10.1 Introduction

Section Contents

This section includes these topics

Topic	See Page
10.1 Introduction	111
10.2 Overview	112
10.3 Calibrating Analog Output Signal.....	114
10.4 Calibrating PV1 and PV2 Range Values.....	115
10.5 Resetting Calibration	117

About This Section

This section provides information about calibrating the transmitter's analog output and measurement ranges for differential pressure PV1 and static pressure PV2. It also covers the procedure for resetting calibration to default values as a quick alternative to measurement range calibration.

10.2 Overview

About Calibration

Differential pressure and static pressure measurements can be affected by conditions external to the transmitter, (such as process material or residue adhering to barrier diaphragms for example), so measurement “drift” cannot be eliminated completely. If recalibration of the differential pressure PV1 and/or static pressure PV2 measurement range is required, we recommend that you do a bench calibration with the transmitter removed from the process and located in a controlled environment to get the best accuracy.

For a transmitter with a small differential pressure span, a input zero correct function should be performed. This action corrects for any minor error that may occur after the transmitter is mounted and connected to the process.

If the transmitter will be operating in the analog mode, you must calibrate its output signal before you calibrate the transmitter’s measurement ranges. While it is not required to calibrate the output signal first for transmitter's operating in the DE mode, you can do it by reading the output in percent.

You can reset the calibration data for any given measurement range to default values, if it is corrupted, until the transmitter can be recalibrated. See subsection 10.5 for details.

Continued on next page

10.2 Overview, Continued

Test Equipment Required

Depending upon the type of calibration you choose, you may need any of the following test equipment to accurately calibrate the transmitter:

- Digital Voltmeter or milliammeter with 0.02% accuracy or better
 - SFC Smart Field Communicator or a PC running SCT 3000 software
 - Calibration-standard input source with a 0.02% accuracy
 - 250 ohm resistor with 0.01% tolerance or better.
-

Using the SFC or SCT for Calibration

Transmitter calibration can be accomplished by using either the SCT 3000 (which is recommended) or a Smart Field Communicator (SFC).

Using the SCT, calibration procedures for the SMV 3000 are available in the on-line user manual. Step procedures for calibrating the SMV 3000 using the SFC can be found in the *Smart Field Communicator Model STS103 Operating Guide*, 34-ST-11-14.

ATTENTION

If the transmitter is digitally integrated with our TPS/TDC 3000 control systems, you can initiate range calibration and calibration reset functions through displays at the Universal Station. However, we still recommend that you do a range calibration using the SCT with the transmitter removed from service and moved to a controlled environment. Details about doing a calibration reset through the Universal Station are given in the *PM/APM Smartline Transmitter Integration Manual*, PM12-410 which is part of the TDC 3000 system bookset.

10.3 Calibrating Analog Output Signal

Background

You can calibrate the transmitter's analog output circuit at its 0 and 100% levels by using the transmitter in its constant-current source mode (or output mode). It is not necessary to remove the transmitter from service for this procedure.

Procedure

Depending if you are using the SCT 3000 or the SFC to perform calibration, refer to the appropriate sections below for the procedure. The procedure shows you how to calibrate the output signal for a transmitter in the analog mode. Note that the procedure is similar for a transmitter in the DE mode, but the SCT (or SFC) must be used to read the output in percent in place of the milliammeter or voltmeter readings.

See Figure 28 for a sample test equipment setup.

Using the SCT, select the topic:

“Calibrating Output at 0 and 100% for an SMV 3000 Transmitter” and Click on “PV4 Output Calibration Form (FLOW OutCal)” to view the procedure.

Using the SFC:

Follow the procedure for “Calibrating the Output Signal for Transmitter in Analog Mode” in Section 7 of the SFC Operating Guide.

10.4 Calibrating PV1 and PV2 Range Values

Background

The SMV 3000 Smart Multivariable Transmitter has two-point calibration. This means when you calibrate two points in the PV range all the points in that range adjust to that calibration.

ATTENTION

You must have a precision pressure source with an accuracy of 0.04% or better to do a range calibration. Note that we factory calibrate SMV 3000 Smart Multivariable Transmitters with inches of water ranges using inches of water pressure referenced to a temperature of 39.2 °F (4°C).

Procedure

Depending if you are using the SCT 3000 or the SFC to perform calibration, refer to the appropriate sections below for the procedure. The procedures show you how to calibrate the PV1 and PV2 ranges (LRV and URV) of the transmitter. This procedure assumes that the transmitter is removed from the process and located in a controlled environment.

See Figure 28 for typical SCT/SFC, power supply, and pressure source hookup for calibration.

Using the SCT, select the topic:

“Calibrating LRV and URV for an SMV 3000 Transmitter” and Click on “Input Calibration – (for the desired PV listed in the menu)”.

The procedure for setting PV1 range is viewed by selecting “Steps to Calibrate LRV and URV for PV1”.

The procedure for setting PV2 range is viewed by selecting either “Calibration Procedure Using an Absolute Pressure (Vacuum) Source” or “Calibration Procedure Using a Gauge Pressure Source with an Absolute Pressure Readout”.

Using the SFC:

Follow the procedure for “Calibrating Measurement Range for PV1” and “Calibrating Measurement Range for PV2” in Section 7 of the SFC Operating Guide.

10.4 Calibrating PV1 and PV2 Range Values, Continued

Procedure, continued

Figure 28 Typical PV1 or PV2 Range Calibration Hookup

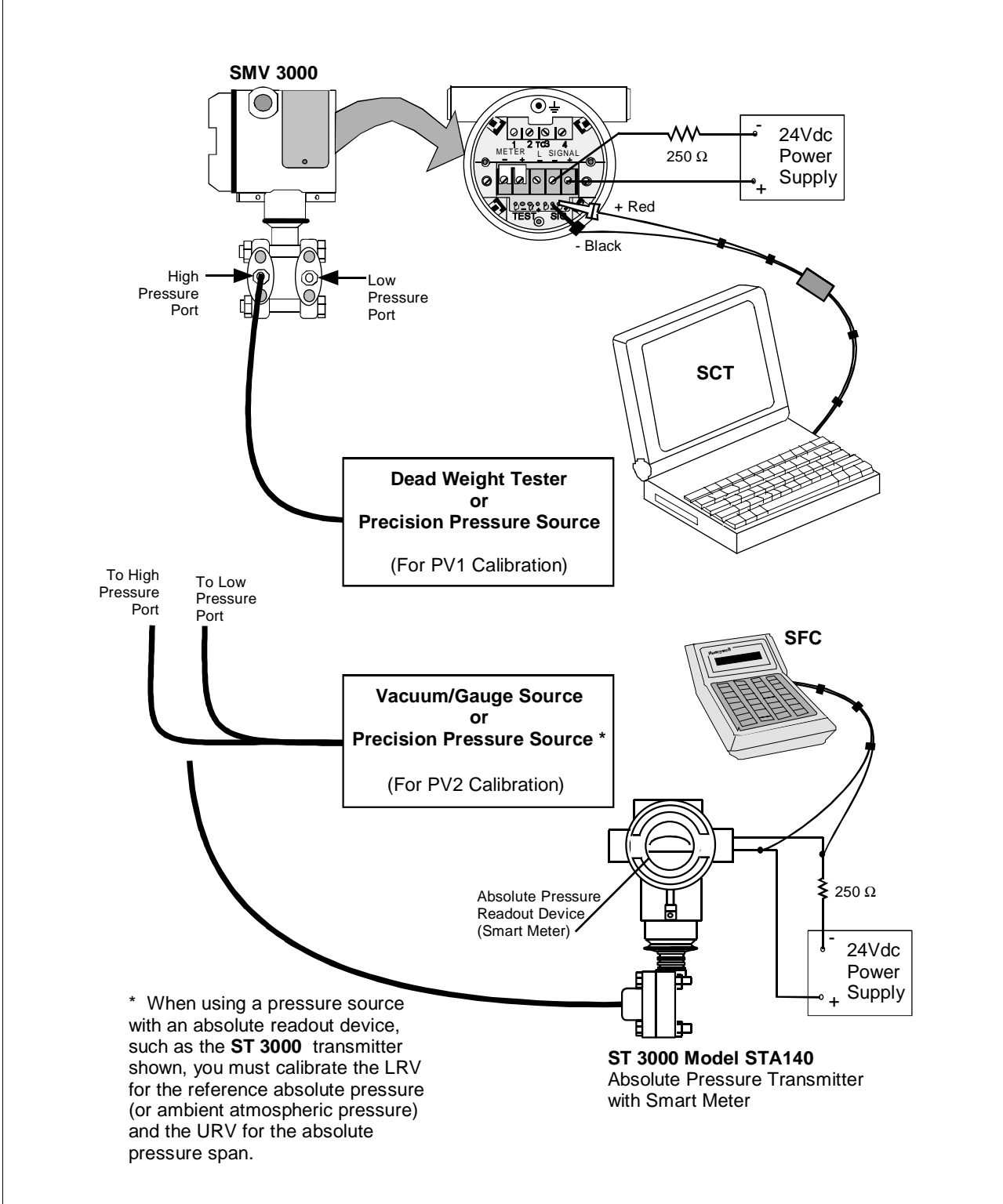

Continued on next page

10.5 Resetting Calibration

About Reset Accuracy for PV1 and PV2

You can erase incorrect PV1 and/or PV2 calibration data by resetting the data to default values. The default values return the transmitter calibration to the original factory “characterization” values for the existing LRV and URV. Characterization calculates a mathematical model of the performance of the transmitter’s sensors and then stores that data in the transmitter’s memory. Note that this is **not** the “final calibration” which is done at the end of the process against the ordered range.

While resetting the calibration will return the transmitter to a close approximation of the previous calibration using its stored characterization data, the accuracy of the “reset” transmitter will be lower than the specified final calibrated accuracy. The calibration is not exact since the transmitter mounting angle may be different than the factory mounting angle and time drift may have occurred since the factory characterization. This means that the transmitter is calculating its output based on the characterization equation alone without any compensation for the small residual errors of zero offset and span correction.

For example, a typical zero offset correction is less than 0.1 inH₂O for a 400 inH₂O range and a typical span correction is less than 0.2% regardless of the range (down to the point where specification turndown begins). The typical performance of a 400 inH₂O transmitter after a calibration reset (or a “Corrects Reset” as it is often called) can be expressed as:

$$\text{Accuracy} = 0.2\% + \left(\frac{0.1 \text{ inH}_2\text{O}}{\text{Span inH}_2\text{O}} \right) \cdot 100\%$$

By correcting the zero input, the typical performance will be 0.2% or better.

For other transmitter ranges, the initial zero offset will be scaled by the ratio of the Upper Range Limit (URL) to 400 inH₂O at 39.2 °F (4 °C). Thus, for a 100 psi range, the initial zero offset can be expressed by:

$$0.1 \text{ inH}_2\text{O} \cdot \frac{2768 \text{ inH}_2\text{O}}{400 \text{ inH}_2\text{O}} = 0.7 \text{ inH}_2\text{O} \text{ or } 0.025 \text{ psi}$$

Note that these are **typical** values and they may vary. However, our patented characterization method includes several techniques that help to ensure that this level of performance can be achieved.

Continued on next page

10.5 Resetting Calibration, Continued

Background

You can erase incorrect calibration data for a given PV measurement range by resetting the data to default values using the SCT or SFC.

Procedure

Depending if you are using the SCT 3000 or the SFC to reset calibration, refer to the appropriate sections below for the procedure. The procedure shows you how to reset calibration data for a given PV measurement range in a transmitter.

Using the SCT, select the topic:

“Resetting Calibration for an SMV 3000 Transmitter”

Using the SFC:

Follow the procedure for “Steps to Reset Calibration Data for an SMV 3000” in Section 7 of the SFC Operating Guide.

Section 11 —Troubleshooting

11.1 Introduction

Section Contents

This section includes these topics

Topic	See Page
11.1 Introduction	119
11.2 Overview	120
11.3 Troubleshooting Using the SCT	121
11.4 Diagnostic Messages	122

About This Section

This section shows you how to use the SCT 3000 to access diagnostic messages generated by the SMV 3000. The SCT on-line user manual and help provides details for interpreting diagnostic messages and the steps to correct fault conditions.

11.2 Overview

Diagnostics

The SMV 3000 transmitter is constantly running internal diagnostics to monitor sensor and transmitter functions. The SCT and SFC, when connected to the SMV control loop, monitor the transmitter functions, and status of the control loop and the communications link.

When a diagnostic failure is detected, a status is generated by the SMV. The SCT or SFC, connected to the SMV control loop, will interpret the transmitter status into messages which can be viewed through the SCT Status tab card or an SFC display. Corrective actions then can be taken to clear transmitter fault conditions.

ATTENTION

There are additional diagnostics provided by the STIMV IOP for transmitters integrated with the TPS/TDC control systems and any message will appear in the TRANSMITTER STATUS field of the Detail Display in the Universal Station. Details about the STIMV IOP diagnostic messages are given in the *PM/APM Smartline Transmitter Integration Manual PM12-410* which is part of the TPS/TDC system bookset and in Appendix A of this manual.

Troubleshooting Tools

Your primary troubleshooting tool is the SCT in which you can run a status check and refer to the detailed status message table that lists the diagnostic messages and their meanings. Recommended actions are provided to help in correcting transmitter fault conditions. Use the SCT also to verify the transmitter's configuration data and check to be sure your process is operating correctly.

NOTE: The SFC can also be used to check transmitter status and identify diagnostic messages. If you are using an SFC to check transmitter status and diagnose transmitter faults, refer to the *Smart Field Communicator Model STS103 Operating Guide 34-ST-11-14* for detailed keystroke information and trouble shooting procedures.

11.3 Troubleshooting Using the SCT

Summary

Using the SCT in the on-line mode you can check the transmitter status, identify diagnostic messages and access troubleshooting information so you can clear fault conditions.

The SMV diagnostic messages fall into any one of the following general categories:

- Status (Informational)
 - Noncritical Status
 - Critical Status
 - Communications
-

Follow the steps in Table 30 to access diagnostic messages generated by the SMV 3000 and procedures for clearing transmitter fault conditions.

Table 30 Accessing SMV 3000 Diagnostic Information using the SCT

Step	Action
1	Connect the SCT to the SMV and establish communications. (See Subsection 5.2 Establishing Communications for the procedure, if necessary.)
2	Select the Status Tab Card (if not selected already) to display a listing of the Gross Status and Detailed Status messages.
3	Refer to the SCT on-line user manual for descriptions of the status messages and corrective actions to clear faults.

ATTENTION

When critical status forces PV output into failsafe condition, record the messages before you cycle transmitter power OFF/ON to clear failsafe condition.

11.4 Diagnostic Messages

Diagnostic Messages The diagnostic text messages that can be displayed on the SCT, SFC or on a TPS/TDC system are listed in the following tables. A description of the probable cause and suggested action to be taken are listed also to help in troubleshooting error conditions.

The messages are grouped in tables according to the status message categories.

Table 31 lists	Critical status diagnostic messages
Table 32 -	Non-critical status messages
Table 33 -	Communications status messages
Table 34-	Informational status messages
Table 35-	SFC Diagnostic messages

Diagnostic Message Table Headings

SMV Status column provides the location of the SMV status. If you are using one of the diagnostic tools (SCT, SFC or Universal Station) that contains an earlier software version, you may see the diagnostic messages displayed as these SMV Status numbers.

The **SCT Status Message** column shows the text which appears in the Status tab window when the SCT is in the on-line mode and connected to the SMV control loop.

The **SFC Display Message** column shows the text which appears when the SFC is connected to the SMV control loop and the [STAT] key is pressed.

TDC Display Status Message column shows the text which appears on a TPS/TDC Universal Station.

Some messages and information in the tables are specific to the SCT or SFC and are noted.

Continued on next page

11.4 Diagnostic Messages, Continued

Diagnostic Messages, continued Table 31 Critical Status Diagnostic Message Table

SMV Status	SCT Status Message	SFC Display Message	TDC Status Message	Possible Cause	What to Do
7-0	A/D Failure PV3	STATUS TAG ID.# A/D FAILURE PV3	A/D FAILURE PV3	A/D circuit for PV3 input has failed.	<ul style="list-style-type: none"> • Cycle transmitter power OFF/ON. • Replace electronics module.
7-1	Characterization Fault PV3	STATUS TAG ID.# CHAR. FAULT PV3	CHAR. FAULT PV3	Characterization data for PV3 is bad.	<ul style="list-style-type: none"> • Cycle transmitter power OFF/ON. • Replace electronics module.
1-1	Characterization PROM Fault or Bad Checksum	STATUS TAG ID. CHAR PROM FAULT	CHAR PROM FAULT	Characterization data is bad.	Replace PROM with an identical PROM. Verify PROM serial number: SCT – Select Device tab card. SFC – Press [CONF] and [▲ NEXT] keys.
1-3	DAC Compensation Fault Error Detected	STATUS TAG ID.# DAC COMP FAULT	DAC COMP FAULT	DAC temperature compensation is out of range.	Replace electronics module.
1-4	NVM Fault PV1	STATUS TAG ID.# NVM FAULT	NVM FAULT	PV1 nonvolatile memory fault.	Replace electronics module.
1-5	RAM Fault	STATUS TAG ID. RAM FAULT	RAM FAULT	RAM has failed	Replace electronics module
1-6	PROM Fault	STATUS TAG ID. PROM FAULT	PROM FAULT	PROM has failed.	Replace PROM.
1-7	PAC Fault	STATUS TAG ID. PAC FAULT	PAC FAULT	PAC circuit has failed.	Replace electronics module.

Continued on next page

11.4 Diagnostic Messages, Continued

Diagnostic Messages, continued Table 31 Critical Status Diagnostic Message Table, Continued

SMV Status	SCT Status Message	SFC Display Message	TDC Status Message	Possible Cause	What to Do
2-4 2-5	Meter Body Overload OR Meter Body Fault: Pressure >2*URL	STATUS TAG ID.# M.B. OVERLOAD OR STATUS TAG ID.# METERBODY FAULT	M.B. OVERLOAD OR METER BODY FAULT	Pressure input is two times greater than URL for PV2.	<ul style="list-style-type: none"> • Wait for PV2 range to return to normal. • Meter body may have been damaged. Check the transmitter for accuracy and linearity. Replace meter body center and recalibrate if needed.
8-3	Input Open PV3	STATUS TAG ID. INPUT OPEN PV3	INPUT OPEN PV3	Temperature input TC or RTD is open.	Replace the thermocouple or RTD.
1-2	Input Suspect	OUTP 1 TAG ID. SUSPECT INPUT	SUSPECT INPUT	PV1 and PV2 or sensor temperature input data seems wrong. Could be a process problem, but it could also be a meter body or electronics module problem.	<ul style="list-style-type: none"> • Cycle transmitter power OFF/ON. • Put transmitter in PV1 output mode check transmitter status. Diagnostic messages should identify where problem is. If no other diagnostic message is given, condition is most likely meter body related. • Check installation and replace meter body center section. If condition persists, replace electronics module.
3-1	Input Suspect PV2	OUTP 1 TAG ID. SUSPCT INPUT PV2	SUSPCT INPUT PV2	PV2 Input data seems wrong. Could be a process problem, but it could also be a meter body or electronics module problem.	<ul style="list-style-type: none"> • Cycle transmitter power OFF/ON. • Put transmitter in PV2 output mode and check transmitter status. Diagnostic messages should identify where problem is. If no other diagnostic message is given, condition is most likely meter body related. • Check installation and replace meter body center section. If condition persists, replace electronics module.

11.4 Diagnostic Messages, Continued

Diagnostic Messages, continued Table 31 Critical Status Diagnostic Message Table, Continued

SMV Status	SCT Status Message	SFC Display Message	TDC Status Message	Possible Cause	What to Do
7-2	Input Suspect PV3	OUTP 1 TAG ID. SUSPCT INPUT PV3	-	PV3 Input data seems wrong. Sensor reading is extremely erratic. Could be a process problem, but it could also be a temperature sensor or electronics module problem.	<ul style="list-style-type: none"> • Cycle transmitter power OFF/ON. • Check sensor leads for weak area that may be ready to break or loose connection.
3-0	Invalid Database	TAG NO. INVALID DATABASE	INVALID DATABASE	Transmitter database was incorrect at power-up.	<ul style="list-style-type: none"> • Try communicating again. • Verify database configuration, and then manually update non-volatile memory.
7-4	NVM Fault PV3	STATUS TAG ID. NVM FAULT PV3	NVM FAULT PV3	PV3 nonvolatile memory fault.	Replace electronics module.
8-4	Over Range PV3	STATUS TAG ID. OVERRANGE PV3	OVERRANGE PV3	Process temperature exceeds PV3 range.	<ul style="list-style-type: none"> • Check process temperature. Reduce temperature, if required. • Replace temperature sensor, if needed.
9-0	PV4 (Flow) Algorithm Parameters Invalid	STATUS TAG ID.# ALGPARM INVALID	STATUS 9-0	Configuration for selected equation is not complete.	Check the flow configuration using the SCT flow compensation wizard.
3-3	PV4 in failsafe	-	STATUS 3-3	An algorithm diagnostic has determined the flow to be invalid.	<ul style="list-style-type: none"> • Resolve the conditions causing the other diagnostic message. • Check all flow configuration parameters.

Continued on next page

11.4 Diagnostic Messages, Continued

Diagnostic Messages, continued Table 32 Non-Critical Status Diagnostic Message Table

SMV Status	SCT Status Message	SFC Display Message	TDC Status Message	Possible Cause	What to Do
9-3	Bad AP Compensation PV4	STATUS TAG ID.# BAD AP COMP PV4	BAD AP COMP PV4	Problem with absolute/gauge pressure input PV2 or input processing circuitry for PV2.	<ul style="list-style-type: none"> Verify that absolute/gauge pressure input is correct for selected flow equation. If error persists, replace transmitter.
9-4	Bad PT Compensation PV4	STATUS TAG ID.# BAD PT COMP PV4	BAD PT COMP PV4	Problem with process temperature input PV3, input processing circuitry for PV3, or PV4 algorithm parameter data.	<ul style="list-style-type: none"> Verify that process temperature input is correct. Verify open/defective temperature sensor. Correct process temperature measurement. Check for temperature limits exceeded in viscosity or density configuration. Check design temperature value for PV4 standard gas algorithm.
2-6	Corrects Reset PV1	STATUS TAG ID.# CORRECTS RST PV1	CORRECTS RST PV1	All calibration "CORRECTS" were deleted and data was reset for PV1 range.	Recalibrate PV1 (DP) range.
4-6	Corrects Reset PV2	STATUS TAG ID.# CORRECTS RST PV2	CORRECTS RST PV2	All calibration "CORRECTS" were deleted and data was reset.	Recalibrate PV2 (SP) range.
8-6	Corrects Active on PV3	STATUS TAG ID.# CORR. ACTIVE PV3	CORR. ACTIVE PV3	Process temperature PV3 has been calibrated and is now different than factory default (uncalibrated).	Nothing – or do a reset corrects

Continued on next page

11.4 Diagnostic Messages, Continued

Diagnostic Messages, continued Table 32 Non-Critical Status Diagnostic Message Table, continued

SMV Status	SCT Status Message	SFC Display Message	TDC Status Message	Possible Cause	What to Do
9-6	Corrects Active on PV4	STATUS TAG ID.# CORR. ACTIVE PV4	CORR. ACTIVE PV4	Calculated flow rate PV4 has been calibrated.	Nothing – or do a reset corrects.
3-6	Density temperature or pressure out of range	-	STATUS 3-6	Either the temperature (PV3) or the pressure (PV2) is not within the boundaries of SMV steam equation. The SMV steam equation is defined for pressures between 8 and 3000 psia, and temperature between saturation and 1500 °F, except above 2000 psia.	Check to see if the PV measurement is correct.
2-2	Excess Span Correct PV1 Or Span Correction is Out of Limits	STATUS TAG ID.# EX. SPAN COR PV1	EX. SPAN COR PV1	SPAN correction factor is outside acceptable limits for PV1 range. Could be that transmitter was in input or output mode during a CORRECT procedure.	<ul style="list-style-type: none"> Verify calibration. If error persists, call the Solutions Support Center
4-2	Excess Span Correct PV2	STATUS TAG ID.# EX. SPAN COR PV2	EX. SPAN COR PV2	SPAN correction factor is outside acceptable limits for PV2 range. Could be that transmitter was in input or output mode during a CORRECT procedure.	<ul style="list-style-type: none"> Verify calibration. If error persists, call the Solutions Support Center
8-2	Excess Span Correct PV3	STATUS TAG ID.# EX. SPAN COR PV3	EX. SPAN COR PV3	SPAN correction factor is outside acceptable limits for PV3 range.	<ul style="list-style-type: none"> Verify calibration. If error persists, call the Solutions Support Center
9-2	Excess Span Correct PV4	STATUS TAG ID.# EX. SPAN COR PV4	EX. SPAN COR PV4	SPAN correction factor is outside acceptable limits for PV4 range.	<ul style="list-style-type: none"> Verify calibration. If error persists, call the Solutions Support Center

11.4 Diagnostic Messages, Continued

Diagnostic Messages, continued Table 32 Non-Critical Status Diagnostic Message Table, continued

SMV Status	SCT Status Message	SFC Display Message	TDC Status Message	Possible Cause	What to Do
2-1	Excess Zero Correct PV1 Or Zero Correction is Out of Limits	STATUS TAG ID.# EX. ZERO COR PV1	EX. ZERO COR PV1	ZERO correction factor is outside acceptable limits for PV1 range. Could be that transmitter was in input or output mode during a CORRECT procedure.	<ul style="list-style-type: none"> Verify calibration. If error persists, call the Solutions Support Center
4-1	Excess Zero Correct PV2	STATUS TAG ID.# EX. ZERO COR PV2	EX. ZERO COR PV2	ZERO correction factor is outside acceptable limits for PV2 range. Could be that transmitter was in input or output mode during a CORRECT procedure.	<ul style="list-style-type: none"> Verify calibration. If error persists, call the Solutions Support Center
8-1	Excess Zero Correct PV3	STATUS TAG ID.# EX. ZERO COR PV3	EX. ZERO COR PV3	ZERO correction factor is outside acceptable limits for PV3 range.	<ul style="list-style-type: none"> Verify calibration. If error persists, call the Solutions Support Center
9-1	Excess Zero Correct PV4	STATUS TAG ID.# EX. ZERO COR PV4	EX. ZERO COR PV4	ZERO correction factor is outside acceptable limits for PV4 range.	<ul style="list-style-type: none"> Verify calibration. If error persists, call the Solutions Support Center
9-5	In Cutoff PV4	STATUS TAG ID.# IN CUTOFF PV4	IN CUTOFF PV4	Calculated flow rate is within configured low and high limits for PV4 low flow cutoff.	Nothing – wait for flow rate to exceed configured high limit. Verify that flow rate is in cutoff.
5-4	Input Mode PV1 (DP)	STATUS TAG ID.# INPUT MODE PV1	INPUT MODE PV1	Transmitter is simulating input for PV1.	Exit Input mode: SCT – Press “Clear Input Mode” button on the DP InCal tab. SFC – Press [SHIFT], [INPUT], and [CLR] keys.

11.4 Diagnostic Messages, Continued

Diagnostic Messages, continued Table 32 Non-Critical Status Diagnostic Message Table, continued

SMV Status	SCT Status Message	SFC Display Message	TDC Status Message	Possible Cause	What to Do
5-5	Input Mode PV2 (AP)	STATUS TAG ID.# INPUT MODE PV2	INPUT MODE PV2	Transmitter is simulating input for PV2.	Exit Input mode: SCT – Press “Clear Input Mode” button on the AP InCal tab. SFC – Press [SHIFT], [INPUT], and [CLR] keys.
5-6	Input Mode PV3 (Temp)	STATUS TAG ID.# INPUT MODE PV3	INPUT MODE PV3	Transmitter is simulating input for PV3.	Exit Input mode: SCT – Press “Clear Input Mode” button on the TEMP InCal tab. SFC – Press [SHIFT], [INPUT], and [CLR] keys.
5-7	Input Mode PV4 (Flow)	STATUS TAG ID.# INPUT MODE PV4	INPUT MODE PV4	Transmitter is simulating input for PV4.	Exit Input mode: SCT – Press “Clear Input Mode” button on the FLOW InCal tab. SFC – Press [SHIFT], [INPUT], and [CLR] keys.
2-0	Meter Body Sensor Over Temperature	STATUS TAG ID.# M.B. OVERTEMP	M.B. OVERTEMP	Sensor temperature is too high (>125 °C). Accuracy and life span may decrease if it remains high.	Take steps to insulate meter body from temperature source.
2-7	No DAC Temp Comp Or DAC Temperature Compensation data is corrupt	STATUS TAG ID.# NO DAC TEMPCOMP	NO DAC TEMP COMP	Failed DAC.	Replace electronics module.

11.4 Diagnostic Messages, Continued

Diagnostic Messages, continued Table 32 Non-Critical Status Diagnostic Message Table, Continued

SMV Status	SCT Status Message	SFC Display Message	TDC Status Message	Possible Cause	What to Do
6-4	Output Mode PV1 (DP)	STATUS TAG ID.# OUTPUT MODE PV1	OUTPUT MODE PV1	Analog transmitter is operating as a current source for PV1 output.	Exit Output Mode: SCT – Press “Clear Output Mode” button on the DP OutCal tab. SFC – Press [OUTPUT] and [CLR] keys.
6-5	Output Mode PV2 (SP)	STATUS TAG ID.# OUTPUT MODE PV2	OUTPUT MODE PV2	Analog transmitter is operating as a current source for PV2 output.	Exit Output Mode: SCT – Press “Clear Output Mode” button on the AP OutCal tab. SFC – Press [OUTPUT] and [CLR] keys.
6-6	Output Mode PV3 (Temp)	STATUS TAG ID.# OUTPUT MODE PV3	OUTPUT MODE PV3	Analog transmitter is operating as a current source for PV3 output.	Exit Output Mode: SCT – Press “Clear Output Mode” button on the TEMP OutCal tab. SFC – Press [OUTPUT] and [CLR] keys.
6-7	Output Mode PV4 (Flow)	STATUS TAG ID.# OUTPUT MODE PV4	OUTPUT MODE PV4	Analog transmitter is operating as a current source for PV4 output.	Exit Output Mode: SCT – Press “Clear Output Mode” button on the FLOW OutCal tab. SFC – Press [OUTPUT] and [CLR] keys.
3-7	PV4 Independent variable out of range	-	STATUS 3-7	For R250 Laminar Flow transmitters only. Asserted when a PV is not within the range of a term in the laminar Flow equation.	<ul style="list-style-type: none"> • Check the value of every PV against the ranges in the Laminar Flow equation. • Redefine the equation, if necessary.

11.4 Diagnostic Messages, Continued

Diagnostic Messages, continued Table 32 Non-Critical Status Diagnostic Message Table, Continued

SMV Status	SCT Status Message	SFC Display Message	TDC Status Message	Possible Cause	What to Do
9-7	Reynolds Number is Out of Range	-	STATUS 9-7	The high or low Reynolds number limit was exceeded.	<ul style="list-style-type: none"> Verify high or low Reynolds number limit. Calculate Reynolds number for flow conditions causing the message.
8-7	Sensor Mismatch PV3	SAVE/RESTORE TYPE MISMATCH	SNSR MISMTCH PV3	Number of wires selected does not match number of sensor wires physically connected to the transmitter.	Check sensor wiring and type.

11.4 Diagnostic Messages, Continued

Diagnostic Messages, continued Table 33 Communication Status Message Table

SMV Status	SCT Status Message	SFC Display Message	TDC Status Message	Possible Cause	What to Do
-	Command Aborted	TAG NO. COMM ABORTED	-	Communications aborted. SFC – Pressed [CLR] key during communications operation.	Retry aborted operation.
-	Communication Error Upload failed	TAG NO. END AROUND ERR	-	Communications unsuccessful.	<ul style="list-style-type: none"> • Check loop wiring and STC/SFC connections. • If error persists, replace transmitter electronics module.
-	Download Failed	SAVE/RESTORE RESTORE FAILED	-	Database restore or download function failed due to a problem with the current configuration or a communications error.	Check transmitter and try again.
-	Invalid Response	TAG NO. ILLEGAL RESPONSE	-	The transmitter did not respond properly since the response was not recognizable. The message was probably corrupted by external influences. Transmitter sent illegal response to SCT or SFC.	Try communicating again.
-	Illegal operation	URV 3 . TAG ID. INVALID REQUEST	-	Requesting transmitter to correct or set its URV to a value that results in too small a span, or correct its LRV or URV while in input or output mode.	• Check that correct URV calibration pressure is being applied to transmitter, or that transmitter is not in input or output mode.
SFC – Keystroke is not valid for given transmitter.				Check that keystroke is applicable for given transmitter.	
SCT – The requested transaction is not supported by the transmitter.				Make sure the device version is compatible with the current release of the SCT 3000.	

11.4 Diagnostic Messages, Continued

Diagnostic Messages, continued Table 33 Communication Status Message Table, continued

SMV Status	SCT Status Message	SFC Display Message	TDC Status Message	Possible Cause	What to Do
-	-	STATUS TAG ID. NACK RESPONSE	-	Transmitter sent a negative response because it could not process one or more commands.	Check configuration and try again.
-	-	TAG NO. FAILED COMM CHK	-	SFC failed a communications diagnostic check. Could be an SFC electronic problem or a faulty or dead communication loop.	<ul style="list-style-type: none"> • Check polarity and try again. • Press [stat] key and do any corrective action required and try again. • Check communication loop. • Replace SFC.
-	-	TAG NO. HI RES/LO VOLT	-	Either there is too much resistance in loop (open circuit), voltage is too low, or both.	<ul style="list-style-type: none"> • Check polarity, wiring, and power supply. There must be 11 volts minimum at transmitter to permit operation. • Check for defective or misapplied capacitive or inductive devices (filters).
-	-	TAG NO. NO XMTR RESPONSE	-	No response from transmitter. Could be transmitter or loop failure.	<ul style="list-style-type: none"> • Try communicating again. • Check that transmitter's loop integrity has been maintained, that SCT or SFC is connected properly, and that loop resistance is at least 250Ω. <p>SCT – Select Tag ID from the View pull down menu.</p> <p>SFC – Press [ID] key and do any corrective action required and try again.</p>

11.4 Diagnostic Messages, Continued

Diagnostic Messages, continued Table 34 Informational Status Message Table

SMV Status	SCT Status Message	SFC Display Message	TDC Status Message	Possible Cause	What to Do
6-3	2 Wire TC PV3	STATUS TAG ID. 2 WIRE TC PV3	2 WIRE TC PV3	PV3 input is being provided by 2-wire Thermocouple (T/C) type.	Nothing – Information only. However, this may indicate a problem if sensor type does not match the sensor physically connected to transmitter.
6-0	2 Wire RTD PV3	STATUS TAG ID. 2 WIRE RTD PV3	2 WIRE RTD PV3	PV3 input is being provided by 2-wire RTD type.	Nothing – Information only. However, this may indicate a problem if number of wires displayed does not match number of RTD leads physically connected to transmitter; or if sensor type should be thermocouple.
6-1	3 Wire RTD PV3	STATUS TAG ID. 3 WIRE RTD PV3	3 WIRE RTD PV3	PV3 input is being provided by 3-wire RTD type.	Nothing – Information only. However, this may indicate a problem if number of wires displayed does not match number of RTD leads physically connected to transmitter; or if sensor type should be thermocouple.
6-2	4 Wire RTD PV3	STATUS TAG ID. 4 WIRE RTD PV3	4 WIRE RTD PV3	PV3 input is being provided by 4-wire RTD type.	Nothing – Information only. However, this may indicate a problem if number of wires displayed does not match number of RTD leads physically connected to transmitter; or if sensor type should be thermocouple.
4-3	PV2 Sensor = AP	-	STATUS 4-3	Sensor type for the current SMV is absolute pressure.	Nothing – Information only.
4-4	PV2 Sensor = GP	-	STATUS 4-4	Sensor type for the current SMV is gauge pressure.	Nothing – Information only.
-	Write Protected	URV 1 . TAG ID. WRITE PROTECTED	-	The value could not be written because the transmitter is write protected.	The hardware jumper within the device must be repositioned in order to permit write operations.

11.4 Diagnostic Messages, Continued

Diagnostic Messages, continued Table 35 SFC Diagnostic Message Table

SMV Status	SCT Status Message	SFC Display Message	TDC Status Message	Possible Cause	What to Do
-	-	ALGPARM Kuser ≥RANGE	-	Applicable PV4 algorithm parameter is set to default value of not-a-number (NaN).	Enter and download desired value to transmitter database.
-	-	SAVE/RESTORE H.W. MISMATCH	-	Hardware mismatch. Part of Save/Restore function.	None – SFC tried to restore as much of database as possible.
-	-	STATUS TAG ID. NVM ON SEE MAN	-	SFC's CPU is misconfigured.	Replace SFC.
-	-	SAVE/RESTORE OPTION MISMATCH	-	On a database restore, one or more options do not match.	None – SFC tried to restore as much of database as possible.
-	-	STATUS TAG ID. UNKNOWN	-	Selection is unknown.	Be sure SFC software is latest version.
-	-	TAG NO. LOW LOOP RES	-	Not enough resistance in series with communication loop.	Check sensing resistor and increase resistance to at least 250Ω.
-	-	TAG NO. SFC FAULT	-	SFC is operating incorrectly.	Try communicating again. If error still exists, replace SFC.
-	-	URV 1 . TAG ID. >RANGE "H20_39F	-	SFC – Value calculation is greater than display range. SCT – The entered value is not within the valid range.	SFC – Press [CLR] key and start again. Be sure special units conversion factor is not greater than display range. SCT – Enter a value within the range.

Section 12 —Parts List

12.1 Replacement Parts

Part Identification

- All individually salable parts are indicated in each figure by key number callout. For example, 1, 2, 3, and so on.
- All parts that are supplied in kits are indicated in each Figure by key number callout with the letter “K” prefix. For example, K1, K2, K3, and so on.
- Parts denoted with a “†” are recommended spares. See Table 39 for summary list of recommended spare parts.

Figure 29 shows major parts for given model with parts list Figure reference

Continued on next page

12.1 Replacement Parts, Continued

Figure 29 Major SMV 3000 Smart Multivariable Transmitter Parts Reference.

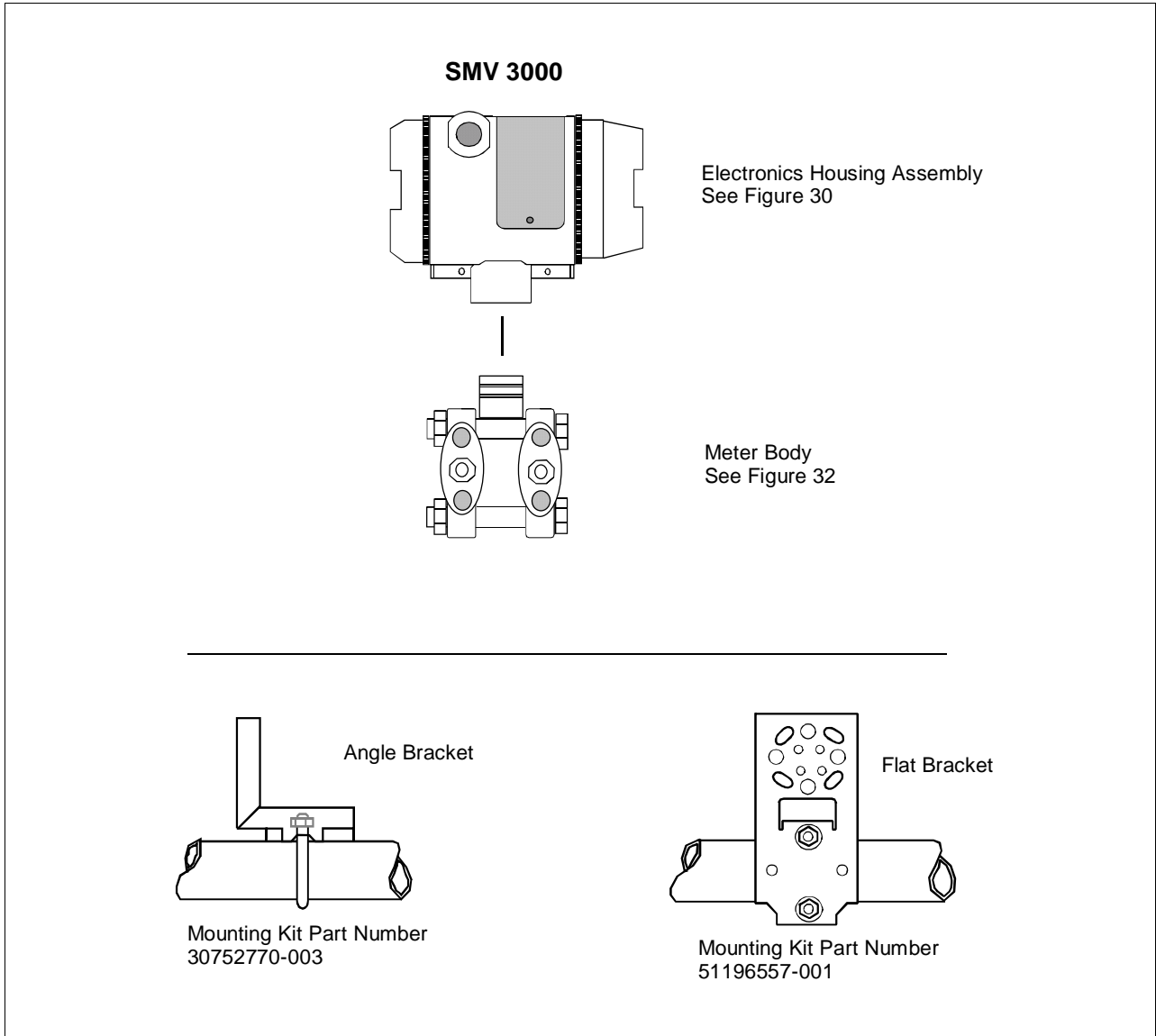

Continued on next page

12.1 Replacement Parts, Continued

Figure 30 SMV 3000 Electronics Housing

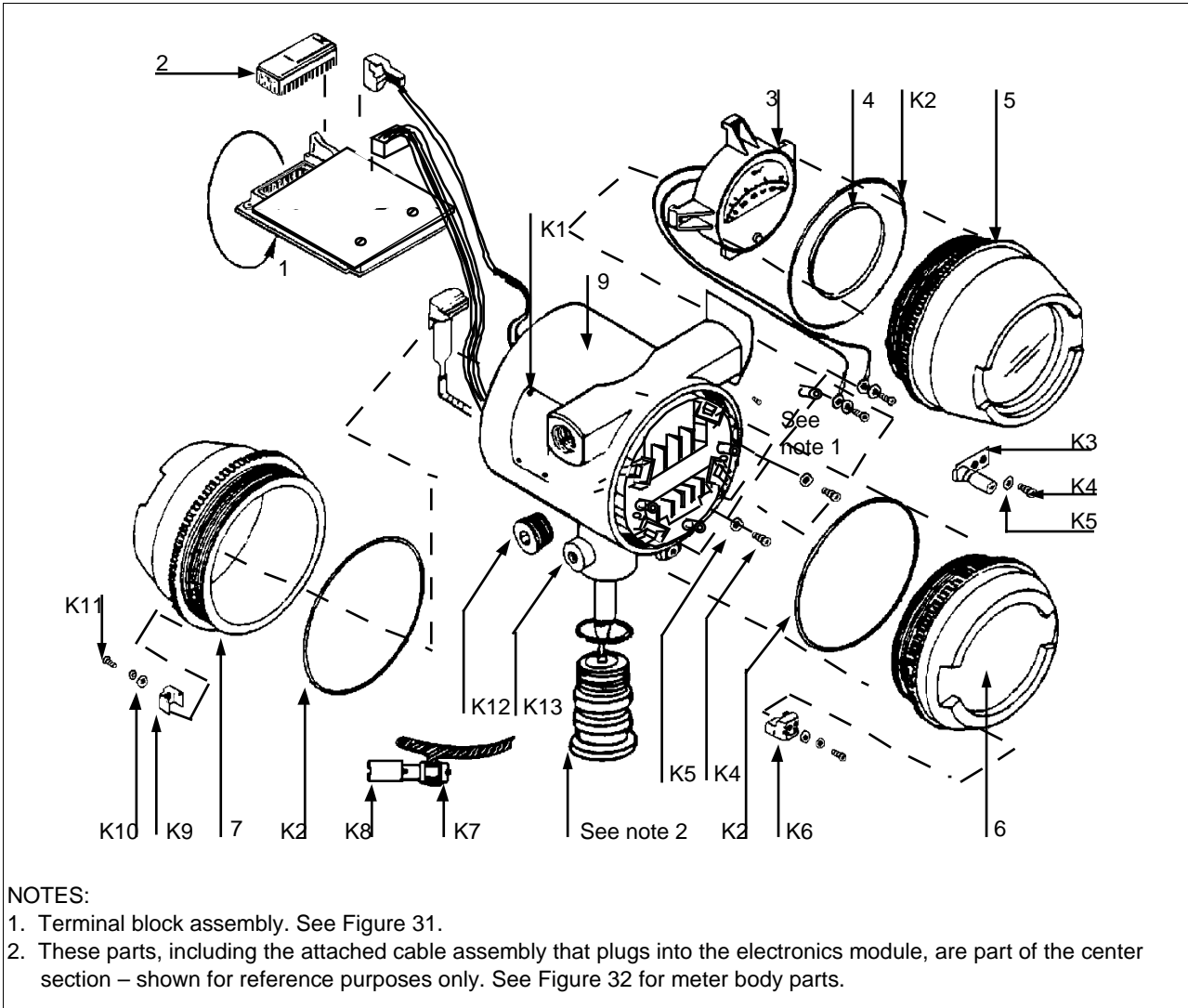

NOTES:

1. Terminal block assembly. See Figure 31.
2. These parts, including the attached cable assembly that plugs into the electronics module, are part of the center section – shown for reference purposes only. See Figure 32 for meter body parts.

Continued on next page

12.1 Replacement Parts, Continued

Table 36 Parts Identification for Callouts in Figure 30

Key No.	Part Number	Description	Quantity Per Unit
1	51404208-503†	Electronics module assembly	1
2	51197486-501	PROM assembly	1
	ATTENTION	Specify transmitter serial number or 10 digit PROM number along with part number when ordering. You can get the serial number or the PROM number from the nameplate on the meter body or by using the SCT or SFC.	
3		Output meter	1
	30752118-501	Analog meter (Table III selection ME)	
4	30753854-001	Gasket, retainer	1
5	30755956-501	Cap assembly, meter (Table III selection ME)	1
6	30752006-501	Cap, terminal	1
7	30752008-501	Cap, electronics	1
8	30753997-001	Retainer, molding	1
9	30752557-507	Housing, electronics without lightning protection	
	30752557-508	Housing, electronics with lightning protection	1

Continued on next page

12.1 Replacement Parts, Continued

Table 36 Parts Identification for Callouts in Figure 30, Continued

Key No.	Part Number	Description	Quantity Per Kit
	30753392-001†	Accessory O-ring kit	
K2		O-ring housing	6
	30753783-001	Lock assembly kit, electronics terminal or meter cap (PTB)	
K5		Lockwasher, metric, M4	12
K6		Lock, cover	12
K10		Flat washer, metric, M4	12
K11		Screw, socket head, metric, M4, 20 mm long	12
	30753783-001	Lock assembly kit, electronics cap	
K5		Lockwasher, metric, M4	12
K9		Lock, cover	6
K10		Flat washer, metric, M4	6
K11		Screw, socket head, metric, M4, 20 mm long	6
	30753804-001	Ground terminal assembly kit	
K3		Terminal strip, grounding	3
K4		Screw, pan head, metric, M4, 6 mm long	6
K5		Lockwasher, metric, M4	12
K7		Terminal, external	6
K8		Screw, pan head, metric, M4, 10 mm long	6
K14		Terminal washer (Not Shown)	3
	30753784-001	Miscellaneous hardware kit	
K1		Tapping screw, number 4, 4.75 mm lg	24
K4		Screw, pan head, metric, M4, 6 mm long	24
K5		Lockwasher, metric, M4	12
K12		Pipe plug, socket type	6
K13		Set screw, metric, M8, 18 mm long	6

Continued on next page

12.1 Replacement Parts, Continued

Figure 31 SMV 3000 Terminal Block Assembly

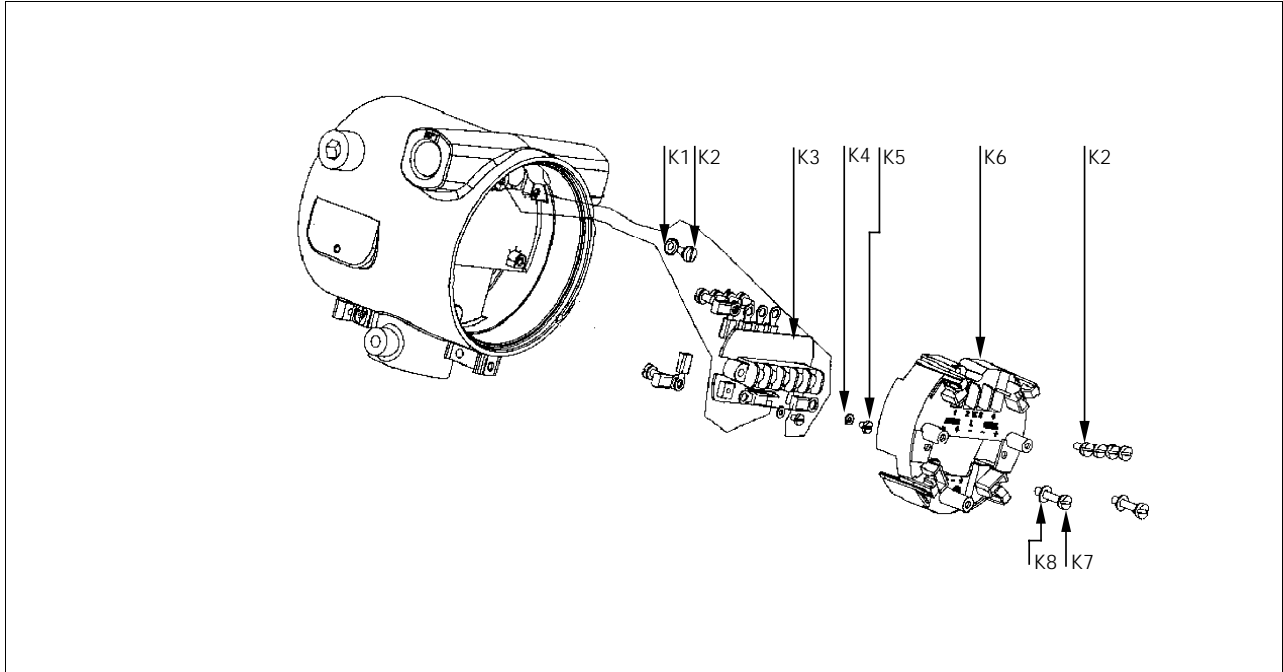

Table 37 Parts Identification for Callouts in Figure 31

Key No.	Part Number	Description	Quantity Per Kit
	51197487-001	Terminal block assembly kit (black, without lightning protection)	
	51197487-002	Terminal block assembly kit (red, with lightning protection)	
K1		Terminal washer	1
K2		Screw, metric, M4	10
K3		Terminal assembly (without lightning protection)	
		Terminal assembly (with lightning protection)	1
K4		Lockwasher, split, 3mm	2
K5		Screw, 3mm by 4mm long	2
K6		Terminal block cover (black, without lightning protection)	
		Terminal block cover (red, with lightning protection)	1
K7		Screw, metric, M4	2
K8		Washer	2

Continued on next page

12.1 Replacement Parts, Continued

Figure 32 SMV 3000 Meter Body

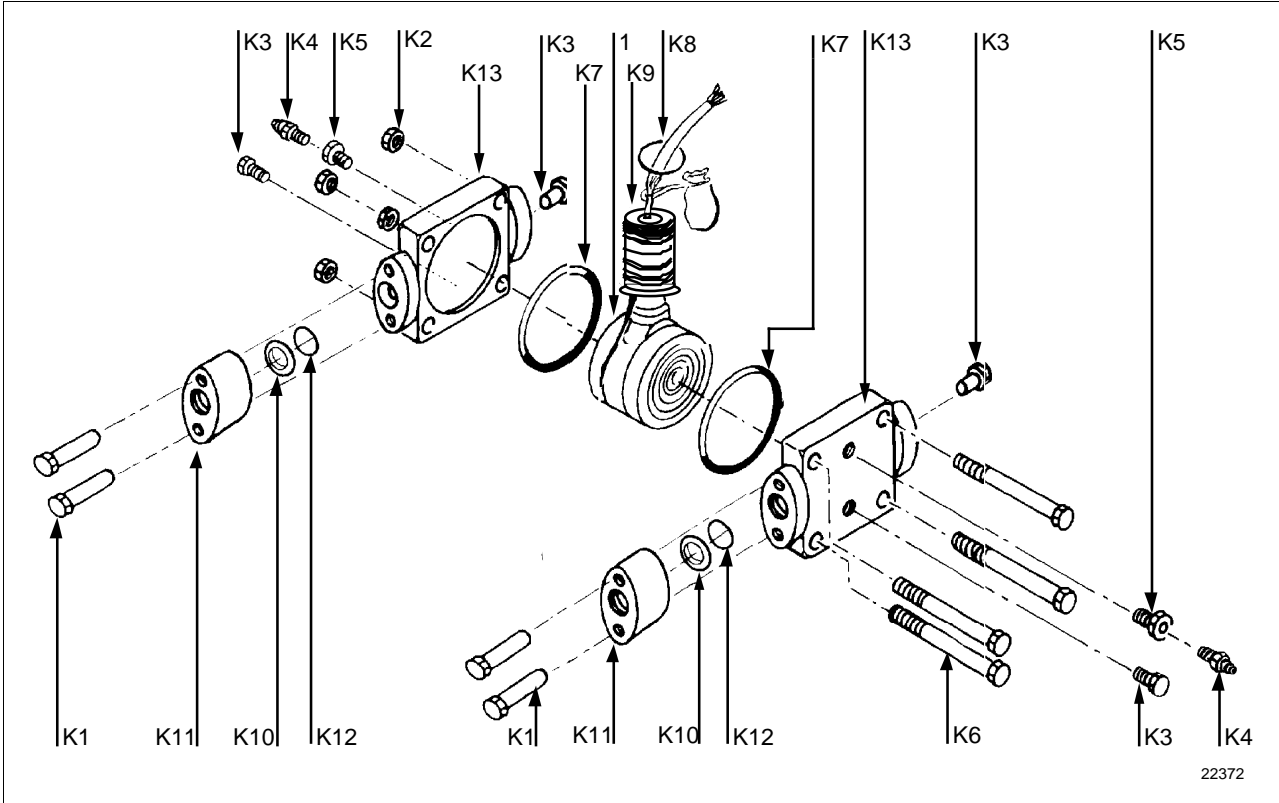

Table 38 Parts Identification for Callouts in Figure 32

Key No.	Part Number	Description	Quantity Per Unit
1		Center section	1
	30753790-001	Carbon steel bolts and nuts kit	
K1		Bolt, hex head, 7/16-20 UNF, 1.375 inches lg., flange adapter	4
K2		Nut, hex, metric, M12, process heads	4
K6		Bolt, hex head, metric, M12, 90mm lg., process heads	4
	30753791-002	A286 SS (NACE) bolts and 302/304 SS (NACE) nuts kit	
K1		Bolt, hex head, 7/16-20 UNF, 1.375 inches lg., flange adapter	4
K2		Nut, hex, metric, M12, process heads	4
K6		Bolt, hex head, metric, M12, 90mm lg., process heads	4
	30753785-001	St. steel vent/drain and plug kit	
K3		Pipe plug	4
K4		Vent plug	2
K5		Vent bushing	2

Continued on next page

12.1 Replacement Parts, Continued

Table 38 Parts Identification for Callouts in Figure 32, Continued

Key No.	Part Number	Description	Quantity Per Unit
	30753787-001	Monel vent/drain and plug kit	
K3		Pipe plug	4
K4		Vent plug	2
K5		Vent bushing	2
	30753786-001	Hastelloy C vent/drain and plug kit	
K3		Pipe plug	4
K4		Vent plug	2
K5		Vent bushing	2
	30753788-003†	Process head gasket kit (PTFE material)	
	30753788-004†	Process head gasket kit (Viton material)	
K7		Gasket [for gasket only: 30756445-501 (PTFE) or 30749274-501 (Viton)]	6
K8		O-ring	3
K9		Seal	3
K10		Gasket, flange adapter (for gasket only: 30679622-501)	6
K14	30757503-001	Enclosure seals	2
Flange Adapter Kits (two heads)			
	30754419-002	Flange adapter kit (st. steel flange adapters with carbon steel bolts)	
	30754419-004	Flange adapter kit (monel flange adapters with carbon steel bolts)	
	30754419-018	Flange adapter kit (st. steel flange adapters with 316 st. steel bolts)	
	30754419-020	Flange adapter kit (monel flange adapters with 316 st. steel bolts)	
K1		Bolt, hex head, 7/16-20 UNF, 1.375 inches lg., flange adapter	4
K10		Gasket, flange adapter	2
K11		Flange adapter	2
K12		Filter screen	2
	30754419-003	Flange adapter kit (hastelloy C flange adapters with carbon steel bolts)	
	30754419-019	Flange adapter kit (hastelloy C flange adapters with 316 st. steel bolts)	
K1		Bolt, hex head, 7/16-20 UNF, 1.375 inches lg., flange adapter	4
K10		Gasket, flange adapter	2
K11		Flange adapter	2

Continued on next page

12.1 Replacement Parts, Continued

Table 38 Parts Identification for Callouts in Figure 32, Continued

Key No.	Part Number	Description	Quantity Per Unit
Process Head Kits (one head with PTFE head gasket)			
	30753908-001	Process head assembly kit (hastelloy C head)	
	30753908-002	Process head assembly kit (hastelloy C DIN head)	
	30753908-003	Process head assembly kit (carbon steel head with side vent/drain)	
	30753908-004	Process head assembly kit (st. steel head with side vent/drain)	
	30753908-005	Process head assembly kit (monel head)	
	30753908-009	Process head assembly kit (carbon steel head without side vent/drain)	
	30753908-010	Process head assembly kit (stainless steel head without side vent/drain)	
	30753908-011	Process head assembly kit (stainless steel DIN head without side vent/drain)	
K3		Pipe plug	2
K4		Vent plug	1
K5		Vent bushing	1
K7		Gasket (PTFE), process head	1
K10		Gasket (PTFE), flange adapter	1
K13		Process head	1
Process Head Kits (one head with Viton head gasket)			
	30753908-101	Process head assembly kit (hastelloy C head)	
	30753908-102	Process head assembly kit (hastelloy C DIN head)	
	30753908-103	Process head assembly kit (carbon steel head with side vent/drain)	
	30753908-104	Process head assembly kit (st. steel head with side vent/drain)	
	30753908-105	Process head assembly kit (monel head)	
	30753908-109	Process head assembly kit (carbon steel head without side vent/drain)	
	30753908-110	Process head assembly kit (stainless steel head without side vent/drain)	
	30753908-111	Process head assembly kit (stainless steel DIN head without side vent/drain)	
K3		Pipe plug	2
K4		Vent plug	1
K5		Vent bushing	1
K7		Gasket (Viton), process head	1
K10		Gasket (PTFE), flange adapter	1
K13		Process head	1

Continued on next page

12.1 Replacement Parts, Continued

Table 39 Summary of Recommended Spare Parts

Part Number	Description	Reference		Spares for		
		Figure Number	Key Number	1-10 Units	10-100 Units	100-1000 Units
51404208-503	Electronics module assembly	30	1	1	1 - 2	2 - 4
30753392-001	Accessory O-ring kit	30	K2	1	1 - 2	2 - 4
51197487-001	Terminal block assembly kit (black – without lightning protection)	31	K1 - K8	1	1	1 - 2
51197487-002	Terminal block assembly kit (red – with lightning protection)	31	K1 - K8	1	1	1 - 2
30753788-003 30753788-004	Process head gasket kit Teflon Viton	32	K7 - K10	1	1 - 4	4 - 10
Meter Body *						
Specify complete model number from nameplate	Absolute Pressure models (SMA110, SMA125) Gauge Pressure models (SMG170)	32		1 *	1 - 2 *	2 - 4 *

* For spare meter bodies, we recommend that you keep a complete transmitter assembly as a spare unit.

Section 13 —Reference Drawings

13.1 Wiring Diagrams and Installation Drawings

Wiring Diagrams

These wiring diagrams are included in numerical order behind this page for wiring reference.

SMV 3000	Wiring Diagrams for . . .	See Drawing Number . . .
Multivariable Transmitter	Intrinsically safe installations, covering wiring of: <ul style="list-style-type: none"> - Temperature sensor - Remote meter - Remote analog meter - Smart meter 	51404251
	Non-intrinsically safe installations	51404252
	Remote analog meter wiring in non-intrinsically safe installations.	51404250

Installation Drawings

The following table lists available installation drawings for reference. If you need a copy of a drawing, please determine the appropriate drawing number from the following table and contact your Honeywell representative to obtain a copy.

For Mounting Transmitter on a . . .	Using Mounting Bracket Type . . .	See Drawing Number . . .
Vertical pipe	Angle	30753719-000
Horizontal pipe	Angle	30753721-000
Vertical pipe	Flat	51404008-000
Horizontal pipe	Flat	51404009-000

Appendix A – PM/APM/HPM SMV 3000 Integration

A.1 Overview

Appendix Contents

This appendix includes these topics:

Topic	See Page
A.1 Overview	149
A.2 Description	150
A.3 Data Exchange Functions	152
A.4 Installation	157
A.5 Configuration.....	159
A.6 Operation Notes	164

Purpose of this appendix

This appendix provides an introduction to PM/APM/HPM SMV 3000 Integration as a supplement to general information in the *PM/APM Smartline Transmitter Integration Manual*.

Reader assumptions

- You are familiar with TDC 3000^X system components and have a TDC 3000^X bookset on hand.
 - You have a copy of *PM/APM Smartline Transmitter Integration Manual* on hand.
-

A.2 Description

Definition

PM/APM/HPM SMV 3000 Integration is a term used to describe the coupling of an SMV 3000 Smart Multivariable Transmitter to a TDC 3000^X Process Manager (PM), Advanced Process Manager (APM), or High Performance Process Manager (HPM) through a digital communications link.

This integration lets operators access SMV 3000 operation and configuration data through Universal Station (US) displays as well as the Smartline Configuration Toolkit (SCT 3000) and the Smart Field Communicator (SFC) (not recommended) .

Communications Link

The communications link consists of the standard two wire output used for 4 to 20 milliampere transmission in common analog measurement operations. It is transformed into the path for digital data exchange when the SMV 3000 transmitter is configured for DE mode operation. In the DE mode, the transmitter continuously broadcasts data in a 6-byte format as defined through configuration. The 6-byte format is the only selection for SMV 3000 communications. See Section 3.2 in the *PM/APM Smartline Transmitter Integration Manual* for DE format details.

Each link connects an SMV 3000 through a Field Termination Assembly (FTA) to a Smart Transmitter Interface MultiVariable (STIMV) Input/Output Processor (IOP) in a Process Manager or an Advanced Process Manager. Each STIMV IOP handles up to 16 inputs (or points) from Smartline transmitters operating in the DE mode. Note that the STIMV IOP is also referred to as the Smart Transmitter Interface Module (STIM).

Compatibility

The PM/APM/HPM SMV 3000 Integration is compatible with TDC 3000^X control systems that have software release R230 or above and are equipped with the multivariable transmitter versions of the STIM model number

MU-PSTX03.

Continued on next page

A.2 Description, Continued

Diagram: Typical Integration Hierarchy

Figure A-1 shows a typical PM/APM/HPM SMV 3000 integration hierarchy with the transmitter connected to the system through an STI FTA, and a multivariable STIMV IOP in the PM/APM/HPM.

Figure A-1 Typical PM/APM/HPM SMV 3000 Integration Hierarchy.

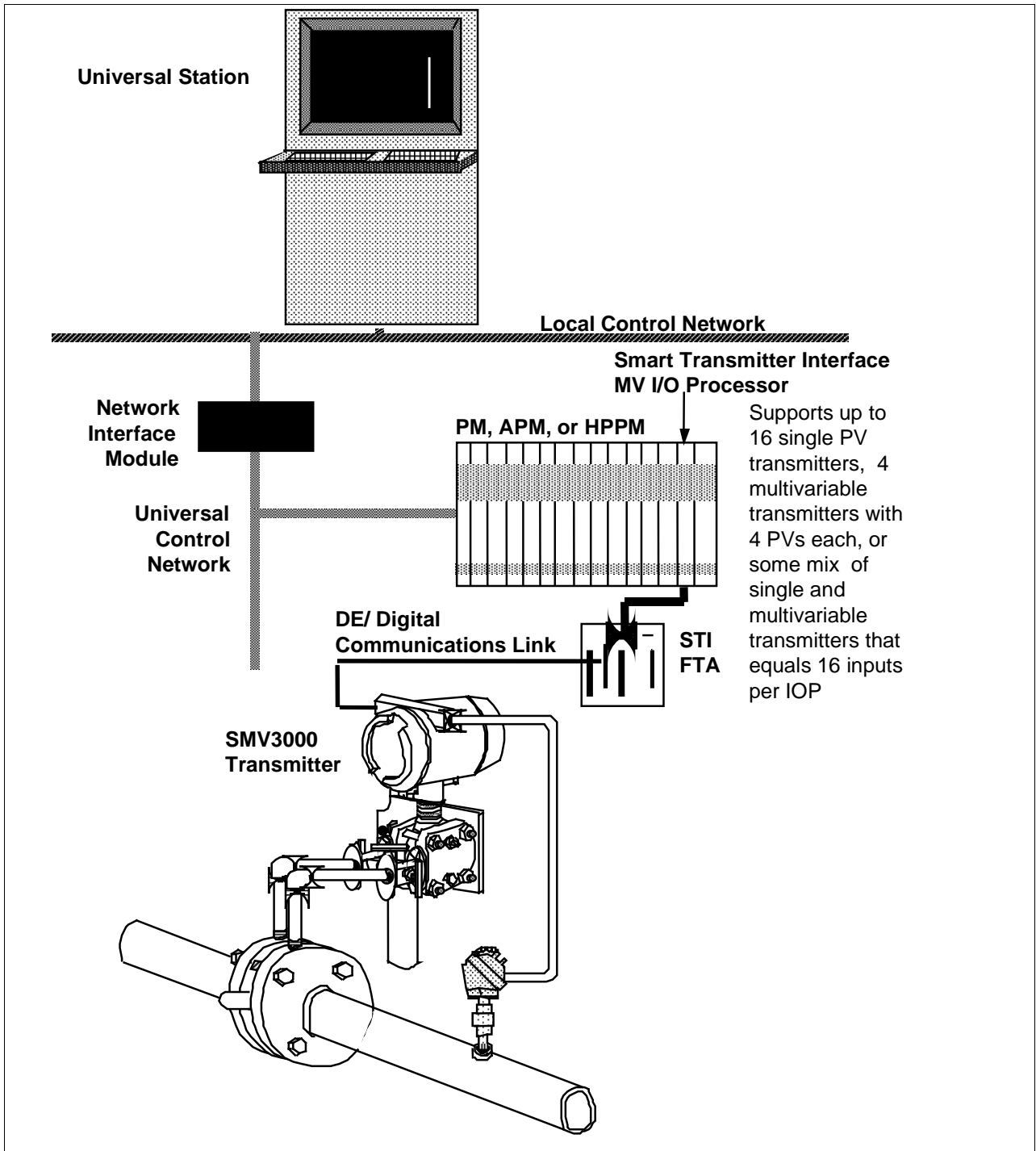

A.3 Data Exchange Functions

Introduction

The exchange of data over the bi-directional data path between the SMV 3000 transmitter and the PM/APM/HPM is based on imaging SMV 3000 data through the use of Analog Input (AI) point parameters in the STIMV IOP for each transmitter PV. This is done by mapping parameters from the transmitter to the IOP, and from the IOP to the transmitter as shown in Figure A-2.

While the mapped parameters are predefined in the IOP firmware, the actual data exchange functions will depend on entries made during STIMV IOP point building and transmitter PV selections made while configuring the transmitter database through the SCT 3000

This section discusses various functions that affect how the data is exchanged. Most of this information is for reference only, but some will be helpful when making point building decisions. Refer to section 6 in the *PM/APM Smartline Transmitter Integration Manual* for details about STIMV IOP point building.

Figure A-2 Mapped Parameters are Basis for Data Exchange

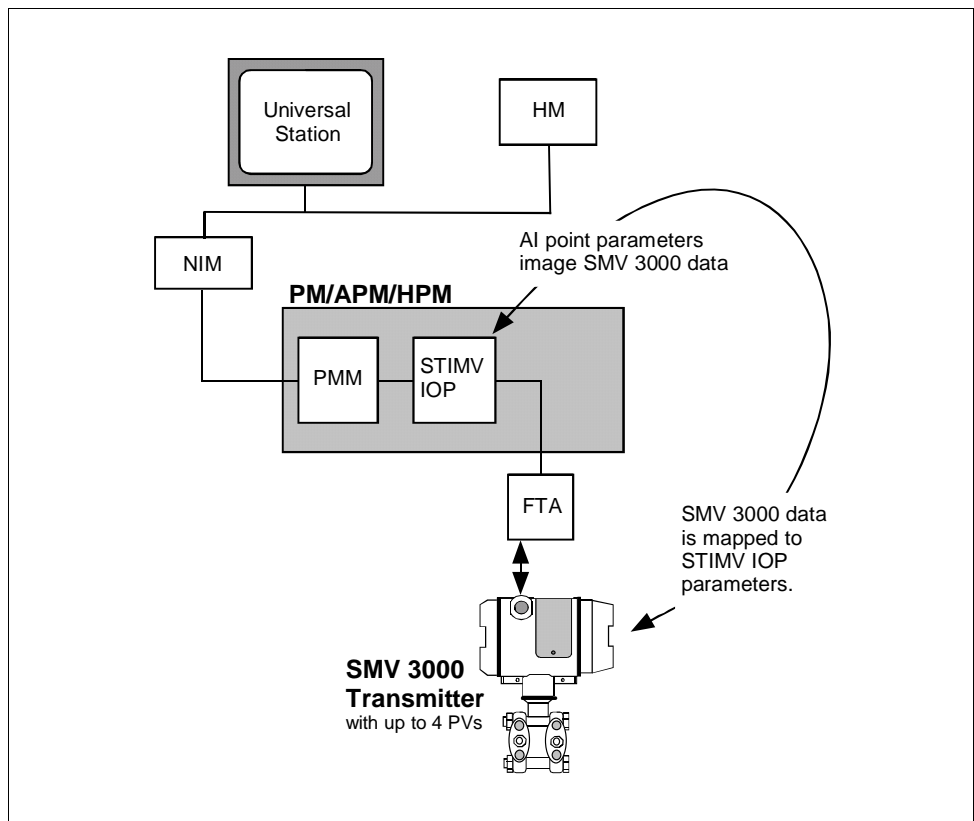

Continued on next page

A.3 Data Exchange Functions, Continued

16 Points per STIMV IOP

The STIMV IOP contains sixteen AI points which are read/write accessible from the PMM and upper network components as shown in Figure A-3. Figure A-3 shows four SMV 3000 transmitters with four PVs each connected to IOP points 1, 5, 9 and 13, respectively.

You can mix single PV transmitters with multivariable transmitters within the given one to eight or nine to sixteen IOP boundary, but all PVs for a multivariable transmitter must be allotted to consecutive slots within a given IOP boundary. While a multivariable transmitter is physically connected to only one slot, the adjacent slots are allocated for the other PVs of the transmitter and they can not cross over or wrap around the IOP boundaries.

Note that points include the usual IOP PV processing parameters such as alarm limits, alarm hysteresis, PV clamping, and engineering unit conversion

Figure A-3 Sixteen AI Points per STIMV IOP

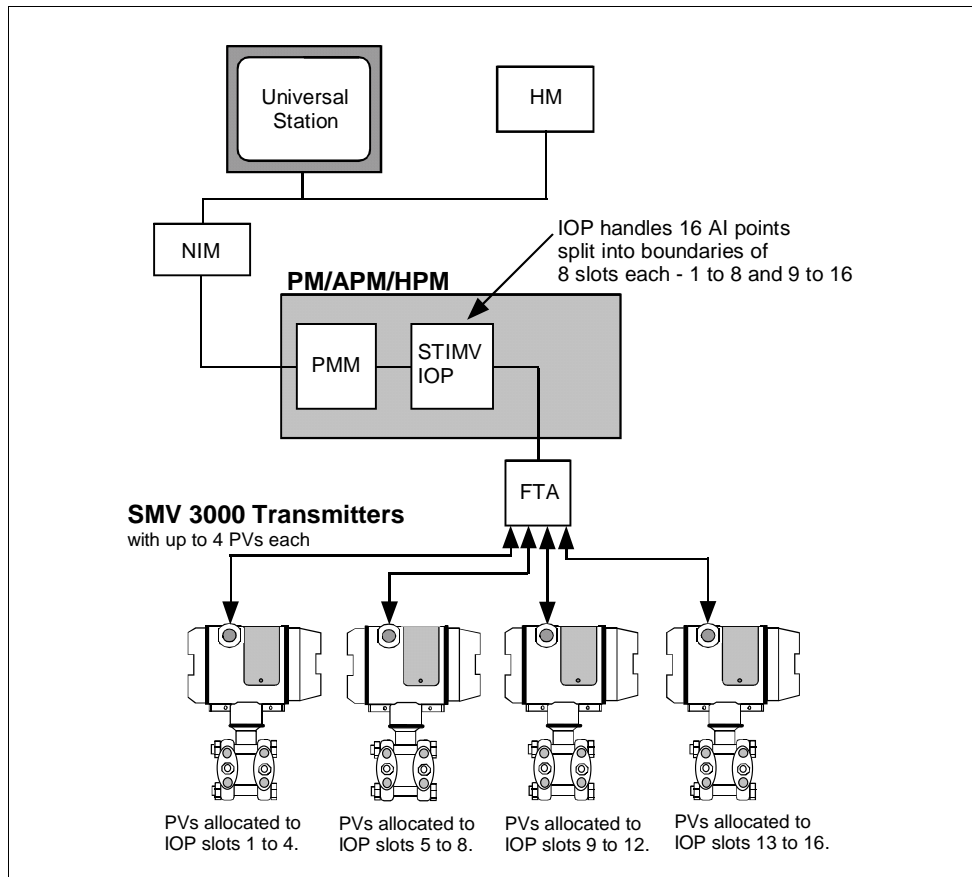

Continued on next page

A.3 Data Exchange Functions, Continued

Four Points Per Transmitter

To accommodate all the PVs that can be associated with a given SMV 3000 transmitter, you must build an AI point for each PV up to a maximum of four points (PVs) per transmitter. Each point built must have the same name assigned for the STITAG parameter and be assigned to contiguous slots. The IOP will calculate the number of PVs based on the number of identical contiguous STITAG parameters and allocate the appropriate number of logical slots in addition to the master slot.

The master slot represents the slot to which the transmitter is physically connected and is identified as PV number 1. It is the lowest numbered slot in a group of contiguous slots with identical STITAG names. The PV numbers are assigned consecutively for the associated logical slots as 2, 3, and 4. As shown in Figure A-4, a transmitter configured for 4 PVs and connected to the terminals for slot 5 on the IOP will have PV numbers 1, 2, 3, and 4 assigned for PVs associated with physical (master) and logical slots 5, 6, 7, and 8, respectively.

Since the master slot as well as all associated logical slots are built as separate AI points, each slot/PV has its own configuration parameters and functions like a separate transmitter database. This means you can modify individual parameters for a given PV independent of other PVs. However, changes in common parameters like STITAG will also affect the other PVs.

Figure A-4 AI Point for Each Transmitter Input

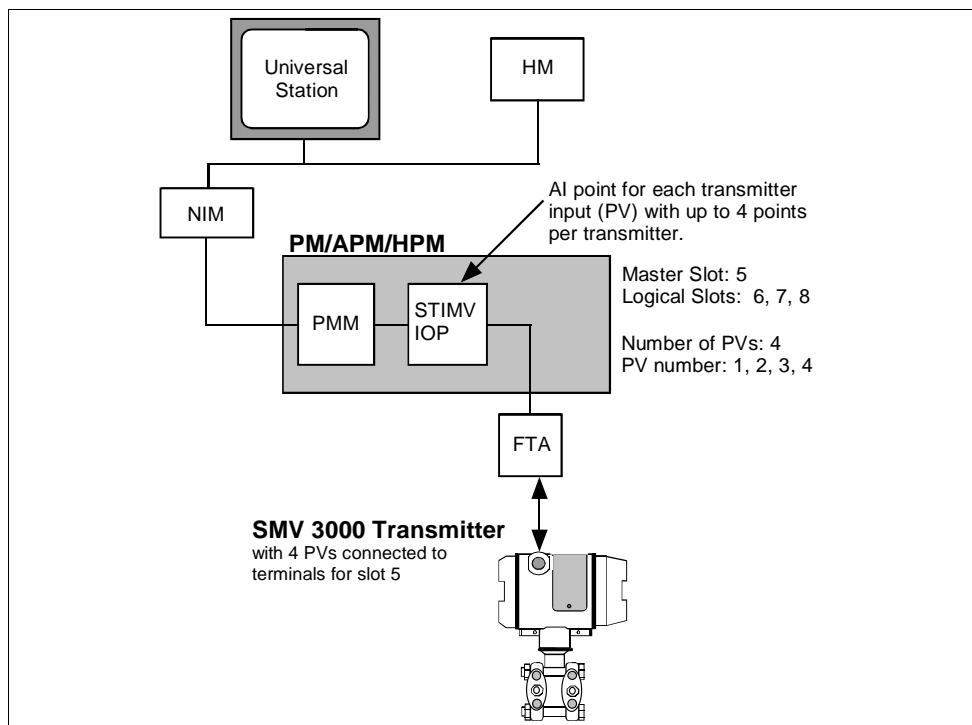

Continued on next page

A.3 Data Exchange Functions, Continued

About Number Of PVs The number of PVs that a given SMV 3000 transmitter supports is determined upon its database configuration. Using the SCT 3000, SFC or through the universal station, the SMV can be configured to select (or turn ON) any number of PVs for broadcast to the IOP. The PV1 input is always selected for broadcast but you can configure it to also include secondary variable data. You can select PV2, PV3, and PV4 for broadcast (by turning them ON or OFF) as applicable for the given measurement application. Table A-1 shows what PVs represent in the SMV 3000 transmitter. See PV Type in subsection 6.5 for details in selecting PVs for broadcast using the SCT 3000.

See DE_CONF parameter in subsection A.5 and DE_CONF Changes in subsection A.6 for more information on selecting PVs using the universal station.

Table A-1 Summary of SMV 3000 Transmitter PVs Configuration

SMV PV Number	Value represented
PV1 (DP)	Differential pressure input.
PV1 (DP) w/SV1 (M.B.Temp)	Differential pressure input and separate secondary variable (meter body temperature).
PV2 (SP)	Static pressure input (May be GP or AP depending upon transmitter type.)
PV3 (TEMP)	Process temperature input
PV4 (FLOW)	Calculated rate of flow

Continued on next page

A.3 Data Exchange Functions, Continued

About Database Broadcast

Table A-2 lists the maximum database size and transmission time for the SMV 3000. The actual time may be less, if less options are configured. See Section 3 in the *PM/APM Smartline Transmitter Integration Manual* for other DE protocol data. Remember that transmitters only broadcast bytes of their database in the DE 6-byte format. Note that the absolute maximum time for any Smartline transmitter to broadcast its database is 94 seconds.

Table A-2 Typical SMV 3000 Database Size and Broadcast Time

Transmitter Type	Database (Bytes)	Time (Seconds)
SMV 3000	202	74

About BAD Database Protection

It is possible to get an undetected database mismatch for PV4 algorithm configuration parameters that are not mapped to the IOP. This means the potential exists for the control loop to use a bad database that will not be flagged by a bad PV signal.

The PV4 algorithm parameters must be configured through the SCT 3000 and are not mapped to the IOP. Thus, it would be possible to replace a transmitter that is operating with the ideal gas volume flow equation with one configured for the ideal gas mass flow equation without causing a bad PV indication but resulting in different PV4 data. See subsection A.5 for additional information about configuring the SMV and TDC.

The calculation of PV4 is also based on equation compensation, units, pressure, temperature, and scaling factor entries that must be configured through the SCT 3000 and are not mapped to the IOP. The scaling factor value could be changed without causing a bad PV indication but resulting in a different PV4 rate of flow calculation.

Note that full database protection is provided for the other SMV 3000 transmitter PVs, since their configuration parameters are mapped to the IOP.

A.4 Installation

Mounting Assumptions

We assume that you have physically mounted the integration components in accordance with appropriate instructions in this manual and the TDC 3000^X bookset.

WARNING

Before you make any wiring connections, use the SCT to set the PV Type to PV1 for transmitters operating in DE mode; or if the transmitter is in the analog mode, use the SCT 3000 set the Analog Output Selection to PV1 and select Analog as the communication mode. Otherwise, multiple PVs could conflict with other slots causing contention problems and bad PV indications.

Wiring Connections

You wire the SMV 3000 transmitter for integration the way you would any other Smartline transmitter. See Section 5 in the *PM/APM Smartline Transmitter Integration Manual* for details.

Connection Rule

If the SMV 3000 transmitter will provide multiple inputs (PVs), the FTA screw terminals used for the transmitter's DE output connection identify the physical (or master) slot for the transmitter's PVs. In this case, be sure

- No other Smartline transmitters are connected to consecutive FTA screw terminals that are allotted as logical slots for the transmitter's other PVs.
 - Consecutive logical slots allotted for the transmitter's other PVs do not cross over IOP boundaries from 8 to 9 or wrap around an IOP boundary from 8 to 1 or 16 to 9.
-

Continued on next page

A.4 Installation, Continued

Connection Rule, continued

Figure A-5 shows an example of connection rule violations which include connecting an ST 3000 transmitter to an allocated logical slot and an SMV 3000 transmitter to a slot that causes a logical slot to wrap around the IOP boundary. Note that the FTA shown in Figure A-5 is a non-redundant type and the connection designations, styles, and locations will vary for redundant type FTAs. See Section 5 in the *PM/APM Smartline Transmitter Integration Manual* for typical redundant FTA connection details.

Figure A-5 Connection Rule Example.

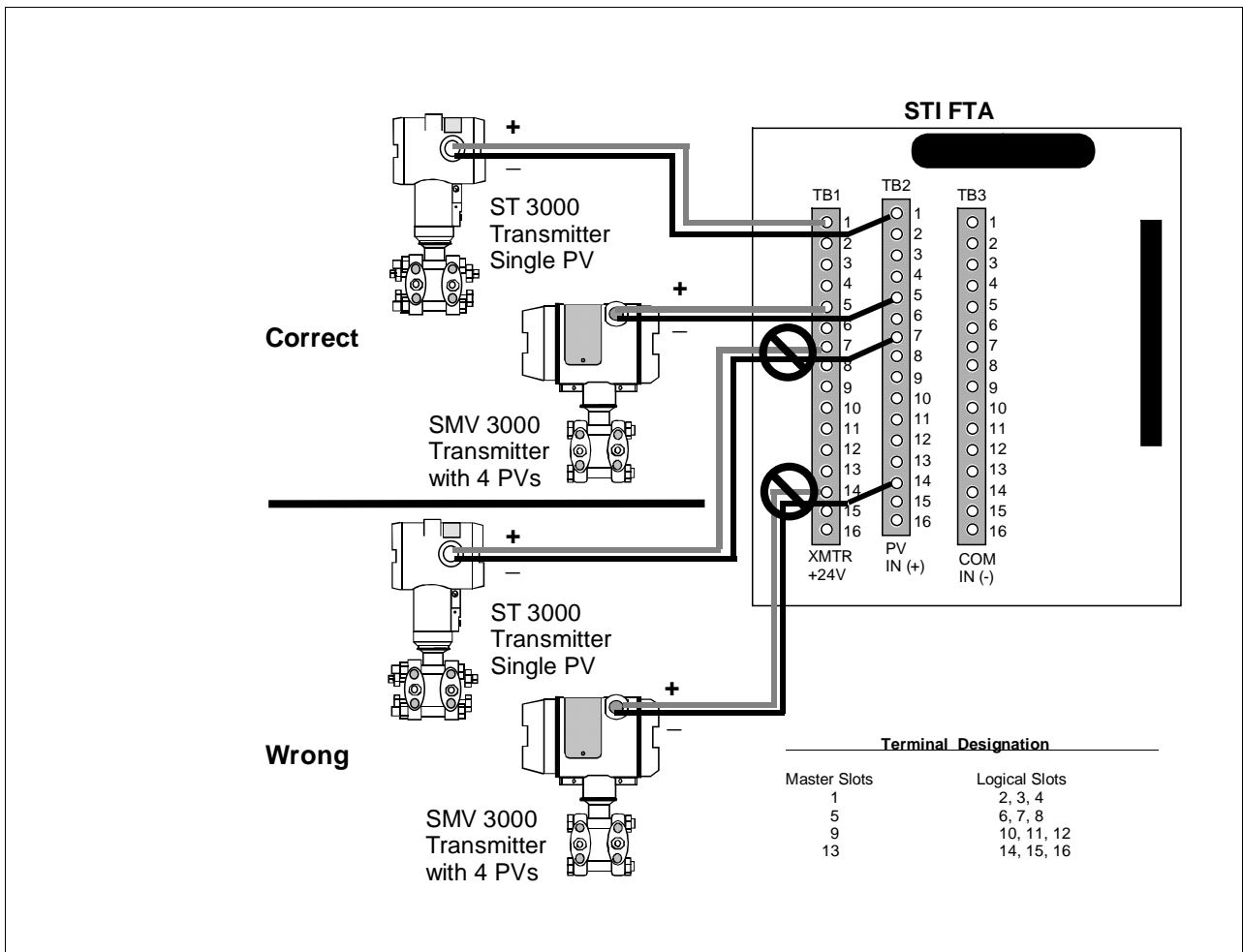

A.5 Configuration

About Configuration

You can configure all of the SMV 3000 parameters by using the SCT 3000 as outlined in this manual. You can also configure most of the SMV 3000 parameters through displays at the Universal Station, but PV4 algorithm parameters are only configurable through the SCT 3000.

However, to set up the TDC 3000^X system for integration operation, you must build points for each transmitter PV at the Universal Station.

Getting Started

First use the SCT 3000 to completely configure the SMV 3000 and also set the SMV transmitter in DE mode with the PV Type parameter set for PV1 ON only. This assures that you configure any applicable PV functions and define the transmitter as a single PV1 for initial IOP point building to minimize the chance of any slot conflicts and possible interruption of valid data.

Building Points

The general procedure for building STIMV IOP points is covered in Section 6 of the *PM/APM Smartline Transmitter Integration Manual*. Use this procedure to build and load an Analog Input point for each SMV 3000 transmitter PV. Supplement the Parameter Entry Display (PED) selection information with the SMV 3000 specific data in this section.

ATTENTION

We assume that:

- You know how to interact with the TDC 3000^X system using the Universal Station touch screens and keyboard. If you do not know, refer to the *Process Operations Manual* for details.
 - You are familiar with the “point” building concept for the PM/APM/HPM and the UCN and LCN networking schemes. If you are not familiar, refer to the *Data Entity Builder Manual* for information.
-

Point Building Rules

- Enter identical STITAG name for each PV from a given SMV 3000 transmitter up to a maximum of 4. If you enter five identical STITAG names, the fifth will be identified as the master or physical slot for another transmitter.
 - You must use DE CONF selection for 6-Byte format for SMV 3000 transmitters, (parameters PV_DB or PV_SV_DB).
 - Select the SENSRTYP parameter that is appropriate for a given SMV 3000 transmitter PV. See Table A4 on next page.
-

Continued on next page

A.5 Configuration, Continued

PED Entries

Each PED parameter is defined in Appendix A of the *PM/APM Smartline Transmitter Integration Manual*. While most entries are generic for all Smartline transmitters, some entries require additional transmitter specific data for reference. Review the following paragraphs for SMV 3000 specific data to supplement the given parameter definition. The parameters are presented in the order in which they are encountered in the PED pages.

EUDESC Parameter

Enter the engineering unit description for each PV of the SMV 3000 that you want the universal station to show for the given PV. (Normally, these units will be the same as the units entered in the STI_EU parameter, which is described on the next page.) Please note that for PV4, if rate of flow calculation is volume flow in cubic meters per hour enter “CM_HR.” For PV4 flow in any other units enter the engineering unit description, but then you must provide additional values so that the PV is reranged to show PV4 in the selected units. See subsection A.6 “PV Engineering Units Conversions” for more information.

Table A-3 lists the base (default) engineering units for the SMV 3000. Note that degrees Celsius is default engineering units for the secondary variable.

Table A-3 Base Engineering Units for SMV 3000 Transmitter PVs

IF Process Variable Number is...	THEN base engineering unit is ...
PV1	inH2O@39 °F
PV2	inH2O@39 °F
PV3	°C
PV4	m ³ /h for volume flow, or tonnes/h for mass flow

STITAG Parameter

Besides serving as a transmitter identification name, the IOP uses the number of identical STITAG names to calculate the number of PVs associated with a given transmitter. An STITAG name must be entered for all SMV 3000 transmitter PVs.

Continued on next page

A.5 Configuration, Continued

SENSRTYP Parameter The default sensor type for a given SMV 3000 transmitter PV is listed in Table A-4.

Table A-4 Sensor Type Selections for SMV 3000 PVs

IF Process Variable Number is...	THEN SENSRTYP is ...
PV1	SPT_DP
PV2	SPT_AP *
PV3	STT
PV4	SFM

* Use SPT_AP if PV2 is measuring absolute pressure or gauge pressure.

ATTENTION

When using an SMV Model SMG170, the SENSRTYP parameter for PV2 may be set to SPT_AP, but will display a gauge pressure value that may be negative.

PVCHAR Parameter The PV characterization selection for each SMV transmitter PV can be as listed in Table A-5.

Table A-5 PV Characterization Selections for SMV 3000 PVs

IF Process Variable Number is...	THEN PVCHAR can be ...
PV1	LINEAR or SQUARE ROOT *
PV2	LINEAR only.
PV3	LINEAR only.
PV4	LINEAR/N/A †

* Does not affect PV4 flow calculation.

† Linear is shown on detail display, but it has no meaning.

STI_EU Parameter Select any valid Engineering Unit (EU) for PV1, PV2, and PV3, so that the values displayed for URL, LRL, URV, and LRV on the Detail Display will be converted to the selected EU. There is no check for mismatch of EUs, since the transmitter sends these values as a percent of Upper Range Limit so the value is the same regardless of EU.

NOTE: You can only select BLANK or CM_HR as EU for PV4. Keep in mind, that the URL, LRL, URV, and LRV are displayed in “base” units of tonnes per hour (t/h) or cubic meters per hour (m³/h) as applicable.

Continued on next page

A.5 Configuration, Continued

ATTENTION

The actual engineering unit values available in a system will depend upon the LCN software release. See Section 10 in the *PM/APM Smartline Transmitter Integration Manual* for release dependent EU details.

DE_CONF Parameter

While the DECONF selections are the same for all transmitters, the corresponding SCT 3000 selections for PV Type may differ. Table A-6 compares the PV Type selections for SMV 3000 with PED DECONF parameter selections for reference.

Table A-6 DECONF and PV Type Parameter Entry Comparison

IF PED DECONF entry is ...	THEN comparable SCT 3000 PV Type entry can be any one of the following ...
PV	Not Applicable for SMV 3000.
PV_SV	Not Applicable for SMV 3000.
PV_DB	PV1, PV1 and PV2, PV1 - PV3, or PV1 - PV4
PV_SV_DB	PV1 w/SV1, PV1 and PV2 w/SV1 PV1 - PV3 w/SV1, or PV1 - PV4 w/SV1

URL Parameter

Table A-7 lists example Upper Range Limits for a given SMV 3000 transmitter PV. Remember that you can enter the desired URL for the PV4 range through the SCT 3000, but URL for PV1, PV2, and PV3 is a read only fixed value (determined by SMV model and process temperature sensor type).

Table A-7 Example URLs for a SMV Transmitter Model SMA125.

IF Process Variable Number is...	THEN URL is ...
PV1	400 inH2O
PV2	750 psia
PV3	850 °C (varies per sensor type)
PV4	configurable

ATTENTION

If you leave the URL parameter blank, you can upload the transmitter database through the detail display commands to resolve the resulting database mismatch error. The URL is always part of the transmitter's database.

Continued on next page

A.5 Configuration, Continued

DAMPING Parameter The damping value is a real number selection from the transmitter range values shown in Table A-8 for a given SMV 3000 transmitter PV.

Table A-8 Damping Range Values for SMV 3000 Transmitter PVs

IF Process Variable Number is...	THEN Damping Value can be ...
PV1 or PV2	0.00, 0.16, 0.32, 0.48, 1.0, 2.0, 4.0, 8.0, 16.0, or 32.0 seconds
PV3	0.00, 0.3, 0.7, 1.5, 3.1, 6.3, 12.7, 25.5, 51.1, or 102.3 seconds
PV4	0.00, 0.5, 1.0, 2.0, 3.0, 4.0, 5.0, 10.0, 50.0, or 100.0 seconds

ATTENTION

The IOP may temporarily convert the entered damping value to a standard damping enumeration until it accesses the transmitter's database.

PIUOTDCF Parameter This parameter represents the sensor fault detection ON/OFF selection for PV3 only.

CJACT Parameter This parameter will apply for PV3 thermocouple input only. It defines whether an internal cold-junction (ON) or an externally provided cold-junction reference (OFF) is to be used.

After Point is Built Once you complete the point build for PV1, you can start building the point for the next PV or go to the Detail display for the point you just built and either upload the transmitter's database to the IOP or download the IOP's transmitter database to the transmitter. See Section A-6 in this Appendix and Section 7 in the *PM/APM Smartline Transmitter Integration Manual* for operation data using the Universal Station.

A.6 Operation Notes

Generic Operations

Most operator actions initiated through Detail displays at the Universal Station are generic for all Smartline transmitters. Refer to Section 7 in the *PM/APM Smartline Transmitter Integration Manual* for details about these generic operations.

This section outlines some differences in operations that are unique to the multivariable STIMV IOP and the SMV 3000 transmitter in particular.

Detail Display Difference

Page 2 of the Detail display for a multivariable STIM point includes an additional field in the lower right hand corner for PV Number and Number of PVs identification as shown in Figure A-6. This lets you quickly identify what PV number you are viewing and how many PVs are associated with this given SMV 3000 transmitter.

Figure A-6 Detail Display with PV Number and Number of PVs Field.

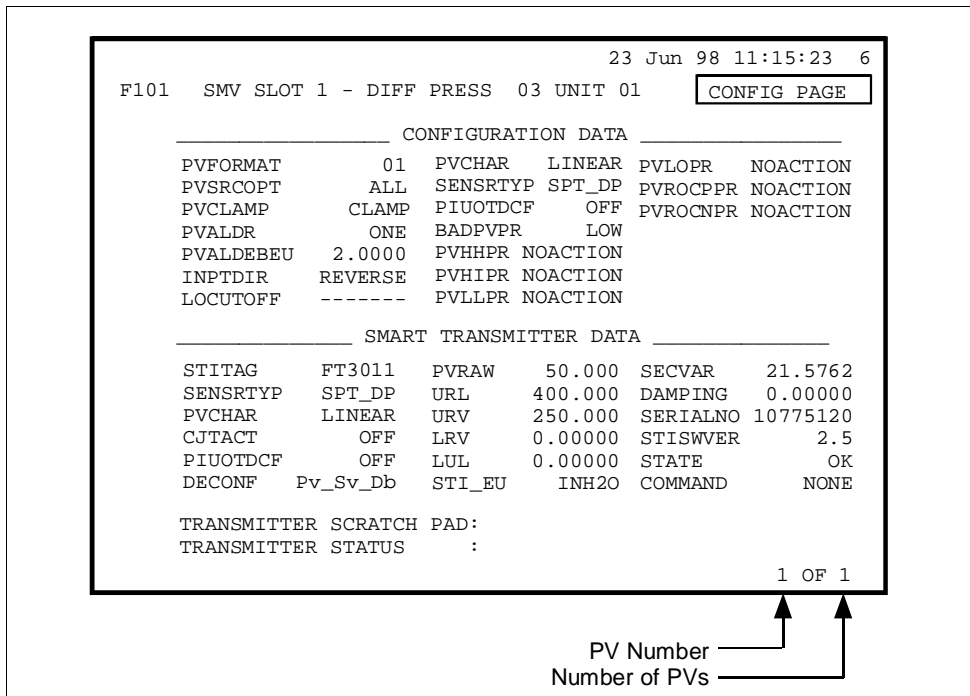

Database Mismatch Parameters

The following parameters are added to the list of parameters that the STIMV IOP checks for database mismatches between itself and the transmitter.

- PV Number
- Number of PVs

Continued on next page

A.6 Operation Notes, Continued

Database Mismatch Parameters, continued

If a mismatch is detected, only the slots (PVs) that have the mismatch will have their PV value set to not a number (NAN) and their STATE parameter on the Detail display will show DBCHANGE. Note that an asterisk "*" will appear next to the PV number or Number of PVs on the other slots to indicate that there is a problem.

DECONF Changes

A change in the DECONF parameter such as turning PV2, 3, or 4 ON, which is equivalent to building a point for the given transmitter PV, can only be downloaded from the Detail display for PV number 1. Enter identical tag names for as many PVs as desired (sequentially, up to 4) and then download from the master slot. If you try to download a DECONF change from the Detail display for PV number 2, 3 or 4, you will get an error message as shown in Figure A-7.

Figure A-7 Example of DECONF Download Error Message.

The screenshot shows a configuration screen for a transmitter. At the top right, it displays the date and time: "23 Jun 98 11:15:23 6". Below this, the transmitter identification is "F101 SMV SLOT 2 - STATIC PRESS 03 UNIT 01". A button labeled "CONFIG PAGE" is visible. The screen is divided into two main sections: "CONFIGURATION DATA" and "SMART TRANSMITTER DATA".

CONFIGURATION DATA

PVFORMAT	01	PVCHAR	LINEAR	PVLOPR	NOACTION
PVSRCOPT	ALL	SENSRTYP	SPT_AP	PVROCPPR	NOACTION
PVCLAMP	CLAMP	PIUOTDCF	OFF	PVROCNPR	NOACTION
PVALDR	ONE	BADPVPR	LOW		
PVALDEBEU	2.0000	PVHHPR	NOACTION		
INPTDIR	REVERSE	PVHIPR	NOACTION		
LOCUTOFF	-----	PVLLPR	NOACTION		

SMART TRANSMITTER DATA

STITAG	FT3011	PVRAW	-----	SECVAR	-----
SENSRTYP	SPT_AP	URL	-----	DAMPING	0.00000
PVCHAR	LINEAR	URV	-----	SERIALNO	
CJTACT	OFF	LRV	-----	STISWVER	
PIUOTDCF	OFF	LUL	-----	STATE	LOADFAIL
DECONF	Pv_Db	STI_EU	PSI	COMMAND	NONE

TRANSMITTER SCRATCH PAD:
TRANSMITTER STATUS : COMMAND ALLOWED ONLY ON FIRST
SLOT OF MULTIPLE PV XMTRS
2 OF 2

An arrow points from the error message below to the "COMMAND" field in the SMART TRANSMITTER DATA table.

Message means you can only initiate DECONF download from Detail display for slot 1 or PV number 1.

Continued on next page

A.6 Operation Notes, Continued

PV Engineering Unit Conversions

You can initiate manual engineering unit conversions for PV value used in displays by substituting appropriate converted values for PVEUHI and PVEULO on page one of the Detail display. Use the $Y = mX+B$ formula explained in Section 4 of the *PM/APM Smartline Integration Manual* to calculate the desired PVEUHI and PVEULO values. LRV and URV are used as “X” in the formula. Tables A-9 through A-12 list conversion values that can be used for “m” and “B” in the equation to calculate a desired PV value.

ATTENTION

As a shortcut, you can use the “built-in” conversion available for PV1, PV2, and PV3 by changing the STI_EU parameter and using the values displayed.

Table A-9 Conversion Values for PV1 and PV2 Pressures

Unit	m	B
inH2O@39 °F	1.0	0.0
inH2O@68 °F	1.001784985	0.0
mmHg@0 °C	1.8682681	0.0
PSI	0.03612629	0.0
KPa	0.249082	0.0
MPa	0.000249082	0.0
mBAR	2.49082	0.0
BAR	0.00249082	0.0
g/cm2	2.539929	0.0
Kg/cm2	0.002539929	0.0
inHg@32 °F	0.07355387	0.0
mmH2O@4 °C	25.4	0.0
mH2O@4 °C	0.0254	0.0
ATM	0.00245824582	0.0
inH2O@60 °F	1.000972512	0.0

Table A-10 Conversion Values for PV3 Temperature

Unit	m	B
°C	1.0	0.0
°F	1.8	32.0
K	1.0	273.14844
°R	1.8	491.67188

A.6 Operation Notes, Continued

Engineering Unit Conversion for PV4

Engineering unit conversion for PV4 must be done manually if you want to display PV4 flow calculation in units other than cubic meters per hour. The engineering unit description is entered in the EUDESC parameter in the PED. Then you enter LRV and URV in the detail display for PV4. Next calculate the conversion factor for PVEULO and PVEUHI parameters.

To calculate use the formula: $Y = mX + B$

Where: **Y** is the conversion factor (the result of the calculation that you enter as the PVEVLO or PVEUHI parameter in the detail display.)
m is the conversion multiplier (from table) for the selected engineering units.
X is either LRV or the URV.
B is the conversion offset (from table) for the selected engineering units.

Enter conversion factor as PVEULO parameter.

Table A-11 Conversion Values for PV4 as Volumetric Flow Rate

Preferred Engineering Units	Conversion Multiplier (m)	Conversion Offset (B)
m ³ /h	1.0	0
gal/h	264.172	0
l/h	1,000	0
cc/h	1,000,000	0
m ³ /min	0.01666667	0
gal/min	4.402867	0
l/min	16.66667	0
cc/min	16,666.67	0
m ³ /day	24	0
gal/day	6340.129	0
Kgal/day	6.340129	0
bbl/day	150.9554	0
m ³ /sec	0.0002777778	0
CFM	0.5885777786915	0
CFH	35.31466672149	0

Continued on next page

A.6 Operation Notes, Continued

Engineering Unit Conversion for PV4, continued

Table A-12 Conversion Values for PV4 as Mass Flow Rate

Preferred Engineering Units	Conversion Multiplier (m)	Conversion Offset (B)
t/h	1.0	0
kg/h	1,000	0
kg/min	16.66667	0
lb/min	36.74371	0
lb/h	2204.623	0
kg/sec	0.277778	0
lb/sec	0.612395	0
t/min	0.0166666	0
t/sec	0.000277477	0
g/h	1,000,000	0
g/min	16666.67	0
g/sec	277.77789	0
ton/h	1.1023113	0
ton/min	0.01837175	0
ton/sec	0.00030591	0

Secondary Variable Reference

If the SMV 3000 transmitter's PV Type configuration is PV1 w/SV, the SECVAR field on page 2 of the detail display for slot 1 shows the temperature of the meter body as the secondary variable. The base engineering unit for the secondary variable is degrees Celsius.

Continued on next page

A.6 Operation Notes, Continued

Status Messages

Supplement the IOP status messages given in Section 8 of the PM/APM Smartline Transmitter Integration Manual with those listed in Table A-13. Note that the displayed status messages will be the same for all slots (PVs) associated with a given SMV 3000 transmitter.

Table A-13 Additional IOP Status Messages

Message	Problem	Corrective Action
COMMAND ALLOWED ONLY ON FIRST SLOT OF MULTIPLE PV XMTRS	Attempted to download database with DECONF change from slot 2, 3, or 4.	Call up slot 1 Detail display for PV1 and retry database download command.
COMMAND FAILURE . . . BUSY	Command could not be executed because transmitter is busy	Retry command.
CONFIGURATION MISMATCH MULTIPLE DEVICES ASSIGNED TO SLOT	Another transmitter is physically connected to a logical slot for a multivariable transmitter.	Disconnect offending transmitter or reconfigure the number of PVs for the SMV 3000 transmitter.
TRANSMITTER IS BROADCASTING A SUBSTITUTE VALUE PV	Transmitter is in output mode or input mode.	Use SCT 3000 to remove transmitter from output mode or input mode.

Bad PV Indication

In most cases, configuration error detection will result in a Bad PV (BP) indication for all slots (PVs) associated with a given SMV 3000 transmitter. However, if the number of IOP slots allocated differs from the number of PVs configured in the SMV 3000 transmitter, only the slots reserved by the IOP will be flagged as bad. A download command from slot 1 usually clears Bad PV indication from all but the offending slot (PV). You will have to make configuration changes to resolve slot conflicts.

Appendix B —SMV 3000 Configuration Record Sheet

**SMV 3000
Configuration Data
Sheets**

The following configuration sheets provide a means to record the SMV 3000 configuration database. You may want to fill it out prior to creating the transmitter database file or before performing on-line configuration. These sheets contain all of the configuration parameters for the SMV 3000. The default values are shown in **bold**.

SMV 3000 Model #: _____	
1. General Configuration Section	
Tag I.D. Number: (8 Characters Max.)	_____
Scratch Pad: (32 Characters Max.)	_____
Mode of Operation:	Analog _____ DE _____
Analog Output Choice:	PV1 _____ PV2 _____ PV3 _____ PV4 _____
PV DE Mode Broadcast: (only required if selecting DE Mode of Operation)	PV1 On _____ PV1 On w/SV _____
	PV1 - PV2 On _____ PV1 - PV2 On w/SV1 _____
	PV1 - PV3 On _____ PV1 - PV3 On w/SV1 _____
	PV1 - PV4 On _____ PV1 - PV4 On w/SV1 _____
Line Filter:	50 Hz _____ 60 Hz _____
Failsafe Direction: (Analog Mode Only)	Upscale _____ Downscale _____
1a. Differential Pressure - PV1 - Configuration Section	
PV1 Output Conformity:	Linear _____ Square Root _____
PV1 Damping (sec.):	0.0 _____ 0.16 _____ 0.32 _____ 0.48 _____ 1 _____ 2 _____ 4 _____ 8 _____ 16 _____ 32 _____
PV1 Eng. Units:	"H2O_39F _____ PSI _____ MPa _____ bar _____ kg/cm ² _____ mmH2O_4C _____ mmHg_0C _____ KPa _____ mbar _____ g/cm ² _____ inHg_32F _____ ATM _____ mH2O_4C _____ "H2O_68F _____ "H2O_60F _____
PV1 Range: (defaults are 0 and 100 inches H2O 39F)	LRV _____ URV _____

Continued on next page

Appendix B– Configuration Record Sheet, Continued

1b. Static Pressure - PV2 - Configuration Section

PV2 Damping (sec.): 0.0 ___ 0.16 ___ 0.32 ___ 0.48 ___ 1 ___ 2 ___
 4 ___ 8 ___ 16 ___ 32 ___

PV2 Eng. Units: "H2O_39F ___ **PSI** ___ MPa ___ bar ___
 (Static Pressure) kg/cm^2 ___ mmH2O_4C ___ mmHg_0C ___ KPa ___
 mbar ___ g/cm^2 ___ inHg_32F ___ ATM ___
 mH2O_4C ___ "H2O_68F ___ "H2O_60F ___

PV2 Range: LRV ___ URV ___
 (default depends on SMV 3000 model number - specify gauge or absolute)

Barometric Pressure: _____
 (If using SMV 3000 in a flow application and you specify the SMG170 model number, enter the barometric pressure)
 (Default is 14.7 psia)

1c. Process Temperature - PV3 - Configuration Section

PV3 Damping (sec.): 0.0 ___ 0.3 ___ 0.7 ___ 1.5 ___ 3.1 ___ 6.3 ___
 12.7 ___ 25.5 ___ 51.1 ___ 102.3 ___

PV3 Probe Type: **PT 100 D RTD** ___ Type E TC ___ Type J TC ___
 Type K TC ___ Type T TC ___

PV3 Eng. Units: **deg. C** ___ deg. F ___ deg. R ___

PV3 Range: LRV ___ URV ___
 (defaults are -200 and 450 deg. C)

PV3 Cold Junc. Comp.: **Internal** ___ External ___ ECJT: ___
 (Only for Thermocouple. If external, specify the temp. in the ECJT slot)

PV3 TC Fault Detection: **On** ___ Off ___

PV3 Output Charact.: **Linear** ___ Non-Linear ___

Continued on next page

Appendix B– Configuration Record Sheet, Continued

2. Flow - PV4 - Configuration Section

(If using SMV 3000 for PV1, PV2 and PV3 measurement only, do not complete flow section.)

2a. Dynamic Flow Compensation Section

(If you are using a primary element that is not listed, use the Standard Flow Equation Section below.)

Flow Element Type:

Orifice - Flange Taps (ASME-ISO) $D \geq 2.3$ inches _____
 Orifice - Flange Taps (ASME-ISO) $2 \leq D \leq 2.3$ _____
 Orifice - Corner Taps (ASME-ISO) _____
 Orifice - D and D/2 Taps (ASME-ISO) _____
 Orifice - 2.5D and 8D Taps (ASME-ISO) _____ (Liquids only)
 Venturi - Machined Inlet (ASME-ISO) _____ (Liquids only)
 Venturi - Rough Cast Inlet (ASME-ISO) _____ (Liquids only)
 Venturi - Rough Welded Sheet-Iron Inlet (ASME-ISO) _____ (Liquids only)
 Nozzle (ASME Long Radius) _____ (Liquids only)
 Venturi nozzle (ISA Inlet) _____ (Liquids only)
 Leopold venturi _____ (Liquids only)
 Gerand venturi _____ (Liquids only)
 Universal Venturi Tube _____ (Liquids only)
 Lo-Loss Venturi Tube _____ (Liquids only)
 Preso Ellipse Ave. Pitot Tube _____ (Specify 7/8", 1.25" or 2.25" Probe diameter)

Material _____

Bore Diameter (inches at 68 deg. F) _____ (not required for Pitot Tube)

Design Temperature _____ (not required for Pitot Tube)

Fluid State: Gas _____ Liquid _____ Steam _____

Flow Data: (obtained from Primary Element Sizing Sheet)

Design Pressure _____ (required only for Gas applications)

Design Temperature _____ (required only for Gas applications)

Design Density _____ (required only for Steam applications)

Standard Density _____ (required only for Standard Volume equations)

Fluid Name: _____

Pipe Properties: Material _____ Pipe Schedule _____ Pipe Diameter _____

Isentropic Exponent: _____ (not required for Liquid applications or Pitot Tube)

2b. Standard Flow Compensation Section

(Standard equation should be used for any primary element not listed in Dynamic Flow Section above.)

Fluid State: Gas _____ Liquid _____ Steam _____

Fluid Name: _____

Flow Data: (obtained from Primary Element Sizing Sheet)

Normal Flowrate _____ Design Pressure _____ (Gas applications only)

Normal Diff. Pressure _____ Design Temperature _____ (Gas applications only)

Design Density _____ (required only for Steam and Liquid applications)

Standard Density _____ (required only for Standard Volume equations)

Flow Compensation: None ___ Full ___ Pressure Only ___ Temperature Only ___

Continued on next page

Appendix B– Configuration Record Sheet, Continued

2c. General Flow Configuration Section

PV4 Range: LRV _____ URV _____ URL _____
 (defaults are 0, 100,000 and 100,000 m3/hr)

PV4 Eng. Units: cc/h _____ cc/min _____ l/h _____ l/min _____
 (Volumetric Flow) gal/day _____ Kgal/day _____ gal/h _____ gal/min _____
 bbl/day _____ m3/day _____ **m3/hr** _____ m3/min _____
 m3/sec _____ CFM _____ CFH _____

Type of Volumetric Flow Units:
 Standard Volume Units _____ Actual Volume Units _____

PV4 Eng. Units: lb/min _____ lb/h _____ lb/sec _____ ton/sec _____
 (Mass Flow) ton/min _____ ton/h _____ kg/min _____ kg/sec _____
 kg/h _____ t/min _____ **t/h** _____ t/sec _____
 g/sec _____ g/min _____ g/h _____

PV4 Eng. Units: _____ **Conversion Factor =** _____
 (Complete if choosing Custom Units, 8 characters Max.)

PV4 Damping (sec.): 0.0 _____ 0.5 _____ 1.0 _____ 2.0 _____ 3.0 _____ 4.0 _____
 5.0 _____ 10 _____ 50 _____ 100 _____

PV4 Low Flow Cutoff: Low Limit _____ High Limit _____ (defaults are zero)

PV4 Failsafe: PV2 Failsafe On _____ **PV2 Failsafe Off** _____ Pressure _____
 PV3 Failsafe On _____ **PV3 Failsafe Off** _____ Temperature _____

Configured By: _____ **Date:** ____/____/____

Custom Fluids -

Liquid Applications - If you are using a custom fluid that is not listed in the SCT 3000 Flow Compensation Wizard, you can supply values for density vs. temperature and viscosity vs. temperature in the flow equation (if dynamic compensation is desired). If dynamic compensation is not desired, enter the density and viscosity values at normal flowing conditions.

Density – lbs/ft ³	viscosity – cPoise	temperature – deg. F
_____	_____	_____
_____	_____	_____
_____	_____	_____
_____	_____	_____

Gas and Steam Applications - If you are using a custom gas that is not listed in the SCT 3000 Flow Compensation Wizard, you can supply values for viscosity vs. temperature in the flow equation (if dynamic viscosity is desired). If dynamic compensation is not desired, enter the viscosity values at normal flowing conditions.

viscosity – cPoise	temperature – deg. F
_____	_____
_____	_____
_____	_____
_____	_____

Appendix C —PV4 Flow Variable Equations

C.1 Overview

Appendix Contents

This appendix includes these topics:

Topic	See Page
C.1 Overview	175
C.2 Standard Flow Equation	176
C.3 Dynamic Compensation Flow Equation	181

Purpose of this appendix

This appendix gives a brief description on the use of the available flow equations for calculating the SMV 3000's PV4 flow variable. Configuration examples for a number of flow applications are provided to show how to configure SMV PV4 flow variable using the SCT 3000 flow compensation wizard.

Reader Assumptions

It is assumed that you are familiar with the flow application in which the SMV 3000 multivariable transmitter is to be used and that you are familiar with using the SCT 3000 Smartline configuration Toolkit.

Reference Data Sources

Consult the following references to obtain data that are necessary and helpful for configuring the SMV PV4 flow variable:

- The flow element manufacturer's documentation.
 - The process fluid manufacturer's documentation on fluid density and viscosity characteristics.
 - *Flow Measurement Engineering Handbook*, by Richard W. Miller, McGraw-Hill, Third Edition, 1996.
 - The flow application examples in this appendix give actual configuration setups.
-

C.2 Standard Flow Equation

Standard Flow Compensation (Kuser Model)

The Standard Flow Equation (Kuser Model) allows automatic calculation of the Kuser value that is used to configure PV4 flow variable for SMV 3000. The Kuser value is a scaling factor, based on the dynamics of your process, which is used to adjust the flow rate to the desired process parameters, such as

- dimensional units
- density
- pressure
- temperature.

The standard flow model uses an empirical method to configure PV4 flow variable for the following primary elements:

- orifice plates
- Venturis
- nozzles
- averaging pitot tubes
- and other flow elements with outputs proportional to \sqrt{DP} .

The standard flow model can be used to calculate PV4 for volumetric and mass flow rates for gas, liquid, and steam at standard conditions. A flow equation for steam mass is also available which compensates for density based on the ASME steam tables

NOTE: Use the dynamic flow compensation model for increased flow measurement accuracy. See Subsection C.3.

Standard Flow Equation Configuration Examples

The following pages contain two examples for configuring the SMV PV4 output using the Flow Compensation Wizard in the SCT 3000 configuration program. The configuration examples show how to navigate through the wizard program and enter values to configure the SMV PV4 flow variable for a given flow application. Examples for the following applications are presented:

- Air through a Venturi meter
- Superheated Steam

The standard (Kuser) model wizard in the SCT 3000 is started from the Equation Model page of the Flow Compensation Wizard.

Continued on next page

C.2 Standard Flow Equation, Continued

Example: Air Through a Venturi

An engineer has specified a SMV 3000 Smart Multivariable Transmitter to compensate for air density changes and to calculate the standard volumetric flowrate of air through a Venturi meter. The engineer has sized the Venturi meter to produce a differential pressure of 49 inches H₂O at 630 CFM at standard conditions. The flowing pressure is 129.7 psia, flowing temperature is 100 degrees F, and the standard (base) density is 0.0764 lbs/ft³.

The steps in Table C-1 show how to configure the SMV to calculate the PV4 flow variable for this application.

Table C-1 Air Through a Venturi Meter Configuration Example

Step	Action
1	Select a template for the SMV 3000 model you have for your flow application. Select standard volume flow in the Algorithm field of the FlowAlg tab and then select the Engineering Units (CFM) on the FlowConf tab card.
2	Click the Wizard . . . on the SCT/SMV 3000 configuration window to access the Flow Compensation Wizard Equation Model page.
3	Select Standard from the Equation Model list box on the Equation Model page of the Flow Compensation Wizard to launch the Kuser Model, then click <i>Next</i> to proceed to the Fluid Type page.
4	Select Gas as the fluid type from the list box on the Fluid Type page, then <i>Next</i> to proceed to the Gas Flow Type page.
5	Select Standard Volume as the gas flow type from the list box on the Gas Flow Type page, then click <i>Next</i> to proceed to the Process Data page.

Continued on next page

C.2 Standard Flow Equation, Continued

Table C-1 Air Through a Venturi Meter Configuration Example, continued

Step	Action												
6	<p>Enter the relevant flow process data from the Venturi Sizing Data Sheet into the appropriate entry fields on the Process Data page as follows:</p> <table border="1" data-bbox="688 611 1341 873"> <tr> <td>Normal Flowrate</td> <td>= 630 CFM</td> </tr> <tr> <td>Normal DP</td> <td>= 49 inches H₂O @ 39.2 °F</td> </tr> <tr> <td>Design Pressure</td> <td>= 129.7 psia</td> </tr> <tr> <td>Design Temperature</td> <td>= 100°F</td> </tr> <tr> <td>Standard Density</td> <td>= 0.0764 lbs/ft³</td> </tr> <tr> <td>Compensation Mode</td> <td>= Full</td> </tr> </table> <p>You can change the engineering units by clicking on the text box with the right mouse button.</p> <p>Click <i>Next</i> to proceed to the Flowing Variables page.</p>	Normal Flowrate	= 630 CFM	Normal DP	= 49 inches H ₂ O @ 39.2 °F	Design Pressure	= 129.7 psia	Design Temperature	= 100°F	Standard Density	= 0.0764 lbs/ft ³	Compensation Mode	= Full
Normal Flowrate	= 630 CFM												
Normal DP	= 49 inches H ₂ O @ 39.2 °F												
Design Pressure	= 129.7 psia												
Design Temperature	= 100°F												
Standard Density	= 0.0764 lbs/ft ³												
Compensation Mode	= Full												
7	<p>Click the following options for failsafe indication on the Flowing Variables page (so that there is an “✓” in each check box):</p> <table border="1" data-bbox="688 1136 1055 1220"> <tr> <td><input checked="" type="checkbox"/></td> <td>Abs. Pressure</td> </tr> <tr> <td><input checked="" type="checkbox"/></td> <td>Process Temp</td> </tr> </table> <p>This will ensure that the PV4 flow output will go to failsafe if either the static pressure or temperature sensors fail.</p> <ul style="list-style-type: none"> • Set Damping = 1.0 seconds. <p>Click <i>Next</i> to proceed to the Solutions page.</p>	<input checked="" type="checkbox"/>	Abs. Pressure	<input checked="" type="checkbox"/>	Process Temp								
<input checked="" type="checkbox"/>	Abs. Pressure												
<input checked="" type="checkbox"/>	Process Temp												
8	<p>The calculated Kuser value appears on the Solutions page of the Kuser Model along with a list of items (with values) that you have configured from previous pages. Review the Wizard values to make sure they are correct.</p> <p>Click <i>Finish</i> to complete the Kuser calculation procedure.</p>												
9	<p>Connect SCT to SMV and establish communications. (See subsection 5.2 for procedure, if necessary.)</p>												
10	<p>Perform Download of the database configuration file to the SMV.</p>												
11	<p>Use the procedure in subsection 7.5, <i>Using Transmitter to Simulate PV Input</i> to verify the Kuser and flow calculation for this application. You can simulate inputs for PV1, PV2, and PV3 to verify PV4 output.</p>												

Continued on next page

C.2 Standard Flow Equation, Continued

Example: Superheated Steam Using an Averaging Pitot Tube

An engineer has specified a SMV 3000 Smart Multivariable Transmitter to compensate for steam density changes and to calculate the mass flowrate of superheated steam using an averaging pitot tube. The engineer has sized the averaging pitot tube to produce a differential pressure of 13.21 inches H₂O at 45,000 lb/hr. The flowing pressure is 294.7 psia, flowing temperature is 590 degrees F, and flowing density is 0.49659 lbs/ft³.

The steps in Table C-2 show how to configure the SMV to calculate the PV4 flow variable for this application.

Table D-2 Superheated Steam using an Averaging Pitot Tube Configuration Example

Step	Action						
1	Select a template for the SMV 3000 model you have for your flow application. Select superheated steam mass flow in the Algorithm field of the FlowAlg tab and then select the Engineering Units (lb/h) on the FlowConf tab card.						
2	Click the Wizard . . . on the SCT/SMV 3000 configuration window to access the Flow Compensation Wizard Equation Model page.						
3	Select Standard from the Equation Model list box on the Equation Model page of the Flow Compensation Wizard to launch the Kuser Model, then click <i>Next</i> to proceed to the Fluid Type page.						
4	Select Steam as the fluid type from the list box on the Fluid Type page, then click <i>Next</i> to proceed to the Process Data page.						
5	Enter the relevant flow process data from the Averaging Pitot Tube Sizing Data Sheet into the appropriate entry fields on the Process Data page as follows: <table border="1" data-bbox="685 1499 1341 1625"> <tbody> <tr> <td>Normal Flowrate</td> <td>= 45,000 lb/hr</td> </tr> <tr> <td>Normal DP</td> <td>= 13.21 inches H₂O @ 39.2 °F</td> </tr> <tr> <td>Design Density</td> <td>= 0.49659 lbs/ft³</td> </tr> </tbody> </table> <p>You can change the engineering units by clicking on the text box with the right mouse button.</p> <p>Click <i>Next</i> to proceed to the Flowing Variables page.</p>	Normal Flowrate	= 45,000 lb/hr	Normal DP	= 13.21 inches H ₂ O @ 39.2 °F	Design Density	= 0.49659 lbs/ft ³
Normal Flowrate	= 45,000 lb/hr						
Normal DP	= 13.21 inches H ₂ O @ 39.2 °F						
Design Density	= 0.49659 lbs/ft ³						

Continued on next page

C.2 Standard Flow Equation, Continued

Table C-2 Superheated Steam using an Averaging Pitot Tube Configuration Example, Continued

Step	Action				
6	<p>Click the following options for failsafe indication on the Flowing Variables page (so that there is an "✓" in each check box):</p> <table border="1" data-bbox="685 556 1055 638"> <tr> <td data-bbox="685 556 803 594">✓</td> <td data-bbox="807 556 1055 594">Abs. Pressure</td> </tr> <tr> <td data-bbox="685 598 803 636">✓</td> <td data-bbox="807 598 1055 636">Process Temp</td> </tr> </table> <p>This will ensure that the PV4 flow output will go to failsafe if either the static pressure or temperature sensors fail.</p> <ul style="list-style-type: none"> • Set Damping = 1.0 seconds. <p>Click <i>Next</i> to proceed to the Solutions page.</p>	✓	Abs. Pressure	✓	Process Temp
✓	Abs. Pressure				
✓	Process Temp				
7	<p>The calculated Kuser value appears on the Solutions page of the Kuser Model along with a list of items (with values) that you have configured from previous pages. Review the Wizard values to make sure they are correct.</p> <p>Click <i>Finish</i> to complete the Kuser calculation procedure.</p>				
8	<p>Connect SCT to SMV and establish communications. (See subsection 5.2 for procedure, if necessary.)</p>				
9	<p>Perform Download of the database configuration file to the SMV.</p>				
10	<p>Use the procedure in subsection 7.5, <i>Using Transmitter to Simulate PV Input</i> to verify the Kuser and flow calculation for this application. You can simulate inputs for PV1, PV2, and PV3 to verify PV4 output.</p>				

C.3 Dynamic Compensation Flow Equation

Dynamic Compensation Flow Equation

The Dynamic Compensation Flow Equation provides algorithms for use in determining a highly accurate PV4 flow variable for SMV 3000. Use dynamic compensation to measure liquids, gases, and steam.

Dynamic compensation flow equation compensates for:

- temperature
- pressure
- density
- discharge coefficient (gas, liquid, or steam)
- thermal expansion factor
- gas expansion factor

NOTE: A standard flow equation is also available which uses an empirical method of calculation for PV4, thereby compensating only for temperature and pressure changes in gas and steam applications. See Subsection C.2.

Dynamic Compensation Configuration Examples

The following pages contain three examples for configuring the SMV PV4 output using the Flow Compensation wizard in the SCT 3000 configuration program. The configuration examples show how to navigate through the wizard program and enter values to configure the SMV PV4 flow variable for a given flow application. Examples for the following applications are presented:

- Liquid Propane
- Air
- Superheated Steam

The Dynamic Compensation Flow model wizard in the SCT 3000 program is launched from the Equation Model page of the Flow Compensation Wizard.

Example: Liquid Propane

An engineer has specified a SMV 3000 Smart Multivariable Transmitter to dynamically compensate and calculate the mass flowrate of liquid propane through a standard 304 SS orifice meter with flange taps. The engineer has sized the orifice meter to produce a differential pressure of 64 inches H₂O at 555.5 lb/m. The flowing pressure is 314.7 psia and the flowing temperature is 100 degrees F.

The steps in Table C-3 shows how to configure the SMV to calculate the PV4 flow variable for this application.

Continued on next page

C.3 Dynamic Compensation Flow Equation, Continued

Table C-3 Liquid Propane Configuration Example

Step	Action								
1	<p>Select a template for the SMV 3000 model you have for your flow application.</p> <p>Select mass flow in the Algorithm field of the FlowAlg tab and then select the Engineering Units (lb/m) on the FlowConf tab card.</p>								
2	<p>Click the Wizard . . . on the SCT/SMV 3000 configuration window to access the Flow Compensation Wizard Equation Model page.</p>								
3	<p>Select Dynamic Corrections from the list box on the Equation Model page of the Flow Compensation Wizard to invoke the Dynamic Flow Compensation Model, then click <i>Next</i> to proceed to the Flow Element Properties page.</p>								
4	<p>Enter the relevant information from the Orifice Sizing Data Sheet in each entry field of the Flow Element Properties page:</p> <table border="1" data-bbox="686 938 1341 1146" style="margin-left: 40px;"> <tr> <td>Element Type</td> <td>= Flange tap (D greater than 2.3 inches)</td> </tr> <tr> <td>Bore Diameter</td> <td>= 1.8611 inches</td> </tr> <tr> <td>Material</td> <td>= 304 SS</td> </tr> <tr> <td>Flowing Temperature</td> <td>= 100°F</td> </tr> </table> <ul style="list-style-type: none"> • The expansion coefficient is automatically calculated based on the entered data. <p>Click <i>Next</i> to proceed to the Fluid State page.</p>	Element Type	= Flange tap (D greater than 2.3 inches)	Bore Diameter	= 1.8611 inches	Material	= 304 SS	Flowing Temperature	= 100°F
Element Type	= Flange tap (D greater than 2.3 inches)								
Bore Diameter	= 1.8611 inches								
Material	= 304 SS								
Flowing Temperature	= 100°F								
5	<p>Select the fluid state as Liquid from the list on the Fluid State page, then click <i>Next</i> to proceed to the Liquid Flow page.</p>								
6	<p>Select Mass as the type of liquid flow from the list box on the Liquid Flow page, then click <i>Next</i> to proceed to the Fluid page.</p>								
7	<p>Select PROPANE as the type of fluid from the list box on the Fluid page, then click <i>Next</i> to proceed to the Pipe Properties page.</p>								
8	<p>Enter the relevant information from the Orifice Sizing Data Sheet in each entry field of the Pipe Properties page:</p> <table border="1" data-bbox="686 1642 1151 1770" style="margin-left: 40px;"> <tr> <td>Pipe Schedule</td> <td>= 40s</td> </tr> <tr> <td>Nominal diameter</td> <td>= 4 inches</td> </tr> <tr> <td>Material</td> <td>= Carbon Steel</td> </tr> </table> <ul style="list-style-type: none"> • The actual diameter and thermal expansion coefficient for the pipe are automatically calculated based on the entered data. • Click <i>Next</i> to proceed to the Discharge Coefficient page. 	Pipe Schedule	= 40s	Nominal diameter	= 4 inches	Material	= Carbon Steel		
Pipe Schedule	= 40s								
Nominal diameter	= 4 inches								
Material	= Carbon Steel								

Continued on next page

C.3 Dynamic Compensation Flow Equation, Continued

Table C-3 Liquid Propane Configuration Example, continued

Step	Action						
9	<p>Enter the following lower and upper Reynolds number limits in each entry field of the Discharge Coefficient page. These values are used to clamp the discharge coefficient equation at these Reynolds numbers:</p> <table border="1" data-bbox="686 583 1055 667"> <tr> <td>Lower Limit</td> <td>= 80,000</td> </tr> <tr> <td>Upper Limit</td> <td>= 800,000</td> </tr> </table> <ul style="list-style-type: none"> Click <i>Next</i> to proceed to the Viscosity Compensation page. Graph coordinates (Reynolds Number vs. Discharge Coefficient) will appear when the mouse is clicked on the graph. 	Lower Limit	= 80,000	Upper Limit	= 800,000		
Lower Limit	= 80,000						
Upper Limit	= 800,000						
10	<p>Enter the following equation order (order 4 is recommended) and temperature limits for the viscosity compensation in each entry field of the Viscosity Compensation page. The viscosity values will be clamped at the temperature limits.</p> <table border="1" data-bbox="686 978 1055 1108"> <tr> <td>Order</td> <td>= 4</td> </tr> <tr> <td>Low Temp</td> <td>= 50</td> </tr> <tr> <td>High Temp</td> <td>= 150</td> </tr> </table> <p>Click <i>Yes</i> to refit the curve with the new limits.</p> <ul style="list-style-type: none"> Graph coordinates will appear when the mouse is clicked on the graph. <p>Select <i>Next</i> to proceed to the Density Compensation page.</p>	Order	= 4	Low Temp	= 50	High Temp	= 150
Order	= 4						
Low Temp	= 50						
High Temp	= 150						
11	<p>Enter the following equation order and temperature limits for the density compensation in each entry field of the Density Compensation page. The density values used in the flow calculation will be clamped at the temperature limits.</p> <table border="1" data-bbox="686 1465 1055 1596"> <tr> <td>Order</td> <td>= 4</td> </tr> <tr> <td>Low Temp</td> <td>= 50</td> </tr> <tr> <td>High Temp</td> <td>= 150</td> </tr> </table> <p>Click <i>Yes</i> to refit the curve with the new limits.</p> <ul style="list-style-type: none"> Graph coordinates will appear when the mouse is clicked on the graph. <p>Select <i>Next</i> to proceed to the Flowing Variables page.</p>	Order	= 4	Low Temp	= 50	High Temp	= 150
Order	= 4						
Low Temp	= 50						
High Temp	= 150						

Continued on next page

C.3 Dynamic Compensation Flow Equation, Continued

Table C-3 Liquid Propane Configuration Example, continued

Step	Action				
12	<p>Click on the following options for Failsafe Indication on the Flowing Variables page (so that there is an “✓” in each check box). It has been determined that the operator needs the flow output to go to failsafe when there is either a pressure or temperature failure (selecting Abs. Pressure and Process Temp. will assure this).</p> <table border="1" data-bbox="686 617 1055 699"> <tr> <td data-bbox="686 617 808 657">✓</td> <td data-bbox="808 617 1055 657">Abs. Pressure</td> </tr> <tr> <td data-bbox="686 657 808 699">✓</td> <td data-bbox="808 657 1055 699">Process Temp</td> </tr> </table> <ul data-bbox="643 720 1442 951" style="list-style-type: none"> • Set damping for the flow output at 1.0 seconds. • Since Flow Failsafe has been selected for a pressure or temperature failure, the default values do not need to be set. If failsafe for the flow output is not needed when a pressure or temperature sensor fails, the default values for temperature and pressure are used in the flow calculation and the flowrate continues to be reported. <p>Click <i>Next</i> to proceed to the Solutions page.</p>	✓	Abs. Pressure	✓	Process Temp
✓	Abs. Pressure				
✓	Process Temp				
13	<p>The Solutions page presents itemized columns representing the data entered and the corresponding Wizard values that were calculated from the Wizard table data. Many of these values are used inside the SMV 3000 Multivariable Transmitter to compensate and calculate the flow for your application. Review the data to make sure the correct choices have been made based on your flow application.</p> <p>Click <i>Finish</i> to complete the Flow Compensation Wizard.</p>				
14	<p>Connect SCT to SMV and establish communications. (See subsection 5.2 for procedure, if necessary.)</p>				
15	<p>Perform Download of the database configuration file to the SMV.</p>				
16	<p>Use the procedure in subsection 7.5, <i>Using Transmitter to Simulate PV Input</i> to verify the flow calculation for this application. You can simulate inputs for PV1, PV2, and PV3 to verify PV4 output.</p>				

Continued on next page

C.3 Dynamic Compensation Flow Equation, Continued

Example: Air

An engineer has specified a SMV 3000 Smart Multivariable Transmitter to dynamically compensate and calculate the standard volumetric flowrate of air through a standard 304 SS orifice meter with flange taps. The engineer has sized the orifice meter to produce a differential pressure of 10 inches H₂O at 175 standard cubic feet per minute (SCFM). The flowing pressure is 40 psia, the flowing temperature is 60 degrees F, the flowing density is 0.2079 lbs/ft³, and the standard density is 0.0764 lbs/ft³.

The steps in Table C-4 shows how to configure the SMV to calculate the PV4 flow variable for this application.

Table C-4 Air Configuration Example

Step	Action								
1	<p>Select a template for the SMV 3000 model you have for your flow application.</p> <p>Select Standard Volumetric flow in the Algorithm field of the FlowAlg tab and then select the Engineering Units (CFM) on the FlowConf tab card.</p>								
2	<p>Click the Wizard . . . on the SCT/SMV 3000 configuration window to access the Flow Compensation Wizard Equation Model page.</p>								
3	<p>Select Dynamic Corrections from the list box on the Equation Model page of the Flow Compensation Wizard to invoke the Dynamic Flow Compensation Model, then click <i>Next</i> to proceed to the Flow Element Properties page.</p>								
4	<p>Enter the relevant information from the Orifice Sizing Data Sheet in each entry field of the Flow Element Properties page:</p> <table border="1" style="margin-left: 40px;"> <tr> <td>Element Type</td> <td>= Flange tap (D Greater than 2.3 inches)</td> </tr> <tr> <td>Bore Diameter</td> <td>= 1.5698 inches</td> </tr> <tr> <td>Material</td> <td>= 304 SS</td> </tr> <tr> <td>Flowing Temperature</td> <td>= 60°F</td> </tr> </table> <ul style="list-style-type: none"> • The expansion coefficient is automatically calculated based on the entered data. <p>Click <i>Next</i> to proceed to the Fluid State page.</p>	Element Type	= Flange tap (D Greater than 2.3 inches)	Bore Diameter	= 1.5698 inches	Material	= 304 SS	Flowing Temperature	= 60°F
Element Type	= Flange tap (D Greater than 2.3 inches)								
Bore Diameter	= 1.5698 inches								
Material	= 304 SS								
Flowing Temperature	= 60°F								
5	<p>Select the fluid state as Gas from the list box on the Fluid State page, then click <i>Next</i> to proceed to the Gas Flow page.</p>								

Continued on Next page

C.3 Dynamic Compensation Flow Equation, Continued

Table C-4 Air Configuration Example, continued

Step	Action						
6	Select Standard Volume as the type of gas flow from the list box on the Gas Flow page, then click <i>Next</i> to proceed to the Fluid page.						
7	Select AIR as the type of fluid from the list box on the Fluid page, then click <i>Next</i> to proceed to the Pipe Properties page.						
8	<p>Enter the relevant information from the Orifice Sizing Data Sheet in each entry field of the Pipe Properties page:</p> <table border="1" data-bbox="688 709 1198 835"> <tr> <td>Pipe Schedule</td> <td>= 40s</td> </tr> <tr> <td>Nominal diameter</td> <td>= 3 inches</td> </tr> <tr> <td>Material</td> <td>= Carbon Steel</td> </tr> </table> <ul style="list-style-type: none"> The actual diameter and thermal expansion coefficient for the pipe are automatically calculated based on the entered data. <p>Click <i>Next</i> to proceed to the Discharge Coefficient page.</p>	Pipe Schedule	= 40s	Nominal diameter	= 3 inches	Material	= Carbon Steel
Pipe Schedule	= 40s						
Nominal diameter	= 3 inches						
Material	= Carbon Steel						
9	<p>Enter the following lower and upper Reynolds number limits in each entry field of the Discharge Coefficient page. These values are used to clamp the discharge coefficient equation at these Reynolds numbers:</p> <table border="1" data-bbox="688 1161 1055 1245"> <tr> <td>Lower Limit</td> <td>= 10,000</td> </tr> <tr> <td>Upper Limit</td> <td>= 100,000</td> </tr> </table> <ul style="list-style-type: none"> Graph coordinates (Reynolds Number vs. Discharge Coefficient) will appear when the mouse is clicked on the graph. <p>Click <i>Next</i> to proceed to the Viscosity Compensation page.</p>	Lower Limit	= 10,000	Upper Limit	= 100,000		
Lower Limit	= 10,000						
Upper Limit	= 100,000						
10	<p>Enter the following equation order (order 4 is recommended) and temperature limits for the viscosity compensation in each entry field of the Viscosity Compensation page. The viscosity values will be clamped at the temperature limits.</p> <table border="1" data-bbox="688 1570 1055 1696"> <tr> <td>Order</td> <td>= 4</td> </tr> <tr> <td>Low Temp</td> <td>= 50</td> </tr> <tr> <td>High Temp</td> <td>= 150</td> </tr> </table> <p>Click <i>Yes</i> to refit the curve with the new limits.</p> <ul style="list-style-type: none"> Graph coordinates will appear when the mouse is clicked on the graph. <p>Click <i>Next</i> to proceed to the Density Variables page.</p>	Order	= 4	Low Temp	= 50	High Temp	= 150
Order	= 4						
Low Temp	= 50						
High Temp	= 150						

Continued on Next page

C.3 Dynamic Compensation Flow Equation, Continued

Table C-4 Air Configuration Example, continued

Step	Action										
10	<p>Enter the relevant process information from the Orifice Sizing Data Sheet in each entry field of the Density Variables page.</p> <table border="1" data-bbox="688 522 1247 741"> <tr> <td>Isentropic Exponent *</td> <td>= 1.4044</td> </tr> <tr> <td>Design (flowing) Density</td> <td>= 0.2079 lb/ft³</td> </tr> <tr> <td>Standard (base) Density</td> <td>= 0.0764 lb/ft³</td> </tr> <tr> <td>Design Temperature</td> <td>= 60°F</td> </tr> <tr> <td>Design Pressure</td> <td>= 40 psia</td> </tr> </table> <p>Click <i>Next</i> to proceed to the Flowing Variables page.</p>	Isentropic Exponent *	= 1.4044	Design (flowing) Density	= 0.2079 lb/ft ³	Standard (base) Density	= 0.0764 lb/ft ³	Design Temperature	= 60°F	Design Pressure	= 40 psia
Isentropic Exponent *	= 1.4044										
Design (flowing) Density	= 0.2079 lb/ft ³										
Standard (base) Density	= 0.0764 lb/ft ³										
Design Temperature	= 60°F										
Design Pressure	= 40 psia										
11	<p>Click on the following options for Failsafe Indication on the Flowing Variables page (so that there is an “✓” in each check box). It has been determined that the operator needs the flow output to go to failsafe when there is either a pressure or temperature failure (selecting Abs. Pressure and Process Temp. will assure this).</p> <table border="1" data-bbox="688 999 1055 1083"> <tr> <td><input checked="" type="checkbox"/></td> <td>Abs. Pressure</td> </tr> <tr> <td><input checked="" type="checkbox"/></td> <td>Process Temp</td> </tr> </table> <ul style="list-style-type: none"> • Set damping for the flow output at 1.0 seconds. • Since Flow Failsafe has been selected for a pressure or temperature failure, the default values do not need to be set. If failsafe for the flow output is not needed when a pressure or temperature sensor fails, the default values for temperature and pressure are used in the flow calculation and the flowrate continues to be reported. <p>Click <i>Next</i> to proceed to the Solutions page.</p>	<input checked="" type="checkbox"/>	Abs. Pressure	<input checked="" type="checkbox"/>	Process Temp						
<input checked="" type="checkbox"/>	Abs. Pressure										
<input checked="" type="checkbox"/>	Process Temp										
12	<p>The Solutions page presents itemized columns representing the data entered and the corresponding Wizard values that were calculated from the Wizard table data. Many of these values are used inside the SMV 3000 Multivariable Transmitter to compensate and calculate the flow for your application. Review the data to make sure the correct choices have been made based on your flow application.</p> <p>Click <i>Finish</i> to complete the Flow Compensation Wizard.</p>										
13	<p>Connect SCT to SMV and establish communications. (See subsection 5.2 for procedure, if necessary.)</p>										
14	<p>Perform Download of the database configuration file to the SMV.</p>										
15	<p>Use the procedure in subsection 7.5, <i>Using Transmitter to Simulate PV Input</i> to verify the flow calculation for this application. You can simulate inputs for PV1, PV2, and PV3 to verify PV4 output.</p>										

* Isentropic Exponent is also called the Ratio of Specific Heats.

C.3 Dynamic Compensation Flow Equation, Continued

SMV Operation in a Steam Application

When operating the SMV in a steam application there are number of considerations you should be aware of.

- Be sure the process is at or above saturation when operating the SMV, since the SMV does not calculate flow when the process is below saturation.
 - Operating limit for absolute pressure input is 750 psia(for Model SMV125), but SMV will continue to make calculations for inputs up to 1500 psia.
 - SMV Model SMG170 will operate and calculate to 3000 psig. At pressures greater than 2000 psia you must operate at less than 100 °F of saturation temperature.
 - Operating range for temperature input is saturation to 1500 °F (815.5 °C), assuming that the temperature sensor used (RTD or thermocouple) can cover this range, with the exception noted above.
-

Example: Superheated Steam

An engineer has specified a SMV 3000 Smart Multivariable Transmitter to dynamically compensate and calculate the mass flowrate of superheated steam through a standard 304 SS orifice meter with flange taps. The engineer has sized the orifice meter to produce a differential pressure of 241.3 inches H₂O at 22,345 lb/hr. The flowing pressure is 64.73 psia and the flowing temperature is 350 degrees F.

The steps in Table C-5 shows how to configure the SMV to calculate the PV4 flow variable for this application.

Continued on Next page

C.3 Dynamic Compensation Flow Equation, Continued

Table C-5 Superheated Steam Configuration Example

Step	Action								
1	<p>Select a template for the SMV 3000 model you have for your flow application.</p> <p>Select superheated steam mass flow in the Algorithm field of the FlowAlg tab and then select the Engineering Units (lb/h) on the FlowConf tab card.</p>								
2	<p>Click the Wizard . . . on the SCT/SMV 3000 configuration window to access the Flow Compensation Wizard Equation Model page.</p>								
3	<p>Select Dynamic Corrections from the list box on the Equation Model page of the Flow Compensation Wizard to invoke the Dynamic Flow Compensation Model, then click <i>Next</i> to proceed to the Flow Element Properties page.</p>								
4	<p>Enter the relevant information from the Orifice Sizing Data Sheet in each entry field of the Flow Element Properties page:</p> <table border="1" data-bbox="688 989 1341 1192"> <tr> <td>Element Type</td> <td>= Flange tap (D greater than 2.3 inches)</td> </tr> <tr> <td>Bore Diameter</td> <td>= 4.2154 inches</td> </tr> <tr> <td>Material</td> <td>= 304 SS</td> </tr> <tr> <td>Flowing Temperature</td> <td>= 350 °F</td> </tr> </table> <ul style="list-style-type: none"> The expansion coefficient is automatically calculated based on the entered data. <p>Click <i>Next</i> to proceed to the Fluid State page.</p>	Element Type	= Flange tap (D greater than 2.3 inches)	Bore Diameter	= 4.2154 inches	Material	= 304 SS	Flowing Temperature	= 350 °F
Element Type	= Flange tap (D greater than 2.3 inches)								
Bore Diameter	= 4.2154 inches								
Material	= 304 SS								
Flowing Temperature	= 350 °F								
5	<p>Select the fluid state as Steam from the list on the Fluid State page, then click <i>Next</i> to proceed to the Pipe Properties page.</p>								
6	<p>Enter the relevant information from the Orifice Sizing Data Sheet in each entry field of the Pipe Properties page:</p> <table border="1" data-bbox="688 1545 1198 1671"> <tr> <td>Pipe Schedule</td> <td>= 40s</td> </tr> <tr> <td>Nominal diameter</td> <td>= 10 inches</td> </tr> <tr> <td>Material</td> <td>= Carbon Steel</td> </tr> </table> <ul style="list-style-type: none"> The actual diameter and thermal expansion coefficient for the pipe are automatically calculated based on the entered data. <p>Click <i>Next</i> to proceed to the Discharge Coefficient page.</p>	Pipe Schedule	= 40s	Nominal diameter	= 10 inches	Material	= Carbon Steel		
Pipe Schedule	= 40s								
Nominal diameter	= 10 inches								
Material	= Carbon Steel								

Continued on Next page

C.3 Dynamic Compensation Flow Equation, Continued

Table C-5 Superheated Steam Configuration Example, continued

Step	Action						
7	<p>Enter the following lower and upper Reynolds number limits in each entry field of the Discharge Coefficient page. These values are used to clamp the discharge coefficient equation at these Reynolds numbers:</p> <table border="1" data-bbox="686 604 1055 684"> <tr> <td>Lower Limit</td> <td>= 200,000</td> </tr> <tr> <td>Upper Limit</td> <td>= 1,200,000</td> </tr> </table> <ul style="list-style-type: none"> Graph coordinates (Reynolds Number vs. Discharge Coefficient) will appear when the mouse is clicked on the graph. <p>Click <i>Next</i> to proceed to the Viscosity Compensation page.</p>	Lower Limit	= 200,000	Upper Limit	= 1,200,000		
Lower Limit	= 200,000						
Upper Limit	= 1,200,000						
8	<p>Enter the following equation order (order 4 is recommended) and temperature limits for the viscosity compensation in each entry field of the Viscosity Compensation page. The viscosity values will be clamped at the temperature limits.</p> <table border="1" data-bbox="686 1010 1055 1136"> <tr> <td>Order</td> <td>= 4</td> </tr> <tr> <td>Low Temp</td> <td>= 297</td> </tr> <tr> <td>High Temp</td> <td>= 400</td> </tr> </table> <p>Click <i>Yes</i> to refit the curve with the new limits.</p> <ul style="list-style-type: none"> Graph coordinates will appear when the mouse is clicked on the graph. <p>Click <i>Next</i> to proceed to the Density Variables page.</p>	Order	= 4	Low Temp	= 297	High Temp	= 400
Order	= 4						
Low Temp	= 297						
High Temp	= 400						
9	<p>Enter the relevant process information from the Orifice Sizing Data Sheet in each entry field of the Density Variables page.</p> <table border="1" data-bbox="686 1451 1102 1486"> <tr> <td>Isentropic Exponent *</td> <td>= 1.4044</td> </tr> </table> <p>Click <i>Next</i> to proceed to the Flowing Variables page.</p>	Isentropic Exponent *	= 1.4044				
Isentropic Exponent *	= 1.4044						

* Isentropic Exponent is also called the Ratio of Specific Heats.

Continued on next page

C.3 Dynamic Compensation Flow Equation, Continued

Table C-5 Superheated Steam Configuration Example, continued

Step	Action				
10	<p>Click on the following options for Failsafe Indication on the Flowing Variables page (so that there is an “✓” in each check box). It has been determined that the operator needs the flow output to go to failsafe when there is either a pressure or temperature failure (selecting Abs. Pressure and Process Temp. will assure this).</p> <table border="1" data-bbox="686 636 1055 716"> <tr> <td data-bbox="686 636 808 678">✓</td> <td data-bbox="808 636 1055 678">Abs. Pressure</td> </tr> <tr> <td data-bbox="686 678 808 716">✓</td> <td data-bbox="808 678 1055 716">Process Temp</td> </tr> </table> <ul style="list-style-type: none"> • Set damping for the flow output at 1.0 seconds. • Since Flow Failsafe has been selected for a pressure or temperature failure, the default values do not need to be set. If failsafe for the flow output is not needed when a pressure or temperature sensor fails, the default values for temperature and pressure are used in the flow calculation and the flowrate continues to be reported. <p>Click <i>Next</i> to proceed to the Solutions page.</p>	✓	Abs. Pressure	✓	Process Temp
✓	Abs. Pressure				
✓	Process Temp				
11	<p>The Solutions page presents itemized columns representing the data entered and the corresponding Wizard values that were calculated from the Wizard table data. Many of these values are used inside the SMV 3000 Multivariable Transmitter to compensate and calculate the flow for your application. Review the data to make sure the correct choices have been made based on your flow application.</p> <p>Click <i>Finish</i> to complete the Flow Compensation Wizard.</p>				
12	<p>Connect SCT to SMV and establish communications. (See subsection 5.2 for procedure, if necessary.)</p>				
13	<p>Perform Download of the database configuration file to the SMV.</p>				
14	<p>Use the procedure in subsection 7.5, <i>Using Transmitter to Simulate PV Input</i> to verify the flow calculation for this application. You can simulate inputs for PV1, PV2, and PV3 to verify PV4 output.</p>				

SMV 3000 Smart Multivariable Transmitter, Transmitter Models: SMA110, SMA125, SMG170

34-SM-99-01
03/04

**Addendum
(to User's Manual
34-SM-25-02)**

Overview

Replacement Meterbody and Heads

The SMV 3000 Multivariable Transmitter, all Models, is now being shipped with newly designed meter body and process heads. If a replacement meter body is needed, it should be ordered from the Model Number stated on the meter body nameplate. This number includes the letter "S" after the model number; for example, SMA110S-xxx.

This new transmitter is functionally identical to previous models in that the working ranges (Lower Range Limit to Upper Range Limit) and intended applications have not changed. However, the specifications for the maximum Pressure Rating and/or for the Overpressure Rating have been enhanced for some models. A summary of specifications is given in Table 6.

The new version, which will continue as SMV 3000, differs only in the physical size and form of the meter body, process head, and associated components.

With exceptions noted in this addendum, information given in 34-SM-25-02 SMV 3000 Multivariable Transmitter User's Manual applies also to this newer design.

Installation, operation, maintenance, calibration, and troubleshooting tasks remain virtually the same as for the previous version. Differences appear primarily in torque specifications when replacing meter bodies, and in part numbering and part recognition when replacing components or assemblies.

Related Publications

This addendum provides details for parts replacement for the new version of the SMV 3000 Smart Multivariable Flow Transmitter. For specific information regarding parts applicability, refer to the following publication.

34-SM-03-01

SMV 3000 Smart Multivariable Flow Transmitter
Specification and Model Selection Guide

Additions to the User Manual

The additions and changes to User Manual 34-SM-25-02 that relate to the newly designed meter body and process heads are given in Table 1 of this addendum.

Use the information in Table 1 to reference and annotate your User Manual.

Table 1 Additions/Changes to the User Manual

Page # in User Manual	Sub-Section	Description of Change
15	3.2 Considerations for SMV 3000 Transmitter Table 3 Transmitter Overpressure Ratings	The Maximum Working Pressure Rating and the Overpressure Rating has been enhanced for all models included in this addendum except for the draft range transmitter. For more information, refer to Table 1 in this Addendum.
28	4.5 Piping SMV 3000 Transmitter Table 6 Installing ½ inch NPT Flange Adapter	In Step 5 of Table 6, do not use the torque specification of 47.5 to 54 N•m(35 to 40 lb-ft). Instead, torque Flange Adapter bolts evenly to 47,5 N•m +/- 2,4 N•m (35 Lb-Ft +/- 1.8 Lb-Ft).
102	9.3 Inspecting and Cleaning Barrier Diaphragms Table 27 Inspecting and Cleaning Barrier Diaphragms	Do not use specifications for head bolt torque given In Step 8 of Table 27. Instead, torque head bolts/nuts to the specifications given in Table 2 of this addendum.
110	9.5 Replacing Meter Body Center Section Table 29 Replacing Meter Body Center Section	Do not use specifications for head bolt torque given In Step 9 of Table 29. Instead, torque head bolts/nuts to the specifications given in Table 2 of this addendum.
143	Replacement Parts Figure 32 SMV 3000 Meter Body Table 38 Parts Identification for Callouts in Figure 32	Figure 32 illustrates and Table 38 lists the replacement part available for the previous design of the transmitter. For the newer design, use Figure 1 of this addendum to locate parts, and use Table 3 of this addendum for part numbers and descriptions. For applicability of parts, refer to 34-SM-03-01 SMV 3000 Smart Multivariable Flow Transmitter Specification and Model Selection Guide
147	Wiring Diagrams and Installation Drawings	The numbers of installation drawings for transmitter models of revision S and greater is given in Table 7 of this addendum.

Table 2 Torque Table - Process Head Bolts/Nuts

Meterbody Type	Bolt Type		
	51452557-001 (Carbon Steel - standard; no option specified)	5142557-002 and -003 (NACE ["CR" option] and Non-NACE ["SS" option] Stainless Steel)	51452557-004 (B7M Alloy Steel ["B7" option])
51451864XXXX except ...XXX5 (See Note 1.)	67,8 N•M +/- 3,4 N•M (50.0 Lb-Ft +/- 2.5 Lb-Ft)	56,9 N•M +/- 2,8 N•M (42.0 Lb-Ft +/- 2.1 Lb-Ft)	48,8 N•M +/- 2,4 N•M (36.0 Lb-Ft +/- 1.8 Lb-Ft)

Note 1 – Part number 51451864XXX5 applies to the Meterbody for the STD 3000 Transmitter, Model STD110 (draft range).

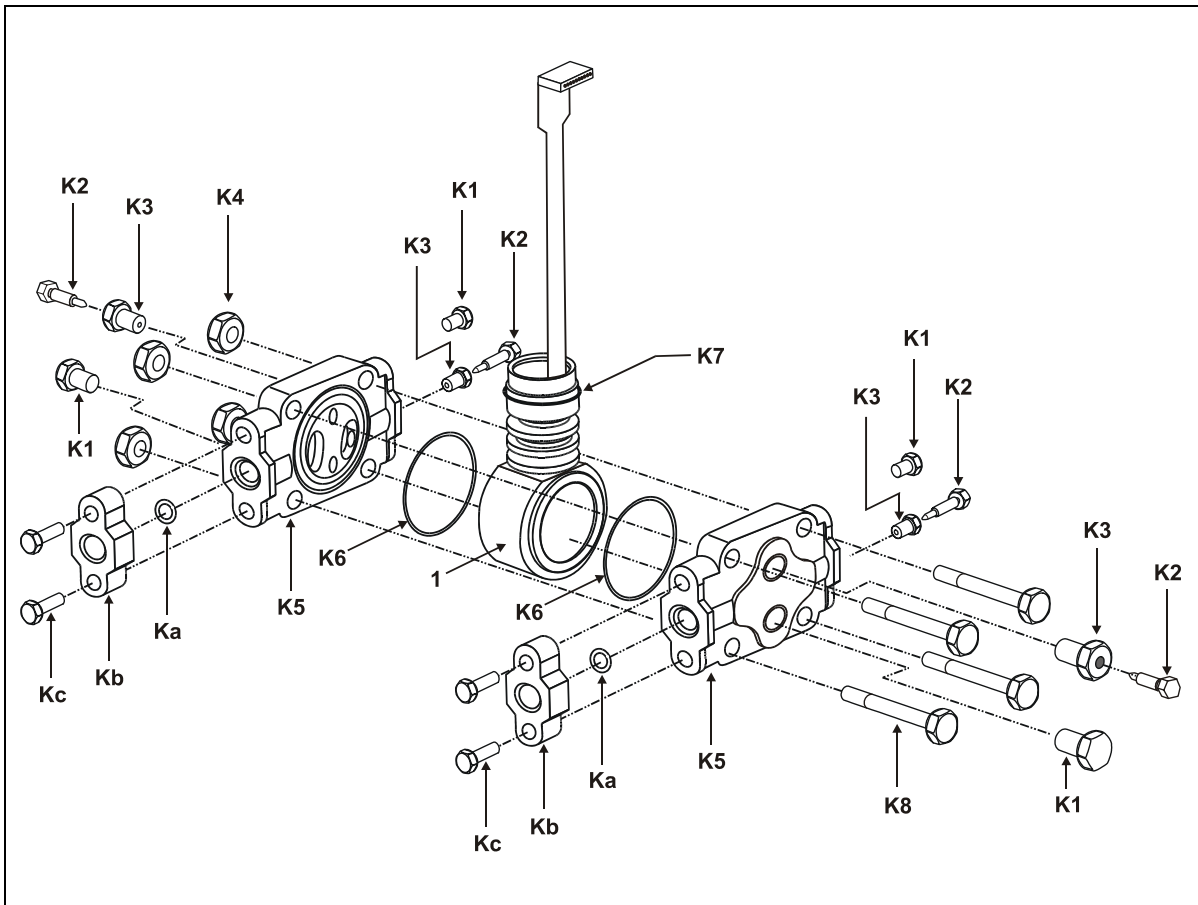

Figure 1 SMV 3000 Multivariable Transmitter – Meter Body and Process Heads (Rev S or greater)

Table 3 Parts Identification for Callouts in Figure 1

Key No.	Part Number	Description	Qty/ Unit
1	(Obtain the complete Model Number from the nameplate on the Meterbody)	Replacement Meterbody (without Heads)	1
Kc K4 K8	51452866-001 51452866-002 51452866-003 51452866-004	Bolts and Nuts Kit, Carbon Steel Bolts A286 SS (NACE) and Nuts, 304 SS (NACE) Kit Bolts, 316 SS (non-NACE) and Nuts, 316 SS (non-NACE) Kit Bolts B7M and Nuts 7M Kit Each Bolts and Nuts Kit includes: Bolt, Hex head, 7/16-20 UNF, 1.50 Inches long (Flange Adapter)..... Nut, Hex, 7/16 UNC (Process Head)..... Bolt, Hex Head, 7/16 UNC X 3.25 inches long (Process Head).....	4 4 4
K1 K2 K3	30753785-001 30753787-001 30753786-001	Drain and Plug Kit, stainless steel Drain and Plug Kit, Monel Drain and Plug Kit, Hastelloy C Each Drain and Plug Kit includes: Pipe Plug Vent Plug Vent Bushing	4 2 2
K6 Ka K7	51452865-001 51452865-002	Meterbody Gasket Kit (PTFE Material); Kit includes: Meterbody Gasket Kit (Viton Material); Kit includes: Gasket, Process Head Gasket, Flange Adapter O-Ring, Meterbody to Electronics Housing	6 6 3
K6 K6	51452868-001 51452868-002	Gasket only, Process Head (12 PTFE Gaskets/pack) Gasket only, Process Head (6 Viton Head O-Rings)	12 6
Ka Ka	51452868-004 51452868-005	Gasket only, Flange Adapter, 6 PTFE Adapter Gaskets Gasket only, Flange Adapter, 6 VITON Adapter O-Rings	6 6

Table 4 Flange Adapter Kits

Key No.	Part Number	Description	Quantity Per Unit
	51452867-110 51452867-210 51452867-310 51452867-410 51452867-150 51452867-350 51452867-130 51452867-330	Flange Adapter Kit, with: SS Flange Adapters and with carbon steel bolts SS Flange Adapters and with A286 SS (NACE) bolts SS Flange Adapters and with 316 SS (non-NACE) bolts SS Flange Adapters and with B7M alloy steel bolts Monel Flange Adapters and with carbon steel bolts Monel Flange Adapters and with 316 SS (non-NACE) bolts Hastelloy C Flange Adapters and with carbon steel bolts Hastelloy C Flange Adapters and with 316 SS (non-NACE) bolts Each 1/2-inch NPT Flange Adapter Kit includes: Gasket, Flange Adapter 1/2-inch NPT Flange Adapter Bolt, hex head, 7/16-20 UNF, 1.50 inches long, Flange Adapter ..	 2 2 4
Ka Kb Kc	SS Blind Flange Adapter Kit, with Carbon Steel bolts SS Blind Flange Adapter Kit, with A286 SS (NACE) bolts SS Blind Flange Adapter Kit, with 316 SS (non-NACE) bolts SS Blind Flange Adapters and B7M alloy steel bolts Each Blind Flange Adapter Kit includes: Gasket, Flange Adapter Blind Flange Adapter Bolt, hex head, 7/16-20 UNF, 1.50 inches long, Flange Adapter ..	 2 2 4

Table 5 Process Head Assembly Kits

Key No	Part Number	Description	Quantity Per Unit
	51452864-010	<u>Process Head Assembly Kit, with PTFE Gasket and with:</u> Carbon steel head (zinc plated) without side vent/drain	
	51452864-012	Carbon steel head (zinc plated) with side vent/drain	
	51452864-020	Stainless steel head without side vent/drain	
	51452864-022	Stainless steel head with side vent/drain	
	51452864-030	Hastelloy C head without side vent/drain	
	51452864-032	Hastelloy C head with side vent/drain	
	51452864-040	Monel head without side vent/drain	
	51452864-042	Monel head with side vent/drain	
		<u>Process Head Assembly Kit, with VITON Gasket and with:</u>	
	51452864-110	Carbon steel head (zinc plated) without side vent/drain	
	51452864-112	Carbon steel head (zinc plated) with side vent/drain	
	51452864-120	Stainless steel head without side vent/drain	
	51452864-122	Stainless steel head with side vent/drain	
	51452864-130	Hastelloy C head without side vent/drain	
	51452864-132	Hastelloy C head with side vent/drain	
	51452864-140	Monel head without side vent/drain	
	51452864-142	Monel head with side vent/drain	
		Each Process head Assembly Kit includes:	
K1	Pipe Plug (See Note.).....	2
K2	Vent Plug (See Note.).....	1
K3	Vent Bushing (See Note.).....	1
K5	Process Head	1
K6	Gasket (PTFE), Process Head	1
Ka	Gasket (PTFE), Flange Adapter.....	1
		NOTE: This item is made of the same material as the Process Heads, except for Kits with carbon steel Process Heads, which include stainless steel Pipe Plug, Vent Plug, and Vent Bushing.	

Table 6 Pressure Specification and Ratings Summary Comparisons

Transmitter Model	Upper Range Limit	Maximum Allowable Working Pressure (Note 1)	
		Previous	New Design
SMA 110	25 inches H ₂ O @ 39.2 F (differential pressure) 100 psia (absolute pressure)	100 psi (6.9 bar)	100 psi (6.9 bar)
SMA 125	400 inches H ₂ O @ 39.2 F (differential pressure) 750 psia (absolute pressure)	750 psi (51.7 bar)	750 psi (51.7 bar)
SMG 170	400 inches H ₂ O @ 39.2 F (differential pressure) 3000 psia (absolute pressure)	3000 psi (206.8 bar)	4500 psi (310.3 bar)

Note 1 Maximum Working Pressure Rating and Overpressure Rating may vary with materials of construction and with process temperature. For more specific information, refer to:

34-SM-03-01
SMV 3000 Smart Multivariable Flow Transmitter
Specification and Model Selection Guide.

Table 7 Dimension Drawings for Transmitter Models (Revision S or Greater)

For Mounting Transmitter on a...	Using Mounting Bracket Type...	See Drawing Number...
Vertical Pipe	Angle	50001091
Horizontal Pipe	Angle	50001092
Vertical Pipe	Flat	50001093
Horizontal Pipe	Flat	50001094

Index

A

Analog meter, 33
Analog mode, 4, 55, 81, 114
Angle mounting bracket, 20
Atmospheric Pressure Offset, 59, 85

B

Bad PV indication, 169
Barrier diaphragms, 101
 inspecting and cleaning, 101
Barriers, 31
Blow-down lines, 24, 27
Bracket mounted, 20
Bracket mounting, 21
 horizontal pipe, 21
 vertical pipe, 21

C

Calibration, 113
 Equipment Required, 113
 Output signal, 114
 Range (PV1 & PV2), 115
 Resetting to default values, 118
CE Conformity, 2, 29, 30
Center section, 108
 replace, 108
CJTACT Parameter, 163
Cold junction (CJ) compensation, 62
 Selecting Source, 62
Communications link, 150
Conduit seal, 36
Configuration database, 47, 77
 Saving, restoring, 98
Configuration files
 Saving, downloading and printing. *See also*
 Configuration database
Conversion factor (PV4), 74

D

Damping, 58, 60, 67, 72
DAMPING Parameter, 163
Database mismatch parameters, 164
DE configuration parameters, 51
DE protocol format, 4
DE_CONF Parameter, 162
Diagnostic messages, 121
 SCT display, 122
 SFC display, 122
Differential Pressure, 4
Digital (DE) mode, 5, 42
Digitally integrated, 32
Dimensions, 20
Dynamic compensation flow equation, 76
 Configuration Examples, 181

E

Electronics housing, 22
Electronics module, 95, 103
 replacing, 103
Engineering units
 Conversion (PV4), 167
 PV1 measurements, 54
 PV2 measurements, 59
 PV3 measurements, 61
 PV4 Custom units, 74
 PV4 measurements, 68
Engineering units conversion, 166
Environmental Conditions, 14
EUDESC Parameter, 160

F

Failsafe action, 95
Failsafe direction, 95
 change, 95
Failsafe jumper, 95
Flange adapter, 27
 installing, 27
Flat mounting bracket, 20
Flow compensation wizard, 49, 75, 175

G

Ground terminal, 31
Grounding, 31, 35

H

Hazardous locations, 36

L

Lightning protection, 35
Line Filter (PV3), 53
Loop resistance, 30
Loop wiring, 32
 non-intrinsically safe, 32
Low flow cutoff (PV4), 72
 limits, 72
LRV
 (PV1), 55
 (PV2), 60
 (PV3), 65, 66
 (PV4), 70, 71

Index

M

Maintenance routines, *100*
Meter body temperature, *5*
Mounting locations
 suggested, *25*

O

Operating Modes, *4*
Operation data, *92*
Output conformity (PV1), *56*
Output Linearization (PV3), *62*
Output meter, *32*
Overpressure rating, *15*

P

Parts identification, *137*
PIUOTDCF Parameter, *163*
Platinum 100 ohm (RTD), *16, 63*
PM/APM/HPM SMV 3000 Integration, *150*
PM/SMV 3000 Integration
 Configuration, *159*
 Data exchange functions, *152*
 Detail display, *164*
 Hierarchy, *151*
 Number of PVs, *155*
 STITAG parameter, *154*
Potential Noise Sources, *14*
Power supply voltage, *30*
Primary flow elements, *75*
Process Characteristics, *14*
PROM, *103*
 Identification, *103*
 replacing, *103*
PV Type, *51*
PV1 Priority, *50*
PVCHAR Parameter, *161*

R

Recommended spare parts, *137*
Request/response format, *7*
RTD leads, *31*

S

SCT 3000, *6, 17, 38, 77*
 Flow compensation wizard, *75*
 For SMV configuration, *47, 49*
 On-line connections, *40*
 On-line help, *46*
Secondary variable, *4, 5*
SECVAR field, *168*
Sensor type (PV3)
 identifying, *63*
 Identifying, *16*
SENSRTYP Parameter, *161*
SFC, *7, 8, 48*
SFC Communications, *7*

S, cont'd

Smart Field Communicator. See SFC
Smartline Configuration Toolkit. See SCT 3000
Smartline Option Module, *39*
SMV 3000
 Software version, *1, 46*
SMV Configuration using SCT 3000, *49*
Span
 (PV1), *55*
 (PV2), *60*
 (PV3), *65*
 (PV4), *71*
Square root dropout (PV1), *57*
Square root output (PV1), *56*
Standard flow equation, *75*
 Configuration Examples, *176*
Start-up, *80*
 Flow measurement application, *86*
 Tasks, *12*
Static discharge damage, *95, 105*
Steam calculation facts, *188*
STI_EU Parameter, *161*
STIMV IOP module, *1, 52, 95, 150*
STIMV IOP status messages, *169*
STITAG Parameter, *154, 160*

T

T/C Fault Detect (PV3), *64*
Tag ID, *50*
Temperature limits-transmitter, *15*
Thermocouple leads, *31*
Thermocouple types, *16, 63*
Thermowell, *29*
 installing, *29*
Three-valve manifold, *24*
Transmitter
 Configuration in a TDC system, *159*
 Flow application verification, *78, 84*
 Input mode, *84*
 Integration with TDC, *149*
 Output mode, *81, 114*
Transmitter order, *9*
Turndown Ratio, *58*

U

Upper Range Limit (URL), *15*
URL Parameter, *162*
URV
 (PV1), *55*
 (PV2), *60*
 (PV3), *65, 66*
 (PV4), *70, 71*

Index

V

Valve Cavitation, *14*
Verify Flow Configuration, *78*
Vibration Sources, *14*

W

Wiring
 Loop/power, *32*

 Optional analog meter, *33*
 Temperature sensor input, *33*
Write protect option, *43*
 Jumper, *43*

Z

Zero shift, *23*

Honeywell

Industrial Automation and Control

Honeywell Inc.

16404 N. Black Canyon

Phoenix, Arizona 85023