

# LAND



## **LANDSCAN**

### LSP Series Linescanners

### Mountings and Accessories



An **AMETEK**® Company

# LANDSCAN LSP RANGE OF MOUNTINGS AND ACCESSORIES

The following information is intended as a guide to the extensive range of optional mountings and accessories available to ensure that you get the best possible service from the investment you have made when specifying Landscan LSP infrared linescanning systems to monitor and control your manufacturing process. The tables below illustrate a range of possible arrangements for typical industrial applications encountered - ranging from light industrial to hostile environments such as the steel and glass works.

For specific recommendations on the choice of protection housing, mounting assemblies, water cooling, air purging and cabling requirements to suit your specific industry or installation, contact Land Instruments International for further advice before ordering.

## TYPICAL APPLICATIONS

### Light Industrial - General Purpose

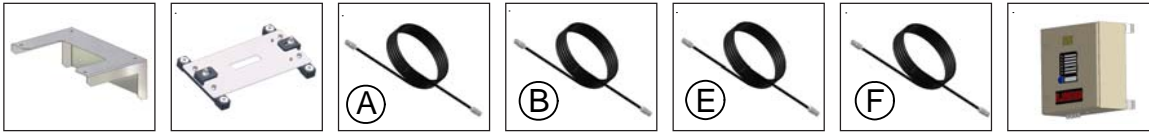

### Heavy Industrial - Hostile Environments

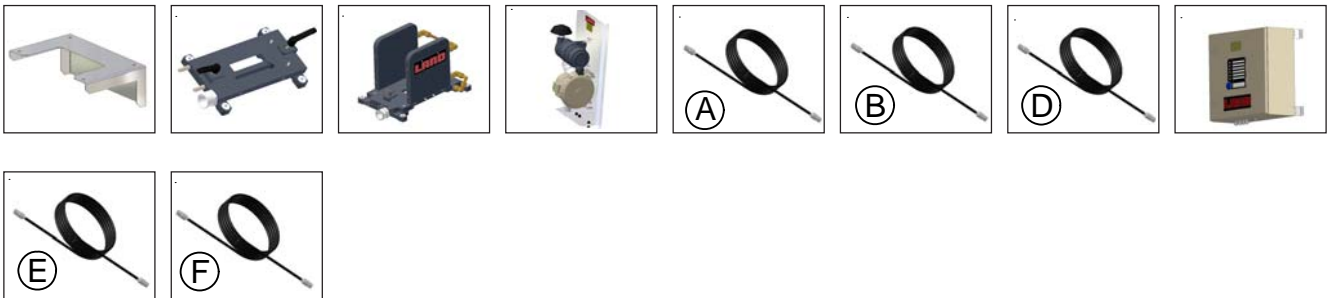

## SPECIAL APPLICATIONS

### Glass Float Line

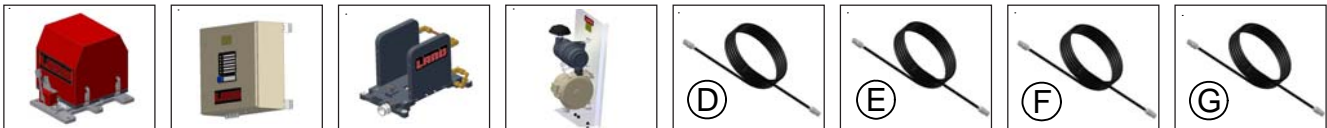

Other examples include: kiln scanning, and torpedo car and ladle safety, and conveyor belt monitoring. For information on these applications contact Land Instruments International for further information.

### KEY



Right-angle  
Mounting plate



Water-cooled, air  
purged base plate



Float line mounting  
assembly with cover



Float line mounting  
service panel



Cable assemblies  
See separate table



Basic Mounting  
Plate



Water-cooled,  
air purged base  
plate with sides



Plate mounted  
blower unit



Mini service  
panel

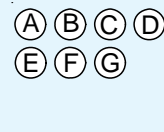

A B C D  
E F G

## RIGHT ANGLE MOUNTING PLATE

The right angle mounting plate is a simple design intended for basic LSP linescanner head mounting.

It is pre-drilled to accept either the basic mounting plate or the water cooled, air purged base plate.

All fixings are supplied with the plate.

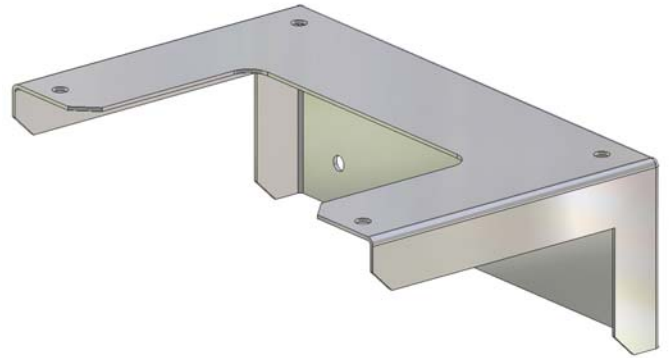

Can be used with:

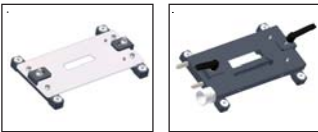

### Right angle mounting plate

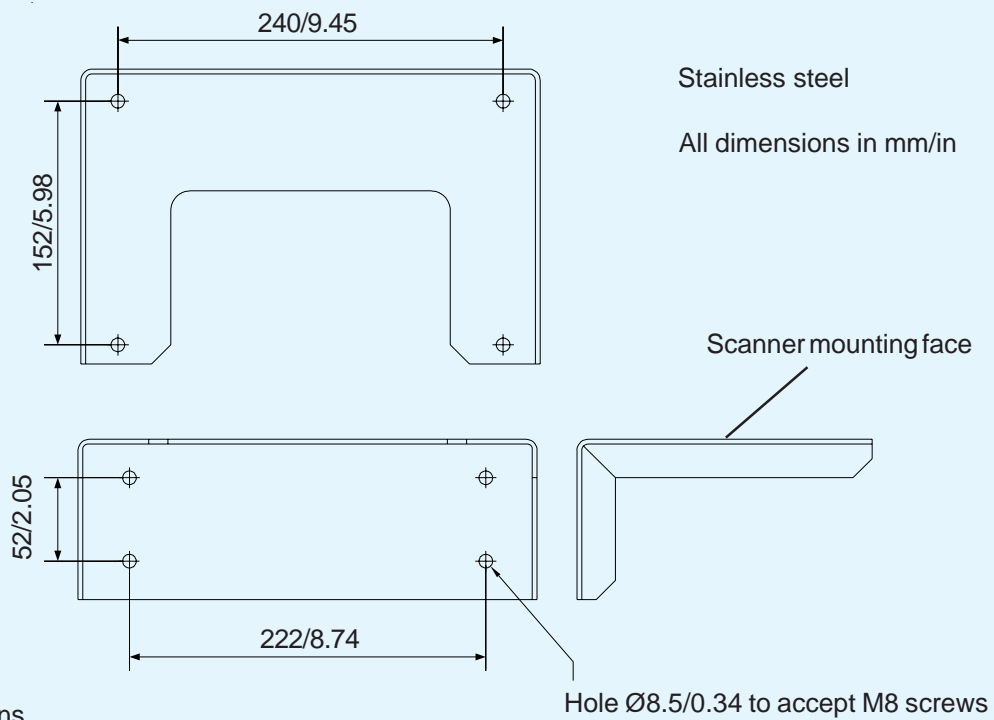

## BASIC MOUNTING PLATE

The basic base plate is used in applications where an LSP linescanner head is to be installed in light industrial environments where the ambient temperatures is within the recommended operating range of the instrument and the atmosphere is relatively free from dust and airborne particles.

The basic base plate provides a quick release mounting arrangement for the scanner, making realignment a simple and easy operation.

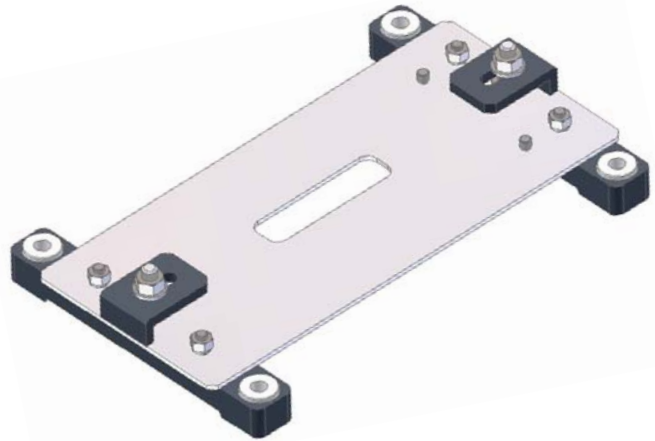

Can be used with:



### Basic mounting plate

All dimensions in mm/in

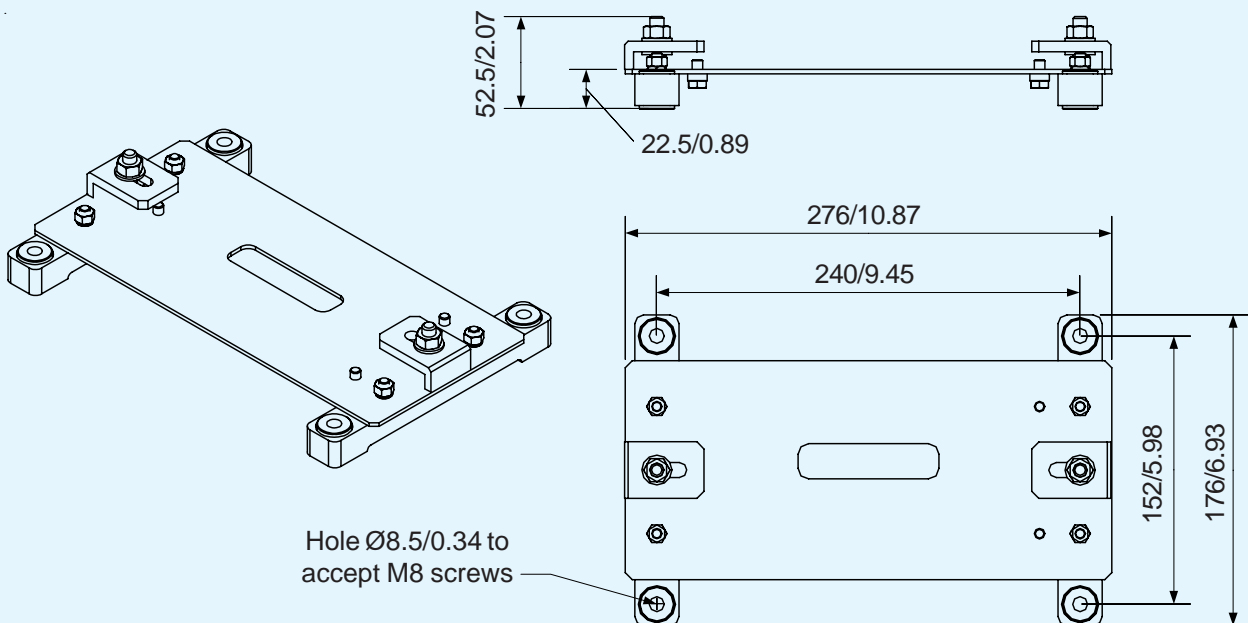

## WATER COOLED, AIR PURGED BASE PLATE

The water cooled, air purged base plate is used in applications where an LSP scanner is to be installed into environments where the ambient temperatures are in the range of 60 to 100°C/140 to 212°F.

This accessory is ideally suited to general industrial applications.

The air purge facility should be utilized where the operating environment is dusty and airborne particles could contaminate the scanner viewing window.

The base plate is fitted with hose connectors suitable for 9.5mm/3/8in bore reinforced PVC water hose.

The water flow rate required depends upon each individual application, however 1l/min/0.26GPM is an absolute minimum at 30°C/86°F maximum water temperature.

The base plate is fitted with a G3/8 air connector, which is suitable for 38mm/1.5in I/D neoprene air hose, through which the purge air is supplied.

The flow rate depends upon local conditions and scanner orientation, but a rate of 300l/min/12.36SCFM at an inlet pressure of 1m WG/1.42psi/0.1bar is typically sufficient.

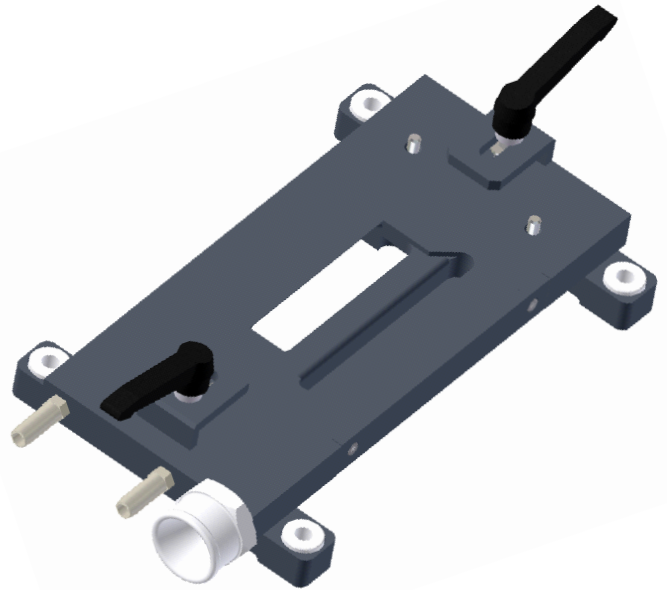

Can be used with:

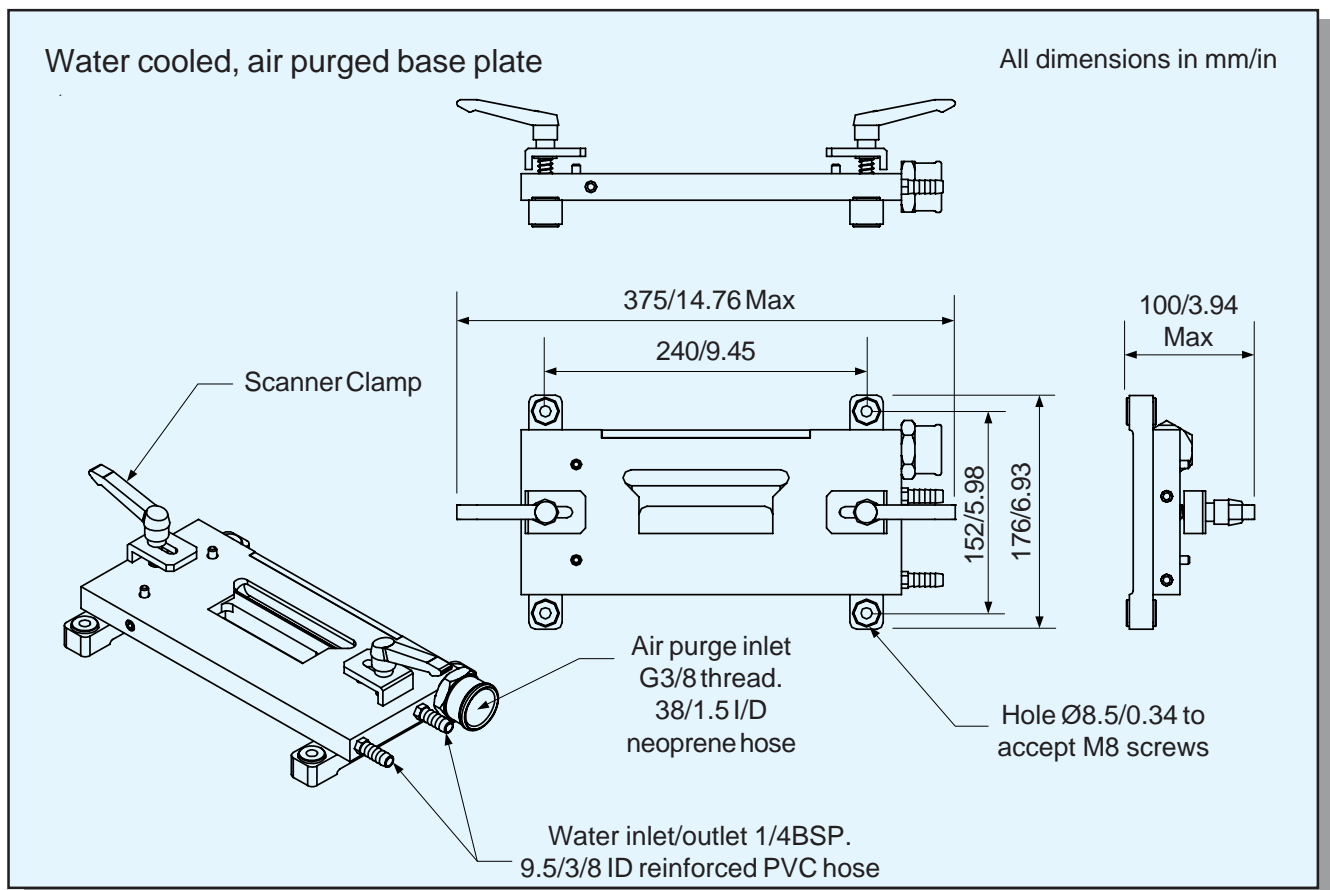

## WATER COOLED, AIR PURGED BASE PLATE WITH SIDES

The water cooled, air purged base plate with sides is used in applications where an LSP linescanner is to be installed in environments where the ambient temperatures are in the range of 60 to 120°C/140 to 212°F, such as steel and glass plants.

The air purge facility should be utilized where the operating environment is dusty and airborne particles could contaminate the scanner viewing window.

The base plate is fitted with hose connectors suitable for 9.5mm/3/8in bore reinforced PVC water hose.

The water flow rate required depends upon each individual application, however 1l/min/0.26GPM is an absolute minimum at 30°C/86°F maximum water temperature.

The base plate is fitted with a G3/8 air connector, which is suitable for 38mm/1.5in I/D neoprene air hose, through which the purge air is supplied.

The flow rate depends upon local conditions and scanner orientation, but a rate of 300l/min/12.36SCFM at an inlet pressure of 1m WG/1.42psi/0.1bar is typically sufficient.



### Water cooled, air purged base plate with sides

All dimensions in mm/in

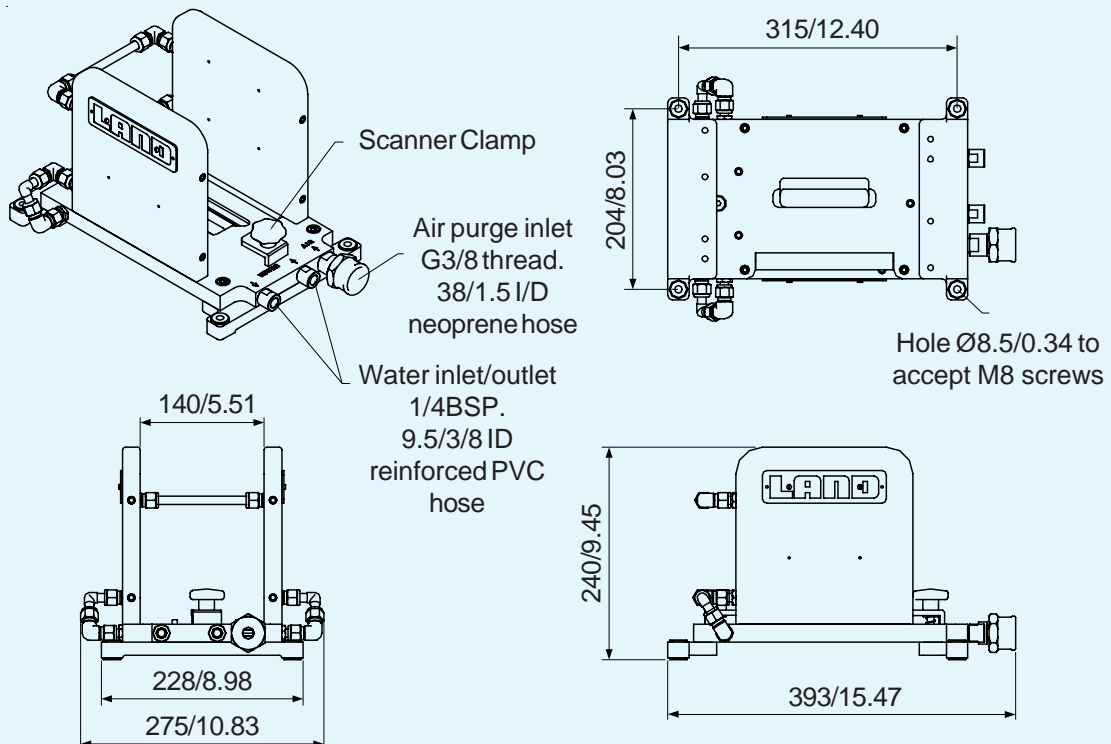

## LSP FLOATLINE MOUNTINGS

LSP float line mountings provide protection for the LSP linecanner, against high ambient temperatures and heavy contamination associated with glass float line environments.

They also give flexibility for alignment when setting up and rigidity and adjustability during scanner mounting.

To counter high ambient temperatures, a water-cooling system is employed.

This requires a constant, clean water supply to be available. The cooling water flows through the side and base plates and is supplied via 1/4in BSP inflow and outflow connectors, suitable for 9.5mm/3/8in bore reinforced PVC water hose.

The water flow rate required depends upon each individual application, however 1l/min/0.26GPM is an absolute minimum at 30°C/86°F maximum water temperature.

An air purge system is also utilized to protect the scanner from contamination and the hostilities of the process under observation.

A G3/8 air connector in the mounting plate accommodates 38mm/1.5in I/D neoprene air hose, through which the purge air is supplied. The flow rate depends upon local conditions and scanner orientation, but a rate of 300l/min/12.36SCFM at an inlet pressure of 1m WG/1.42psi/0.1bar is typically sufficient.

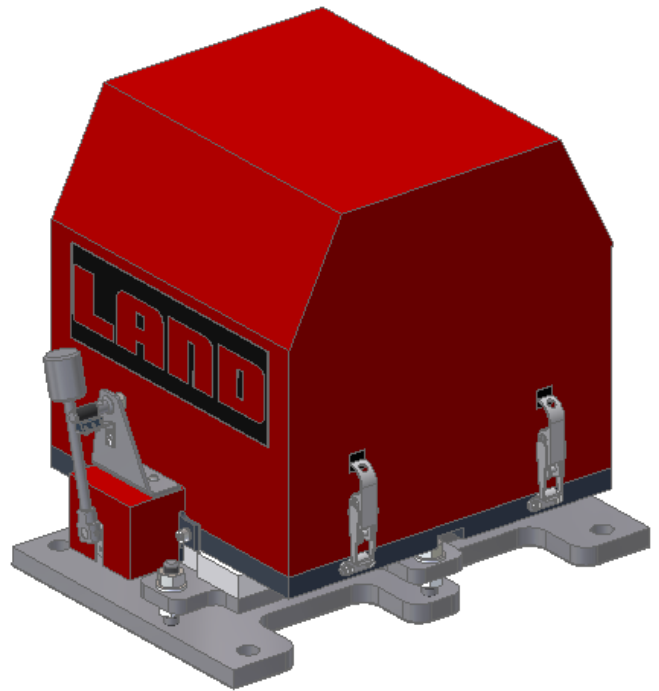

### LSP float line mounting assembly

All dimensions in mm/in

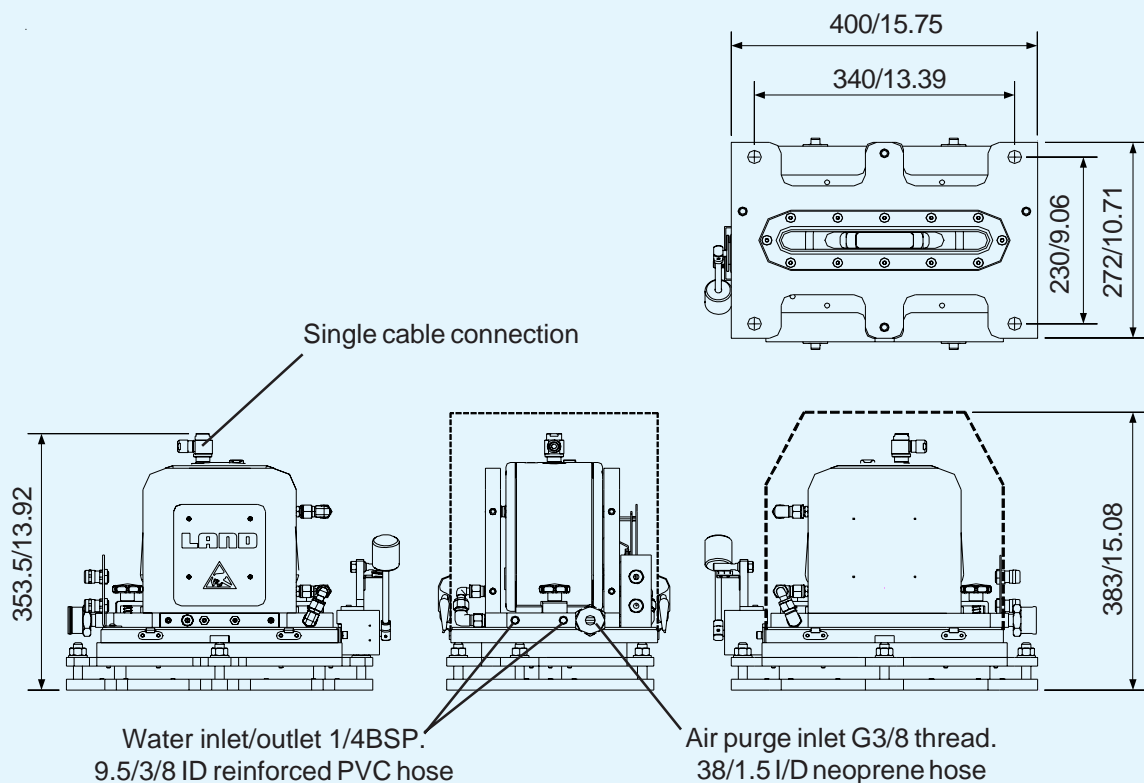



## LSP FLOATLINE SYSTEM SERVICE PANEL

The LSP linescanner float line system service panel provides mains power to all components of the LSP system, isolation facilities for servicing access and real-time system status information.

The display panel can be supplied with a choice of languages to suit the local application.

It provides a real-time indication of system status, including:

**Power On (24V)** - status indication

**Over Temperature** - warning indication

**Low Purge Pressure** - warning indication

**High Purge Pressure** - warning indication

**Shutter Not Open** - status indication

**Manual Close** - status indication

**Push For Manual Close** - manual operation

Any chosen installation site for the service panel must have low vibration, low contamination and must be within ambient temperature specification at all times (max. 50°C/90°F).

The maximum cable run between the service panel installation site and the float line mountings should not exceed 15m/50ft, taking into account the safe routing of the cable.



LSP float line system service panel

All dimensions in mm/in

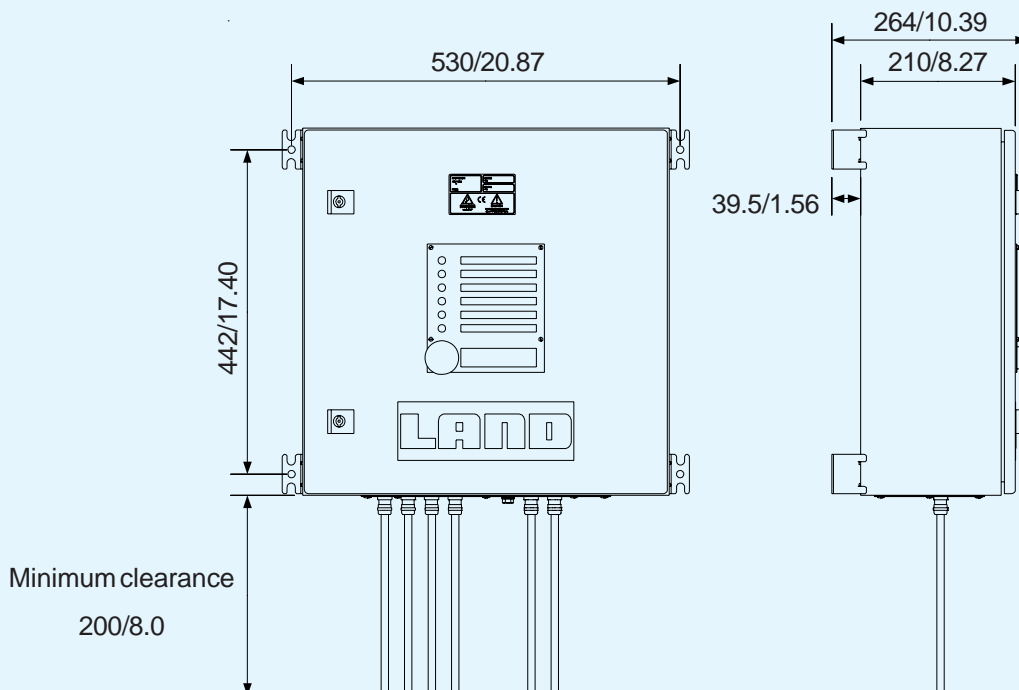



## LSP MINI SERVICES PANEL

The LSP Mini Services Panel provides mains power to all components of the LSP system, isolation facilities for servicing access and system status information. It is primarily utilized when a cable extension is required, allowing up to 300m/1000ft of additional cable run from initial 15m/50ft installation point.

Any chosen installation site for the service panel must have low vibration, low contamination and must be within ambient temperature specification at all times (max. 50°C/122°F).

The maximum cable run between the mini services panel installation site and the LSP must not exceed 15m/50ft, taking into account the safe routing of the cable.



### LSP MINI SERVICES PANEL

All dimensions in mm/in

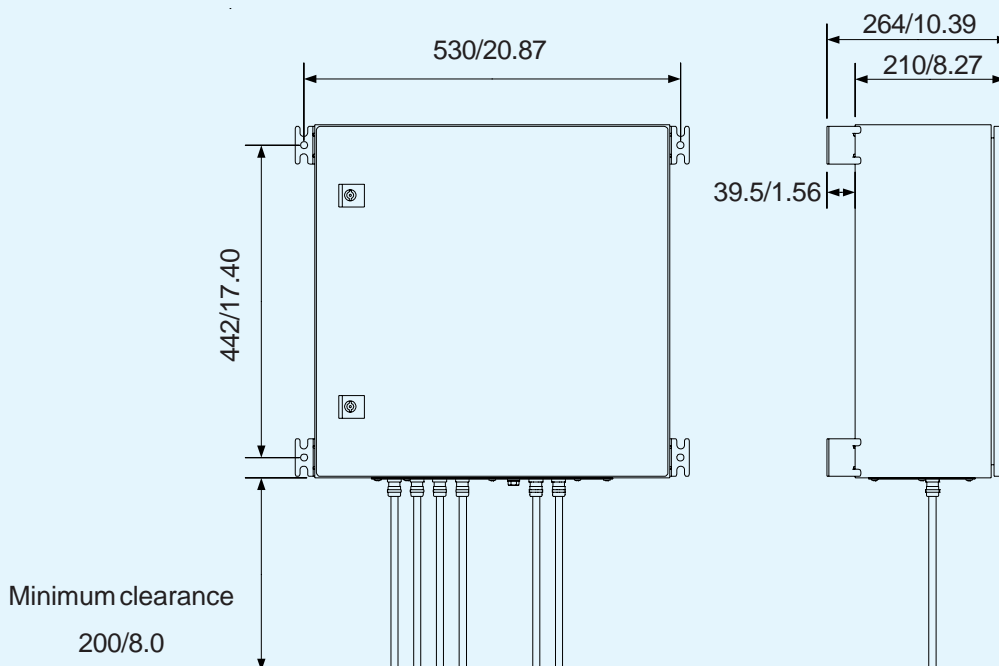

## PLATE MOUNTED BLOWER UNIT

The plate mounted blower unit provides air to linescanning and thermal systems, where the specified application requires a controlled, conditioned air source for instrument cooling and/or optical air purging in order to maintain a clear sight path to the target. Optional weatherproof cover available.

### Specifications

	Option 1	Option 2	Option 3
Power supply:	230V a.c.	110V a.c.	220V a.c.
Frequency:	50Hz	60Hz	60Hz
Power consumption:	400W	500W	500W
Circuit breaker (type C):	10A	16A	10A

Operating temperature: -20 to 50°C/-4 to 122°F (-40 to 50°C/-40 to 122°F with optional air heater fitted)

Environmental rating: IP55/NEMA 4 (IP55/NEMA 4X (with weatherproof cover fitted))

CE marking: 89/336/CEE; 73/23/CEE

Weather proofing: In accordance with EN 60034-5

### Plate mounted blower unit

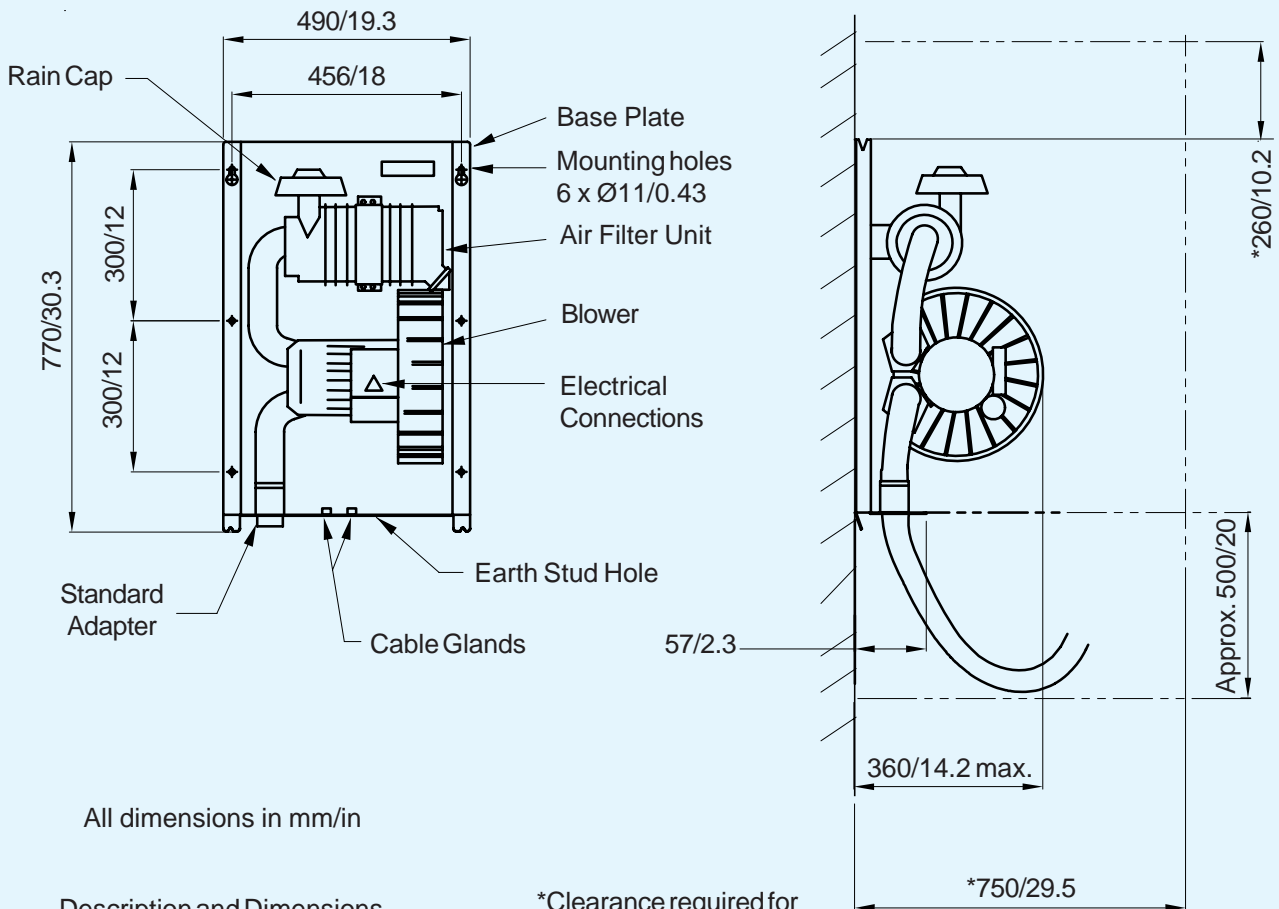

Description and Dimensions

\*Clearance required for fitting weatherproof cover

## RECOMMENDED CABLE ASSEMBLIES

The following cabling schedules are intended to provide a guide to recommended cable arrangements for typical industrial applications encountered. For specific recommendations on your application contact Land Instruments International for further advice before ordering.

Light Industrial - General Purpose				
Key	Connection	Cable Length	Description	Part Number
(A)	LSP to LSC-B/C	up to 15m/50ft	Standard cable	031-402
(B)	LSP to LSC-B	15m/50ft to 150m/500ft	Special order cable	N/A
(A)	LSP to LSC-B/C	150m/500ft to 300m/1000ft	Standard cable	031-402
(E)			+ Mini service panel	ZT7198
(F)			+ Belden 8162 (2-pair) or Belden 8163 (3-pair)	203-849  203-852

Heavy Industrial - Hostile Environments				
Key	Connection	Cable Length	Description	Part Number
(A)	LSP to LSC-B/C	up to 15m/50ft	Standard cable	031-402
(D)			or High temperature cable	031-794
(B)	LSP to LSC-B	15m/50ft to 150m/500ft	Special order cable	N/A
(D)			or High temperature cable	031-794
(E)		All lengths	+ Mini service panel	ZT7198
(F)		All lengths	+ Belden 8162 (2-pair) or Belden 8163 (3-pair)	203-849  203-852

Glass Float Line Applications				
Key	Connection	Cable Length	Description	Part Number
(D)	LSP to LSC-B/C	all lengths	High temperature cable	031-794/795
(E)			+ Float line service panel	092-733
(F)			+ Data cable - Belden 8162 (2-pair)	ZT7198 203-849
(G)			+ Belden 8163 (3-pair) + Service cable - Belden 8777 (3-pair) min.	203-852  203-891

For further information please contact the appropriate office or visit our web site at: [www.landinst.com](http://www.landinst.com)

**Land Instruments International**

**Infrared Temperature Measurement**

Dronfield S18 1DJ, England  
Telephone: (01246) 417691  
Facsimile: (01246) 410585  
Email: [infrared.sales@landinst.com](mailto:infrared.sales@landinst.com)  
Internet: [www.landinst.com](http://www.landinst.com)

**Land Instruments Sarl**

**Infrared Temperature Measurement**

7 Parc des Fontenelles  
78870 Bailly, France  
Téléphone: (1) 34 62 05 45  
Télécopie: (1) 30 56 51 12  
Email: [commercial@landinst.fr](mailto:commercial@landinst.fr)  
Internet: [www.landinst.fr](http://www.landinst.fr)

**Land Instruments GmbH**

**Infrared Temperature Measurement**

Fixheider Str. 6  
51381 Leverkusen, Germany  
Telefon: 02171/7673-0  
Telefax: 02171/7673-9  
Email: [infrarot@landinst.de](mailto:infrarot@landinst.de)  
Internet: [www.landinst.de](http://www.landinst.de)

**Land Instruments Srl**

**Infrared Temperature Measurement**

Via dell'Industria, 2  
20037 Paderno Dugnano,  
Milano, Italy  
Telefono: 02/99040423  
Telefax: 02/99040418  
Email: [info@landinst.it](mailto:info@landinst.it)  
Internet: [www.landinst.it](http://www.landinst.it)

**Land Instruments Ltd**

31-27 Toyotsuchou, Suita  
Osaka 564-0051, Japan  
Telephone: 06 6330 5153  
Facsimile: 06 6330 5338  
Email: [info@landinst.jp](mailto:info@landinst.jp)  
Internet: [www.landinst.jp](http://www.landinst.jp)

**Land Instruments International**

Av. Horacio 1132 Planta Baja "B"  
Col. Polanco  
11550 Mexico, D.F.  
Telephone: 52 55 5281 1165  
Facsimile: 52 55 5281 5364  
Email: [ventas@landinstruments.net](mailto:ventas@landinstruments.net)  
Internet: [www.landinstruments.net](http://www.landinstruments.net)

**Land Instruments International**

**Infrared Temperature Measurement**

Chile, 10-Edificio Madrid 92  
28290 Las Matas, Madrid, Spain  
Telephone: 91 630 0791  
Facsimile: 91 630 2918  
Email: [land-infrared@landinst.es](mailto:land-infrared@landinst.es)  
Internet: [www.landinst.es](http://www.landinst.es)

**AMETEK Land, Inc.**

**Infrared Temperature Measurement**

10 Friends Lane  
Newtown, PA 18940-1804, USA  
Telephone: (215) 504-8000  
Facsimile: (215) 504-0879  
Email: [irsales@landinstruments.net](mailto:irsales@landinstruments.net)  
Internet: [www.landinstruments.net](http://www.landinstruments.net)

Distributor:

# LAND

An **AMETEK**® Company



0034

