

# Ultrasonic Transmitters

SITRANS Probe LU (HART)

Quick Start Manual • 12/2013



SITRANS

**SIEMENS**



# SITRANS Probe LU Quick Start Manual

This manual outlines the essential features and functions of SITRANS Probe LU. We strongly advise you to acquire the detailed version of the manual so you can use your instrument to its fullest potential. The complete manual is available on our website at: [www.siemens.com/probelu](http://www.siemens.com/probelu). The printed manual is available from your local Siemens representative.

Questions about the contents of this manual can be directed to:

Siemens Milltronics Process Instruments  
1954 Technology Drive, P.O. Box 4225  
Peterborough, Ontario, Canada, K9J 7B1  
Email: [techpubs.smpi@siemens.com](mailto:techpubs.smpi@siemens.com)

**Copyright Siemens Milltronics  
Process Instruments 2013.  
All Rights Reserved**

## Disclaimer of Liability

We encourage users to purchase authorized bound manuals, or to view electronic versions as designed and authored by Siemens Milltronics Process Instruments. Siemens Milltronics Process Instruments will not be responsible for the contents of partial or whole reproductions of either bound or electronic versions.

While we have verified the contents of this manual for agreement with the instrumentation described, variations remain possible. Thus we cannot guarantee full agreement. The contents of this manual are regularly reviewed and corrections are included in subsequent editions. We welcome all suggestions for improvement.

Technical data subject to change.

MILLTRONICS is a registered trademark of Siemens Milltronics Process Instruments

## Safety Guidelines

Warning notices must be observed to ensure personal safety as well as that of others, and to protect the product and the connected equipment. These warning notices are accompanied by a clarification of the level of caution to be observed.



**WARNING:** relates to a caution symbol on the product, and means that failure to observe the necessary precautions can result in death, serious injury, and/or considerable material damage.



**WARNING<sup>1</sup>:** means that failure to observe the necessary precautions can result in death, serious injury, and/or considerable material damage.

**Note:** means important information about the product or that part of the operating manual.

<sup>1</sup> This warning symbol is used when there is no corresponding caution symbol on the product.

# SITRANS Probe LU

**! WARNING: Changes or modifications not expressly approved by Siemens could void the user's authority to operate the equipment.**

## Notes:

- SITRANS Probe LU is to be used only in the manner outlined in this manual, otherwise protection provided by the equipment may be impaired.
- This product is intended for use in industrial areas. Operation of this equipment in a residential area may cause interference to several frequency based communications.

SITRANS Probe LU is a loop-powered continuous level monitor, using advanced ultrasonic techniques. The unit consists of an electronic component coupled to the transducer and process connection.

The transducer is available in ETFE (ethylene-tetrafluoroethylene) or PVDF (polyvinylidene fluoride), allowing SITRANS Probe LU to be used in a wide variety of industries and applications using corrosive chemicals.

The ultrasonic transducer contains a temperature sensing element to compensate for temperature changes in the application.

Communication is via HART<sup>1</sup>, and signals are processed using Sonic Intelligence<sup>®</sup>.

## Specifications

For a complete listing, see the SITRANS Probe LU Instruction Manual. For Approvals information, please refer to the device nameplate.

## Ambient/Operating Temperature

**Note:** Process temperature and pressure capabilities are dependent upon information on the product nameplate. The reference drawing listed on the nameplate can be downloaded from the Siemens website. Go to the product page at: [www.siemens.com/probelu](http://www.siemens.com/probelu).

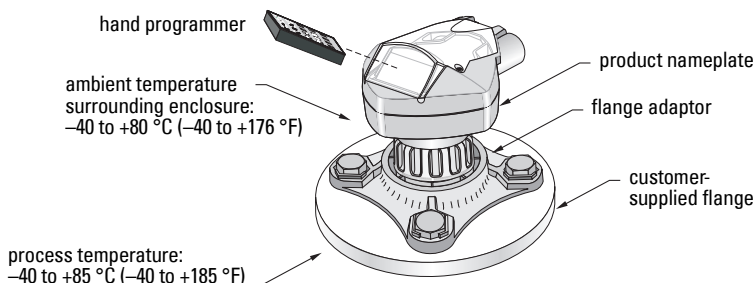

<sup>1</sup>. HART<sup>®</sup> is a registered trademark of the HART Communication Foundation.

## Power

Nominal 24 V DC at max. 550 Ohm: for other configurations see the full manual.

- Maximum 30 V DC
- 4 to 20 mA

## Approvals

- General: CSA<sub>US/C</sub>, FM, CE
- Hazardous: Intrinsically Safe (Europe) ATEX II 1 G Ex ia IIC T4 Ga  
(US/Canada) FM/CSA: (barrier required)<sup>1</sup>  
Class I, Div. 1, Groups A, B, C, D  
Class II, Div. 1, Groups E, F, G  
Class III T4  
(International) IECEx SIR 13.0008X Ex ia IIC T4 Ga  
(Brazil) INMETRO DNV 12.0070 X  
Ex ia IIC T4 Ga  
IP67/IP68  
-40 °C ≤ Ta ≤ +80 °C  
DNV #OCP 0017  
ABNT NBR IEC 60079-0:2008  
ABNT NBR IEC 60079-11:2009 e  
ABNT NBR IEC 60079-26:2008
- Non-incendive (US) FM:<sup>2</sup>  
Class I, Div. 2, Groups A, B, C, D T5
- Marine Lloyd's Register of Shipping  
ABS Type Approval

**Note:** Approved dust-tight and water-tight conduit seals are required for outdoor Type 4X / NEMA 4X, Type 6 / NEMA 6, IP67, IP68 locations.

<sup>1</sup> See *FM Intrinsically safe connection drawing* on page 1 of Appendix A, for reference drawing 23650516, or *CSA Intrinsically Safe connection drawing* on page 2 of Appendix A, for reference drawing 23650517.

<sup>2</sup> See *FM Class I, Div. 2 connection drawing* on page 3 of Appendix A, for reference drawing 23650583.

# Installation



## ! WARNINGS:

- **Materials of construction are chosen based on their chemical compatibility (or inertness) for general purposes. For exposure to specific environments, check with chemical compatibility charts before installing.**
- **This product can only function properly and safely if it is correctly transported, stored, installed, set up, operated, and maintained.**
- **The user is responsible for the selection of bolting and gasket materials which will fall within the limits of the flange and its intended use, and which are suitable for the service conditions.**

**Note:** Installation shall only be performed by qualified personnel and in accordance with local governing regulations.

## Mounting Location

Recommendations:

- Ambient temperature within  $-40$  to  $+80$  °C ( $-40$  to  $+176$  °F).
- Easy access for viewing the display and programming via the hand programmer.
- An environment suitable to the housing rating and materials of construction.
- Keep the sound path perpendicular to the material surface.

Precautions:

- Avoid proximity to high voltage or current wiring, high voltage or current contacts, and to variable frequency motor speed controllers.
- Avoid interference to the sound path from obstructions or from the fill path.

The sound path should be:

- perpendicular to the monitored surface
- clear of rough walls, seams, rungs, or other obstructions
- clear of the fill path

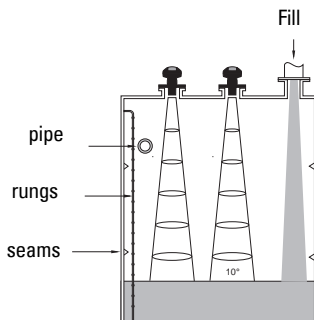
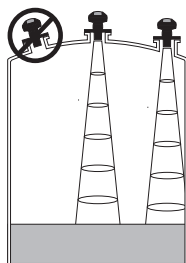

# Mounting Instructions

**Note:** Ideally, mount SITRANS Probe LU so that the face of the transducer is at least 300 mm (1 ft) above the highest anticipated level.

SITRANS Probe LU is available in three thread types: 2" NPT, 2" BSP, or PF2/G.

1. Before inserting SITRANS Probe LU into its mounting connection, ensure that the threads are of the same type to avoid damaging them.
2. Simply screw SITRANS Probe LU into the process connection, and hand tighten.

## Wiring

### Power

#### WARNINGS:



DC terminals shall be supplied from an SELV<sup>1</sup> source in accordance with IEC-1010-1 Annex H.



All field wiring must have insulation suitable for rated voltages.

## Connecting SITRANS Probe LU

#### Notes:

- For detailed information on Intrinsically Safe set-ups, please see the full manual.
- Use shielded, twisted pair cable (wire gauge AWG 22 to AWG 14 / 0.34 mm<sup>2</sup> to 2.08 mm<sup>2</sup>).
- Separate cables and conduits may be required to conform to standard instrumentation wiring practices, or electrical codes.
- The non-metallic enclosure does not provide a continuous ground path between conduit connections: use grounding-type bushings and jumpers.

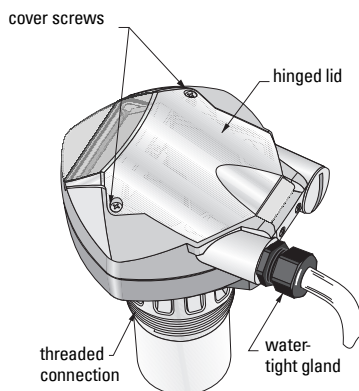

<sup>1</sup>. Safety Extra Low Voltage

- Strip the cable jacket for approximately 70 mm (2.75") from the end of the cable, and thread the wires through the gland<sup>1</sup>.
- Connect the wires to the terminals as shown above: the polarity is identified on the terminal block.
- Tighten the gland to form a good seal.
- Close the cover and tighten screws: **please do not overtighten screws**. Recommended torque is 1.1 to 1.7 N-m (10 to 15 in-lb).

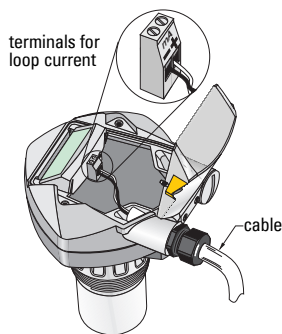

## Wiring setups for hazardous area installations

Always check the device nameplate and process device tag to verify the approval rating.

### 1. Intrinsically Safe wiring

#### Device nameplate (ATEX/IECEx/INMETRO/C-TICK)

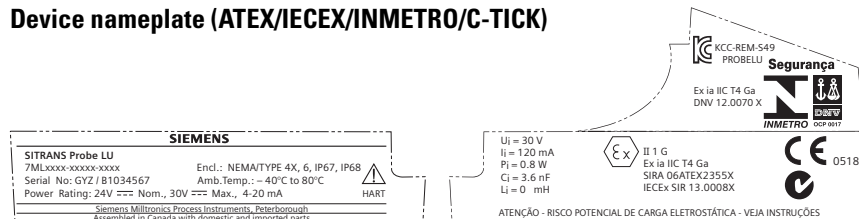

The ATEX certificate can be downloaded from the product page of our website at: [www.siemens.com/probelu](http://www.siemens.com/probelu). Go to **Support > Approvals / Certificates**.

The IECEx certificate listed on the nameplate can be viewed on the IECEx website. Go to: <http://iecex.iec.ch> and click on **Ex Equipment Certificates of Conformity** then enter the certificate number IECEx SIR 13.0008X.

#### Device nameplate (FM/CSA)

SIEMENS			
<b>SITRANS Probe LU</b> 7ML1234-78910-ABC-D Serial No: GYZ / S1034567 Power Rating: 24V $\approx$ Nom., 30V $\approx$ Max., 4-20 mA <small>Siemens Milltronics Process Instruments, Peterborough Assembled in Canada with domestic and imported parts</small>		Class I, Div 1, Group A, B, C, D Class II, Div 1, Group E, F, G Class III Temp. Code: T4 CSA per drawing: 23650517 FM per drawing: 23650516 WARNING: Possible static hazard, do not rub or clean on site.	
Encl.: NEMA/TYPE 4X, 6, IP67, IP68 Serial No: GYZ / S1034567 Power Rating: 24V $\approx$ Nom., 30V $\approx$ Max., 4-20 mA <small>Siemens Milltronics Process Instruments, Peterborough Assembled in Canada with domestic and imported parts</small>		Vmax = 30 V Imax = 120 mA Pmax = 0.8 W Ci = 3.6 nF Li = 0.5 mH HART FM APPROVED 159134	



FM Intrinsically Safe connection drawing number **23650516**, and CSA Intrinsically Safe connection drawing number **23650517** can be downloaded from the product page of our website at: [www.siemens.com/probelu](http://www.siemens.com/probelu). Go to **Support > Installation Drawings > Level Measurement > Continuous - Ultrasonic**.

- For power demands see *Loop Voltage versus Loop Resistance* on page 4.
- For wiring requirements: follow local regulations.
- Approved dust-tight and water-tight conduit seals are required for outdoor Type 4X / NEMA 4X, Type 6 / NEMA 6, IP67, IP68 locations.
- Refer to *Instructions specific to hazardous area installations (Reference European ATEX Directive 94/9/EC, Annex II, 1/0/6)* on page 7.

<sup>1</sup> If cable is routed through conduit, use only approved suitable-size hubs for waterproof application.



## 2. Non-incendive wiring (FM US only)

SIEMENS		
SITRANS Probe LU	Encl.: NEMA/TYPE 4X, 6, IP67, IP68	 Class I, Div.2, Group A, B, C, D Temp. Code: T5
7ML1234-78910-ABC-D	Amb. Temp.: -40°C to 80°C	
Serial No: GYZ / S1034567		
Power Rating: 24V --- Nom., 30V --- Max., 4-20 mA		
<small>Siemens Milltronics Process Instruments, Peterborough Assembled in Canada with domestic and imported parts</small>		
		HART

FM Class 1, Div 2 connection drawing

number **23650583** can be downloaded from the product page of our website at:

[www.siemens.com/probelu](http://www.siemens.com/probelu). Go to **Support > Installation Drawings > Level Measurement > Continuous - Ultrasonic**.

- For power demands, see *Loop Voltage versus Loop Resistance* on page 4 of Appendix A.

### Instructions specific to hazardous area installations (Reference European ATEX Directive 94/9/EC, Annex II, 1/0/6)

The following instructions apply to the SITRANS Probe LU covered by certificate number SIRA 06ATEX2355X:

1. For use and assembly, refer to the main instructions.
  2. The equipment is certified for use as Category 1G equipment.
  3. The equipment may be used with flammable gases and vapors with apparatus groups IIA, IIB, and IIC, and temperature classes T1, T2, T3, and T4.
  4. The equipment is certified for use in an ambient temperature range of -40 °C to +80 °C.
  5. The equipment has not been assessed as a safety related device (as referred to by Directive 94/9/EC Annex II, clause 1.5).
  6. Installation and inspection of this equipment shall be carried out by suitably trained personnel in accordance with the applicable code of practice (EN 60079-14 and EN 60079-17 in Europe).
  7. Repair of this equipment shall be carried out by suitably trained personnel in accordance with the applicable code of practice (e.g. EN 60079-19 within Europe).
  8. Components to be incorporated into or used as replacements in the equipment shall be fitted by suitably trained personnel in accordance with the manufacturer's documentation.
- (continued on next page)
9. It is the responsibility of the user to ensure that manual override is possible in order to shut down the equipment and protective systems incorporated within automatic processes which deviate from the intended operating conditions, provided that this does not compromise safety.
  10. The 'X' suffix to the certificate number relates to the following special conditions for safe use:

Parts of the enclosure may be non-conducting and may generate an ignition-capable level of electrostatic charge under certain extreme conditions. The user should ensure that the equipment is not installed in a location where it may be subjected to external conditions (such as high-pressure steam) which might cause a build-up of electrostatic charge on non-conducting surfaces.

11. If the equipment is likely to come into contact with aggressive substances, then it is the responsibility of the user to take suitable precautions that prevent it from being adversely affected, thus ensuring that the type of protection is not compromised.

Aggressive substances: e.g. acidic liquids or gases that may attack metals, or solvents that may affect polymeric materials.

Suitable precautions: e.g. regular checks as part of routine inspections or establishing from the material's data sheet that it is resistant to specific chemicals.

## 12. Equipment Marking:

The equipment marking contains at least the information on the product nameplate, shown on the inside front cover of this manual.

# Operation

## RUN Mode and PROGRAM Mode

SITRANS Probe LU has two modes of operation: **RUN** and **PROGRAM**.

SITRANS Probe LU automatically starts in **RUN** mode when power is applied, and detects the material level. The primary reading displays the material level (in meters) referenced from Empty (process empty level). This is the default start-up display mode.

System status is displayed on the LCD, or on a remote communications terminal.

## RUN Mode Display

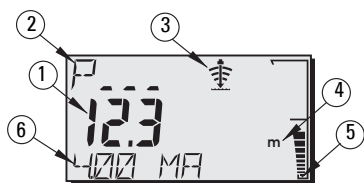

Use the hand programmer to control the display.

### Normal operation

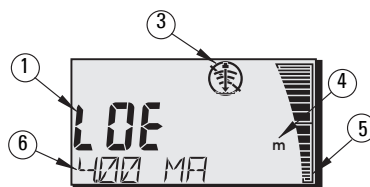

### Failsafe operation



- 1 – Primary Reading (displays level, distance, or volume<sup>1</sup>, in either units or percent).
- 2 – Secondary Reading (displays Parameter number for Auxiliary Reading<sup>2</sup>)
- 3 – Echo status indicator: Reliable Echo  or Unreliable Echo 
- 4 – Units or Percent
- 5 – Active bar graph represents material level
- 6 – Auxiliary Reading (depending on the parameter selected, it displays milliAmp value, distance, or echo confidence, with units where applicable.)

<sup>1</sup>. For details on displaying flow instead of volume, please see P050 in the full manual.

<sup>2</sup>. Press  to display the auxiliary reading field when in **RUN** mode.

If the echo confidence drops below the echo confidence threshold, the failsafe timer starts running. When the timer expires, the letters **LOE** (Loss of Echo) alternate with the reading every two seconds, and the Reliable Echo indicator is replaced by the Unreliable indicator. When a valid reading is received, the level reading display returns to normal operation.

## PROGRAM Mode Display

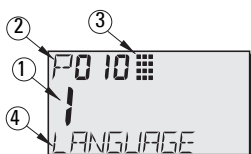

- 1– Primary Reading (displays parameter value)
- 2– Secondary Reading (displays parameter number)
- 3– Programming indicator
- 4– Auxiliary Reading (displays parameter names for P001 to P010, if a language is selected. It displays the index value for indexed parameters, such as P054).

## Programming

- Set parameters to suit your specific application.
- Activate **PROGRAM** mode at any time, to change parameter values and set operating conditions.
- For local programming, use the Siemens hand programmer.
- For programming from a distance, use either a PC running SIMATIC PDM, or a HART handheld communicator.

## Hand programmer

For direct access to SITRANS Probe LU, point the programmer at the SITRANS Probe LU display and press the keys. (For detailed instructions, see the next page.)

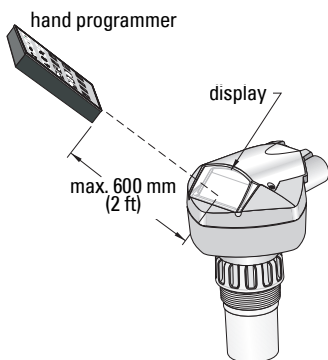

Key	Programming Mode
	Decimal point <sup>1</sup>
	Negative value
	<b>CLEAR</b> value
	<b>TOGGLE</b> between Units and % on parameter value
	End <b>PROGRAM</b> session and enable <b>RUN</b> mode
	Update echo quality parameters
	Parameter scroll-up
	Parameter scroll-down
	<b>DISPLAY</b> opens parameter fields
	<b>ENTER</b> the displayed value

1. Press plus three-digit parameter number, to set parameter to show in the auxiliary display.

## Low temperature effects on RUN/PROGRAM modes

If the internal temperature falls to  $-30\text{ }^{\circ}\text{C}$  ( $-22\text{ }^{\circ}\text{F}$ ) or below, it will affect both RUN and PROGRAM modes.

**RUN** mode will operate normally, with the following exceptions:

- hand programmer operation is disabled
- the LCD displays only limited information: the bar graph and the reliable/unreliable echo indicator

**PROGRAM** mode:

- hand programmer operation is disabled

### Security: (P000: Lock)



Value		Description
Value stored in P069	*	Lock off: programming permitted
other		Lock activated: no changes permitted

\* Factory setting for P069 is 1954: after a new value is entered and accepted, it becomes the default setting.









## Activating SITRANS Probe LU

Power up the instrument. SITRANS Probe LU starts in **RUN** mode.

### Notes:

- Keep infrared devices such as laptops, cell phones, and PDAs, away from SITRANS Probe LU to prevent inadvertent operation.
- The following instructions apply when using the Hand Programmer.
- Do not use the Hand Programmer at the same time as SIMATIC PDM, or erratic operation may result.
- Press **PROGRAM**  then **DISPLAY**  to access **PROGRAM** mode, and press **PROGRAM**  to return to **RUN** mode.
- You do not need to key in initial zeros when entering a parameter number: for example, for P005, key in **5**.

## Accessing a parameter

1. Press **PROGRAM**  then **DISPLAY** , to activate **PROGRAM** mode.
2. Either use the **ARROW** keys   to scroll to a different parameter, or:
3. Press **DISPLAY**  to open the Parameter Number field.
4. Key in the desired parameter number followed by **ENTER** .
5. **For example:** press **5**  then .
6. The LCD displays the new parameter number and value.





## Changing a Parameter Value

### Notes:

- Security must be disabled to enable programming: set P000 to the Unlocked Value stored in P069. (A remote master can still change configuration, if P799 is set to allow this.)
- Invalid entries will be rejected or limited.
- **CLEAR**  can be used to clear the field.





1. Key in the new value.
2. Press **ENTER**  to set the value.

### Parameter Reset to Factory Default

1. Scroll to the parameter or enter its address.
2. Press **CLEAR**  then **ENTER** . The value returns to the default setting.

### Master Reset (P999)

Returns all parameters except P000 and P069 to default settings. (The learned TVT curve is not lost.)

1. Press **PROGRAM** , then **DISPLAY**  to activate **PROGRAM** mode.
2. Press **DISPLAY**  to open parameter fields.
3. Key in **999**.
4. Press **CLEAR**  then **ENTER** , to Clear All and initiate reset. The LCD displays **C.ALL**
5. Reset complete. (Reset takes several seconds to complete.)



# Quick Setup: steps 1 to 10

**Note:** Default values (factory settings) are marked by an asterisk (\*) in the tables.

## 1. Select language (P010: Language)

Values	0	*	Numeric/None	ENGLISH	DEUTSCH	FRANÇAIS	ESPAÑOL
		1		English	P000 LOCK	VERRIEGELG	VERROUIL
	2		German	P001 OPERATION	BETRIEB	FONCTIONMT	FUNCIONAM.
	3		French	P003 MEAS RESP	REAKTIONSZ	TEMPS REP	TIEMPO R.
	4		Spanish	P004 ANTENNA	ANTENNE	ANTENNE	ANTENA
				P005 UNITS	EINHEIT	UNITES	UNIDADES
				P006 EMPTY	MESSBER.	VIDE	VACIO
				P007 SPAN	MESSSPANNE	PLAGE	RANGO
				P010 LANGUAGE	SPRACHE	LANGUE	IDIOMA

## 2. Set P001: Operation (measurement mode)

### Notes:

- Setting P001 resets Span (P007), unless Span has previously been set to a different value.
- Changing P001 may reset Output Function (P201): this applies to HART only.

Values	1	*	Level returns distance to material level referenced from Empty (process empty level). The reading is returned in volumetric units if parameters 050 to 055 are set to enable this.
	2		Space returns distance to material level referenced from Span (process full level).
	3		Distance returns distance to material level from reference point (transducer face).

### mA Output with Level, Space, and Distance operation

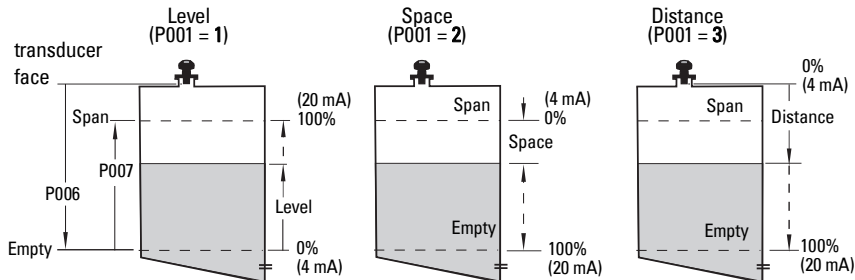

## 3. Set Measurement Response (P003)

Values	1	*	slow	0.1m/minute
	2		medium	1m/minute
	3		fast	10m/minute

Set P003 to a measurement response speed just faster than the maximum filling or emptying rate (whichever is greater).

#### 4. Select measurement units (P005)

Values	1	* meters
	2	centimeters
	3	millimeters
	4	feet
	5	inches

#### 5. Set process empty level (P006: Empty)

##### Note:

- P006 and P007 are interlinked: see notes attached to P007.

Values	Range	0.0000 to 6.000 m (20 ft) or 0.0000 to 12.000 m (40 ft)
	Default	Maximum range

Empty can be set to any distance: not necessarily the bottom of the tank.

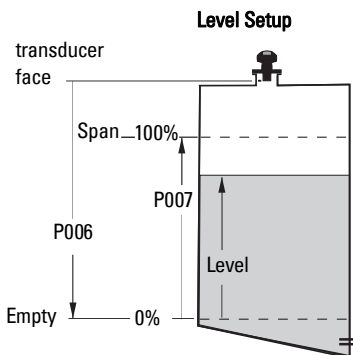

#### 6. Set measurement range (P007: Span)

Values	Range	0.0000 to 6.000 m (20 ft) or 0.0000 to 12.000 m (40 ft)
	Default	5.725 m (18.78 ft) or 11.725 m (38.47 ft)

Span can be set at any distance above Empty level

##### Notes:

- Setting P006 resets Span, if it has not previously been set to a different value.
- The default setting for Span is based on Operation (P001) and Empty (P006). Span is set to Empty minus 110% of Blanking distance<sup>1</sup>, unless Operation is set to **distance** (P001=3). In this case, Span is set to Empty distance.
- Always prevent the monitored surface from approaching within 0.3 m (1 ft) of the transducer face. This provides a 0.05 m (2") safety margin, as 0.25 m (10") is the minimum distance detectable.

#### 7. Minimize false reflections: Set P838 (Auto False Echo Suppression Distance)

Use P838 and P837 together: follow the instructions for P837.

Value	Range (depends on model)	Maximum range: 0.000 to 6.000 m (20 ft) or 0.000 to 12 m (40 ft)
	Default	1.000 m (3.28 ft)

<sup>1</sup> Default setting for Blanking is 0.25 m (10").

## 8. Enable False Echo Suppression: set P837 (Auto False Echo Suppression)

Value	0		Off
	1	*	Use "learned" TVT
	2		"Learn"

### Using P837 and P838 (perform this function at low tank levels)

The TVT (Time Varying Threshold) curve sets a threshold which screens out false echoes<sup>1</sup>. If SITRANS Probe LU displays an incorrect full level, or if the reading fluctuates between a false high level and a correct level, use P838 and P837 together to elevate the TVT (Time Varying Threshold) in this region and de-sensitize the receiver from any 'base noise' caused by internal transducer reflections, nozzle echoes, or other vessel false echoes<sup>2</sup>.

### Using P837 and P838 (continued)

#### Notes:

- Use this function only if there is a minimum distance of 2 meters from SITRANS Probe LU to the material. This function works best if the vessel is empty or nearly empty.
  - Set P837 and P838 during start up, if possible.
  - If the vessel contains an agitator, the agitator should be running.
- a. Determine the actual distance from the transducer face to the material level.
  - b. Select P838 and key in [distance to material level – 0.5 m].
  - c. Select P837, then press **2** (Learn) and **ENTER** . P837 will automatically revert to **1** (use Learned TVT) after a few seconds.

## 9. Return to RUN

Press **PROGRAM**  to return to **RUN** mode: setup is complete.

## SITRANS Probe LU Communications: HART

**Note:** See *mA Output with Level, Space, and Distance operation* on page 12 for an illustration of the mA output with different modes of operation.

- You will need the full manual to acquire the list of applicable parameters.
- Please contact your local representative concerning the availability of the HART DD for SITRANS Probe LU.
- We recommend that you use SIMATIC Process Device Manager (PDM) to program your instrument.

## Maintenance

SITRANS Probe LU requires no maintenance or cleaning.

### Unit Repair and Excluded Liability

For detailed information, please see the inside back cover.

<sup>1</sup>. False echoes can be caused by obstructions in the beam path.

<sup>2</sup>. For more details on Auto False Echo Suppression, please see the full manual.