

# Radar Transmitters

SITRANS LR400 (HART/PROFIBUS PA)

Quick Start Manual · 03/2013



SITRANS

**SIEMENS**



# SITRANS LR 400 Quick Start Manual

This manual outlines the essential features and functions of the SITRANS LR 400 Solids and Liquids versions. We strongly advise you to acquire the detailed version of the manuals so you can use your device to its fullest potential. The complete manuals are available on our web site: <https://pia.khe.siemens.com/index.asp?Nr=4936>.

The printed manual is available from your local Siemens Milltronics representative.

Questions about the contents of this manual can be directed to:

Siemens Milltronics Process Instruments  
1954 Technology Drive, P.O. Box 4225  
Peterborough, Ontario, Canada, K9J 7B1  
E-mail: [techpubs.smpi@siemens.com](mailto:techpubs.smpi@siemens.com)

## Copyright Siemens Milltronics Process Instruments 2013. All Rights Reserved

## Disclaimer of Liability

We encourage users to purchase authorized bound manuals, or to view electronic versions as designed and authored by Siemens Milltronics Process Instruments. Siemens Milltronics Process Instruments will not be responsible for the contents of partial or whole reproductions of either bound or electronic versions.

While we have verified the contents of this manual for agreement with the instrumentation described, variations remain possible. Thus we cannot guarantee full agreement. The contents of this manual are regularly reviewed and corrections are included in subsequent editions. We welcome all suggestions for improvement.

Technical data subject to change.

## Safety Guidelines

Warning notices must be observed to ensure personal safety as well as that of others, and to protect the product and the connected equipment. These warning notices are accompanied by a clarification of the level of caution to be observed.

**!** **WARNING: This product can only function properly and safely if it is correctly transported, stored, installed, set up, operated, and maintained.**

**Note:** Process temperature and pressure capabilities are dependent upon information on the process device tag (liquids version only). The reference drawing listed can be downloaded from the Siemens Milltronics web site at [www.siemens.com/processautomation](http://www.siemens.com/processautomation).

**!** **WARNING:** This product is designated as a Pressure Accessory per Directive 97/23/EC and is not intended for use as a safety device.

## SITRANS LR 400

The SITRANS LR 400 is to be used only in the manner outlined in this manual, otherwise protection provided by the equipment may be impaired.

The SITRANS LR 400 is a long-range FMCW radar level instrument. A liquids version (7ML5421) is available for use in liquids storage, performing well on low dielectric liquids or sticky materials requiring a purging unit. A solids version (7ML5420) incorporates the Easy Aimer design for use in solids, especially conditions of extreme dust.

The SITRANS LR 400 supports HART,<sup>1</sup> or PROFIBUS PA (optional).

## Specifications

### Ambient/Operating Temperature

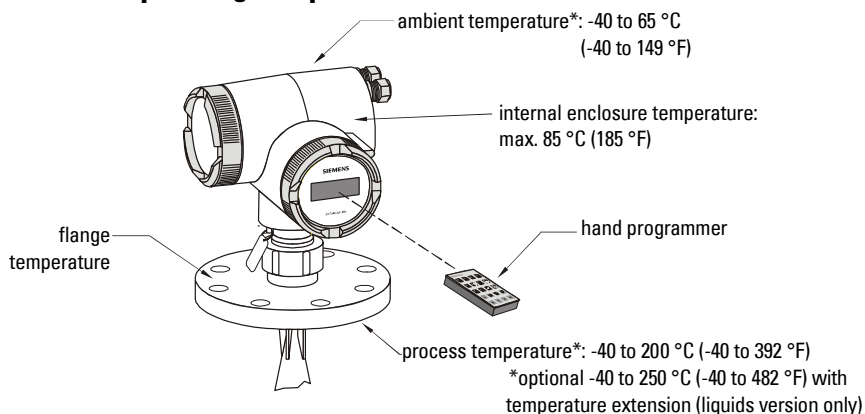

**! WARNING: Internal temperature must not exceed 85 °C (185 °F)!**

### Power

- 120 to 230 V AC, ±15%, 50/60 Hz, 6 W (12 VA)  
or
- 24 V DC, +25/-20%, 6 W (optional)

<sup>1</sup> HART® is a registered trademark of the HART Communications Foundation.

\* -20 °C (-4 °F) temperature rating available on SITRANS LR 400 with ATEX rating.

## Installation Conditions

- location: indoor/outdoor
- altitude: 2000 m (6,562 ft) max.
- installation category: II
- pollution degree: 4
- range: up to 50 m (164 ft)

### **! WARNINGS:**

- The user is responsible for the selection of bolting and gasket materials which will fall within the limits of the flange and its intended use and which are suitable for the service conditions.
- Never attempt to loosen, remove, or disassemble process connection or instrument housing while vessel contents under pressure.

## Approvals (verify against device nameplate)

The following are possible approvals:

- General CSAus/c, CE, FM
- Radio FCC, Industry Canada, European Radio
- Explosion Protection CSA, FM, ATEX  
INMETRO: DNV 12.0086  
Ex d IIC T6 Gb  
Ex d e mb IIC T6 Gb  
Ex d e [ib Gb] mb IIC T6 Gb  
Ex d e [ia Ga] mb IIC T6 Gb  
IP67  
-20 °C ≤ Ta ≤ +65 °C  
DNV #OCP 0017  
ABNT NBR IEC 60079-0:2008  
ABNT NBR IEC 60079-1:2009,  
ABNT NBR IEC 60079-7:2008,  
ABNT NBR IEC 60079-11:2009,  
ABNT NBR IEC 60079-18:2010

**Note:** Approval certification manual 7ML19985FP82 will be included with ATEX approved Liquids versions (7ML5421) with Gas approvals. ATEX approval information for SITRANS LR 400 with Dust approvals is included on page 8.

### **! WARNINGS:**

- This product is designated as a Pressure Accessory per Directive 97/23/EC and is not intended for use as a safety device.
- Materials of construction are chosen based on their chemical compatibility (or inertness) for general purposes. For exposure to specific environments, check with chemical compatibility charts before installing.

## Mounting

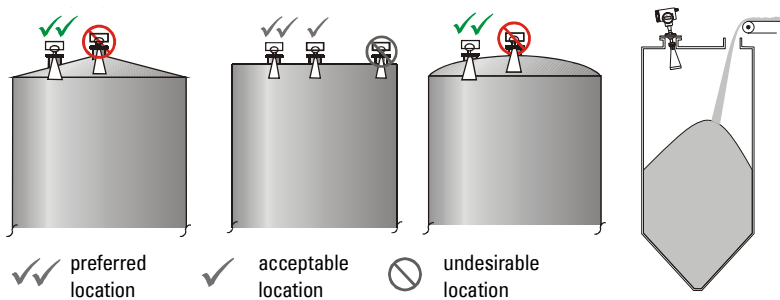

## Liquids Version

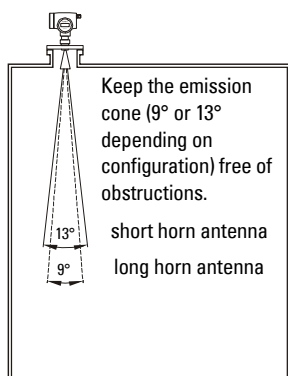

### Installation in Mounting Nozzle

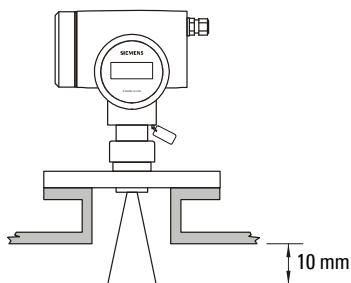

## Solids Version

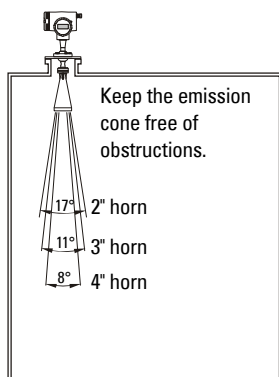

### Installation in Mounting Nozzle

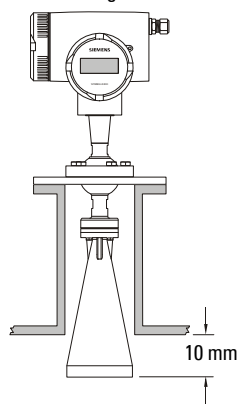

**! WARNING:** Improper installation may result in loss of process pressure.

# SITRANS LR 400 Wiring Requirements

- All field wiring must have insulation suitable for the applied input voltage.
- 4-20 mA, PROFIBUS PA, DC input circuits, 14-20 AWG, shielded copper wire
- AC input circuit, minimum 14 AWG copper wire
- Recommended torque on terminal clamping screws, 0.5-0.6 Nm
- The 24 V DC version must only be connected to SELV or PELV circuits.

## SITRANS LR 400 Wiring

AC

HART Wiring

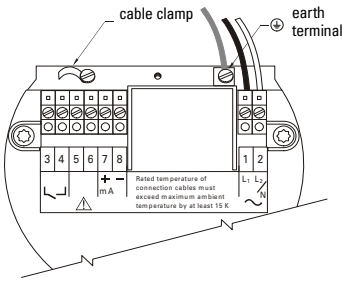

PROFIBUS Wiring

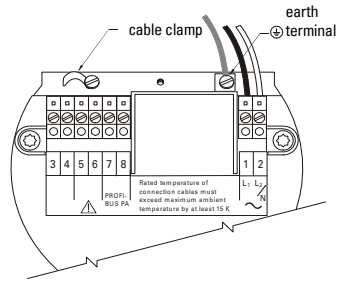

DC

HART Wiring

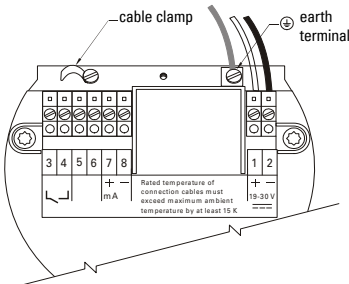

PROFIBUS Wiring

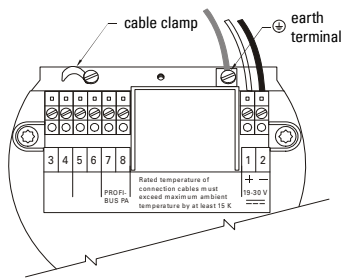

## Functional Dimensions

Parameters:



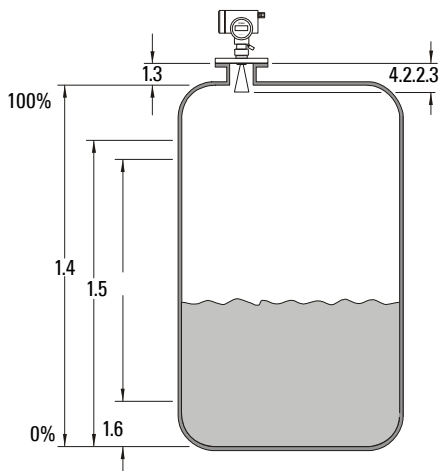

- 1.3 Nozzle height
- 4.2.2.3 Dead band
- 1.6 Lower range value (LRV)
- 1.5 Upper range value (URV)
- 1.4 Vessel height



## Local Programming

To begin parameter changes, use the hand programmer and press LEFT  once. **Main Menu** is displayed in the first line of the LCD. Then program the unit beginning with the Auto-Setup parameters.

## Functions of Hand Programmer Keys

- 
  - Changes display from RUN mode to PROGRAM mode
  - Operates as a CANCEL key when programming input position is at the far left
  - Moves input position to the left during PROGRAM mode
- 
  - Operates as an ENTER key when input position is at the far right
  - Moves input position to the right during PROGRAM mode
-  
  - Changes input variable up or down

## Auto-Setup

After switching on the SITRANS LR 400, and after a successful self test, press LEFT  to access the parameters. Set the Auto-Setup parameters to make the system operational:

- language of the local user interface
- unit of length of the measured level (cm,m,mm,ft,in)
- nozzle height in the selected unit of length
- vessel height in the selected unit of length
- LRV as a distance from the bottom of the vessel
- URV as a distance from the bottom of the vessel
- damping of the measured level in seconds
- application type
- bus-address by PROFIBUS PA communication (on PROFIBUS models)



# SITRANS LR 400 Communications

## HART/mA Connections

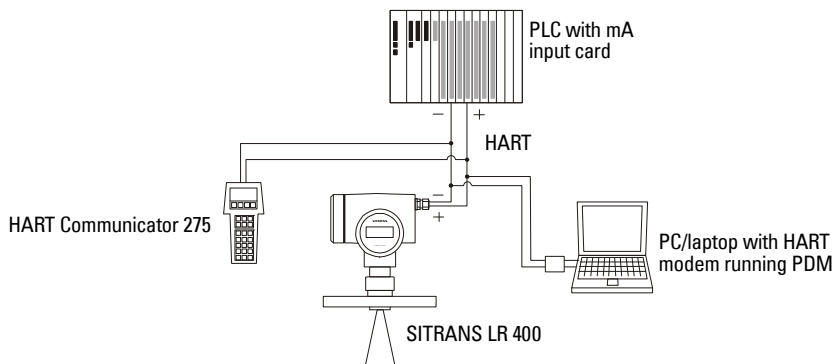

## PROFIBUS PA Connections

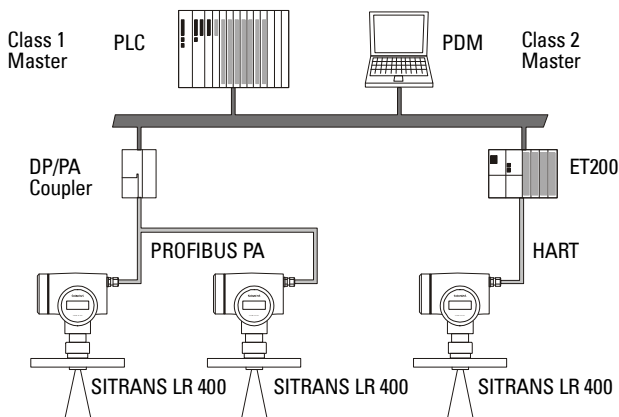

## HART or PROFIBUS PA

- You will need the full manual to acquire the list of applicable parameters.
- The HART Device Descriptor (DD) may be obtained from the HART Communications Foundation at [www.hartcomm.org](http://www.hartcomm.org)
- Many software packages can be used to program the instrument, but we recommend that you use Simatic Process Device Manager (PDM) to program your instrument on a network. This software package is designed to permit easy configuration, monitoring and troubleshooting of HART and PROFIBUS PA devices.
- The GSD file for PROFIBUS PA can be downloaded it from our web site at [www.siemens.com/processautomation](http://www.siemens.com/processautomation)

## Maintenance

The SITRANS LR 400 requires no maintenance or cleaning under normal operation conditions. Under severe operating conditions, the antenna may require periodic cleaning using a brush or high pressure air cleaning.

## Unit Repair and Excluded Liability

For detailed information, please see the inside back cover.

# Instructions specific to hazardous area installations

## (Reference European ATEX Directive 94/9/EC, Annex II, 1/0/6)

The following instructions apply to equipment covered by certificate number DMT 01 ATEX E 038:

1. For use and assembly, refer to the main instructions.
2. The equipment is certified for use as Category 1/2 D equipment. The Essential Health and Safety Requirements are assured by compliance with EN 50281-1-1:1998; Dust Explosion Protection.
3. The equipment may be used with dust and fibers with apparatus temperature class T. See table below.
4. Thermal Data:
  - a. For **7ML5421 Series** (Liquids version)
    - Permitted ambient temperature at the horn antenna (Category 1D):  
 $-20\text{ °C} \leq T_{\text{amb}} \leq +250\text{ °C}$
    - Permitted ambient temperature at the electronic enclosure (Category 2D):  
 $-20\text{ °C} \leq T_{\text{amb}} \leq +65\text{ °C}$
    - Maximum permitted temperature within electronic enclosure (Category 1D):  
 $85\text{ °C}$

Ambient temperature at the horn antenna (Category 1D)	Maximum surface temperature at the horn antenna (Category 1D)	Maximum surface temperature Category 2D (electronic enclosure resp. flange)
$-20\text{ °C} \leq T_{\text{amb}} \leq +60\text{ °C}$	72 °C	70 °C at $T_{\text{amb}} \leq 65\text{ °C}$ in Category 2
$-20\text{ °C} \leq T_{\text{amb}} \leq +100\text{ °C}$	112 °C	100 °C independent from $T_{\text{amb}}$ in Category 2
$-20\text{ °C} \leq T_{\text{amb}} \leq +250\text{ °C}$	262 °C	250 °C independent from $T_{\text{amb}}$ in Category 2

- b. For **7ML5420 Series** (Solids version)
- Permitted ambient temperature at the horn antenna (Category 1D):  
 $-20\text{ °C} \leq T_{\text{amb}} \leq +200\text{ °C}$
  - Permitted ambient temperature at the electronic enclosure (Category 2D):  
 $-20\text{ °C} \leq T_{\text{amb}} \leq +65\text{ °C}$
  - Maximum permitted temperature within electronic enclosure (Category 1D):  
 $85\text{ °C}$

Ambient temperature at the horn antenna (Category 1D)	Maximum surface temperature at the horn antenna (Category 1D)	Maximum surface temperature Category 2D (electronic enclosure resp. flange)
$-20\text{ °C} \leq T_{\text{amb}} \leq +60\text{ °C}$	72 °C	70 °C at $T_{\text{amb}} \leq 65\text{ °C}$ in Category 2
$-20\text{ °C} \leq T_{\text{amb}} \leq +100\text{ °C}$	112 °C	100 °C independent from $T_{\text{amb}}$ in Category 2
$-20\text{ °C} \leq T_{\text{amb}} \leq +200\text{ °C}$	212 °C	200 °C independent from $T_{\text{amb}}$ in Category 2

5. The equipment has not been assessed as a safety related device (as referred to by Directive 94/9/EC Annex II, clause 1.5).
6. Installation and inspection of this equipment shall be carried out by suitably trained personnel in accordance with the applicable code of practice (EN 60079-14 and EN 60079-17 in Europe).
7. Repair of this equipment shall be carried out by suitably trained personnel in accordance with the applicable code of practice (e.g. EN 60079-19 within Europe).
8. Components to be incorporated into or used as replacements in the equipment shall be fitted by suitably trained personnel in accordance with the manufacturer's documentation.
9. It is the responsibility of the user to ensure that manual override is possible in order to shut down the equipment and protective systems incorporated within automatic processes, which deviate from the intended operating conditions, provided that this does not compromise safety.
10. Equipment Marking:  
 The equipment marking contains at least the information on the product label, shown on the inside front cover of this manual.

**Note: ATEX approval information for SITRANS LR 400 Gas approvals is found in the ATEX certificate manual 7ML19985FP82.**

