

Radar Transmitters

SITRANS LR200 (HART)

Operating Instructions · 12/2013



SITRANS

SIEMENS

Safety Guidelines: Warning notices must be observed to ensure personal safety as well as that of others, and to protect the product and the connected equipment. These warning notices are accompanied by a clarification of the level of caution to be observed.

Qualified Personnel: This device/system may only be set up and operated in conjunction with this manual. Qualified personnel are only authorized to install and operate this equipment in accordance with established safety practices and standards.

Unit Repair and Excluded Liability:

- The user is responsible for all changes and repairs made to the device by the user or the user's agent.
- All new components are to be provided by Siemens Milltronics Process Instruments.
- Restrict repair to faulty components only.
- Do not reuse faulty components.

Warning: Cardboard shipping package provides limited humidity and moisture protection. This product can only function properly and safely if it is correctly transported, stored, installed, set up, operated, and maintained.

This product is intended for use in industrial areas. Operation of this equipment in a residential area may cause interference to several frequency based communications.

Note: Always use product in accordance with specifications.

Copyright Siemens AG 2013. All Rights Reserved

Disclaimer of Liability

This document is available in bound version and in electronic version. We encourage users to purchase authorized bound manuals, or to view electronic versions as designed and authored by Siemens Milltronics Process Instruments. Siemens Milltronics Process Instruments will not be responsible for the contents of partial or whole reproductions of either bound or electronic versions.

While we have verified the contents of this manual for agreement with the instrumentation described, variations remain possible. Thus we cannot guarantee full agreement. The contents of this manual are regularly reviewed and corrections are included in subsequent editions. We welcome all suggestions for improvement.

Technical data subject to change.

MILLTRONICS® is a registered trademark of Siemens Milltronics Process Instruments.

Contact SMPI Technical Publications

at the following address:

Technical Publications
Siemens AG
Siemens Milltronics Process Instruments
1954 Technology Drive, P.O. Box 4225
Peterborough, Ontario, Canada, K9J 7B1
Email: techpubs.smpi@siemens.com

European Authorized Representative

Siemens AG
Industry Sector
76181 Karlsruhe
Deutschland

- For a selection of Siemens Milltronics level measurement manuals, go to: **www.siemens.com/processautomation**. Under Process Instrumentation, select *Level Measurement* and then go to the manual archive listed under the product family.
- For a selection of Siemens Milltronics weighing manuals, go to: **www.siemens.com/processautomation**. Under Weighing Technology, select *Continuous Weighing Systems* and then go to the manual archive listed under the product family.

Table of Contents

Table of Contents	i
Safety Notes	1
Safety marking symbols	1
FCC Conformity	1
CE Electromagnetic Compatibility (EMC) Conformity	2
The Manual	2
Technical Support	3
SITRANS LR200 Overview	5
Specifications	6
Power	6
Performance	6
Interface	7
Mechanical	7
Environmental	8
Process	9
Approvals	9
Programmer (infrared keypad)	11
Dimensions: Uni-Construction Polypropylene Rod Antenna	12
Installation	14
Pressure Equipment Directive, PED, 97/23/EC	15
Mounting location	15
Nozzle design	15
Nozzle location	15
Orientation in a vessel with obstructions	17
Mounting on a Stillpipe or Bypass Pipe	17
Installation Instructions	18
Wiring	19
Power	19
Connecting SITRANS LR200	19
Wiring setups for hazardous area installations	21
Intrinsically Safe wiring	21
Non-Sparking wiring	23
Non-incendive wiring (FM US only)	23
Flameproof wiring	23
Increased safety wiring	24
Explosion-proof wiring (FM/CSA US/Canada only)	24
Instructions specific to hazardous area installations	25
Operating via the handheld programmer	26
Activating SITRANS LR200	26
The LCD Display	26
Handheld Programmer	27
Programming SITRANS LR200	28
Quick Start Wizard via the handheld programmer	31
Auto False Echo Suppression	33
Requesting an Echo Profile	33

Level application example	34
Operating via SIMATIC PDM	35
Functions in SIMATIC PDM	35
Features of SIMATIC PDM Rev. 6.0, SP4	35
Features of SIMATIC PDM Rev. 5.2, SP1	36
Initial Setup	36
Deactivating Buffers	36
Updating the Electronic Device Description (EDD)	37
Configuring a new device	37
Quick Start Wizard via SIMATIC PDM	37
Linearization	41
Configuring a stillpipe application	43
Changing parameter settings using SIMATIC PDM	44
Parameters accessed via pull-down menus	44
Echo Profile Utilities	45
Echo profile	46
TVT Shaper	47
Auto False Echo Suppression	48
Echo Setup	50
Maintenance	50
Select Analog Output	51
Self Test	51
Loop-Test	52
Configuration Flag Reset	52
Master Reset	52
Wear	52
HART Communication	52
Diagnostics	52
Process Variables	53
Trend	53
Device Status	54
Update	54
Security	55
Operating via AMS Device Manager	56
Functions in AMS Device Manager	56
Features of AMS Device Manager	56
Device Description (DD)	57
Configuring a new device	57
Startup	57
Master Reset	58
Pull-down menu access	58
Device configuration	58
Quick Start Wizard via AMS Device Manager	59
Quick Start	59
Linearization	60
Using Linearization via the Quick Start wizard	60
Changing parameter settings using AMS Device Manager	61
Operation	61
Setup	62
Signal Processing	63

Signal Processing (continued)	64
Local Display	65
Maintenance and Diagnostics	65
Communication	66
Security	66
Device Diagnostics	67
Process Variables	67
Password Protection	68
User Manager utility	68
AMS Menu Structure	69
Operating via FDT (Field Device Tool)	73
Device Type Manager (DTM)	73
SITRANS DTM	73
The instrument EDD	73
Configuring a new device via FDT	73
Parameter Reference	75
Quick Start	75
Language	75
Material	75
Response Rate	75
Units	75
Operating Mode	76
Low Calibration Point	76
High Calibration Point	76
Apply? (Apply changes)	76
Setup	76
Device	76
Sensor	76
Calibration	77
Rate	78
Fail-safe	80
Analog Output Scaling	81
Linearization	83
Signal Processing	87
Diagnostics	95
Echo Profile	95
Electronics Temperature	96
Service	96
Master Reset	96
Remaining Device Lifetime	97
Remaining Sensor Lifetime	100
Service Schedule	103
Calibration Schedule	106
Manufacture Date	109
Powered Hours	109
Power-on Resets	109
LCD Fast Mode	110
LCD Contrast	110
Memory Test	110
Communication	111

Device Address	111
Security.....	111
Remote Access	111
Local Access	112
Language.....	112
Appendix A: Alphabetical Parameter List	113
Appendix B: Troubleshooting	115
Communication Troubleshooting	115
Device Status Icons	116
General Fault Codes	117
Operation Troubleshooting	121
Appendix C: Maintenance	123
Unit Repair and Excluded Liability	123
Replacing the antenna	123
Appendix D: Technical Reference	124
Principles of Operation	124
Echo Processing	124
Process Intelligence	124
Echo Selection	125
Measurement Range	129
Measurement Response	129
Analog Output	130
Sensor Mode	131
Current Output Function	131
Loss of Echo (LOE)	132
Maximum Process Temperature Chart	133
Process Pressure/Temperature derating curves	134
Pressure Equipment Directive, PED, 97/23/EC	134
PTFE Rod Antenna ASME Hole Pattern, 150 lb	135
PTFE Rod Antenna, DN Hole Pattern, PN16	135
PTFE Rod Antenna Threaded Connection	136
PTFE Rod Antenna Sanitary Connection	136
Horn Antenna or Waveguide, ASME Hole Pattern, 150 lb	137
Horn Antenna or Wave Guide DN Hole Pattern, PN16	137
PTFE Rod Antenna, DN Hole Pattern, PN16, PN40	138
Horn Antenna or Waveguide, DN Hole Pattern, PN16, PN40	138
Startup Behavior	139
Loop power	139
Typical Connection Drawing	139
Allowable operating area of SITRANS LR200	139
.....	140
Appendix E: Application Examples	141
Liquid resin in storage vessel, level measurement	141
Horizontal vessel with volume measurement.....	142
Sliding Waveguide on Anaerobic Digesters	144
Application with Stillpipe.....	146
Appendix F: HART Communications	148
SIMATIC PDM	148

HART Electronic Device Description (EDD)	148
HART Communicator 375 Menu Structure	149
HART Version	151
Burst Mode	151
HART Multidrop Mode	151
Appendix G: Flange Adapter Versions	152
Dimensions:	152
Threaded connection, PTFE Rod	152
PTFE Rod Antenna, Flat-Face Flange	153
Threaded Connection, PTFE Rod, external shield	154
Flat-Face Flange with Horn Antenna and Waveguide extension	155
Flanged Horn dimensions	156
Raised Face or Flat-Face Flange with Waveguide	157
Sliding Waveguide Configuration	158
Sanitary connection, Rod Antenna, PTFE or HDPE	159
Raised-Face Flange per EN 1092-1	160
Raised-Face Flange Dimensions	161
Flat-Face Flange (constant thickness series)	162
Flat-Face Flange Dimensions	163
Flange Mounting Instructions	165
Rod Assembly	166
Rod Extension Requirements	166
Mounting Guidelines	167
Appendix H: Firmware Revision History	169
Glossary	171
Index	175
LCD menu structure	179

Notes

Safety Notes

Special attention must be paid to warnings and notes highlighted from the rest of the text by grey boxes.



WARNING: relates to a caution symbol on the product, and means that failure to observe the necessary precautions can result in death, serious injury, and/or considerable material damage.



WARNING¹⁾: means that failure to observe the necessary precautions can result in death, serious injury, and/or considerable material damage.

Note: means important information about the product or that part of the operating manual.

Safety marking symbols

In manual	On product	Description
		Earth (ground) Terminal
		Protective Conductor Terminal
		(Label on product: yellow background.) WARNING: refer to accompanying documents (manual) for details.

FCC Conformity

US Installations only: Federal Communications Commission (FCC) rules



WARNING: Changes or modifications not expressly approved by Siemens Milltronics could void the user's authority to operate the equipment.

Notes:

- This equipment has been tested and found to comply with the limits for a Class A digital device, pursuant to Part 15 of the FCC Rules. These limits are designed to provide reasonable protection against harmful interference when the equipment is operated in a commercial environment.
- This equipment generates, uses, and can radiate radio frequency energy and, if not installed and used in accordance with the instruction manual, may cause harmful interference to radio communications. Operation of this equipment in a residential area is likely to cause harmful interference to radio communications, in which case the user will be required to correct the interference at his own expense.

¹⁾ This symbol is used when there is no corresponding caution symbol on the product.

CE Electromagnetic Compatibility (EMC) Conformity

This equipment has been tested and found to comply with the following EMC Standards:

EMC Standard	Title
CISPR 11:2004/EN 55011:1998+A1:1999&A2:2002, CLASS B	Limits and methods of measurements of radio disturbance characteristics of industrial, scientific, and medical (ISM) radio-frequency equipment.
EN 61326:1997+A1:1998+A2:2001+A3:2003 (IEC 61326:2002)	Electrical Equipment for Measurement, Control and Laboratory Use – Electromagnetic Compatibility.
EN61000-4-2:2001	Electromagnetic Compatibility (EMC) Part 4-2: Testing and measurement techniques – Electrostatic discharge immunity test.
EN61000-4-3:2002	Electromagnetic Compatibility (EMC) Part 4-3: Testing and measurement techniques – Radiated, radio-frequency, electromagnetic field immunity test.
EN61000-4-4:2004	Electromagnetic Compatibility (EMC) Part 4-4: Testing and measurement techniques – Electrical fast transient/burst immunity test.
EN61000-4-5:2001	Electromagnetic Compatibility (EMC) Part 4-5: Testing and measurement techniques – Surge immunity test.
EN61000-4-6:2004	Electromagnetic Compatibility (EMC) Part 4-6: Testing and measurement techniques – Immunity to conducted disturbances, induced by radio-frequency fields.
EN61000-4-8:2001	Electromagnetic Compatibility (EMC) Part 4-8: Testing and measurement techniques – Power frequency magnetic field immunity test.

The Manual

Notes:

- This product is intended for use in industrial areas. Operation of this equipment in a residential area may cause interference to several frequency based communications.
- Please follow the installation and operating procedures for a quick, trouble-free installation and to ensure the maximum accuracy and reliability of your SITRANS LR200.
- This manual applies to the SITRANS LR200 (HART) only.

This manual will help you set up your SITRANS LR200 for optimum performance. We always welcome suggestions and comments about manual content, design, and accessibility. Please direct your comments to techpubs.smpi@siemens.com.

For other Siemens Milltronics level measurement manuals, go to: www.siemens.com/level and look under **Level Measurement**.

Application Examples

The application examples used in this manual illustrate typical installations using SITRANS LR200 (see *Appendix E: Application Examples* on page 141). Because there is often a range of ways to approach an application, other configurations may also apply.

In all examples, substitute your own application details. If the examples do not apply to your application, check the applicable parameter reference for the available options.

Technical Support

Support is available 24 hours a day.

To find your local Siemens Automation Office address, phone number and fax number go to:

www.siemens.com/automation/partner

- Click on the tab **Contact**, select **Service**, then click **Service** again to find your product group (**+Automation Technology > +Sensor Systems > +Process Instrumentation > +Level Measurement > +Continuous**). Select **Radar**.
- Select the country followed by the City/Region.
- Select **Technical Support**.

For on-line technical support go to:

www.siemens.com/automation/support-request

- Enter the device name (SITRANS LR200) or order number, then click on **Search**, and select the appropriate product type. Click on **Next**.
- You will be prompted to enter a keyword describing your issue. Then either browse the relevant documentation, or click on **Next** to email a detailed description of your issue to Siemens Technical Support staff.

Siemens IA/DT Technical Support Center: phone +49 (0)911 895 7222

Abbreviations and Identifications

Short form	Long Form	Description	Units
CE / FM / CSA	Conformité Européenne / Factory Mutual / Canadian Standards Association	safety approval	
C_i	Internal capacitance		F
D/A	Digital to analog		
DCS	Distributed Control System	control room apparatus	
dK	dielectric constant		
EDD	Electronic Device Description		
HART	Highway Addressable Remote Transducer		
I_i	Input current		mA
I_o	Output current		mA
IS	Intrinsically Safe	safety approval	
L_i	Internal inductance		mH
mH	milliHenry	10^{-3}	H
μ F	microFarad	10^{-6}	F
μ s	microsecond	10^{-6}	s
PED	Pressure Equipment Directive	safety approval	
pF	pico Farads	10^{-12}	F
ppm	parts per million		
PV	Primary Variable	measured value	
SV	Secondary Variable	equivalent value	
TB	Transducer Block		
TVT	Time Varying Threshold	sensitivity threshold	
U_i	Input voltage		V
U_o	Output voltage		V

SITRANS LR200 Overview

SITRANS LR200 is a 2-wire 6 GHz pulse radar level transmitter for continuous monitoring of liquids and slurries in storage vessels including high pressure and high temperature, to a range of 20 meters (66 feet). The instrument consists of an electronic component coupled to an antenna and either a threaded or flange type process connection.

SITRANS LR200 supports HART¹⁾ communication protocol, and the following device management software options:

- SIMATIC PDM
- AMS Device Manager

Signals are processed using Process Intelligence which has been field-proven in over 1,000,000 applications worldwide (ultrasonic and radar).

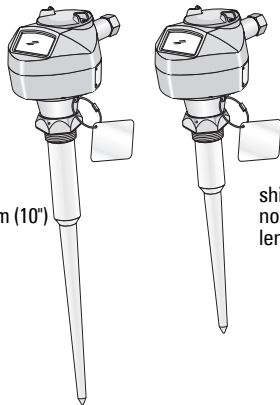

shield length 250 mm (10"):
use for long nozzles of 250 mm (10")
or less in length

shield length: 100 mm (4"):
use for nozzles of 100 mm (4")
or less in length

Programming

SITRANS LR200 is very easy to install and configure via a graphical local user interface (LUI). You can modify the built in parameters either locally via the Siemens infrared handheld programmer, or from a remote location using one of the following options:

- SIMATIC PDM
- AMS Device Manager.

Applications

- liquids and slurries
- liquid bulk storage vessels
- simple process vessels with gentle agitation

Approvals and Certificates

SITRANS LR200 is available with General Purpose approval, or for hazardous areas. The approval rating is shown on the device nameplate. See also *Approvals* on page 9.

Process Connections

A wide range of process connections and antenna options is available to suit virtually any vessel configuration.

¹⁾ HART[®] is a registered trademark of the HART Communication Foundation

Specifications

Note: Siemens Milltronics makes every attempt to ensure the accuracy of these specifications but reserves the right to change them at any time.

Power



General Purpose:

Intrinsically Safe:

Non-Sparking:

Non-incendive (FM/US only):

Nominal 24 V DC at
max. 550 Ohm



Flameproof:

Increased Safety:

Explosion-proof (FM/CSA US/Canada only):

Nominal 24 V DC at
max. 250 Ohm

- Maximum 30 V DC
- 4 to 20 mA
- Max. startup current see on page 140

Performance

Reference operating conditions according to IEC 60770-1

- ambient temperature +15 to +25 °C (+59 to +77 °F)
- humidity 45% to 75% relative humidity
- ambient pressure 860 to 1060 mbar g (86000 to 106000 N/m² g)

Measurement Accuracy (measured in accordance with IEC 60770-1)

- From end of antenna to 600 mm (1.96 ft) 40 mm (1.57")
- Remainder of Range 10 mm (0.4") or 0.1% of span (whichever is greater)

Frequency 5.8 GHz (6.3 GHz in N. America): refer to device nameplate for confirmation

Max. measurement range¹⁾ 20 m (65.6 ft)

Min. detectable distance¹⁾

- 3", 4", and 6" horn²⁾ 300 mm (11.8")
- 8" horn 330 mm (12.9")
- PP rod, 100 mm internal shield 417 mm (16.4")
- PP rod, 250 mm internal shield 567 mm (22.3")
- PTFE rod, unshielded 417 mm (16.4")
- PTFE rod, 100 mm external shield 474 mm (18.6")
- PTFE rod, 250 mm external shield 624 mm (24.5")

¹⁾ From sensor reference point. For the sensor reference point for each configuration, see *Dimensions: Uni-Construction Polypropylene Rod Antenna* on page 12 for the standard version, or *Appendix G: Flange Adapter Versions* on page 152 for other configurations.

²⁾ 3" and 4" horns should be used only in stillpipe applications.

Update time ¹⁾	minimum 1 second, depending on settings for Response Rate (2.4.1.) and LCD Fast Mode (4.9.)
Influence of ambient temperature	< 0.003%/K (average over full temperature range, referenced to maximum range)
Dielectric constant of material measured	
• dK > 3 (for < 3 use waveguide antenna or stillpipe)	
Memory:	
• non-volatile EEPROM	
• no battery required.	

Interface

Analog output	
• signal range	4 to 20 mA (\pm 0.02 mA accuracy) upper limit 20 to 22.6 mA adjustable
• fail signal	3.6 mA to 22.6 mA (see <i>Fail-safe Mode</i> on page 132 for more details)
Communication: HART	
• Load	230 to 600 Ω , 230 to 500 Ω when connecting a coupling module
• Max. Line Length	multi-wire: \leq 1500 m (4921 ft)
• Protocol	HART, Version 5.1
Configuration	
• remote	Siemens SIMATIC PDM or AMS Device Manager (PC)
• local	Siemens infrared handheld programmer, or HART handheld communicator
Display (local) ²⁾	graphic LCD, with bar graph representing level

Mechanical

Process Connections:	
• threaded connection	
- polypropylene rod antenna	1.5" NPT (ANSI/ASME B1.20.1), R (BSPT, EN 10226-1) or G (BSPP, EN ISO 228-1)
- PTFE antenna, SS connection	2" NPT (ANSI/ASME B1.20.1), R (BSPT, EN 10226-1) or G (BSPP, EN ISO 228-1)

¹⁾ Reference conditions: **Response Rate (2.4.1.)** set to **FAST**, **LCD Fast Mode (4.9.)** set to **ON**.

²⁾ Display quality will be degraded in temperatures below -25 °C (-13 °F) and above $+65$ °C ($+149$ °F).

- flange connection (flat-face)
 - 2", 3", 4" (ASME 150 lb, 300 lb)
 - DN50, DN80, DN100, DN150, DN200 (PN16, PN40)
 - 50A, 80A, 100A (JIS 10K)
 - materials
 - 316 L/1.4404 stainless steel
 - or 316 L/1.4435 stainless steel
 - flange connection (raised face)
 - DN80, DN100, DN150 (PN16, PN40) per EN 1092-1 B1
 - DN200 (PN16) per EN 1092-1 B1
 - 1.4404 or 1.4435 stainless steel
 - materials
- Antenna:
- polypropylene rod
 - hermetically sealed construction
 - standard 100 mm (4") shield for maximum 100 mm (4") nozzle, or optional 250 mm (10") long shield
 - PTFE rod
 - see *Appendix G: Flange Adapter Versions* on page 152
 - horns/waveguide
 - see *Appendix G: Flange Adapter Versions* on page 152
- Enclosure
- construction
 - aluminum, polyester powder-coated
 - conduit entry
 - 2 x M20x1.5, or 2 x ½" NPT
 - ingress protection
 - Type 4X/NEMA 4X, Type 6/NEMA 6, IP 67, IP68 (see note below)
- Weight (excluding extensions)
- 100 mm threaded polypropylene rod antenna
 - approx. 3.5 kg (7.7 lb)
 - DN50/PN16 or 2" ASME 150 lb flat-face flange, rod or horn
 - approx. 8 kg (17.6 lb)
 - DN100/PN16 or 4" ASME 150 lb flat-face flange, rod or horn
 - approx. 10.5 kg (23.1 lb)
 - DN200/PN16 or 8" ASME 150 lb flat-face flange, rod or horn
 - approx. 19 kg (41.8 lb)
 - DN100/PN16 raised-face flange, rod or horn
 - approx. 10 kg (22 lb)
 - DN200/PN16 raised-face flange, rod or horn
 - approx. 20.8 kg (45.9 lb)

Environmental

Notes:

- Check *Approvals* on page 9, for the specific configuration you are about to use or install.
- Use appropriate conduit seals to maintain IP or NEMA rating.

- location
 - indoor/ outdoor
- altitude
 - 5000 m (16,404 ft) max.

- ambient temperature –40 to +80 °C (–40 to +176 °F)
- relative humidity suitable for outdoor
Type 4X/NEMA 4X, Type 6/NEMA 6, IP67, IP68 enclosure (see note below)
- installation category I
- pollution degree 4

Process

- process temperature¹⁾
 - polypropylene rod –40 to +80 °C (–40 to +176 °F)
 - PTFE rod or SS horn –40 to +200 °C (–40 to +392 °F)
- pressure (vessel)¹⁾ 3 bar, gauge (43.5 psi, gauge)

Approvals

Note: The device nameplate lists the approvals that apply to your device.

- General CSA_{US/C}, FM, CE, C-TICK
- Radio Europe (R&TTE), FCC, Industry Canada
- Hazardous Intrinsically Safe²⁾:
 - (Europe) ATEX II 1 G Ex ia IIC T4 Ga
 - (International) IECEx SIR 13.0006X, Ex ia IIC T4 Ga
 - (US/Canada) FM/CSA:
Class I, Div. 1, Groups A, B, C, D
Class II, Div. 1, Groups E, F, G
Class III T4
 - (Brazil) INMETRO: DNV 12.0143 X
Ex ia IIC T4 Ga
DNV #OCP 0017
ABNT NBR IEC 60079-0:2008,
ABNT NBR IEC 60079-11:2009 e
ABNT NBR IEC 60079-26:2008
 - (China) NEPSI Ex ia IIC T4 Ga
- Non-sparking³⁾
 - (Europe) ATEX II 3 G Ex nA IIC T4 Gc
 - (China) NEPSI Ex nA IIC T4 Gc

¹⁾ The maximum temperature is dependent on the process connection, antenna materials, and vessel pressure. For more detail, or for other configurations, see *Maximum Process Temperature Chart* on page 133, and *Process Pressure/Temperature derating curves* on page 134 onwards.

²⁾ See *Intrinsically Safe wiring* on page 21.

³⁾ See *Non-Sparking wiring* on page 23 for more details.

Non-incendive (US) ¹⁾	FM: Class I, Div. 2, Groups A, B, C, D T5
Flameproof (Europe) ²⁾ (China)	ATEX II 1/2 G Ex d mb ia IIC T4 Ga/Gb NEPSI Ex d ia mb IIC T4 Ga/Gb
Increased Safety (Europe) ³⁾ (China)	ATEX II 1/2 G Ex e mb ia IIC T4 Ga/Gb NEPSI Ex e ia mb IIC T4 Ga/Gb
Explosion proof (US/Canada) ⁴⁾	FM/CSA: Class I, Div. 1, Groups A, B, C, D Class II, Div. 1, Groups E, F, G Class III T4
• Marine	Lloyd's Register of Shipping ABS Type Approval

¹⁾ See *Non-incendive wiring (FM US only)* on page 23.

²⁾ See *Flameproof wiring* on page 23.

³⁾ See *Increased safety wiring* on page 24.

⁴⁾ See *Explosion-proof wiring (FM/CSA US/Canada only)* on page 24.

Programmer (infrared keypad)

Notes:

- Battery is non-replaceable with a lifetime expectancy of 10 years in normal use.
- To estimate the lifetime expectancy, check the nameplate on the back for the serial number. The first six numbers show the production date (mmddyy), for example, serial number 032608101V.

Siemens Milltronics Infrared IS (Intrinsically Safe) Handheld Programmer for hazardous and all other locations.

- approvals FM/CSA Class I, II, III, Div. 1, Gr. A to G T6
CE
ATEX II 1GD Ex ia IIC T4 Ga
Ex iaD 20 T135 °C
FM/CSA Class I, II, III, Div. 1, Gr. A to G T6
IECEx SIR 09.0073 Ex ia IIC T4 Ga
Ex iaD 20 T135 °C
INMETRO DNV 12.0075
Ex ia IIC T4 Ga
Ex ia IIIC T135 °C Da
DNV #OCP 0017
ABNT NBR IEC 60079-0:2008,
ABNT NBR IEC 60079-11:2009,
ABNT NBR IEC 60079-26:2008 e IEC 61241-11:2005
- ambient temperature –20 to +50 °C (–5 to +122 °F)
- interface proprietary infrared pulse signal
- power 3 V lithium battery
- weight 150 g (0.3 lb)
- color black
- Part Number 7ML1930-1BK

Dimensions: Uni-Construction Polypropylene Rod Antenna

Specifications

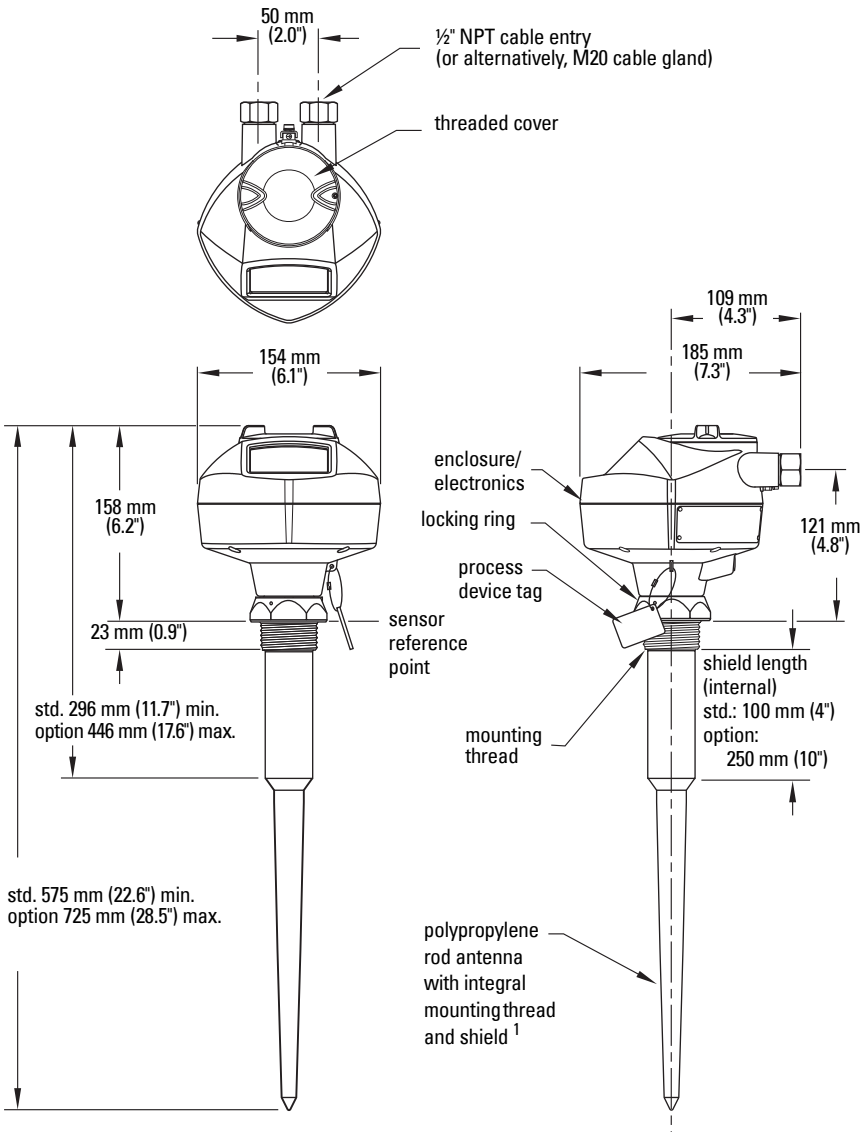

¹⁾ The shield is the area of the rod which is inactive. The shield length must be longer than the vessel nozzle height.

Threaded Connection Markings

Threaded connection markings are found on the flat face/faces of the process connection.

Serial number: a unique number allotted to each process connection, including the date of manufacture (MMDDYY) followed by a number from 001 to 999.

Installation



• WARNINGS:

- **Handle the device using the enclosure, not the antenna or the device tag, to avoid damage.**
- **Installation shall only be performed by qualified personnel and in accordance with local governing regulations.**
- **SITRANS LR200 is to be used only in the manner outlined in this manual, otherwise protection provided by the device may be impaired.**
- **Never attempt to loosen, remove, or disassemble process connection or instrument housing while vessel contents are under pressure.**
- **Materials of construction are chosen based on their chemical compatibility (or inertness) for general purposes. For exposure to specific environments, check with chemical compatibility charts before installing.**
- **The user is responsible for the selection of bolting and gasket materials which will fall within the limits of the flange and its intended use and which are suitable for the service conditions.**
- **Improper installation may result in loss of process pressure.**

Notes:

- Refer to the device nameplate for approval information.
- The Process Device Tag shall remain with the process pressure boundary assembly¹. In the event the instrument package is replaced, the Process Device Tag shall be transferred to the replacement unit.
- SITRANS LR200 units are hydrostatically tested, meeting or exceeding the requirements of the ASME Boiler and Pressure Vessel Code and the European Pressure Equipment Directive.
- The serial numbers stamped in each process connection body provide a unique identification number indicating date of manufacture.
Example: MMDDYY – XXX (where MM = month, DD = day, YY = year, and XXX= sequential unit produced)
Further markings (space permitting) indicate flange configuration, size, pressure class, material, and material heat code.

¹⁾ The process pressure boundary assembly comprises the components that act as a barrier against pressure loss from the process vessel: that is, the combination of process connection body and emitter, but normally excluding the electrical enclosure.

Pressure Equipment Directive, PED, 97/23/EC

Siemens Level Transmitters with flanged, threaded, or sanitary clamp type process mounts have no pressure-bearing housing of their own and, therefore, do not come under the Pressure Equipment Directive as pressure or safety accessories, (see EU Commission Guideline 1/8).

Mounting location

Notes:

- Correct location is key to a successful application.
- Avoid reflective interference from vessel walls and obstructions by following the guidelines below

Nozzle design

Notes:

- For nozzles 100 mm (4") in length or shorter use the 100 mm (4") shield.
- For nozzles 250 mm (10") in length or shorter use the 250 mm (10") shield.
- For details on other applications, see *Appendix G: Flange Adapter Versions* on page 152.
- The end of the shield section should protrude a minimum of 10 mm (0.4") to avoid false echoes being reflected from the nozzle.

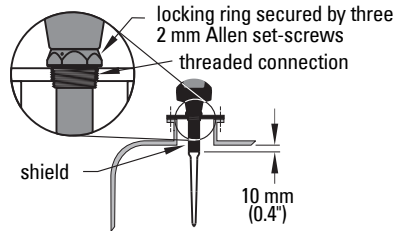

Location on a manhole cover

- A manhole cover is typically a covered nozzle with a diameter 610 mm (24") or greater.
- For optimum signal conditions, locate the antenna off-center, typically 100 mm (4") from the side.

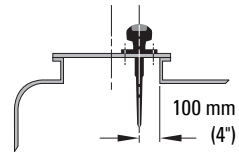

Nozzle location

! **WARNING: For vessels with conical or parabolic tops, avoid mounting the instrument at the centre. (The concavity of the top can focus echoes into the centre, giving false readings.)**

Note: Under certain circumstances, it may be acceptable to mount SITRANS LR200 at the centre of a flat-topped tank: please discuss this with your Siemens Milltronics Representative.

- Avoid central locations on vessels

✓✓ preferred
⊘ undesirable

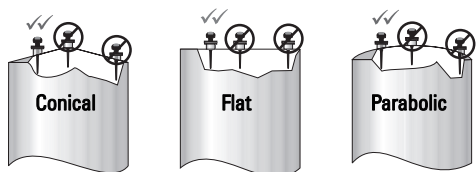

Nozzle location (continued)

Beam angle

- Beam angle is the width of the cone where the energy density is half of the peak energy density.
- The peak energy density is directly in front of and in line with the rod antenna.
- There is a signal transmitted outside the beam angle, therefore false targets may be detected.

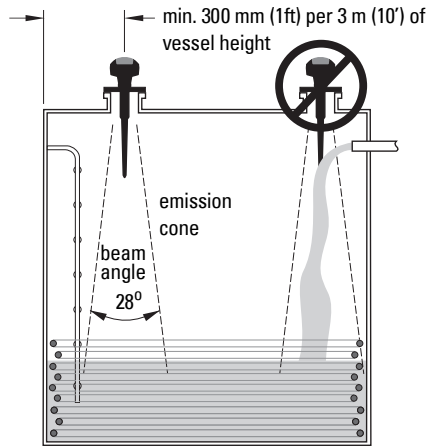

Emission cone

- Keep emission cone free of interference from ladders, pipes, I-beams or filling streams.
- Locate the antenna away from the side wall, to avoid interference from indirect echoes.
- Make allowance for the emission cone spreading: allow a minimum of 300 mm (1 ft) for every 3 m (10 ft) of vessel height.

Environment

- Provide an environment suitable to the housing rating and materials of construction.
- Maintain ambient temperature within -40 to $+80$ °C (-40 to $+176$ °F)¹⁾.
- Use a sunshield if the instrument will be exposed to direct sunlight.

Access for programming

- Provide easy access for viewing the display and programming via the handheld programmer.

ambient temperature (surrounding enclosure volume)
 -40 to $+80$ °C (-40 to $+176$ °F)

handheld programmer

display

process temperature (polypropylene rod² only)
 -40 to 80 °C (-40 to 176 °F)

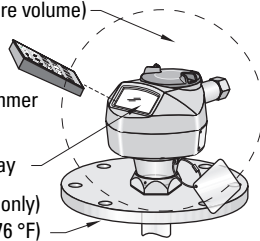

¹⁾ For more detail on maximum interface and process temperatures, see *Maximum Process Temperature Chart* on page 133.

²⁾ For other configurations, see *Maximum Process Temperature Chart* on page 133, and *Process Pressure/Temperature derating curves* on page 134.

Orientation in a vessel with obstructions

Polarization reference point

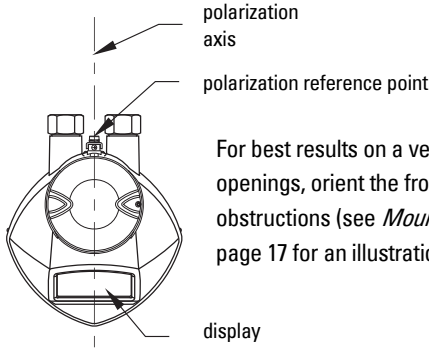

For best results on a vessel with obstructions, or a stillpipe with openings, orient the front or back of the device toward the obstructions (see *Mounting on a Stillpipe or Bypass Pipe* on page 17 for an illustration).

Mounting on a Stillpipe or Bypass Pipe

Note: See *Device orientation* on page 18.

A stillpipe or bypass is used for products with a low dK^1 , or when vortex or extremely turbulent conditions exist. It can also be used to provide optimum signal conditions on foaming materials.

Stillpipe or Bypass Pipe requirements

- The pipe diameter must be matched with the horn size. Use the largest horn size that will fit the stillpipe/bypass pipe (see *Flanged Horn dimensions* on page 156).
- Suitable pipe diameters: 50 mm (2") to 200 mm (8").
- One continuous length of metallic pipe is preferred, without joints².
- Joints (if unavoidable) must be machined to ± 0.25 mm (± 0.010 ") and must have a welded connecting sleeve on the outside.
- Bypass vent required at the upper end of the bypass³
- Propagation factor. depends on pipe diameter. See **Propagation Factor (2.8.3)** on page 87 for a table.

¹) See *Dielectric constant of material measured* on page 7.

²) Bad joints create reflections.

³) To equalize pressure and keep the liquid level in the bypass constant with the liquid level in the vessel.

Device orientation

Bypass Installation

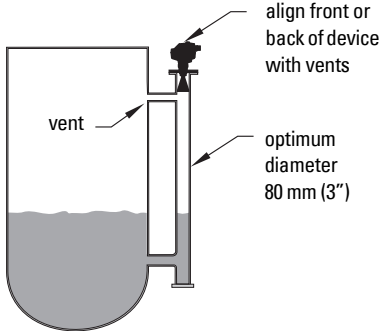

Stillpipe Installation

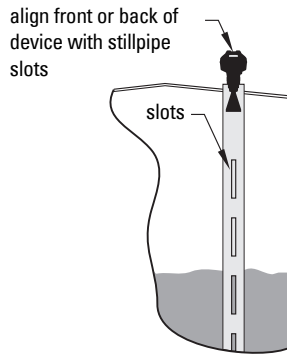

Installation Instructions

Notes:

- There is no limit to the number of times the device can be rotated without damage.
- When mounting, orient the front or back of the device towards the closest wall. For an illustration of a stillpipe application see *Mounting on a Stillpipe or Bypass Pipe* on page 17.
- Do not rotate the enclosure after programming and device configuration, otherwise an error may occur, caused by a polarity shift of the transmit pulse.

1. Before inserting SITRANS LR200 into its mounting connection, check to ensure the threads are matching, to avoid damaging them.
2. Simply screw SITRANS LR200 into the process connection, and hand tighten. For pressure applications, it will be necessary to use PTFE tape (or other appropriate thread sealing compound) and tighten the process connection beyond hand tight. The maximum torque is 40 N·m (30 ft.lbs).
3. If you want to rotate the enclosure, use a 2 mm Allen key to loosen the set-screws that secure the locking ring¹⁾.
4. Once the enclosure is in a suitable position, tighten the set-screws.

locking ring¹⁾
over threaded
connection;
secured by 3
2 mm Allen set-
screws

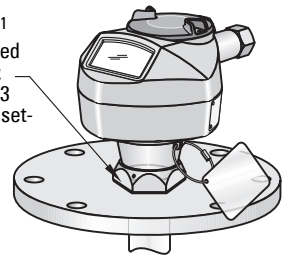

¹⁾ When the locking ring is secured, it prevents the enclosure rotating on the threaded connection.

Wiring

Power

WARNINGS:



The DC input terminals shall be supplied from a source providing electrical isolation between the input and output, in order to meet the applicable safety requirements of IEC 61010-1.



All field wiring must have insulation suitable for rated voltages.

Connecting SITRANS LR200



WARNINGS:

- Check the nameplate on your instrument, to verify the approval rating.
- Use appropriate conduit seals to maintain IP or NEMA rating.
- See *Wiring setups for hazardous area installations* on page 21.

Notes:

- Use twisted pair cable: AWG 22 to 14 (0.34 mm² to 2.5 mm²).
- Separate cables and conduits may be required to conform to standard instrumentation wiring practices or electrical codes.

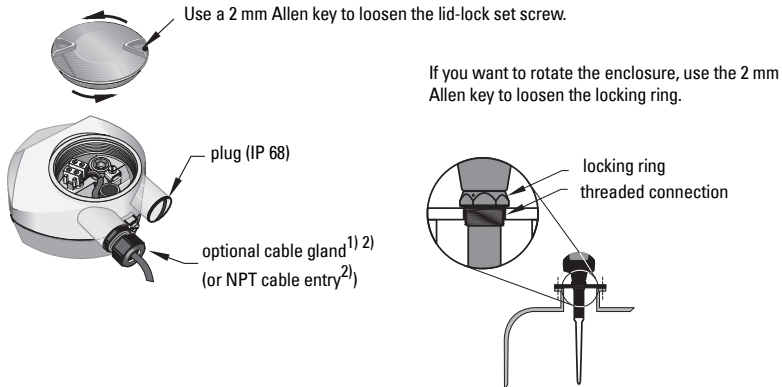

- 1) Strip the cable jacket for approximately 70 mm (2.75") from the end of the cable, and thread the wires through the gland²⁾.

1) May be shipped with the device.

2) If cable is routed through conduit, use only approved suitable-size hubs for waterproof applications.

- 2) Connect the wires to the terminals as shown: the polarity is identified on the terminal block.
- 3) Ground the instrument according to local regulations.
- 4) Tighten the gland to form a good seal.
- 5) Close the lid and secure the locking ring before programming and device configuration

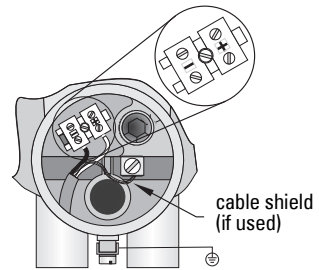

Connecting HART

Typical PLC/mA configuration with HART

Notes

- Depending on the system design, the power supply may be separate from the PLC, or integral to it.
- HART resistance (total of loop resistance, that is, cable resistance plus 250 Ohm [resistor]) must be limited according to the allowable operating area as shown in either *Curve 1 (General Purpose, Intrinsically Safe, Non-Sparking, Non-incendive)* on page 139 or *Curve 2 (Flameproof, Increased Safety, Explosion-proof)* on page 140.
- Do not connect more than one HART programming device at a time.

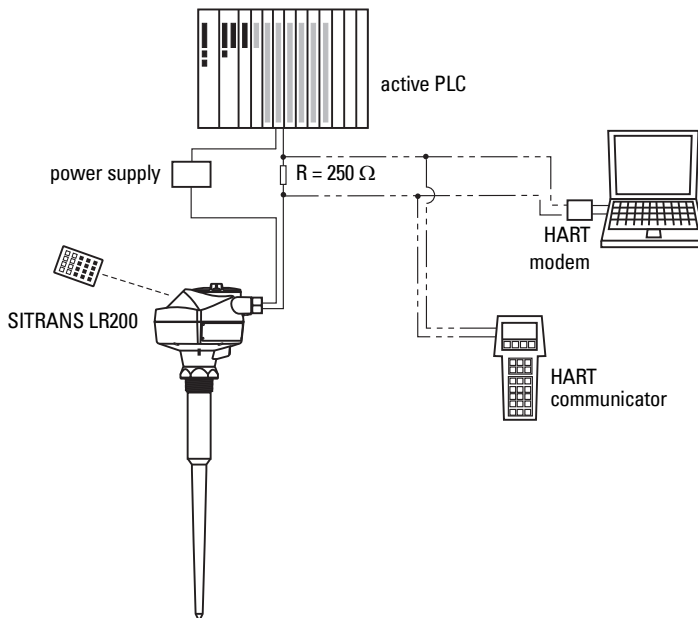

Wiring setups for hazardous area installations

There are six wiring options for hazardous area installations.

In all cases, check the nameplate on your instrument, and confirm the approval rating.

1. Intrinsically Safe wiring

Device nameplate (ATEX/IECEX/INMETRO/C-TICK)

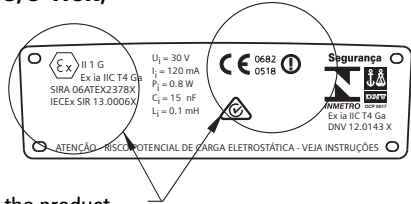
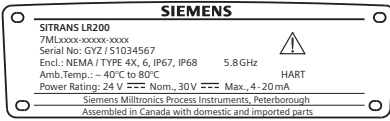

The ATEX certificate can be downloaded from the product page of our website at: www.siemens.com/LR200. Go to **Support > Approvals / Certificates**. The IECEx certificate listed on the nameplate can be viewed on the IECEx website. Go to: <http://iecex.iec.ch> and click on **Ex Equipment Certificates of Conformity** then enter the certificate number IECEx SIR 13.0006X.

Device nameplate (FM/CSA)

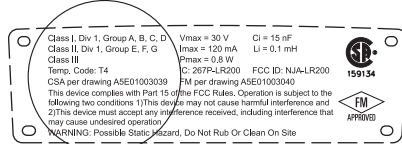
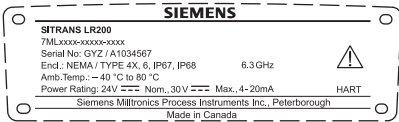

FM Intrinsically Safe connection drawing number **A5E01003040** and CSA Intrinsically Safe connection drawing number **A5E01003039** can be downloaded from the product page of our website at: www.siemens.com/LR200. Go to **Support > Installation Drawings > Level Measurement > Continuous - Radar**.

- For power demands see *Curve 1 (General Purpose, Intrinsically Safe, Non-Sparking, Non-incendive)* on page 139.
- For wiring requirements: follow local regulations.
- Approved dust-tight and water-tight conduit seals are required for outdoor NEMA 4X / type 4X / NEMA 6, IP67, IP68 locations.
- Refer to *Instructions specific to hazardous area installations* on page 25.
- Recommended intrinsically safe barriers are listed under *Passive Shunt Diode Barriers* on page 22 and *Active barriers (repeating barriers)* on page 22.

Note: Selecting a suitable PLC input module, power supply, or barrier requires knowledge about Intrinsic Safety and the application. It is the responsibility of the installer to ensure that the intrinsically safe installation complies with both the apparatus approval requirements and the relevant national code of practice.

Passive Shunt Diode Barriers

Note: A well regulated supply voltage is required.

Manufacturer	Part Number
MTL	787SP+ (Dual Channel)
MTL	7787P+ (Dual Channel)
Stahl	9001/01-280-100-10 (Single Channel)
Stahl	9002/01-280-110-10 (Dual Channel)

How to select a passive barrier for SITRANS LR200

To make sure that the barrier safety description is suitable for the LR200 Intrinsically Safe (IS) input parameters, carry out the following calculations:

- Re-e = max. end-to-end resistance of the barrier
Rloop = loop resistance (total of cable resistance plus any additional series resistance, for example, PLC inputs and/or displays)
Vbarrier = value of any non-linear voltage drops due to the barrier

- 1) Determine the value for Re-e from the data sheet.
- 2) Calculate the total value for Rloop.
- 3) Calculate $R_{working} = Re-e + R_{loop}$.
- 4) Determine the value of Vbarrier from the barrier data sheet (for example, voltage drops due to diodes).
- 5) Calculate $V_{working} = V_{supply} - V_{barrier}$.

Use the values for $V_{working}$ and $R_{working}$ to confirm that operation is within the shaded area of the graph *Curve 1 (General Purpose, Intrinsically Safe, Non-Sparking, Non-incendive)* on page 139.

Active barriers (repeating barriers)

Manufacturer	Part Number
MTL	706
MTL	7206
Siemens	SITRANS I 7NG4122
Stahl	9001/51-280-110-14
MTL	E02009
MTL	E02010

2. Non-Sparking wiring

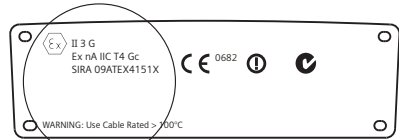
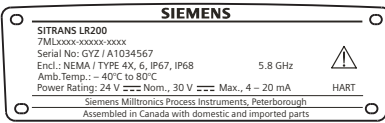

The ATEX certificate listed on the nameplate can be downloaded from the product page of our website at: www.siemens.com/LR200.

Go to: **Support > Approvals / Certificates.**

- For power demands see *Curve 1 (General Purpose, Intrinsically Safe, Non-Sparking, Non-incendive)* on page 139.
- For wiring requirements follow local regulations.
- Refer to *Instructions specific to hazardous area installations* on page 25.

3. Non-incendive wiring (FM US only)

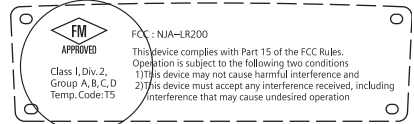
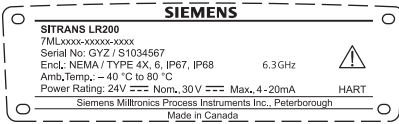

FM Class 1, Div 2 connection drawing number

23650537 can be downloaded from the product page of our website at:

www.siemens.com/LR200. Go to **Support > Installation Drawings > Level Measurement > Continuous - Radar.**

- For power demands see *Curve 1 (General Purpose, Intrinsically Safe, Non-Sparking, Non-incendive)* on page 139.

4. Flameproof wiring

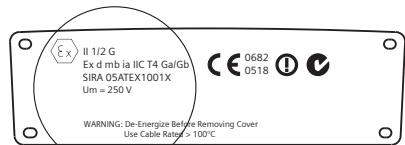
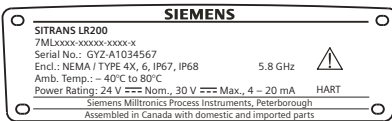

The ATEX certificate can be downloaded from the product page of our website at: www.siemens.com/LR200. Go to **Support > Approvals / Certificates.**

- For power demands see *Curve 2 (Flameproof, Increased Safety, Explosion-proof)* on page 140.
- For wiring requirements follow local regulations.
- Refer to *Instructions specific to hazardous area installations* on page 25.

5. Increased safety wiring

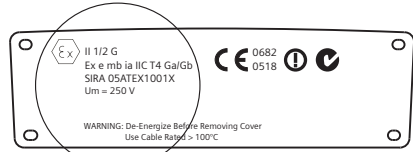
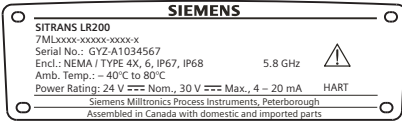

The ATEX certificate can be downloaded from the product page of our website at: www.siemens.com/LR200. Go to **Support > Approvals / Certificates**.

- For power demands see *Curve 2 (Flameproof, Increased Safety, Explosion-proof)* on page 140.
- For wiring requirements follow local regulations.
- Refer to *Instructions specific to hazardous area installations* on page 25.

6. Explosion-proof wiring (FM/CSA US/Canada only)

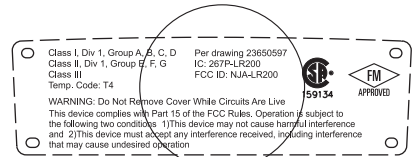
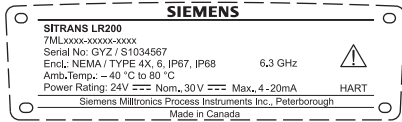

FM/CSA Explosion Proof connection drawing number **23650597** can be downloaded from the product page of our website at: www.siemens.com/LR200. Go to **Support > Installation Drawings > Level Measurement > Continuous - Radar**.

- For power demands see *Curve 2 (Flameproof, Increased Safety, Explosion-proof)* on page 140.
- For wiring requirements (North America only) see the connection drawing listed above.

Instructions specific to hazardous area installations

(Reference European ATEX Directive 94/9/EC, Annex II, 1/0/6)

The following instructions apply to equipment covered by certificate numbers SIRA 06ATEX2378X, SIRA 05ATEX1001X, and SIRA 09ATEX4151X:

- 1) For use and assembly, refer to the main instructions.
- 2) The equipment is certified for use as Category 1G equipment per SIRA 06ATEX2378X, Category 1/2 equipment per SIRA 05ATEX1001X, and Category 3G equipment per SIRA 09ATEX4151X.
- 3) The equipment may be used with flammable gases and vapors with apparatus group IIC, IIB, and IIA, and temperature classes T1, T2, T3, and T4.
- 4) The equipment is certified for use in an ambient temperature range of $-40\text{ }^{\circ}\text{C}$ to $+80\text{ }^{\circ}\text{C}$.
- 5) The equipment has not been assessed as a safety related device (as referred to by Directive 94/9/EC Annex II, clause 1.5).
- 6) Installation and inspection of this equipment shall be carried out by suitably trained personnel in accordance with the applicable code of practice (EN 60079-14 and EN 60079-17 in Europe).
- 7) The equipment is non-repairable.
- 8) The certificate numbers have an 'X' suffix, which indicates that special conditions for safe use apply. Those installing or inspecting this equipment must have access to the certificates.)
- 9) If the equipment is likely to come into contact with aggressive substances, then it is the responsibility of the user to take suitable precautions that prevent it from being adversely affected, thus ensuring that the type of protection is not compromised.
 - Aggressive substances :e.g. acidic liquids or gases that may attack metals, or solvents that may affect polymeric materials.
 - Suitable precautions: e.g. establishing from the material's data sheet that it is resistant to specific chemicals.

Operating via the handheld programmer

SITRANS LR200 carries out its level measurement tasks according to settings made via parameters. The settings can be modified locally via the Local User Interface (LUI) which consists of an LCD display and a handheld programmer.

A Quick Start Wizard provides an easy step-by-step procedure to configure the device for a simple application. There are two ways to access the wizard:

- locally (see *Quick Start Wizard via the handheld programmer* on page 31)
- from a remote location (see *Quick Start Wizard via SIMATIC PDM* on page 37, or *Quick Start Wizard via AMS Device Manager* on page 59)

For more complex setups see *Appendix E: Application Examples* on page 141, and for the complete range of parameters see *Parameter Reference* on page 75.

Activating SITRANS LR200

Power up the instrument. SITRANS LR200 automatically starts up in Measurement mode. A transition screen showing the current firmware revision and an incrementing line of stars is displayed while the first measurement is being processed.

Press **Mode**  to toggle between Measurement and Program Mode.

The LCD Display

Measurement mode display

Normal operation

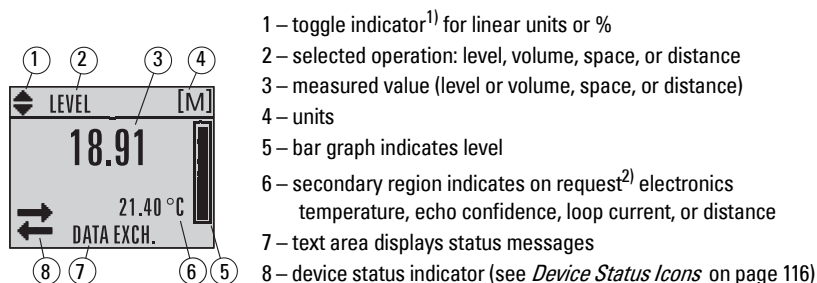

Fault present



S: 0 LOE

- 7 – text area displays a fault code and an error message
 8 – service required icon appears

¹⁾ Press **UP** or **DOWN** arrow to switch.

²⁾ In response to a key press request. For details, see *Key functions in Measurement mode* on page 27.

PROGRAM mode display

Navigation view

- A visible menu bar indicates the menu list is too long to display all items.
- A band halfway down the menu bar indicates the current item is halfway down the list.
- The depth and relative position of the item band on the menu bar indicates the length of the menu list, and approximate position of the current item in the list.
- A deeper band indicates fewer items.

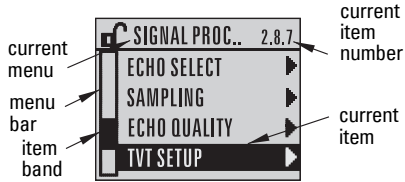

Parameter view

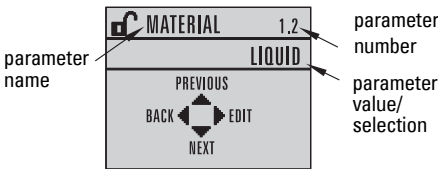

Edit view

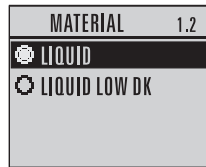

Handheld Programmer





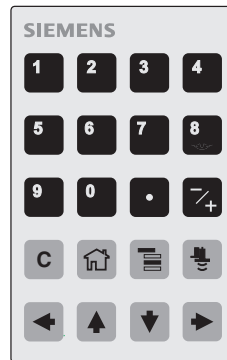

(Part No. 7ML1930-1BK)

The programmer is ordered separately.



Key functions in Measurement mode

Key	Function	Result
5	Updates the loop current.	New value is displayed in LCD secondary region.
6	Updates internal enclosure temperature reading.	

Key	Function	Result (cont'd)
	Updates echo confidence value.	New value is displayed in LCD secondary region.
	Updates distance measurement.	
	Mode opens PROGRAM mode.	Opens the menu level last displayed in this power cycle, unless power has been cycled since exiting PROGRAM mode or more than 10 minutes have elapsed since PROGRAM mode was used. Then top level menu will be displayed.
	RIGHT arrow opens PROGRAM mode.	Opens the top level menu.
 	UP or DOWN arrow toggles between linear units and percent.	LCD displays measured value in either linear units or percent.

Programming SITRANS LR200

Notes:

- While the device is in PROGRAM mode the output remains fixed and does not respond to changes in the device.
- SITRANS LR200 automatically returns to Measurement mode after a period of inactivity in PROGRAM mode (between 15 seconds and 10 minutes, depending on the menu level).

Change parameter settings and set operating conditions to suit your specific application. (For remote operation see *Operating via SIMATIC PDM* on page 35 or *Operating via AMS Device Manager* on page 56.)



Parameter menus

Note: For the complete list of parameters with instructions, see *Parameter Reference* on page 75.

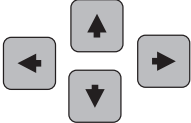
Parameters are identified by name and organized into function groups (see *LCD menu structure* on page 179).

- 
1. QUICK START
 2. SETUP
 - 2.1. DEVICE
 -
 - 2.7. LINEARIZATION
 - 2.7.1. VOLUME
 - 2.7.1.1. VESSEL SHAPE

1. Enter PROGRAM mode



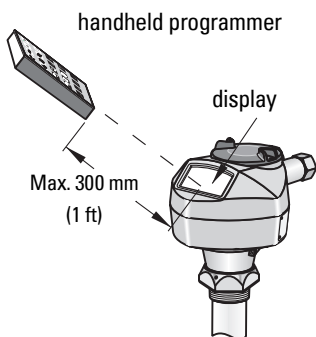



- Point the programmer at the display from a maximum distance of 300 mm (1 ft).
- RIGHT arrow**  activates PROGRAM mode and opens menu level 1.
- Mode**  opens the menu level last displayed in PROGRAM mode within the last 10 minutes, or menu level 1 if power has been cycled since then.



2. Navigating: key functions in Navigation mode

Notes:

- In Navigation mode **ARROW** keys move to the next menu item in the direction of the arrow.
- For Quick Access to parameters via the handheld programmer, press **Home** , then enter the menu number, for example: **2.7.1** (Volume).

Key	Name	Menu level	Function
 	UP or DOWN arrow	menu or parameter	Scroll to previous or next menu or parameter.
	RIGHT arrow	menu	Go to first parameter in the selected menu, or open next menu.
		parameter	Open Edit mode.
	LEFT arrow	menu or parameter	Open parent menu.
	Mode	menu or parameter	Change to MEASUREMENT mode.
	Home	menu or parameter	Open top level menu: menu 1.

3. Editing in PROGRAM mode

Selecting a listed option

- Navigate to the desired parameter.
- Press **RIGHT arrow**  to open parameter view.

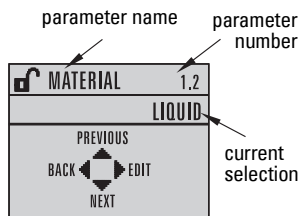

- c) Press **RIGHT arrow**  again to open **Edit** mode. The current selection is highlighted.

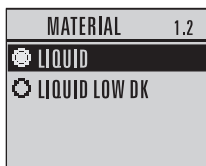



Scroll to a new selection.

- d) Press **RIGHT arrow**  to accept it



The LCD returns to parameter view and displays the new selection.



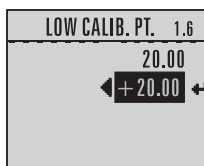
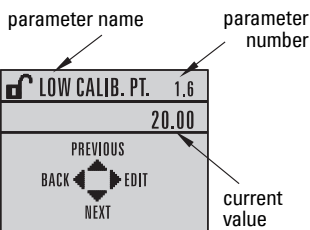

Changing a numeric value

- a) Navigate to the desired parameter.
- b) Press **RIGHT arrow**  to open parameter view. The current value is displayed.
- c) Press **RIGHT arrow**  again to open **Edit** mode. The current value is highlighted.
- d) Key in a new value.
- e) Press **RIGHT arrow**  to accept it. The LCD returns to parameter view and displays the new selection.



Key functions in Edit mode

Key	Name	Function	
	UP or DOWN arrow	Selecting options	Scrolls to item.
		Numeric editing	- Increments or decrements digits - Toggles plus and minus sign
	RIGHT arrow	Selecting options	- Accepts the data (writes the parameter) - Changes from Edit to Navigation mode
		Numeric editing	- Moves cursor one space to the right - or with cursor on Enter sign, accepts the data and changes from Edit to Navigation mode
	LEFT arrow:	Selecting options	Cancels Edit mode without changing the parameter
		Numeric editing	- Moves cursor to plus/minus sign if this is the first key pressed - or moves cursor one space to the left.







Key	Name	Function (cont'd)	
	Clear	Numeric editing	Erases the display.
	Decimal point		Enters a decimal point.
	Plus or minus sign		Changes the sign of the entered value.
 to 	Numeral		Enters the corresponding character.

Quick Start Wizard via the handheld programmer

Notes:

- The Quick Start wizard settings are inter-related and changes apply only after you select **YES** in Apply? (Apply changes) (1.8.).
- Do not use the Quick Start wizard to modify individual parameters: see instead *Parameter Reference* on page 75.

1. Quick Start

- Point the programmer at the display from a maximum distance of 300 mm (1 ft), then press **RIGHT arrow**  to activate PROGRAM mode and open menu level 1.
- Press **RIGHT arrow**  twice to navigate to menu item 1.1 and open parameter view.
- Press **RIGHT arrow**  to open **Edit** mode or **DOWN arrow**  to accept default values and move directly to the next item.
- To change a setting, scroll to the desired item or key in a new value.
- After modifying a value, press **RIGHT arrow**  to accept it and press **DOWN arrow**  to move to the next item.

1.1. Language

Selects the language to be used on the LCD and takes effect immediately.

Options	English, Deutsch, Français, Español
----------------	-------------------------------------

1.2. Material

Selects the appropriate echo processing algorithms for the material (see **Position Detect (2.8.4.2.)** on page 88 for more detail).

Options	LIQUID
	LIQUID LOW DK ^{a)} (low dielectric liquid – CLEF <i>algorithm enabled</i>)

a) $dK < 3.0$

1.3. Response Rate

Sets the reaction speed of the device to measurement changes in the target range.

Options	Response Rate (2.4.1.)	Fill Rate (2.4.2.)/Empty rate (2.4.3.)
	SLOW	0.1 m/min (0.32 ft/min)
	MED	1.0 m/min (3.28 ft/min)
	FAST	10.0 m/min (32.8 ft/min)

Use a setting just faster than the maximum filling or emptying rate (whichever is greater).

1.4. Units

Sensor measurement units.

Options	M, CM, MM, FT, IN
----------------	-------------------

1.5. Operating Mode

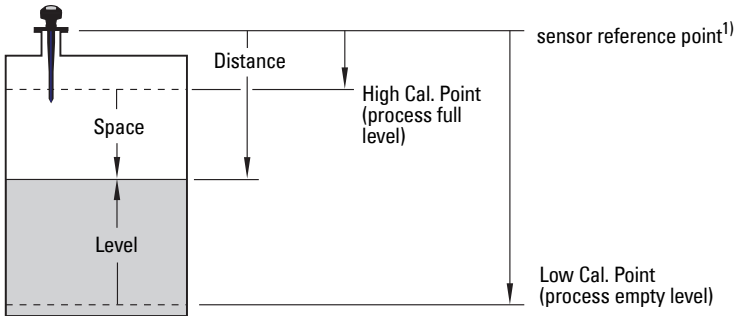

Operating Mode	Description	Reference point
NO SERVICE	Measurement and associated loop current are not updated, and the device defaults to Fail-safe mode ^{a)} .	
LEVEL		Low Calibration Point
SPACE		High Calibration Point
DISTANCE		Sensor Reference Point

a) See **Material Level (2.5.1.)** on page 80 for more detail.

¹⁾ The point from which High and Low Calibration points are referenced: see *Dimensions: Uni-Construction Polypropylene Rod Antenna* on page 12 and *Appendix G: Flange Adapter Versions* on page 152.

1.6. Low Calibration Point

Distance from Sensor Reference to Low Calibration Point: usually process empty level. (See **Operating Mode (1.5.)** for an illustration.)

Values	Range: 0.00 to 20.00 m
---------------	------------------------

1.7. High Calibration Point

Distance from Sensor Reference to High Calibration Point: usually process full level. (See **Operating Mode (1.5.)** for an illustration.)

Values	Range: 0.00 to 20.00 m
---------------	------------------------

1.8. Apply? (Apply changes)

In order to save the Quick Start settings it is necessary to select Yes to apply changes.

Options	YES, NO, DONE (Display shows DONE when Quick Start is successfully completed.)
----------------	---

Press **Mode**  to return to Measurement mode. SITRANS LR200 is now ready to operate.

Auto False Echo Suppression



If you have a vessel with known obstructions, we recommend using Auto False Echo Suppression to prevent false echo detection. See **TVT setup (2.8.7.)** on page 92 for instructions.

This feature can also be used if SITRANS LR200 displays a false high level, or the reading is fluctuating between the correct level and a false high level.

Requesting an Echo Profile

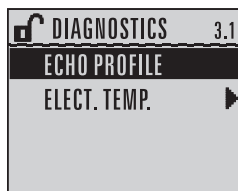
- In PROGRAM mode, navigate to: **Level Meter > Diagnostics (3.) > Echo Profile (3.1.)**
- Press **RIGHT arrow**  to request a profile.



- UP/DOWN arrows** are dedicated to scrolling through the icons.
- The selected icon is highlighted.
- Press **UP arrow** to select **Measure** and **RIGHT arrow**  to update the profile.
- Press **DOWN arrow**  to select **Exit** then press **RIGHT arrow**  to return to the previous menu.

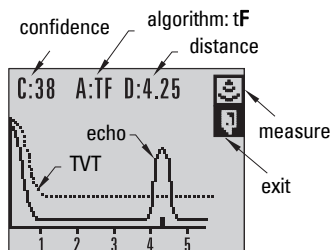

exit icon selected / highlighted



exit icon deselected

Level application example

The application is a vessel that takes an average 3 hours (180 minutes) to fill and 3 weeks to empty.

$$\begin{aligned} \text{Fill rate} &= 0.08 \text{ m/minute } [(\text{Low Cal Pt. minus High Cal Pt.}) / \text{fastest of fill or empty time}] \\ &= (15.5 \text{ m} - 1 \text{ m}) / 180 \text{ min.} \\ &= 14.5 \text{ m} / 180 \text{ min.} = 0.08 \text{ m/min.} \end{aligned}$$

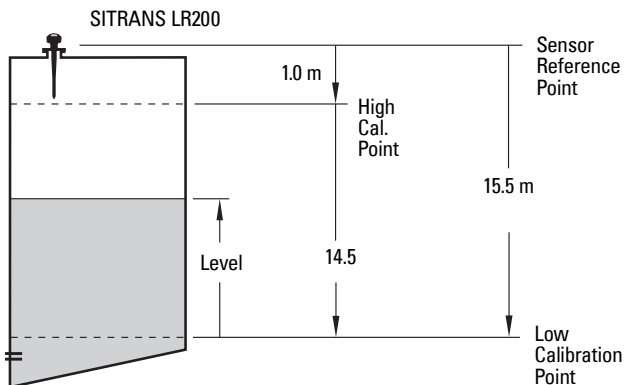

Quick Start Parameter	Setting	Description
Material (1.2.)	LIQUID	
Response Rate (1.3.)	SLOW	Response rate = 0.1 m/minute.
Units (1.4.)	m	
Operating Mode (1.5.)	LEVEL	Material level referenced from Low Cal. Point.
Low Calibration Point (1.6.)	15.5	Process empty level.
High Calibration Point (1.7.)	1.0	Process full level.
Apply? (Apply changes) (1.8.)	YES	Save new settings.

Operating via SIMATIC PDM

SIMATIC PDM is a software package used to commission and maintain SITRANS LR200 and other process devices. Please consult the operating instructions or online help for details on using SIMATIC PDM. (You can find more information at www.siemens.com/simatic-pdm.)

Functions in SIMATIC PDM

Notes:

- For a complete list of parameters see *Parameter Reference* on page 75.
- While the device is in PROGRAM mode the output remains fixed and does not respond to changes in the device.

SIMATIC PDM monitors the process values, alarms and status signals of the device. It allows you to display, compare, adjust, verify, and simulate process device data; also to set schedules for calibration and maintenance.

Parameters are identified by name and organized into function groups. See *LCD menu structure* on page 179 for a chart¹⁾ and *Changing parameter settings using SIMATIC PDM* on page 44 for more details.

See *Parameters accessed via pull-down menus* on page 44 for parameters that do not appear in the menu structure in SIMATIC PDM.

Features of SIMATIC PDM Rev. 6.0, SP4

The graphic interface in SITRANS LR200 makes monitoring and adjustments easy.

Feature	page	Function
Quick Start	38	Device configuration for simple applications
Echo Profile Utilities	45	Easy access to echo profile viewing/comparison, TVT shaping, auto false echo suppression and echo setup
Auto False Echo Suppression	48	Screen out false echoes
TVT Shaper	47	Manual TVT adjustment
Linearization	41	Volume measurement in an irregular vessel
Process Variables	53	Monitor process variables and level trend
Enter a new password and re-enter it in the Confirmation window. Click on OK.	55	Protect security and communication parameters from modification by the maintenance user

¹⁾ The menu structure for SIMATIC PDM is almost identical to that for the LCD.

Features of SIMATIC PDM Rev. 5.2, SP1

SIMATIC PDM Rev. 5.2 SP1 is supported only for basic configuration and troubleshooting. For advanced features such as the Quick Start wizard, Rev. 6.0 SP3 HF2 or higher is required.

Initial Setup

To ensure that SIMATIC PDM connects properly, please complete the two processes outlined below:

- 1) De-activating Buffers
- 2) Updating the Electronic Device Description (EDD)

Deactivating Buffers

This deactivation is required to align SIMATIC PDM with the HART modem for Windows 2000^{®1)} and Windows[®] XP operating Systems.

Notes:

- SIMATIC PDM operates only in the Windows XP Professional version, not in the Home version.
- You need administrative rights on your operating system to deactivate buffers.

- 1) Click **Start/Settings/Control Panel** to begin configuration.
- 2) Double click **System**, select the **Hardware** tab, and click the **Device Manager** button.
- 3) Open **Ports** folder and double click the COM Port used by the system to open the **Communications Port Properties** window.
- 4) Select the **Port Settings** tab and double click the **Advanced** button.
- 5) If the **Use FIFO buffers** radio box is selected, click to deselect.

Deselect **Use FIFO buffers** radio box

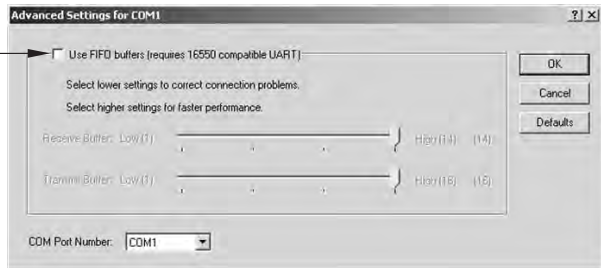

- 6) Click **OK** to close out. Close all screens and then reboot.

1) [®] Windows is a registered trademark of the Microsoft Corporation

Updating the Electronic Device Description (EDD)

You can locate the EDD in Device Catalog, under **Sensors/Level/Echo/Siemens Milltronics/SITRANS LR200**. Check the product page of our website at: www.siemens.com/LR200 to make sure you have the latest version of SIMATIC PDM, the most recent Service Pack (SP) and the most recent hot fix (HF). Go to **Support > Software Downloads**.

To install a new EDD:

- 1) Download the EDD from the product page of our website at www.siemens.com/LR200 and save the files to your computer.
- 2) Extract the zipped file to an easily accessed location.
- 3) Launch **SIMATIC PDM – Manage Device Catalog**, browse to the unzipped EDD file and select it.

Configuring a new device

Note: Clicking on **Cancel** during an upload from device to SIMATIC PDM will result in some parameters being updated.

- 1) Check that you have the most recent EDD and if necessary update it (see *Updating the Electronic Device Description (EDD)* on page 37).
- 2) Launch SIMATIC Manager and create a new project for LR200. Application Guides for setting up HART devices with SIMATIC PDM can be downloaded from the product page of our website at: www.siemens.com/LR200.
- 3) Open the menu **Device – Master Reset** and click on **OK** to perform a reset to Factory Defaults.
- 4) After the reset is complete upload parameters to the PC/PG.
- 5) Configure the device via the Quick Start wizard.

Quick Start Wizard via SIMATIC PDM

The graphic Quick Start Wizard provides an easy 5-step procedure that configures the device for a simple application.

Please consult the operating instructions or online help for details on using SIMATIC PDM.

- 1) If you have not already done so, check that you have the most up-to-date EDD for your instrument. (See *Updating the Electronic Device Description (EDD)* above.)
- 2) Launch SIMATIC Manager and create a new project for LR200. (Application Guides for setting up HART and PROFIBUS PA devices with SIMATIC PDM can be downloaded from the product page of our website at: www.siemens.com/LR200).
- 3) Open the menu **Device – Master Reset** and click on **OK** to perform a reset to Factory Defaults.
- 4) After the reset is complete upload parameters to the PC/PG.
- 5) Configure the device.

Quick Start

Notes:

- The Quick Start wizard settings are inter-related and changes apply only after you click on **FINISH AND DOWNLOAD** at the end of step 5 to save settings offline and transfer them to the device.
- Do not use the Quick Start Wizard to modify individual parameters. For quick access to echo profile parameters see *Echo Setup* on page 50, or see *Parameter Reference* on page 75 for a complete list.
- Click on **BACK** to return and revise settings or **CANCEL** to exit the Quick Start.
- For a vessel with obstructions see *Auto False Echo Suppression* on page 48.

Launch SIMATIC PDM, open the menu **Device – Wizard - Quick Start**, and follow steps 1 to 5.

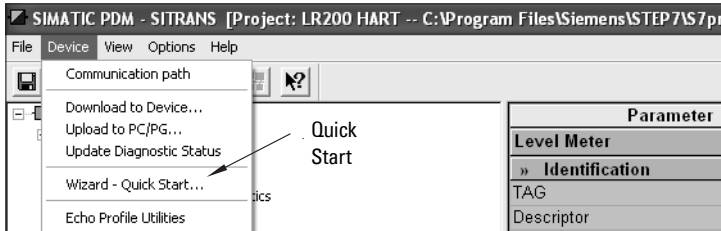

Step 1 – Identification

Note: The layout of the dialog boxes shown may vary according to the resolution setting for your computer monitor.

- 1) Click on **Read Data from Device** to upload Quick Start parameter settings from the device to the PC/PG and ensure PDM is synchronized with the device.
- 2) If required, change the language for the local user interface.
- 3) Click on **NEXT** to accept the default values. (Description, Message, and Installation Date fields can be left blank.)



Step 2 – Application

Select the application type (level or volume) and the material¹⁾, then click on **NEXT**.



Step 3 – Vessel Shape

The vessel shapes shown are predefined. To describe a more complex shape see *Using Linearization via the Quick Start wizard* on page 41.

For a vessel with obstructions, see *Auto False Echo Suppression* on page 48

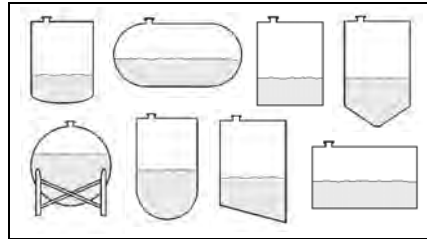

Select the vessel shape, and click on **NEXT**.



¹⁾ See *Application with Stillpipe* on page 146 for a Low Dielectric Liquid application.

Step 4 – Range

Set the parameters, and click on **NEXT**.

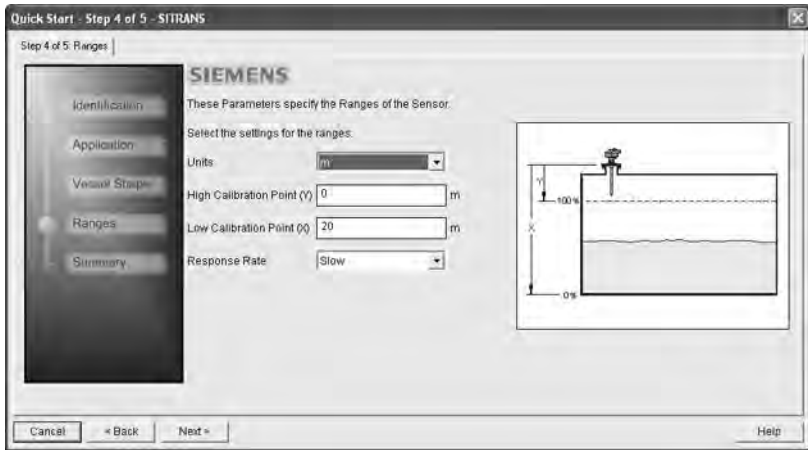

Step 5 – Summary

Check parameter settings, and click on **BACK** to return and revise values, **FINISH** to save settings offline, or **FINISH AND DOWNLOAD** to save settings offline and transfer them to the device.

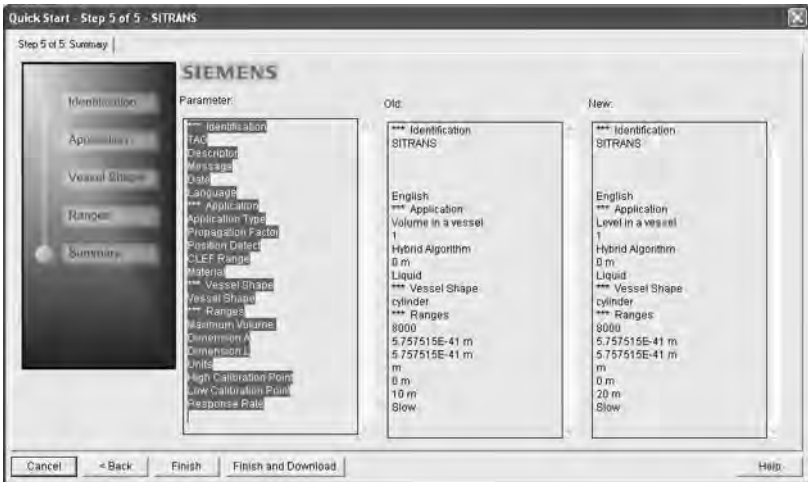

The message **Quick Start was successful** will appear. Click on **OK**.

Linearization

You can use the linearization feature to define a more complex vessel shape and enter up to 32 level breakpoints where the corresponding volume is known. The values corresponding to 100% and 0% levels must be entered. The breakpoints can be ordered from top to bottom, or the reverse.

Example (values for example purposes only)

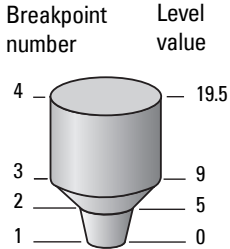

Break-point no.	Level value (m)	Volume value (l)
1	0	0
2	5	500
3	9	3000
4	19.5	8000

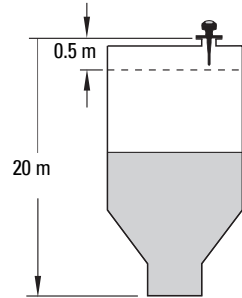

Using Linearization via the Quick Start wizard

Open the menu Device – Wizard - Quick Start:

- 1) In **Step 1 – Identification**, click on **Read Data from Device**, select language, and click on **Next**.
- 2) In **Step 2 – Application**, select a volume application, for example **Volume in a vessel**, and click on **Next**.
- 3) In **Step 3 – Vessel Shape**, choose the vessel shape option **Linearization Table**, and click on **Next**.



4) In Step 4 – Ranges

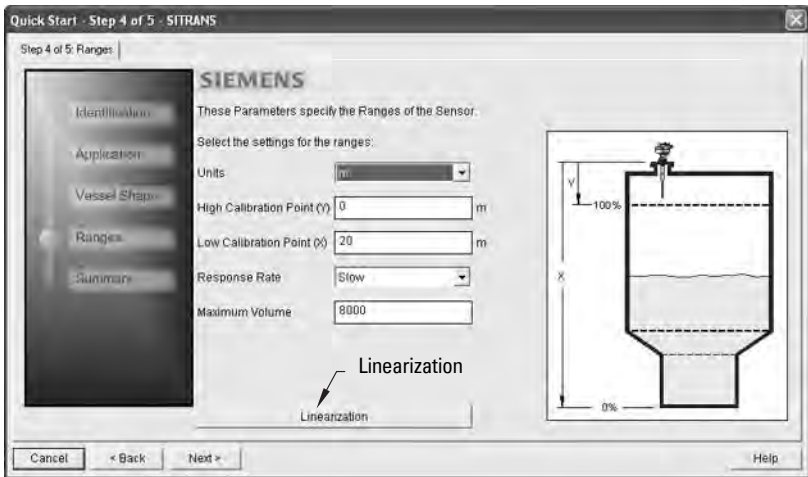

- Enter parameter values.
- Click on **Linearization**.
- In the **Linearization** window click on the appropriate **Breakpoint** tab to open the dialog window.
- Enter the desired level and associated volume values¹⁾, and click on **OK**.

Breakpoints 1 - 8

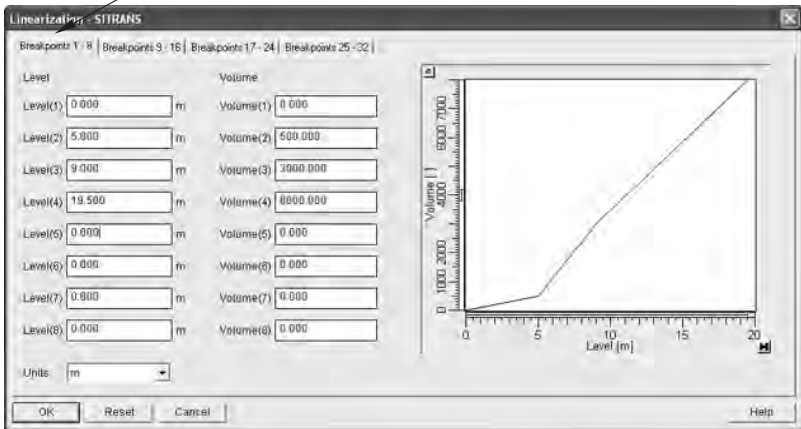

Note: The **Reset** button resets values to the values in the offline table.

- In the Step 4 window, click on **NEXT**.

¹⁾ For display purposes we recommend entering values in ascending order (that is, the lowest values in level 1 and volume 1).

- In **Step 5 – Summary**, check parameter values. Click on **BACK** to return and revise values, **FINISH** to save settings offline, or **FINISH AND DOWNLOAD** to save settings offline and transfer them to the device.

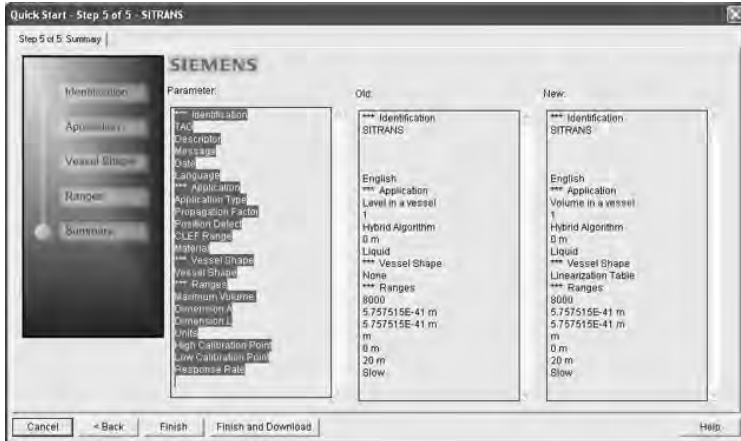

The message **Quick Start was successful** will appear. Click on **OK**.

Configuring a stillpipe application

- Launch the Quick Start wizard and follow steps 1 to 2.
- In step 2, select **Application Type – Level in a vessel with stillpipe**, **Material – Liquid Low dK**, and set the stillpipe diameter as desired.
- The wizard updates the propagation factor according to the pipe diameter, and enables the CLEF algorithm for low dK liquids (see *Position Detect (2.8.4.2.)* on page 125 for more detail).



- Continue through steps 3 to 5 then click on **FINISH AND DOWNLOAD** to save settings offline and transfer them to the device.

Changing parameter settings using SIMATIC PDM

Notes:

- For a complete list of parameters, see *Parameter Reference* on page 75.
- Clicking on **Cancel** during an upload from device to SIMATIC PDM will result in some parameters being updated.

Many parameters are accessed via the 4-level menu in PDM. See *Parameters accessed via pull-down menus* below for the others.

- 1) Launch SIMATIC PDM, connect to SITRANS LR200, and upload data from the device.
- 2) Adjust parameter values in the parameter value field then click on **Enter**. The status fields read **Changed**.
- 3) Open the Device menu, click on **Download to device**, then use **File – Save** to save settings offline. The status fields are cleared.

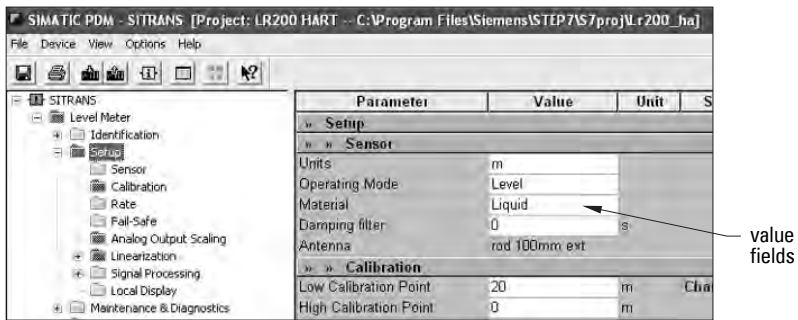

Parameters accessed via pull-down menus

Click on **Device** or **View** to open the associated pull-down menus.

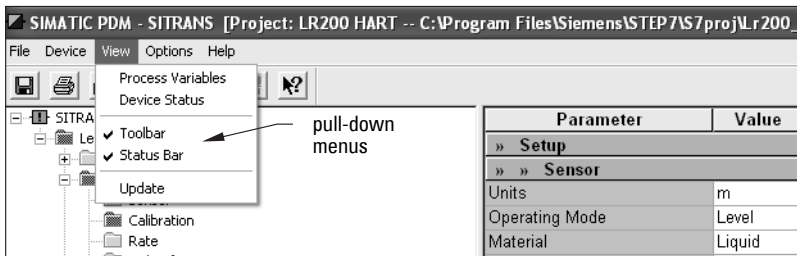

See *Pull-down menus* on page 45 for a table.

Pull-down menus

Device menus	page	View menus	page
Communication path		Process Variables	53
Download to device		Device Status	54
Upload to PC/PG		Toolbar	
Update Diagnostic Status		Status bar	
Wizard - Quick Start	38	Update	
Echo Profile Utilities	45		
Maintenance	50		
Wear	52		
Select Analog Output	51		
Self Test	51		
Loop-Test	52		
Configuration Flag Reset	52		
Master Reset	52		
HART Communication	52		

Echo Profile Utilities

Open the menu **Device – Echo Profile Utilities** and click on the appropriate tab for easy access to:

- *Echo profile* on page 46
- *View Saved Echo Profiles* on page 46
- *TVT Shaper* on page 47
- *Auto False Echo Suppression* on page 48
- *Echo Setup* on page 50

Echo profile

Notes:

- Double click on each axis to see the Xscale and Data Scale values. Right-click or Left-click on the axis and drag to reposition the scale.
- After saving a profile click on **OK**, not the **x** button, to close the Echo Profile Utilities window, otherwise the profile will not be saved.

- In the **Echo Profile Utilities** window click on the tab **Echo Profile**.
- Click on the **Measure** button to update the profile. Select **Standard** resolution (loads 1 of every 8 points of the profile for a quick view) or **Detailed** resolution (loads all data points).
- Click on the **Save** button and in the new window enter a name and click on **OK**.
- Click on **OK** to exit.

View Saved Echo Profiles

To view a saved profile, click on the tab **View Saved Echo Profiles**.

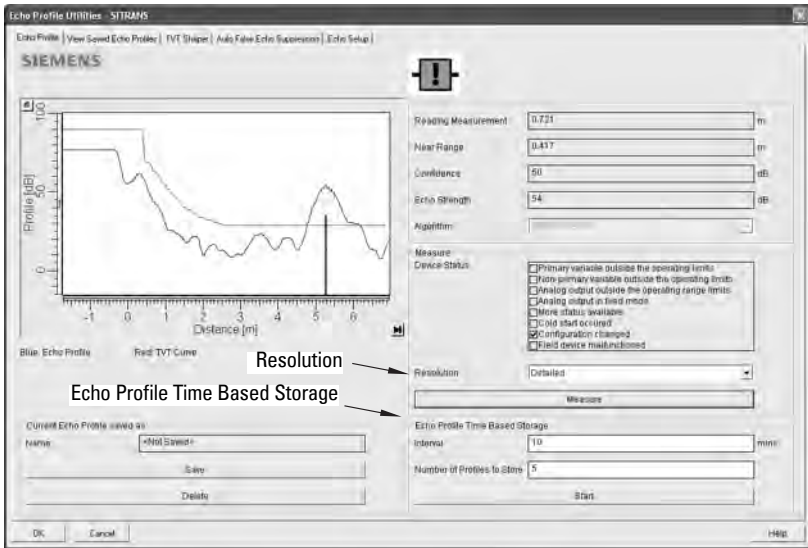

Echo profile data logging

You can store up to 60 profiles at a selected interval (maximum 60 minutes). Inside Echo Profile Utilities, in the **Echo Profile Time Based Storage** window:

- Enter the desired interval between stored profiles.
- Enter the desired number of profiles to be stored (maximum 60).
- Click on **Start**. A message appears warning of the time delay and warning that all previous saved profiles will be overwritten. Click on **OK** to proceed. The new profiles will be saved with their date and time.
- Click on the tab **View Saved Echo Profiles** to view the stored profiles

TVT Shaper

Note: Double click on each axis to see the Xscale and Data Scale values. Right-click or Left-click on the axis and drag to reposition the scale.

This feature allows you to manually adjust the TVT to avoid false echoes caused by obstructions. (For an explanation see *Auto False Echo Suppression (2.8.7.1)* on page 128.)

Open the menu **Device – Echo Profile Utilities** and click on the tab **TVT Shaper**

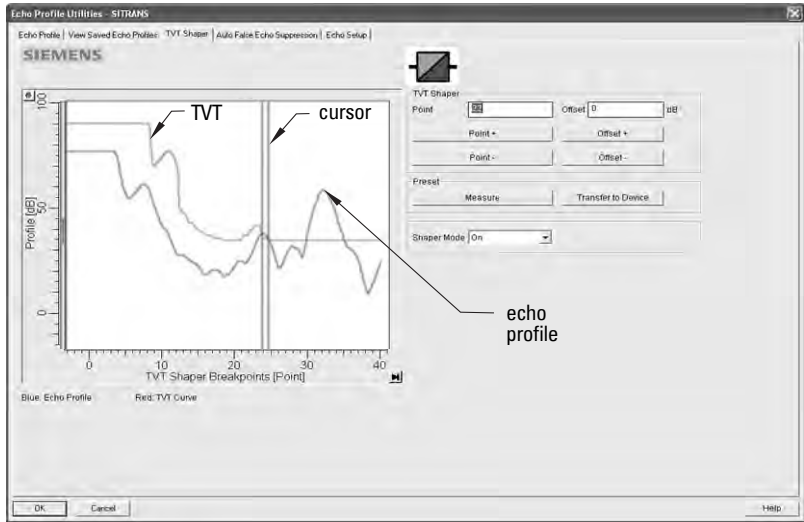

- Click on **Measure** to refresh the echo profile and load the current TVT from the device.
- Change the position of the cursor on the TVT using the **Point+** and **Point-** buttons: raise and lower the TVT using **Offset+** and **Offset-**.
- Alternatively, enter values for **Point** and **Offset** directly into the dialog boxes.
- Click on **Transfer to Device**.

Auto False Echo Suppression

Notes:

- Make sure material level is below all known obstructions at the moment Auto False Echo Suppression is used to learn the echo profile. We recommend an empty or almost empty vessel.
- Note the distance to material level when the environment is learned, and set Auto False Echo Suppression Range to a shorter distance to avoid the material echo being screened out.
- Set Auto False Echo Suppression and Auto False Echo Suppression Range during startup, if possible.
- If the vessel contains an agitator it should be running.
- Before adjusting these parameters, rotate the instrument for best signal (lower false-echo amplitude).

If you have a vessel with known obstructions, we recommend using Auto False Echo Suppression to prevent false echo detection. This feature can also be used if the device displays a false high level, or the reading is fluctuating between the correct level and a false high level.

The device learns the echo profile over the whole measurement range and the TVT is shaped around all echoes present at that moment. (See *Auto False Echo Suppression (2.8.7.1.)* on page 128 for a more detailed explanation.)

The learned TVT will be applied over a specified range. The default TVT is applied over the remainder of the measurement range.

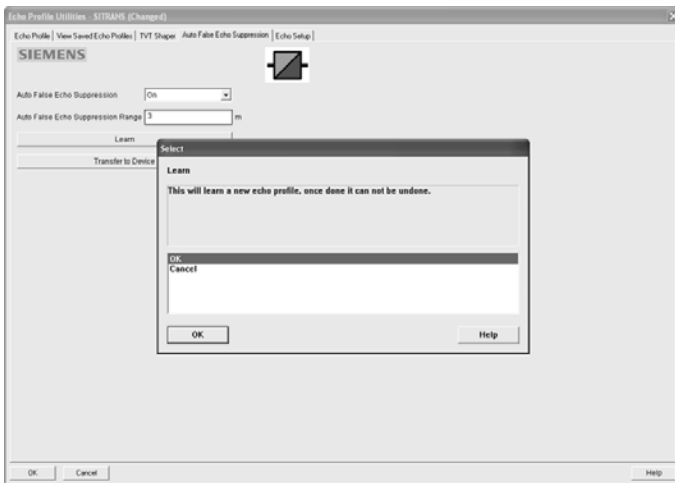

- 1) Make sure the material level is below all known obstructions.
- 2) Determine **Auto False Echo Suppression Range**. Measure the actual distance from the sensor reference point to the material surface using a rope or tape measure. Subtract 0.5 m (20") from this distance, and use the resulting value.

- 3) Open the menu **Device – Echo Profile Utilities** and click on the tab **Auto False Echo Suppression**.
- 4) Enter the value for **Auto False Echo Suppression Range** and select **On**.
- 5) Click on **Learn**. The message appears: **'This will learn a new echo profile. Once done it cannot be undone'**. Click on **OK**.
- 6) Once Auto TVT is complete click on **Transfer to Device**. To exit click on **OK**. Auto TVT is enabled and the learned TVT will be used.
- 7) To turn Auto False Echo Suppression off or on, reopen the **Auto False Echo Suppression** window and click on **Off** or **On**.

Before Auto False Echo Suppression

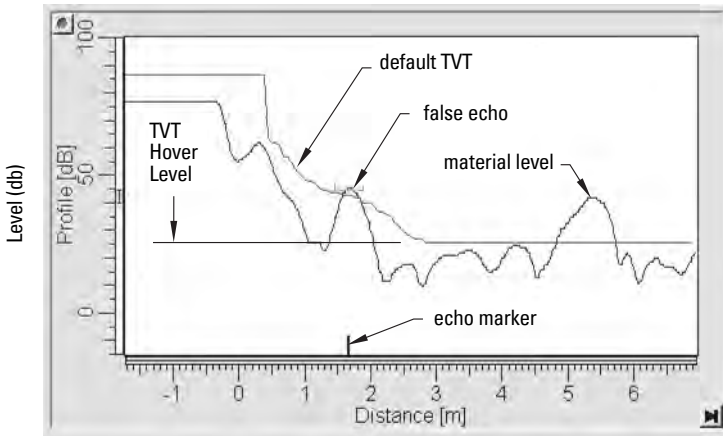

After Auto False Echo Suppression

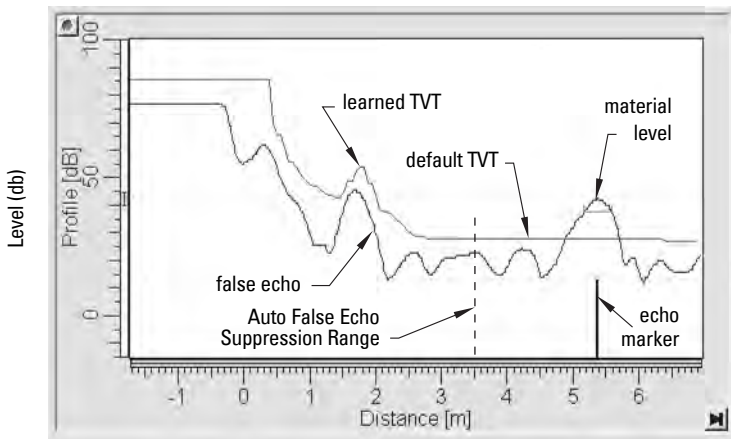

Echo Setup

Provides quick access to echo profile parameters:

- Algorithm
- Position Detect
- Echo Threshold
- Damping Filter
- CLEF Range
- Response Rate
- Fill Rate/min.
- Empty Rate/min.



Open the menu **Device – Echo Profile Utilities** and click on **Echo Setup**.

Maintenance

You can set schedules and reminders for:

- device maintenance based on its projected lifetime
- sensor maintenance based on its projected lifetime
- service
- calibration

To set Device/Sensor Maintenance schedules:



- 1) Open the menu **Device – Maintenance**, and click on the **Remaining Device/Sensor Lifetime** tab.

- 2) Modify desired values, and click on **Write**.
- 3) Click on **Read**, to see the effects of your modification.
- 4) If desired, set reminders for either or both of **Reminder 1 (Required)/Reminder 2 (Demanded)**.
- 5) Click on **Snooze** to add a year to the Total Expected Device Life.

To set Service/Calibration schedules:

- 1) Open the menu **Device – Maintenance**, and click on the **Service/Calibration Schedule** tab.
- 2) Modify desired values, and click on **Write**.
- 3) Click on **Read**, to see the effects of your modification.
- 4) If desired, set reminders for either or both of **Reminder 1 (Required)/Reminder 2 (Demanded)**.
- 5) Click on **Service/Calibration Performed** to reset the schedule.

Select Analog Output

Allows you to set the mA Output to report Level, Distance, or Space (see Current Output Function (2.6.1.) on page 81 for an illustration).

If a volume application is selected, mA Output is automatically set to Volume. (See Analog Output on page 130 for more details.)

- 1) Open the menu **Device – Select Analog Output**.
- 2) The **Select Analog Output** window displays the current setting: click on **OK**.
- 3) Select a different setting and click on **OK**.
- 4) The **Select Analog Output** window displays the new setting: click on **OK**.

Self Test

Checks memory (RAM and Flash). If there are no errors, returns the message 'Self Test OK.' If errors are found, returns the message 'Self Test Fails.'

Open the menu **Device – Self Test**, select the option **Yes** and click on **OK**.

Loop-Test

Note: The simulated AO (Analog Output) value influences output to the control system.

*Allows you to input a simulated value (4 mA, 20 mA, or a user-defined value) in order to test the functioning of the mA connections during commissioning or maintenance of the device. (The range is 3.56 mA: see **mA Output Value (2.6.6.)** on page 83).*

To simulate a user-defined mA value:

- 1) Open the menu **Device – Loop-Test**.
- 2) Select **Other**, enter the new value, and click on **OK**. The message 'Field Device fixed at [new value]' appears. Click on **OK**. The Loop-Test window remains open.
- 3) When you are ready to end simulation, select **End** and click on **OK** to return the device to the actual output value.

Configuration Flag Reset

To reset the configuration flag to zero, open the menu **Device – Configuration Flag Reset** and perform a reset.

Master Reset

Factory Defaults

Use **Factory Defaults** to reset all user parameters to the default settings, with certain exceptions. The list of exceptions includes, but is not limited to, Tag, Message, Description, Installation Data, Device Address, Write Protect and PIN to Unlock. Auto False Echo Suppression Range and the learned TVT also remain unchanged.

- 1) Open the menu **Device – Master Reset** and click on **OK** to perform a reset to Factory Defaults.
- 2) After the reset is complete upload parameters to the PC/PG. (If you are performing a reset after replacing the device with a different instrument, do not upload parameters to the PC/PG).

Wear

Reports the number of hours the device has been operating, and the number of times it has been powered up.

Open the menu **Device – Wear** to view:

- Powered Days
- Power-on Resets

HART Communication

Allows you to set the number of request/response preambles (minimum 5).

Open the menu **Device – HART Communication**.

Diagnostics

You can monitor level/volume trends, electronics temperature, and device status.

Process Variables

To compare outputs in real time open the menu **View – Process Variables** and click on **Overview** to see reading (level, space, distance, volume); analog output; device status; and current electronics temperature.

To see highest and lowest electronics temperatures, navigate to **Level Meter > Maintenance and Diagnostics > Electronics Temperature**.

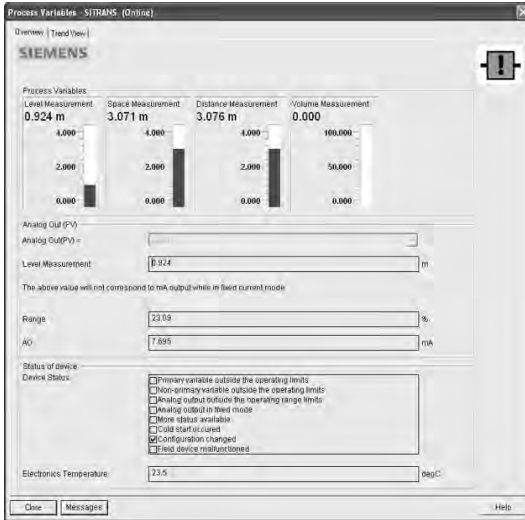

Trend

Open the menu **View – Process Variables** and click on **Trend**.

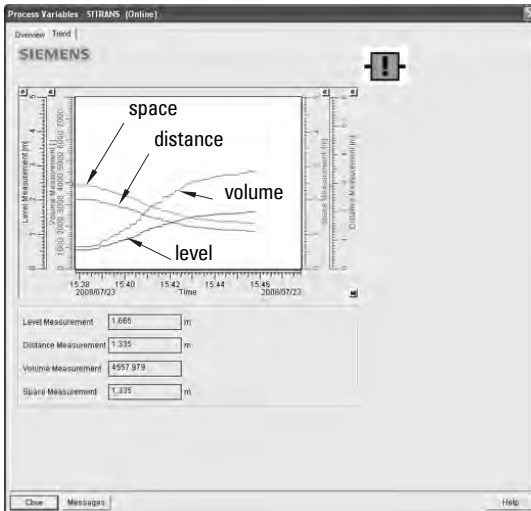

4 trend lines can be monitored: (distinguished by color in SIMATIC PDM).

Device Status

Open the menu **View – Device Status** to view Diagnostics, Device Status, Hardware/ Firmware (HW/FW) Status, and Maintenance status.

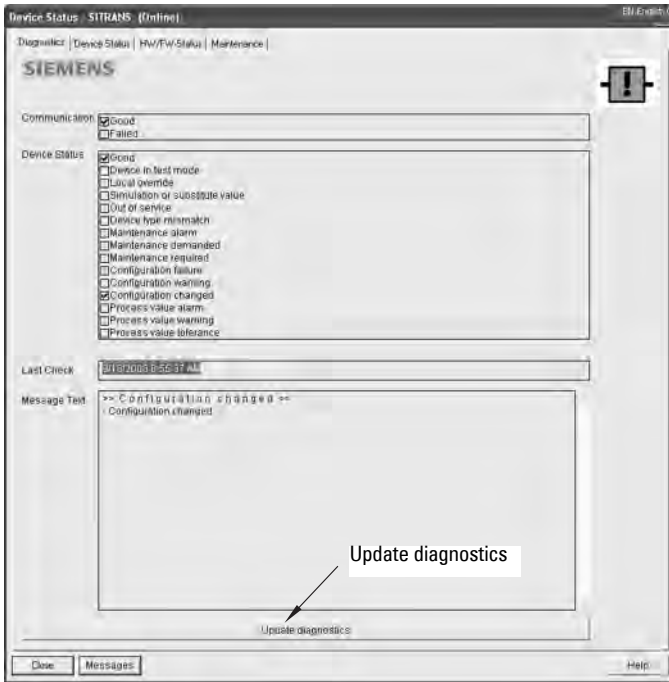

In the Diagnostics window, click on **Update diagnostics** to update diagnostic information and refresh linked icons.

Update

Open the menu **View – Update** to refresh the screen.

Security

A password option protects security and communication control parameters from modification by a maintenance user.

When you open a project the **User** dialog window provides two options: maintenance or specialist. If a password has been set it will not be possible to open the project as a specialist without it. A maintenance user will be able to open the project without a password but will not have access to security and communication control parameters.

- 1) Open a project, double-click on the device icon, and in the **User** window select **Specialist**.
- 2) Open the menu **Options – Settings** and click on the **Password** tab.
- 3) Enter a new password and re-enter it in the **Confirmation** window. Click on **OK**.

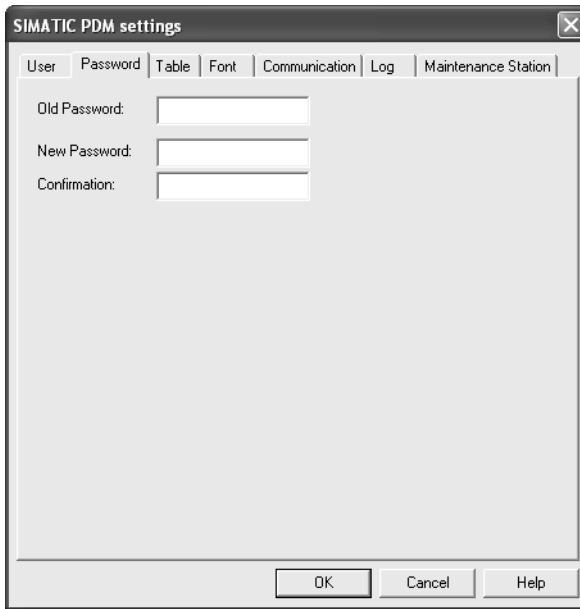

Operating via AMS Device Manager

AMS Device Manager is a software package used to commission and maintain SITRANS LR200 and other process devices. Please consult the operating instructions or online help for details on using AMS Device Manager. (You can find more information at <http://www.emersonprocess.com/AMS/>.) Application Guides for setting up Siemens HART devices with AMS Device Manager are available on our website at: www.siemens.com/processautomation.

Functions in AMS Device Manager

Note: While the device is in PROGRAM mode the output remains fixed and does not respond to changes in the device.

AMS Device Manager monitors the process values, alarms and status signals of the device. It allows you to display, compare, adjust, verify, and simulate process device data

Parameters organized into three main function groups allow you to configure and monitor the device:

- Configure/Setup
- Device Diagnostics (read only)
- Process Variables (read only)

See *AMS Menu Structure* on page 69 for a chart¹⁾ and *Changing parameter settings using AMS Device Manager* on page 61 for more details.

Features of AMS Device Manager

The graphic interface in SITRANS LR200 makes monitoring and adjustments easy.

Feature	page	Function
Quick Start	59	Device configuration for simple applications
Echo Profile	65	Echo profile viewing
TVT	64	(Auto False Echo Suppression) – screen out false echoes
Linearization	60	Volume measurement in an irregular vessel
Process Variables	67	Monitor process variables and level trend
Security	66	Protect security and communication parameters from modification by the maintenance user

¹⁾ The menu structure for AMS Device Manager is almost identical to that for the LCD.

Device Description (DD)

SITRANS LR200 requires the DD for AMS Device Manager version 9.0.

You can locate the DD in Device Catalog, under **Sensors/Level/Echo/Siemens Milltronics/SITRANS LR200**. Check the product page of our website at: www.siemens.com/LR200, under **Downloads**, to make sure you have the latest version of AMS Device Manager. If you need to install a new DD see *Configuring a new device* below.

Configuring a new device

- 1) Check that you have the most recent DD, and if necessary download it from the product page listed above. Save the files to your computer, and extract the zipped file to an easily accessed location.
- 2) Launch **AMS Device Manager– Add Device Type**, browse to the unzipped DD file and select it.

Startup

- 1) **Launch AMS Device Manager**. (Application Guides for setting up HART devices with AMS Device Manager can be downloaded from the product page of our website at www.siemens.com/LR200.)
- 2) In **Device Connection View** right-click on the device icon and select **Scan Device** to upload parameters from the device.
- 3) Double click the device icon to open the startup screen. The startup screen shows device identification details, and a navigation window on the left-hand side of the screen.

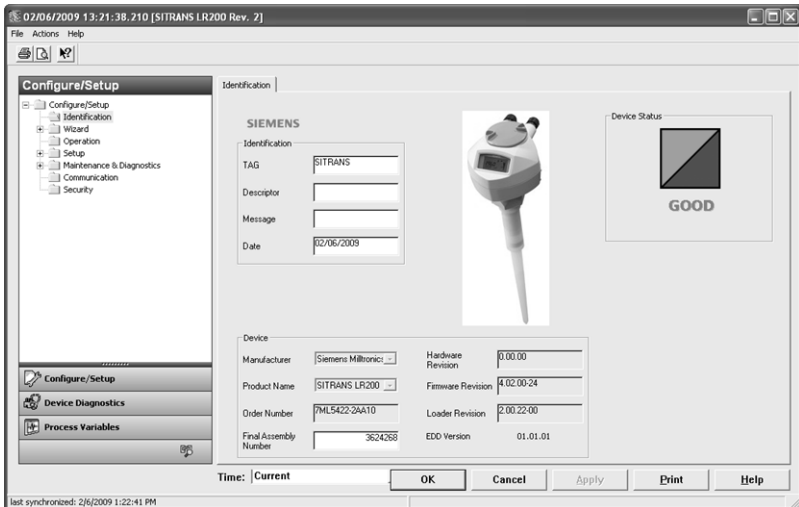

Master Reset

- Navigate to **Configure/Setup > Operation**
- In the **General** field click on **Master Reset** and accept the option **Factory Defaults**.

Pull-down menu access

Action menu items



A pull-down menu under **Actions** gives alternative access to several features.

Scan Device

- Open the menu **Actions – Scan Device**.
- **Scan Device** uploads parameters from the device (synchronizes parameters).

Device configuration

- 1) Navigate to **Configure/Setup > Operation** and click to open the dialog window.

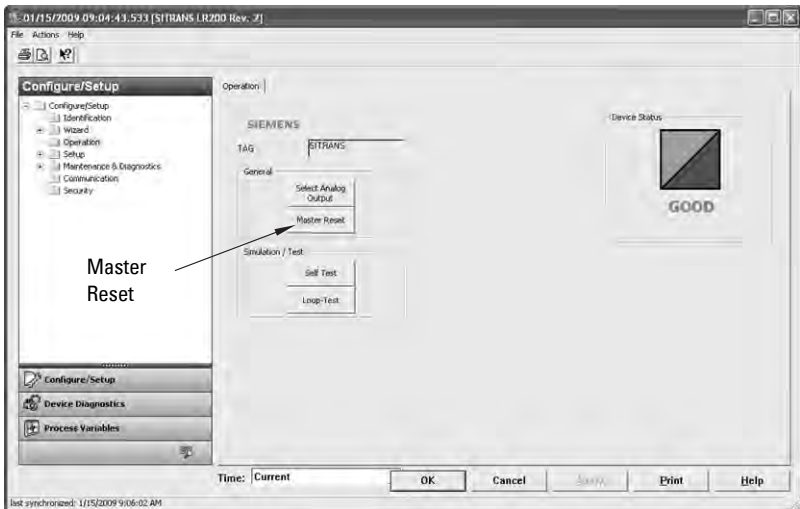

- 2) In the **General** field, click on **Master Reset**. and perform a reset to Factory Defaults.
- 3) Open the pull-down menu **Actions – Scan Device** to synchronize parameters (upload parameters from the device to AMS).
- 4) Configure the device via the Quick Start wizard.

Quick Start Wizard via AMS Device Manager

Notes:

- The layout of the dialog boxes shown may vary according to the resolution setting for your computer monitor
- At each step, you can accept the default values without modification and click on the next step to proceed.
- After modifying parameters click on **Apply** inside the Quick Start window to write the new values to the device.
- Click on **OK** only if you wish to update all parameters to the device and close AMS.

A Wizard provides an easy 5-step Quick Start procedure that configures the device for a simple application.

Quick Start

Step 1 – Identification

- 1) Navigate to **Configure/Setup > Wizard > Quick Start**.
- 2) Click on **Step 1**.
- 3) You can accept the default values without modification. (Description, Message, and Installation Date fields can be left blank.) If desired, make changes then click on **Apply**.

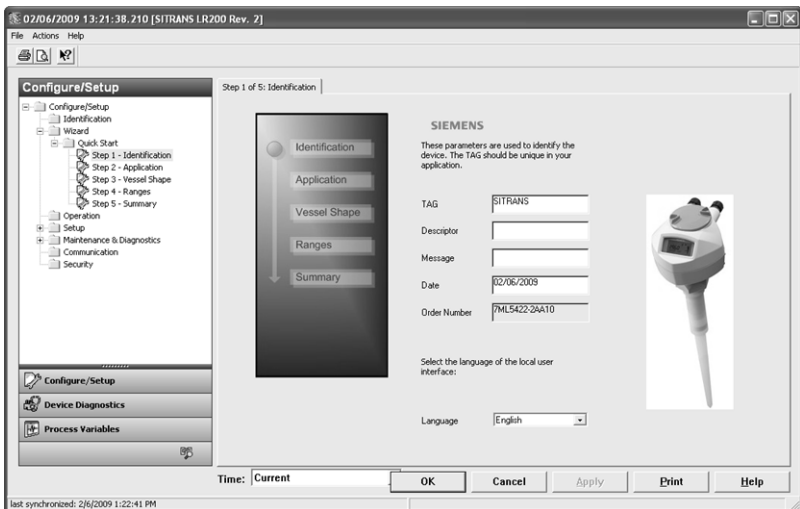

Step 2 – Application Type

- 1) Click on **Step 2**.
- 2) Select the application type (Level, Space, Distance, or No Service¹⁾) and the material (Liquid or Low dielectric liquid).
- 3) Click on **Apply**.

¹⁾ For details see *Sensor Mode* on page 131.

Step 3 – Vessel Shape

- 1) Click on **Step 3**.
- 2) Select a predefined vessel shape. (To describe a more complex shape see *Linearization* below.)
- 3) Click on **Apply**.

Step 4 – Range

- 1) Click on **Step 4**.
- 2) Change units if desired (in meters by default).
- 3) Set High and Low Calibration points.
- 4) To convert the reading from level to volume enter a value for Maximum Volume.
- 5) If a vessel shape with parabolic ends has been selected, set dimensions **A** and **L**.
- 6) Click on **Apply**.

Step 5 – Summary

Check parameter settings, and click on **Cancel** to abort, or **Apply** to transfer values to the device.

Linearization

You can use the linearization feature to define a more complex vessel shape and enter up to 32 level breakpoints where the corresponding volume is known. The values corresponding to 100% and 0% levels must be entered. The breakpoints can be ordered from top to bottom, or the reverse. (See *Linearization* on page 41 for an example.)

Using Linearization via the Quick Start wizard

- 1) Navigate to **Configure/Setup > Wizard > Quick Start**.
- 2) In **Step 1 – Identification** make any desired modifications and click on **Apply**.
- 3) In **Step 2 – Application Type** select a level application and liquid as a material.
- 4) In **Step 3 – Vessel Shape**, choose the vessel shape option **Linearization Table**.
- 5) In **Step 4 – Range Setup** enter a value for maximum volume.

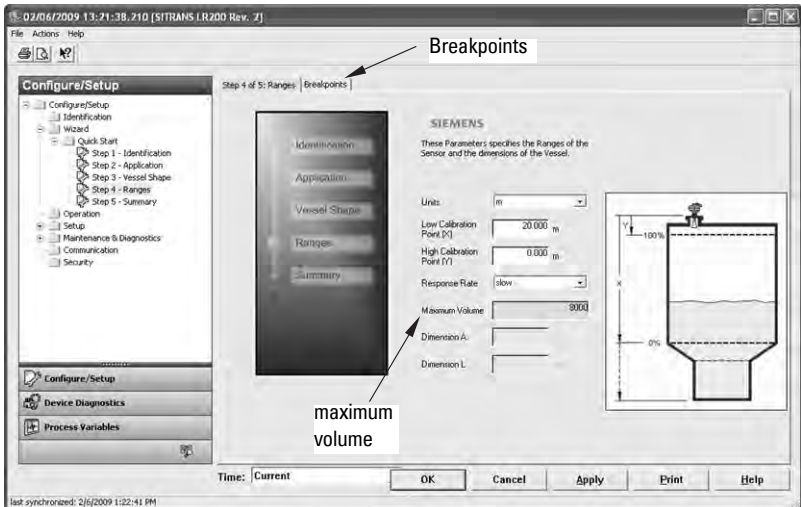

- 6) Click on the **Breakpoints** tab and enter values for level and volume for up to 32 breakpoints.
- 7) Navigate to **Configure/Setup > Setup > Linearization** and click on **Characteristic** to preview the characteristic curve of the vessel breakpoints.
- 8) In **Step 5 – Summary** check parameter values. Click on the appropriate step menu to return and revise values, or click on a different menu to exit **Quick Start**.

Changing parameter settings using AMS Device Manager

Notes:

- For a complete list of parameters, see *Parameter Reference* on page 75.
- For more detailed explanations of the parameters listed below see the pages referenced.

- 1) Adjust parameter values in the parameter value field in Configure/Setup view, then click on **Apply** to write the new values to the device. The parameter field will display in yellow until the value has been written to the device.
- 2) Click on **OK** only if you wish to update all parameters and exit AMS.

Operation

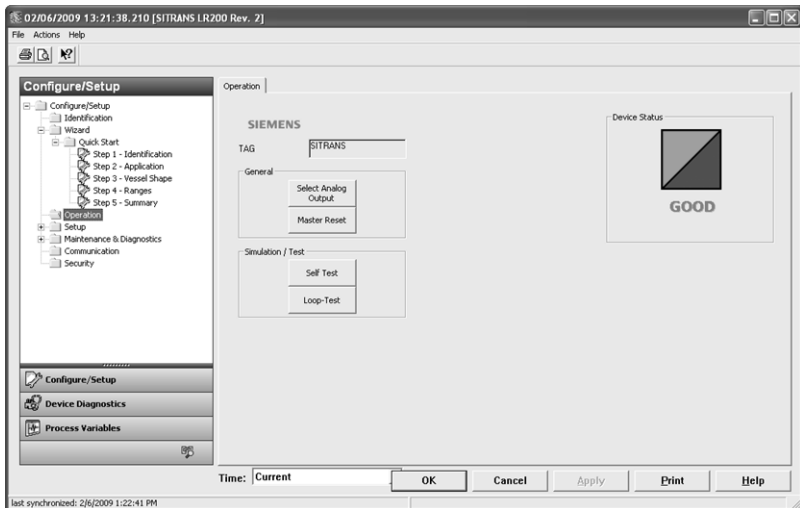

Navigate to **Configure/Setup > Operation** and click on **Operation** to open the dialog window for access to:

General:

- Select Analog Output (see *Select Analog Output* on page 51)
- Master Reset (see *Master Reset* on page 52)

Simulation/Test

- Self Test (see *Self Test* on page 51)
- Loop Test (see *Loop-Test* on page 52)

Setup

Note: For more detailed explanations of the parameters listed below see the pages referenced.

Sensor

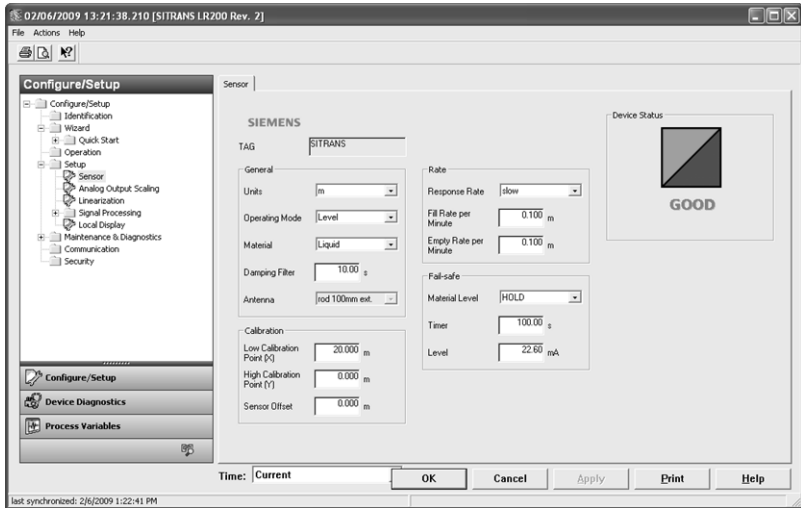

Navigate to **Configure/Setup > Setup** and click on **Sensor** for access to:

General [see Sensor (2.2.) on page 76]

- Units
- Operating Mode
- Material
- Damping Filter
- Antenna (read only)

Calibration [see Calibration (2.3.) on page 77]

- Low Calibration Point
- High Calibration Point
- Sensor Offset

Rate [see Rate (2.4.) on page 78]

- Response Rate
- Fill rate/minute
- Empty rate/minute

Fail-safe [see Fail-safe (2.5.) on page 80]

- Material level
- Timer
- Level

Analog Output Scaling

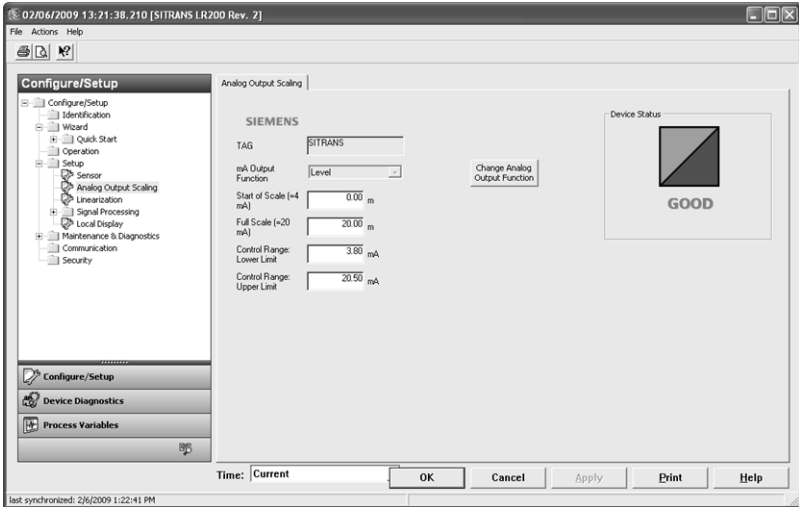

Navigate to **Configure/Setup > Setup** and click on **Analog Output Scaling** for access to:

Analog Output Scaling [see Analog Output Scaling (2.6.) on page 81]

- mA Output Function
- Start of scale
- Full Scale
- Control Range (lower limit)
- Control Range (upper limit)

Signal Processing

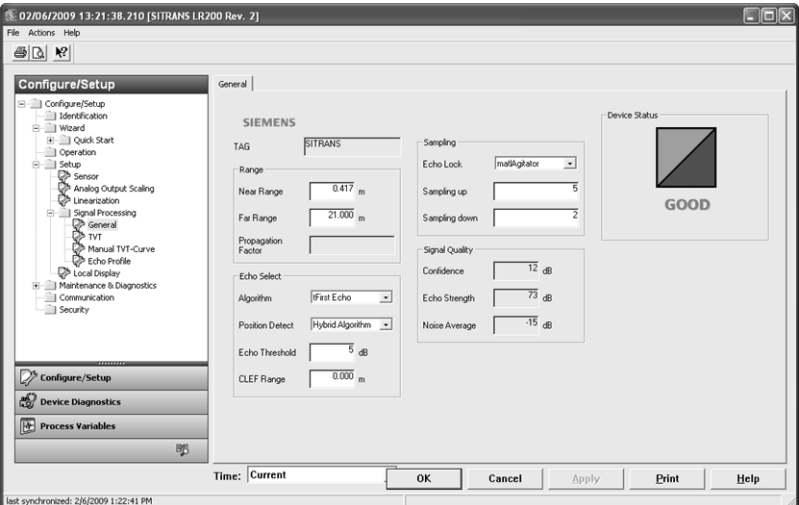

Signal Processing (continued)

General

Navigate to **Configure/Setup > Setup > Signal Processing** and click on **General** for access to:

Range [see Signal Processing (2.8.) on page 87]

- Near Range
- Far Range
- Propagation Factor

Echo Select [see Echo select (2.8.4.) on page 88]

- Algorithm
- Position Detect
- Echo Threshold
- CLEF Range

Sampling [see Sampling (2.8.5.) on page 90]

- Echo Lock
- Sampling Up
- Sampling Down
- Echo Lock Window

Signal Quality

- Confidence
- Echo Strength
- Noise Average
- Noise Peak

TVT

Modify the TVT to screen out false echoes [see *Auto False Echo Suppression (2.8.7.1.)* on page 128].

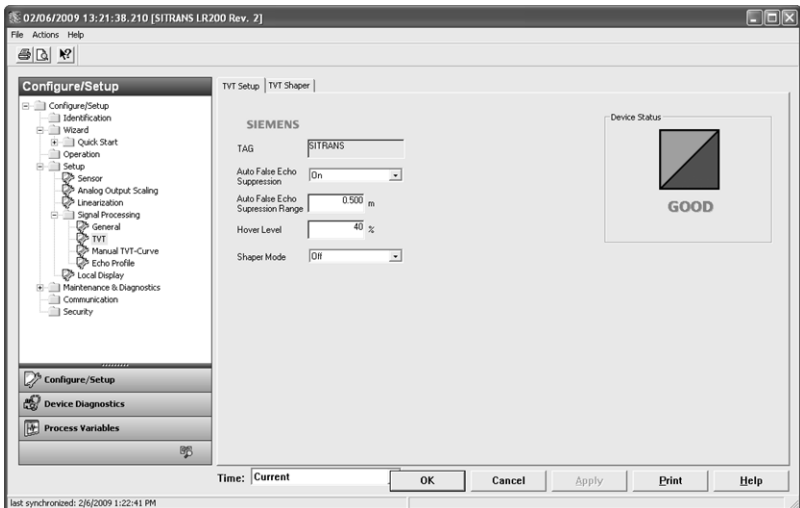

Navigate to **Configure/Setup > Setup > Signal Processing** and click on **TVT**. Click on one of the two tabs to access the parameters listed.

TVT Setup [see Auto False Echo Suppression (2.8.7.1.) on page 92]

- Auto False Echo Suppression Range
- Auto False Echo Suppression
- Hover Level
- Shaper Mode

TVT Shaper

- Shaper breakpoints 1 to 40. (Turn **TVT Setup/Shaper Mode** on to activate.)

Manual TVT Curve

Displays the effects of the TVT shaper modifications. Navigate to **Configure/Setup > Setup > Signal Processing** and click on **Manual TVT Curve**.

Echo Profile

- Navigate to **Configure/Setup > Setup > Signal Processing** and click on **Echo Profile**.
- Select **Standard** operation for faster display.

Local Display

Navigate to **Configure/Setup > Setup > Local Display** for access to:

- Language
- LCD Fast Mode [see **LCD Fast Mode (4.9.)** on page 110]
- LCD Contrast [see **LCD Contrast (4.10.)** on page 110]

Maintenance and Diagnostics

Navigate to **Maintenance and Diagnostics** for access to:

Remaining Device Lifetime [see Remaining Device Lifetime (4.2.) on page 97]

- Lifetime expected
- Remaining Lifetime
- Time in Operation
- Activation of Reminders
- Reminder 1 before Lifetime (Required)
- Reminder 2 before Lifetime (Demanded)

Remaining Sensor Lifetime [see Remaining Sensor Lifetime (4.3.) on page 100]

- Lifetime expected
- Remaining Lifetime
- Time in Operation
- Activation of Reminders
- Reminder 1 before Lifetime (Required)
- Reminder 2 before Lifetime (Demanded)

Service Schedule [see Service Schedule (4.4.) on page 103]

- Service Interval
- Time since last Service
- Time until next Service
- Activation of Reminders
- Reminder 1 before Service (Required)
- Reminder 2 before Service (Demanded)

Calibration Schedule [see Calibration Schedule (4.5.) on page 106]

- Calibration Interval
- Time since last Calibration
- Total Until Next Calibration
- Activation of Reminders
- Reminder 1 before Calibration (Required)
- Reminder 2 before Calibration (Demanded)

Electronic Temperature

- Electronic Temperature
- Lowest Value
- Highest Value

Wear (see *Wear* on page 52)

- Powered days
- Poweron Resets

Communication

Navigate to **Communication** to read the following:

Tag; Manufacturer's ID; Device ID; Product ID; Device Revision; EDD Revision; Universal Command

Security

Navigate to **Configure/Setup > Security** to access:

Remote Access [see Remote Access (6.1.) on page 111]

Note: If access control is changed to limit remote access, it can only be reset via the handheld programmer. See **Access Control (6.1.1.)** on page 111.

- Write Protect (read only)
- Access Control

Local Access [see Local Access (6.2.) on page 112]

- Local Write Protected
- PIN to Unlock

See also *Password Protection* on page 68.

Device Diagnostics

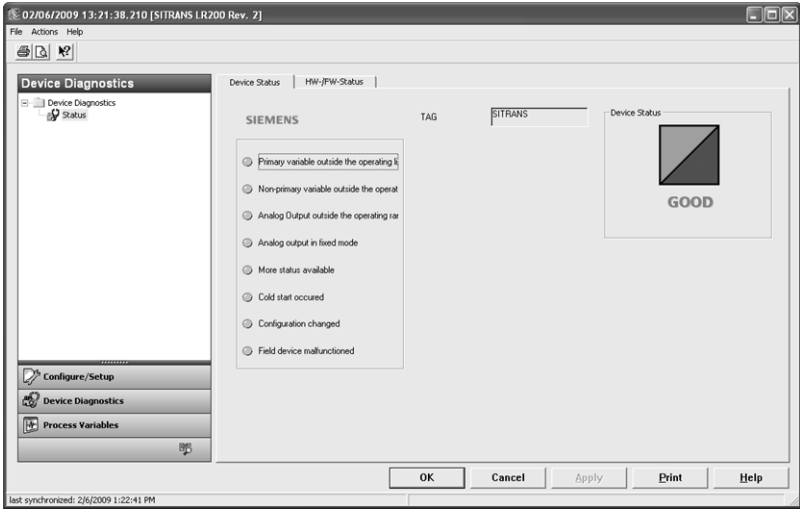

Click on the **Device Diagnostics** bar at the bottom of the navigation window, for access to:

- Device Status
- Hardware/Firmware Status

Process Variables

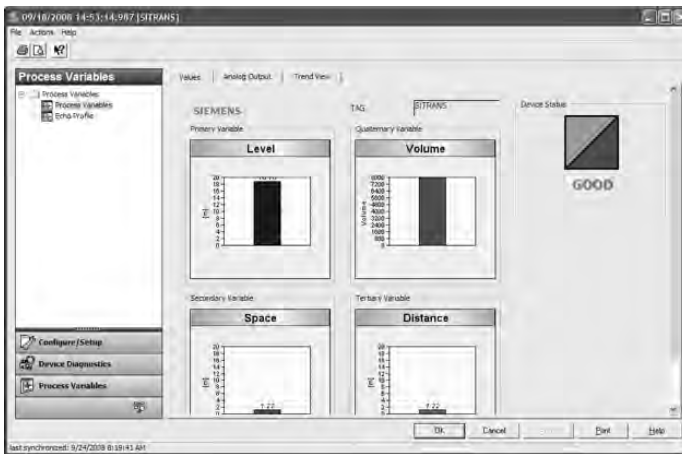

To compare outputs in real time click on the **Process Variables** bar at the bottom of the navigation window for access to:

Process Variable

- Values (level, volume, distance, space)
- Analog output
- Trend View

Echo Profile (also accessible via Signal Processing)

Password Protection

An AMS Device Manager administrator can configure the user to require a password. The use of passwords is recommended. A password should be assigned to the 'admin' username immediately after installing AMS Device Manager.

Each user is given an AMS Device Manager username and password and required to enter them when they start AMS Device Manager. Access to functions depends on the level of permissions granted.

Login types

- standard, local, or domain

A standard user can change their password in AMS Device Manager. A Local or Domain Windows user cannot change their password using AMS Device Manager and must request their network administrator to do so.

User Manager utility

Username, passwords, and permissions, are assigned to users by an AMS Device Manager administrator, using the User Manager utility on the Server Plus Station. Only a user with AMS Device Manager System Administration rights can log in to User Manager.

To configure a new user/edit existing user:

- 1) From the Windows taskbar select: **Start > AMS Device Manager > User Manager.**
- 2) In the User Manager window click on **Add User.**

The Add User Wizard dialog allows you to:

- select a user type, standard (AMS Device Manager) or Window user.
- enter the username and password, and set permissions
- edit existing users

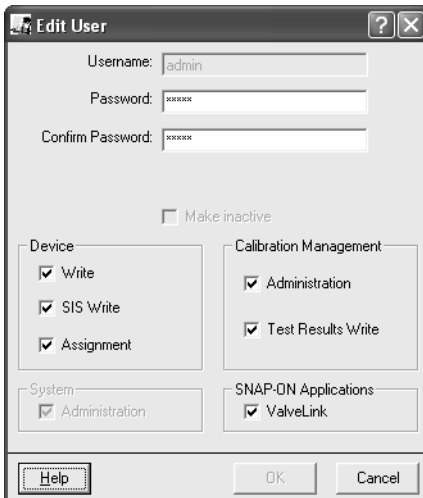

AMS Menu Structure

Configure/Setup

Identification

Identification

- Tag
- Description
- Message
- Date

Device

- Manufacturer
- Product Name
- Order Number
- Final Assembly Number
- Hardware Revision
- Firmware Revision
- Loader Revision
- EDD number

Wizard

Quick Start

- Step 1 (Identification)
- Step 2 (Application Type)
- Step 3 (Vessel Shape)
- Step 4 (Range)
- Step 5 (Summary)

Operation

General

- Select Analog Output
- Master Reset

Simulation/Test

- Self Test
- Loop-Test

Setup

Sensor

- General
 - Units
 - Operating Mode
 - Material
 - Damping Filter
 - Antenna

Configure/Setup (continued)

Setup/Sensor (continued)

Calibration

- Low Calibration Point
- High Calibration Point
- Sensor Offset

Rate

- Response Rate
- Fill rate/minute
- Empty rate/minute

Fail-safe

- Timer
- Material Level
- Level

Analog Output Scaling

- Analog Output Scaling
- mA Output Function
- Start of Scale
- Full Scale
- Control Range lower limit
- Control Range upper limit

Linearization

- Linearization
 - Vessel Shape
 - Vessel dimensions
 - Max. volume
 - Dimension A
 - Dimension L

Characteristic

Signal Processing

General

Range

- Near Range
- Far Range
- Propagation Factor

Echo Select

- Algorithm
- Position Detect
- Echo Threshold
- CLEF Range

Sampling

- Echo Lock
- Sampling Up
- Sampling Down
- Echo Lock Window.

Configure/Setup (continued)

Setup/Signal Processing (continued)

Signal Quality

Confidence

Echo Strength

Noise average

Noise Peak

TVT

TVT Setup

Auto False Echo Suppression Range

Auto False Echo Suppression

Hover Level

Shaper Mode

TVT Shaper

Manual TVT Curve

Echo Profile

Local Display

Maintenance and Diagnostics

Remaining Device Lifetime

Lifetime expected

Remaining Lifetime

Time in Operation

Activation of Reminders

Reminder 1 before Lifetime (Required)

Reminder 2 before Lifetime (Demanded)

Remaining Sensor Lifetime

Lifetime expected

Remaining Lifetime

Time in Operation

Activation of Reminders

Reminder 1 before Lifetime (Required)

Reminder 2 before Lifetime (Demanded)

Maintenance and Diagnostics (continued)

Service Schedule

Service Interval

Time since last Service

Total Service Interval minus Time Since Last Service

Activation of Reminders

Reminder 1 before Service (Required)

Reminder 2 before Service (Demanded)

Calibration Schedule

Calibration Interval

Time since last Calibration

Total Until Next Calibration

Activation of Reminders

Reminder 1 before Calibration (Required)

Reminder 2 before Calibration (Demanded)

Electronic Temperature

Electronic Temperature

Lowest Value

Highest Value

Wear

Powered days

Poweron Resets

Communication

Security

Remote Access

Write Protect

Access Control

Local Access

Local Write Protected

PIN to Unlock

Operating via FDT (Field Device Tool)

FDT is a standard used in several software packages designed to commission and maintain field devices such as SITRANS LR200. Two commercially available FDTs are PACTware and Fieldcare.

Functionally FDT is very similar to PDM (see *Operating via SIMATIC PDM* on page 35 for more detail).

- To configure a field device via FDT you need the DTM (Device Type Manager) for the device.
- To configure a field device via SIMATIC PDM, you need the EDD (Electronic Data Description) for the device.

Device Type Manager (DTM)

A DTM is a type of software that 'plugs into' FDT. It contains the same information as an EDD but an EDD is independent of the operating system.

SITRANS DTM

- SITRANS DTM is an EDDL interpreter developed by Siemens to interpret the EDD for that device.
- To use SITRANS DTM to connect to an instrument, you must first install SITRANS DTM on your system and then install the instrument EDD written for SITRANS DTM.
- You can download SITRANS DTM from the Siemens service and support website. Go to <http://support.automation.siemens.com>, click on **Product Support**, and drill down to **Product Information/Automation Technology/Sensor systems/Process Instrumentation/Software & Communications**.

The instrument EDD

The SITRANS LR200 HART EDD for SITRANS DTM can be downloaded from the product page of our website at www.siemens.com/LR200. Go to **Support > Software Downloads**.

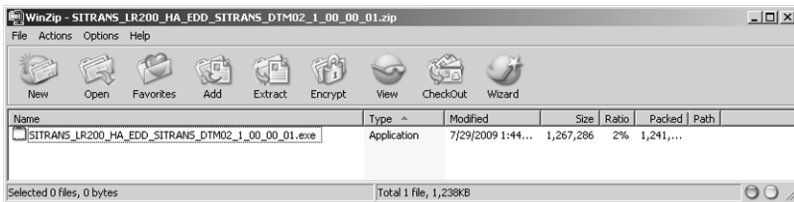



Configuring a new device via FDT

The full process to configure a field device via FDT is outlined in an application guide which can be downloaded from the product page of our website. Go to: www.siemens.com/LR200 under **Support**.

Note

Parameter Reference

Notes:

- Parameter names and menu structure are almost identical for SIMATIC PDM and the local user interface (LUI)¹⁾.
- Default settings in the parameter tables are indicated with an asterisk (*) unless explicitly stated.
- **Mode**  toggles between **PROGRAM** and **Measurement** Modes.
- For Quick Access to parameters via the handheld programmer, press **Home** , then enter the menu number, for example: **2.2.1**.



- In Navigation mode, **ARROW keys** navigate the menu in the direction of the arrow.
- Press **RIGHT arrow** to open **Edit Mode**, or to save a modification.

Parameters are identified by name and organized into function groups. See *LCD menu structure* on page 179 for a chart¹⁾.

Parameters accessible via the handheld programmer are preceded by a number.

Parameters not preceded by a number are accessible only via remote operation. For more details see:

- *Operating via SIMATIC PDM* on page 35
- *Operating via AMS Device Manager* on page 56

Quick Start Wizard

The Quick Start wizard provides an easy step-by-step procedure to configure the device for a simple application.

1. Quick Start

Notes:

- Do not use the Quick Start wizard to modify individual parameters. (Perform customization only after the Quick Start has been completed.)
- For access via remote operation see *Quick Start Wizard via SIMATIC PDM* on page 37 or *Quick Start Wizard via AMS Device Manager* on page 59 .
- For detailed instructions see *Quick Start Wizard via the handheld programmer* on page 31 .

1.1. Language

1.2. Material

1.3. Response Rate

1.4. Units

¹⁾ For AMS Device Manager and DTM Device Manager the structure varies slightly.

- 1.5. Operating Mode
- 1.6. Low Calibration Point
- 1.7. High Calibration Point
- 1.8. Apply? (Apply changes)

2. Setup

Note: Default settings in the parameter tables are indicated with an asterisk (*) unless explicitly stated.

2.1. Device

2.1.1. Hardware Revision

Corresponds to the electronics hardware of the SITRANS LR200.

2.1.2. Firmware Revision

Corresponds to the firmware that is embedded in the SITRANS LR200.

2.1.3. Loader Revision

Corresponds to the software used to update the SITRANS LR200.

2.1.4. Order Option

Read only. Displays the device type: standard or NAMUR NE 43-compliant.

2.2. Sensor

2.2.1. Units

Sensor measurement units.

Values	m, cm, mm, ft, in
	Default: m

2.2.2. Sensor Mode

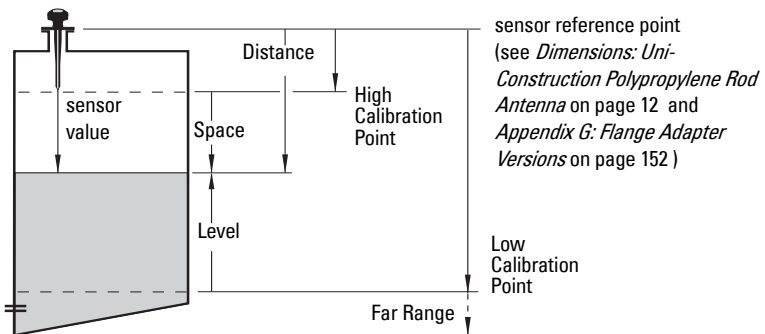

Mode	Description	Reference point
NO SERVICE	Measurement and associated loop current are not updated, and the device defaults to Fail-safe mode ^{a)} .	n/a
LEVEL	*	Low Calibration Point (process empty level)
SPACE	Distance to material surface	High Calibration Point (process full level)
DISTANCE		Sensor Reference Point

^{a)} See **Material Level (2.5.1.)** for more detail.

2.2.3. Material

Automatically configures the device to operate in the chosen application type, by changing one or more of the following parameters: **Propagation Factor (2.8.3.)**, **Position Detect (2.8.4.2.)**, and/or **CLEF Range (2.8.4.4.)**.

Options	*	LIQUID
		LIQUID LOW DK ^{a)} (low dielectric liquid – CLEF algorithm enabled)
Related parameters	Propagation Factor (2.8.3.) Position Detect (2.8.4.2.) CLEF Range (2.8.4.4.)	

a) $dK < 3.0$

You can configure each of the related parameters, to suit your particular application.

2.2.4. Damping Filter

The time constant for the damping filter. The damping filter smooths out the response to a sudden change in level. This is an exponential filter and the engineering unit is always in seconds (see Damping on page 130 for more detail).

Values	Range: 0 to 100.000 s
	Default: 10.000 s

2.2.5. Antenna

Read only. Identifies antenna configuration (Near Range [blanking] distance is automatically adjusted to suit).

2.3. Calibration

Note: We recommend using the Quick Start wizard to configure the device.

2.3.1. Low Calibration Pt.

Distance from sensor reference point ¹⁾ to Low Calibration Point. Units are defined in **Units (2.2.1.)**.

Values	Range: 0 to 20 m. Default 20.00 m
Related parameters	Units (2.2.1.) Far Range (2.8.2.)

¹⁾ The point from which level measurement is referenced (see *Dimensions: Uni-Construction Polypropylene Rod Antenna* on page 12 and *Appendix G: Flange Adapter Versions* on page 152).

2.3.2. High Calibration Pt.

*Distance from sensor reference point¹⁾ to High Calibration Point. Units are defined in **Units (2.2.1).***

Values	Range: 0 to 20 m. Default 0.00 m
Related parameters	Units (2.2.1) Near Range (2.8.1.)

When setting the High Calibration Point value, note that echoes are ignored within Near Range (see *Near Range (2.8.1.)* on page 129 for details).

2.3.3. Sensor Offset

A constant offset that can be added to or subtracted from sensor value¹⁾ to compensate if the sensor reference point has shifted. (For example, this could result from adding a thicker gasket or reducing the standoff/nozzle height).

Values	Range: -99.999 to +99.999. Default: 0.00
Related parameters	Units (2.2.1)

2.4. Rate

Note: Default settings in the parameter tables are indicated with an asterisk (*) unless explicitly stated.

2.4.1. Response Rate

Note: Changing Response Rate resets Fill Rate (2.4.2.), Empty rate (2.4.3.), and Damping Filter (2.2.4.).

Sets the reaction speed of the device to measurement changes.

Response Rate (2.4.1.)	Fill Rate (2.4.2.)	Empty rate (2.4.3.)	Damping Filter (2.2.4.)
* slow	0.1 m/min (0.32 ft/min)	10 s	10 s
medium	1.0 m/min (3.28 ft/min)	10 s	10 s
fast	10.0 m/min (32.8 ft/min)	0 s	0 s

Use a setting just faster than the maximum filling or emptying rate (whichever is faster).

¹⁾ The value produced by the echo processing which represents the distance from sensor reference point to the target. (see **Sensor Mode (2.2.2.)** on page 76 for an illustration).

2.4.2. Fill Rate

Defines the maximum rate at which the reported sensor value¹⁾ is allowed to increase. Allows you to adjust the SITRANS LR200 response to increases in the actual material level. Fill Rate is automatically updated whenever Response Rate is altered.

Options	Range: 0 to 99999 m / min.		
	Response Rate (2.4.1.)		Fill Rate
	*	Slow	0.1 m/min (0.32 ft/min)
		Medium	1.0 m/min (3.28 ft/min)
		Fast	10.0 m/min (32.8 ft/min)
Altered by:	Response Rate (2.4.1.)		
Related parameters	Units (2.2.1.)		

Enter a value slightly greater than the maximum vessel-filling rate, in units per minute.

2.4.3. Empty rate

Defines the maximum rate at which the reported sensor value²⁾ is allowed to decrease. Adjusts the SITRANS LR200 response to decreases in the actual material level. Empty Rate is automatically updated whenever Response Rate is altered.

Options	Range: 0 to 99999 m / min.		
	Response Rate (2.4.1.)		Empty Rate
	*	Slow	0.1 m/min (0.32 ft/min)
		Medium	1.0 m/min (3.28 ft/min)
		Fast	10.0 m/min (32.8 ft/min)
Altered by:	Response Rate (2.4.1.)		
Related parameters	Units (2.2.1.)		

Enter a value slightly greater than the vessel's maximum emptying rate, in units per minute.

- 1) The value produced by the echo processing which represents the distance from sensor reference point to the target (see **Sensor Mode (2.2.2.)** on page 76 for an illustration).
- 2) The value produced by the echo processing which represents the distance from sensor reference point to the target (see **Sensor Mode (2.2.2.)** on page 76 for an illustration).

2.5. Fail-safe

Note: Default settings in the parameter tables are indicated with an asterisk (*) unless explicitly stated.

2.5.1. Material Level

Note: The default setting depends whether your device is a standard or NAMUR NE 43-compliant device.

Defines the mA output to use when the Fail-safe Timer expires.

STANDARD DEVICE			
Options		HI	20.5 mA (max. mA Limit)
		LO	3.8 mA (min. mA Limit)
	*	HOLD	Last valid reading (default 22.6 mA)
		VALUE	User-selected value [defined in Level (2.5.3.)]

NAMUR NE 43-COMPLIANT DEVICE			
Options		HI	20.5 mA (max. mA Limit)
		LO	3.8 mA (min. mA Limit)
		HOLD	Last valid reading
	*	VALUE	User-selected value [defined in Level (2.5.3.) ; default 3.58 mA]

2.5.2. Timer

Note: When a Loss of Echo occurs **Material Level (2.5.1.)** determines the material level to be reported when the Fail-safe timer expires. See *Loss of Echo (LOE)* on page 132 for more detail.

Sets the time to elapse since the last valid reading, before the Fail-safe Level is reported.

Values	Range: 0.00 to 7200 seconds
	Default: 100 s

2.5.3. Level

Notes:

- The default setting depends whether your device is a standard or NAMUR NE 43-compliant device.
- **Material Level (2.5.1.)** must be set to **VALUE** to enable the Level value to be reported.

Allows the user to define the mA value to be reported when the Fail-safe timer expires.

Device Type		STANDARD	NAMUR NE43-COMPLIANT
Values	Range	3.56 mA to 22.6 mA	
	Default	22.60 mA	3.58 mA

2.6. Analog Output Scaling

2.6.1. Current Output Function

Notes:

- **Level, space, and distance**, have different reference points.
- Sensor Mode resets Current Output Function to the same setting. To select a different option, do so after Sensor Mode has been set.
- Use caution when changing Current Output Function while the device is connected to a HART network. Current Output Function controls the primary value and the loop current for the device.
- Current Output Function also affects the secondary, tertiary and quaternary variables in a HART network.

*Allows Current Output Function (2.6.1.) to be set independently from Sensor Mode. For example, Sensor Mode may be set to **Level** and Current Output Function (2.6.1.) set to **Distance**.*

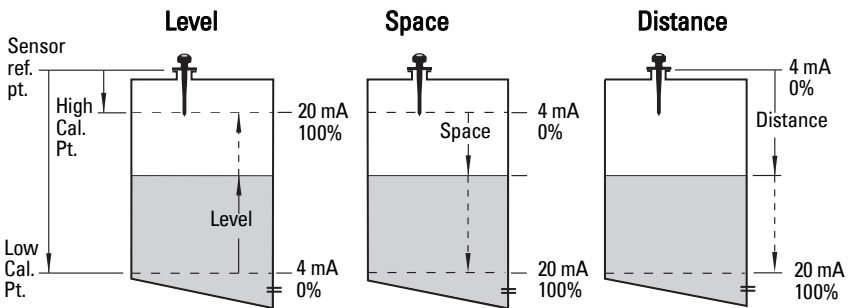

Options	Reference point	Description
* Level	Low Calibration Point	measured as a percentage of the difference between High Calibration Point and Low Calibration Point
Space	High Calibration Point	
Distance	sensor reference point	measured as a percentage of Low Calibration Point
Volume	converts a level measurement to a volume output	
Manual^{a)} (LUI only)	allows mA Output Value (2.6.6.) to be set to a user-defined value	

- a) Current Output Function must be set to **Manual** before modifying **mA Output Value (2.6.6.)**. Remember to restore the previous Current Output Function setting after modifying mA Output Value.

To modify Current Output Function via SIMATIC PDM:

- Open the menu **Device – Select Analog Output**. (See *Select Analog Output* on page 51 for more detail.)

2.6.2. Start of Scale (4 mA Setpoint)

*Sets the process level corresponding to the 4 mA value. 4 mA always defaults to 0, and **Current Output Function (2.6.1.)** determines whether this is a Level, Space, Distance, or Volume measurement. (See **Current Output Function (2.6.1.)** for an illustration.)*

Values	Range: -999999 to +999999
	Default: 0.00 m (set to value corresponding to 0% as defined by Current Output Function)
Related Parameters	Units (2.2.1.) Current Output Function (2.6.1.)

- Enter the reading that is to correspond to a 4 mA output.
- Units are defined in **Units (2.2.1.)** for Level, Space, or Distance. Units are unspecified for Volume.

2.6.3. Full Scale (20 mA Setpoint)

*Sets the process level corresponding to the 20 mA value. 20 mA always defaults to 100%, and **Current Output Function (2.6.1.)** determines whether this is a Level, Space, or Distance measurement. (See **Current Output Function (2.6.1.)** for an illustration.)*

Values	Range: -999999 to +999999
	Default: 20.00 m (set to value corresponding to 100% as defined by Current Output Function)
Related Parameters	Units (2.2.1.) Current Output Function (2.6.1.)

- Enter the reading that is to correspond to a 20 mA output.
- Units are defined in **Units (2.2.1.)** for Level, Space, or Distance. Units are unspecified for Volume.

2.6.4. Control Range; lower limit (Min. mA limit)

Prevents the mA output from dropping below this minimum level for a measurement value. This does not restrict the Fail-safe or Manual settings.

Values	Range: 3.8 to 20.5 (mA)
	Default: 3.80 (mA)

2.6.5. Control Range; upper limit (Max. mA limit)

Prevents the mA output from rising above this maximum level for a measurement value. This does not restrict the Fail-safe or Manual settings.

Values	Range: 3.8 to 20.5 (mA)
	Default: 20.50 (mA)

2.6.6. mA Output Value

Allows you to use a simulated value to test the functioning of the loop. You can enter 4 mA, 20 mA, or any other user-defined value within the range.

Values	Range: 3.56 mA to 22.6 mA
	Read Only unless Current Output Function (2.6.1.) is set to Manual .
Related parameter	Current Output Function (2.6.1.)

- First set **Current Output Function (2.6.1.)** to **Manual**.
- Enter the desired mA value in mA Output Value.
- After completing the test, remember to reset **Current Output Function (2.6.1.)** to the previous setting.

Via SIMATIC PDM:

Open the menu **Device – Loop Test**. (For more detail, see *Loop-Test* on page 52.)

2.7. Linearization

2.7.1. Volume

Carries out a volume conversion from a level value.

2.7.1.1. Vessel Shape

Defines the vessel shape and allows the LR200 to calculate volume instead of level. If **None** is selected, no volume conversion is performed. Select the vessel shape matching the monitored vessel or reservoir.

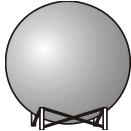
	Vessel Shape	LCD DISPLAY/ Description	Also required
*	None	NONE/ No volume calculation required	N/A
		CYLINDER/ Flat end horizontal cylinder	maximum volume
		SPHERE/ Sphere	maximum volume

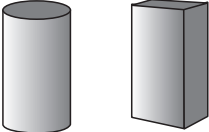
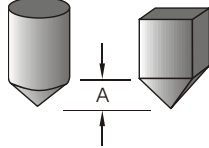
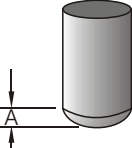
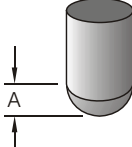
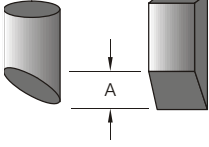
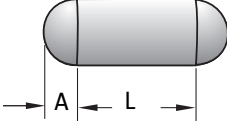
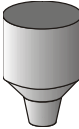
Vessel Shape (cont'd)	LCD DISPLAY/ Description	Also required
	LINEAR/ Upright, linear (flat bottom)	maximum volume
	CONICAL BOT/ Conical or pyramidal bottom	maximum volume, dimension A
	PARABOLIC BOT/Parabolic bottom	maximum volume, dimension A
	HALF SPHERE BOT/ Half-sphere bottom	maximum volume, dimension A
	FLAT SLOPED BOT/ Flat sloped bottom	maximum volume, dimension A
	PARABOLIC ENDS/ Parabolic end horizontal cyl- inder	maximum volume, dimension A, dimension L
	LINEAR TABLE ^{a)} / Linearization table (level/volume breakpoints)	maximum volume, tables 1-32 level and volume break- points

a) Linearization Table must be selected in order for level/volume values [see **Table 1-8 (2.7.2.)**] to be transferred.

2.7.1.2. Maximum Volume

The maximum volume of the vessel. Enter the vessel volume corresponding to High Calibration Point. For example, if your maximum vessel volume is 8000 L, enter a value of 8000. Volume units are defined by the user but are not explicitly stated in the SITRANS LR200

Values	Range: 0.0000 to 99999
	Default: 100.0
Related Parameters	Low Calibration Pt. (2.3.1.)
	High Calibration Pt. (2.3.2.)
	Vessel Shape (2.7.1.1.)

2.7.1.3. Dimension A

The height of the vessel bottom when the bottom is conical, pyramidal, parabolic, spherical, or flat-sloped. If the vessel is horizontal with parabolic ends, the depth of the end. See **Vessel Shape (2.7.1.1.)** for an illustration.

Values	Range: 0.0000 to 99999 mm
	Default: 0.0
Related Parameters	Units (1.4.)
	Vessel Shape (2.7.1.1.)

2.7.1.4. Dimension L

Length of the cylindrical section of a horizontal parabolic end vessel. See **Vessel Shape (2.7.1.1.)** for an illustration.

Values	Range: 0.0000 to 99999 mm
	Default: 0.0
Related Parameters	Units (1.4.)
	Vessel Shape (2.7.1.1.)

2.7.2. Table 1-8

Note: Linearization Table must be selected in **Vessel Shape (2.7.1.1.)** in order for level/volume values to be transferred.

If your vessel shape is more complex than any of the preconfigured shapes, you can define the shape as a series of segments. A value is assigned to each level breakpoint and a corresponding value is assigned to each volume breakpoint. Level values are defined in **Units (2.2.1.)**. Volume units are defined by the user but are not explicitly stated in the SITRANS LR200.

Level Values	Range: 0.0000 to 99999 mm
	Default: 0.0
Volume Values	Range: 0.0000 to 99999
	Default: 0.0

Enter up to 32 level breakpoints, where the corresponding volume is known. The values corresponding to 100% and 0% levels must be entered. The breakpoints can be ordered from top to bottom, or the reverse.

Breakpoints are grouped into four tables: Table 1-8, Table 9-16, Table 17-24, and Table 25-32.

Entering breakpoints via SIMATIC PDM:

- See *Using Linearization via the Quick Start wizard* on page 41 .

Entering breakpoints via the handheld programmer:

- The default unit for level values is **m**: to change it navigate to **Setup (2.) > Sensor (2.2.) > Units (2.2.1.)**, and select the desired unit.
- Navigate to **Setup (2.) > Linearization (2.7.) > Maximum Volume (2.7.1.2.)**, and enter the value.
- Go to the appropriate table for the particular breakpoint you wish to adjust: for example, go to Table 1-8 for breakpoint 1.
- Under Table 1-8, go to **Level 1 (2.7.2.1.)** to enter the level value for the breakpoint 1.
- Under Table 1-8, go to **Volume 1 (2.7.2.2.)** to enter the volume value for the breakpoint 1
- Repeat steps c) to e), till values have been entered for all required breakpoints.

2.7.2.1. Level 1

- Press **RIGHT arrow** to open Edit mode.
- Enter level value and press **RIGHT arrow** to accept it.
- Press **Down ARROW** to move to corresponding volume breakpoint.

2.7.2.2. Volume 1

- Press **RIGHT arrow** to open Edit mode.
- Enter volume value and press **RIGHT arrow** to accept it.
- Press **Down ARROW** to move to next level breakpoint.

Example (values are for example purposes only)

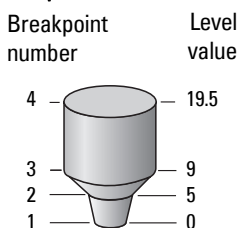

Breakpoint Number	Level value (m)	Volume value (l)
1	0	0
2	5	500
3	9	3000
4	19.5	8000

2.7.3. Table 9-16

2.7.4. Table 17-24

2.7.5. Table 25-32

2.8. Signal Processing

Note: Default settings in the parameter tables are indicated with an asterisk (*) unless explicitly stated.

2.8.1. Near Range

The range in front of the device (measured from the sensor reference point) within which any echoes will be ignored. This is sometimes referred to as blanking or a dead zone. The factory set range is dependent on the antenna type.

Values	Range: 0 to 20 m (0 to 65.6 ft).
	Default: Depends on the antenna. 0.3 m (1 ft), plus any shield length, from the sensor reference point ^{a)} 100 mm shield version default is 0.42 m (0.3 m plus 0.12 m from device reference to the end of the shield). See also <i>Min. detectable distance1</i>) on page 6 .

- a) For the reference point for each configuration, see *Dimensions: Uni-Construction Polypropylene Rod Antenna* on page 12 for the standard version, or *Appendix G: Flange Adapter Versions*, page 152 onwards.

2.8.2. Far Range

Note: Far Range can extend beyond the bottom of the vessel.

*Allows the material level to drop below Low Calibration Point without generating a Loss of Echo (LOE) state. See **Sensor Mode (2.2.2.)** on page 76 for an illustration.*

Values	Range: 0 to 23 m (0 to 75.4 ft). Min. value depends on the setting for Low Calibration Pt. (2.3.1.) .
	Default: Low Calibration Point setting + 1 m (3.2 ft)

Use this feature if the measured surface can drop below the Low Cal. Point in normal operation.

2.8.3. Propagation Factor

Notes:

- When operating with a waveguide antenna or stillpipe, values for **CLEF Range (2.8.4.4.)** on page 89, and for the propagation factor, should be set according to the antenna frequency and the antenna/pipe size. See the tables below.
- For reliable results the horn size must be close to the pipe size.

Compensates for the change in microwave velocity due to propagation within a metal stillpipe instead of in free space.

5.8 GHz Model					
Values	Range: 0.3 to 1.5 depending on pipe size.				
	Default: 1.000				
Antenna/Pipe Size (I.D.) ^{a)}	50 mm (2")	80 mm (3")	100 mm (4")	150 mm (6")	200 mm (8")
Propagation Factor	0.7953	0.9254	0.9530	0.9794	0.9884

- a) Since pipe dimensions may vary slightly, the propagation factor may also vary.

6.3 GHz Model					
Values	Range: 0.3 to 1.5 depending on pipe size.				
	Default: 1.000				
Antenna/Pipe Size (I.D.) ^{a)}	50 mm (2")	80 mm (3")	100 mm (4")	150 mm (6")	200 mm (8")
Propagation Factor	0.8298	0.9372	0.9603	0.9825	0.9902

- a) Since pipe dimensions may vary slightly, the propagation factor may also vary.

2.8.4. Echo select

2.8.4.1. Algorithm

Selects the algorithm to be applied to the echo profile to extract the true echo.

Options	*	tF	true First echo
		L	Largest echo
		BLF	Best of First or Largest echo

2.8.4.2. Position Detect

Defines where on the echo the distance measurement is determined. See Position Detect (2.8.4.2.) on page 125 for more detail.

Options		Center
	*	Hybrid (Center and CLEF)
		CLEF (Constrained Leading Edge Fit)
Related parameters		CLEF Range (2.8.4.4.)

If the vessel bottom is being reported as the level instead of the actual material level (at low level conditions), or if the dielectric constant of the liquid to be monitored is less than 3, we recommend setting **Position Detect (2.8.4.2.)** to Hybrid and **CLEF Range (2.8.4.4.)** to 0.5 m (1.64 ft).

2.8.4.3. Echo Threshold

Sets the minimum echo confidence that the echo must meet in order to prevent a Loss of Echo condition and the expiration of the Fail-safe (LOE) timer. When **Confidence (2.8.6.1.)** exceeds **Echo Threshold (2.8.4.3.)**, the echo is accepted as a valid echo and is evaluated.

Values	Range: 0 to 99
	Default: 5
Related Parameters	Timer (2.5.2.)

Use this feature when an incorrect material level is reported.

2.8.4.4. CLEF Range

Note: CLEF Range is referenced from Low Calibration Point (process empty level).

The CLEF algorithm is used mainly to allow correct level reporting for low dK materials which may otherwise cause an incorrect reading in an empty or almost empty vessel.

It is used from Low Calibration Point (process empty level) up to the level defined by CLEF range (see illustration below). Above that point the Center algorithm is used. For more detail see CLEF Range (2.8.4.4.) on page 127.

Values	Range: 0 to 20 m (0 to 65.6 ft)
	Default: 0.00 m
Related parameters	Position Detect (2.8.4.2.)

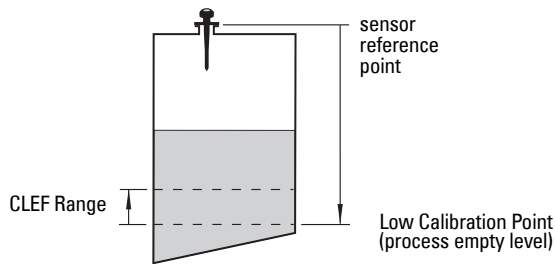

In applications with low dK materials we recommend setting CLEF Range to 0.5 m (1.64 ft) and **Position Detect (2.8.4.2.)** to **Hybrid**.

2.8.5. Sampling

Provides a method of checking the reliability of a new echo before accepting it as the valid reading, based on numbers of samples above or below the currently selected echo.

2.8.5.1. Echo Lock

Note: Ensure the agitator is always running while SITRANS LR200 is monitoring the vessel, to avoid stationary blade detection.

Selects the measurement verification process.

Options	Lock Off
	Maximum Verification (not recommended for radar)
	* Material Agitator
	Total Lock (not recommended for radar)
Related parameters	Fill Rate (2.4.2.) Empty rate (2.4.3.) Sampling Up (2.8.5.2.) Sampling Down (2.8.5.3.)

For radar applications, Material Agitator is the most often-used setting, to avoid agitator blade detection.

2.8.5.2. Sampling Up

Specifies the number of consecutive echoes that must appear above the echo currently selected, before the measurement is accepted as valid.

Values	Range: 1 to 50
	Default: 5

2.8.5.3. Sampling Down

Specifies the number of consecutive echoes that must appear below the echo currently selected, before the measurement is accepted as valid.

Values	Range: 1 to 50
	Default: 2

2.8.6. Echo Quality

2.8.6.1. Confidence

*Indicates echo reliability: higher values represent better echo quality. The display shows the echo confidence of the last measurement. **Echo Threshold (2.8.4.3.)** defines the minimum criterion for echo confidence.*

Values (view only)	0 to 99	
	----	Shot not used
Related Parameters	Echo Threshold (2.8.4.3.)	

Open the menu **View – Echo Profile**.

2.8.6.2. Echo Strength

Displays the absolute strength (in dB above 1 μ V rms) of the echo selected as the measurement echo.

Values (view only)	-20 to 99
---------------------------	-----------

Open the menu **View – Echo Profile**.

2.8.6.3. Noise Average

Displays the average ambient noise (in dB above 1 μ V rms) of a noise profile. Noise level is a combination of transient noise and receiving circuitry. After a measurement, the values from the previous noise shot will be displayed.

2.8.7. TVT setup

Note: Default settings in the parameter tables are indicated with an asterisk (*) unless explicitly stated.

2.8.7.1. Auto False Echo Suppression

Used together with **Auto False Echo Suppression Range (2.8.7.2.)** to screen out false echoes in a vessel with known obstructions. A 'learned TVT' (time varying threshold) replaces the default TVT over a specified range. See **Auto False Echo Suppression (2.8.7.1.)** on page 128 for a more detailed explanation.

Notes:

- Make sure material level is below all known obstructions when Auto False Echo Suppression is used to learn the echo profile. (An empty or almost empty vessel is recommended.)
- Note the distance to material level when Auto False Echo learns the environment. Set Auto False Echo Suppression Range to a shorter distance to avoid the material echo being screened out.
- Set Auto False Echo Suppression and Auto False Echo Suppression Range during startup, if possible.
- If the vessel contains an agitator it should be running.
- Before adjusting these parameters, rotate the instrument for best signal (lower false-echo amplitude).

Before Auto False Echo Suppression

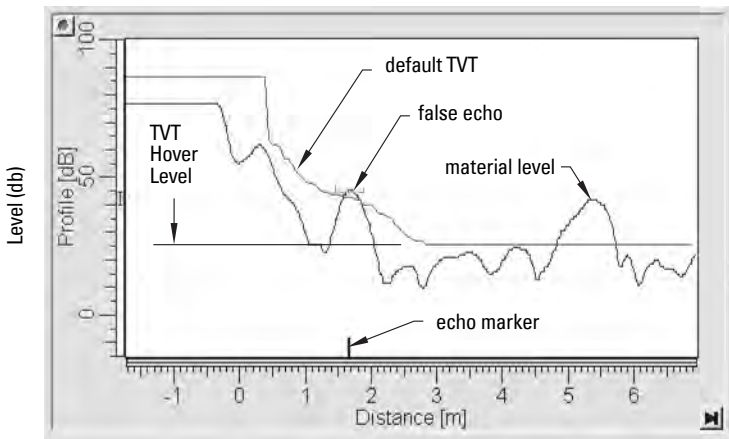

- a) Determine Auto False Echo Suppression Range. Measure the actual distance from the sensor reference point to the material surface using a rope or tape measure.
- b) Subtract 0.5 m (20") from this distance, and use the resulting value.

After Auto False Echo Suppression

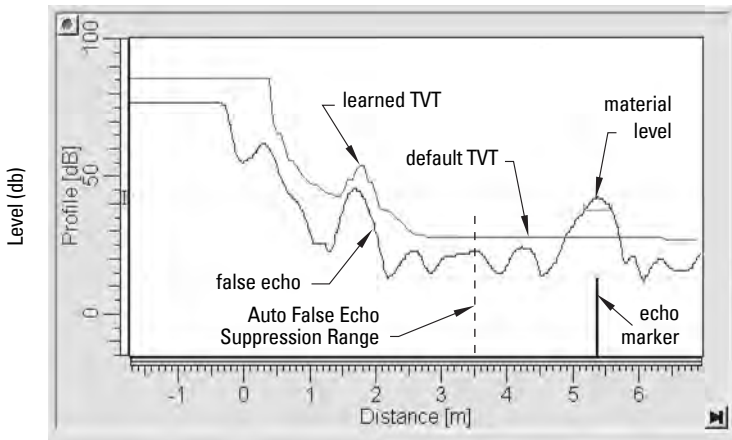

To set Auto False Echo Suppression via SIMATIC PDM:

Open the menu **Device – Echo Profile Utilities** and click on the tab **Auto False Echo Suppression**.

(For more detailed instructions see *Auto False Echo Suppression* on page 48.)

To set Auto False Echo Suppression via the handheld programmer:

Options		OFF	Default TVT will be used.
	*	ON	'Learned' TVT will be used.
		LEARN	'Learn' the TVT.

- Go to **Auto False Echo Suppression Range (2.8.7.2.)** and enter the value calculated in step b).
- Go to **Auto False Echo Suppression (2.8.7.1.)** and press **RIGHT arrow** to open Edit Mode
- Select **Learn**. The device will automatically revert to **On** (Use Learned TVT) after a few seconds.

2.8.7.2. Auto False Echo Suppression Range

Specifies the range within which Learned TVT is used (see Auto False Echo Suppression (2.8.7.1.) on page 128 for more detail).

Values	Range: 0.00 to 20.00 m
	Default: 1.00 m
Related parameters	Units (1.4.)

- Calculate range according to **Auto False Echo Suppression (2.8.7.1.)** steps a) and b).
- Press **RIGHT arrow** to open Edit mode.
- Enter the new value and press **RIGHT arrow** to accept it.
- Set **Auto False Echo Suppression (2.8.7.1.)**.

2.8.7.3. Hover Level

*Defines how high the TVT (Time Varying Threshold) is placed above the noise floor of the echo profile, as a percentage of the difference between the peak of the largest echo in the profile and the noise floor. See **Before Auto False Echo Suppression** on page 92 for an illustration.*

Values	Range: 0 to 100%
	Default: 40%

When the device is located in the center of the vessel, the TVT hover level may be lowered to increase the confidence level of the largest echo.

2.8.7.4. Shaper Mode

Enables/disables the TVT shaper.

Options		ON
	*	OFF

2.8.8. TVT shaper

Notes:

- The range is –100 to 100 bits. With 2 bits per dB this gives a range of –50 to 50 dB.
- **Shaper Mode (2.8.7.4.)** must be turned ON in order for TVT shaper points to be transferred

Adjusts the TVT (Time Varying Threshold) at a specified range (breakpoint on the TVT). This allows you to reshape the TVT to avoid unwanted echoes. There are 40 breakpoints arranged in 5 groups. (We recommend using SIMATIC PDM to access this feature.)

To use TVT shaper via SIMATIC PDM:

- Open the menu **Device – Echo Profile Utilities** and click on **TVT Shaper**. For more detail see *TVT Shaper* on page 47 .

To use TVT shaper via LUI (local user interface):

- a) Go to Breakpoint 1-9 (2.8.8.1).
- b) Open Shaper 1 and enter the TVT Offset value (between –50 and 50).
- c) Go to the next Shaper point and repeat steps c) and d) till all desired breakpoint values have been entered.

2.8.8.1. Breakpoint 1-9

Values	Range: –50 to 50 dB
	Default: 0 dB

2.8.8.2. Breakpoint 10-18

Values	Range: -50 to 50 dB
	Default: 0 dB

2.8.8.3. Breakpoint 19-27

Values	Range: -50 to 50 dB
	Default: 0 dB

2.8.8.4. Breakpoint 28-36

Values	Range: -50 to 50 dB
	Default: 0 dB

2.8.8.5. Breakpoint 37-40

Values	Range: -50 to 50 dB
	Default: 0 dB

2.8.9. Measured Values

Read only. Allows you to view Measured Values for diagnostic purposes.

To access Measured Values via SIMATIC PDM:

Open the menu **View – Process Variables**.

2.8.9.1. Level Measurement

The value for level.

2.8.9.2. Space Measurement

The value for space.

2.8.9.3. Distance Measurement

The value for distance.

2.8.9.4. Volume Measurement

The value for volume.

3. Diagnostics

3.1. Echo Profile

Allows you to request the current echo profile either locally via the handheld programmer, or remotely. Remote options are:

- SIMATIC PDM (see *Echo profile* on page 46)
- AMS Device Manager (see *Echo Profile* on page 65)

To request a profile via SIMATIC PDM open the menu **Device – Echo Profile Utilities**.
(For more detail see *Echo Profile Utilities* on page 45 .)

To request a profile via the handheld programmer:

- a) In PROGRAM mode, navigate to **LEVEL METER > DIAGNOSTICS (3) > ECHO PROFILE (3.1)**
- b) Press **RIGHT arrow** to request a profile.

For more detail see *Requesting an Echo Profile* on page 33 .

3.2. Electronics Temperature

3.2.1. Current Internal Temperature

Read only. Displays (in degrees C) the current temperature on the circuit board recorded by the internal electronics.

For access via SIMATIC PDM open the menu **View – Process Variables** and check the field **Electronics Temperature**.

3.2.2. Highest value

Read only. Displays (in degrees C) the maximum temperature recorded by the internal electronics. The high and low values are maintained over a power cycle.

Via SIMATIC PDM navigate to **Maintenance and Diagnostics > Electronics Temperature**.

3.2.3. Lowest value

Read only. Displays (in degrees C) the minimum temperature recorded by the internal electronics. The high and low values are maintained over a power cycle.

Via SIMATIC PDM navigate to **Maintenance and Diagnostics > Electronics Temperature**.

4. Service

Note: Default settings in the parameter tables are indicated with an asterisk (*) unless explicitly stated.

4.1. Master Reset

Note: Following a reset to **Factory Defaults**, complete reprogramming is required.

Resets user parameters to factory defaults, with certain exceptions. The list of exceptions includes, but is not limited to, Tag, Message, Description, Installation Data, Device Address, Write Protect and PIN to Unlock. Auto False Echo Suppression Range and the learned TVT also remain unchanged.

Options	*	Idle or Done (Return to previous menu)
		Factory Defaults

To perform a reset to factory defaults via SIMATIC PDM, open the menu **Device – Master Reset** and click on **Factory Defaults**.

4.2. Remaining Device Lifetime

Notes:

- Default settings in the parameter tables are indicated with an asterisk (*) unless explicitly stated.
- Four sets of parameters allow you to monitor the Device/Sensor Lifetimes and set up Maintenance/Service schedules, based on operating hours instead of a calendar-based schedule. See also **Remaining Sensor Lifetime (4.3.)**, **Service Schedule (4.4.)**, and **Calibration Schedule (4.5.)**.
- Performing a reset to **Factory Defaults** will reset all the Maintenance Schedule parameters to their factory defaults.
- The device operates in years. To view Remaining Device Lifetime parameters in hours or days (via SIMATIC PDM only) see **Lifetime Expected (4.2.1.)**.

The device tracks itself based on operating hours and monitors its predicted lifetime. You can modify the expected device lifetime, set up schedules for maintenance reminders, and acknowledge them.

The maintenance warnings and reminders are available through HART communications. This information can be integrated into an Asset Management system. For optimal use, we recommend that you use SIMATIC PCS7 Asset Management Software in conjunction with SIMATIC PDM.

To access these parameters via SIMATIC PDM:

- Open the menu **Device – Maintenance** and select the **Remaining Device Lifetime** tab.
- After modifying values/units as required, click on **Write** to accept the change, and **Read** to view the effect of the change.
- Click on **Snooze** to add a year to the Total Expected Device Life.

Time Units

Options ^{a)}	Hours; days; years
	Default: years

a) Selectable only via SIMATIC PDM.

4.2.1. Lifetime Expected

Note: The device always operates in years. Changing the units affects only the parameter view of the Remaining Device Lifetime parameters in SIMATIC PDM.

Allows you to override the factory default.

Values	Units ^{a)} : hours, days, years
	Range: 0 to 20 years
	Default: 10.00 years

a) Units are selectable only via SIMATIC PDM.

4.2.2. Time in Operation

Read only. The amount of time the device has been operating.

4.2.3. Remaining Lifetime

Read only. Lifetime Expected (4.2.1.) less Time in Operation (4.2.2.).

4.2.4. Reminder Activation

Note: To modify this parameter via SIMATIC PDM it must be accessed via the pull-down menu **Device – Maintenance**.

Allows you to enable a maintenance reminder

Options		Reminder 1 (Maintenance Required)
		Reminder 2 (Maintenance Demanded)
		Reminders 1 and 2(Required and Demanded)
	*	OFF

- First set the values in **Reminder 1 (Required) (4.2.5.)**/**Reminder 2 (Demanded) (4.2.6.)**.
- Select the desired **Reminder Activation** option.

4.2.5. Reminder 1 (Required)

*If **Remaining Lifetime (4.2.3.)** is equal to or less than this value, the device generates a Maintenance Required reminder.*

Values	Range: 0 to 20 years
	Default: 0.16 years

- Modify values as required.
- Set **Reminder Activation (4.2.4.)** to the desired option.

4.2.6. Reminder 2 (Demanded)

*If **Remaining Lifetime (4.2.3.)** is equal to or less than this value, the device generates a Maintenance Demanded reminder.*

Values	Range: 0 to 20 years
	Default: 0.02 years

- Modify values as required.
- Set **Reminder Activation (4.2.4.)** to the desired option.

4.2.7. Maintenance Status

Indicates which level of maintenance reminder is active.

In SIMATIC PDM, open the menu **View – Device Status**, click on the **Maintenance** tab, and check the **Device Lifetime Status** window.

4.2.8. Acknowledge Status

Indicates which level of maintenance reminder has been acknowledged.

In SIMATIC PDM, open the menu **View – Device Status**, click on the **Maintenance** tab, and check the **Device Lifetime Status** window.



4.2.9. Acknowledge

Acknowledges the current maintenance reminder.

To acknowledge a reminder via SIMATIC PDM:

- a) Open the menu **View – Device Status** and click on the tab **Maintenance**.
- b) In the **Device Lifetime** section, click on **Acknowledge Warnings**.

To acknowledge a reminder via the handheld programmer:

- a) Press **RIGHT arrow**  twice to open parameter view and activate **Edit Mode**.
- b) Press **RIGHT arrow**  to acknowledge the reminder.

4.3. Remaining Sensor Lifetime

Notes:

- Default settings in the parameter tables are indicated with an asterisk (*) unless explicitly stated.
- Four sets of parameters allow you to monitor the Device/Sensor Lifetimes and set up Maintenance/Service schedules, based on operating hours instead of a calendar-based schedule. See also **Remaining Device Lifetime (4.2)**, **Service Schedule (4.4)**, and **Calibration Schedule (4.5)**.
- Performing a reset to **Factory Defaults** will reset all the Maintenance Schedule parameters to their factory defaults.
- The device operates in years. To view Remaining Sensor Lifetime parameters in hours or days (via SIMATIC PDM only) see **Lifetime Expected (4.3.1)**.

The device monitors the predicted lifetime of the sensor (the components exposed to the vessel environment). You can modify the expected sensor lifetime, set up schedules for maintenance reminders, and acknowledge them.

To access these parameters via SIMATIC PDM:

- Open the menu **Device – Maintenance** and select the **Remaining Sensor Lifetime** tab.
- After modifying values/units as required, click on **Write** to accept the change, and **Read** to view the effect of the change.
- Click on **Snooze** to add a year to the Total Expected Sensor Life.
- Click on **Sensor Replaced** to restart the timer and clear any fault messages.



Time Units

Options^{a)}	Hours; days; years
	Default: years

a) Selectable only via SIMATIC PDM.

4.3.1. Lifetime Expected

Note: The device always operates in years. Changing the units affects only the parameter view of Remaining Sensor Life parameters in SIMATIC PDM.

Allows you to override the factory default.

Values	Units ^{a)} : hours, days, years
	Range: 0 to 20 years
	Default: 10.00 years

a) Units are selectable only via SIMATIC PDM.

4.3.2. Time in Operation

The amount of time the sensor has been operating. Can be reset to zero after performing a service or replacing the sensor.

To reset to zero:

- In SIMATIC PDM, open the menu **Device – Maintenance**, click on the **Remaining Sensor Lifetime** tab, and click on **Sensor Replaced** to restart the timer and clear any fault messages.
- Via the handheld programmer, manually reset **Time in Operation (4.3.2.)** to zero.

4.3.3. Remaining Lifetime

Read only. Lifetime Expected (4.3.1.) less Time in Operation (4.3.2.)

4.3.4. Reminder Activation

Note: To modify this parameter via SIMATIC PDM it must be accessed via the pull-down menu **Device – Maintenance**.

Allows you to enable a maintenance reminder.

Options	Reminder 1 (Maintenance Required)
	Reminder 2 (Maintenance Demanded)
	Reminders 1 and 2
	* OFF

- First set the values in **Reminder 1 (Required) (4.3.5.)**/**Reminder 2 (Demanded) (4.3.6.)**.
- Select the desired **Reminder Activation** option.

4.3.5. Reminder 1 (Required)

If Remaining Lifetime (4.3.3.) is equal to or less than this value, the device generates a Maintenance Required reminder.

Values	Range: 0 to 20 years
	Default: 0.164 years

- Modify values as required.
- Set **Reminder Activation (4.3.4.)** to the desired option.

4.3.6. Reminder 2 (Demanded)

If Remaining Lifetime (4.3.3.) is equal to or less than this value, the device generates a Maintenance Demanded reminder.

Values	Range: 0 to 20 years
	Default: 0.019 years

- Modify values as required.
- Set **Reminder Activation (4.3.4.)** to the desired option.

4.3.7. Maintenance Status

Indicates which level of maintenance reminder is active.

In SIMATIC PDM, open the menu **View – Device Status**, click on the **Maintenance** tab, and check the **Sensor Lifetime Status** window.

4.3.8. Acknowledge Status

Indicates which level of maintenance reminder has been acknowledged.

In SIMATIC PDM, open the menu **View – Device Status**, click on the **Maintenance** tab and check the **Sensor Lifetime Status** window.



4.3.9. Acknowledge

Acknowledges the current maintenance reminder.

To acknowledge a reminder via SIMATIC PDM:

- a) Open the menu **View – Device Status** and click on the tab **Maintenance**.
- b) In the **Device Lifetime** section, click on **Acknowledge Warnings**.

To acknowledge a reminder via the handheld programmer:

- a) Press **RIGHT arrow**  twice to open parameter view and activate **Edit Mode**.
- b) Press **RIGHT arrow**  to acknowledge the reminder.

4.4. Service Schedule

Notes:

- Four sets of parameters allow you to monitor the Device/Sensor Lifetimes and set up Maintenance/Service schedules, based on operating hours instead of a calendar-based schedule. See also **Remaining Device Lifetime (4.2.)**, **Remaining Sensor Lifetime (4.3.)**, and **Calibration Schedule (4.5.)**.
- Performing a reset to **Factory Defaults** will reset all the Maintenance Schedule parameters to their factory defaults.
- The device operates in years. To view Service Interval parameters in hours or days (via SIMATIC PDM only) see **Service Interval (4.4.1.)**.

The device tracks service intervals based on operating hours and monitors the predicted lifetime to the next service. You can modify the Total Service Interval, set schedules for maintenance reminders, and acknowledge them.

The maintenance warnings and reminders are communicated to the end user through status information. This information can be integrated into any Asset Management system. For optimal use, we recommend that you use SIMATIC PCS7 Asset Management Software in conjunction with SIMATIC PDM.

To access these parameters via SIMATIC PDM:

- Open the menu **Device – Maintenance** and select the **Service Schedule** tab.
- After modifying values/units as required, click on **Write** to accept the change, and **Read** to view the effect of the change.
- Click on **Service Performed** to restart the timer and clear any fault messages.
(see illustration on next page)

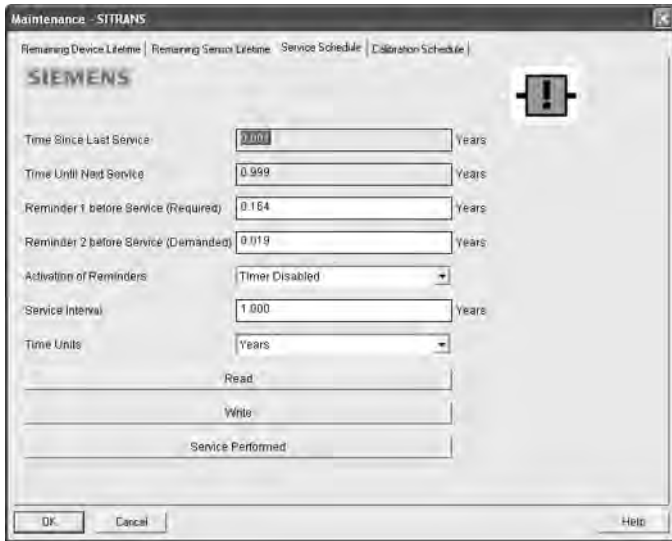

Time Units

Options ^{a)}	Hours; days; years
	Default: years

a) Selectable only via SIMATIC PDM.

4.4.1. Service Interval

Note: The device always operates in years. Changing the units affects only the parameter view of the Service Interval parameters in SIMATIC PDM.

User-configurable recommended time between product inspections.

Values	Units ^{a)} : hours, days, years
	Range: 0 to 20 years
	Default: 1.0 year

a) Units are selectable only via SIMATIC PDM.

4.4.2. Time since Last Service

Time elapsed since last service. Can be reset to zero after performing a service.

To reset to zero:

- In SIMATIC PDM, open the menu **Device – Maintenance**, click on the **Service Schedule** tab, and click on **Service Performed** to restart the timer and clear any fault messages.
- Via the handheld programmer, manually reset **Time since Last Service (4.4.2.)** to zero.

4.4.3. Time until Next Service

Read only. *Time Units (t) less Time since Last Service (4.4.2).*

4.4.4. Reminder Activation

Note: To modify this parameter via SIMATIC PDM it must be accessed via the pull-down menu **Device – Maintenance**.

Allows you to enable a maintenance reminder.

Values	*	Timer OFF
		ON - no reminders checked
		ON - Reminder 1 (Maintenance Required) checked
		ON - Reminders 1 and 2 checked
		ON -Reminder 2 (Maintenance Demanded) checked

- First set the values in **Reminder 1 (Required) (4.4.5.)**/**Reminder 2 (Demanded) (4.4.6.)**.
- Select the desired **Reminder Activation** option.

4.4.5. Reminder 1 (Required)

*If Time until Next Service (4.4.3.) is equal to or less than this value, the device generates a **Maintenance Required** reminder.*

Values	Range: 0 to 20 years
	Default: 0.164 years

- Modify values as required.
- Set **Reminder Activation (4.4.4.)** to the desired option.

4.4.6. Reminder 2 (Demanded)

*If Time until Next Service (4.4.3.) is equal to or less than this value, the device generates a **Maintenance Demanded** reminder.*

Values	Range: 0 to 20 years
	Default: 0.019 years

- Modify values as required.
- Set **Reminder Activation (4.4.4.)** to the desired option.

4.4.7. Maintenance Status

Indicates which level of maintenance reminder is active.

Open the menu **View – Device Status**, click on the **Maintenance** tab and check the **Service Schedule Status** window.

4.4.8. Acknowledge Status

Indicates which level of maintenance reminder has been acknowledged.

Open the menu **View – Device Status**, click on the **Maintenance** tab and check the **Service Schedule Status** window.



4.4.9. Acknowledge

Acknowledges the current maintenance reminder.

To acknowledge a reminder via SIMATIC PDM:

- a) Open the menu **View – Device Status** and click on the tab **Maintenance**.
- b) In the **Device Lifetime** section, click on **Acknowledge Warnings**.

To acknowledge a reminder via the handheld programmer:

- a) Press **RIGHT arrow**  twice to open parameter view and activate **Edit Mode**.
- b) Press **RIGHT arrow**  to acknowledge the reminder.

4.5. Calibration Schedule

Notes:

- Default settings in the parameter tables are indicated with an asterisk (*) unless explicitly stated.
- Four sets of parameters allow you to monitor the Device/Sensor Lifetimes and set up Maintenance/Service schedules, based on operating hours instead of a calendar-based schedule. See also **Remaining Device Lifetime (4.2.)**, **Remaining Sensor Lifetime (4.3.)**, and **Service Schedule (4.4.)**.
- Performing a reset to **Factory Defaults** will reset all the Maintenance Schedule parameters to their factory defaults.
- The device operates in years. To view Calibration Interval parameters in hours or days (via SIMATIC PDM only) see **Calibration Interval (4.5.1.)**.

The device tracks calibration intervals based on operating hours and monitors the predicted lifetime to the next calibration. You can modify the Total Calibration Interval, set schedules for maintenance reminders, and acknowledge them.

To access these parameters via SIMATIC PDM:

- Open the menu **Device – Maintenance** and select the **Calibration Schedule** tab.
- After modifying values/units as required, click on **Write** to accept the change, and **Read** to view the effect of the change.
- Click on **Calibration Performed** to restart the timer and clear any fault messages.

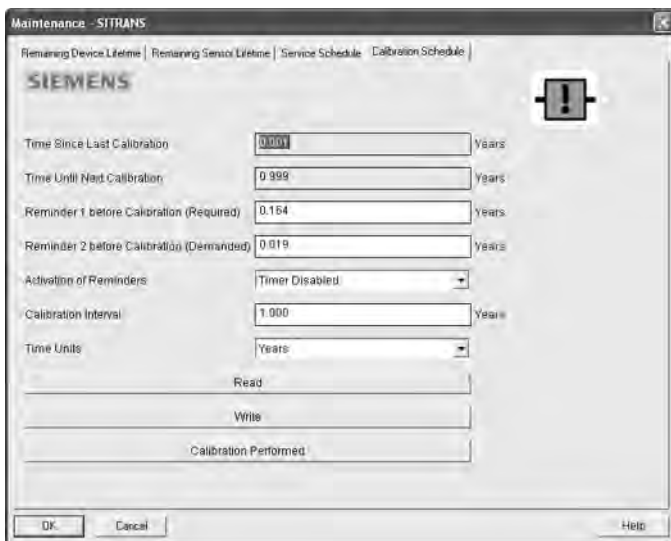

Time Units

Options^{a)}	Hours; days; years
	Default: years

a) Selectable only via SIMATIC PDM.

4.5.1. Calibration Interval

Note: The device always operates in years. Changing the units affects only the parameter view of the Calibration Interval parameters in SIMATIC PDM.

User-configurable recommended time between product calibrations.

Values	Units ^{a)} : hours, days, years
	Range: 0 to 20 years
	Default: 1.0 year

a) Units are selectable only via SIMATIC PDM.

4.5.2. Time since Last Calibration

Time elapsed since last calibration. Can be reset to zero after performing a calibration.

To reset to zero:

- In SIMATIC PDM, open the menu **Device – Maintenance**, click on the **Calibration Schedule** tab, and click on **Calibration Performed** to restart the timer and clear any fault messages.
- Via the handheld programmer, manually reset Time since Last Calibration (4.5.2.) to zero.

4.5.3. Time until Next Calibration

Read only. Calibration Interval (4.5.1.) less Time since Last Calibration (4.5.2).

4.5.4. Reminder Activation

Note: To modify this parameter via SIMATIC PDM it must be accessed via the pull-down menu **Device – Maintenance**.

Allows you to enable a maintenance reminder.

Values	*	Timer OFF
		ON - no reminders checked
		ON - Reminder 1 (Maintenance Required) checked
		ON - Reminders 1 and 2 checked
		ON - Reminder 2 (Maintenance Demanded) checked

- First set the values in **Reminder 1 (Required) (4.3.5./Reminder 2 (Demanded) (4.5.6.)**.
- Select the desired **Reminder Activation** option.

4.5.5. Reminder 1 (Required)

*If Time until Next Calibration (4.5.3.) is equal to or less than this value, the device generates a **Maintenance Required** reminder.*

Values	Range: 0 to 20 years
	Default: 0.164 years

- Modify values as required.
- Set **Reminder Activation (4.5.4.)** to the desired option.

4.5.6. Reminder 2 (Demanded)

*If Time until Next Calibration (4.5.3.) is equal to or less than this value, the device generates a **Maintenance Demanded** reminder.*

Values	Range: 0 to 20 years
	Default: 0.019 years

- Modify values as required.
- Set **Reminder Activation (4.5.4.)** to the desired option.

4.5.7. Maintenance Status

Indicates which level of maintenance reminder is active.

In SIMATIC PDM, open the menu **View – Device Status**, click on the **Maintenance** tab and check the **Calibration Schedule Status** window.

4.5.8. Acknowledge Status

Indicates which level of maintenance reminder has been acknowledged.

In SIMATIC PDM, open the menu **View – Device Status**, click on the **Maintenance** tab and check the **Calibration Schedule Status** window.



4.5.9. Acknowledge

Acknowledges the current maintenance reminder.

To acknowledge a reminder via SIMATIC PDM:

- a) Open the menu **View – Device Status** and click on the tab **Maintenance**.
- b) In the **Device Lifetime** section, click on **Acknowledge Warnings**.

To acknowledge a reminder via the handheld programmer:

- a) Press **RIGHT arrow**  twice to open parameter view and activate **Edit Mode**.
- b) Press **RIGHT arrow**  to acknowledge the reminder.

4.6. Manufacture Date

The date of manufacture of the SITRANS LR200 (yy mm dd).

4.7. Powered Hours

Displays the number of hours the unit has been powered up since manufacture.

In SIMATIC PDM, open the menu **View – Wear**.

4.8. Power-on Resets

The number of power cycles that have occurred since manufacture.

In SIMATIC PDM, open the menu **View – Wear**.

4.9. LCD Fast Mode

Notes:

- LCD Fast Mode takes effect only after 30 minutes of inactivity. (Each time the device is powered up, a further 30 minutes of inactivity is required.)
- LCD Fast Mode affects Measurement mode only; it has no effect on Navigation mode.

Enables a faster rate of measurement from the device by disabling most of the display area. Only the bar graph will be refreshed when LCD Fast Mode is set to ON.

Values	ON or OFF
---------------	------------------

4.10. LCD Contrast

The factory setting is for optimum visibility at room temperature and in average light conditions. Extremes of temperature will lessen the contrast.

Values	Range: 0 (High contrast) to 20 (Low contrast). Default: 10
---------------	---

Adjust the value to improve visibility in different temperatures and light conditions. Change the value in small steps to ensure you can continue to read the display.

4.11. Memory Test

Allows verification of the RAM, EEPROM, and Flash memory of the SITRANS LR200.

LCD Display	IDLE	No test in progress.
	BUSY	Test in progress.
	PASS	Memory test successful.
	FAIL	Test failed.
	Err1	Test returned unexpected results.
	P Oxcafe	Test passed with result data.
	F Oxcafe	Test failed with result data.
Handheld programmer entry	1 to 9	Any numeric key from 1 to 9 activates test.

- Press RIGHT arrow to edit then press any numeric key from 1 to 9 to activate the test.
- The reading will display BUS and then the test result text.

5. Communication

Note: Default settings in the parameter tables are indicated with an asterisk (*) unless explicitly stated.

5.1. Device Address

Sets the device address or poll ID on a HART network. Any address other than 0 will cause the output current to be a fixed value, and the current will not indicate the reading.

Values	Range: 0 to 15
	Default: 0

To reset Device Address via SIMATIC PDM:

- Open the project in **Process Device Network View** then right-click on the device.
- Go to **Object Properties > Connection** to access the field **Short Address**.

6. Security

Note: Default settings in the parameter tables are indicated with an asterisk (*) unless explicitly stated.

6.1. Remote Access

6.1.1. Access Control

Note: If access control is changed to limit remote access, it can only be reset via the handheld programmer.

Enables/disables the read/write access to parameters via remote communications.

Options		Read only	No changes are permitted via remote communications.
	*	Read Write	Changes are permitted.
		Restricted	Sets the status to Read only, with the potential for another HART device to change this parameter only, via remote communications.

6.2. Local Access

6.2.1. Write Protect

Note: This lock affects only the handheld programmer. A remote master can change configuration if **Access Control (6.1.1.)** is set to allow this.

Prevents any changes to parameters via the handheld programmer.

Options		Range: 0 to 99999	
	*	Unlock value (stored in PIN to Unlock (6.2.2.))	Lock Off
		Any other value	Lock On

- To turn Lock On, key in any value other than the Unlock Value stored in **PIN to Unlock (6.2.2.)**.
- To turn Lock Off, key in the Unlock Value stored in **PIN to Unlock (6.2.2.)**.

6.2.2. PIN to Unlock

Notes:

- Do not lose your Unlock Value: it cannot be displayed once **Write Protect (6.2.1.)** has been set to a different value.
- Valid only for operation via the handheld programmer.
- A reset to **Factory Defaults** will not restore the unlock value at time of shipping.

*Stores the value to be entered in **Write Protect (6.2.1.)** to unlock programming. If **Write Protect (6.2.1.)** is set to a different value **PIN to Unlock (6.2.2.)** does not display the Unlock value*

Handheld Programmer Values		Range: 0 to 99999
		Value when shipped: 1954. Not restored by a reset to Factory Defaults.
	----	Display when Lock is on

7. Language

Selects the language to be used on the LCD.

Options	*	English
		Deutsch
		Français
		Español

Appendix A: Alphabetical Parameter List

Note: Maintenance Parameters are not listed below. See *Remaining Device Lifetime* on page 97, *Remaining Sensor Lifetime* on page 100, *Service Schedule* on page 103, and *Calibration Schedule* on page 106 for those parameters.

Parameter Name (Parameter Number)	Page Number
Full Scale (20 mA Setpoint) (2.6.3.)	82
Start of Scale (4 mA Setpoint) (2.6.2.)	82
Access Control (6.1.1.)	111
Algorithm (2.8.4.1.)	88
Auto False Echo Suppression (2.8.7.1.)	92
Auto False Echo Suppression Range (2.8.7.2.)	93
CLEF Range (2.8.4.4.)	89
Confidence (2.8.6.1.)	91
Current Internal Temperature (3.2.1.)	96
Current Output Function (2.6.1.)	81
Damping Filter (2.2.4.)	77
Device Address (5.1.)	111
Dimension A (2.7.1.3.)	85
Dimension L (2.7.1.4.)	85
Distance Measurement (2.8.9.3.)	95
Echo Lock (2.8.5.1.)	90
Echo Profile (3.1.)	95
Echo Quality (2.8.6.)	91
Echo Strength (2.8.6.2.)	91
Echo Threshold (2.8.4.3.)	89
Empty rate (2.4.3.)	79
Far Range (2.8.2.)	87
Level (2.5.3.)	80
Fill Rate (2.4.2.)	79
Firmware Revision (2.1.2.)	76
Hardware Revision (2.1.1.)	76
High Calibration Pt. (2.3.2.)	78
Highest value (3.2.2.)	96
Hover Level (2.8.7.3.)	94
Language (7.)	112
LCD Contrast (4.10.)	110
LCD Fast Mode (4.9.)	110

Parameter Name (Parameter Number)	Page Number
Level Measurement (2.8.9.1.)	95
Loader Revision (2.1.3.)	76
Low Calibration Pt. (2.3.1.)	77
Lowest value (3.2.3.)	96
mA Output Value (2.6.6.)	83
Manufacture Date (4.6.)	109
Master Reset (4.1.)	96
Material (2.2.3.)	77
Material Level (2.5.1.)	80
Control Range; upper limit (Max. mA limit) (2.6.5.)	82
Maximum Volume (2.7.1.2.)	85
Memory Test (4.11.)	110
Control Range; lower limit (Min. mA limit) (2.6.4.)	82
Near Range (2.8.1.)	87
Sensor Mode (2.2.2.)	76
PIN to Unlock (6.2.2.)	112
Position Detect (2.8.4.2.)	88
Powered Hours (4.7.)	109
Power-on Resets (4.8.)	109
Propagation Factor (2.8.3.)	87
Response Rate (2.4.1.)	78
Sensor Offset (2.3.3.)	78
Space Measurement (2.8.9.2.)	95
Timer (2.5.2.)	80
Measured Values (2.8.9.)	95
Units (2.2.1.)	76
Vessel Shape (2.7.1.1.)	83
Volume 1 (2.7.2.2.)	86
Volume Measurement (2.8.9.4.)	95
Write Protect (6.2.1.)	112

Appendix B: Troubleshooting

Communication Troubleshooting





- 1) Check the following:
 - There is power at the instrument.
 - The LCD shows the relevant data.
 - The device can be programmed using the handheld programmer.
 - If any fault codes are being displayed see *General Fault Codes* on page 117 for a detailed list.
- 2) Verify that the wiring connections are correct.
- 3) See the table below for specific symptoms.

Symptom	Corrective action
The device cannot be programmed via the handheld programmer.	<ul style="list-style-type: none">• Ensure Write Protect (6.2.1) on page 112 is set to the unlock value.
You try to set a SITRANS LR200 parameter via remote communications but the parameter remains unchanged.	<ul style="list-style-type: none">• Ensure Write Protect (6.2.1) on page 112 is set to the unlock value, then try setting the parameter via the handheld programmer.• Ensure Access Control (6.1.1) on page 111 is set to Read/Write.• Some parameters can be changed only when the device is not scanning. Try pressing Mode  to put the device into PROGRAM mode.

If you continue to experience problems, go to our website at: www.siemens.com/LR200, and check the FAQs for SITRANS LR200, or contact your Siemens Milltronics representative.

Device Status Icons

Icon	Priority Level	Meaning
	1	<ul style="list-style-type: none"> Maintenance alarm Measurement values are not valid
	2	<ul style="list-style-type: none"> Maintenance warning: maintenance demanded immediately Measured signal still valid
	3	<ul style="list-style-type: none"> Maintenance required Measured signal still valid
	1	<ul style="list-style-type: none"> Process value has reached an alarm limit
	2	<ul style="list-style-type: none"> Process value has reached a warning limit
	3	<ul style="list-style-type: none"> Process value has reached a tolerance limit
	1	<ul style="list-style-type: none"> Configuration error Device will not work because one or more parameters/components is incorrectly configured
	2	<ul style="list-style-type: none"> Configuration warning Device can work but one or more parameters/components is incorrectly configured
	3	<ul style="list-style-type: none"> Configuration changed Device parameterization not consistent with parameterization in project. Look for info text.
	1	<ul style="list-style-type: none"> Manual operation (local override) Communication is good; device is in manual mode.
	2	<ul style="list-style-type: none"> Simulation or substitute value Communication is good; device is in simulation mode or works with substitute values.
	3	<ul style="list-style-type: none"> Out of operation Communication is good; device is out of action.



Icon	Priority Level	Meaning (cont'd)
		<ul style="list-style-type: none"> Data exchanged
		<ul style="list-style-type: none"> No data exchange
		<ul style="list-style-type: none"> Write access enabled
		<ul style="list-style-type: none"> Write access disabled











General Fault Codes

Notes:











- If more than one fault is present, the device status indicator and text for each fault alternate at 2 second intervals.
- Some faults cause the device to go to Fail-safe mode (Fault 52). These are indicated with an asterisk (*).

General Fault Codes





Code / Icon	Meaning	Corrective Action
S: 0 	* The device was unable to get a measurement within the Fail-safe LOE Timer period. Possible causes: faulty installation, antenna material buildup, foaming/other adverse process conditions, invalid configuration range.	<ul style="list-style-type: none"> Ensure installation details are correct. Ensure no antenna material buildup. Clean if necessary. Adjust process conditions to minimize foam or other adverse conditions. Correct configuration range. If fault persists, contact your local Siemens representative.
S: 2 	* Unable to collect profile because of a power condition that is outside the operating range of the device.	Repair required: contact your local Siemens representative.
S: 3 	Device is nearing its lifetime limit according to the value set in Maintenance Required Limit.	Replacement is recommended.

General Fault Codes (cont'd)		
Code / Icon	Meaning	Corrective Action
S: 4 	Device is nearing its lifetime limit according to the value set in Maintenance Demanded Limit.	Replacement is recommended.
S: 6 	Sensor is nearing its lifetime limit according to the value set in Maintenance Required Limit.	Replacement is recommended.
S: 7 	Sensor is nearing its lifetime limit according to the value set in Maintenance Demanded Limit.	Replacement is recommended.
S: 8 	Service interval as defined in Maintenance Required Limit has expired.	Perform service.
S: 9 	Service interval as defined in Maintenance Demanded Limit has expired.	Perform service.
S: 11 	Internal temperature sensor failure.	Repair required: contact your local Siemens representative.
S: 12 	Internal temperature of device has exceeded specifications: it is operating outside its temperature range.	<ul style="list-style-type: none"> • Relocate device and/or lower process temperature enough to cool device. • Inspect for heat-related damage and contact your local Siemens representative if repair is required. • Fault code will persist until a manual reset is performed using SIMATIC PEM or the LCD interface.
S: 17 	Calibration interval as defined in Maintenance Required Limit has expired.	Perform calibration.
S: 18 	Calibration interval as defined in Maintenance Demanded Limit has expired.	Perform calibration.
S: 28 	* Internal device failure caused by a RAM memory error.	Repair required: contact your local Siemens representative.

General Fault Codes (cont'd)





Code / Icon	Meaning	Corrective Action
S: 29 	* EEPROM damaged.	Repair required: contact your local Siemens representative.
S: 31 	* Flash error.	Repair required: contact your local Siemens representative.
S: 33 	* Factory calibration for the internal temperature sensor has been lost.	Repair required: contact your local Siemens representative.
S: 34 	* Factory calibration for the device has been lost.	Repair required: contact your local Siemens representative.
S: 35 	* Factory calibration for the device has been lost.	Repair required: contact your local Siemens representative.
S: 36 	* Unable to start microwave module.	Cycle power. If fault persists, contact your local Siemens representative.
S: 37 	* Measurement hardware problem.	Cycle power. If fault persists, contact your local Siemens representative.
S: 38 	* Failure in the device electronics.	Cycle power. If fault persists, contact your local Siemens representative: repair required.
S: 43 	* Factory calibration for the radar receiver has been lost.	Repair required: contact your local Siemens representative.
S: 45 	* No valid boot program detected: firmware corrupt.	Repair required: contact your local Siemens representative.
S: 48 	* User configuration is invalid. One or more of parameters: Low Calibration Point, High Calibration Point, Volume breakpoints, and/or Auto False-Echo Suppression, are set to invalid values.	<ul style="list-style-type: none"> • Reconfigure the unit. • Ensure the difference between High Calibration Point and Low Calibration Point is not less than or equal to zero; do a Master Reset.

General Fault Codes (cont'd)

Code / Icon	Meaning	Corrective Action
S: 49 	* EEPROM corrupt.	Repair required: contact your local Siemens representative.
S: 50 	* EEPROM corrupt.	Repair required: contact your local Siemens representative.
S: 51 	* EEPROM corrupt.	Repair required: contact your local Siemens representative.
S: 52 	Fail-safe is activated. Possible causes: 1) hardware failure 2) memory failure 3) Fail-safe LOE timer expired– possible causes: faulty installation, antenna material buildup, foaming/other adverse process conditions, invalid calibration range.	For 3): <ul style="list-style-type: none"> • Correct configuration; ensure installation is correct; • no antenna buildup; • adjust process conditions to minimize foaming/other adverse conditions; • correct calibration range. If fault persists, or for 1) and 2), contact your local Siemens representative.
S: 53 	* Configuration lost: one or more parameter settings have been lost. This may occur after a firmware upgrade causes user parameters to be reset.	Restore user parameters using SIMATIC PDM.

Operation Troubleshooting

Operating symptoms, probable causes, and resolutions.

Operation Troubleshooting		
Symptom	Cause	Action
Display shows  S: 0 LOE	level or target is out of range	<ul style="list-style-type: none"> check specifications check Low Calibration Pt. (2.3.1.) increase Confidence (2.8.6.1.)
Display shows  S: 0 LOE	material build-up on antenna	<ul style="list-style-type: none"> clean the antenna re-locate SITRANS LR200
Display shows  S: 0 LOE	location or aiming: <ul style="list-style-type: none"> poor installation flange not level Auto False Echo Suppression may be incorrectly applied 	<ul style="list-style-type: none"> check to ensure nozzle is vertical ensure end of antenna protrudes from end of nozzle review <i>Auto False Echo Suppression (2.8.7.1.)</i> on page 128 ensure Auto False Echo Suppression Range is set correctly
Display shows  S: 0 LOE	antenna malfunction: <ul style="list-style-type: none"> temperature too high physical damage excessive foam multiple echoes 	<ul style="list-style-type: none"> check Current Internal Temperature (3.2.1.) use foam deflector or stillpipe relocate use a defoamer set Algorithm (2.8.4.1.) to F (First echo)
Reading does not change, but the level does	SITRANS LR200 processing wrong echo, for example, vessel wall, or structural member	<ul style="list-style-type: none"> re-locate SITRANS LR200 check nozzle for internal burrs or welds rotate instrument 90° use Auto False Echo Suppression (2.8.7.1.) if necessary: see <i>Auto False Echo Suppression (2.8.7.1.)</i> on page 128
Measurement is consistently off by a constant amount	<ul style="list-style-type: none"> setting for Low Calibration Pt. (2.3.1.) not correct setting for Sensor Offset (2.3.3.) not correct 	<ul style="list-style-type: none"> check distance from sensor reference point to Low Calibration Pt. (2.3.1.) check Sensor Offset (2.3.3.)
Screen blank	power error	<ul style="list-style-type: none"> check nameplate rating against voltage supply check power wiring or source
	too much load resistance	<ul style="list-style-type: none"> change barrier type, or remove something from the loop, or increase supply voltage

Operation Troubleshooting (cont'd)		
Symptom	Cause	Action
Reading erratic	echo confidence weak	<ul style="list-style-type: none"> refer to Confidence (2.8.6.1) use Auto False Echo Suppression (2.8.7.1) and Auto False Echo Suppression Range (2.8.7.2) use foam deflector or stillpipe
	liquid surface vortexed	<ul style="list-style-type: none"> decrease Fill Rate (2.4.2) relocate instrument to side pipe increase confidence threshold in Echo Threshold (2.8.4.3)
	material filling	<ul style="list-style-type: none"> re-locate SITRANS LR200
Reading response slow	Fill Rate (2.4.2) setting incorrect	<ul style="list-style-type: none"> increase measurement response if possible
Reads correctly but occasionally reads high when vessel is not full	<ul style="list-style-type: none"> detecting close range echo build up near top of vessel or nozzle nozzle problem 	<ul style="list-style-type: none"> clean the antenna use Auto False Echo Suppression (2.8.7.1) and Auto False Echo Suppression Range (2.8.7.2)
Level reading lower than actual material level	<ul style="list-style-type: none"> material is within Near Range zone multiple echoes processed 	<ul style="list-style-type: none"> decrease Near Range (2.8.1) (minimum value depends on antenna type) raise SITRANS LR200 ensure Algorithm (2.8.4.1) is set to F (First echo)
	<ul style="list-style-type: none"> vessel near empty and low dK material 	<ul style="list-style-type: none"> ensure Material (2.2.3) selection is LIQUID LOW DK set Position Detect (2.8.4.2) to Hybrid set CLEF Range (2.8.4.4) to 0.5 m

Appendix C: Maintenance

SITRANS LR200 requires no maintenance or cleaning under normal operating conditions.

Under severe operating conditions, the horn antenna may require periodic cleaning. If cleaning becomes necessary:

- Note the antenna material and the process medium, and select a cleaning solution that will not react adversely with either.
- Remove the instrument from service and wipe the antenna clean using a cloth and suitable cleaning solution.

Unit Repair and Excluded Liability

All changes and repairs must be done by qualified personnel, and applicable safety regulations must be followed. Please note the following:

- The user is responsible for all changes and repairs made to the device.
- All new components must be provided by Siemens Milltronics Process Instruments Inc.
- Restrict repair to faulty components only.
- Do not re-use faulty components.

Replacing the antenna

- When a new antenna is installed the propagation factor will not change.
- After replacing the antenna check the material level reported by the device against the actual material level, and if necessary use **Sensor Offset (2.3.3.)** on page 78 to compensate.

Appendix D: Technical Reference

Note: Where a number follows the parameter name (for example, Algorithm (2.8.4.1.) this is the parameter access number via the handheld programmer. See **Parameter Reference** on page 75 for a complete list of parameters.

Principles of Operation

SITRANS LR200 is a 2-wire 6 GHz pulse radar level transmitter for continuous monitoring of liquids and slurries¹⁾. Radar level measurement uses the time of flight principle to determine distance to a material surface. The device transmits a signal and waits for the return echo. The transit time is directly proportional to the distance from the material.

Pulse radar uses polarized electromagnetic waves. Microwave pulses are emitted from the antenna at a fixed repetition rate, and reflect off the interface between two materials with different dielectric constants (the atmosphere and the material being monitored).

Electromagnetic wave propagation is virtually unaffected by temperature or pressure changes, or by changes in the vapor levels inside a vessel. Electromagnetic waves are not attenuated by dust.

SITRANS LR200 consists of an enclosed electronic circuit coupled to an antenna and process connection. The electronic circuit generates a radar signal (6.3 GHz in North America, 5.8 GHz elsewhere) that is directed to the antenna.

The signal is emitted from the antenna, and the reflected echoes are digitally converted to an echo profile. The profile is analyzed to determine the distance from the material surface to the sensor reference point²⁾. This distance is used as a basis for the display of material level and mA output.

Echo Processing

Process Intelligence

The signal processing technology embedded in Siemens radar level devices is known as **Process Intelligence**.

Process intelligence provides high measurement reliability regardless of the dynamically changing conditions within the vessel being monitored. The embedded Process Intelligence dynamically adjusts to the constantly changing material surfaces within these vessels.

¹⁾ The microwave output level is significantly less than that emitted from cellular phones.

²⁾ See **Dimensions: Uni-Construction Polypropylene Rod Antenna** on page 12 or **Appendix G: Flange Adapter Versions** on page 152.

Process Intelligence is able to differentiate between the true microwave reflections from the surface of the material and unwanted reflections being returned from obstructions such as seam welds or supports within a vessel. The result is repeatable, fast and reliable measurement. This technology was developed as result of field data gained over some twenty years from more than 1,000,000 installations in many industries around the world.

Higher order mathematical techniques and algorithms are used to provide intelligent processing of microwave reflection profiles. This “knowledge based” technique produces superior performance and reliability.

Echo Selection

Time Varying Threshold (TVT)

A Time Varying Threshold (TVT) hovers above the echo profile to screen out unwanted reflections (false echoes).

In most cases the material echo is the only one which rises above the default TVT.

In a vessel with obstructions, a false echo may occur. See **Auto False Echo Suppression (2.8.7.1.)** on page 128 for more details.

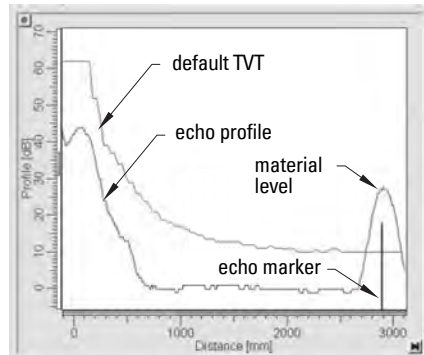

The device characterizes all echoes that rise above the TVT as potential good echoes. Each peak is assigned a rating based on its strength, area, height above the TVT, and reliability, amongst other characteristics.

Algorithm (2.8.4.1.)

The true echo is selected based on the setting for the Echo selection algorithm. Options are **true First Echo**, **Largest Echo**, or **best of First and Largest**.

Position Detect (2.8.4.2.)

The echo position detection algorithm determines which point on the echo will be used to calculate the precise time of flight, and calculates the range using the calibrated propagation velocity (see **Propagation Factor (2.8.3.)** for values). There are three options:

- **Center**
- **Hybrid**
- **CLEF** (Constrained Leading Edge Fit)

Center

Uses center of the echo.

Hybrid

Uses the Center algorithm for the top part of the vessel, and the CLEF algorithm for the part nearest the vessel bottom, according to the setting for **CLEF range**.

CLEF (Constrained Leading Edge Fit)

- Uses the leading edge of the echo.
- Is used mainly to process the echo from materials with a low dK value.

In an almost empty flat-bottomed vessel, a low dK material may reflect an echo weaker than the echo from the vessel bottom. The echo profile shows these echoes merging. The device may then report a material level equal to or lower than empty

The CLEF algorithm enables the device to report the level correctly.

Example: CLEF off: Position set to Hybrid

Vessel height: 1.5 m; CLEF range set to 0 (**Center** algorithm gives the same result.)

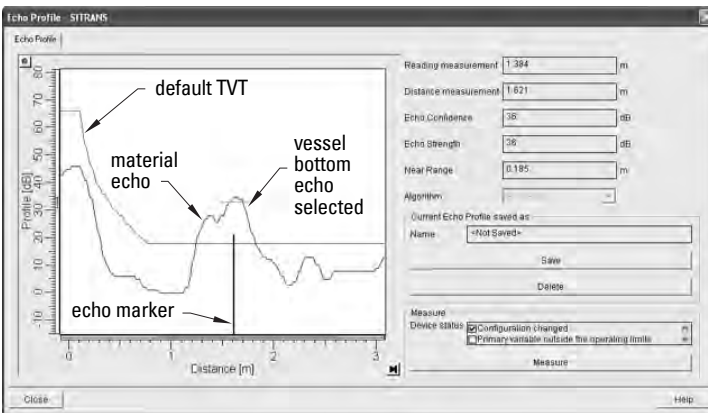

Example: CLEF enabled

Vessel height: 1.5 m; CLEF range set to 0.5 m

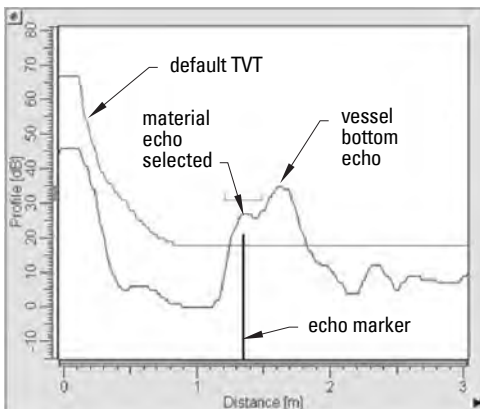

CLEF Range (2.8.4.4.)

CLEF Range is referenced from Low Calibration Point (process empty level). When the **Hybrid** algorithm is selected in **Position Detect (2.8.4.2.)**, the CLEF algorithm will be applied up to the limit of CLEF Range. Above this limit the Center algorithm will be applied.

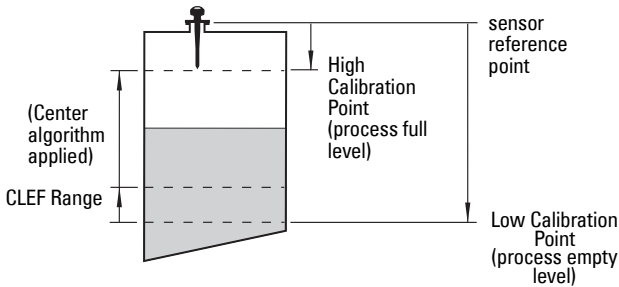

Echo Threshold (2.8.4.3.)

Confidence (2.8.6.1.) describes the quality of an echo. Higher values represent higher quality. **Echo Threshold** defines the minimum confidence value required for an echo to be accepted as valid and evaluated.

Echo Lock (2.8.5.1.)

If the echo selected by **Algorithm** is within the Echo Lock window, the window is centered about the echo, which is used to derive the measurement. In radar applications, two measurement verification options are used:

Lock Off

SITRANS LR200 responds immediately to a new selected echo (within the restrictions set by the Maximum Fill / Empty Rate), but measurement reliability is affected.

Material Agitator

A new measurement outside the Echo Lock Window must meet the sampling criteria before the window will move to include it.

The other available options, **Maximum Verification** and **Total Lock** are not recommended for radar.

Auto False Echo Suppression (2.8.7.1.)

Notes:

- For detailed instructions on using this feature via PDM see **Auto False Echo Suppression** on page 48.
- For detailed instructions on using this feature via the handheld programmer see **Auto False Echo Suppression (2.8.7.1.)** on page 92.

Auto False Echo Suppression is designed to learn a specific environment (for example, a particular vessel with known obstructions), and in conjunction with Auto False Echo Suppression Range to remove false echoes appearing in front of the material echo.

The material level should be below all known obstructions at the moment when Auto False Echo Suppression learns the echo profile. Ideally the vessel should be empty or almost empty, and if an agitator is present, it should be running.

The device learns the echo profile over the whole measurement range and the TVT is shaped around all echoes present at that moment.

Auto False Echo Suppression Range (2.8.7.2.)

Auto False Echo Suppression Range specifies the range within which the learned TVT is applied. Default TVT is applied over the remainder of the range.

The learned TVT screens out the false echoes caused by obstructions. The default TVT allows the material echo to rise above it.

Auto False Echo Suppression Range must be set to a distance shorter than the distance to the material level when the environment was learned, to avoid the material echo being screened out.

Example before Auto False Echo Suppression

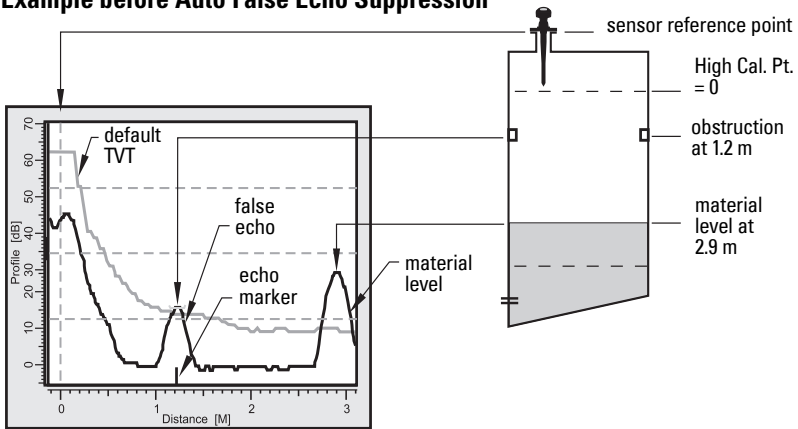

Example after Auto False Echo Suppression

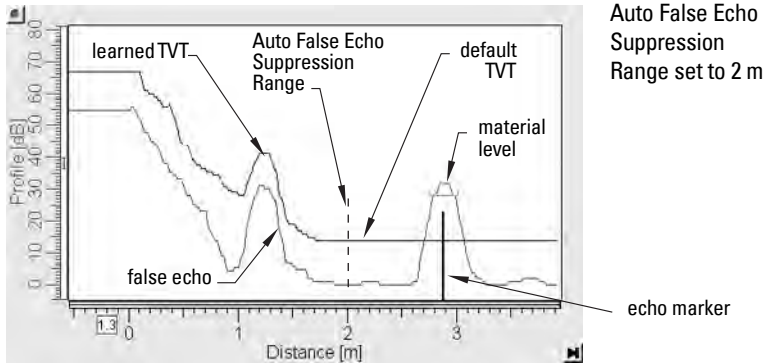

Auto False Echo
Suppression
Range set to 2 m

Measurement Range

Near Range (2.8.1.)

Near Range programs SITRANS LR200 to ignore the zone in front of the antenna. The default setting is 0.3 m (1 ft), plus any shield length, from the sensor reference point¹⁾.

Near Range allows you to increase the value from its factory default but Auto False Echo Suppression (2.8.7.1.) is generally recommended in preference to this.

Far Range (2.8.2.)

Far Range can be used in applications where the base of the vessel is conical or parabolic. A reliable echo may be available below the vessel empty distance, due to an indirect reflection path.

Increasing Far Range to 30% or 40% can provide stable empty vessel readings.

Measurement Response

Note: Units are defined in **Units (2.2.1.)** and are in meters by default.

Response Rate (2.4.1.) limits the maximum rate at which the display and output respond to changes in the measurement. There are three preset options: slow, medium, and fast.

Once the real process fill/empty rate (m/s by default) is established, a response rate can be selected that is slightly higher than the application rate. Response Rate automatically adjusts the filters that affect the output response rate.

Response Rate (2.4.1.)	Fill Rate (2.4.2.)/ Empty rate (2.4.3.)	Damping Filter (2.2.4.)
* Slow	0.1 m/min (0.32 ft/min)	10 s
Medium	1.0 m/min (3.28 ft/min)	
Fast	10.0 m/min (32.8 ft/min)	

¹⁾ For the reference point for each configuration, see **Dimensions: Uni-Construction Polypropylene Rod Antenna** on page 12 for the standard version, or *Appendix G: Flange Adapter Versions*, page 152 onwards.

Damping

Damping Filter (2.2.4.) smooths out the response to a sudden change in level. This is an exponential filter and the engineering unit is always in seconds.

In 5 time constants the output rises exponentially: from 63.2% of the change in the first time constant, to almost 100% of the change by the end of the 5th time constant.

Damping example

time constant = 2 seconds

input (level) change = 2 m

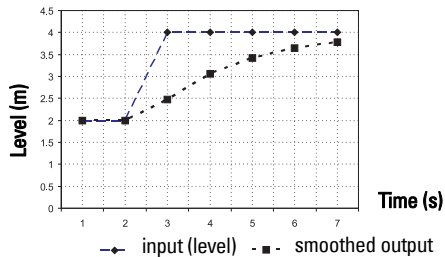

Analog Output

The mA Output (current output) is proportional to material level in the range 4 to 20 mA. 0% and 100% are percentages of the full-scale reading (m, cm, mm, ft, in). Typically mA output is set so that 4 mA equals 0% and 20 mA equals 100%.

When SITRANS LR200 is put into **PROGRAM** mode (for example, by navigating through the menu) it stops updating the output of the device (local user interface and mA Output). It stores the most recent measurement, and holds the associated readings and mA signal output. The device reverts to the parameter last addressed during the previous program session.

When the device is returned to **Measurement** mode, the transceiver resumes operation. The reading and mA output default to the last measurement taken. The reading and associated outputs migrate to the current process level at a rate controlled by Response Rate (2.4.1.).

If the device is left in **PROGRAM** mode for 10 minutes without input, it automatically reverts to **Measurement** mode.

Two parameters affect the mA output: **Operating Mode** and **Current Output Function**.

Sensor Mode

This parameter controls the input. Depending on the reference point used, the mA output reflects either Level, Space, or Distance. By default Sensor Mode is set to **Level**.

Operation	Description	Reference point
NO SERVICE	Measurement and associated loop current not being updated. Device defaults to Fail-safe mode ^{a)} .	
LEVEL	Distance to material surface	Low Calibration Point (process empty level)
SPACE		High Calibration Point (process full level)
DISTANCE		Sensor Reference Point

a) See **Fail-safe Mode** on page 132.

You also have the option to put the device out of service, in which case the device defaults to Fail-safe mode, and the reported level depends on the device type. A standard device reports the last valid reading, and a NAMUR NE 43-compliant device reports the user-defined value for Material Level (3.58 mA by default).

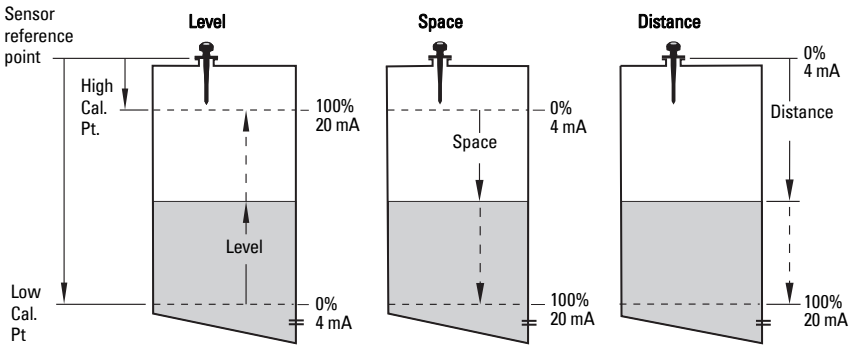

Current Output Function

Current Output Function (2.6.1.) controls the output and applies any relevant scaling. By default it is set to **Level**. Other options are Space, Distance, and Volume. (The device can carry out a volume calculation only after a vessel shape has been specified.)

When a volume application type is chosen, Sensor Mode remains as **Level** and the mA Output is automatically converted to **Volume**.

To view the mA reading in the secondary region of the LCD, press **5** on the handheld programmer

Loss of Echo (LOE)

A loss of echo (LOE) occurs when the calculated measurement is judged to be unreliable because the echo confidence value has dropped below the echo confidence threshold.

Confidence (2.8.6.1.) describes the quality of an echo. Higher values represent higher quality.

Echo Threshold (2.8.4.3.) defines the minimum confidence value required for an echo to be accepted as valid and evaluated.

If the LOE condition persists beyond the time limit set in Timer (2.5.2.) the LCD displays the Service Required icon, and the text region displays the fault code **S: 0** and the text LOE.

If two faults are present at the same time, the fault code, error text, and error icon for each fault are displayed alternately. For example, Loss of Echo and Fail-safe.



S: 0 LOE



S: 52 Fail-safe

Fail-safe Mode

The purpose of the Fail-safe setting is to put the process into a safe mode of operation in the event of a fault or failure. The value to be reported in the event of a fault is selected so that a loss of power or loss of signal triggers the same response as an unsafe level.

Timer (2.5.2.) determines the length of time a Loss of Echo (LOE) condition will persist before a Fail-safe state is activated. The default setting is 10 seconds.

Material Level (2.5.1.) determines the material level to be reported when **Timer (2.5.2.)** expires, depending on the device type (standard or NAMUR NE 43-compliant.)

STANDARD DEVICE			
Options		HI	20.5 mA (max. mA Limit)
		LO	3.8 mA (min. mA Limit)
	*	HOLD	Last valid reading
		VALUE	User-selected value defined in Level (2.5.3.)

NAMUR NE 43-COMPLIANT DEVICE			
Options		HI	20.5 mA (max. mA Limit)
		LO	3.8 mA (min. mA Limit)
		HOLD	Last valid reading
	*	VALUE	User-selected value Level (2.5.3.) , default 3.58 mA

Upon receiving a reliable echo, the loss of echo condition is aborted, the Service Required icon and error message are cleared, and the reading and mA output return to the current material level.

Maximum Process Temperature Chart



WARNING: Internal temperature must not exceed 80 °C (176 °F).

Notes:

- The chart below is for guidance only.
- The chart does not represent every possible process connection arrangement. For example, it will NOT apply if you are mounting SITRANS LR200 directly on a metallic vessel surface.
- The chart does not take into consideration heating from direct sunshine exposure.

Maximum Process Temperature versus allowable ambient

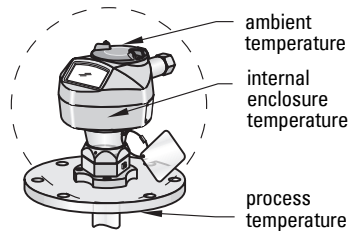
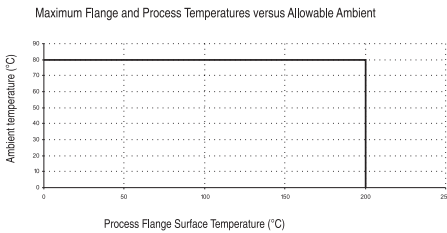

Where the chart does not apply, please use your own judgement regarding the use of SITRANS LR200.

See **Current Internal Temperature (3.2.1.)** on page 96 to monitor the Internal Temperature.

If the internal temperature exceeds the maximum allowable limit, a sun shield or a longer nozzle may be required.

Process Pressure/Temperature derating curves



WARNINGS:

- **Never attempt to loosen, remove or disassemble process connection or instrument housing while vessel contents are under pressure.**
- **Materials of construction are chosen based on their chemical compatibility (or inertness) for general purposes. For exposure to specific environments, check with chemical compatibility charts before installing.**
- **The user is responsible for the selection of bolting and gasket materials which will fall within the limits of the flange and its intended use and which are suitable for the service conditions.**
- **Improper installation may result in loss of process pressure and/or release of process fluids and/or gases.**

Notes:

- The Process Device Tag shall remain with the process pressure boundary assembly¹⁾. In the event the instrument package is replaced, the Process Device Tag shall be transferred to the replacement unit.
- SITRANS LR200 units are hydrostatically tested, meeting or exceeding the requirements of the ASME Boiler and Pressure Vessel Code and the European Pressure Equipment Directive.
- The serial numbers stamped in each process connection body, (flange, threaded, or sanitary), provide a unique identification number indicating date of manufacture. Example: MMDDYY – XXX (where MM = month, DD = day, YY = year, and XXX= sequential unit produced)
Further markings (space permitting) indicate flange configuration, size, pressure class, material, and material heat code.

Pressure Equipment Directive, PED, 97/23/EC

Siemens Level Transmitters with flanged, threaded, or sanitary clamp type process mounts have no pressure-bearing housing of their own and, therefore, do not come under the Pressure Equipment Directive as pressure or safety accessories, (see EU Commission Guideline 1/8).

¹⁾ The process pressure boundary assembly comprises the components that act as a barrier against pressure loss from the process vessel: that is, the combination of process connection body and emitter, but normally excluding the electrical enclosure.

! WARNING: Never attempt to loosen, remove or disassemble process connection or instrument housing while vessel contents are under pressure.

Notes:

- Customer to provide adequate bolting and gasketing to retain vessel pressure and provide sufficient sealing.
- UHMW-PE antennas are rated to a maximum of 80°C (176°F) of continuous duty, however, they can be used for periods of up to 3 hours at temperatures up to 120°C (248°F) at 1 bar pressure.

PTFE Rod Antenna ASME Hole Pattern, 150 lb

Flat-Face Flange (constant flange thickness series)

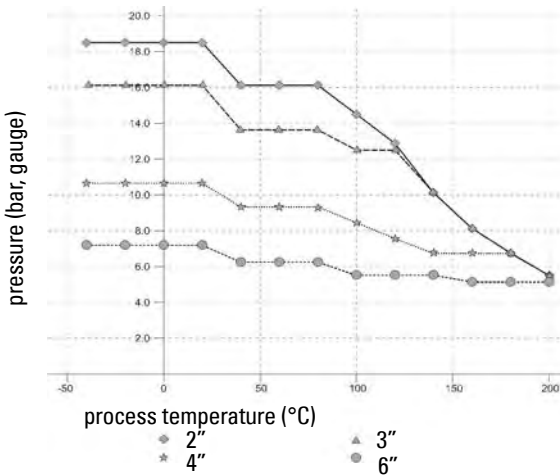

PTFE Rod Antenna, DN Hole Pattern, PN16

Flat-Face Flange (constant thickness series)

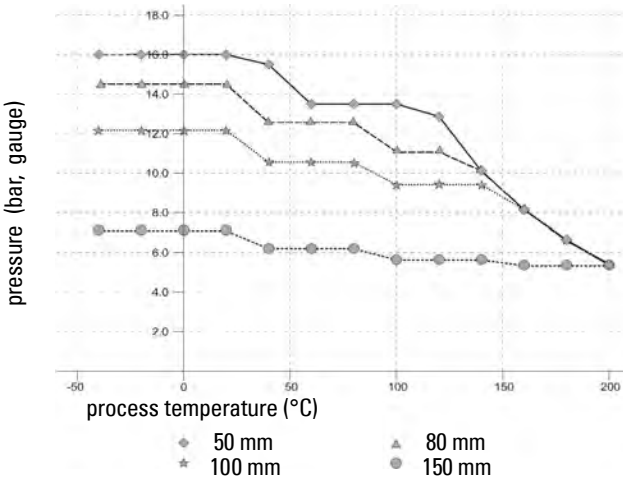

! WARNING: Never attempt to loosen, remove or disassemble process connection or instrument housing while vessel contents are under pressure.

Note: UHMW-PE antennas are rated to a maximum of 80°C (176°F) of continuous duty, however, they can be used for periods of up to 3 hours at temperatures up to 120°C (248°F) at 1 bar pressure.

PTFE Rod Antenna Threaded Connection

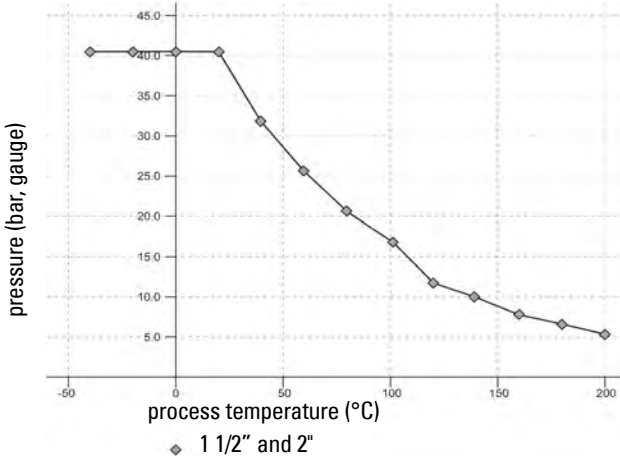

PTFE Rod Antenna Sanitary Connection

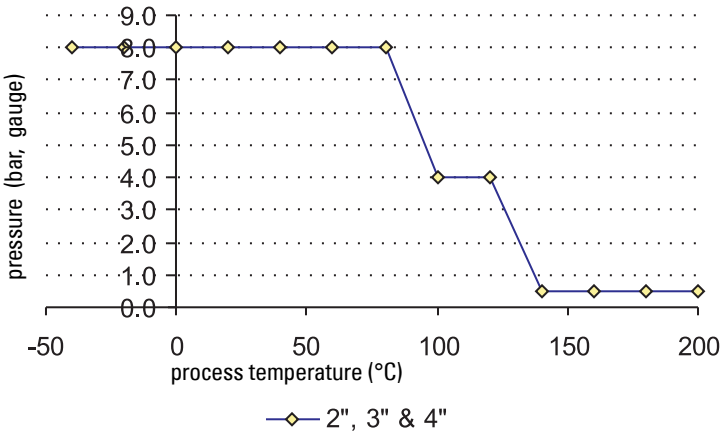

D: Technical Reference

! WARNING: Never attempt to loosen, remove or disassemble process connection or instrument housing while vessel contents are under pressure.

Notes:

- Customer to provide adequate bolting and gasketing to retain vessel pressure and provide sufficient sealing.
- UHMW-PE antennas are rated to a maximum of 80°C (176°F) of continuous duty, however, they can be used for periods of up to 3 hours at temperatures up to 120°C (248°F) at 1 bar pressure.

Horn Antenna or Waveguide, ASME Hole Pattern, 150 lb Flat-Face Flange (constant flange thickness series)

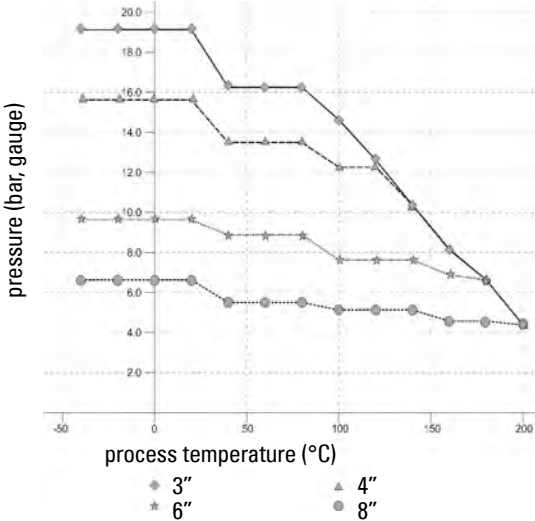

Horn Antenna or Wave Guide DN Hole Pattern, PN16 Flat-Face Flange (constant flange thickness series)

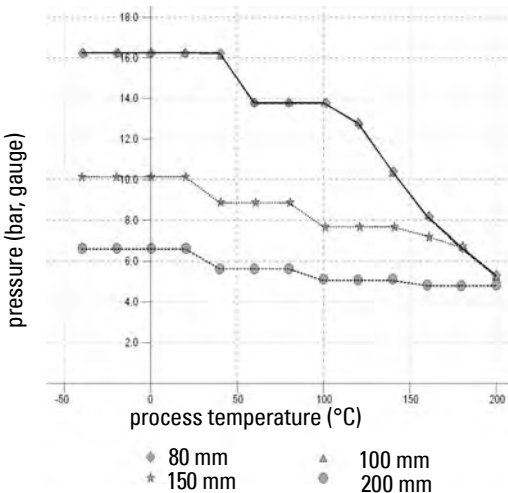

! WARNING: Never attempt to loosen, remove or disassemble process connection or instrument housing while vessel contents are under pressure.

Notes:

- Customer to provide adequate bolting and gasketing to retain vessel pressure and provide sufficient sealing.
- UHMW-PE antennas are rated to a maximum of 80°C (176°F) of continuous duty, however, they can be used for periods of up to 3 hours at temperatures up to 120°C (248°F) at 1 bar pressure.

**PTFE Rod Antenna, DN Hole Pattern, PN16, PN40
Raised Face Flange per EN 1092-1**

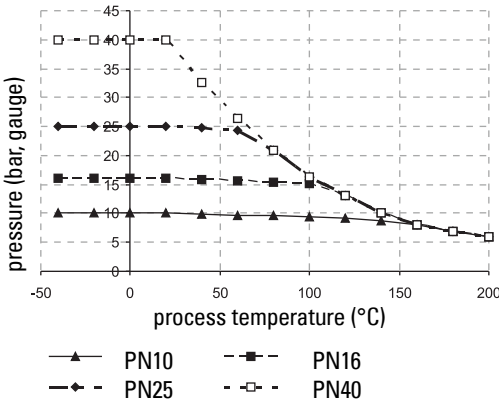

**Horn Antenna or Waveguide, DN Hole Pattern, PN16, PN40
Raised Face Flange per EN 1092-1**

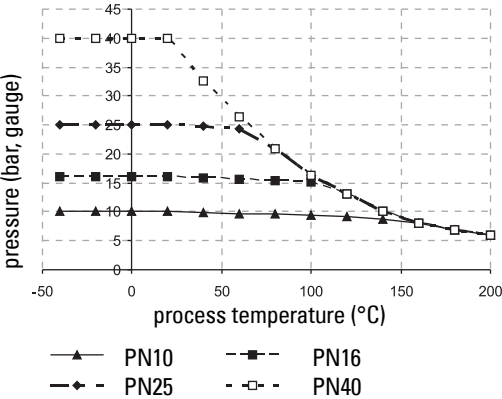

D: Technical Reference

Startup Behavior

- The device draws less than 3.6 mA at startup.
- Time to first measurement is less than 50 seconds

Loop power

Typical Connection Drawing

Note: Loop voltage is the voltage at the terminals of the power supply (not the voltage at the terminals of the device).

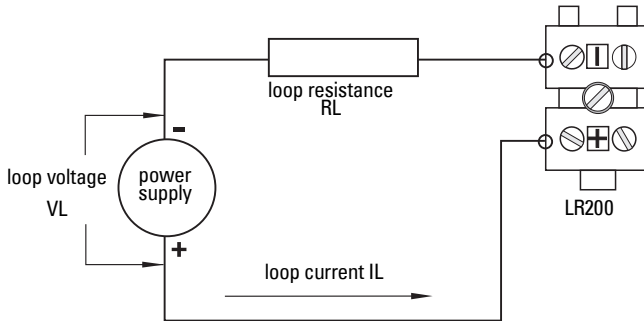

Allowable operating area of SITRANS LR200

Loop Voltage versus Loop Resistance

Curve 1 (General Purpose, Intrinsically Safe, Non-Sparking, Non-incendive)

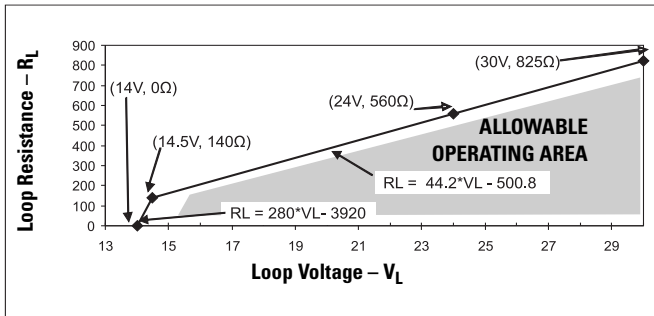

Curve 2 (Flameproof, Increased Safety, Explosion-proof)

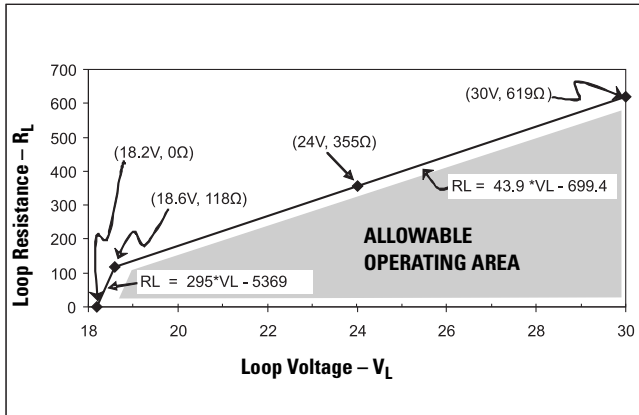

Appendix E: Application Examples

Note: In the applications illustrated below, values are for example purposes only.

You can use these examples as setup references. Enter the values in the parameter tables to select the corresponding functions.

Configure the basic settings using the Quick Start wizard parameters. (These parameters are inter-related, and changes take effect only after you select **YES** to apply changes in the last step.)

In each example, after performing a Quick Start, navigate to the other required parameters either via the handheld programmer, or using a Device Management tool (SIMATIC PDM or AMS Device Manager) and enter the appropriate values.

Liquid resin in storage vessel, level measurement

Notes:

- Minimum distance from flange face to target is limited by **Near Range (2.8.1)**.
- We recommend using Auto False Echo Suppression with an empty or almost empty vessel.

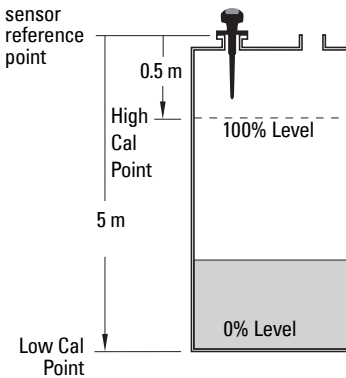

To obtain level measurement/4 to 20 mA output proportional to resin levels:

Low Calibration Pt. = 5 m (16.5 ft) from sensor reference point

High Calibration Pt. = 0.5 m (1.64 ft) from sensor reference point

Max. fill/empty rate = 0.2 m/min (0.65 ft/min)

In the event of a loss of echo:

SITRANS LR200 is to go into Fail-safe High after 2 minutes.

NOTE: Table continues on next page.

Parameter type	Parameter No. /Name	Options/Values	Function
Quick Start Wizard parameters	Material (1.2.)	LIQUID	
	Response Rate (1.3.)	MED	Medium =1 m/minute
	Units (1.4.)	M	meters
	Operating Mode (1.5.)	LEVEL	Level
	Low Calibration Point (1.6.)	5	5 m (16.5 ft)
	High Calibration Point (1.7.)	0.5	0.5 m (1.64 ft)
	Apply? (Apply changes) (1.8.)	YES	Transfers Quick Start settings to device.

Parameter type	Parameter No. /Name	Options/Values	Function (cont'd)
Independent parameters	Timer (2.5.2.)	2	2 minutes
	Material Level (2.5.1.)	HI	Fail-safe level set to High
	Auto False Echo Suppression Range (2.8.7.2.)	Distance ^{a)} minus 0.42 m (1.37 ft)	Sets length of learned TVT ^{b)} to use
	Auto False Echo Suppression (2.8.7.1.)	LEARN	Enables the use of learned TVT

- a) Distance to product from sensor reference point.
b) For more details see **Auto False Echo Suppression Range (2.8.7.2.)** on page 93 and **Auto False Echo Suppression (2.8.7.1.)** on page 92.

Return to **Measurement**: press **Mode**  to start normal operation.

Horizontal vessel with volume measurement

Notes:

- Minimum distance from flange face to target is limited by **Near Range (2.8.1.)**.
- We recommend using Auto False Echo Suppression with an empty or almost empty vessel.

To obtain level measurement/4 to 20 mA output proportional to vessel volume in a chemical vessel:

Low Calibration Point = 3.5 m (11.48 ft) from sensor reference point

High Calibration Point = 0.5 m (1.64 ft) from sensor reference point

Max. fill/empty rate = 0.2 m/min (0.65 ft/min)

Select vessel shape, Parabolic Ends, and enter values for A and L, to obtain a volume reading instead of level.

In the event of a loss of echo: SITRANS LR200 is to go into Fail-safe High after 2 minutes.

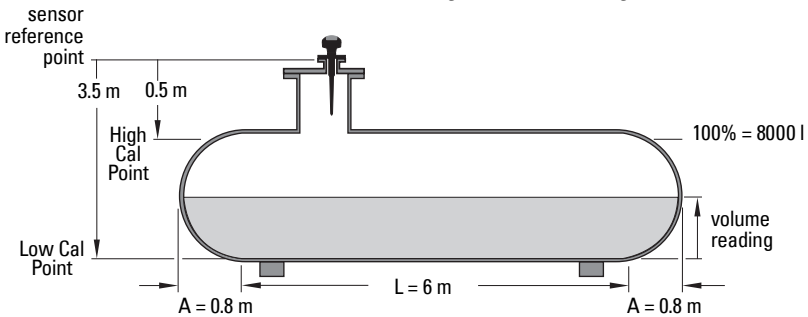

Parameter type	Parameter No./Name	Options/Values	Function
Quick Start Wizard parameters	Material (1.2.)	LIQUID	
	Response Rate (1.3.)	MED	Medium =1 m/minute
	Units (1.4.)	M	meters
	Operating Mode (1.5.)	LEVEL	Level is reported as Volume when a vessel shape is selected.
	Low Calibration Point (1.6.)	3.5	3.5 m (11.48 ft)
	High Calibration Point (1.7.)	0.5	0.5 m (1.64 ft)
	Apply? (Apply changes) (1.8.)	YES	Transfers Quick Start settings to device.
Independent parameters	Vessel Shape (2.7.1.1.)	PARABOLIC ENDS	Defines vessel shape.
	Maximum Volume (2.7.1.2.)	8000	8000 liters
	Dimension A (2.7.1.3.)	0.8	0.8 m (2.62 ft)
	Dimension L (2.7.1.4.)	6	6 m (19.68 ft)
	Timer (2.5.2.)	2	2 minutes
	Material Level (2.5.1.)	HI	Fail-safe level set to High
	Auto False Echo Suppression Range (2.8.7.2.)	[Distance ^{a)} minus 0.42 m]	Sets length of learned TVT curve ^{b)} to use
	Auto False Echo Suppression (2.8.7.1.)	LEARN	Enables the use of learned TVT curve ^{b)} .

a) Distance to product from sensor reference point.

b) For more details see **Auto False Echo Suppression Range (2.8.7.2.)** on page 93 and **Auto False Echo Suppression (2.8.7.1.)** on page 92.

Return to **Measurement**: press **Mode**  to start normal operation.

Sliding Waveguide on Anaerobic Digesters

Notes:

- Minimum distance from the flange face to the target is limited by **Near Range (2.8.1.)**.
- We recommend adjusting Auto False Echo Suppression parameters with an empty or almost empty vessel.

This application is to obtain a level measurement and corresponding 4 to 20 mA output proportional to the sludge level on a digester.

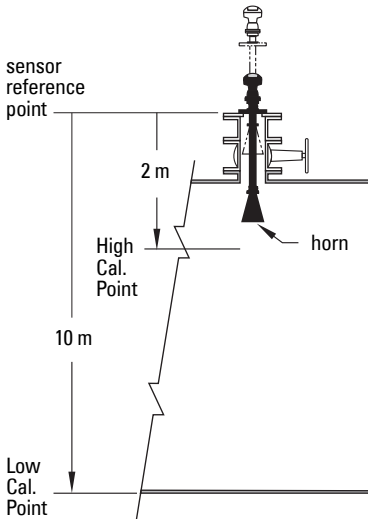

- The raised position is for installation and maintenance.
- The lowered position is for operation.
- Program the instrument for operation in the lowered position.
- Low Cal. Pt. is the bottom of the digester (10 m/33 ft from sensor reference point when the instrument is lowered to its normal operating position).
- High Cal.Pt. is 2 m (6.56 ft) from sensor reference point.
- The maximum rate of filling or emptying is about 0.1 m (4")/min.

Parameter type	Parameter Name (number)	Value	Function
Quick start wizard parameters	Material (1.2.)	LIQUID	
	Response Rate (1.3.)	MED	1 m/min. (3.28 ft/min.)
	Units (1.4.)	M	meters
	Operating Mode (1.5.)	LEVEL	Level
	Low Calibration Point (1.6.)	10	10 m/33 ft)
	High Calibration Point (1.7.)	2	2 m (6.56 ft)
	Apply? (Apply changes) (1.8.)	YES	
Independent parameters	Timer (2.5.2.)	2	2 minutes
	Material Level (2.5.1.)	HI	Hi

Parameter type	Parameter Name (number)	Value	Function (cont'd)
Independent parameters (cont'd)	Auto False Echo Suppression Range (2.8.7.2.)	[Distance ^{a)} minus 0.42 m]	Sets length of learned TVT curve ^{b)} to use
	Auto False Echo Suppression (2.8.7.1.)	LEARN	Enables the use of learned TVT curve ^{b)} .

- a) Distance to product from sensor reference point.
- b) For more details see **Auto False Echo Suppression Range (2.8.7.2.)** on page 93 and **Auto False Echo Suppression (2.8.7.1.)** on page 92.

Return to **Measurement** mode: press **Mode**  to start normal operation.

Application with Stillpipe

A stillpipe is recommended for products with a dK of less than 3, or if extremely turbulent or vortex conditions exist. This mounting arrangement can also be used to provide optimum signal conditions on foaming materials.

Notes:

- **Near Range (2.81.)** (Blanking) will be set at the factory. Check the Process Device Tag for specific values.
- Suitable pipe diameters are 40 mm (1.5") to 100 mm (4").
- The pipe diameter must be matched with the horn size. Use the largest horn size that will fit the stillpipe/bypass pipe (see *Flanged Horn dimensions* on page 156).
- See *Mounting on a Stillpipe or Bypass Pipe* on page 17 for installation guidelines.

This application is to obtain a level measurement and corresponding 4 to 20 mA output proportional to the oil level in a fuel storage vessel.

- Low Calibration Pt. is 5 m (16.5 ft) from the sensor reference point.
- High Calibration Pt. is 0.5 m (1.65 ft) from the sensor reference point.
- The stillpipe inside diameter is 50 mm (1.96").
- The maximum rate of filling or emptying is about 0.1 m (4")/min.

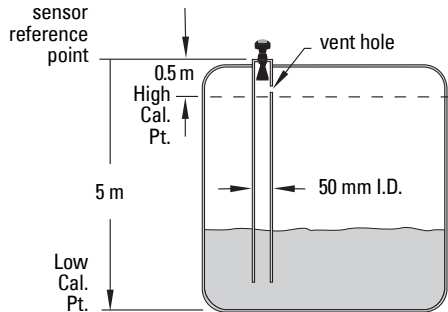

Parameter type	Parameter No./Name	Options/Values	Function
Quick Start Wizard	Material (1.2.)	LIQUID LOW DK	
	Response Rate (1.3.)	MED	Medium =1 m/minute
	Units (1.4.)	M	meters
	Operating Mode (1.5.)	LEVEL	Level is reported as Volume when a vessel shape is selected.
	Low Calibration Point (1.6.)	5	5 m (16.5 ft)
	High Calibration Point (1.7.)	0.5	0.5 m (1.64 ft)
	Apply? (Apply changes) (1.8.)	YES	Transfers Quick Start settings to device.

Parameter type	Parameter No./Name	Options/ Values	Function (cont'd)
Independent parameters	Propagation Factor (2.8.3.) ^{a)}	0.990	P.F for a 50 mm (1.96") I.D. stillpipe
	Position Detect (2.8.4.2.)	HYBRID	
	CLEF Range (2.8.4.4.) ^{a)}	4.3	4.3 m (14.10 ft)

a) The recommended values for the propagation factor and for CLEF range are dependent on the stillpipe diameter. Refer to the next table for values.

Propagation Factor/Stillpipe Diameter

Nominal Pipe Size ^{a)}	40 mm (1.5")	50 mm (2")	80 mm (3")	100 mm (4")
Propagation Factor	0.9828	0.990	0.991	0.9965
CLEF Range (2.8.4.4.) settings	Low Cal Pt. – 700 mm	Low Cal Pt. – 700 mm	Low Cal Pt. – 1000 mm	Low Cal Pt. – 1000 mm

a) Since pipe dimensions may vary slightly, the propagation factor may also vary.

Appendix F: HART Communications

Highway Addressable Remote Transducer, HART, is an industrial protocol that is superimposed on the 4-20 mA signal. It is an open standard, and full details about HART can be obtained from the HART Communication Foundation at www.hartcomm.org

SITRANS LR200 can be configured over the HART network using either the HART Communicator 375 by Fisher-Rosemount, or a software package. The recommended software package is the SIMATIC Process Device Manager (PDM) by Siemens.

SIMATIC PDM

This software package is designed to permit easy configuration, monitoring, and troubleshooting of HART devices. The HART EDD for SITRANS LR200 was written with SIMATIC PDM in mind and has been extensively tested with this software.

For more information, see *Operating via SIMATIC PDM* on page 35.

HART Electronic Device Description (EDD)

In order to configure a HART device, the configurator must have the HART Electronic Device Description for the instrument in question. HART EDDs are controlled by the HART Communication Foundation. Please check with the HART Communication Foundation for the availability of the HART EDD for SITRANS LR200. Older versions of the library will have to be updated in order to use all the features of SITRANS LR200.

HART Communicator 375 Menu Structure

Note: HART Communicator 375 is supported by SITRANS LR200 HART.

LEVEL METER

1. IDENTIFICATION

1. TAG
2. DESCRIPTION
3. MESSAGE
4. INSTALLATION DATE
5. DEVICE ORDER NUMBER

2. SETUP

1. DEVICE
 1. FIRMWARE REVISION
 2. LOADER REVISION
 3. HARDWARE REVISION
2. INPUT
 1. SENSOR CALIBRATION
 1. MATERIAL
 2. SENSOR UNITS
 3. OPERATION
 4. LOW CALIBRATION PT.
 5. HIGH CALIBRATION PT.
 6. NEAR RANGE
 7. FAR RANGE
 8. PROPAG. FACTOR
 9. SENSOR OFFSET
 2. VOLUME CONVERSION
 1. VESSEL SHAPE
 2. MAXIMUM VOLUME
 3. DIMENSION A
 4. DIMENSION L
 3. VOLUME BREAKPOINT
 1. TABLE 1 – 8 (Lev./Vol. Breakpoints 1-8)
 2. TABLE 9 – 16 (Lev./Vol. Breakpoints 9-16)
 3. TABLE 17 – 24 (Lev./Vol. Breakpoints 17-24)
 4. TABLE 25 – 32 (Lev./Vol. Breakpoints 25-32)
 4. ECHO PROCESSING
 1. ECHO SELECT
 1. ALGORITHM
 2. POSITION DETECT
 3. ECHO THRESHOLD
 2. SAMPLING
 1. ECHO LOCK
 2. SAMPLING UP
 3. SAMPLING DOWN
 3. FILTERING
 1. DAMPING FILTER
 4. TANK BOTTOM ALGORITHM
 1. CLEF RANGE

ECHO PROC (continued)

5. NOISE

1. ECHO CONFIDENCE
2. ECHO STRENGTH
3. NOISE AVERAGE

5. TVT SETUP

1. TVT HOVER LEVEL
2. AUTO FALSE ECHO SUPPRESSION
3. AUTO SUPPRESSION RANGE
4. SHAPER MODE

6. TVT SHAPER

1. SHAPER 1-9 (Shaper Points 1-9)
2. SHAPER 10-18 (Shaper Points 10-18)
3. SHAPER 19-27 (Shaper Points 19-27)
4. SHAPER 28-36 (Shaper Points 28-36)
5. SHAPER 37-40 (Shaper Points 37-40)

7. RATE

1. RESPONSE RATE
2. FILL RATE PER MINUTE
3. EMPTY RATE PER MINUTE

3. OUTPUT

1. MA OUTPUT

1. MA OUTPUT FUNCTION
2. 4 MA SETPOINT
3. 20 MA SETPOINT
4. MINIMUM MA LIMIT
5. MAXIMUM MA LIMIT

4. FAIL-SAFE

1. FAILSAFE TIMER
2. FAILSAFE MATERIAL LEVEL
3. FAILSAFE LEVEL

3. DIAGNOSTICS

1. MEASURED VALUES

1. CURRENT INTERNAL TEMP.
2. MAX. INTERNAL TEMP.
3. MIN. INTERNAL TEMP.

4. SERVICE

1. REMAINING DEVICE LIFETIME

1. TOTAL EXPECTED DEVICE LIFE
2. TOTAL DEVICE OPERATING TIME
3. REMAINING DEVICE LIFETIME
4. MAINTENANCE ALERT ACTIVATION
5. MAINTENANCE REQUIRED LIMIT
6. MAINTENANCE DEMANDED LIMIT
7. DEVICE LIFETIME MAINTENANCE ACKNOWLEDGE

2. REMAINING SENSOR LIFETIME

1. TOTAL EXPECTED SENSOR LIFE
2. TOTAL SENSOR OPERATING TIME
3. REMAINING SENSOR LIFETIME
4. MAINTENANCE ALERT ACTIVATION
5. MAINTENANCE REQUIRED LIMIT
6. MAINTENANCE DEMANDED LIMIT
7. SENSOR LIFETIME MAINTENANCE ACKNOWLEDGE

3. SERVICE INTERVAL
 1. TOTAL SERVICE INTERVAL
 2. TIME ELAPSED SINCE LAST SERVICE
 3. REMAINING LIFETIME
 4. MAINTENANCE ALERT ACTIVATION
 5. MAINTENANCE REQUIRED LIMIT
 6. MAINTENANCE DEMANDED LIMIT
 7. SERVICE ACKNOWLEDGE
 4. CALIBRATION INTERVAL
 1. TOTAL CALIBRATION INTERVAL
 2. TIME ELAPSED SINCE LAST CALIBRATION
 3. REMAINING LIFETIME
 4. MAINTENANCE ALERT ACTIVATION
 5. MAINTENANCE REQUIRED LIMIT
 6. MAINTENANCE DEMANDED LIMIT
 7. CALIBRATION ACKNOWLEDGE
 5. POWERED DAYS
 6. POWER-ON RESETS
 7. LCD FAST MODE
 8. LCD CONTRAST
5. **COMMUNICATION**
 1. COMM. CONTROL
 6. **SECURITY**
 1. WRITE PROTECT
 2. PIN TO UNLOCK
 7. **LANGUAGE**
 1. LANGUAGE

HART Version

SITRANS LR200 conforms to HART rev. 5.

Burst Mode

SITRANS LR200 does not support burst mode.

HART Multidrop Mode

We do not recommend the use of HART Multidrop Mode.

Appendix G: Flange Adapter Versions

Dimensions:

Threaded connection, PTFE Rod

! WARNING: For pressure applications, it will be necessary to use PTFE tape or other appropriate thread sealing compound, and to tighten the process connection beyond hand-tight.

Notes:

- Process temperature and pressure capabilities are dependent upon information on the process device tag. Reference drawing listed on the tag is available on the product page of our website at: www.siemens.com/LR200, under **More Info/Installation drawings/Level Measurement/Installation Drawings/LR200**.
- Additional information on process connections is available on the Installation Drawings page under **Process Connection Diagrams**.

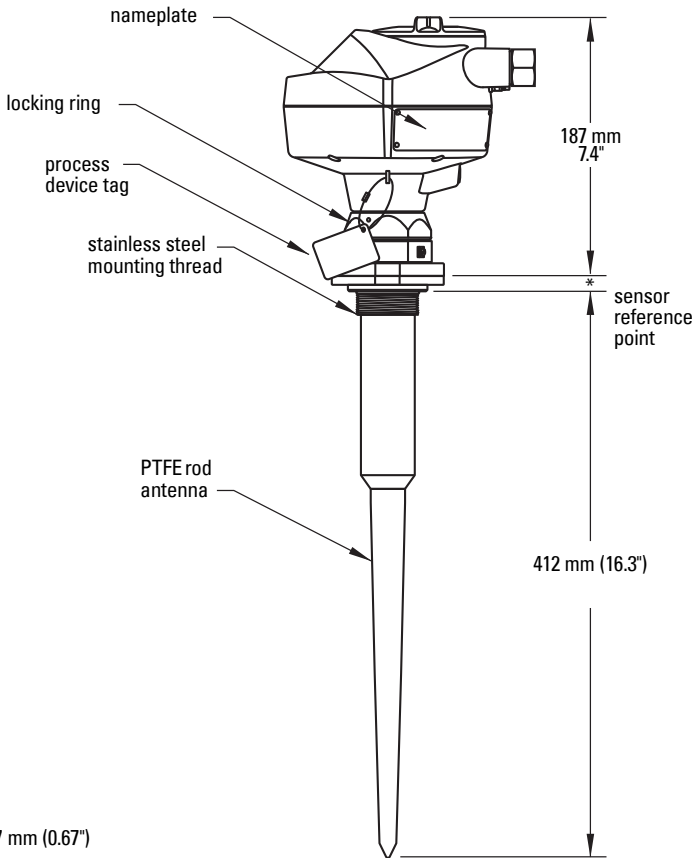

* 17 mm (0.67")

PTFE Rod Antenna, Flat-Face¹⁾ Flange

Notes:

- Process temperature and pressure capabilities are dependent upon information on the process device tag. Reference drawing listed on the tag is available on the product page of our website at: www.siemens.com/LR200, under **More Info/Installation drawings/Level Measurement/Installation Drawings/LR200**.
- Additional information on process connections is available on the Installation Drawings page under **Process Connection Diagrams**.
- For other flange dimensions and bolt hole sizing see *Flat-Face Flange Dimensions* on page 163.

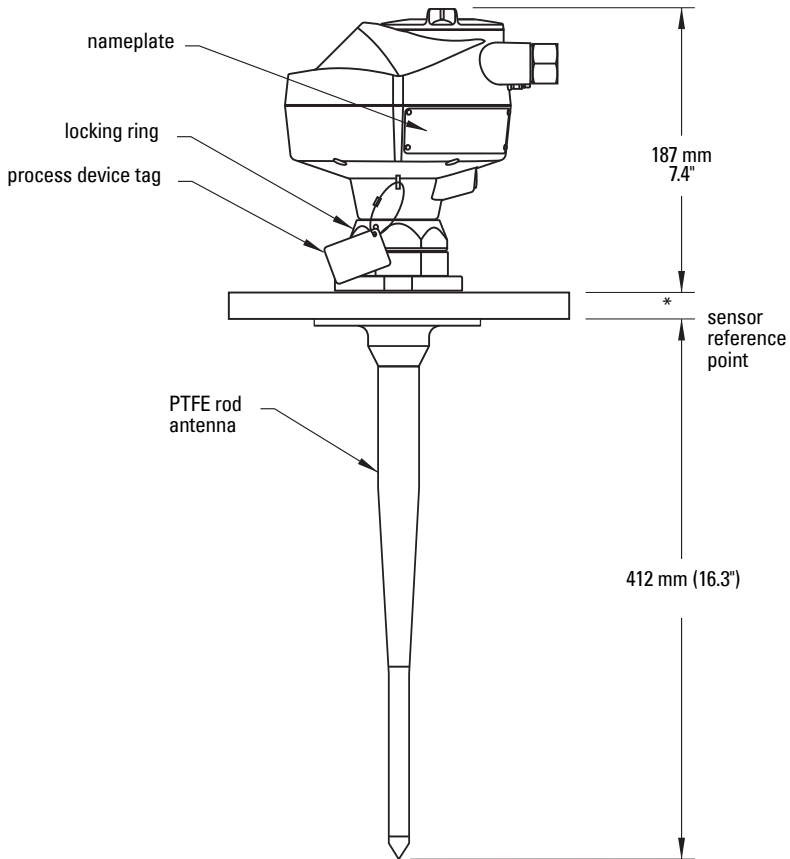

*Flange thickness: FF (flat-face) = 20 mm (0.80") nominal
RF (raised-face): thickness depends on flange size. See *Raised-Face Flange Dimensions* on page 161.

¹⁾ Constant thickness series.

Threaded Connection, PTFE Rod, external shield

! WARNING: For pressure applications, it will be necessary to use PTFE tape or other appropriate thread sealing compound, and to tighten the process connection beyond hand-tight.

Notes:

- Process temperature and pressure capabilities are dependent upon information on the process device tag. Reference drawing listed on the tag is available on the product page of our website at: www.siemens.com/LR200, under **More Info/Installation drawings/Level Measurement/Installation Drawings/LR200**.
- Additional information on process connections is available on the Installation Drawings page under **Process Connection Diagrams**.

G: Antenna Options

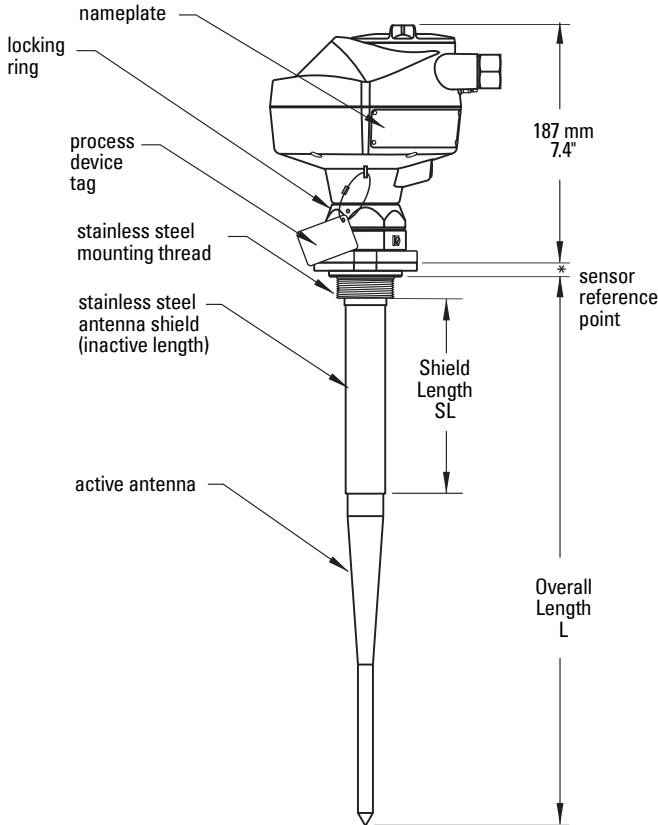

SL = min. 100 mm (4"), customer-specified
 L = 374 mm (14.7") plus shield length
 * 17 mm (0.67")

Flat-Face¹⁾ Flange with Horn Antenna and Waveguide extension

Notes:

- For other flange dimensions and bolt hole sizing see *Flat-Face Flange Dimensions* on page 163 or *Raised-Face Flange Dimensions* on page 161.
- See *Flanged Horn dimensions* on page 156 for more details.
- Process temperature and pressure capabilities are dependent upon information on the process device tag. Reference drawing listed on the tag is available on the product page of our website at: www.siemens.com/LR200, under **More Info/Installation drawings/Level Measurement/Installation Drawings/LR200**.
- Additional information on process connections is available on the Installation Drawings page under **Process Connection Diagrams**.
- Optional waveguide extensions and/or purging²⁾ system can be installed between the flange and the antenna.

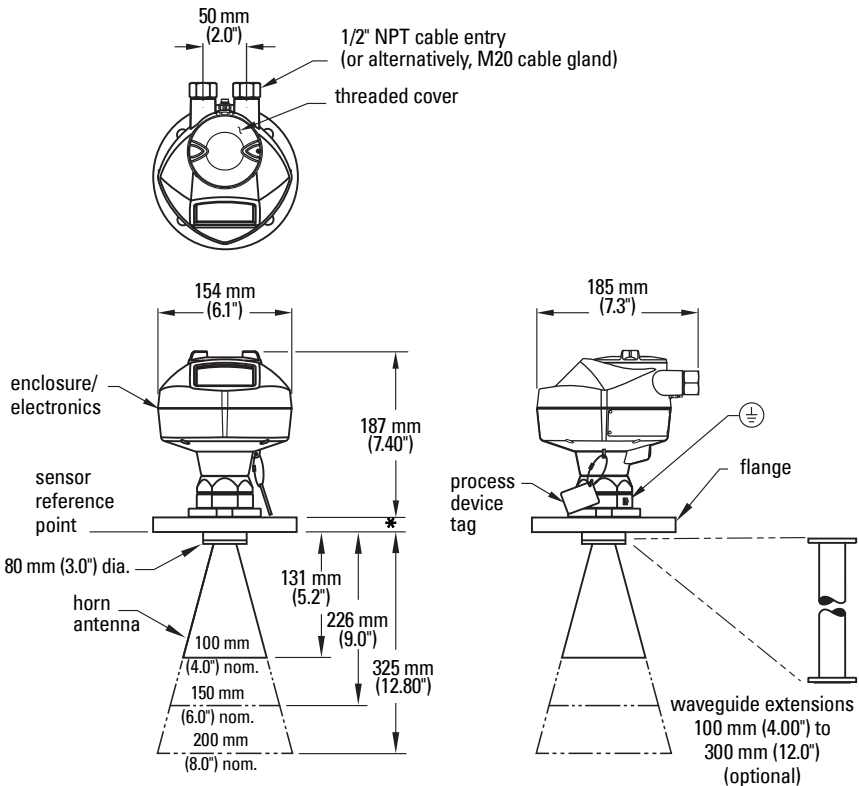

¹⁾ Constant thickness series.

²⁾ A purging system is an option available for this antenna type. This provides an inlet on the flange where cooling air or cleaning fluid may be supplied. The air or liquid passes through the flange and exits the inside of the horn to clean the antenna system.

Flanged Horn dimensions

Notes:

- Signal amplitude increases with horn diameter, so use the largest practical size.
- 80 mm (3") and 100 mm (4") are not recommended in vessels due to the wide beam/poor performance. They are to be used in stillpipe applications only.

Nominal Horn Size	Horn O.D.	Height to sensor reference point ^{a)}	Beam Angle ^{b)}	Measurement Range
100 mm (4")	95.3 mm (3.75")	131.0 mm (5.16")	29 degrees	20 m (65.6 ft)
150 mm (6")	146.0 mm (5.75")	225.8 mm (8.89")	20 degrees	
200 mm (8")	199.4 mm (7.85")	325.1 mm (12.79")	17 degrees	

- a) Height from bottom of horn to sensor reference point as shown: see *Flat-Face Flange with Horn Antenna and Waveguide extension* on page 155, *Raised Face or Flat-Face Flange with Waveguide* on page 157, or *Sliding Waveguide Configuration* on page 158.
- b) – 3dB in the direction of the polarization axis (see *Polarization reference point* on page 17 for an illustration).

Raised Face¹⁾ or Flat-Face²⁾ Flange with Waveguide

Notes:

- For other flange dimensions and bolt hole sizing see *Flat-Face Flange Dimensions* on page 163 or *Raised-Face Flange Dimensions* on page 161.
- You can connect a maximum of two waveguides together.
- This option is recommended only for clean liquids on vessels without agitators or turbulence.
- Horizontal stress on this antenna must be avoided, otherwise mechanical support may be required.
- Process temperature and pressure capabilities are dependent upon information on the process device tag. Reference drawing listed on the tag is available on the product page of our website at: www.siemens.com/LR200, under **More Info/Installation drawings/Level Measurement/Installation Drawings/LR200**.
- Additional information on process connections is available on the Installation Drawings page under **Process Connection Diagrams**.

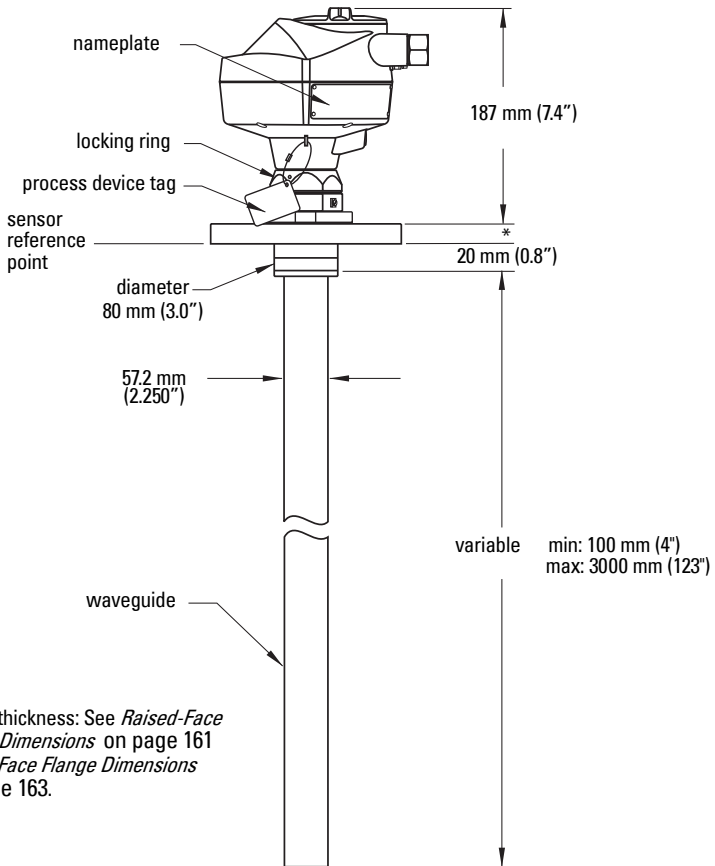

1) Per EN-1092-1.

2) Constant thickness series.

Sliding Waveguide Configuration

Notes:

- Always clamp the instrument in the same position for operation.
- For other flange dimensions and bolt hole sizing see *Flat-Face Flange Dimensions* on page 163.
- Maximum pressure 0.5 bar at 60° C (140° F) for sliding flange option.
- Process temperature and pressure capabilities are dependent upon information on the process device tag. Reference drawing listed on the tag is available on the product page of our website at: www.siemens.com/LR200, under **More Info/Installation drawings/Level Measurement/Installation Drawings/LR200**.
- Additional information on process connections is available on the Installation Drawings page under **Process Connection Diagrams**.

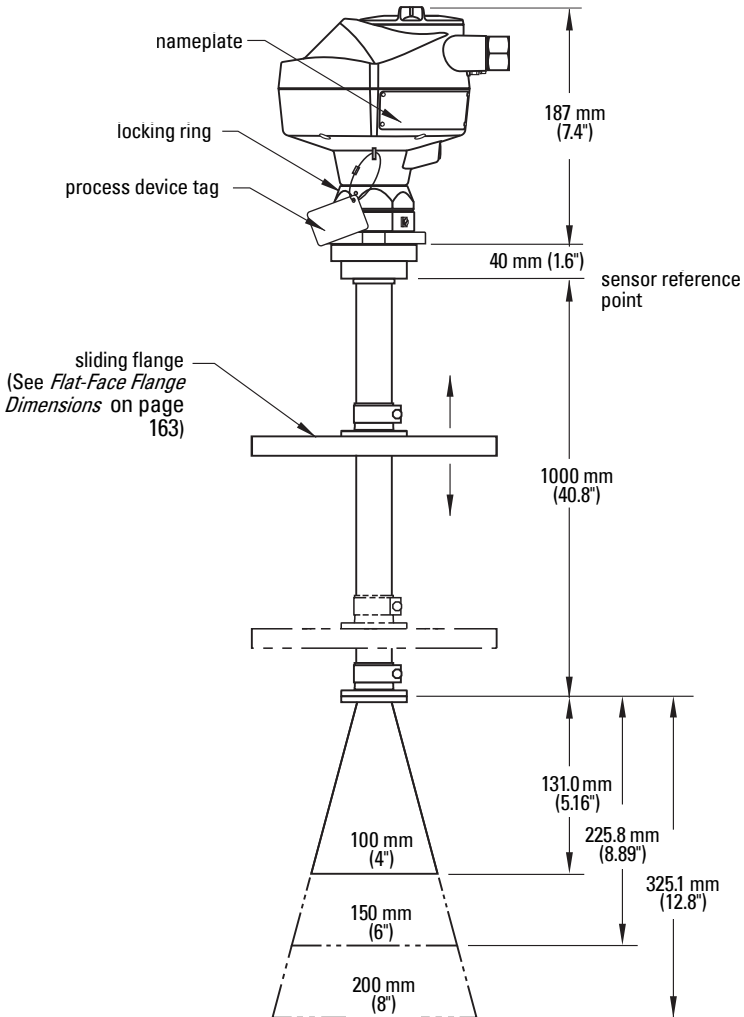

Sanitary connection, Rod Antenna, PTFE or HDPE

Notes:

- Process temperature and pressure capabilities are dependent upon information on the process device tag. Reference drawing listed on the tag is available on the product page of our website at: www.siemens.com/LR200, under **More Info/Installation drawings/Level Measurement/Installation Drawings/LR200**.
- Additional information on process connections is available on the Installation Drawings page under **Process Connection Diagrams**.

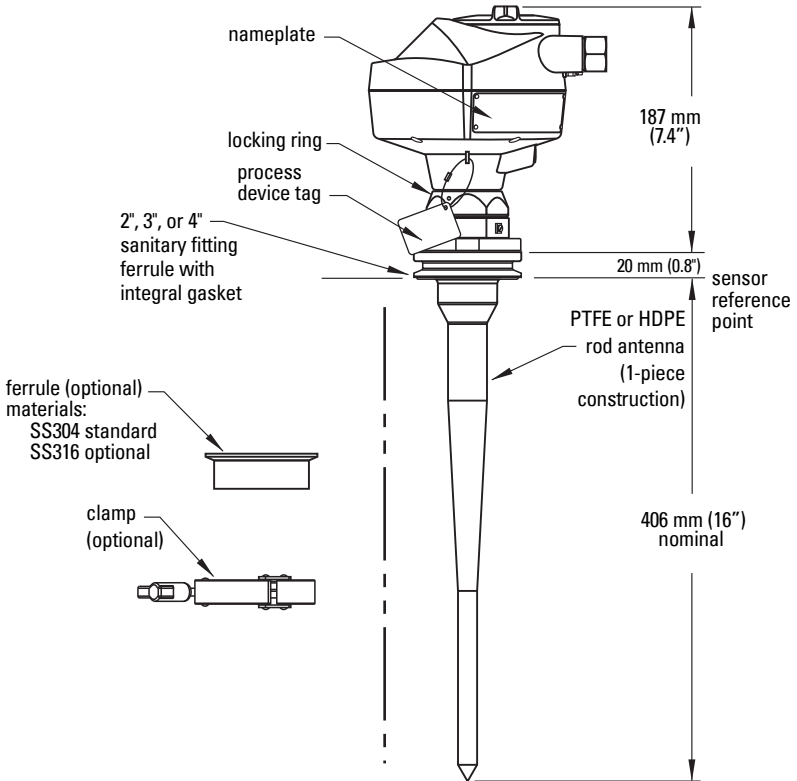

Raised-Face Flange per EN 1092-1

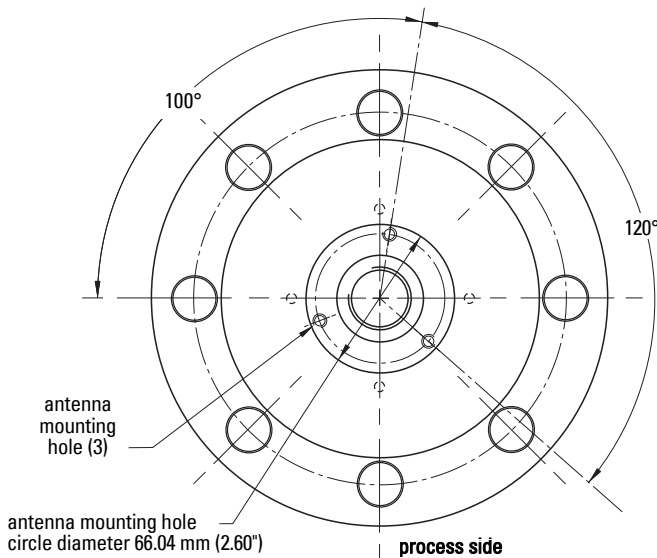
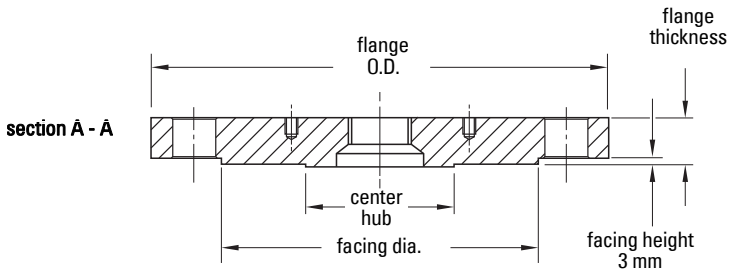
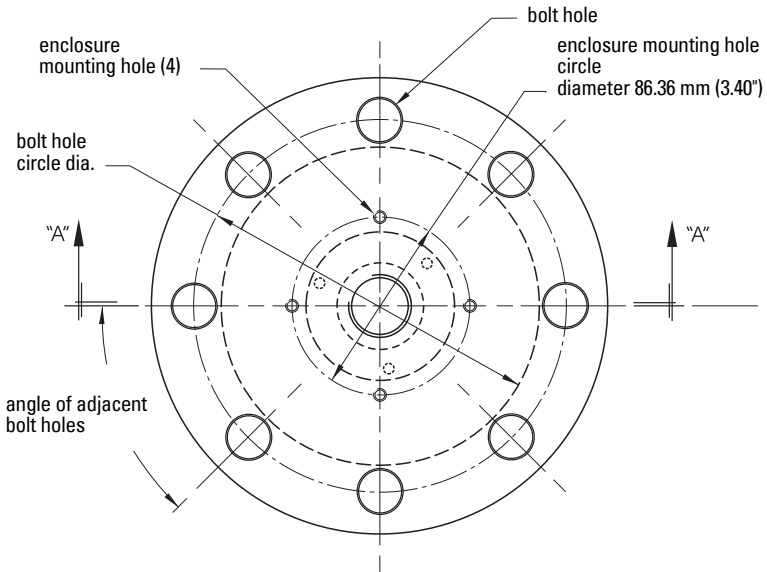

Raised-Face Flange Dimensions

Pipe size	Flange bolt hole pattern	Flange O.D. (mm)	Bolt Hole Circle Ø (mm)	Bolt Hole Ø (mm)	No. of Bolts	Angle of adjacent bolt holes	Facing Ø (mm)	Thickness (mm)
DN80	PN10/PN16	200	160	18	8	45	138	20
DN100	PN10/PN16	220	180	18	8	45	158	20
DN150	PN10/PN16	285	240	22	8	45	212	22
DN200	PN10/PN16	340	295	22	12	30	268	24
DN80	PN25/PN40	200	160	18	8	45	138	24
DN100	PN25/PN40	235	190	22	8	45	162	24
DN150	PN25/PN40	300	250	26	8	45	218	28

Raised-Face¹⁾ Flange markings

Flange Standard; Nominal Size; Material; Heat Code	Serial no.	Logo	Heat Code no.	Facing
EN 1092-1 05 'B1'; 'DN80' 'PN16' '1.4404 or 1.4435' A1B2C3	mmddyxxx		A1B2C3	RF

The flange markings are located around the outside edge of the flange.

Serial number: a unique number allotted to each flange, including the date of manufacture (MMDDYY) followed by a number from 001 to 999.

Flange series: the Siemens Milltronics drawing identification.

Heat code: a flange material batch code identification.

Facing: Defines RF option.

¹⁾ Per EN 1092-1.

Flat-Face Flange (constant thickness series)

See *Flat-Face Flange Dimensions* on page 163 for details.

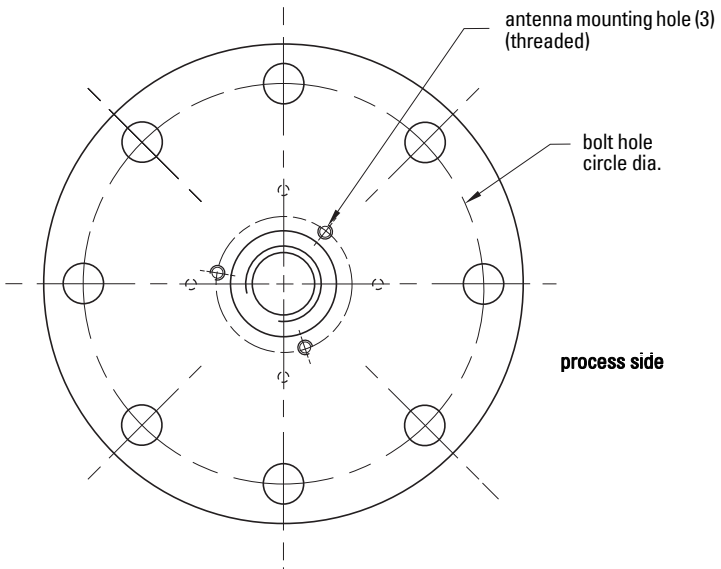
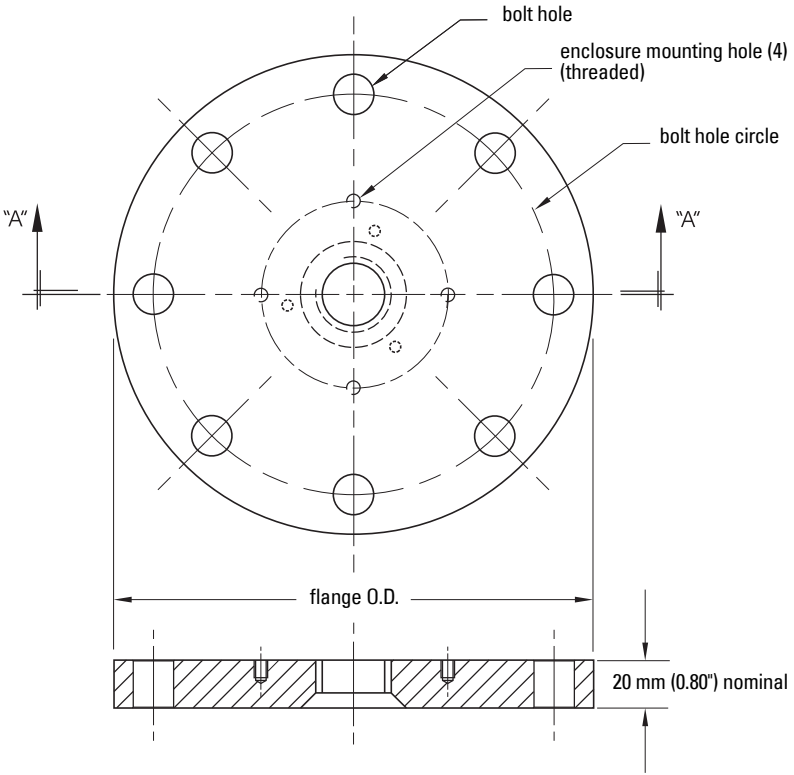

Flat-Face¹⁾ Flange Dimensions

Pipe size	Flange Size	Flange O.D.	Bolt Hole Circle Ø	Bolt Hole Ø	Number of Bolts
2"	ASME 150 lb	6.0"	4.75"	.75"	4
3"	ASME 150 lb	7.5"	6.0"	.75"	4
4"	ASME 150 lb	9.0"	7.50"	.75"	8
6"	ASME 150 lb	11.0"	9.50"	.88"	8
8"	ASME 150 lb	13.5"	11.75"	.88"	8
2"	ASME 300 lb ^{a)}	6.50"	5.00"	.75"	4a)
3"	ASME 300 lb	8.25"	6.62"	.88"	8
4"	ASME 300 lb	10.00"	7.88"	.88"	8
6"	ASME 300 lb	12.50"	10.62"	.88"	12
8"	ASME 300 lb	15.00"	13.00"	1.00"	12
DN50	PN16	165 mm	125 mm	18 mm	4
DN80	PN16	200 mm	160 mm	18 mm	8
DN100	PN16	220 mm	180 mm	18 mm	8
DN150	PN16	285 mm	240 mm	22 mm	8
DN200	PN16	340 mm	295 mm	22 mm	12
DN200	PN25	360 mm	310 mm	26 mm	12
DN50	PN40	165 mm	125 mm	18 mm	4
DN80	PN40	200 mm	160 mm	18 mm	8
DN100	PN40	235 mm	190 mm	22 mm	8
DN150	PN40	300 mm	250 mm	26 mm	8
DN200	PN40	375 mm	320 mm	30 mm	12
50A	JIS 10K	155 mm	120 mm	19 mm	4
80A	JIS 10K	185 mm	150 mm	19 mm	8
100A	JIS 10K	210 mm	175 mm	19 mm	8
150A	JIS 10K	280 mm	240 mm	23 mm	8
200A	JIS 10K	330 mm	290 mm	23 mm	12

a) Due to the limited space on this flange, SITRANS LR200 can only use 4 of the standard 8 bolt holes of the 2" ASME 300 lb size.

¹⁾ Constant thickness series.

Flat-Face¹⁾ Flange markings

Flange markings located around the outside edge of the flat-face flange identify the flange assembly on which the device is mounted.

Flat Face Flange Identification						Welded Assembly Identification		
Serial No.	Logo	Flange Series		Material	Heat Code	Flange Series	Heat Code No.	
		Series	Nominal Size					
MMDDYYXXX		25556	2	150	316L/ 1.4404 or 316L/ 1.4435	A1B2C3	25546	A1B2C3
			DN 80	PN16				

Serial number: a unique number allotted to each flange, including the date of manufacture (MMDDYY) followed by a number from 001 to 999.

Flange series: the Siemens Milltronics drawing identification.

Nominal size: the flange size followed by the hole pattern for a particular flange class. For example,

- a 2 inch ANSI B 16.5 150 lb class flange (North America)
- a DN 80 EN 1092-1 PN16 class flange (Europe).

Material: the basic flange material (AISI or EU material designation). North American material codes are followed by European ones. For example, material designation 316L/1.4404.

Heat code: a flange material batch code identification.

Threaded Connection Markings

Threaded connection markings are found on the flat face/faces of the process connection.

Logo	Serial Number	Thread Size	Thread Series
	MMDDYYXXX	1.5	NPT
			BSP
			G/PF

Serial number: a unique number allotted to each flange, including the date of manufacture (MMDDYY) followed by a number from 001 to 999.

¹⁾ Constant thickness series.

Flange Mounting Instructions

Notes:

- The integral process seal MUST rest on the customer-supplied flange (see the detail below).
- The straight/taper transition of the rod should extend past the nozzle/vessel opening. Add extensions as required¹⁾.

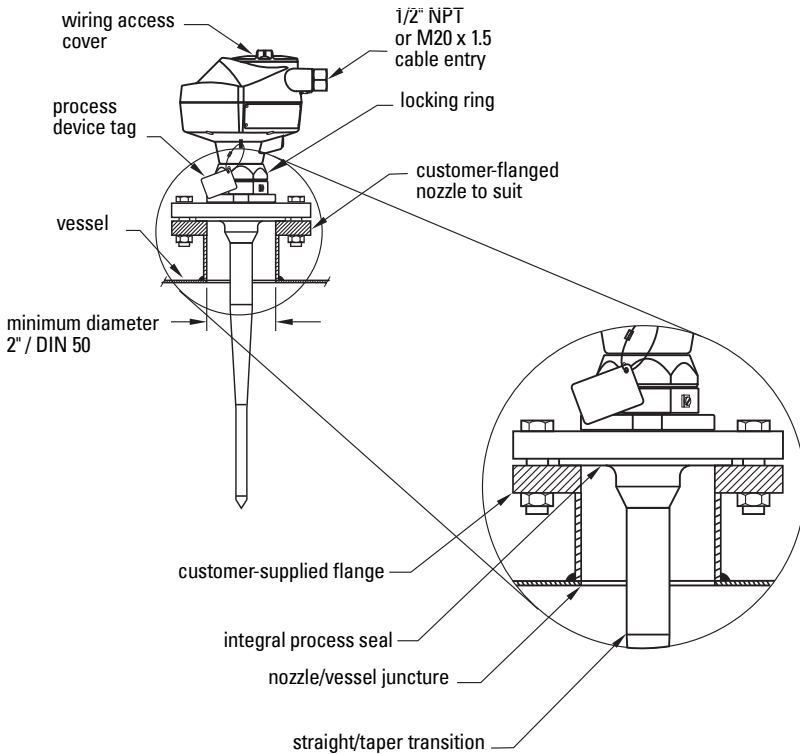

* Refer to the *Rod Extension Requirements* table on page 166.

¹⁾ Refer to the *Rod Extension Requirements* table on page 166

Rod Assembly

! WARNING: For pressure applications, it will be necessary to use PTFE tape or other appropriate thread sealing compound, and to tighten the process connection beyond hand-tight.

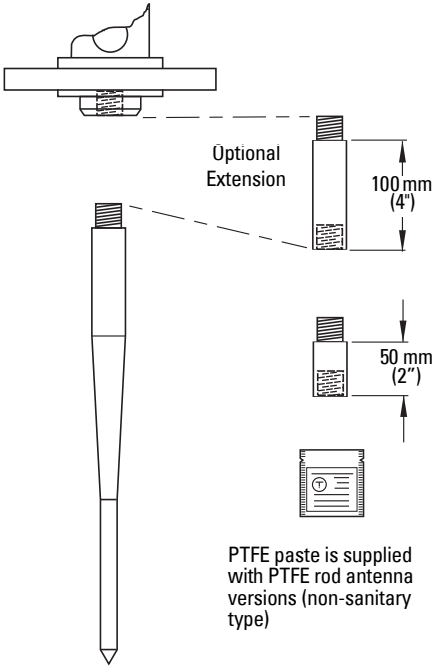

Notes:

- Water or process fluids must not enter the connecting threads: this could cause reflections at the connection, which will appear as false echoes.
- Apply a small amount of PTFE paste to the antenna threads before threading the antenna together, and tighten slowly. Ensure that the rod sections mate securely with no gaps. Do not apply too much PTFE paste or the parts will not mate securely.
- Do not use wrenches or pliers. Hand tighten only (except in pressure applications: see warning above).

Rod Extension Requirements

Nozzle I.D.	Nozzle Height ^{a)} mm (inches)		
	<100 (4)	100 to 150 (4 to 6)	150 to 200 (6 to 8)
50 mm (2")	extension not required	Application not recommended for 50 mm (2") I.D. nozzles longer than 100 mm (4") ^{b)} .	
80 mm (3")		50 mm	100 mm
100 mm (4")		50 mm	100 mm
150 mm (6")		50 mm	100 mm
>150 mm (6")	extension not required		

- a) Consult Siemens Milltronics for assistance with nozzle sizes not listed.
- b) Shielded rod antennas are available for these applications.

G: Antenna Options

Mounting Guidelines

Nozzle fabrication

Weld seams must be on the outside of the nozzle. Seams or lips on the inside of the nozzle may cause erratic readings.

Nozzle design

- The nozzle should be as short as possible.
- If your application requires a nozzle longer than our recommended maximum length consider using a shielded rod.

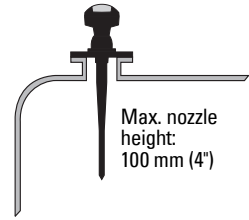

Horn Antennas

The end of the horn should protrude a minimum of 10 mm (0.4") to avoid interference from the nozzle.

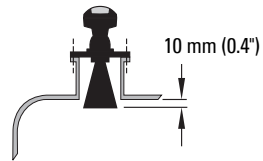

Threaded Rod Antenna

! WARNING: For pressure applications, it is necessary to use PTFE tape or other appropriate thread sealing compound, and to tighten the process connection beyond hand-tight.

1.5" or 2" threaded process connections are available in three thread types: NPT, BSP, and G.

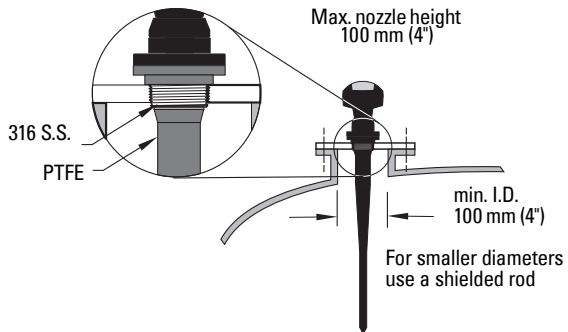

Sanitary Rod Antenna

2", 3", and 4" sanitary fitting ferrule with integral gasket, with rod antenna

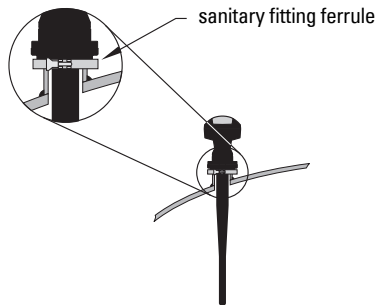

Waveguide Antenna

Notes:

- You can connect a maximum of two waveguides together.
- This option is recommended only for clean liquids, and only on vessels without an agitator, with no turbulence.
- Horizontal stress on this antenna must be avoided, otherwise mechanical support may be required.
- Process temperature and pressure capabilities are dependent upon information on the process device tag. The reference drawing listed on the tag can be downloaded from our website at: www.siemens.com/LR200.

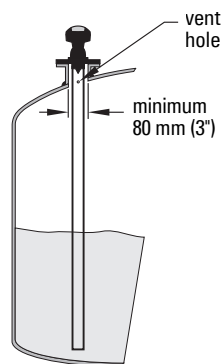

- Recommended for products with a dK lower than 3.
- See **Propagation Factor (2.8.3)** on page 87 for the related propagation factor.

Horn with Waveguide Extensions

- Recommended for long nozzles with a small diameter.

For example, if the nozzle is 100 mm (4") in diameter and 460 mm (18") in length, the rod antenna is not suitable due to interference from the nozzle.

- Waveguide extensions are available in custom lengths.
- The horn must be connected to the SITRANS LR200 process flange.

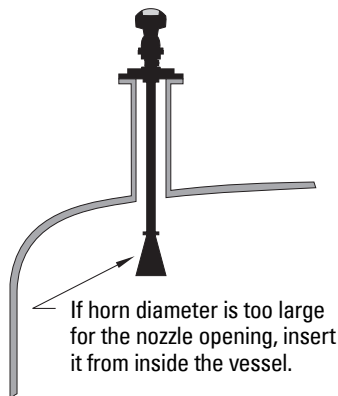

Appendix H: Firmware Revision History

Firm-ware Rev.	PDM EDD Rev.	Date	Changes
1.00	1.00	6 May 2003	<ul style="list-style-type: none"> Initial Release
1.01		26 Jun 2003	<ul style="list-style-type: none"> Factory calibration of antenna offset can now be saved.
1.02		16 Oct 2003	<ul style="list-style-type: none"> Sporadic Fault 25 (electronic failure) messages reduced.
1.03	2.00	16 Mar 2004	<ul style="list-style-type: none"> Cleaned up fault code issues. Set HART status bit 4 (more status available) MEASURE key works only on restricted set of parameters while in program mode. Made corrections to language strings. Corrected User Interface operation at -30°C. Fixed Fault 25 (electronic failure) caused by an RTM glitch on the RAMP_TH line. PDM TVT profile was sometimes lacking a few bytes at the end. This is now fixed. Added TVT Shaper to HART: P831 to cmd 172 and create cmd 174 for P832. Improved mA output time at startup. Product startup time reduced from about 30 seconds to about 10 seconds. P838 now does not reset. P831 and P832 TVT shaper added. P054 and P054 breakpoints corrected for PDM.
1.04	2.00	27 May 2004	<ul style="list-style-type: none"> Fixed possible corruption of HART Status. Prevent possible buffer overflows. Fixed HART command 17 to correct status information. Changes made to the program mode timer to avoid an immediate timeout followed by a switch to run mode when the device is switched into program mode via HART. The configuration changed status can now be saved for the duration of a power cycle.

Firm-ware Rev.	PDM EDD Rev.	Date	Changes (cont'd)
1.04 (cont'd)	2.00 (cont'd)	27 May 2004	<ul style="list-style-type: none"> HART commands 170 and 171 modified to read and write P713. Configuration status now being set for all required commands. HART common practice and universal commands now return response codes. When the full configuration is transferred to a unit, Span is reset to the default value. HART command 225 now sets the manual Span flag when P007 is set. Added new HART command 229 to provide a write for P799.
1.05		10 Aug 2004	<ul style="list-style-type: none"> Corrected issue: P210 and P211 values (or HART values for URV/LRV) were not being preserved over a power cycle if operation was set to distance or volume.
3.02	3.02.01	27 Feb 2006	<ul style="list-style-type: none"> Resolved issue that could cause peak to be selected below the TVT curve. MP&F parameters added to device. Fault system upgraded to use S# codes to match PROFIBUS products. Increased number of level/volume breakpoints to 32. Improved linearity over ambient temperature. <p>NOTE: Software revision 3.02 is not backwards compatible due to hardware compatibility.</p>
4.01.00	4.01.02	22 Feb 2008	<ul style="list-style-type: none"> New Local User Interface
4.02.00	4.02.00	2 Apr 2009	<ul style="list-style-type: none"> AMS EDD Rev. 1.01.01 Support NAMUR NE 43. Harmonization of menu structures and parameter names across products. Display indicates progress towards first measurement.
4.02.02	4.02.02	16 Jun 2010	<ul style="list-style-type: none"> Display contrast improvement. Antenna type parameter cannot be modified.

Glossary

accuracy: degree of conformity of a measure to a standard or a true value.

agitator: mechanical apparatus for mixing or aerating. A device for creating turbulence.

algorithm: a prescribed set of well-defined rules or processes for the solution of a problem in a finite number of steps.

ambient temperature: the temperature of the surrounding air that comes in contact with the enclosure of the device.

antenna: an aerial which sends out and receives a signal in a specific direction. There are four basic types of antenna in radar level measurement, horn, parabolic, rod, and waveguide.

attenuation: a term used to denote a decrease in signal magnitude in transmission from one point to another. Attenuation may be expressed as a scalar ratio of the input magnitude to the output magnitude or in decibels.

Auto False-Echo Suppression: a technique used to adjust the level of a TVT to avoid the reading of false echoes. (See TVT.)

Auto False-Echo Suppression Distance: defines the endpoint of the TVT distance. (See TVT.) This is used in conjunction with auto false echo suppression.

beam width: the angle diametrically subtended by the one-half power limits (-3 dB) of the microwave beam.

beam spreading: the divergence of a beam as it travels through a medium.

blanking: a blind zone extending away from the reference point plus any additional shield length. The instrument is programmed to ignore this zone.

capacitance: the property of a system of conductors and dielectrics that permits the storage of electricity when potential differences exist between the conductors. Its value is expressed as the ratio of a quantity of electricity to a potential difference, and the unit is a Farad.

confidence: see **Echo Confidence**

damping: term applied to the performance of an instrument to denote the manner in which the measurement settles to its steady indication after a change in the value of the level.

dB (decibel): a unit used to measure the amplitude of signals.

derating: to decrease a rating suitable for normal conditions according to guidelines specified for different conditions.

dielectric: a nonconductor of direct electric current.¹⁾

dielectric constant (dK): the ability of a dielectric to store electrical potential energy under the influence of an electric field. Also known as Relative Permittivity. An increase in the dielectric constant is directly proportional to an increase in signal amplitude. The value is usually given relative to a vacuum /dry air: the dielectric constant of air is 1¹.

echo: a signal that has been reflected with sufficient magnitude and delay to be perceived in some manner as a signal distinct from that directly transmitted. Echoes are frequently measured in decibels relative to the directly transmitted signal.

Echo Confidence: describes the quality of an echo. Higher values represent higher quality. Echo Threshold defines the minimum value required for an echo to be accepted as valid and evaluated.

Echo Lock Window: a window centered on an echo in order to locate and display the echo's position and true reading. Echoes outside the window are not immediately processed.

Echo Marker: a marker that points to the processed echo.

Echo Processing: the process by which the radar unit determines echoes.

Echo Strength: describes the strength of the selected echo in dB referred to 1 μ V rms.

Echo Profile: a graphical display of a processed echo.

false echo: any echo which is not the echo from the desired target. Generally, false echoes are created by vessel obstructions.

frequency: the number of periods occurring per unit time. Frequency may be stated in cycles per second.

Hertz (Hz): unit of frequency, one cycle per second. 1 Gigahertz (GHz) is equal to 10⁹ Hz.

HART: Highway Addressable Remote Transducer. An open communication protocol used to address field instruments.

horn antenna: a conical, horn-shaped antenna which focuses microwave signals. The larger the horn diameter, the more focused the radar beam.

inductance: the property of an electric circuit by virtue of which a varying current induces an electromotive force in that circuit or in a neighboring circuit. The unit is a Henry.

microwaves: the term for the electromagnetic frequencies occupying the portion of the radio frequency spectrum from 1 GHz to 300 GHz.

¹⁾ Many conductive liquids/electrolytes exhibit dielectric properties; the relative dielectric constant of water is 80.

multiple echoes: secondary echoes that appear as double, triple, or quadruple echoes in the distance from the target echo.

Near Blanking: see Blanking

nozzle: a length of pipe mounted onto a vessel that supports the flange.

parameters: in programming, variables that are given constant values for specific purposes or processes.

polarization: the property of a radiated electromagnetic wave describing the time-varying direction and amplitude of the electric field vector.

polarization error: the error arising from the transmission or reception of an electromagnetic wave having a polarization other than that intended for the system.

propagation factor (pf): where the maximum velocity is 1.0, pf is a value that represents a reduction in propagation velocity as a result of the wave travelling through a pipe or medium.

pulse radar: a radar type that directly measures distance using short microwave pulses. Distance is determined by the return transit time.

radar: radar is an acronym for **RA**dio **D**etection **A**nd **R**anging. A device that radiates electromagnetic waves and utilizes the reflection of such waves from distant objects to determine their existence or position.

range: distance between a transmitter and a target.

range extension: the distance below the zero percent or empty point in a vessel.

relative humidity: the ratio of the actual amount of moisture in the atmosphere to the maximum amount of moisture the atmosphere could hold (which varies depending on the air temperature).

relative permittivity: see dielectric constant.

repeatability: the closeness of agreement among repeated measurements of the same variable under the same conditions.

sensor value: the value produced by the echo processing which represents the distance from sensor reference point to the target. (see **Sensor Mode (2.2.2.)** on page 76 for an illustration).

shot: one transmit pulse or measurement.

speed of light: the speed of electromagnetic waves (including microwave and light) in free space. Light speed is a constant 299, 792, 458 meters per second.

stillpipe: a pipe that is mounted inside a vessel parallel to the vessel wall, and is open to the vessel at the bottom.

stilling-well: see **stillpipe**.

two wire radar: a low-energy radar. Can be loop powered, analog, intrinsically safe 4 to 20 mA, or a digital (BUS) transmitter.

TVT (Time Varying Threshold): a time-varying curve that determines the threshold level above which echoes are determined to be valid.

waveguide antenna: a hollow, metallic tube that transmits a microwave signal to the product target.

Index

A

Abbreviations and Identifications
list 4

access control
remote access 111

activating SITRANS LR200 26

agitator blade detection
avoiding 90

AMS Device Manager
features 56

analog output
explanation 130
fail signal 7
select 51
signal range 7
simulate via PDM 52

analog output scale
setup 81

antenna
replacement 123

approvals 9

Auto False Echo Suppression 128
explanation 128
setup 92
setup via PDM 48

B

beam angle
values 156

beam angle spread 16

bypass pipe
installation 17

C

cables
requirements 19

Calibration Interval 106

cleaning

instructions 123

CLEF (Constrained Leading Edge Fit)
explanation 126

CLEF range
setup 89

communication
load 7
max. line length 7

conduits
requirements 19

configuration
new device via PDM 37
Quick Start via LUI 31

configuration flag reset 52

D

Damping
explanation 130

Damping Filter
setup 77

data logging
time-based echo profile storage 46

Device Address 111
setting via LUI 34

Device Description
see Electronic Device Description 148

Device Reset 96

device reset
see Master Reset 96

device status
view via PDM 54

Diagnostics 95

dimensions
flanges 161
horn antenna 157
PTFE threaded rod antenna 152
sanitary rod antenna 159
threaded horn 12
Uni-construction Polypropylene Rod
Antenna 12
waveguide 157

E

echo confidence
parameter setup 91

echo processing
Process Intelligence 124
process intelligence 124

echo profile
data logging 46
view via LUI 33
view via PDM 54

Echo Profile Utilities 45

echo selection
Algorithm 125
CLEF (Constrained Leading Edge Fit)
126

Position algorithm 125
time varying threshold (TVT) 125

Echo setup
 quick access 50

EDD
 Electronic Device Description 37

edit mode
 handheld programmer 29
 key functions 30

Electronic Device Description 148

Electronic Device Description (EDD) 37

emission cone
 illustration 16

enclosure
 opening 19

F

factory defaults
 Master Reset 96

Fail-safe
 settings 80

Fail-safe Mode
 explanation 132

Fail-safe Timer
 explanation 132

false echo
 see Auto False Echo Suppression 128

Far Range
 explanation 129
 setup 87

flange marking 164

flange markings 161

flange sizes
 chart 161, 163

function keys
 measurement mode 27
 navigation mode 29

H

handheld programmer
 edit mode 29
 measurement mode 27
 navigation 29

HART
 multidrop mode 151

HART communication
 set preambles 52

HART Communications
 details 148

HART version 7

hazardous area installations
 wiring requirements 21

I

Identifications and Abbreviations

 list 4

Index 175

installation
 enclosure rotating 18
 hazardous area requirements 21
 temperature guidelines 16
 vessel shape notes 15

internal temperature
 monitoring 133

K

key functions
 edit mode 30

L

Language 112

LCD display
 contrast adjustment 110
 echo profile viewing 33
 fast mode 109
 measurement mode 26

level application example
 via LUI 33

lid-lock set screw 19

linearization
 via PDM 41

linearization via AMS 60

Local User Interface (LUI) 26

locking ring 18

LOE
 Fail-safe Mode 132

loop test
 simulate analog output 52

Loss of Echo (LOE)
 explanation 132

LUI (Local User Interface) 26

M

mA output
 select analog output 51

maintenance
 calibration schedules via PDM 50
 cleaning 123
 service schedules via PDM 50

maintenance settings 95
 see Calibration Interval 106
 see Remaining Sensor Lifetime 102
 see Service Interval 103

Master Reset
 factory defaults 96
 factory defaults via AMS 58
 measurement range
 blanking via Near Range 129

- extension via Far Range 129
- Measurement Response
 - explanation 129
- mounting
 - bypass requirements 17
 - flange mounting instructions 165
 - flange-mounted options 167
 - handheld programmer access 15
 - manhole cover 15
 - nozzle design 15
 - nozzle location 15
 - on vessel with obstructions 17
 - stillpipe requirements 17
 - sunshield recommended 16
- multidrop mode 151
- N**
- Near Range
 - setup 87
- O**
- operating principles 124
- P**
- password protection
 - via AMS 68
 - via PDM 54
- performance
 - specifications 6
- PIN to unlock
 - local access 112
- pipe sizes
 - flange mounting 161, 163
- polarization reference point 17
- power 6
- power source
 - requirements 19
- principles of operation 124
- Process Intelligence 124
- process temperature
 - maximum 133
- programmer
 - handheld 27
- programming
 - adjust parameters via PDM 44
 - via the handheld programmer 28
- propagation factor
 - values 87
- Q**
- Quick Start Wizard
 - via LUI 31
 - via SIMATIC PDM 37

- R**
- reading erratic
 - troubleshooting 122
- reading incorrect
 - troubleshooting 121
- repair
 - antenna replacement 123
- reset
 - see Master Reset 96
- Response Rate
 - explanation 129
 - settings 78
- rod assembly 166
- rod extension requirements 166
- S**
- Scan Device
 - synchronize parameters via AMS 58
- security
 - local access 112
 - local access control via AMS 66
 - local access unlock value 112
 - password protection via AMS 68
 - password protection via PDM 54, 55
 - remote access control 111
 - remote access control via AMS 66
- self-test
 - device self-test via PDM 51
- sensor reference point
 - flanged horn 13
- settings
 - adjust parameters via LUI 28, 29
 - adjust parameters via PDM 44
- sidepipe
 - see bypass pipe 17
- SIMATIC PDM
 - functions and features 35
 - Rev. 5.2, SP1 features 36
 - Rev. 6.0, SP3 features 35
- simulate analog output
 - loop test 52
- specifications 6
 - ambient temperature 8
 - antenna 7
 - enclosure 7
 - environmental 8
 - performance 6
 - power 6
 - pressure 9
 - process connections 7
 - process temperature 9

- weight 7
- startup
 - transition screen 26
- startup curve 140
- stillpipe
 - installation 17
- stillpipe application
 - configuring via PDM 43
- synchronize parameters
 - scan device via AMS 58

T

- technical support
 - contact information 3
- temperature de-Rating
 - curves 134
- terminal access 19
- test
 - loop test 52
- threaded connection markings 161, 164
- trend
 - view trend line 53
- troubleshooting
 - communication 115
 - operation 121
- TVT (time varying threshold)
 - explanation 125
- TVT Shaper
 - manual adjustment via PDM 47

U

- unlock value
 - local access 112
- uploads/downloads
 - accelerated 84, 94

V

- vessel shape
 - installation notes 15
 - selection 83

W

- wear
 - view via PDM 55
- wiring
 - cables 19
 - connecting HART 20
 - hazardous areas 21
 - terminal access 19
- write protect
 - local access 112

LCD menu structure

LCD menu structure

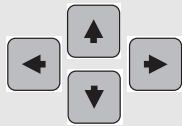

Notes:

- In Navigation mode **ARROW keys** navigate the menu in the direction of the arrow..
- See *Parameter Reference* on page 74 for detailed information and instructions.

LEVEL METER

1. QUICK START

- 1.1 LANGUAGE
- 1.2 MATERIAL
- 1.3 RESPONSE RATE
- 1.4 UNITS
- 1.5 OPERAT. MODE
- 1.6 LOW CALIB. PT.
- 1.7 HIGH CALIB. PT.
- 1.8 APPLY?

2. SETUP

- 2.1 DEVICE
 - 2.1.1 HARDWARE REV
 - 2.1.2 FIRMWARE REV
 - 2.1.3 LOADER REV
 - 2.1.4 ORDER OPTION
- 2.2 SENSOR
 - 2.2.1 UNITS
 - 2.2.2 SENSOR MODE
 - 2.2.3 MATERIAL
 - 2.2.4 DAMPING FILTER
 - 2.2.5 ANTENNA
- 2.3 CALIBRATION
 - 2.3.1 LOW CALIB. PT.
 - 2.3.2 HIGH CALIB. PT.
 - 2.3.3 SENSOR OFFSET
- 2.4 RATE
 - 2.4.1 RESPONSE RATE
 - 2.4.2 FILL RATE /MIN
 - 2.4.3 EMPTY RATE /MIN
- 2.5 FAIL-SAFE
 - 2.5.1 MATERIAL LEVEL
 - 2.5.2 TIMER
 - 2.5.3 LEVEL
- 2.6 ANALOG OUT. SCAL.
 - 2.6.1 CURR. OUT. FUNC.
 - 2.6.2 4 MA SETPOINT
 - 2.6.3 20 MA SETPOINT
 - 2.6.4 MIN. MA LIMIT
 - 2.6.5 MAX. MA LIMIT
 - 2.6.6 MA OUTPUT VALUE
- 2.7 LINEARIZATION
 - 2.7.1 VOLUME
 - 2.7.1.1 VESSEL SHAPE
 - 2.7.1.2 MAX. VOLUME

2. SETUP (cont'd)

- 2.7.3 DIMENS. A
- 2.7.4 DIMENS. L
- 2.7.1 TABLE 1 – 8
- 2.7.2 TABLE 9 – 16
- 2.7.3 TABLE 17 – 24
- 2.7.4 TABLE 25 – 32
- 2.8 SIGNAL PROC.
 - 2.8.1 NEAR RANGE
 - 2.8.4.1 ALGORITHM
 - 2.8.4.2 POS. DETECT
 - 2.8.4.3 ECHO THRESHOLD
 - 2.8.4.4 CLEF RANGE
 - 2.8.2 FAR RANGE
 - 2.8.3 PROPAG. FACTOR
 - 2.8.4 ECHO SELECT
 - 2.8.5 SAMPLING
 - 2.8.5.1 ECHO LOCK
 - 2.8.5.2 UP SAMP.
 - 2.8.5.3 DOWN SAMP.
 - 2.8.6 ECHO QUALITY
 - 2.8.6.1 CONFIDENCE
 - 2.8.6.2 ECHO STRENGTH
 - 2.8.6.3 NOISE AVERAGE
 - 2.8.7 TVT SETUP
 - 2.8.7.1 AUTO ECHO SUPP
 - 2.8.7.2 AUTO SUPP RANGE
 - 2.8.7.3 HOVER LEVEL
 - 2.8.7.4 SHAPER MODE
 - 2.8.8 TVT SHAPER
 - 2.8.8.1 BRKPT. 1-9
 - 2.8.8.2 BRKPT. 10-18
 - 2.8.8.3 BRKPT. 19-27
 - 2.8.8.4 BRKPT. 28-36
 - 2.8.8.5 BRKPT. 37-40
 - 2.8.9 MEAS. VALUES
 - 2.8.9.1 LEVEL MEAS.
 - 2.8.9.2 SPACE MEAS.
 - 2.8.9.3 DISTANCE MEAS.
 - 2.8.9.4 VOLUME MEAS.

3. DIAGNOSTICS

- 3.1 ECHO PROFILE
- 3.2 ELECTRONICS TEMP.
 - 3.2.1 CURR. INTERN. TEMP.
 - 3.2.2 HIGHEST VALUE.
 - 3.2.3 LOWEST VALUE.

4. SERVICE

- 4.1 MASTER RESET
- 4.2 REMAIN. DEV. LIFE
 - 4.2.1 LIFETIME EXPECTE..
 - 4.2.2 TIME IN OPER..
 - 4.2.3 REMAIN. LIFETIM..
 - 4.2.4 REMINDER ACTIV.
 - 4.2.5 REMINDER 1 (REQ)
 - 4.2.6 REMINDER 2 (DEM)

- 4. **SERVICE (cont'd)**
 - 4.2.7 MAINT STAT
 - 4.2.8 ACK STATUS
 - 4.2.9 ACK
 - 4.3 REMAIN. SENS. LIFE
 - 4.3.1 LIFETIME EXPECTE..
 - 4.3.2 TIME IN OPER..
 - 4.3.3 REMAIN. LIFETIM..
 - 4.3.4 REMINDER ACTIV.
 - 4.3.5 REMINDER 1 (REQ)
 - 4.3.6 REMINDER 2 (DEM)
 - 4.3.7 MAINT STAT
 - 4.3.8 ACK STATUS
 - 4.3.9 ACK
 - 4.4 SERVICE SCHED.
 - 4.4.1 SERV. INTERVAL
 - 4.4.2 TIME SINCE LAST
 - 4.4.3 TIME UNTIL NEXT
 - 4.4.4 REMINDER ACTIV.
 - 4.4.5 REMINDER 1 (REQ)
 - 4.4.6 REMINDER 2 (DEM)
 - 4.4.7 MAINT STAT
 - 4.4.8 ACK STATUS
 - 4.4.9 ACK
 - 4.5 CALIB.SCHED.
 - 4.5.1 CALIB. INTERVAL
 - 4.5.2 TIME SINCE LAST
 - 4.5.3 TIME UNTIL NEXT
 - 4.5.4 REMINDER ACTIV.
 - 4.5.5 REMINDER 1 (REQ)
 - 4.5.6 REMINDER 2 (DEM)
 - 4.5.7 MAINT STAT
 - 4.5.8 ACK STATUS
 - 4.5.9 ACK
 - 4.6 MANUF. DATE
 - 4.7 POWERED HOURS
 - 4.8 POWERON RESETS
 - 4.9 LCD FAST MODE
 - 4.10 LCD CONTRAST
 - 4.11 MEM. TEST
- 5. **COMMUNICATION**
 - 5.1 DEVICE ADDRESS
- 6. **SECURITY**
 - 6.1 REMOTE ACCESS
 - 6.1.1 ACCESS CONTROL
 - 6.2 LOCAL ACCESS
 - 6.2.1 WRITE PROTECT
 - 6.2.2 PIN TO UNLOCK
- 7. **LANGUAGE**

Notes

For more information

www.siemens.com/level

www.siemens.com/continuous-weighing

Siemens AG
Industry Sector
1954 Technology Drive
P.O. Box 4225
Peterborough, ON
Canada K9J 7B1

email: techpubs.smpi@siemens.com

www.siemens.com/processautomation

Subject to change without prior notice
A5E32337676 Rev. AA

© Siemens AG 2013



A 5 E 3 2 3 3 7 6 7 6
Printed in Canada