



English  
Dansk  
Deutsch  
Ελληνικά  
Español  
Français  
Italiano  
Nederlands  
Português  
Suomi  
Svenska

# multiranger

100 / 200

**SIEMENS**



# MultiRanger Quick Start Manual

The MultiRanger is a versatile and dependable level-monitoring instrument using advanced ultrasonic techniques. The MultiRanger is available in two models, MultiRanger 100 and MultiRanger 200, and is designed for a variety of applications:

- water and wastewater
- storage tanks, for measuring liquids, slurries, and solids
- hoppers, ore bunkers, flotation cells

## MultiRanger 100

The MultiRanger 100 is a single or dual-point level, one, three, or six relay measurement device. It is equipped with digital communications and offers the latest in echo processing technology and diagnostic features.

## MultiRanger 200

The MultiRanger 200 is a single or dual-point, three or six relay device that offers both level and volume measurement. It has Open Channel Monitoring capabilities, a larger number of advanced pump control algorithms, and is equipped with digital communications. It offers the latest in echo processing technology and diagnostic features.

### Notes:

- This product is intended for use in industrial areas. Operation of this equipment in a residential area may cause interference to several frequency based communications.
- The MultiRanger is to be used only in the manner outlined in this manual, otherwise protection provided by the equipment may be impaired.

This manual outlines the essential features and functions that apply to the MultiRanger 100 and the MultiRanger 200. Features that apply to the MultiRanger 200 are clearly marked.

We strongly advise you to acquire the detailed version of the manual so you can use your device to its fullest potential. The complete manual is available on our Web site:

[www.siemens.com/processautomation](http://www.siemens.com/processautomation).

The printed manual is available from your local Siemens Milltronics representative.

Questions about the contents of this manual can be directed to:

Siemens Milltronics Process Instruments Inc.  
1954 Technology Drive, P.O. Box 4225  
Peterborough, Ontario, Canada, K9J 7B1  
Email: [techpubs.smpi@siemens.com](mailto:techpubs.smpi@siemens.com)

**Copyright Siemens Milltronics  
Process Instruments Inc. 2002.  
All Rights Reserved**

### Disclaimer of Liability

We encourage users to purchase authorized bound manuals, or to view electronic versions as designed and authored by Siemens Milltronics Process Instruments Inc. Siemens Milltronics Process Instruments Inc. will not be responsible for the contents of partial or whole reproductions of either bound or electronic versions.

While we have verified the contents of this manual for agreement with the instrumentation described, variations remain possible. Thus we cannot guarantee full agreement. The contents of this manual are regularly reviewed and corrections are included in subsequent editions. We welcome all suggestions for improvement.

Technical data subject to change.

MILLTRONICS® is a registered trademark of Siemens Milltronics Process Instruments Inc.

## Safety Guidelines

Warning notices must be observed to ensure personal safety as well as that of others, and to protect the product and the connected equipment. These warning notices are accompanied by a clarification of the level of caution to be observed.

**Warning: This product can only function properly and safely if it is correctly transported, stored, installed, set up, operated, and maintained.**

# Specifications

For a complete listing, see the MultiRanger Instruction manual. For Approval information, please refer to the MultiRanger nameplate.

## Power

### AC Version

- 100-230 V AC  $\pm$  15%, 50 / 60 Hz, 36 VA (17W)<sup>1</sup>
- fuse: F3: 2 AG, Slow Blow, 0.375A, 250V

### DC Version

- 12-30 V DC, 20W<sup>1</sup>
- fuse: F3: 2 AG, Slow Blow, 2A, 250V

<sup>1</sup>Power consumption is listed at maximum.

## Installation Conditions

### Altitude

- 2000 m max

### Ambient Temperature

- -20 to +50 °C (-5 to +122 °F)

### Installation Category

- II

### Pollution Degree

- 4

### Range

- 0.3 m (1 ft) to 15 m (50 ft), transducer dependent

## Outputs

### Transducer Drive

- 315 V peak

### mA Analog

#### MultiRanger 100/200:

Single or Dual point versions include two mA outputs.

- 0-20 mA
- 4-20 mA
- 750 ohm maximum
- Resolution of 0.1%
- Isolated

### Relays<sup>1</sup>

- **One:** 1 control
- **Three:** 2 control, 1 alarm control
- **Six:** 4 control, 2 alarm control
- all relays rated 5 A at 250 V AC, non-inductive

### Control Relays

- 1, 2 or 4 Form **A**, **NO** relays (relays numbered 1, 2, 4, 5)

### Alarm Relays

- **0**, **1** or **2** Form **C**, **NO**, or **NC** relay (relays numbered 3, 6)

### Communication

- RS-232 (Modbus RTU and ASCII via RJ-11 connector)
- RS-485 (Modbus RTU and ASCII via terminal blocks)

<sup>1</sup>All relays are certified only for use with equipment that fails in a state at or under the rated maximums of relays.

## Inputs

### mA (analog) (1) [MR 200 only] Discrete (2)

- 0-20 or 4-20 mA, from alternate device, scalable
- 10-50 V DC switching level
- logical 1 = 10 to 50 V DC
- logical 0 = < 0.5 V DC
- 3 mA maximum draw

## Transducers

### Compatible

- Echomax series
- STH series

### Cable (365m Max)

- do not use coaxial cable for transducers
- 2-3 copper conductors, twisted with shield, drain wire, 300Vrms, 0.324 - 0.823 mm<sup>2</sup> (22 - 18AWG), nominal capacitance between adjacent conductors @ 1 kHz = 19pF/ft., nominal capacitance between conductor and shield @ 1kHz = 33 pF/ft. (Belden 8760 is acceptable).
- 365 m maximum

# Installation

## Notes:

- Installation shall only be performed by qualified personnel and in accordance with local governing regulations.
- This product is susceptible to electrostatic shock. Follow proper grounding procedures.



**All field wiring must have insulation suitable for at least 250 V.**



**Hazardous voltage present on transducer terminals during operation.**



**DC terminals shall be supplied from an SELV source in accordance with IEC 1010-1 Annex H.**

- The non-metallic enclosure does not provide grounding between conduit connections. Use grounding type bushings and jumpers.

## Wall Mount Installation

1. Remove the lid screws and open the lid to reveal the mounting screw holes.
  2. Mark and drill four holes in the mounting surface for the screws. (customer supplied).
  3. Fasten with a long screwdriver.
- 
- Cable Entry Locations

### Conduit Cable Entry

1. Remove screws holding motherboard and pull straight out.
2. Drill cable entry holes carefully, leaving room for existing contents.
3. Attach conduits using approved suitably sized hubs for watertight application.
4. Reinstall the motherboard with the mounting screws.

### Exposed Cable Entry (supplied glands)

1. Unscrew glands and attach loosely to enclosure.
2. Thread cables through glands. Keep power cable separate from signal cable.
3. Wire cables to terminal blocks and tighten glands to form a good seal.

**Note:** For conduit locations and assembly for mounting in Class 1, Div. 2 applications, please see Drawing 23650314 in Appendix A.

# Panel Mount Installation

Installing the panel mount unit requires making a cutout in the panel. The cutout template is provided with your unit or may be downloaded from [www.siemens.com/processautomation](http://www.siemens.com/processautomation).

## Panel Mount Dimensions

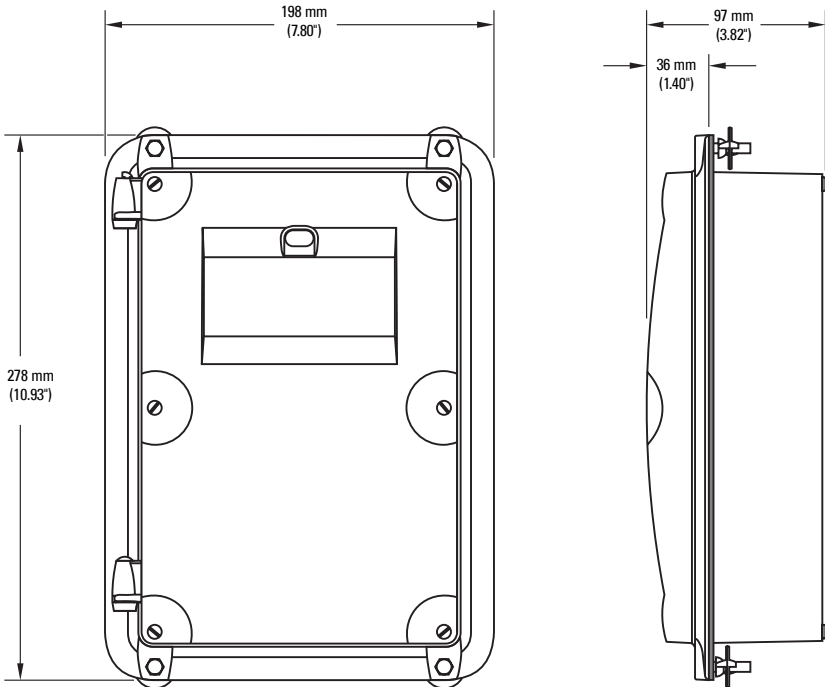

## Mounting the Enclosure

Once cutout is complete and mounting holes are drilled, follow these steps:

1. Remove lid from unit by undoing the six lid screws and lifting it off its hinges.
2. Remove the four screws holding the motherboard to the enclosure.
3. Be careful not to damage the electronics with static electricity. Remove the motherboard from the enclosure by pulling the board straight out.
4. Drill the required cable entry holes. Be sure to compensate for panel door dimensions and make sure conduit holes do not interfere with the lower areas on the terminal block, circuit board, or SmartLinX card.
5. Replace board and fasten the four screws.
6. Place the unit into the panel and insert hexagonal fasteners through bevel holes and predrilled panel holes.
7. Fasten with wingnuts from the rear, and hand tighten.
8. Add conduit or glands and wire as required, then replace the lid.

### Helpful hint:

- Use tape to hold hexagonal heads in holes while attaching wingnuts.

# Wiring

## Notes:

- For complete wiring instructions, please refer to the Instruction Manual.
- Verify that all system components are installed in accordance with instructions.
- Connect all cable shields to the MultiRanger Shield Connections. Avoid Differential ground potentials by not connecting cable shields to ground (earth) anywhere.
- Keep exposed conductors on shielded cables as short as possible to reduce noise on the line caused by stray transmissions and noise pickup.

## Terminal Board

The terminal board on the MultiRanger allows all inputs and outputs to be connected simultaneously.

### Note:

Recommended torque on terminal clamping screws:

- 0.56 – 0.79 Nm (5 – 7 in.lbs)

**Please do not overtighten the screws**

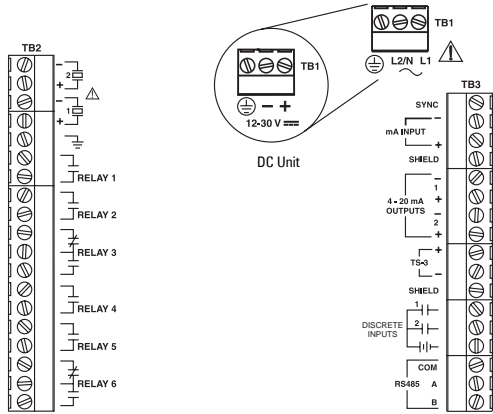

## Transducers



**Warning: Hazardous voltage present on transducer terminals during operation.**

**Run the transducer cable in a grounded metal conduit, separate from other wiring (except TS-3 temperature sensor wiring, if applicable).**

### Notes

- Do not use coaxial cable because of electrical noise interference
- Do not connect the shield and white transducer wires together; wire to separate terminals.
- Disregard transducer manuals recommending these practices

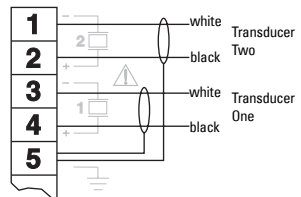

A 0.1  $\mu$ F (100V or greater) capacitor is included with the MultiRanger for retrofitting old MultiRanger Plus installations. Please refer to *General Appendix F—Upgrading* in the complete MultiRanger Instruction Manual for more information.



## Relays

Relay contacts are shown in the de-energized position. All relays are handled identically and can be configured as positive or negative logic using P118 (See Instruction Manual).

### Relay Ratings:

- four Form A, NO relays (1, 2, 4, 5)
- two Form C, NO or NC relays (3,6)
- 5A at 250 V AC, non-inductive

### Relay Function

**Note:** The MultiRanger 100 or 200 can be programmed with relays. The number of relays installed depends on the model. To determine the number of available relays that can be utilized in your MultiRanger 100 or 200, open the lid and count the large white relays to the left of the display. It is important to count the number of on-board relays as the software will allow programming of up to six relays whether they are installed or not.

### Power Failure:

- Relays 1, 2, 4, and 5 are NO and will fail in the normal state
- Relays 3 and 6 are wired either NO or NC, and will fail in their de-energized states.

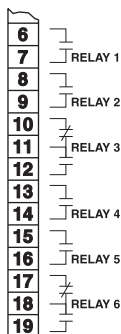

## mA Output

For more information, consult the mA output parameters (P200 to P219) in the parameter reference section of the Instruction Manual.

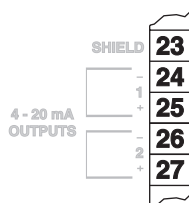

## Power

### Important!

- Before applying power to the MultiRanger for the first time, ensure any connected alarm/control equipment is disabled until satisfactory system operation and performance is verified.
- Please make sure unit is connected to a reliable ground.

### Notes for AC power connections

- The equipment must be protected by a 15 A fuse, or circuit breaker in the building installation.
- A circuit breaker or switch in the building installation, marked as the disconnect switch, must be in close proximity to the equipment and within easy reach of the operator.

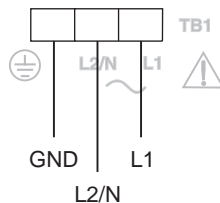



# Operating the MultiRanger

The MultiRanger has two modes of operation PROGRAM and RUN. PROGRAM mode lets you configure the MultiRanger to fit your application.

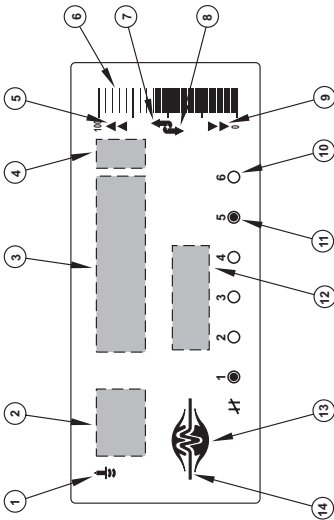
## MultiRanger Display and Indicator Functions



RUN Mode	PROGRAM Mode
1 index type	index type
2 index	index
3 primary reading	parameter value
4 units	units
5 hi and hi hi alarm designation	auxiliary function
6 level display	n/a
7 filling display	scroll access tag
8 emptying display	scroll access tag
9 lo and lo lo alarm designation	n/a
10 relay # programmed flashing = unavailable	relay # programmed flashing = unavailable
11 relay # activated	relay # activated
12 auxiliary reading	parameter number
13 normal operation: 	n/a
14 failsafe operation: 	n/a



## Programming

The MultiRanger is programmed by setting its parameters to match your specific application. In PROGRAM mode, these parameter values are changed to set operating conditions. The MultiRanger is programmed with the hand programmer. Point to the infrared port above the display and press keys.





### Activating the MultiRanger

All the instructions assume that the MultiRanger is activated.

**Note:** On powering up, a single point unit displays distance; a dual point unit displays **OFF**.

1. Power the MultiRanger.
2. Point the programmer at the unit and press PROGRAM .
3. Press DISPLAY .

### Changing Parameters

1. In RUN mode, press PROGRAM . Press DISPLAY  to put the unit into PROGRAM mode.
2. Press DISPLAY  to select the Parameter Number field.
3. Enter the Parameter Number. After the third digit is entered, the parameter value is shown.
4. Enter the new value, and press ENTER .

# Quick Start Parameters

## Notes:

- P000 locks the unit, The unlocking value is 1954. All other values lock the unit.
- Defaults are shown with an \*

**P001 Operation:** Sets the type of measurement required for the application.

Primary Index	Single Point Model		Dual Point Model
	Global		Transducer
Values	0		Out-of-service
	1		Level-how full the vessel is (MR200: volume - P050)
	2		Space-how empty the vessel is (MR200: ullage - P050)
	3	*	Distance (transducer to material)
	4		DPD – dual point difference [MR200]
	5		DPA – dual point average [MR200]
	6		OCM – open channel flow rate [MR200]
7		Pump Totalizer-total pumped volume [MR200]	

**P002: Material:** Measures material type. Liquid, may involve solids.

Primary Index	Single Point Model		Dual Point Model
	Global		Transducer
Values	1	*	Liquid or horizontal solid surface
	2		Solid or angled surface

**P003 Maximum Process Speed:** Determines level change reaction.

Primary Index	Transducer		
Values	1		Slow (0.1 m/min)
	2	*	Medium (1 m/min)
	3		Fast (10 m/min)

**Note:** Please refer to the Instruction Manual to set up inputs, alarms and controls, communications, and other functionality.

**P004 Transducer:** Specifies transducer.

Primary Index	Single Point Model		Dual Point Model
	Global		Transducer
Values	0	*	No transducer attached (preset for Dual Point)
	1		ST-25
	2		ST-50
	100		STH
	101		XCT-8
	102	*	XPS-10 (preset for Single Point Model)
	103		XCT-12
	104		XPS-15
	112		XRS-5
	250		mA input [MR200]

**P005 Units:** Specifies units used for dimensional values.

Primary Index	Global		
Values	1	*	Meters
	2		Centimeters
	3		Millimeters
	4		Feet
	5		Inches

**P006 Empty:** Distance in Units (P005) from transducer face to process empty point.

Primary Index	Transducer	
Values	Range: 0.000 to 99.000 m (or equivalent depending on units)	
	Preset: 5.000 m (or equivalent depending on units)	
Alters	• P007 Span	
Altered By	• P005 Units	

**P007 Span:** Sets range levels to be measured.

Primary Index	Level	
Values	Range: 0.000 to 99.000 m (or equivalent depending on units)	
	Preset: based on Empty (P006)	

# Troubleshooting

Symptom	Cause	Action
Display blank, transducer not pulsing.	No power.	Check power supply, wiring, or power fuse.
No response to programmer.	Obstructed infrared interface, defective programmer.	Check programmer usage: 15 cm (6") from faceplate pointed at upper target.
Displays <b>Short</b> and <b>tb:(#)</b>	Short circuited transducer cable, or defective transducer at indicated terminal block number.	Repair or replace as necessary.
Displays <b>Open</b> and <b>tb:(#)</b>	Transducer not connected or connection reversed.	Check connection to displayed terminal blocks
	Open circuited transducer cable, or defective transducer at indicated terminal block number.	Repair or replace as necessary.
Displays <b>LOE</b>	Weak or non-existent echo.	Relocate and/or re-aim transducer.
		Proceed to Measurement Difficulties.
Displays <b>Error</b> and <b>tb:(#)</b>	Wrong transducer selected (P004).	Re-enter correct transducer type.
	Transducer connected in "two wire" method.	Do not tie white and shield together, use all three terminal blocks.
	Transducer connected backwards.	Reverse black and white wires on terminal block.
Displays <b>EEEE</b>	Value too large to display in 4 or 5 characters.	Select larger Units (P005), or lower Convert Reading (P061).
Reading fluctuates while material level is still (or vice versa).	Incorrect measurement stabilization.	Alter Maximum Process Speed (P003) or damping (P704).
Reading is fixed, regardless of the actual material level.	Transducer acoustic beam obstructed, standpipe too narrow, or transducer ringing (reads over 100%).	Relocate and / or re-aim transducer at material level or object.
		Go to Measurement Difficulties below.
		See also: Transducer Ringing.
Material level reported is always incorrect by the same amount.	Incorrect Empty (zero) reference for level operation (P001 = 1).	See Empty (P006), Reading Offset (P063), Offset Calibration (P650), and Offset Correction (P652).
Measurement accuracy improves as level nears transducer.	Incorrect Sound Velocity used for distance calculation.	Use transducer with built-in temperature sensor or a TS-3 temperature sensor.
		See Sound Velocity.
Reading is erratic, with little or no relation to material level.	True echo too weak or wrong echo being processed.	Relocate and / or re-aim transducer.
		Check noise parameters.

**Note:** Please refer to the complete Instruction Manual for further information.

# Hazardous Area Installations

**Note:** The following instructions apply only to the MultiRanger 100/200, product number 7ML5033.

## Panel mount:

### **Instructions specific to hazardous area installations (Reference European ATEX Directive 94/9/EC, Annex II, 1/0/6)**

The following instructions apply to equipment covered by certificate number SIRA06ATEXT9163X:

1. For use and assembly, refer to the main instructions.
2. The equipment is certified for use as Category 3D equipment.
3. The equipment may be used in hazardous zone 22 except for conductive dusts (e.g., metal or carbon dusts).
4. This equipment has a maximum surface temperature of T75 °C (in a +50 °C ambient). Refer to the applicable Code Of Practice for selection of this equipment with respect to specific dust ignition temperatures.
5. The equipment is certified for use in an ambient temperature range of -20 to +50 °C.
6. Any cable or conduit entries must meet the requirements of European Directive 94/9/EC for Group II, Category 3D and maintain the overall IP rating of the enclosure.
7. Cable should be selected in accordance with the applicable Code of Practice and such that its insulation can withstand the maximum surface temperature of the enclosure (T75 °C).
8. The equipment has not been assessed as a safety related device (as referred to by Directive 94/9/EC Annex II, clause 1.5).
9. Installation and inspection of this equipment shall be carried out by suitably trained personnel in accordance with the applicable code of practice (EN 60079-14 and EN 60079-17 in Europe).
10. Repair of this equipment shall be carried out by suitably trained personnel in accordance with the applicable code of practice (e.g. EN 60079-19 within Europe).
11. Components to be incorporated into or used as replacements in the equipment shall be fitted by suitably trained personnel in accordance with the manufacturer's documentation.
12. Manual override can be accomplished by using the disconnect switch provided in the building installation.

**Wall mount:****Instructions specific to hazardous area installations (Reference European ATEX Directive 94/9/EC, Annex II, 1/0/6)**

The following instructions apply to equipment covered by certificate number SIRA06ATEXT9163X:

1. For use and assembly, refer to the main instructions.
2. The equipment is certified for use as Category 3D equipment.
3. The equipment may be used in hazardous zone 22.
4. This equipment has a maximum surface temperature of T75 C (in a +50 °C ambient). Refer to the applicable Code Of Practice for selection of this equipment with respect to specific dust ignition temperatures.
5. The equipment is certified for use in an ambient temperature range of -20 to +50 °C.
6. Any cable or conduit entries must meet the requirements of European Directive 94/9/EC for Group II, Category 3D and maintain the overall IP rating of the enclosure.
7. Cable should be selected in accordance with the applicable Code of Practice and such that its insulation can withstand the maximum surface temperature of the enclosure (T75 °C).
8. The equipment has not been assessed as a safety related device (as referred to by Directive 94/9/EC Annex II, clause 1.5).
9. Installation and inspection of this equipment shall be carried out by suitably trained personnel in accordance with the applicable code of practice (EN 60079-14 and EN 60079-17 in Europe).
10. Repair of this equipment shall be carried out by suitably trained personnel in accordance with the applicable code of practice (e.g. EN 60079-19 within Europe).
11. Components to be incorporated into or used as replacements in the equipment shall be fitted by suitably trained personnel in accordance with the manufacturer's documentation.
12. Manual override can be accomplished by using the disconnect switch provided in the building installation.