

NOTES:

- 1) DIMENSIONS ARE mm, () DENOTES INCHES.
- 2) ----- DENOTES WIRING BY CUSTOMER. ALL WIRING MUST BE DONE IN CONJUNCTION WITH APPROVED CONDUIT, FITTINGS, AND BOXES ALSO IN ACCORDANCE WITH ALL GOVERNING REGULATIONS.
- 3) RUN THE TRANSDUCER CABLE IN A GROUNDED METAL CONDUIT, SEPARATE FROM OTHER WIRING. (EXCEPT TS-3 IF APPLICABLE) DO NOT USE A COAXIAL TRANSDUCER CABLE EXTENSION. DO NOT CONNECT THE SHIELD AND WHITE TRANSDUCER WIRES TOGETHER. REFER TO DETAIL 'A' FOR TRANSDUCER CABLE EXTENSIONS.
- 4) ONLY TS-3 TEMP. SENSORS ARE TO BE USED. DO NOT JUMPER TERMINALS IF TS-3 IS NOT USED.
- 5) WHEN MOUNTING TWO OR MORE UNITS IN THE SAME AREA, SYNCHRONIZE THE UNITS BY INTERCONNECTING THE SYNC TERMINALS. (TB3 20 - SYNC).
- 6) REFER TO SPECIFIC SMARTLINX MANUAL IF MODULE IS USED.
- 7) REFER TO INSTRUCTION MANUAL FOR SPECIFIC CONNECTION OF EACH TYPE OF COMMUNICATIONS. MAXIMUM DISTANCE BETWEEN UNITS AND CUSTOMER DEVICE IS 3 m (9.8 FT) FOR RS-232 AND 1200 m (4000 FT) FOR RS-485.
- 8) FOR FURTHER INFORMATION REFER TO THE APPROPRIATE INSTRUCTION MANUAL OR CONTACT THE NEAREST SIEMENS MILLTRONICS REPRESENTATIVE.

SUITABLE LOCATION FOR CONDUIT ENTRANCES USE WATER TIGHT CONDUIT HUBS TO MAINTAIN THE ENCLOSURE RATING

4.3 mm (0.17") DIA. MOUNTING HOLES (4 PLACES)

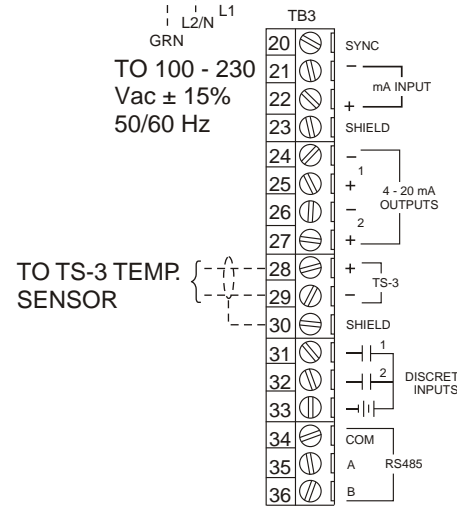
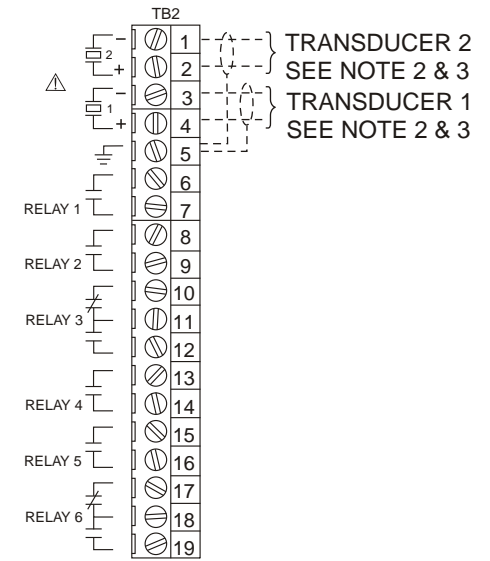
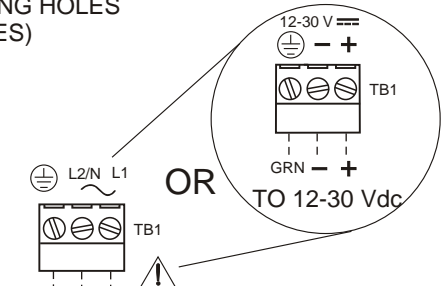

TO TS-3 TEMP. SENSOR

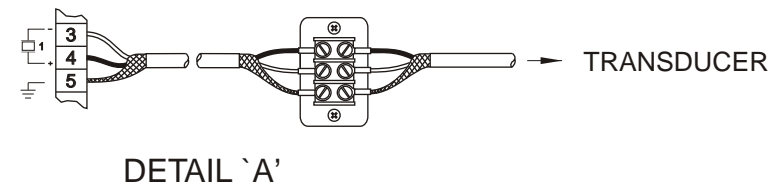

WHEN INSTALLING A NEW SYSTEM IT IS RECOMMENDED USING SCREENED, TWISTED PAIR CABLE, IF AN EXTENSION IS REQUIRED.

| | | | | | | |
|--|---------------|---------------|----------------------------|---|-------------------|--------------|
| USE DIMENSIONS ONLY - DO NOT SCALE | | 0 | FOR CONSTRUCTION | RPC | SM | DEC 20/01 |
| DIMENSIONS ARE IN INCHES | | Rev. | Revision / ECN Description | Drawn | Appr. | Date |
| <p>Third Angle Projection</p> | Product Group | ULTRASONICS | | Tolerance Unless Otherwise Noted: UOS | Scale: | Size: |
| | Date: | 20 / DEC / 01 | | 1 Place Decimal ± 0.03 2 Place Decimal ± 0.01 3 Place Decimal ± 0.002 | Angles: ± 0.5° | NONE |
| <p>CONFIDENTIAL IMPORTANT NOTICE</p> <p><small>THIS DOCUMENT REMAINS THE PROPERTY OF SIEMENS MILLTRONICS AND IS SUBJECT TO RECALL. IT MAY NOT BE COPIED, AND IS ISSUED AND CAN BE UTILIZED ONLY FOR SUCH LIMITED PURPOSES AS MAY SPECIFICALLY HAVE BEEN AUTHORIZED BY SIEMENS MILLTRONICS. IT IS TO BE MAINTAINED CONFIDENTIAL, SINCE IT MAY CONTAIN PROPRIETARY INFORMATION AND TRADE SECRETS OF SIEMENS MILLTRONICS OR OTHERS. THE ITEMS DEPICTED MAY THEMSELVES BE THE SUBJECT OF PATENTS, INDUSTRIAL DESIGN REGISTRATIONS OR COPYRIGHTS OF SIEMENS MILLTRONICS OR OTHERS, AND THE ISSUE OF THIS DRAWING DOES NOT IMPLY ANY LICENSE UNDER ANY SUCH RIGHTS.</small></p> <p><small>COPYRIGHT SIEMENS MILLTRONICS PROCESS INSTRUMENTS INC. ALL RIGHTS RESERVED</small></p> | Drawn: | R. CLYSDALE | | TITLE: MULTIRANGER 100 / 200 OUTLINE AND CONNECTION DIAGRAM | | |
| | Checked: | R. NUNES | | | | |
| | Approved: | S. MILLIGAN | | DRAWING No: 23650304 | | |
| | Location: | PETERBOROUGH | | | | |
| SIEMENS MILLTRONICS PROCESS INSTRUMENTS INC. Peterborough, Ontario, Canada | | File No. | 2365030400 | Plot at: | 1 : 1 | Sheet 1 Of 1 |