Installation guide 854 XTG Level Gauge



July 2008
Part no. 4416.276
Rev. 5



Enraf B.V.
P.O. Box 812
2600 AV Delft
Netherlands

Honeywell Enraf

Tel. : +31 15 2701 100
Fax : +31 15 2701 111
E-mail : enraf-nl@honeywell.com
Website : <http://www.honeywellenraf.com>

Preface

The Honeywell Enraf 854 XTG is a servo gauge which measures the liquid level and can also be programmed to measure two additional interface levels.

This installation guide is intended for technicians involved with the mechanical and electrical installation of the Honeywell Enraf 854 XTG Servo Gauge.

EC declaration of conformity

Refer to the EC declaration of conformity, shipped with the instrument.

Note:

All connections to the instrument must be made with shielded cables with exception of the mains, alarm outputs and Honeywell Enraf field bus cable. The shielding must be grounded in the cable gland on both ends of the cable.

Legal aspects

The mechanical and electrical installation shall only be carried out by trained personnel with knowledge of the requirements for installation of explosion-proof equipment in hazardous areas.

The information in this installation guide is the copyright property of Enraf B.V., Netherlands. Enraf B.V. disclaims any responsibility for personal injury or damage to the equipment caused by:

- Deviation from any of the prescribed procedures;
- Execution of activities that are not prescribed;
- Neglect of the general safety precautions for handling tools, use of electricity and microwave radiation.

The contents, descriptions and specifications in this installation guide are subject to change without notice. Enraf B.V. accepts no responsibility for any errors that may appear in this manual.

Additional information

Please do not hesitate to contact Honeywell Enraf or its representative if you require additional information.

Safety

Safety aspects of 854 XTG

Warning

Do not use the instrument for anything else than its intended purpose.

The housing of the 854 XTG is explosion-proof:

- II 1/2 G EEx d [ib/ia] IIB T6 acc. to KEMA 02ATEX2193 X certified by KEMA, Netherlands
- Class I, Division 1, Groups B, C & D, in acc. to ANSI/NFPA No. 70, certified by Factory Mutual Research USA (FM no.: 5Y2A9.AX).

Environmental conditions for the 854 XTG are:

| | | |
|---------------------|---|--|
| ambient temperature | : | -40 to + 65 °C (-40 to +149 °F) |
| operating pressure | : | max. 6 bar |
| relative humidity | : | 0 - 100 % |
| ingress protection | : | IP65 (NEMA 4), suitable for outdoor installation |

The drum compartment, which is in contact with the tank atmosphere, is separated from electronic compartment. A magnetic coupling transfers the drum movement (hence, displacer movement) to electronic compartment.

Wiring for intrinsically safe options, such as temperature or pressure measurement, is fed via two separate cable entries.

The covers of electronic and terminal compartment are locked by means of a setscrew, which prevents accidental opening.

Warning

Improper installation of cable glands, conduits or stopping plugs will invalidate the Ex approval of the 854 XTG.

Personal safety

The technician must have basic technical skills to be able to safely install the equipment. When the 854 XTG is installed in a hazardous area, the technician must work in accordance with the (local) requirements for electrical equipment in hazardous areas.

Warning

In hazardous areas it is compulsory to use personal protection and safety gear such as: hard hat, fire-resistive overall, safety shoes, safety glasses and working gloves.

*Avoid possible generation of static electricity.
Use non-sparking tools and explosion-proof testers.*

*Make sure no dangerous quantities of combustible gas mixtures
are present in the working area.*

Never start working before the work permit has been signed by all parties.

*Pay attention to the kind of product in the tank. If any danger for health,
wear a gas mask and take all necessary precautions.*

Safety conventions

“**Warnings**”, “**Cautions**” and “**Notes**” are used throughout this installation guide to bring special matters to the immediate attention of the reader.

- A **Warning** concerns danger to the safety of the technician or user;
- A **Caution** draws the attention to an action which may damage the equipment;
- A **Note** points out a statement deserving more emphasis than the general text, but not requiring a “Warning” or a “Caution”.

General precautions

Caution

During transport of the gauge the motor lock block should be locked.
This is for protection of the weighing system.

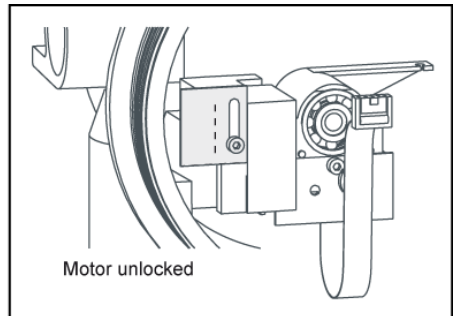
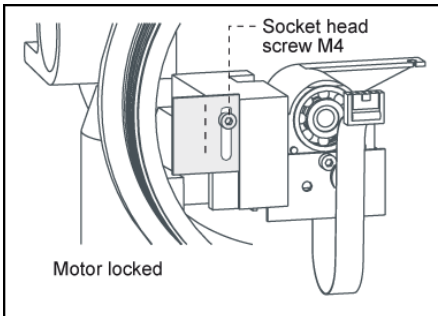

Figure 1 Motor (un)locking

Tools required:

Hex Allen-key for screw M4 (length minimal 22 mm)

Tommy bar

part No.: 6121.030

part No.: 2998.024

Caution

The box in which the 854 arrives also contains the measuring drum. This is a precision measuring device and shall only be installed by a qualified commissioning engineer.
Accurate measurement requires an undamaged and clean drum.

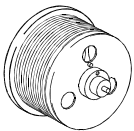

Treat this drum with care !

Mechanical installation

Note:

The entire installation procedure shall be in accordance with national, local and company regulations.

Preparation for transportation of the gauge

Caution

Do not transport the instrument with the motor unlocked. Refer to figure 1 for motor locking.

Drum should be transported in original protective box. Drum and displacer shall only be installed by a qualified commissioning engineer.

Process connection

The flange of the 854 XTG is standard 2" 150 lbs, ff, acc. to ANSI B16.5. Select gasket that is suitable for flange type, maximum pressure and the products to be stored.

Caution

Verify that tank or drum compartment is depressurized before opening tank or drum compartment cover of 854 XTG.

The 854 XTG can be adapted to various process connection flanges via the adapter/calibration chamber as specified in Appendix B. Verify that maximum working pressure of adapter/calibration chamber complies with pressure in your tank.

Note:

When using 854 XTG on pressurized tank, it is recommended to install a suitable valve between tank and 854 XTG to isolate the instrument from the process when required. The valve shall have an opening large enough to feed through the displacer.

Orientation of 854 XTG gauge on tank

Mount the gauge in one of the following two ways.

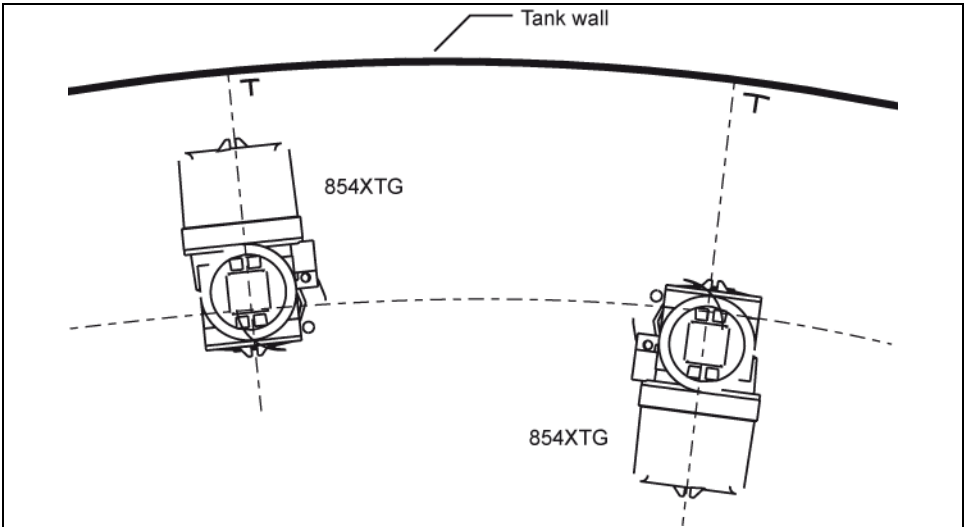

Figure 2 Orientation of the gauge on tank

On a stilling well or guide pole the orientation of the gauge may be chosen freely.

Note:

The weight of the 854 XTG is 16 kg (35 lbs).

Bolts

Secure the gauge adapter by using appropriate (stud) bolts. *)

| Flange type | Number of (stud) bolts | Diameter x minimum length |
|-------------|------------------------|---|
| 2" 150 lbs | 4 stud bolts | M16 x 80 ($\frac{5}{8}$ " x 3 $\frac{1}{4}$ ") |
| 6" 150 lbs | 8 bolts | M20 x 80 ($\frac{3}{4}$ " x 3 $\frac{1}{4}$ ") |
| 6" 150 lbs | 8 stud bolts | M20 x 110 ($\frac{3}{4}$ " x 4 $\frac{3}{8}$ ") |

*) ref. to DIN 2527, ANSI B16.5.

Grounding

Warning

For proper grounding of the 854 XTG, install a copper strip under one of the flange bolts for each flange.

Place shark rings between flange and strip (figure 3).

Note:

Also in case of tanks with cathodic protection, the 854 XTG **must** be grounded to the tank.

Cathodic protection can be maintained by isolating the cabling screen/armouring or conduit.

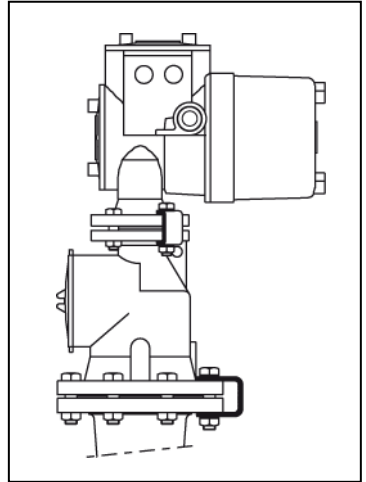

Figure 3 Example of flange ground

Electrical installation

The entire electrical installation shall be in accordance with International Standard IEC 79-14 for electrical equipment to be installed in hazardous areas.

Warning

*Make sure that all power to the instrument is switched off before opening the cover of the electronic and terminal compartment.
Failure to do so may cause danger to persons or damage the instrument.
All covers of the 854 XTG **must** be closed before switching on the power.*

Caution

Before opening the electronic and terminal compartment cover, loosen the setscrews which locks the covers with Allen key 2.5 mm:

*Setscrew 'A': for electronic compartment cover;
Setscrew 'B': for terminal compartment cover.*

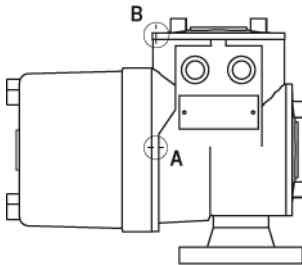

Figure 4 Setscrews locking the covers

Caution

*Do not damage the thread of the covers and instrument and keep the thread free of dirt.
After opening, grease it lightly with anti seize grease.*

*When closing, never tighten the covers before the threads are properly engaged.
The covers should be turned counter-clockwise until the thread "clicks" in place,
then turn clockwise until the covers are fully closed.*

After closing the covers, do not forget to lock it with the setscrew.

Preparing the gauge for electrical installation

Check the mains voltage on the label of 854 XTG. Please contact Honeywell Enraf or its representative if mains setting does not comply with local mains voltage.

Power rating: 25 VA; frequency: 50 - 60 Hz ($\pm 10\%$); $I_{\max} = 2$ A. Allowed supply variations: -20% to +10%, for 230 Vac only: $\pm 15\%$. Install an explosion-proof mains switch in the mains supply cable to each 854 XTG. Specify which switch you need to operate the 854 XTG.

External fusing

The 854 XTG is internally fused on secondary side of transformer (fuses are located on the GPS board). Therefore, external fuses must be installed in the mains supply cable to each 854 XTG.

| Mains voltage | Fuse value (in accordance to IEC 127-2-3) |
|--------------------|---|
| 220 Vac or 230 Vac | 315 mA slow |
| 110 Vac or 130 Vac | 630 mA slow |
| 65 Vac | 1 A slow |

Cable glands / conduit

Cable glands:

The 854 XTG requires explosion-proof (Ex-d) cable glands.

Note:

Mount the cable glands according to the supplier's instructions.

Conduit:

If the 854 XTG is installed in a hazardous area, threaded rigid metal conduit or threaded steel intermediate metal conduit shall be used.

Note:

*If the 854 XTG is installed in a hazardous area, stopper boxes **must** be applied within 18 inches (0.45 m) from the 854 XTG to seal the cabling in the conduit.*

Depending on the wiring configuration, one to four $\frac{3}{4}$ " NPT threaded cable glands (or rigid conduits) may be required with the 854 XTG.

Note:

Seal unused cable inlets with an approved $\frac{3}{4}$ " NPT stopping plug.

Warning

Improper installation of cable glands, conduit or stopping plugs will invalidate the Ex approval of your 854 XTG.

Grounding

The 854 XTG housing should be properly grounded to the ground reference (generally the tank). This is a safety grounding requirement. Grounding can be performed by copper strips across the flanges (refer to section Grounding at mechanical installation), or by a ground wire. With last mentioned method, use one of the external ground terminals of the 854 XTG.

Note:

Grounding shall be performed in accordance with local regulations.

Caution

Safety depends on proper grounding. Check the resistance of the ground connection directly after installation. The measured ground resistance shall be below the maximum prescribed by local grounding requirements.

Warning

When measuring the ground resistance, use a suitable explosion-proof tester.

Lay-out terminal compartment

The terminal compartment of the 854 XTG is divided in a non-intrinsically safe part and an intrinsically safe part.

Cable entries are all $\frac{3}{4}$ " NPT.

The non-intrinsically safe cabling may only enter at the two left hand side cable entries (Figure 5).

Warning

Only open the terminal compartment cover (top cover) when the power is switched off.

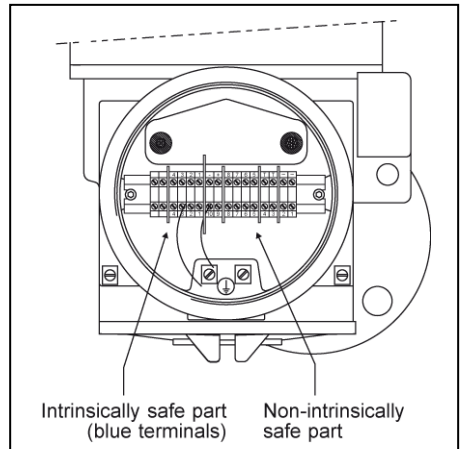

Figure 5 Terminal compartment 854 XTG

Non-intrinsically safe cabling

Mains cabling : Must be suitable for the 854 XTG power rating and, moreover, approved for the use in hazardous areas.

Honeywell

Enraf field bus : One twisted pair cable is recommended. $R_{max} = 200 \Omega / \text{line}$; $C_{max} = 1 \mu\text{F}$.
 Maximum length: 10 km.
 Honeywell Enraf field bus lines may be interchanged. If local regulations allow, mains and Honeywell Enraf field bus lines may share one cable. Mind the isolation voltage of the cores in the cable; refer to the International Standard IEC 61010-1.

Note:

If a quad cable is used and all four cores are twisted together, use two opposite cores for Honeywell Enraf field bus lines and the two others for mains.

Relay outputs : Option. The relay output contacts are potential free. Contact rating:
 $U_{max} = 50 \text{ Vac}$ or 75 Vdc ; $I_{max} = 3 \text{ A}$ non-inductive. Mind the isolation voltage of the cores in the cable; refer to the International Standard IEC 61010-1.

Analog output: : Option. Use shielded cable. External supply voltage: 12 to 64 Vdc
 Refer to figure 7.

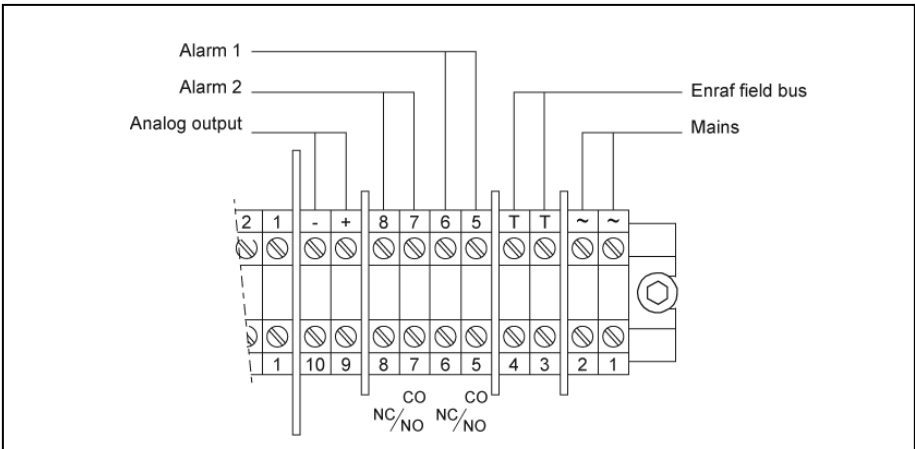

Figure 6 Non-intrinsically safe connections

When the voltage exceeds 30 Vdc, an additional resistor is required.

The permitted operational areas are shown in figure 7.

Operational area 1 represents the area of operation without the need for an external loop resistance.

Operational area 2 shows the area where a resistance is required.

The power rating of the external resistor depends on the value of the resistor.

We recommend 1 W / kΩ.

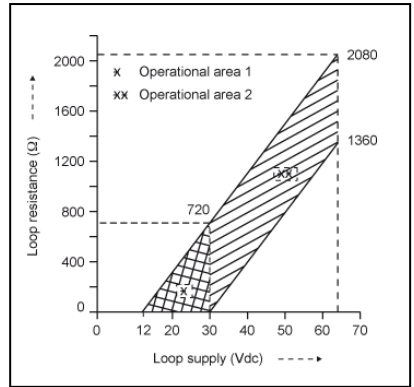

Figure 7 Selecting the external loop resistor

Optional RS communication connections

For the cable connections of the mains and alarm contacts, refer to previous section.

Caution
Keep the RS-232C / RS-485 lines as short as possible.

- RS-232C: Cable requirements: maximum length 15 metres (50 ft); twisted and shielded.
- RS-485: Cable requirements: maximum length 1200 metres (3900 ft); twisted and shielded.

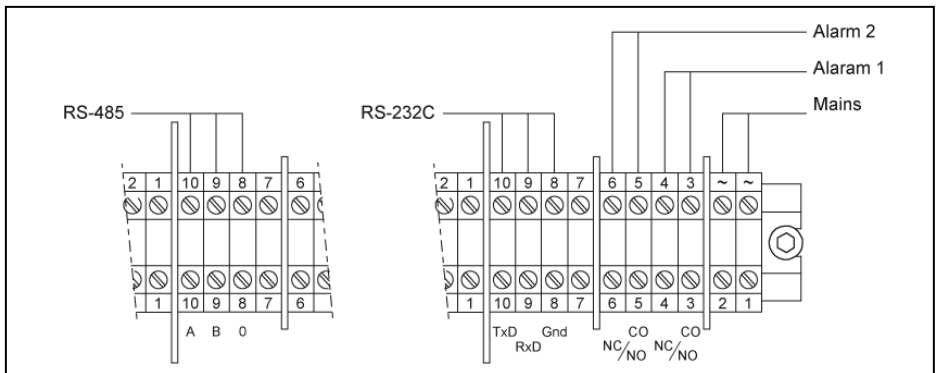

Figure 8 RS-232C / RS-485 connections

Intrinsically safe options

The cables for the intrinsically safe options shall only be fed through the cable entries at the side of the intrinsically safe (blue) terminals. Blue marked cables are recommended for the intrinsically safe options.

Caution

The intrinsically safe options described in this section are explosion-proof certified. Make sure that the certificate of approval is available on site and act in accordance with the instructions as given in the approval certificate.

Caution

Intrinsically safe wiring shall be separated from all other wiring. Cable lay-outs shall be in accordance with local regulations.

Note:

*The shield of the intrinsically safe cable shall **not** be connected inside the 854 XTG housing. Connect the shield of the cable externally in the cable gland at both ends of the cable.*

Device

Cable requirements

| | |
|---|---|
| Spot temperature element | : Shielded; $R_{\max} = 12 \Omega / \text{line}$. |
| Average temp. element (combined water probe) | : Twisted pair and shielded; $R_{\max} = 25 \Omega / \text{line}$. Wiring between the 854 XTG and 762 VITO must be protected with EMC shielded conduit. Same conditions for connection to 862 MIR. |
| Pressure transmitters | : Twisted pair and shielded; $R_{\max} = 25 \Omega / \text{line}$ (only pressure transmitters with HART [®] protocol). Pressure transmitter P1 is the bottom transmitter (measures liquid head) and P3 is the top transmitter (measures vapour pressure). |

Note:

If pressure transmitters are connected to HART input 2, it must be verified that the maximum values for current and power of the HCU option board HART input 2 circuit are not exceeding the maximum values of the connected pressure transmitters. Refer to Appendix C.

If the values of the HART input 2 circuit are too high, then connect the pressure transmitters to HART input 1 and the 762 VITO Interface to HART input 2 (only possible when HART input 1 is available!).

Device Cable requirements

977 Tank Side Indicator : Twisted pair and shielded; $R_{max} = 5 \Omega$ / line; maximum cable length 50 m (160 ft).

Water bottom probe (no VITO water sensor) : Twisted pair and shielded; $R_{max} = 25 \Omega$ / line (only with HART[®] protocol).

Note:

If also pressure transmitters are connected, use a junction box for parallel connection of the pressure transmitters and water bottom probe.

Maximum number of i.s. terminals is 6 (refer to figure 9). Depending on the installed option(s), some of the i.s. terminals are not present. Valid combinations of i.s. options are:

| Sales code position 4 | Optional function(s) | Terminals |
|-----------------------|--|----------------------|
| B | Spot temperature Pt100 (+ 977 TSI) | 1, 2, 3 (+ 7, 8) |
| C, W, X | 762 VITO Interface (+ 977 TSI) | 3, 4 (+ 7, 8) |
| J | 762 VITO Interface + HART [®] device(s) (+ 977 TSI) | 3, 4 + 5, 6 (+ 7, 8) |
| U | Spot temperature Pt100 + HART [®] device(s) | 1, 2, 3 + 5, 6 |

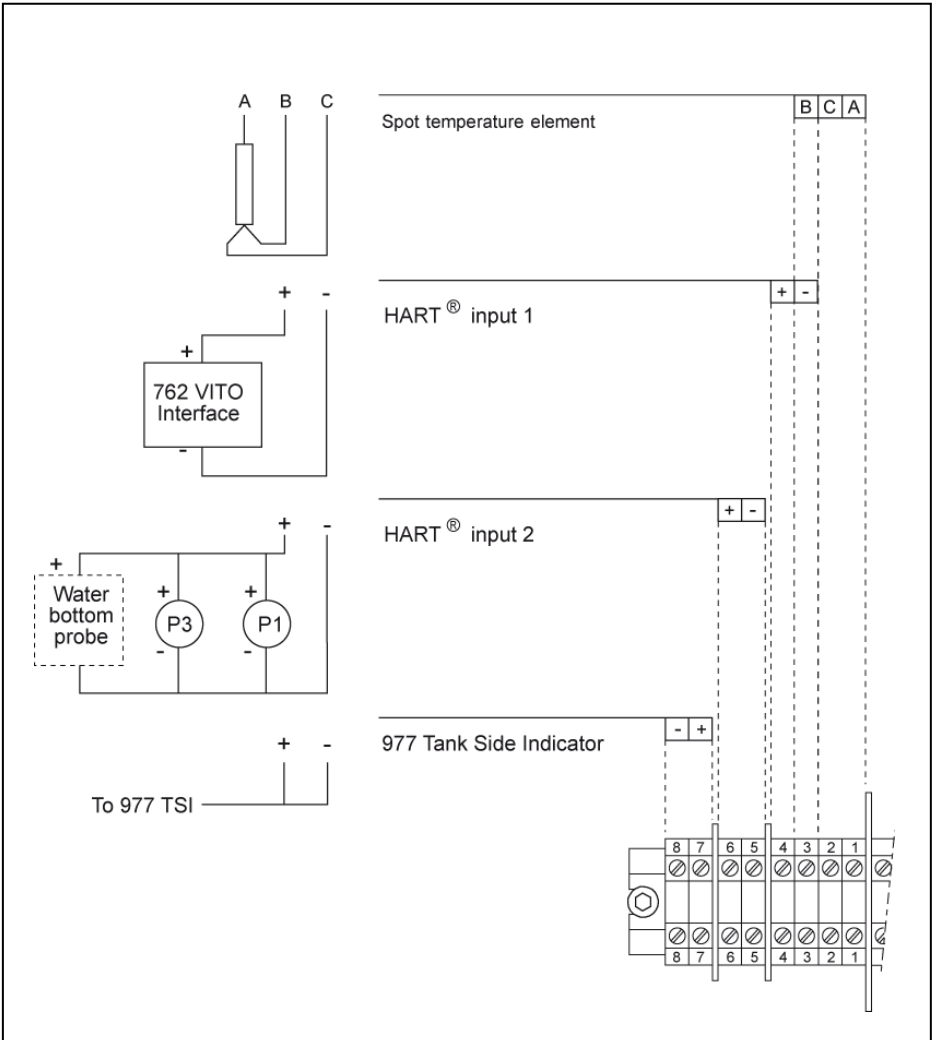
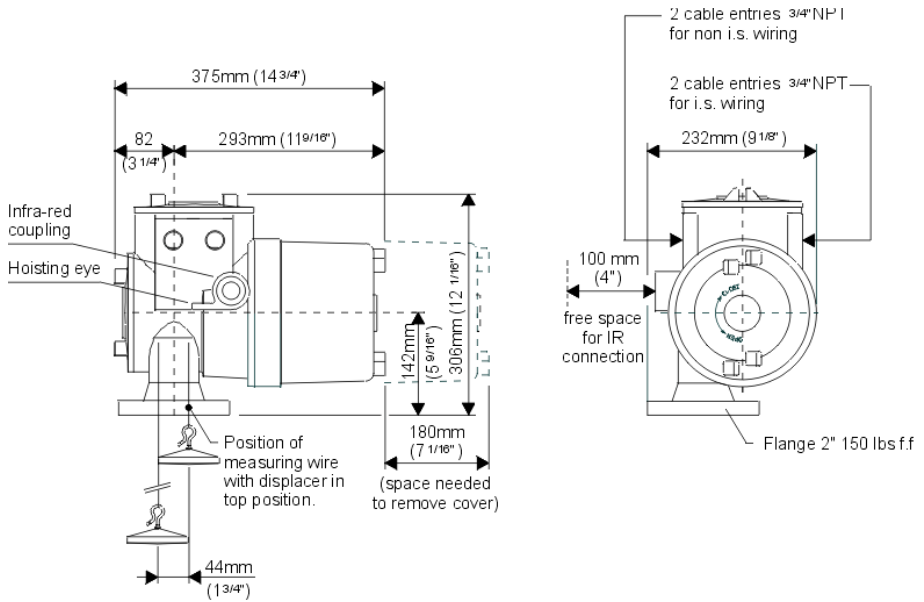

Figure 9 Intrinsically safe connections with HCU option board

Appendix A Dimensions



Material : Aluminium
 Total weight : 16 kg (35.3 lbs)

Appendix B Available adapters

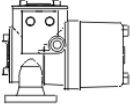
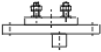
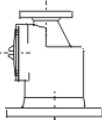
| Orientation | Specifications |
|---|--|
|  | <p>Orientation of adapters, reducers and calibration chambers with regard to the 854 XTG</p> <p>Asymmetrical adapters must be mounted in the right way with respect to the 854 XTG in order to prevent malfunctioning of the gauge.</p> <p>For symmetrical adaptors the orientation is insignificant</p> |
|  | <p>Flange adapter</p> <p>2" to 6" 150 lbs (aluminium 3.2371) Height: 48 mm (17/8") Part no.: 0815.092</p> |
|  | <p>Calibration adapter</p> <p>2" to 6" 150 lbs ff (aluminium 3.2371) Height: 307 mm (12 1/16") Part no.: 0815.091</p> <p>2" to 8" 150 lbs ff (aluminium 3.2371) Height: 307 mm (12 1/16") Part no.: 0815.096</p> |

Appendix C ATEX approval

The terminal compartment of the 854 XTG level gauge has been ATEX approved as explosion proof. Hence, explosion-proof EEx d approved glands or conduit are to be used.

Connection requirements of optional boards

The identification label on the 854 XTG indicates whether your instrument is equipped with an optional board with intrinsically safe measuring circuits.

XPU-2 board (i.s. option), [EEx ib] IIB

Output circuit for 977 TSI:

| | | |
|-----------------------------------|---|----------------------------------|
| Max. values | : | U = 21 V, I = 395 mA, P = 1.41 W |
| Max. permissible ext. inductance | : | 0.8 mH |
| Max. permissible ext. capacitance | : | 1.27 μ F |

HCU option board, [EEx ia] IIB

Spot temperature input circuit:

| | | |
|-----------------------------------|---|------------------------------------|
| Max. values | : | U = 23.1 V, I = 221 mA, P = 0.19 W |
| Max. permissible ext. inductance | : | 3.5 mH |
| Max. permissible ext. capacitance | : | 980 nF |

HART input 1 circuit (for 762 VITO Interface):

| | | |
|-----------------------------------|---|-----------------------------------|
| Max. values | : | U = 23.1 V, I = 90 mA, P = 0.52 W |
| Max. permissible ext. inductance | : | 15 mH |
| Max. permissible ext. capacitance | : | 1.02 μ F |

HART input 2 circuit (for HART[®] pressure transmitters and/or external water probe):

| | | |
|-----------------------------------|---|------------------------------------|
| Max. values | : | U = 23.1 V, I = 148 mA, P = 0.86 W |
| Max. permissible ext. inductance | : | 7 mH |
| Max. permissible ext. capacitance | : | 1.02 μ F |

Appendix D Related documents

Instruction manual 854 XTG level gauge
Instruction manual 854 density option
Instruction manual SPU II hard alarm output contacts

Installation guide 762 VITO Interface & 764, 765 or 766 VITO temperature and/or water sensor
Installation guide 977 Tank Side Indicator

Instruction manual XPU-2 option RS-232C/RS-485
Instruction manual Temperature, Water bottom and Analog output options
Instruction manual HIMS / HTG and vapour pressure (P3) measurement
Instruction manual 847 PET

Installation info 003 "Installation of Pressure Transmitters for HTG and HIMS"

Honeywell Enraf

Delftechpark 39
2628 XJ Delft

Tel. : +31 15 2701 100
E-mail : enraf-nl@honeywell.com
Website: <http://www.honeywellenraf.com>

PO Box 812
2600 AV Delft
The Netherlands

We at Honeywell Enraf are committed to excellence.

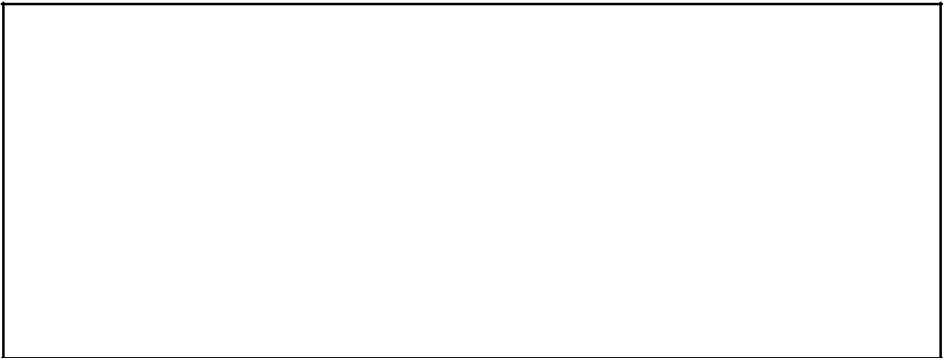

Information in this publication is subject to change without notice

Enraf is a registered trade mark. Enraf B.V. Netherlands