

# *SANITARY SERIES*

*Turbine Flowmeters for 3A Sanitary Service*

## *USER'S MANUAL*



HP-257  
March 2011

**H** **HOFFER FLOW CONTROLS, INC.**  
**PERFECTING MEASUREMENT™**

107 Kitty Hawk Lane • P.O. Box 2145 • Elizabeth City, NC 27906-2145  
1-800-4584 • 252-331-1997 • FAX: 252-331-2886  
[www.hofferflow.com](http://www.hofferflow.com) • E-mail: [info@hofferflow.com](mailto:info@hofferflow.com)



---

# NOTICE

---

Hoffer Flow Controls, Inc. makes no warranty of any kind with regard to this material, including, but not limited to, the implied warranties of merchantability and fitness for a particular purpose.

This manual has been provided as an aid in installing, connecting, calibrating, operating, and servicing this unit. Every precaution for accuracy has been taken in the preparation of this manual; however, Hoffer Flow Controls, Inc. neither assumes responsibility for any omissions or errors that may appear nor assumes liability for any damages that result from the use of the products in accordance with information contained in the manual.

HOFFER FLOW CONTROLS' policy is to provide a user manual for each item supplied. Therefore, all applicable user manuals should be examined before attempting to install or otherwise connect a number of related subsystems. During installation, care must be taken to select the correct interconnecting wiring drawing. The choice of an incorrect connection drawing may result in damage to the system and/or one of the components.

Please review the complete model number of each item to be connected and locate the appropriate manual(s) and/or drawing(s). Identify all model numbers exactly before making any connections. A number of options and accessories may be added to the main instrument, which are not shown on the basic user wiring. Consult the appropriate option or accessory user manual before connecting it to the system. In many cases, a system wiring drawing is available and may be requested from Hoffer Flow Controls.

This document contains proprietary information, which is protected by copyright. All rights are reserved. No part of this document may be photocopied, reproduced, or translated to another language without the prior written consent of Hoffer Flow Controls, Inc.

HOFFER FLOW CONTROLS' policy is to make running changes, not model changes, whenever an improvement is possible. This affords our customers the latest in technology and engineering. The information contained in this document is subject to change without notice.

THIS WARRANTY IS EXPRESSLY IN LIEU OF ALL OTHER WARRANTIES, EXPRESSED OR IMPLIED, INCLUDING ANY IMPLIED WARRANTY OF MERCHANTABILITY OR FITNESS FOR A PARTICULAR PURPOSE. HFC SHALL NOT BE LIABLE FOR ANY LOSS OR DAMAGE RESULTING, DIRECTLY OR INDIRECTLY, FROM THE USE OR LOSS OF USE OF THE GOODS. WITHOUT LIMITING THE GENERALITY OF THE FOREGOING, THIS EXCLUSION FROM LIABILITY EMBRACES THE PURCHASER'S EXPENSES FOR DOWNTIME OR FOR MAKING UP DOWNTIME, DAMAGES FOR WHICH THE PURCHASER MAY BE LIABLE TO OTHER PERSONS, DAMAGES TO PROPERTY, AND INJURY TO OR DEATH OF ANY PERSONS. HFC NEITHER ASSUMES NOR AUTHORIZES ANY PERSON TO ASSUME FOR IT ANY OTHER LIABILITY IN CONNECTION WITH THE SALE OR USE OF HFC'S GOODS, AND THERE ARE NO ORAL AGREEMENTS OR WARRANTIES COLLATERAL TO OR AFFECTING THE AGREEMENT. *PURCHASER'S SOLE AND EXCLUSIVE REMEDY IS THE REPAIR AND/OR REPLACEMENT OF NONCONFORMING GOODS AS PROVIDED IN THE PRECEDING PARAGRAPHS. HFC SHALL NOT BE LIABLE FOR ANY OTHER DAMAGES WHATSOEVER INCLUDING INDIRECT, INCIDENTAL, OR CONSEQUENTIAL DAMAGES.*

---

## Limited Warranty POLICY FOR Hoffer Flow Controls

---

HOFFER FLOW CONTROLS, INC. ("HFC") warrants HFC's Precision Series and API Series of turbine flowmeters to be free from defects in material and workmanship under normal use and service, only if such goods have been properly selected for the service intended, properly installed and properly operated and maintained as described in the turbine flowmeter manual. Reference "turbine flowmeter manual" for specific details. This warranty shall extend for a period of five (5) years from the date of shipment to the original purchaser and covers the Precision Series and API Series of flowmeters supplied with their standard hybrid ceramic ball bearings only. All other HFC products carry a one (1) year warranty. This warranty is extended only to the original purchaser ("Purchaser"). *Purchaser's sole and exclusive remedy is the repair and/or replacement of nonconforming goods as provided in the following paragraphs.*

In the event Purchaser believes the Hoffer product is defective, the product must be returned to HFC, transportation prepaid by Purchaser, within the appropriate warranty period relative to the product. If HFC's inspection determines that the workmanship or materials are defective and the required maintenance has been performed and, has been properly installed and operated, the product will be either repaired or replaced, at HFC's sole determination, free of additional charge, and the goods will be returned, transportation paid by HFC, using a transportation method selected by HFC.

Prior to returning the product to HFC, Purchaser must obtain a Returned Material Authorization (RMA) Number from HFC's Customer Service Department within 30 days after discovery of a purported breach of warranty, but not later than the warranty period; otherwise, such claims shall be deemed waived. See the Return Requests/inquiries Section of this manual.

If HFC's inspection reveals the Hoffer product to be free of defects in material and workmanship or such inspection reveals the goods were improperly used, improperly installed, and/or improperly selected for service intended, HFC will notify the purchaser in writing and will deliver the goods back to Purchaser upon receipt of Purchaser's written instructions and agreement to pay the cost of transportation. If Purchaser does not respond within thirty (30) days after notice from HFC, the goods will be disposed of in HFC's discretion.

HFC does not warrant the product to meet the requirements of any safety code of any state, municipality, or other jurisdiction, and Purchaser assumes all risk and liability whatsoever resulting from the use thereof, whether used singly or in combination with other machines or apparatus.

This warranty shall not apply to any HFC product or parts thereof, which have been repaired outside HFC's factory or altered in any way, or have been subject to misuse, negligence, or accident, or have not been operated in accordance with HFC's printed instructions or have been operated under conditions more severe than, or otherwise exceeding, those set forth in the specifications.

---

FOR **NON-WARRANTY** REPAIRS OR **CALIBRATIONS**, consult HOFFER FLOW CONTROLS for current repair/calibration charges. Have the following information available BEFORE contacting HOFFER FLOW CONTROLS:

1. P.O. number to cover the COST of the repair/calibration,
  2. Model and serial number of the product, and
  3. Repair instructions and/or specific problems relative to the product.
-

# CONTENTS

1.	Introduction.....	1
1.1	Model Number Designation.....	2
1.2	Specification .....	5
2.	Operation .....	7
2.1	Principle.....	7
2.2	Precautions.....	7
3.	Installation .....	9
3.1	General Piping .....	9
3.2	Strainers/Filters.....	11
3.3	Flow Straighteners and Installation Kits.....	11
4.	Maintenance.....	13
4.1	General.....	13
4.2	Cleaning Procedures .....	13
4.2.1	Chemical Cleaning.....	13
4.2.2	Steam Cleaning .....	14
4.3	Pickup Coil Testing .....	15
4.4	Disassembly.....	16
4.5	Assembly .....	16
4.6	Trouble Shooting .....	17
4.7	Spare Parts .....	18

Appendix A: Drawing  
Typical Assembly 3-A Sanitary Flowmeter  
With Installation Kit



## **1. Introduction**

We are proud that you have selected a Hoffer Turbine Flowmeter, the finest precision turbine flow transducer on the market.

The Hoffer Sanitary Series of turbine flowmeters are designed to meet the 3-A Sanitary Standard No. 28-03 for measurement of process liquids and can be used where high sanitary standards are required.

The information in this manual is provided to assist in the proper installation, use, and maintenance of your instrument.

Please take a few minutes to read through this manual before installing and operating your meter. If you have any problems with the meter, refer to the maintenance and troubleshooting sections of this manual.

If you need further assistance, contact your local Hoffer Representative or contact the Hoffer Flow Controls customer service department by telephone, fax, or email for advice.

We welcome you to our growing family of satisfied customers. If you are not completely satisfied with either our product or service, we encourage you to let us know. We want to improve!

### 1.1 Model Number Designation

The Model number of the meter describes various fittings and options.

**HO 3A SANITARY LIQUID TURBINE SERIES**  
**Meets New 3A Standard 28-03**

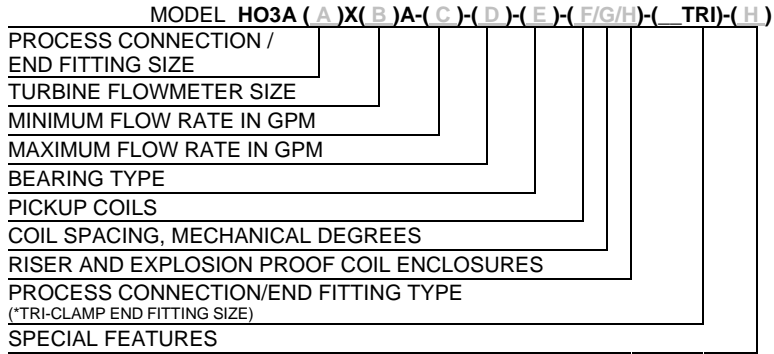

**PROCESS CONNECTION/END FITTING & TURBINE FLOWMETER SIZE**

MODEL HO3A(A)X(B)A-( )-( )-( // )-( )-( )

	(A)	(B)		(C)	(D)
*HO3A	11/2	X	1/4A		
HO3A	3/4	X	1/4A		
*HO3A	11/2	X	3/8A		
HO3A	3/4	X	3/8A		
*HO3A	11/2	X	1/2A		
HO3A	3/4	X	1/2A		
*HO3A	11/2	X	5/8A		
HO3A	3/4	X	5/8A		
*HO3A	11/2	X	3/4A		
*HO3A	11/2	X	1A		
HO3A	11/2	X	11/4A		
HO3A	11/2	X	11/2A		
HO3A	2	X	2A		
*HO3A	3	X	21/2A		
*HO3A	4	X	3A		

\*NOTE: THE MODEL NUMBERS ABOVE, MARKED WITH AN ASTERIK (\*), MUST USE A 3A INSTALLATION ADAPTER KIT (IAK) TO MAINTAIN THE 3A STANDARD OF THE TURBINE.

**MINIMUM FLOW AND MAXIMUM FLOW RATE IN GPM**

MODEL HO3A( )X( )-(C)-(D)-( // )-( )-( )

NOTE: FOR EXTENDED RANGES REFER TO ENGINEERING GUIDE HO-EG-106

TURBINE SIZE	(C)	TO	(D)
	<u>MINIMUM FLOW</u>		<u>MAXIMUM FLOW</u>
1/4	.35 GPM		3.5 GPM
3/8	.75 GPM		7.5 GPM
1/2	1.25 GPM		9.5 GPM
5/8	1.75 GPM		16 GPM
3/4	2.5 GPM		29 GPM
1	4 GPM		60 GPM
11/4	6 GPM		93 GPM
11/2	8 GPM		130 GPM
2	15 GPM		225 GPM
21/2	25 GPM		400 GPM
3	40 GPM		650 GPM



**BEARING TYPE**

MODEL HO3A( )X( )-( )-( )-(E)-( // )-( )-( )

TURBINE SIZESOPTION ( E )

1/4" THRU 11/2"	(C9)	HARD CARBON COMPOSITE SLEEVE BEARING. M-199 GRADE; NOT <u>ACCEPTABLE</u> FOR USE IN FOOD WITH pH BELOW 6.
	(C1)	HARD CARBON COMPOSITE SLEEVE BEARING. M-100 GRADE; ACCEPTABLE FOR USE IN FOOD WITH pH BELOW 6.
2"	(C9)	HARD CARBON COMPOSITE SLEEVE BEARING. M-199 GRADE; NOT <u>ACCEPTABLE</u> FOR USE IN FOOD WITH pH BELOW 6.
	(C1)	HARD CARBON COMPOSITE SLEEVE BEARING. M-100 GRADE; ACCEPTABLE FOR USE IN FOOD WITH pH BELOW 6.
21/2"	(C9)	HARD CARBON COMPOSITE SLEEVE BEARING. M-199 GRADE; NOT <u>ACCEPTABLE</u> FOR USE IN FOOD WITH pH BELOW 6.
	(C1)	HARD CARBON COMPOSITE SLEEVE BEARING. M-100 GRADE; ACCEPTABLE FOR USE IN FOOD WITH pH BELOW 6.
3"	(C9)	HARD CARBON COMPOSITE SLEEVE BEARING. M-199 GRADE; NOT <u>ACCEPTABLE</u> FOR USE IN FOOD WITH pH BELOW 6.
	(C1)	HARD CARBON COMPOSITE SLEEVE BEARING. M-100 GRADE; ACCEPTABLE FOR USE IN FOOD WITH pH BELOW 6.

NOTE: BOTH BEARINGS ARE APPROVED BY THE FOOD AND DRUG ADMINISTRATION.

**PICKUP COILS**

MODEL HO3A( )X( )-( )-( )-( )-(F// )-( )-( )

OPTION ( F )

(1M)	ONE MAG COIL
(2M)	TWO MAG COILS
(1MC3PA)	ONE RF COIL
(1MC2PAHT)	ONE HIGH TEMP 6" PIGTAIL RF COIL
(2MC2PAHT)	TWO HIGH TEMP 6" PIGTAIL RF COILS
(2MC3PA)	TWO RF COILS
(1HTM)	HIGH TEMP MAG COIL
(2HTM)	TWO HIGH TEMP MAG COILS
(1ISM)	ONE INTRINSICALLY SAFE MAG COIL
(1ISME)	ONE ISM ATEX COIL WITH A STANDARD 1" COIL RISER LESS ENCLOSURE WITH THE PRICE OF THE RISER INCLUDED. (FOR EXPORT TO INTERNATIONAL CUSTOMERS ONLY. HOFFER CANNOT SUPPORT ATEX WITH 1" RISERS.)
(2ISM)	TWO INTRINSICALLY SAFE MAG COILS
(2ISME)	TWO ISM ATEX COILS WITH A STANDARD 1" COIL RISER LESS ENCLOSURE WITH THE PRICE OF TWO RISERS INCLUDED. (FOR EXPORT TO INTERNATIONAL CUSTOMERS ONLY. HOFFER CANNOT SUPPORT ATEX WITH 1" RISERS.)
(1RPMXXX)	ONE REDI-PULSE MAG COIL
(2RPMXXX)	TWO REDI-PULSE MAG COILS
(1RPRXXX)	ONE REDI-PULSE RF COIL
(2RPRXXX)	TWO REDI-PULSE RF COILS
(1DMXXXX)	ONE REDI-PULSE INTRINSICALLY SAFE MAG COIL
(2DMXXXX)	TWO REDI-PULSE INTRINSICALLY SAFE MAG COILS
(1DRXXXX)	ONE REDI-PULSE INTRINSICALLY SAFE RF COIL

- (2DRX~~XXX~~) TWO REDI-PULSE INTRINSICALLY SAFE RF COILS  
 (-ATEX)\* WHEN ANY COIL IS GOING TO HAVE AN ATEX ENCLOSURE MOUNTED ON THE FLOWMETER ADD -ATEX AFTER THE COIL PART NUMBER.  
 (THE COIL NEEDS TO BE MODIFIED TO FIT INTO A 3/4" RISER WELDED TO THE BODY REQUIRED BY ATEX.)
- (-P\*) PIGTAIL OR FLYING LEADS, ADD -P AND THE \*LENGTH OF LEADS AFTER ANY COIL EXCEPT THE HIGH TEMPERATURE COILS.

**COIL SPACING, MECHANICAL DEGREES**

MODEL HO3A( )X( )-( )-( )-( )-( /G / )-( )-( )

NOTE ( G ) : 90 DEG. ELECTRICAL COIL SPACING FOR TWO COILS REQUIRE THE FOLLOWING MECHANICAL SPACING. IF A SECOND COIL IS NOT REQUIRED, SKIP OPTION (G) AND MOVE ON TO OPTION (H).

TURBINE SIZE	FORWARD MECH. DEGREES	REVERSE MECH. DEGREES	COIL SPARE DEGREES
1/4	ZERO	135	250
3/8	ZERO	135	250
1/2	ZERO	135	250
5/8	ZERO	135	180
3/4	ZERO	135	250
1	ZERO	135	250
1 1/4	ZERO	135	250
1 1/2	ZERO	135	250
2	ZERO	101.25	250
2 1/2	ZERO	97.50	180
3	ZERO	97.50	180
4	ZERO	97.50	180

**RISER AND EXPLOSION PROOF COIL ENCLOSURES**

MODEL HO3A( )X( )-( )-( )-( )-( /H / )-( )-( )

**OPTION ( H )**

- (X) 1" MNPT RISER, WELDED TO BODY, REQUIRED FOR ALL TYPE OF ENCLOSURES.
- (X3/O) 1" RISER WITH ENCLOSURE WITHOUT ANY SIGNAL CONDITIONER.
- (X3H/O) 1" RISER WITH ENCLOSURE AND DOME COVER FOR STYLE 1 SIGNAL CONDITIONER.
- (X3B/O) SAME AS (X3/O) WITH BASEEFA, FM AND CENELEC-EEExd APPROVALS.
- (3B/O-ATEX) 3/4" MALE NPT COIL RISER WITH ATEX-APPROVED EEExd II C ENCLOSURE.
- (X4H/O) 1" RISER WITH DOME COVER FOR ACC22 AND ACC96.
- (3B/O) 1" RISER WITH DOME COVER FOR STYLE 1 SIGNAL CONDITIONERS TO MEET GROUP B.
- (4/O) 1" RISER WITH FLAT COVER FOR STYLE 2 SIGNAL CONDITIONERS TO MEET GROUPS C & D.
- (4B/O) 1" RISER WITH DOME COVER FOR STYLE 2 SIGNAL CONDITIONERS TO MEET GROUP B.
- (X8S) ADD 8S AFTER X RISER FOR A 8" LONG S/S RISER FOR HOT AND COLD MEDIA APPLICATIONS.

NOTE: TO BE USED WHEN APPLICATION TEMPERATURES ARE BELOW -40° F AND ABOVE +140° F.

- (XD-AD) 3/4" MALE NPT COIL RISER WITH ENCLOSURE
- IEC EExd II C, ZONE 1 & 2
  - ATEX EExd II C, ZONE 1 & 2
  - FM EExd II C, CLASS I, ZONE 1
  - CSA EX-PROOF, DIV. 1 & 2; CLASS I, GROUPS A, B, C, & D; CLASS II, GROUPS E, F, & G, &
  - IP66 CLASS III
  - NEMA 4X

#### END FITTING TYPES

MODEL **HO3A**( )X( )-( )-( )-( )-( // )-( **TRI**)-( )  
 ( **TRI**) TRI-CLOVER SANITARY END FITTING

#### SPECIAL FEATURES

MODEL **HO3A**( )X( )-( )-( )-( )-( // )-( )-( **I**)

##### OPTION ( I )

- (CE) CE MARK REQUIRED FOR EUROPE.
- (PED-CE) PED REQUIRES THAT BOTH THE OPERATING PRESSURE AND TEMPERATURE MUST BE KNOWN AND ENTERED ON THE ORDER. THIS INFORMATION WILL BE MARKED ON THE HOUSING TO MEET PED REQUIREMENTS.
- (SEP-CE) SOUND ENGINEERING PRACTICE.
- (SP) ANY SPECIAL FEATURES THAT ARE NOT COVERED IN THE MODEL NUMBER, USE A WRITTEN DESCRIPTION OF THE -SP.

## 1.2 Specifications

Linearity:	± 0.5% of reading over linear flow range
Repeatability:	± 0.1% of reading
Flow Range:	0.35 to 650 gpm
Temperature Range:	-450 °F to +450 °F w/ Standard MAG coil -450 °F to +850 °F w/ Hi Temp MAG coil
Output:	10 mVrms or greater into 10K ohm load at minimum flow rate.

This page intentionally left blank.

## 2. Operation

### 2.1 Principle

All the components of the Hoffer Sanitary Series flowmeters are machined and assembled to be compliant with the 3A Sanitary Standard No. 28-02. The flowing media engages the vaned rotor causing it to rotate at an angular velocity proportional to the flow rate. The pickup coil senses the spinning motion of the rotor through the housing and converts it into a pulsing electrical signal. Summation of the pulsing electrical signal relates directly to the total flow, while the frequency is linearly related to the flow rate.

### 2.2 Precautions

- ◆ Do not drop the meter. Dropping the meter may result in damage to the meter housing and/or internals.
- ◆ Do not operate the meter at flowrates greater than the maximum flowrate marked on the meter. Operating at flowrates greater than the maximum flowrate may over-spin the meter. Over-spinning may result in damage to the meter.

**CAUTION:** *Avoid over-spinning the meter. Over-spinning the meter may result in damage to the meter internals and lead to meter failure.*

This page intentionally left blank.

### 3. Installation

**CAUTION:** *Turbine meter has to be installed with pickup coil pointing down (see Appendix A) to ensure proper cleanability according to the 3A standards..*

Upon receipt of the turbine flowmeter carefully inspected it, checking for any indications of damage which may have occurred during shipment. Inspect all packing material carefully for parts or auxiliary components which may have been packed with the shipment. Refer to the packing list/invoice for a detailed list of items included in the shipment.

#### 3.1 General Piping

The meter housing is marked by a flow direction arrow to indicate the calibrated direction of flow through the meter. The meter must be installed in the piping in the correct orientation to ensure the most accurate and reliable operation. Care should be taken in the proper selection of the mating fittings. Size, type of material, and pressure rating should be the same as the flowmeter supplied. The correct gaskets and clamps should be utilized.

When it is expected that flow will be intermittent, the meter should not be mounted at a low point in the piping system. Solids which settle or congeal in the meter may affect meter performance.

In order to achieve optimum electrical signal output from the flowmeter, due consideration must be given to its isolation from ambient electrical interference such as nearby motors, transformers, and solenoids.

The fluid moving through the flowmeter engages the vaned rotor and swirl present in the fluid ahead of the meter can change the effective angle of engagement and, therefore, cause a deviation from the supplied calibration (performed under controlled flow conditions). Turbine meters are constructed with flow straighteners to minimize the affects of fluid swirl and non-uniform velocity profiles and are adequate for most installations. However, it is good practice to maintain a minimum straight run of approximately 10 pipe diameters ahead of the inlet and 5 pipe diameters following the outlet. Proper installation of the flowmeter minimizes the negative effects of fluid swirl.

A typical flowmeter installation is shown below:

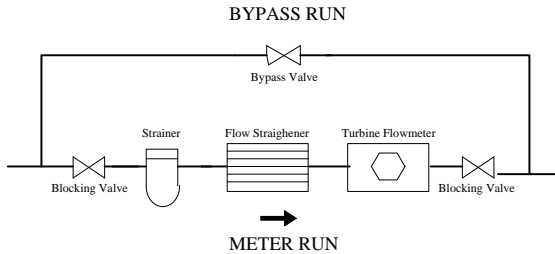

**Typical Flowmeter Installation**

Blocking and Bypass valves should be installed if it is necessary to do preventive maintenance on the flowmeter without shutting down the flow system. The Bypass valve can be opened before the Blocking valves are closed allowing the flow to continue while removing the turbine flowmeter for service.

---

**IMPORTANT:** *All flow lines should be purged prior to installing the meter. To prevent possible damage to the meter, install the meter **ONLY** in flow lines that are clean and free of debris.*

---

Upon initial start-up of the system a spool piece should be installed in place of the flowmeter so that purging of the system can be performed to remove all particle debris which could cause damage to the meter internals. In applications where meter flushing is required after meter service, care should be taken as to not over-spin the meter, as severe meter damage may occur.

**CAUTION:** *Avoid over-spinning the meter. Over-spinning the meter may result in damage to the meter internals and lead to meter failure.*

To maintain an accurate flow measurement it is necessary to maintain a downstream pressure sufficient to prevent flashing/cavitation.

Flashing of the liquid will result in an indication of flow significantly higher than the actual flow. In order to eliminate this condition



adequate downstream pressure must be maintained. The minimum required downstream pressure may be calculated using the following equation:

$$\text{Minimum Pressure} = (2 \times \text{Pressure Drop}) + (1.25 \times \text{Vapor Pressure})$$

Downstream pressure may be maintained by a downstream valve that provides the necessary downstream pressure to prevent flashing/cavitation in the metering run.

### 3.2 Strainers/Filters

Turbine flowmeters are designed for use in a clean fluid service. However, the service fluid may carry some particulate material which would need to be removed before reaching the flowmeter. Under these conditions a strainer/filter may be required to reduce the potential hazard of fouling or damage that may be caused by foreign matter.

METER SIZE	MESH SIZE	PARTICLE SIZE (Maximum)
1/4" to 1/2"	100	.0055
5/8" to 1 1/4"	70	.008
1 1/2" to 3"	40	.015

If a strainer/filter is required in the system, it should be located upstream of the flowmeter taking care that the proper minimum distance is kept between the strainer and flowmeter.

### 3.3 Flow Straighteners and Installation Kits

Proper application of the Hoffer Sanitary Series Flowmeter requires a minimum inlet straight pipe run of 10 pipe diameters and a minimum outlet straight pipe run of 5 pipe diameters.

Installation kits for the Hoffer Sanitary Series Flowmeter consist of two lengths of appropriate tubing cut to a length appropriate for the upstream and downstream straight pipe run with appropriate end fittings. Flow straightening sections may be provided within the installation kit.

This page intentionally left blank.

## 4. Maintenance

### 4.1 General

With the early design, field repairs are not recommended. Should any of these meters require repairs, it is recommended that the meter be returned to the factory. The later design allows for field repairs. When making field repairs carefully follow the disassembly and assembly instructions in the following sections. Consult the Factory to determine the meter design.

### 4.2 Cleaning Procedures

The Hoffer Sanitary Series flowmeters have been designed to allow for cleaning by commercially accepted practices. These include removing the flowmeter from the line for cleaning in an approved fluid, flushing the line with an approved cleaning solution, and steam cleaning. With all cleaning methods, care must be taken to not over-spin the meter, as severe meter damage may occur.

**CAUTION:** *Avoid over-spinning the meter. Over-spinning the meter may result in damage to the meter internals and lead to meter failure.*

#### 4.2.1 Chemical Cleaning

The flowmeters may be chemically cleaned using an approved cleaning solution by either removing the meter from the service line and using a bath or by flushing the meter in place.

The hard carbon composite bearing designs used have been tested and found to be compatible with the following CPI fluids manufactured by Klenzade; Mandate, AC-300, AC-101, Principle, and XY-12.

Following the cleaning operation, the cleaning solution should be flushed from the meter and/or service line with potable water to remove the chemically active cleaning solution.

Care should be taken to ensure that flowrates occurring during chemical cleaning do not exceed the flow capacity of the flowmeter.

### 4.2.2 Steam Cleaning

Steam cleaning is only recommended for meters with hard carbon composite bearings.

The steam flow velocity during the cleaning should not exceed 1/3 of the maximum liquid flow capacity of the flowmeter.

#### Steam Cleaning Rates at Various Steam Pressures

Meter Size	50 psig PPH <sup>1</sup>	75 psig PPH <sup>1</sup>	100 psig PPH <sup>1</sup>	125 psig PPH <sup>1</sup>	Velocity FPS <sup>2</sup>	Rate GPM <sup>3</sup>
¼	1.25	1.70	2.25	2.50	1.72	1.05
3/8	2.70	3.67	4.75	5.39	3.68	2.25
½	3.50	4.73	6.14	7.00	4.74	2.90
5/8	5.78	7.82	10.20	11.50	5.02	4.80
¾	10.50	14.20	18.40	20.90	6.32	8.70
1	21.70	29.40	38.10	43.10	7.35	18.00
1 ¼	33.70	45.70	59.30	67.10	7.32	28.00
1 ½	47.00	63.60	82.50	93.50	7.08	39.00
2	81.30	110.10	142.80	162.00	6.89	67.50
2 ½	144.60	196.00	254.00	288.00	7.84	120.00
3	235.00	318.00	412.60	467.00	8.85	195.00

#### NOTES

1. PPH = Pounds Per Hour
2. The velocity is expressed for a line size equal to the inlet bore of the flowmeter.
3. The apparent GPM is provided since many applications have a flow rate indicator which can be used to set a safe flow rate during the steam cleaning cycle.

### 4.3 Pickup Coil Testing

Testing the MAG and MCP (RF) coils consists of measuring the resistance with an ohmmeter. Resistance measurements are to be made only when there is no flow through the meter.

1. Measure the resistance between pin A and pin B. The resistance should be approximately as listed in the following table of some common coils.
2. The resistance from any pin to the case should be greater than 1 Mohm.

COIL*	DC RESISTANCE
	(Ohms)
MC2PAHT	15.0 ±10%
MCP3A	11.5 ±10%
PC13-74G	1800 ±10%
PC13-74S	1850 ±15%
PC24-45G	1350 ±10%
PC24-45S	1850 ±15%
PC28-13G	120 ±20%
PC28-14G	180 ±20%

If either resistance measurement fails, replace the pickup coil. Firmly seat the new coil in the flowmeter and tighten the locking nut.

### Pickup Connections

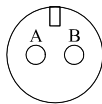

MAG

A - Signal (+)  
B - Common (-)



MCP (RF)

A - Signal (+)  
B - Common (-)  
C - N/C

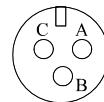

RediPulse

A - 8 - 30 Vdc  
B - Common (-)  
C - Pulse Output

\* For specific coils not listed contact the HFC Customer Service Department for the approximate resistance readings.

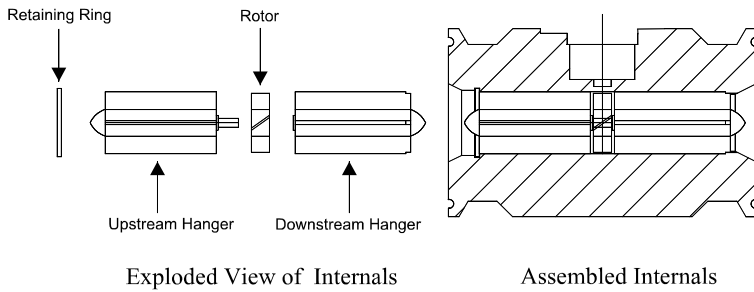

#### 4.4 Disassembly

1. Remove the retaining ring from the inlet end of the meter.
2. Using a blunt tool, carefully push the internals out of the meter through the inlet end.
3. Remove the coil **ONLY** if it must be replaced.

#### 4.5 Assembly

1. The down stream hanger is placed into the housing with the bearing end toward the inlet end. Ensure that the hanger is firmly against the shoulder at the outlet end. Use a blunt tool so as not to damage the hanger.
2. Place the rotor on the upstream hanger. Ensure that the rotor "IN" faces the upstream hanger.
3. Place the upstream hanger in the housing. Align the hanger with the downstream hanger.
4. Replace the retainer ring using an appropriate tool.
5. Check for rotor endplay. The rotor should have free lateral movement and should make a rattling noise when gently shaken from end-to-end.

## 4.6 Trouble Shooting

Refer to the following troubleshooting guide for assistance with possible meter malfunctions:

TROUBLE	CAUSE	REMEDY
Fluid will not flow Through the meter	<ul style="list-style-type: none"> <li>▪ Meter clogged.</li> <li>▪ Line to meter blocked.</li> </ul>	Clear meter. Clear line to meter.
Reduced flow through the meter	<ul style="list-style-type: none"> <li>▪ Meter partially clogged.</li> <li>▪ Line to meter partially blocked.</li> </ul>	Clear meter. Clear line to meter.
Meter readings inaccurate	<ul style="list-style-type: none"> <li>▪ Fluid flowrate is not within meter flow range.</li> <li>▪ Meter drag due to improper installation</li> </ul>	See "Specifications" for min and max flowrates. Replace internals.
Meter not giving pulse Signal	<ul style="list-style-type: none"> <li>▪ Faulty pickup coil.</li> <li>▪ Meter internals not turning due to improper installation.</li> </ul>	Replace pickup coil. Replace internals.

#### 4.7 Spare Parts

The following table contains the recommended spare parts for the Hoffer Sanitary Series flowmeters:

<b>Item No.</b>	<b>Qty</b>	<b>Part No.</b>	<b>Part Description</b>
1	1	300-#### <sup>1</sup>	Pickup Coil
1	1	300-#### <sup>2</sup>	Retaining Ring
1	1	300-#### <sup>2</sup>	Upstream Hanger
1	1	300-#### <sup>2</sup>	Rotor Assembly
1	1	300-#### <sup>2</sup>	Downstream Hanger

---

<sup>1</sup> Specific pick-up coil is application dependent. Consult with the factory for the correct part number. Have complete meter model number or pick-up coil model number available.

<sup>2</sup> Meter internals are order by the size of the meter. Consult with the factory for the correct part number. Have complete meter model number available.



# DRAWING

Typical Assembly

3-A Sanitary Flowmeter With Installation Kit

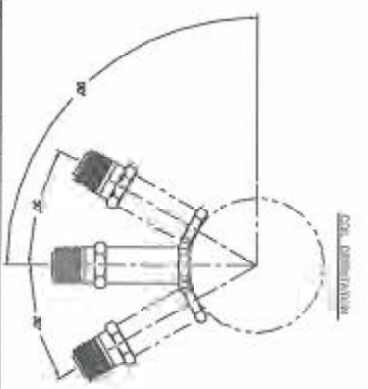
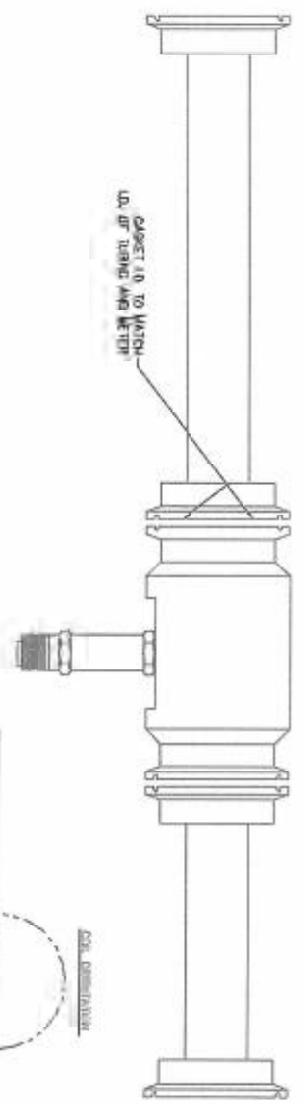

REV.	DATE	DESCRIPTION	BY	CHKD.
1	3/3/21	HOX-40235		
2				
3				
4				
5				
6				
7				
8				
9				
10				
11				
12				
13				
14				
15				
16				
17				
18				
19				
20				
21				
22				
23				
24				
25				
26				
27				
28				
29				
30				
31				
32				
33				
34				
35				
36				
37				
38				
39				
40				
41				
42				
43				
44				
45				
46				
47				
48				
49				
50				
51				
52				
53				
54				
55				
56				
57				
58				
59				
60				
61				
62				
63				
64				
65				
66				
67				
68				
69				
70				
71				
72				
73				
74				
75				
76				
77				
78				
79				
80				
81				
82				
83				
84				
85				
86				
87				
88				
89				
90				
91				
92				
93				
94				
95				
96				
97				
98				
99				
100				

**H** HOFFER FLOW CONTROLS, INC.  
 ELIZABETH CITY, NC 27809  
 TYPICAL ASSEMBLY  
 3-A SANITARY FLOWMETER  
 WITH INSTALLATION KIT

HOX-40235  
 3/3/21  
 1 OF 1

A B C D

4 3 2 1

A B C D

4 3 2 1