

Ultrasonic flowmeters

SITRANS FUE1010 IP40 (NEMA 1)
7ME3502 Energy Portable Flowmeter

Operating Instructions - January 2013



SITRANS F

Answers for industry.

SIEMENS

SIEMENS

SITRANS F

Ultrasonic Flowmeters FUE1010 IP40 (NEMA 1) Energy Portable



Operating Instructions

<u>Introduction</u>	1
<u>Safety notes</u>	2
<u>Description</u>	3
<u>Installing/Mounting</u>	4
<u>Connecting</u>	5
<u>Commissioning</u>	6
<u>Functions</u>	7
<u>Alarm, error, and system messages</u>	8
<u>Maintenance and service</u>	9
<u>Troubleshooting</u>	10
<u>Technical data</u>	11
<u>Appendix</u>	A
<u>Appendix</u>	B

Legal information

Warning notice system

This manual contains notices you have to observe in order to ensure your personal safety, as well as to prevent damage to property. The notices referring to your personal safety are highlighted in the manual by a safety alert symbol, notices referring only to property damage have no safety alert symbol. These notices shown below are graded according to the degree of danger.

 DANGER
indicates that death or severe personal injury will result if proper precautions are not taken.
 WARNING
indicates that death or severe personal injury may result if proper precautions are not taken.
 CAUTION
indicates that minor personal injury can result if proper precautions are not taken.
NOTICE
indicates that property damage can result if proper precautions are not taken.

If more than one degree of danger is present, the warning notice representing the highest degree of danger will be used. A notice warning of injury to persons with a safety alert symbol may also include a warning relating to property damage.

Qualified Personnel

The product/system described in this documentation may be operated only by **personnel qualified** for the specific task in accordance with the relevant documentation, in particular its warning notices and safety instructions. Qualified personnel are those who, based on their training and experience, are capable of identifying risks and avoiding potential hazards when working with these products/systems.

Proper use of Siemens products

Note the following:

 WARNING
Siemens products may only be used for the applications described in the catalog and in the relevant technical documentation. If products and components from other manufacturers are used, these must be recommended or approved by Siemens. Proper transport, storage, installation, assembly, commissioning, operation and maintenance are required to ensure that the products operate safely and without any problems. The permissible ambient conditions must be complied with. The information in the relevant documentation must be observed.

Trademarks

All names identified by ® are registered trademarks of Siemens AG. The remaining trademarks in this publication may be trademarks whose use by third parties for their own purposes could violate the rights of the owner.

Disclaimer of Liability

We have reviewed the contents of this publication to ensure consistency with the hardware and software described. Since variance cannot be precluded entirely, we cannot guarantee full consistency. However, the information in this publication is reviewed regularly and any necessary corrections are included in subsequent editions.

Table of contents

1	Introduction.....	9
1.1	Preface.....	9
1.2	Items supplied.....	9
1.3	History.....	10
1.4	Further Information.....	10
2	Safety notes.....	11
2.1	Warning Symbols.....	12
2.2	Laws and directives.....	13
2.3	Lithium batteries.....	14
2.4	Certificates.....	14
3	Description.....	15
3.1	FUE1010 features.....	15
3.2	Applications.....	16
3.3	Theory of Operation.....	17
4	Installing/Mounting.....	23
4.1	Installation safety precautions.....	23
4.2	Determining a location.....	23
4.3	Use according to specifications.....	24
4.4	Application Guidelines.....	24
4.5	AC Battery Charger.....	25
5	Connecting.....	27
5.1	Transmitter Wiring.....	27
5.1.1	Forming the Internal Battery.....	27
5.1.2	Connecting AC Power Adapter/Charger.....	29
5.2	Sensor Wiring.....	30
5.2.1	Preliminary Installation Procedures.....	30
5.2.2	Sensor Identification and Selection.....	33
5.2.3	Navigating the Menu.....	36
5.2.4	Setting the Parameters.....	38
5.2.5	Reflect Mount.....	44
5.2.6	Direct Mount.....	48
5.2.7	1012T Mounting Tracks.....	54
5.3	Zero Flow Adjust Menu.....	63

6	Commissioning	69
6.1	General requirements	69
6.2	Commissioning.....	69
6.3	Empty Pipe Set	70
6.4	Installation Menus	73
7	Functions	79
7.1	Selecting Flow Units.....	79
7.2	Span Data	84
7.3	Logger Control	86
7.4	Operation Adjust Menu Settings	89
7.5	Setting Relays	92
7.6	Memory Control.....	94
7.7	Analog Out Setup.....	95
7.8	Analog Input Setup.....	98
7.9	Energy AnCal	102
7.10	Analog Output Trim	103
7.11	RTD Calibration.....	106
7.12	Reflexor	109
8	Alarm, error, and system messages	121
8.1	Alarm Codes	121
9	Maintenance and service	123
9.1	Maintenance.....	123
9.2	Replacing the battery	123
9.3	Battery disposal.....	126
9.4	Technical support.....	127
9.5	Return procedures	128
10	Troubleshooting	129
10.1	Troubleshooting	129
10.2	F4 Reset Procedure	132
10.3	Test Facilities Graph Screen.....	133
10.4	Site Setup Data	143
11	Technical data	149
11.1	Technical Data	149
A	Appendix.....	151
A.1	Ordering	151

A.2	I/O Connections and Wiring	151
A.3	Site Setup For SITRANS F	152
A.4	Flowrate Calibration and Calibration Tables	160
B	Appendix.....	163
B.1	Installation/Outline Drawings	163
	Glossary	165
	Index.....	171

Tables

Table 4- 1	Power Cord Codes.....	26
Table 5- 1	Keypad Function Chart	37
Table 5- 2	Pipe Configuration Option List Definitions	42
Table 7- 1	Totalizer Modes	80
Table 7- 2	Totalizer Controls (the "n" in <Fn> = channel number)*	83
Table 7- 3	Logger Control Menu Option List.....	86
Table 7- 4	Relay Option List.....	93
Table 7- 5	Memory Control Menu	94
Table 7- 6	Analog Outputs	95
Table 7- 7	Analog Out Setup Data Categories	95
Table 7- 8	Analog Out Trim Menu Structure	103
Table 7- 9	RTD Calibrate Menu Structure.....	107
Table 7- 10	Inline Metal and Plastic Pipe Cable Connections	112
Table 7- 11	Cursor Definitions	117
Table 7- 12	Diagnostic Data.....	119
Table 10- 1	Troubleshooting Tips	129
Table 10- 2	Description of Graph Screen Text Display Parameters.....	141
Table 10- 3	Hot Key Summary.....	142
Table 10- 4	Site Setup Menu Items.....	143
Table 11- 1	Performance Specifications	149
Table A- 1	Part Numbers and Connection Data.....	151
Table A- 2	Dual Channel/Dual Path Input/Output DB-25 Connector Wiring	151

Figures

Figure 3-1	Ruggedized Case-shown open.....	15
------------	---------------------------------	----

Figure 4-1	Power Adapter/Battery Charger.....	25
Figure 5-1	Power Adapter/AC-Charger for Dual Channel Flow Meter.....	29
Figure 5-2	Reflect Mount (Pipe shown from above in 12 o'clock position).....	30
Figure 5-3	Direct Mount (Pipe shown from above in 12 o'clock position).....	31
Figure 5-4	Sensor Alignment (Horizontal Plane).....	32
Figure 5-5	Pipe Surface Preparation.....	33
Figure 5-6	Universal Sensor Label.....	34
Figure 5-7	Hi Precision Sensor Label.....	35
Figure 5-8	KeyPad.....	36
Figure 5-9	Typical Installation Menu Screen.....	37
Figure 5-10	Reflect Mount with EZ-Clamp and Spacer Bar.....	44
Figure 5-11	Sensor Mounting with EZ Clamp and Spacer Bar.....	46
Figure 5-12	EZ Clamp S-Hook.....	46
Figure 5-13	Sensor.....	46
Figure 5-14	Connecting Sensors to Flow Meter.....	47
Figure 5-15	Mylar Spacing Guide.....	48
Figure 5-16	EZ Clamping Sensor to Pipe.....	49
Figure 5-17	EZ Clamp S-Hook.....	49
Figure 5-18	Sensor.....	49
Figure 5-19	Wrapping the Mylar Spacing Guide around the pipe (End View).....	51
Figure 5-20	Finding the Halfway Distance.....	52
Figure 5-21	Aligning the Sensors for Direct Mode (End View).....	52
Figure 5-22	Connecting Sensors to Flow Meter.....	53
Figure 5-23	Reflect Mount with Model 1012TP Mounting Track (Side View).....	55
Figure 5-24	Reflect Mode Chain Loop (Front View).....	56
Figure 5-25	Direct Mount 180° opposed with Mounting Tracks.....	58
Figure 5-26	Direct Mount Roller Chain.....	59
Figure 5-27	Wrapping the Mylar Spacing Guide around pipe (End View).....	60
Figure 5-28	Finding the Halfway Distance.....	60
Figure 5-29	Track Rail Alignment.....	61
Figure 5-30	REF and Number Index Pin Locations.....	62
Figure 7-1	Sensor Mounting Examples.....	111
Figure 7-2	Adjacent Sensor Mounting.....	112
Figure 7-3	In-Line Sensor Mounting.....	113
Figure 7-4	Spectra Graph Display Screen.....	116
Figure 9-1	Faceplate Removal.....	124

Figure 9-2	Battery Cover Removal.....	125
Figure 9-3	Battery Removal/Replacement	126
Figure 10-1	Test Facilities Graph Screen.....	134
Figure 10-2	Setting Digital Damping Factor	137
Figure 10-3	Setting the MinDamp Factor	138
Figure 10-4	Envelope Threshold Adjustment.....	140

Introduction

1.1 Preface

These instructions contain all the information you need for using the device.

The instructions are aimed at persons mechanically installing the device, connecting it electronically, configuring the parameters and commissioning it as well as service and maintenance engineers.

Note

It is the responsibility of the customer that the instructions and directions provided in the manual are read, understood and followed by the relevant personnel before installing the device.

1.2 Items supplied

- SITRANS F Transmitter
- SITRANS F literature CD
- For additional items refer to your packing slip.

Inspection

1. Check for mechanical damage due to possible improper handling during shipment. All claims for damage are to be made promptly to the shipper.
2. Make sure the scope of delivery, and the information on the type plate corresponds to the ordering information.

1.3 History

The contents of these instructions are regularly reviewed and corrections are included in subsequent editions. We welcome all suggestions for improvement.

The following table shows the most important changes in the documentation compared to each previous edition.

Edition	Remarks
02/2010	First Edition of Operating Instructions for the SITRANS FUE1010 IP40 NEMA 1 portable energy flowmeter.
01/2013	Second Edition of Operating Instructions for the SITRANS FUE1010 IP40 NEMA 1 portable energy flowmeter. This document replaces all previous Instructions for use. The most important changes are as follows: <ul style="list-style-type: none">• To use the Si-Ware download the program at [http://s13.me/ns/cv]• Updated "Forming the Internal Battery" procedure• Removed all references to External Battery Pack and Charger• Added Reflexor operating mode chapter• Updated Sensor label and sensor selection procedures• Added 2mA drop fault indication note• Added DIN pipe size table 2448 reference note• Added Empty Pipe Set procedure• Updated Troubleshooting Table

1.4 Further Information

Product information on the Internet

The Operating Instructions are available on the CD-ROM shipped with the device and on the Internet on the Siemens homepage, where further information on the range of SITRANS F flow meters may also be found: Product information on SITRANS F in the Internet (<http://www.siemens.com/sitransf>)

Worldwide contact person

If you need more information or have particular problems not covered sufficiently by the operating instructions, please get in touch with your contact person. You can find contact information for your local contact person on the Internet: www.siemens.com Local contact person (<http://www.automation.siemens.com/partner>)

Safety notes

2

 CAUTION
--









Correct, reliable operation of the product requires proper transport, storage, positioning and assembly as well as careful operation and maintenance. Only qualified personnel should install or operate this instrument.

Note

Alterations to the product, including opening or improper repairs of the product, are not permitted.

If this requirement is not observed, the CE mark and the manufacturer's warranty will expire.

2.1 Warning Symbols

Symbol	Explanation
	Consult operating instructions
	Hot surface
	Dangerous electrical voltage
	Corrosive materials
	Toxic materials
	Isolate the device from power using a circuit-breaker
	Protect the device from impact otherwise loss of degree of protection
	Protective insulation; device in protection class II

2.2 Laws and directives

General requirements

Installation of the equipment must comply with national regulations. For example, the National Electrical Codes.

Instrument safety standards

The device has been tested at the factory, based on the safety requirements. In order to maintain this condition over the expected life of the device the requirements described in these Operating Instructions must be observed.

NOTICE
Material compatibility
Siemens can provide assistance with the selection of sensor parts. However, the full responsibility for the selection rests with the customer and Siemens can take no responsibility for any failure due to material incompatibility.

CE marked equipment

The CE-mark symbolizes the compliance of the device with the following Directives:

- EMC-Directive 2004/108/EC
- Low voltage Directive 2006/95/EC
- ATEX Directive 94/9/EC

2.3 Lithium batteries

Lithium batteries are primary power sources with high energy content designed to represent the highest possible degree of safety.

 WARNING
Potential hazard Lithium batteries may present a potential hazard if they are abused electrically or mechanically. <ul style="list-style-type: none">• Observe the following precautions when handling and using lithium batteries:<ul style="list-style-type: none">– Do not short-circuit, recharge or connect with false polarity.– Do not expose to temperature beyond the specified temperature range or incinerate the battery.– Do not crush, puncture or open cells or disassemble battery packs.– Do not weld or solder to the battery's body.– Do not expose contents to water.

2.4 Certificates

Certificates are posted on the Internet and on the documentation CD-ROM shipped with the device.

See also

Technical data (Page 149)

Certificates on the Internet (<http://www.siemens.com/processinstrumentation/certificates>)

Description

3.1 FUE1010 features

Description

The Siemens SITRANS FUE1010 IP40 (NEMA 1) Energy Portable flow meters achieve highly accurate flow measurement using WideBeam ultrasonic transit-time technology. The sensors are mounted on the outside of the pipe, preventing contact with the medium. This means no cavities or clogging by high paraffin liquids found in many hydrocarbon applications.

The sensors offer superior performance in terms of volumetric flow accuracy, density accuracy, and turn-down ratio. The sensor construction makes installation and commissioning of even the largest sizes very straight forward and easy.

The sensors deliver true multi-parameter measurements, i.e. volume flow and temperature.

The flow meter has a degree of protection of IP40 (NEMA 1).

Note

This operating Instructions manual applies to the following FUE1010 IP40 (NEMA 1) operating systems: Version 3.02.02 and later and version 4.03.00 and later.

Portable Configurations

The FUE1010 Energy portable flow meter is available in a dual channel/dual path configuration. It uses a light weight plastic case for easy transporting and operation. The following portable model is available:

- FUE1010 Dual Channel/Dual Path Multi-Function Portable

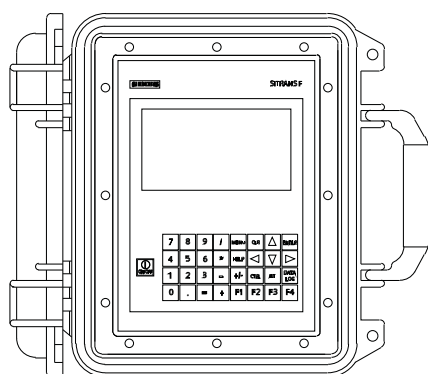

Figure 3-1 Ruggedized Case-shown open

3.2 Applications

Channel Functions

The system software allows simultaneous operation of one channel in the Transit-Time mode and the other in Reflexor mode.

Transit-Time Mode

All SITRANS F 1010 models use transit-time flow measurement technology varying only in functionality and environmental housing.

Reflexor Mode

The SITRANS F 1010 transit-time flow meter is highly resistant to the effects of liquid non-homogeneity caused by the inclusion of air or solid particulate. However, sonic beam scattering may occur when mineral-based solids or gaseous content is a high percentage of the volume. This can cause difficulty in operation due to signal attenuation. Liquid conditions that may be unsuitable for transit-time operation can be measured using the Reflexor mode. Dual channel portable systems allow operation with one transit-time channel and one Reflexor channel measuring flow on the same pipe.

3.2 Applications

Measurement of liquids

SITRANS F flow meters are designed for measurement of a variety of liquids. The transmitters are multi-parameter devices offering accurate measurement of volume flow and temperature.

Typical Applications

The typical applications of the flow meter for heat energy flow include:

- Chilled water
- Hot water
- Condenser water
- Lake source cooling
- Thermal storage
- Chemical feed flow

Typical Industries Serviced

- HVAC (Hotels, Airports, Government, District heating)
- Power Generation (Nuclear, Fossil, and Hydro)
- Chemical Processing

- Food and Pharmaceutical
- Aircraft Avionics and Ground Support
- Water and Wastewater
- Aerospace
- Automobile Manufacturing
- Hydrocarbon Industries

3.3 Theory of Operation

The liquid flow meter relies on the MultiPulse transit. Two WideBeam ultrasonic sensors per measuring path, alternating as transmitter and receiver, are used to interrogate the liquid flowing within the metering section. The resulting time of arrival for each direction of transmit (upstream and downstream) is then measured using a highly accurate and stable digital signal processing method.

Using this detection scheme, the flow meter is capable of resolving the relative transit-time difference (ΔT) to within ± 100 psec. Considering typical liquid flow transit-time differences ranging from 1×10^4 to 1×10^6 psec, the flow meter is capable of providing an exceptional turn-down ratio. The flow meter also incorporates a correlation technique which enables the system to detect very high flow velocities with the same high degree of resolution. The ultrasonic sensors are designed with sufficient beam divergence characteristics to insure that the receive sensor will always have sufficient signal to maintain operation under conditions of high beam blowing associated with high flow velocities.

With accurate signal arrival time available, the flow meter can compute the raw flow velocity from the measured upstream and downstream transit times.

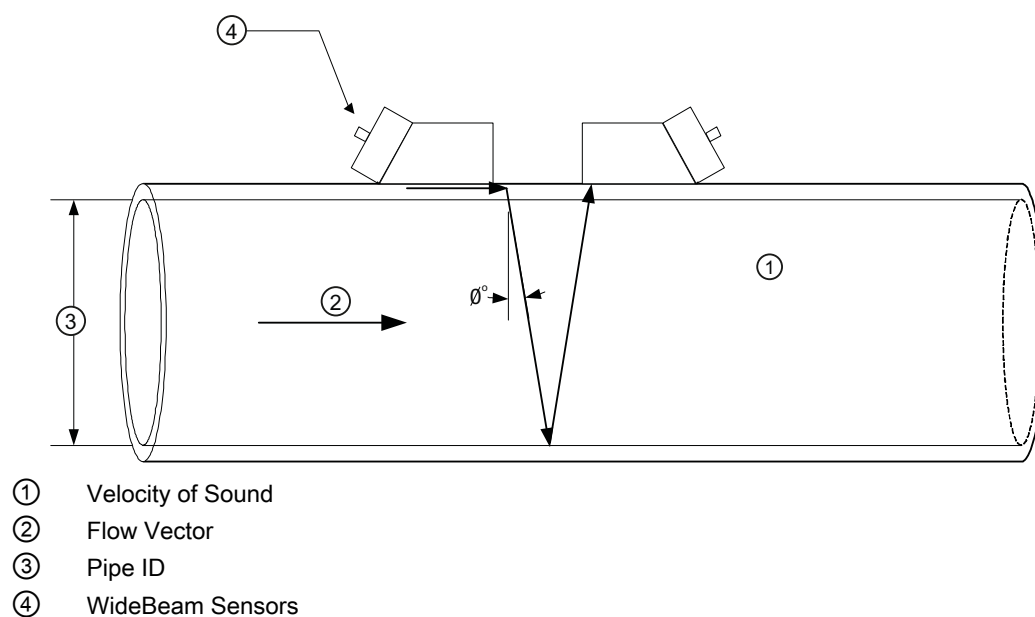

3.3 Theory of Operation

$$\varnothing^\circ = \sin^{-1}(VOS / V_{\text{phase}})$$

$$T_L = 2 * ID / (VOS * \cos \varnothing)$$

$$V_F = V_{\text{phase}} * DT / (2 * T_L)$$

Where:

VOS = Velocity of sound in liquid

V_{phase} = Phase velocity of sensor

ID = Pipe inside diameter

T_L = Transit time in liquid

DT = Measured Transit-Time difference

V_F = Flow Velocity

Flow Profile Compensation

Another important consideration is that the ultrasonic flow meter has to compensate for the flow profile to maintain calibration accuracy. Shown below is a graphic of a "fully-developed" flow profile. Note that the fluid velocity increases toward the center (axis) of the flow stream.

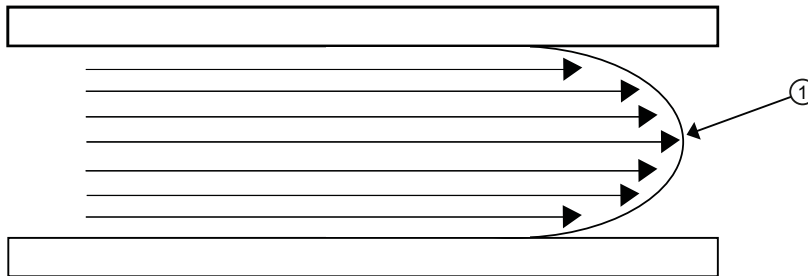

- ① Fluid velocity near the axis of the flow stream tends to be greater.

The Reynolds number is then computed as follows:

$$Rn = \frac{645 * \text{Pipe ID} * V_F}{\text{Viscosity}}$$

where viscosity = cS = cP/density

cS = kinematic viscosity

cP = absolute viscosity

The flow meter then uses this computation of Reynolds number to compensate the raw flow velocity for conditions of laminar or turbulent flow profile as defined by an internal Reynolds compensation table. The flow meter then converts the compensated flow velocity to volumetric flow rate.

$$\text{Rate} = V_F * \text{Comp}(Rn) * \text{Pipe area}$$

Flow meter Types

The flow meter automatically conditions Installation Menu choices to suit the selected meter type. The following illustrates the 2-Channel and 2-Path energy flow meter types.

2-Channel

Dual Channel provides two independent measurement channels that operate simultaneously. Depending on the specific model, Dual Channel supports: Clamp-on Transit-time, In-line Transit-time and Reflexor.

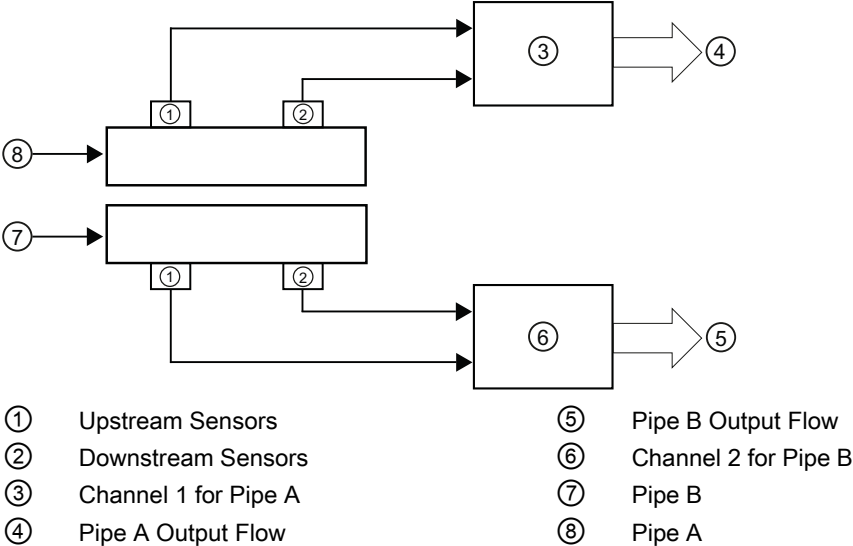

2-Path

2-Path flow meters use two measurement channels to achieve a single output via a "virtual" third channel. The resultant data is the average of the two channels. Only clamp-on or in-line transit-time operation is allowed. Benefits include highest available precision and enhanced immunity to distorted flow profile conditions.

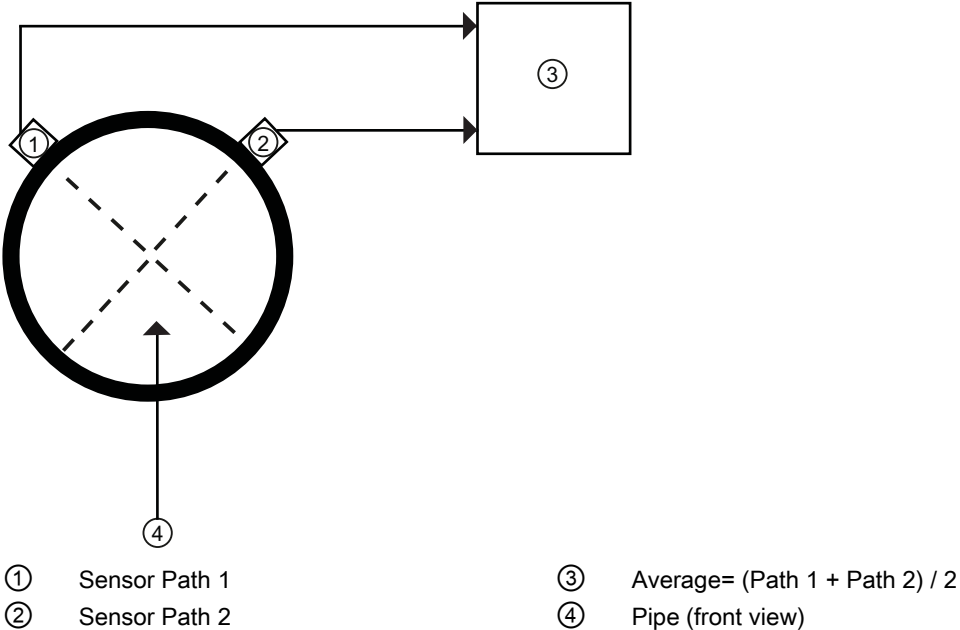

WideBeam Transmission

As shown in the figure below, an ultrasonic sensor induces an axial sonic beam within the wall of the pipe. These vibrations spread along the pipe wall and then enter the liquid in the form of a WideBeam wave front traveling at an angle to the main pipe axis. The wide beam "rains" over the receiving sensor. The wide coverage of the receiver is necessary because the angle of the sonic beam is related to the liquid's sonic propagation velocity by Snell's Law.

$$\text{Beam Angle} = \text{Arc Sine} \left(\frac{\text{Liquid Sonic Propagation Velocity}}{\text{Transducer Phase Velocity}} \right)$$

According to this formula, it can be stated that as the liquid sonic propagation velocity changes so will the angle between the sonic beam and the flow stream.

Therefore, a significant liquid sonic velocity shift could deflect a "narrow" beam transmission away from the receiving sensor entirely. The upstream vs. downstream transit-time difference will also be affected by the changing (or refracting) beam angle. This makes it necessary for TransLoc systems to continuously compute this angle, since it is subject to varying degrees of refraction. The flow meter derives the angle by knowing the fixed position of the sensors, the dimensions of the pipe and the measured transit-time. Therefore, the flow meter computes the beam angle relative to the axis of the pipe.

Flow Calibration Factor

Normally, the flow stream is in line with the axis of the pipe. On this basis, the calibration factor of a clamp-on ultrasonic flow meter is proportional to the cosine of the beam angle relative to the pipe axis. However, this reveals that if the angle of flow stream is not in line with the pipe axis, the flow calibration factor could be compromised. This most often occurs when the sensor mounting location is within close proximity of a bend or other pipe obstruction. It is recommended that, whenever possible, mount sensors on the longest available straight run of pipe and also use Reflect Mode mounting (as shown below).

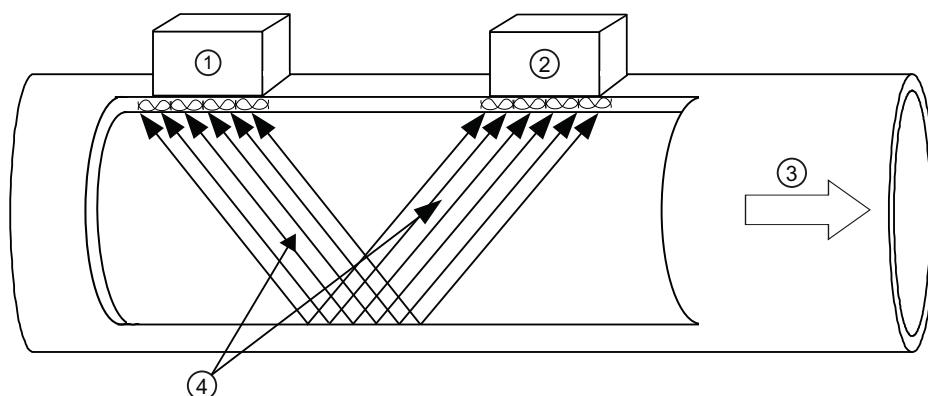

- ① Upstream Sensor
- ② Downstream Sensor
- ③ Flow Direction
- ④ WideBeam transmissions exchanged between the Upstream and Downstream sensors

Reflect mounting automatically corrects for non-axial flow or cross flow conditions. When the exchange of sonic signals occurs by reflection off the far pipe wall as shown above, the average beam versus stream angle will be equivalent to that of an axial flow stream.

3.3 Theory of Operation

Installing/Mounting

4.1 Installation safety precautions

 WARNING
High pressure hazard In applications with working pressures/media that can be dangerous to people, surroundings, equipment or others in case of pipe fracture, we recommend that special precautions such as special placement, shielding or installation of a pressure guard or a safety valve are taken when the sensor is mounted.

4.2 Determining a location

Upstream / Downstream

- Avoid long drop lines downstream from the flow meter to prevent the meter tube from draining (min. pressure: 0.2 Bar).
- Avoid installing the sensor immediately upstream of a free discharge in a drop line.

Location in the system

The optimum location in the system depends on the application

- For liquid applications the presence of excessive gas or air bubbles in the fluid may result in erroneous measurements. Therefore, do not install the flow meter at the highest point in the system, where gas / air bubbles will be trapped. For liquids it is advantageous to install the flow meter in low pipeline sections, at the bottom of a U-section in the pipeline.

4.3 Use according to specifications

"Use according to specifications" covers:

- Use within technical limits.
- Consideration of liquid specifications and references.
- Consideration of specifications as to installation, commissioning and maintenance.
- Operating pressure and temperature must be within the limits indicated on the product label.
- Flow and density must be within the specified limits

Do NOT:

- Use the flow meter as elastic equalization in pipe systems to compensate for e.g. pipe displacement, pipe vibration, expansion, etc.
- Use the flow meter as footboard for installation purposes.
- Use the flow meter as support of external loads like pipes, etc.
- Change the flow meter in any way. For e.g. decomposition of material in connection with processing, welding and use of accessories and spare parts not approved by Siemens.

Note

If the flow meter is not used according to the specifications, the manufacturer cannot be held responsible for any resulting damage.

4.4 Application Guidelines

Basic Requirements

- Determine pipe material and dimensions.
- Avoid vertical pipes flowing in a downward direction.
- Avoid installation of sensors on the top and bottom of horizontal pipes, if possible.
- Select a location with the longest straight run of pipe.
- Identify upstream piping configuration (elbow, reducer, etc.).
- Pipe surface should be smooth and, if necessary, free of paint.
- Avoid pressure reduction components upstream.
- Avoid mounting on or near weld seams.
- Pipe must be full to achieve proper operation.

4.5 AC Battery Charger

The flow meter has an optional battery charger that operates from a 100, 110 or 220 VAC (50 Hz or 60 Hz) power source. It has a universal power input that requires no user switching. *Optional cords can be provided for connection to AC outlets in most countries.*

<p>⚠ CAUTION</p> <p>The 1015BCK-1 Power Adapter/Battery charger is NOT waterproof or water resistant.</p> <p>Exposure to a wet or submerged environment will result in damage to the unit that cannot be repaired and could expose the user to the risk of electric shock.</p> <p>Do not allow it to become wet, or attempt to use it when wet.</p>

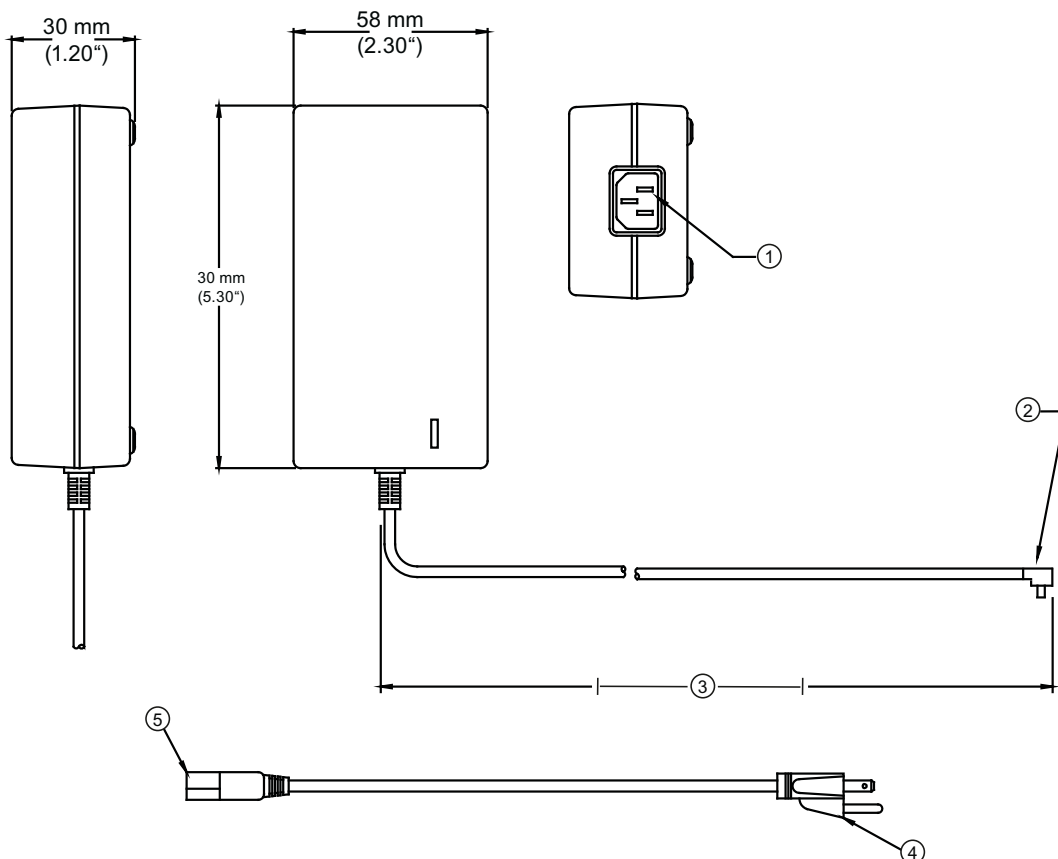

- ① IEC 320 Power Inlet
- ② Connector
- ③ 0,9 meters minimum (3 ft)
- ④ NEMA 5 - 15P (see Power Cord table)
- ⑤ IEC 320 Plug (see Power Cord table)

Figure 4-1 Power Adapter/Battery Charger

Table 4- 1 Power Cord Codes

Assembly P/N	POWER CORD	
	Plug Std.	Rating
1015BCA-1	GEE 7/7	10A / 230VAC
1015BCC-1	A5 3112	10A / 250VAC
1015BCD-1	BS 1363	5A / 240VAC
1015BCJ-1	JIS 8303	12A / 125VAC
1015BCK-1	NEM 5-15P	10A / 120VAC
1015BCL-1	SEV 1011	10A / 250VAC

Connecting

5.1 Transmitter Wiring

5.1.1 Forming the Internal Battery

Battery Operation

All portable systems include battery chargers that operate from an AC voltage source. We strongly recommend that you "form" and charge the battery before operating the system for the first time.

The Charge Indicator LED

A battery status indicator shows the status of its internal battery and charging circuits. The indicator LED color switches between red or green based upon the flow meter operation.

LED	Battery Condition
Green	Trickle charge in progress
Red	Rapid Charge in progress (flow meter must be off)

Forming the Internal Battery

The flow meter uses an internal, rechargeable battery pack designed for a rapid charge cycle (NiMH, 12 VDC, 3200mAH). The batteries have to be "formed" to deliver their optimum operating time, which is approximately 7 hours. This is accomplished by performing a minimum of two complete discharge/charge cycles.

Note

To remove, replace or dispose of the internal battery pack refer to Maintenance and Service section in the instruction manual.

To Produce a Charge/Discharge Cycle:

1. Press the ON keypad to turn the flow meter ON without connecting an external power source. Leave it ON until an automatic shutdown occurs.
2. Connect the AC charger (Page 29) and charge the internal battery with the meter power shut OFF. The charge indicator LED will turn RED (Rapid Charge) for approximately 1 to 2 hours, then turn GREEN (Trickle Charge). Charge the battery for an additional 8 hours or more.
3. Repeat the charge/discharge cycle again. The battery should now be "formed" to provide its maximum operating time.

To maintain the battery "forming," whenever possible, discharge the battery completely before recharging. If the operating time during battery use appears to be unusually short, then a discharge/charge cycle should lengthen the operating time. If this does not correct a short operating time, then the internal battery should be replaced.

Status	Indication	Action
Battery Warning Beeper	Normal operation, periodic audible alarm	Connect a Battery Charger for continued operation.
Battery Discharge	Unit will not turn on (no display screen)	Connect to Battery Charger for at least 1.5 hours before attempting to operate.

See also

Maintenance and service (Page 123)

5.1.2 Connecting AC Power Adapter/Charger

Connecting the 1015BCK-1 (7ME39404PG00) Power Adapter/Charger

1. Connect the AC power cord to the AC cord input of the Power Adapter/Charger.
2. Plug the Power Adapter/Charger connector into the rear panel Auxiliary Power/Battery Charger input connector.
3. Plug the Power Adapter/Charger AC plug into an AC power outlet.

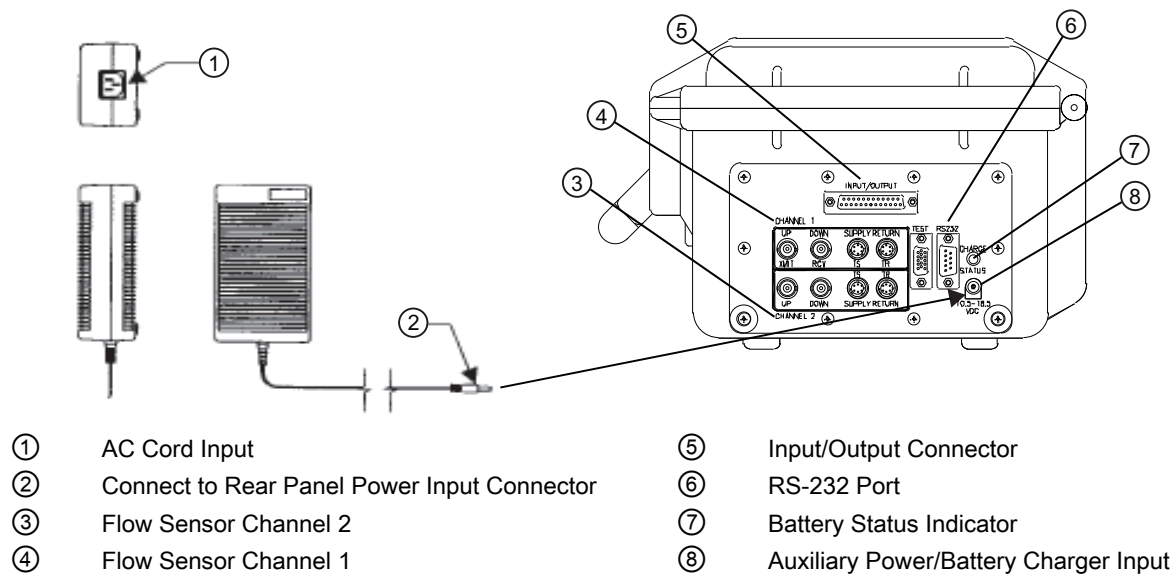

Figure 5-1 Power Adapter/AC-Charger for Dual Channel Flow Meter

5.2 Sensor Wiring

5.2.1 Preliminary Installation Procedures

Reflect and Direct Sensor Mounting

Reflect and Direct mounting modes are supported for clamp-on sensors. The flow meter recommends a mounting mode after analyzing your pipe and liquid data entries.

Note

When installing sensors, do not key in the V/M (Version/Modification) label number as the Sensor Size.

Clamp-on Sensor Mounting Modes

The transmitter recommends a mounting mode after analyzing your pipe and liquid data entries. However, you can install clamp-on sensors in the way that best suits your application and the sensor type you have purchased.

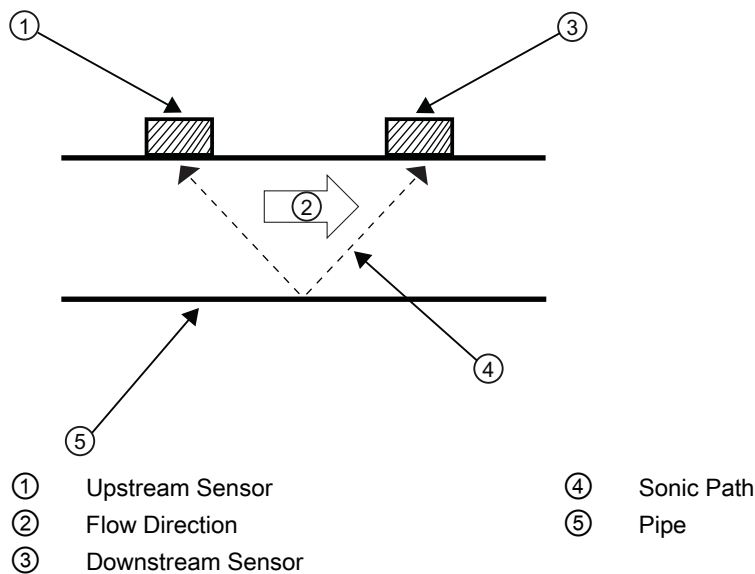

Figure 5-2 Reflect Mount (Pipe shown from above in 12 o'clock position)

Reflect mount is recommended whenever possible. This is the simplest way to mount the sensors. Also, Reflect mount resists abnormal flow profile conditions such as cross-flow within the flow stream. Reflect mount supports the AutoZero function, which zeroes the flow meter automatically without user-participation. In addition, Reflect mount may be the only possibility if conditions do not allow access to the opposite side of the pipe.

Direct mount provides a shorter sonic beam path. This usually improves performance with sonically attenuative liquids or pipe materials. We recommend using Direct mount for plastic pipes. Compared to Direct mounting, Reflect mount requires almost double the amount of mounting length. Therefore, Direct mount may be the only option if the availability of mounting space is limited.

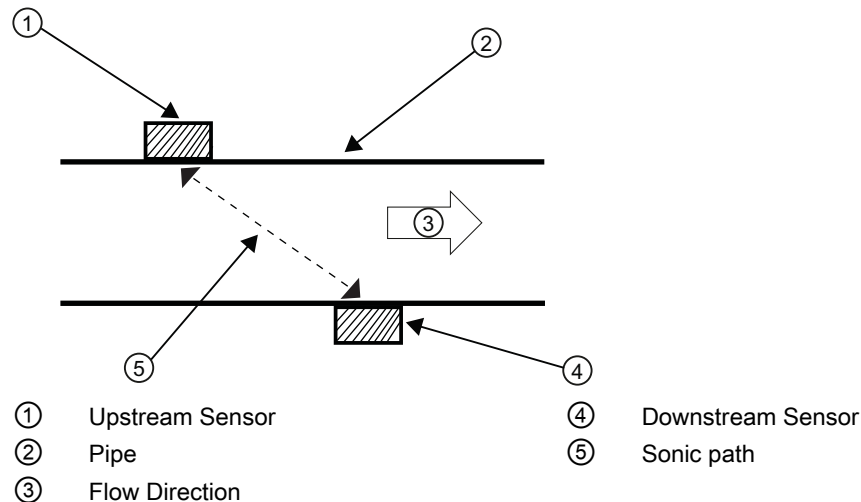

Figure 5-3 Direct Mount (Pipe shown from above in 12 o'clock position)

Mounting Supplies

The following items will be needed to mount the sensors (most are supplied):

- Mounting Frames or Mounting tracks
- Tape, chalk and a ruler or measuring tape
- Spacer Bar
- Mounting Guide (for Direct Mount)
- Ultrasonic coupling compound and/or coupling pads
- Sensors (matched set)

Selecting a location for the sensors

1. Locate the sensors downstream from the center of the longest available straight run. A location ten pipe diameters or greater downstream from the nearest bend will provide the best flow profile conditions.
2. Do not, if possible, install the sensors downstream from a throttling valve, a mixing tank, the discharge of a positive displacement pump or any other equipment that could possibly aerate the liquid. The best location will be as free as possible from flow disturbances, vibration, sources of heat, noise, or radiated energy.
3. Avoid mounting the sensors on a section of pipe with any external scale. Remove all scale, rust, loose paint, etc., from the location.
4. Do not mount the sensors on a surface aberration (pipe seam, etc.)

5. Do not mount sensors from different ultrasonic flow meters on the same pipe. Also, do not run the sensor cables in common bundles with cables from communication equipment, other Siemens systems, or any type of ultrasonic equipment. You can run these cables through a common conduit ONLY if they originate at the same flow meter.
6. Never mount sensors under water, unless you order submersible units and you install them in accordance with factory instructions.
7. Never mount sensors on the top or bottom of a horizontal pipe. The best placement on a horizontal pipe is either the ten o'clock and two o'clock position for Reflect Mode, or one sensor at nine o'clock and one sensor at three o'clock for Direct Mode. Mounting on a vertical pipe is recommended only if flow is in the upward direction. When mounting on a vertical pipe flowing in a downward direction make sure there is sufficient back pressure in the system to maintain a full pipe.

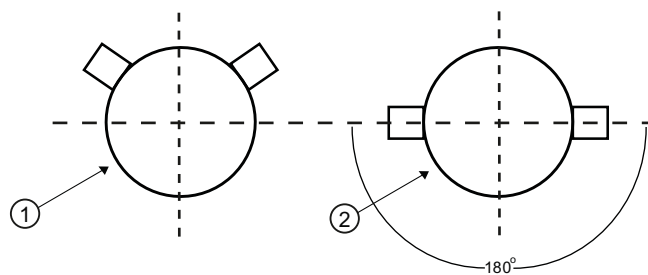

- ① Dual Path, Reflect Mount
- ② Dual Path, Direct Mount

Figure 5-4 Sensor Alignment (Horizontal Plane)

Preparing the Pipe

1. Pick a mounting location with the longest straight run. You must have easy access to at least one side of your pipe. The pipe at the mounting location must remain full, even at zero flow.
2. Decide on your mounting mode (Direct or Reflect). Always use Reflect Mode whenever possible. You may only need to use Direct Mode if your pipe is plastic.
3. After receiving the spacing dimensions from the Installation Menu, prepare the pipe surface. De-grease the surface, if necessary, and remove any grit, corrosion, rust, loose paint, etc. Use abrasive material provided to provide a clean contact surface for the sensors.

Note

Please note that the instructions show vertical mounting for clarity purposes only. Do not install sensors on the top of a pipe.

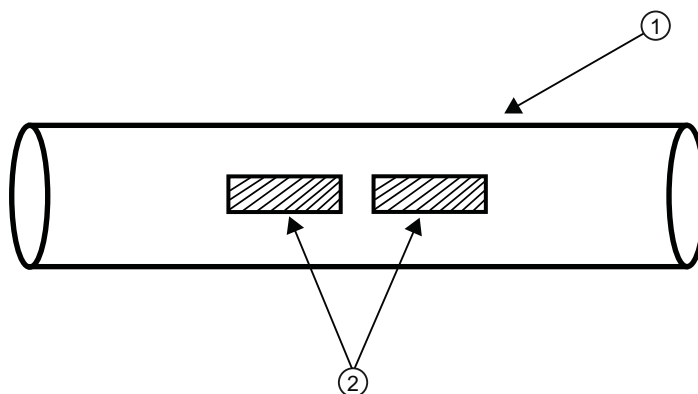

- ① Pipe
- ② Cleaned Areas

Figure 5-5 Pipe Surface Preparation

4. Clean an area 13 mm (1/2-inch) on either side of the sensors.
5. Clean an additional 13 mm (1/2-inch) along the length of the sensors.

5.2.2 Sensor Identification and Selection

Sensor identification

The sensor part number located on the front face provides a detailed identification. For example, the Part Number: *1011HNFS-D1H-UT1-S2* means:

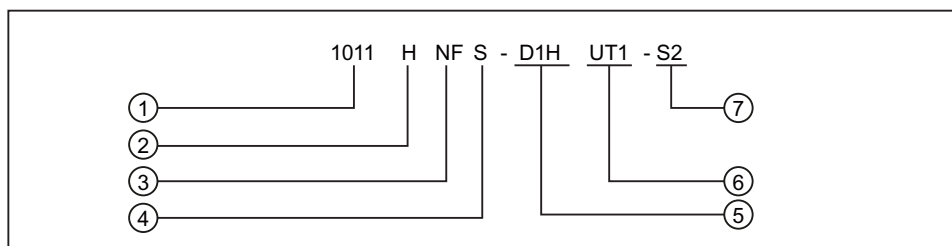

- | | |
|-----------------|-------------------|
| ① Model | ⑤ Size |
| ② Hi Precision | ⑥ Temperature |
| ③ NEMA w/F-Conn | ⑦ Agency Approved |
| ④ Pipe Material | |

Note

Check to make sure that the sensors are a matched set with the same serial numbers and marked with an "A" and "B" (e.g., 19256A and 19256B).

Note

Sensor Model names for Version 3 op systems are as follows: 1011H Hi Precision, 1011 Universal and 991 Universal.

Typical Sensor Labels

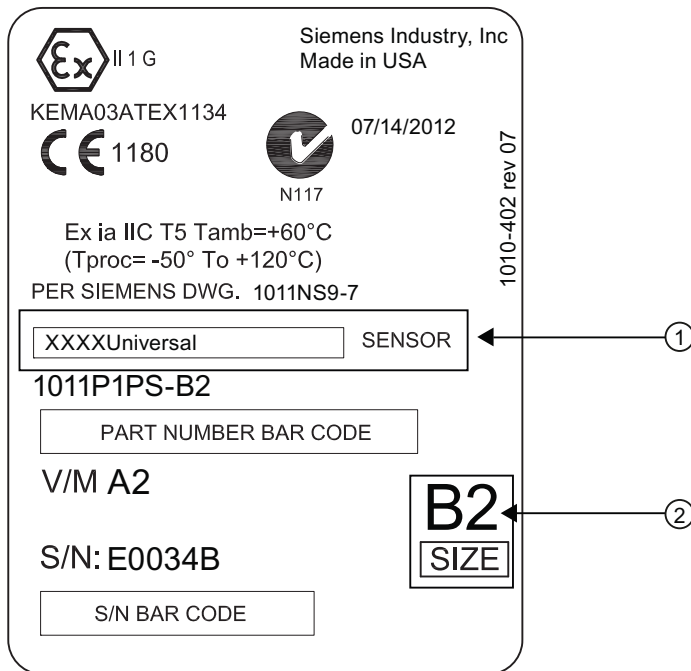

- ① Universal sensor model number
- ② Sensor size

Figure 5-6 Universal Sensor Label

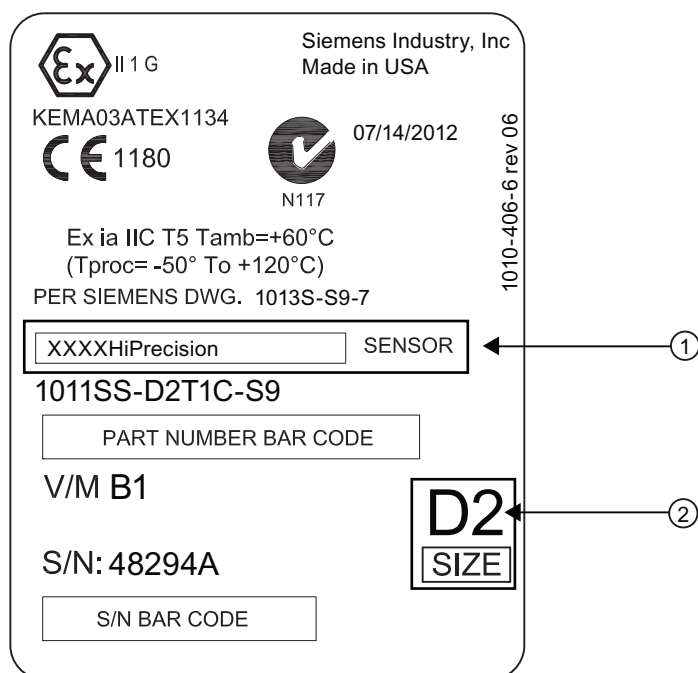

- ① Hi Precision sensor model number
- ② Sensor size

Figure 5-7 Hi Precision Sensor Label

Sensor Selection

Note

The transmitter must be powered up before you can select a sensor model. Refer to Transmitter Wiring (Page 27).

Before selecting sensors proceed to Setting the Parameters (Page 38) and perform the preliminary programming procedures.

5.2.3 Navigating the Menu

Installation Menu Navigation

The Installation Menu Chart is a multi-level structure divided into three columns from left to right		
Level A - lists the major menu categories.		
Level B - list the menu cells associated with Level A. You can enter data into Level B menu cells that are display parameters in a column at the right of the screen.		
Level C - lists the Level B data		
Level A	Level B	Level C
	Recall Site Setup	Pump 1 Pump 2
	Channel Enable	
	Create/Name Site	
	Site Security	
	Delete Site Setup	
	Save/Rename Site	

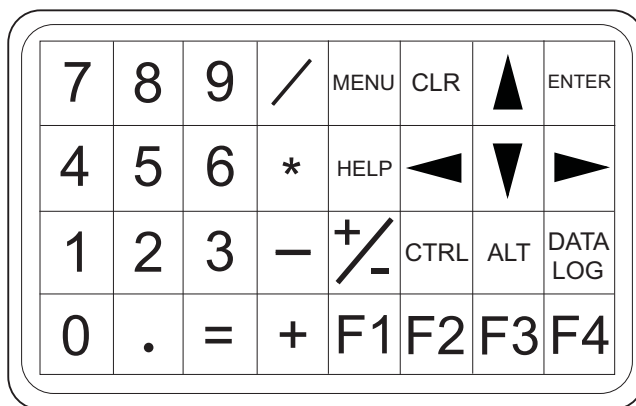

Figure 5-8 Keypad

Note

Use <Left Arrow> key to return to previous menus.

Table 5- 1 Keypad Function Chart

Keys	Description
MENU	Press to activate the Installation Menu.
ENTER	Store numeric data, select from option lists, etc.
Left / Right Arrows	Menu navigation keys move cursor.
Up / Down Arrows	Same as <Left> and <Right> arrows. Scrolls option lists and graphic display screen.
CLR	Erases data or selects list options.
Numbers 0 - 9	Use to type numeric data.
Decimal Point	Use for decimal points in numeric data.
Math Operators	4-function math operations in numeric entry cells.
"F" Keys 1, 2, and 3	Used to start/stop/reset Totalizer.
F4	Caution: used during power up for system reset.
CTRL and ALT	Used as shift keys for alternative key functions.
DATALOG	Triggers immediate Datalogger report.
Plus and Minus [+ / -]	Changes the sign of numeric data.

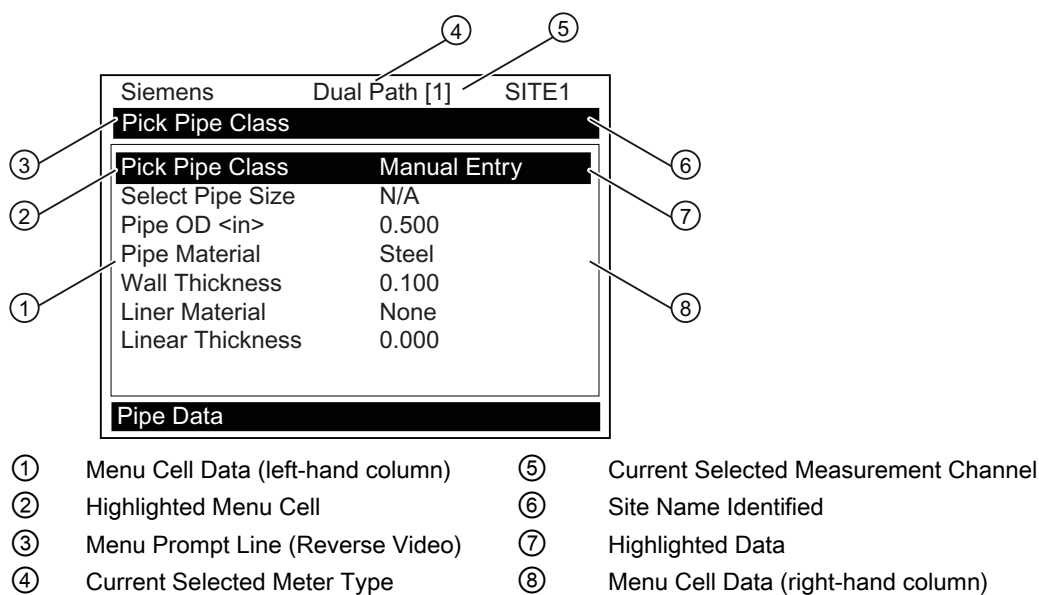

Figure 5-9 Typical Installation Menu Screen

5.2.4 Setting the Parameters

Select Language and Units

Note

Before creating a site select a language and then English or Metric units from the Meter Facilities menu.

Select a Meter Type

1. Press the <MENU> key and select the Meter Type.
2. Press the Right Arrow> and scroll to [2 Chan Energy]

Note

Select [2 Chan Energy] if measuring two different pipes and [2 Path Energy] if sensors are mounted on the same pipe.

3. Press <ENTER> to select. Press <Right Arrow> to select meter function. Press <ENTER>.

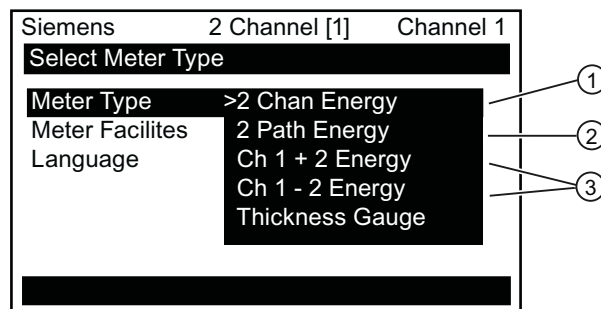

- ① Select for measuring two different pipes. (Not available for all models.)
- ② Select if two sensors are mounted on the same pipe.
- ③ Select for summing or subtracting flow from two different pipes.

Create a Site

1. **Before proceeding make sure that English or Metric units have been selected.**
2. At the [Channel Setup] Menu press <Right Arrow> and then <Down Arrow> to highlight [Create/Name Site]. Press <Right Arrow> to enter a Site name.
3. Press <ENTER> to create Site name (e.g., ABC). (See figure below.)

Note

To set English or Metric units: In the Meter Type menu, scroll to Meter Facilities Menu. Press <Right Arrow> and select desired units. Press <ENTER> to select. Press <Left Arrow> and <Up Arrow> to return to Meter Type menu.

Note

To select letters: Press <Right Arrow> to cursor and then press <Up/Down Arrow> to select letters and numbers. Press <ENTER> when done.

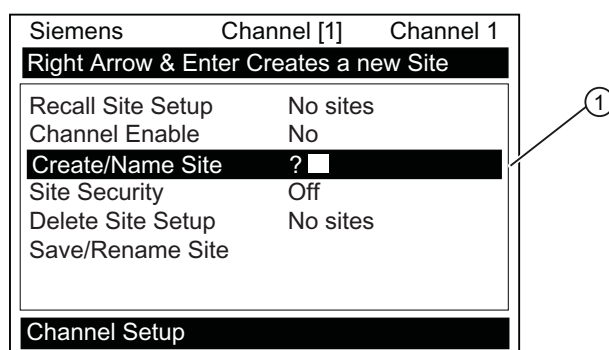

① Insert desired name (8 characters max.)

4. Scroll to [Save/Rename Site]. Press <Right Arrow> then press <ENTER> to save site.
5. Press the <Left Arrow> and return to the [Channel Setup] menu.

Select Pipe Class

Pipe Class is a pre-loaded set of default pipe sizes for various ASA and metric pipes. If the intended pipe is standard the user may select this function to pre-load necessary pipe data, otherwise enter data manually using [Pipe O.D.], [Pipe Material] and [Wall Thickness].

1. Press the <Down Arrow> and then <Right Arrow> to highlight [Pipe Data].
2. Press the <Right Arrow> to [Select Pipe Class]. Press <Right Arrow> again and scroll to desired Pipe Class.
3. Press <ENTER> to select.

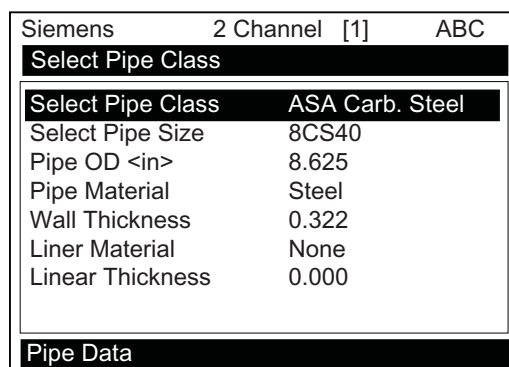

4. Pre-programmed Pipe Size and relevant pipe parameters will appear in menu cells. Press <Right Arrow> and scroll to desired pipe size. Press <ENTER>. Enter dimensions manually if pre-programmed dimensions do not match application.

Note

The DN sizes listed in the [Select Pipe Size] menu option list are referenced to DIN Table 2448. After selecting pipe size, check pipe OD and wall thickness for correct dimensions.

5. Press the <Left Arrow> and return to the [Channel Setup] menu.

Select Liquid Class

1. Press the <Down Arrow> and scroll to [Application Data].
2. Press the <Right Arrow> to select [Liquid Class].
3. Press the <Right Arrow> again and scroll to desired liquid.
4. Press <ENTER> to save selection.

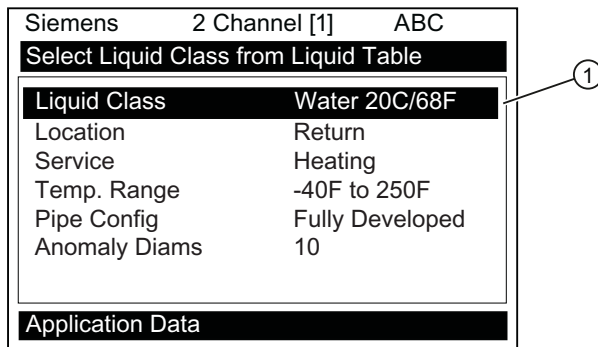

- ① Select from list.

Select Location and Service

1. Scroll down to [Location] and press <Right Arrow>.
2. Press <Right Arrow> to select Location option list.

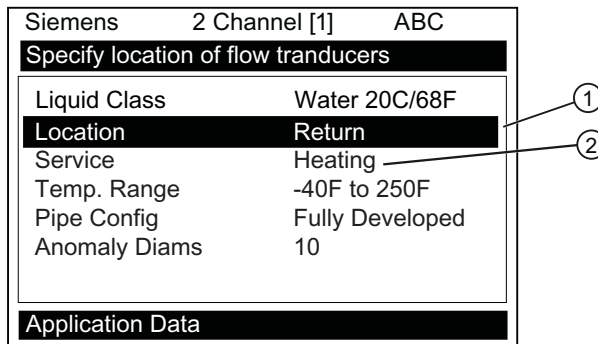

- ① Location option list
- ② Service option list

3. Press <Right Arrow > again and scroll to desired selection.
4. Press <ENTER> to save selection.
5. Cursor will move down and highlight [Service].
6. Press <Right Arrow> to highlight Service option list.
7. Press <Right Arrow> again and scroll to desired selection.
8. Press <ENTER> to save selection.

Select Pipe Configuration

1. Scroll down to [Pipe Config] and press the <Right Arrow>.
2. Select a configuration that approximates the conditions upstream of your sensor mounting location. (Refer to the definitions below.)
3. Press <ENTER> to save selection.

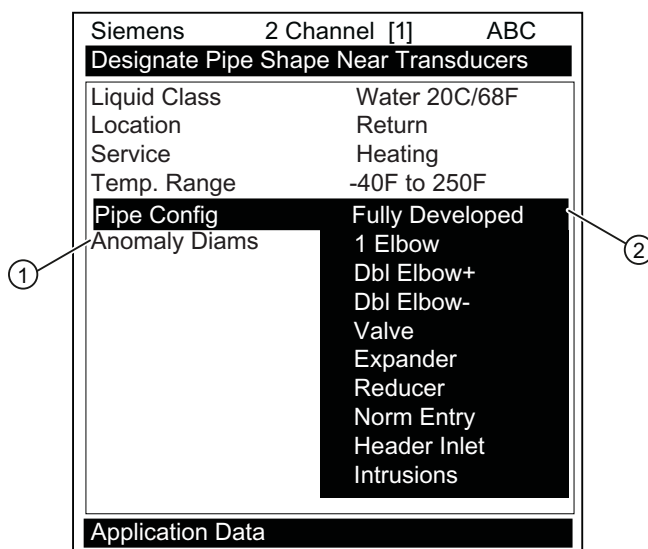

- ① Use this menu cell to enter the number of pipe diameters between the upstream configuration and the sensor installation.
 - ② Use this menu cell to select the pipe configuration that most accurately represents the upstream pipe condition.
4. Press the <Left Arrow> and return to the main menu.

Table 5- 2 Pipe Configuration Option List Definitions

Options	Definitions
Fully Developed	Fully developed flow, as would be expected for very long straight pipe runs or installation downstream of a flow condition.
1 Elbow	Single 90 degree Elbow upstream of sensor installation.
Dble Elbow+	Double out-of-plane Elbows upstream of sensor installation.
Dble Elbow-	Double in-plane Elbows upstream of sensor installation.
Valve	Not available at this time.
Expander	Pipe expansion upstream of sensor installation.
Reducer	Pipe reduction upstream of sensor installation.
Norm Entry	Not available at this time.
Header Inlet	Header or pipe manifold upstream of sensor installation.
Intrusions	Not available at this time.

Sensor Selection

The following is a typical sensor installation procedure.

1. Press <Left Arrow> to return to Main Menu. At the [Meter Type], press the <Right Arrow> and then <ENTER>.
2. The [Channel Setup] menu will appear.
3. Press the <Down Arrow> to select [Install Sensor].
4. Press the <Right Arrow> to [Sensor Model]. Press <Right Arrow> and scroll to select the sensor model number on the sensor label.
5. The drop down menu lists the following sensor selections:
 - 1011 Universal
 - 1011HP-T1 - Usable -40 to 120°C, recommended for Ø Temperature <40°C; Standard.
 - 1011HP-T2 - Usable -40 to 120°C, recommended for Ø Temperature >40°C - <80°C; Named as high temperature.
 - 1011HP-T3 - Usable -40 to 120°C, recommended for Ø Temperature >80°C <120°C; special request.
 - 991 Universal

Note

The meter will automatically recommend a sensor depending on the application data that has been entered.

6. For this example, select the sensor model that appears on the sensor label then press <ENTER>.

Siemens	2 Channel [1]	ABC
Scroll List and select desired Model		
Sensor Model	1011HP-T1	
Sensor Size	D1H	
Sensor Mount Mode	Reflect	
Spacing Offset	Nominal	
Number Index	26	
Spacing Method	Spacer Bar 1012BN	
Ltn Vaue (in)	7.499	
Install Complete	No	
Empty Pipe Set	MTYmatic	
Zero Flow Adjust	Actual Zero	
Install Sensor		

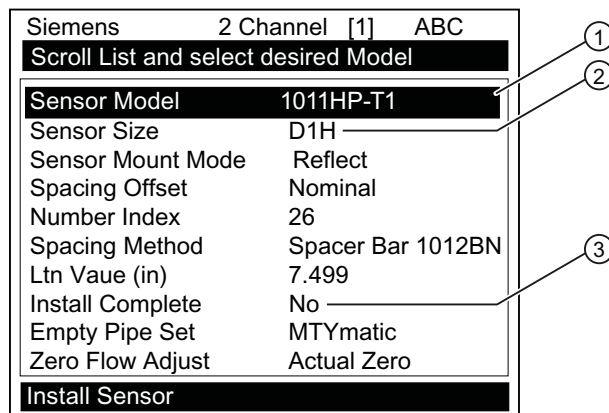

- ① Select based on type.
② Select based on size.
③ **After sensor is mounted select [Install].**

7. To select Sensor Size, press <Right Arrow>. Scroll to select the sensor size that matches the size indicated on the sensor label. Press <ENTER>.
8. At [Sensor Mount Mode], press the <Right Arrow>. Scroll to select [Reflect] or [Direct] mount and then press <ENTER>.
9. **IMPORTANT: Record Spacing Method and Number Index. This data will be used to mount the sensors.**
10. Sensors can now be mounted. Refer to mounting procedures and select the mounting mode desired.
11. **After sensors are mounted scroll to [Install Complete] and select [Install].**

5.2.5 Reflect Mount

Reflect Mount using EZ Clamp and Spacer Bar

The EZ Clamp is a quick and easy way to securely mount sensors on any pipe. The spacer bar eliminates manual spacing measurements and provides rigidity for mounting the sensors while maintaining axial alignment.

Before beginning refer to the EZ Clamp sensor installation diagram example below.

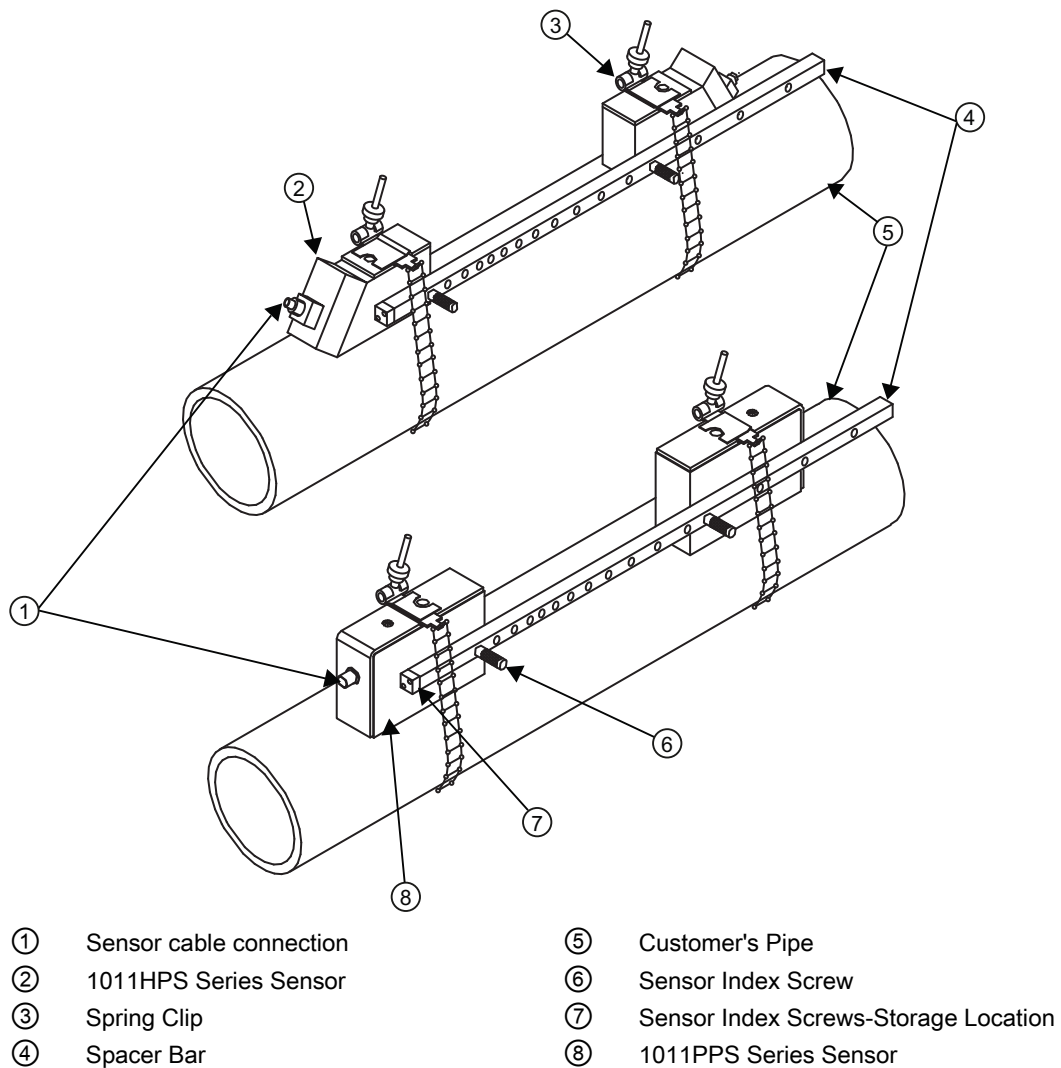

Figure 5-10 Reflect Mount with EZ-Clamp and Spacer Bar

Ltn Menu Cell

This view only menu cell shows the distance in inches or millimeters between the front faces of the sensors along the axis of the pipe. If you are mounting the sensors without a track or spacer bar, you have to space them according to this value. Note that Ltn may be a negative number for direct mount on very small pipes where the sensor spacing overlaps.

Installation Procedure

1. After receiving the Number Index from the Installation Menu, prepare the pipe surface area where the sensors will be mounted. Check to ensure that you have a matched set of sensors. They both should have the same S/N number but marked with either an "A" or "B" (e.g., 100A and 100B).
2. Degrease the surface and remove any grit, corrosion, rust, loose paint, etc.
3. Assemble the sensors to the spacer bar, with the cable connectors facing away from each other as shown above. The spacer bar is attached to a sensor using a sensor index screw.
4. One sensor is attached using the "REF" hole on the spacer bar. The second sensor is attached to the spacer bar at the index hole specified by the Number Index recorded in Step 1.

Note

In some cases, the sensors may have two sets of securing holes. When using the EZ Clamp assembly, use the lower set of holes when attaching the spacer bar.

5. Temporarily position the assembly (in the 10 o'clock position) at the location where it will be mounted. Ensure that this is a smooth area of the pipe without any raised spots (seams, etc.).
6. With a pencil or chalk mark a generous area around each sensor where they contact the pipe. Remove the assembly.
7. Prepare the two areas you marked by degreasing the pipe surface. Remove any grit, corrosion, rust, loose paint or surface irregularities with the abrasive pipe conditioning material provided.
8. Remove the sensor from the spacer bar that was attached through the REF hole. Attach the EZ clamp to the sensor under the spring clip. The adjusting nut knob should be pointing up and on the side opposite the spacer bar. Unscrew the knob until it's at the stop.

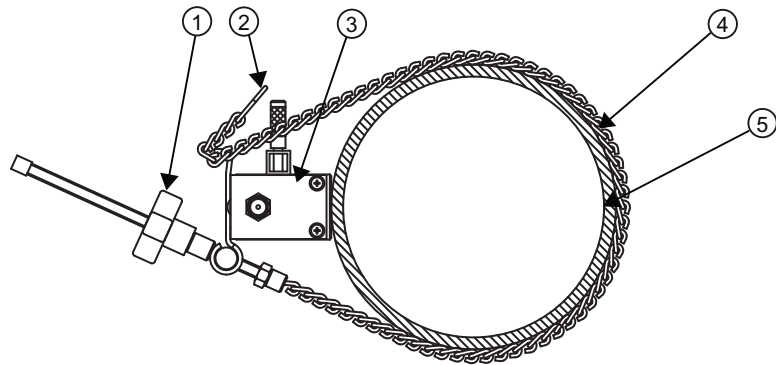

- | | | | |
|---|---------------|---|----------------|
| ① | Adjusting Nut | ④ | Sensor |
| ② | Bit Snap | ⑤ | EZ Clamp Chain |
| ③ | Spacer Bar | ⑥ | Pipe |

Figure 5-11 Sensor Mounting with EZ Clamp and Spacer Bar

Note

To surround larger pipes, link multiple lengths of chain together by mating the Bit Snap and "S" hook.

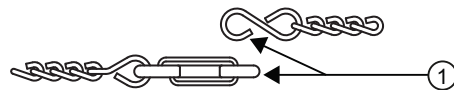

- | | |
|---|--|
| ① | Mate Bit Snap and "S" Hook to extend chain |
|---|--|

Figure 5-12 EZ Clamp S-Hook

- Take sensor and apply a continuous lengthwise 3 mm (1/8-inch) bead of coupling compound across the center of the sensor emitting surface.

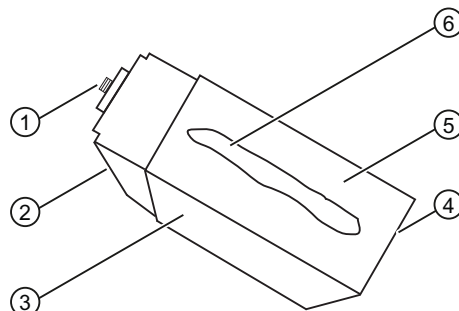

- | | | | |
|---|-----------------|---|-------------------|
| ① | Cable Connector | ④ | Front Edge |
| ② | Angled Edge | ⑤ | Emitting Surface |
| ③ | Sensor | ⑥ | Coupling Compound |

Figure 5-13 Sensor

- Place sensor in the middle of one of the areas you have cleaned. Ensure that the cable connector is facing away from where the other sensor will be placed.
- While holding this sensor in-place, bring the chain around the pipe and attach the closest link onto the hook of the EZ clamp.

12. Tighten the adjusting nut until the chain is just snug around the pipe. Ensure that the chain is straight around the pipe and the sensor contacts the pipe at the white dot just under the front label. Ensure that there is equal space on either side of the dot between the edges of the sensor and pipe.
13. Repeat Steps 7, 8 and 9 for the second sensor leaving it attached to the spacer bar. At the same time that you place it in the middle of the second prepared pipe area, secure the spacing bar to the previously mounted sensor by inserting the sensor index screw through the REF hole on the bar and into lowest hole on sensor (i.e. for those sensors that have two holes).
14. Sight along spacer bar to ensure axial alignment to the pipe. Adjust if necessary. Tighten both chains and ensure that sensors did not move while tightening. Do not over tighten.
15. Observing the upstream and downstream orientation, attach the UP (upstream) and DN (downstream) cables to the sensors and make snug. Attach the other ends to the UP and DN terminals of the flow meter (see figure below).

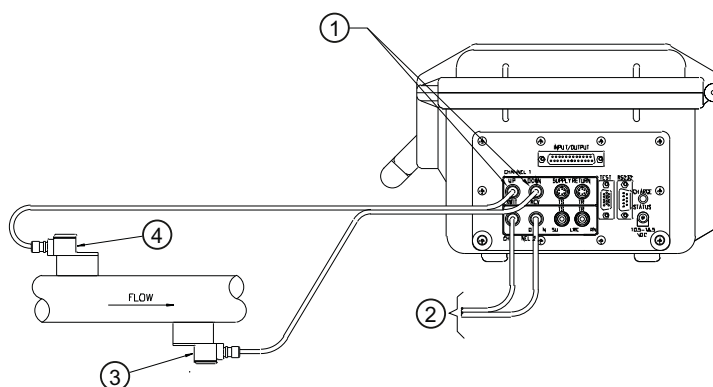

- | | | | |
|---|-----------------------------------|---|-------------------------------|
| ① | CH 1 Flow Sensor Cable Connectors | ③ | Channel 1 - Downstream Sensor |
| ② | To Channel 2 Flow Sensor Set | ④ | Channel 1 - Upstream Sensor |

Figure 5-14 Connecting Sensors to Flow Meter

16. Proceed to Commissioning (Page 69).

5.2.6 Direct Mount

Direct Mount - Installation with EZ Clamp and Spacing Guide

The combination of EZ Clamp and spacer guide is the recommended way to mount Direct Mode sensors. This method ensures that sensors will align exactly 180° from each other and remain spaced the proper distance apart.

For Direct Mode mounting, a spacer bar is used to establish the distance between sensors and a spacing guide is used to locate the sensors at the nine o'clock and three o'clock positions. Should the distance between sensors be beyond the span of a spacer bar, a measuring tape can be used. The Mylar spacing guide comes in various lengths and widths to accommodate most pipe sizes.

Spacing Guide Sizes	
5.08cm x 66.04cm	2" x 26"
5.08cm x 114.3cm	2" x 45"
10.16 cm x 205.7cm	4" x 81"
10.16cm x 393.7cm	4" x 155"
15.2cm x 497.8cm	6" x 196"

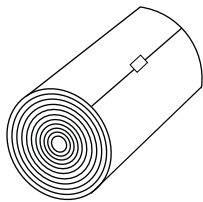
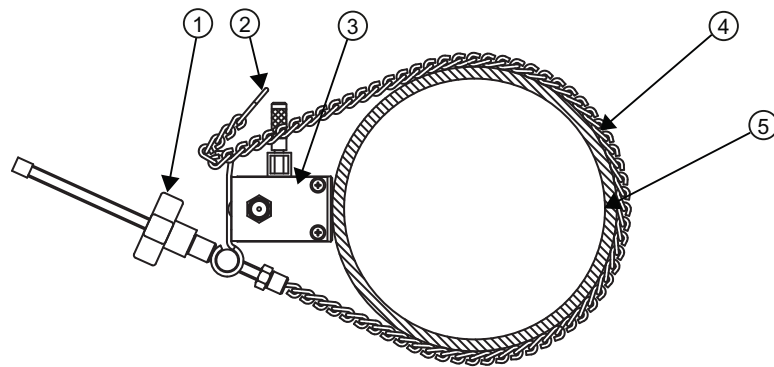

Figure 5-15 Mylar Spacing Guide

Installation Procedure

1. Make a note of the Number Index displayed in the [Install Sensor] menu. Check to ensure that you have a matched set of sensors. They both should have the same S/N number but marked with either an "A" or "B" (e.g., 100A and 100B).
2. Temporarily position one of the sensors on the pipe where you will be mounting it. Ensure that this is a smooth area without any raised areas (seams, etc.) With a pencil or chalk, mark a generous area around all sides of the sensor. Remove the sensor.
3. Prepare the area you marked by degreasing the surface and removing any grit, corrosion, rust, loose paint or surface irregularities with the abrasive pipe conditioning material provided.
4. Attach the EZ Clamp to the sensor under the spring clip. The adjusting nut knob should be pointing up and on the side opposite of the spacer bar. Unscrew the knob until it's at the stop.



- | | |
|-----------------|------------------|
| ① Adjusting Nut | ④ EZ Clamp Chain |
| ② Bit Snap | ⑤ Pipe |
| ③ Sensor | |

Figure 5-16 EZ Clamping Sensor to Pipe

Note

To surround larger pipes, link multiple lengths of chain together by mating the Bit Snap and "S" hook.

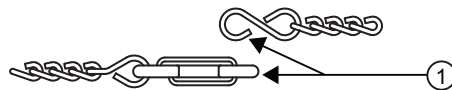

- ① Mate Bit Snap and "S" Hook to extend chain

Figure 5-17 EZ Clamp S-Hook

- Take sensor and apply a continuous lengthwise 3 mm (1/8-inch) bead of coupling compound across the center of the sensor emitting surface.

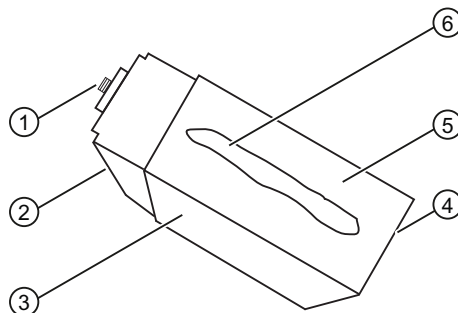

- | | |
|-------------------|---------------------|
| ① Cable Connector | ④ Front Edge |
| ② Angled Edge | ⑤ Emitting Surface |
| ③ Sensor | ⑥ Coupling Compound |

Figure 5-18 Sensor

- Place sensor at the center of the pipe in the middle of one of the areas you have cleaned. Ensure that the cable connector is facing away from where the other sensor will be placed.
- While holding this sensor in place, bring the chain around the pipe and attach the closest cross-link onto the "S" hook of the EZ clamp.

8. Tighten the adjusting nut until the chain is just snug around the pipe. Ensure that the chain is straight around the pipe and the sensor contacts the pipe at the white dot just under the front label. Ensure that there is equal space on either side of the dot between the edges of the sensor and pipe. Adjust if necessary.
9. Tighten chain and ensure that the sensor does not move while tightening. Do not over tighten.
10. Attach the second sensor to the spacer bar at the index hole.

Note

In some cases the sensors may have two sets of holes for securing the spacer bar. When using the EZ Clamp assembly use the lower set of holes when attaching the spacer bar.

11. Do not apply any couplant to the second sensor. First attach the spacer bar assembly, with the second sensor attached to it, to the mounted sensor by inserting an index screw through the REF hole and into the lowest hole on the sensor. Tighten the screw.
12. Visually check that the spacer bar is axially aligned with the pipe.
13. Hold spacer bar assembly in this position and draw a pencil or chalk line along the back edge of the sensor and a dot below the sensor label white dot. See "A" below.
14. Disassemble the spacer bar and second sensor from the mounted sensor. Remove the second sensor from the spacer bar.
15. Use the spacer bar as a straight edge, align the mounted sensor's white dot and the pencil dot and draw a line across the dots (see "B" below). Set spacer bar aside.

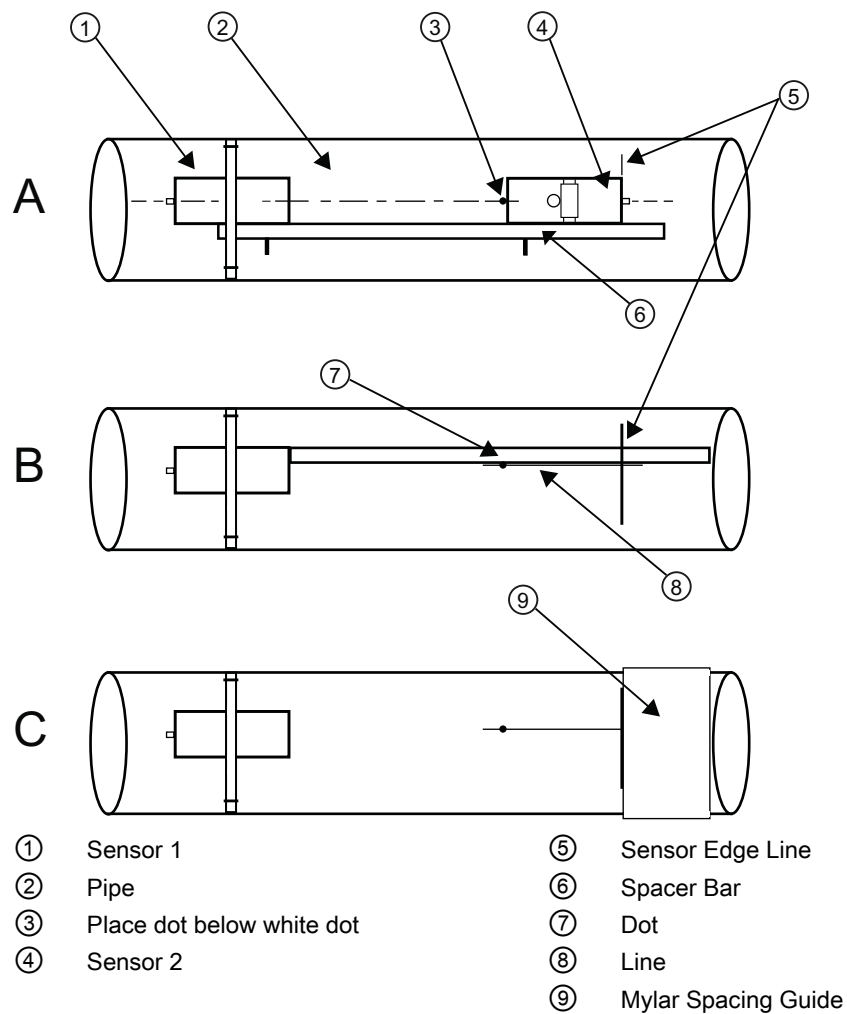

16. Wrap the Mylar spacing guide around the pipe so that the left edge is against the sensor edge mark (see "C" above). Arrange so that one end overlaps the other by at least 8 cm (3 inches). Trim to fit if necessary, but in order to keep the end square, be sure not to trim at the overlapping end.

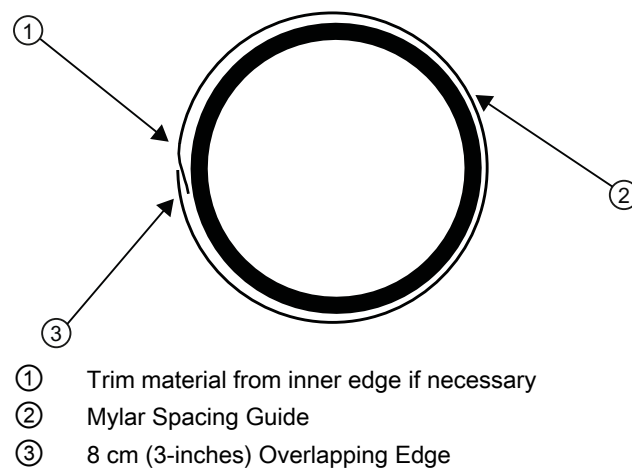
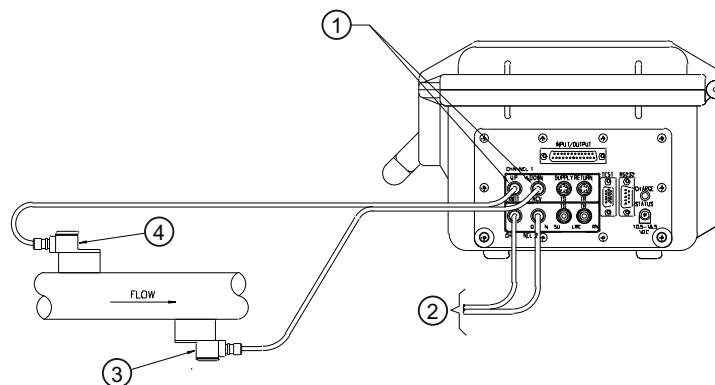

Figure 5-19 Wrapping the Mylar Spacing Guide around the pipe (End View)

23. Attached the EZ Clamp to the sensor under the spring clip. Unscrew the knob until it's at the stop.
24. Apply a continuous lengthwise 3mm (1/8-inch) bead of coupling compound across the center of the sensor emitting surface.
25. Hold the sensor in place and bring chain around pipe and attach to the closest link on the EZ Clamp "S" hook.
26. Tighten the adjusting nut until the chain is just snug around the pipe. Ensure that the chain is straight around the pipe and the sensor contacts the pipe at the white dot just under the front label. Ensure that there is equal space on either side of the dot between the edges of the sensor and pipe. Adjust if necessary.
27. Tighten chain and ensure that the sensor does not move while tightening. Do not over tighten.
28. Observing the upstream and downstream orientation, attach the UP (upstream) and DN (downstream) cables to the sensors and make snug. Attach the other ends to the UP and DN terminals of the flow meter (see figure below).



- | | |
|-------------------------------------|---------------------------------|
| ① CH 1 Flow Sensor Cable Connectors | ③ Channel 1 - Downstream Sensor |
| ② To Channel 2 Flow Sensor Set | ④ Channel 1 - Upstream Sensor |

Figure 5-22 Connecting Sensors to Flow Meter

29. Proceed to Commissioning (Page 69).

5.2.7 1012T Mounting Tracks

Using 1012T Sensor Mounting Tracks

The 1012TP and 1012THP Mounting Tracks provide a rigid mounting platform for Series 1011 Universal or high precision size A or B sensors. The mounting tracks service pipe sizes up to a maximum of 140 mm (5.00") outer diameter. The 1012TP mounting tracks support both Direct and Reflect mounting modes. The transmitter recommends the appropriate sensors, mounting track and mounting mode, based on the pipe data entries.

Installing a 1012T Mounting Track in Reflect Mode

The Sensor Installation procedures show how the automatic selection of sensors, mounting mode and spacing method are established. Examine the figure below, which illustrates a typical [Install Sensor] menu screen. Note the automatic assignment of mounting track part numbers, plus the designation of the Number Index.

Siemens	Dual Path [1]	SITE1
Install Complete?		
Install Path	1	
Sensor Model	1011HP-T1	①
Sensor Size	B3	①
Sensor Mount Mode	Reflect	①
Spacing Offset	Minimum	
Number Index	6	②
Spacing Method	Track 1012TPH	②
Ltn Value (in)	0.581	
Install Complete	No	
Empty Pipe Set	Channel Not Setup	
Zero Flow Adjust	Channel Not Setup	
Install Sensor		

- ① Sensor type, size and mounting mode selection.
- ② Automatic selection of mounting track part number and Number Index.

1. Perform all required menu steps up until the point where you respond to the [Install Complete?] prompt.
2. Make a note of the Number Index. Check to ensure that you have a matched set of sensors. They both should have the same S/N number but marked with either an "A" or "B" (e.g., 100A and 100B).

Note

Index pins are used as stops against each sensor inserted at the reference hole for one sensor and the Number Index hole for the other sensor (see ⑨ in figure below).

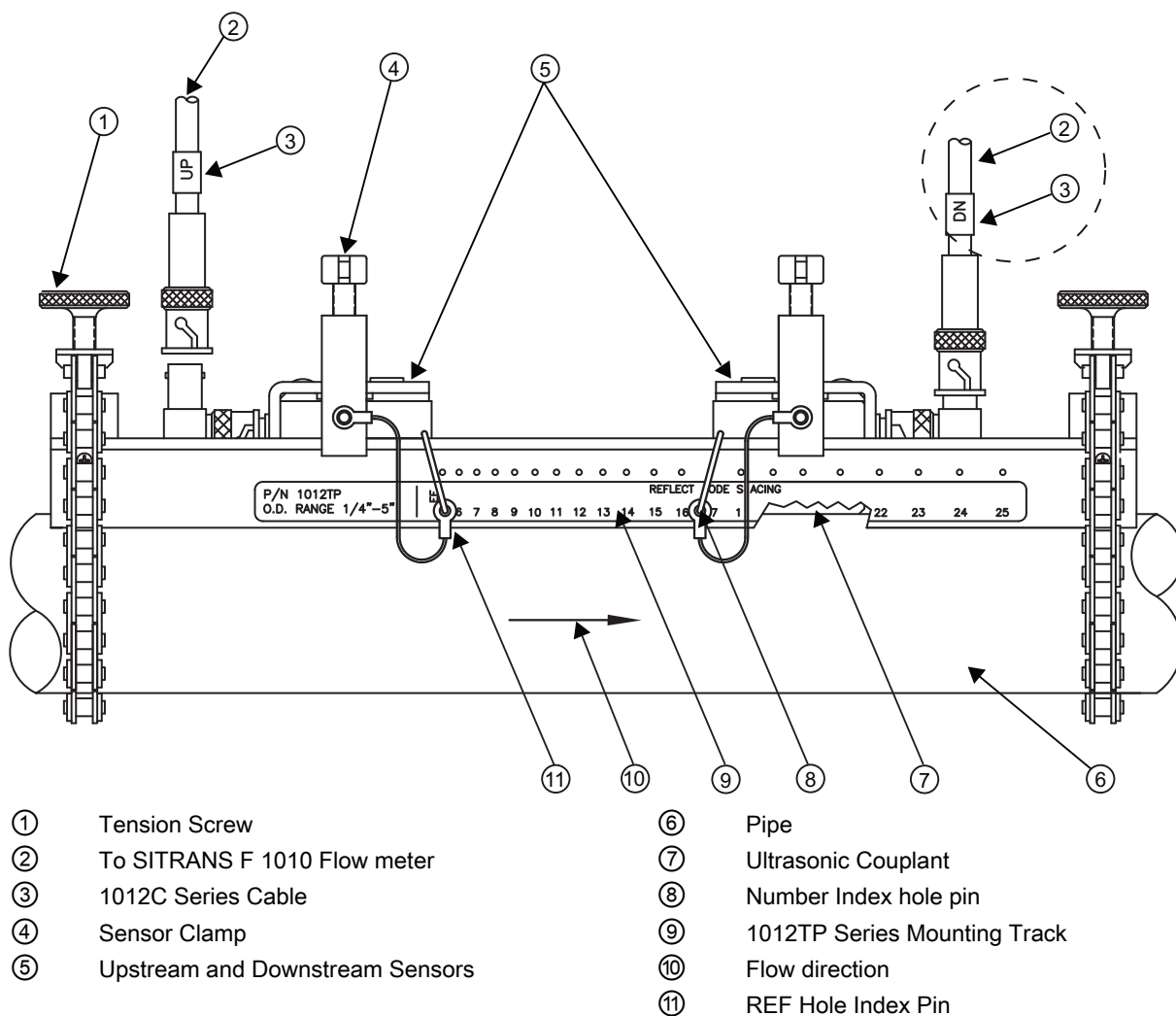
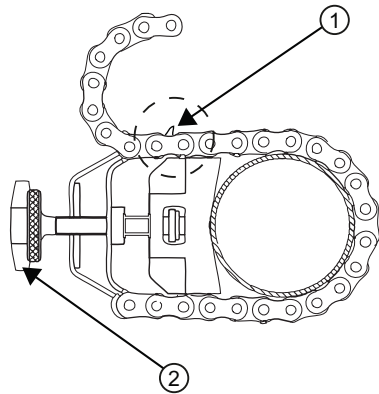

Figure 5-23 Reflect Mount with Model 1012TP Mounting Track (Side View)

3. Place the track rail assembly on the top surface of the pipe at the location where you have determined it will be mounted. Ensure that it is a smooth area without any raised spots or seams.

4. Holding the track assembly in place, loop one of the roller chains under the pipe, pull it around and maintain tension while slipping a link over the tension screw hook. Tighten the tension screw enough to hold the assembly on the pipe, but still allow rotation. Repeat for the other roller chain.



- ① Loop chain over tension screw hook
- ② Chain tension screw

Figure 5-24 Reflect Mode Chain Loop (Front View)

5. Rotate the track rail assembly to the intended mounting position on the pipe, then tighten both tension screws just enough to prevent rotation. Do not over tighten.
6. With pencil or chalk, mark a generous area around the perimeter of the track assembly. Loosen and move the track assembly away from the marked area.
7. Prepare the area you marked by degreasing the surface, if needed, and removing any grit, corrosion, rust, loose paint or surface irregularities with the abrasive pipe conditioning material provided. Clean the pipe of all debris and abrasive particles.
8. Rotate the track into the position that was just cleaned. Insert the index pin into the REF hole.
9. Select a sensor and apply a thin band of couplant compound to the sensor's emitting surface.
10. Place the sensor between the track rails, slightly behind the pin and under the clamping screw assembly. Slide it forward until it butts up firmly against the reference pin.
11. Once the sensor is in place secure it with the sensor clamping screw. Do not over tighten.
12. Repeat procedure for Number Index sensor making sure to insert an index pin into the correct Number Index hole. Refer to the Model 1012TP Mounting Track (side view) figure above.
13. Observing the upstream and downstream orientation, attach the UP (upstream) and DN (downstream) cables to the sensors and make snug. Attach the other ends to the UP and DN terminals of the flow meter.

Installing a 1012T Mounting Track in Direct Mode

The Sensor Installation procedures show how the automatic selection of sensors, mounting mode and spacing method are established. Examine the figure below, which illustrates a typical [Install Sensor] menu screen. Note the automatic assignment of model numbers for the sensor and mounting track, plus the designation of the Number Index.

Siemens	Dual Path [1]	SITE1
Install Complete?		
Install Path	1	
Sensor Model	1011HP-T1	
Sensor Size	B3	
Sensor Mount Mode	Direct	←
Spacing Offset	Minimum	
Number Index	4	←
Spacing Method	Track 1012TPH	←
Ltn Value (in)	0.217	
Install Complete	No	
Empty Pipe Set	Channel Not Setup	
Zero Flow Adjust	Channel Not Setup	
Install Sensor		

① Automatic selection of mounting track part number , mount mode and Number Index

The combination of two Model 1012TP Mounting Tracks and a spacer guide is the recommended way to mount sensors in the Direct Mode. This method ensures that sensors will align exactly 180° from each other and remain spaced the proper distance apart.

The Direct Mount configuration uses a set of two track rail assemblies; one for each sensor, installed 180° apart on the pipe. The set includes:

- Direct Mode Track Assembly - This track rail has number index holes for inserting an index pin to position the other sensor.

Note

Index pins are used as stops against each sensor inserted at the reference hole for one sensor and the Number Index hole for the other sensor (see ⑩ in figure below).

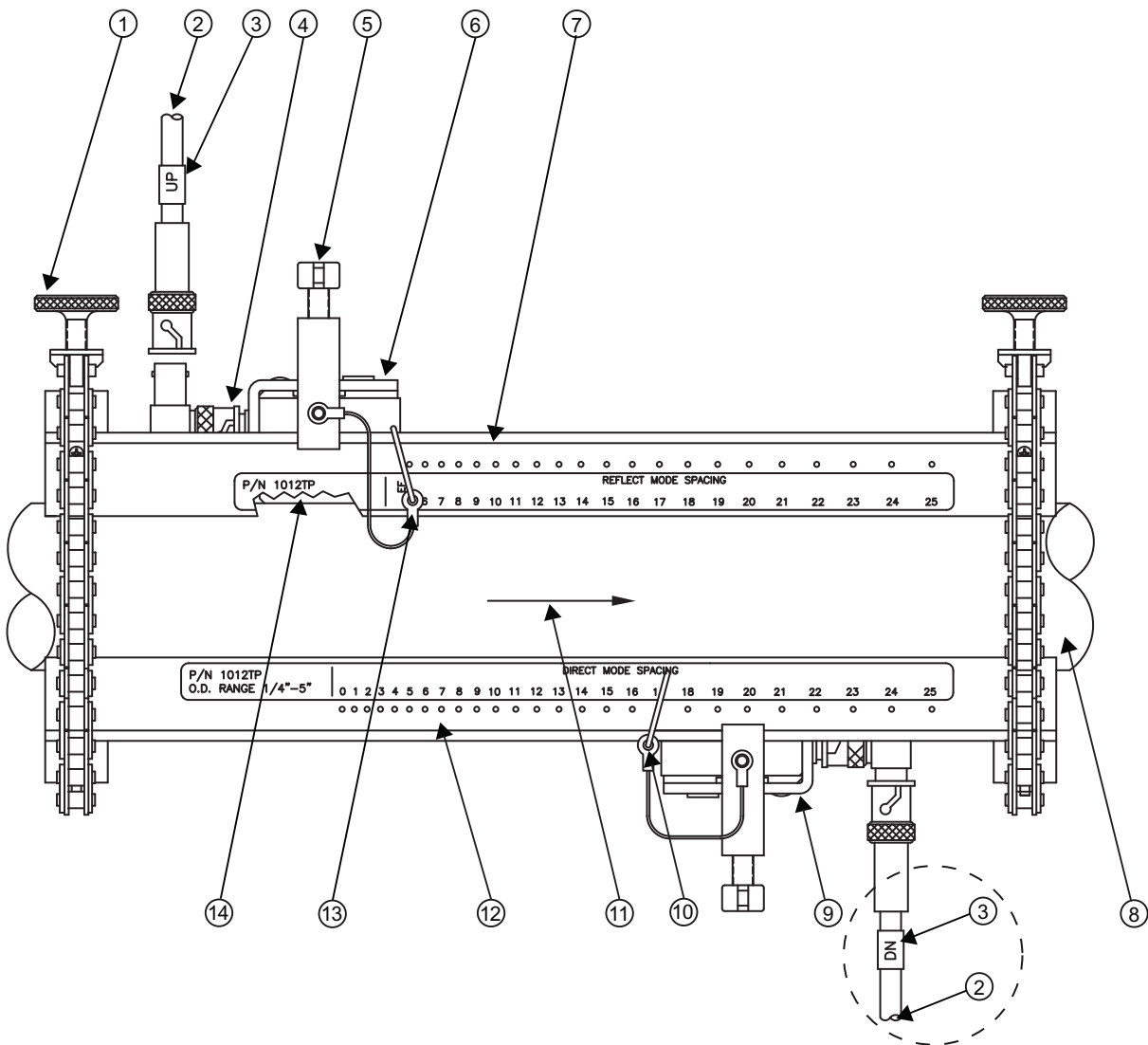

- | | | | |
|---|----------------------------------|---|----------------------------------|
| ① | Tension Screw | ⑧ | Pipe |
| ② | To SITRANS F 1010 Flow meter | ⑨ | 1011PPS Series Sensor Downstream |
| ③ | 1012C Series Cable | ⑩ | Number Index pin hole |
| ④ | Right Angle BNC Adapter | ⑪ | Flow direction |
| ⑤ | Sensor Clamp | ⑫ | 1012TP Series Mounting Track (D) |
| ⑥ | 1011PPS Series Sensor Upstream | ⑬ | REF Hole Index Pin |
| ⑦ | 1012TP Series Mounting Track (R) | ⑭ | Ultrasonic Couplant |

Figure 5-25 Direct Mount 180° opposed with Mounting Tracks

Track Assembly Installation

1. Perform all required menu programming steps up until the point where you respond to the [Install Complete?] prompt.
2. Make a note of the Number Index displayed in the [Install Sensor] menu. Check to ensure that you have a matched set of sensors. They both should have the same S/N number but marked with either an "A" or "B" (e.g., 100A and 100B).

Note

Some sensors require a right-angle adapter. This adapter should be installed before placing the sensors in the tracks.

3. Prepare pipe for the track mounts by degreasing the surface, if needed, and removing any grit, corrosion, rust, loose paint or surface irregularities with the abrasive pipe conditioning material provided.
4. If this is a horizontal pipe, place the track rail assembly against the pipe. While holding track, place second track on pipe directly underneath (180°) and hold together in place.
5. Wrap the chain around the pipe; first onto the centering pin on the bottom track and then onto the hook on the top track.

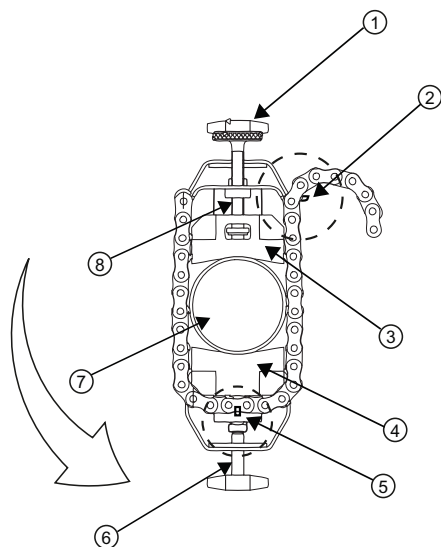

- | | | | |
|---|-----------------------|---|-----------------------------|
| ① | Chain Tension Screw | ⑤ | Centering Pin |
| ② | Chain Hook | ⑥ | Sensor 1 and Clamping Screw |
| ③ | Track Rail Assembly 1 | ⑦ | Pipe |
| ④ | Track Rail Assembly 2 | ⑧ | Sensor 2 |

Figure 5-26 Direct Mount Roller Chain

Note

For a vertical pipe installation, use a tie, tape or bungee cord to hold the two tracks in place while chaining.

6. Finger-tighten the chain Tension Screw to secure the chain and tracks to the pipe.

Positioning Track Assemblies

1. Wrap a length of the Mylar spacing guide around the pipe and against the end of the track assemblies. Ensure that the spacer guide edges on both sides align. Arrange so that one end overlaps the other by at least 8 cm (3 inches). Trim to fit if necessary, but in order to keep the end square, be sure not to trim at the overlapping end.

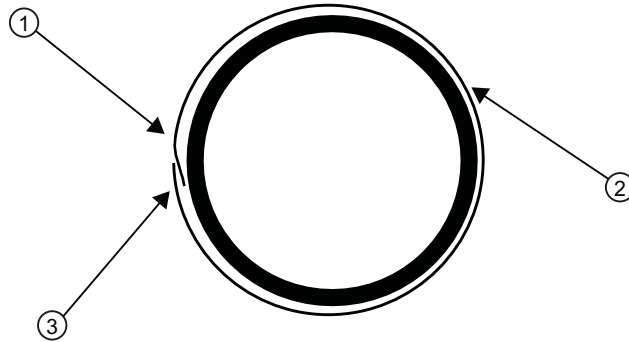

- ① Trim material from inner edge if necessary
- ② Mylar Spacing Guide
- ③ 8 cm (3-inches) Overlapping Edge

Figure 5-27 Wrapping the Mylar Spacing Guide around pipe (End View)

2. Remove the spacer guide. Measure or fold spacer guide to find its halfway distance. Mark a center line and then tape spacer guide to pipe.

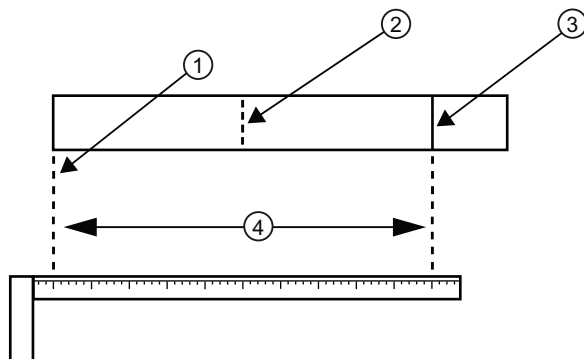

- ① Overlap Edge
- ② Mark (or fold) exactly at half-way point
- ③ Mark on Spacing Guide
- ④ Circumference

Figure 5-28 Finding the Halfway Distance

3. Use the edge of the Spacer Guide as a stop for both tracks to keep them parallel. Adjust tracks as necessary.

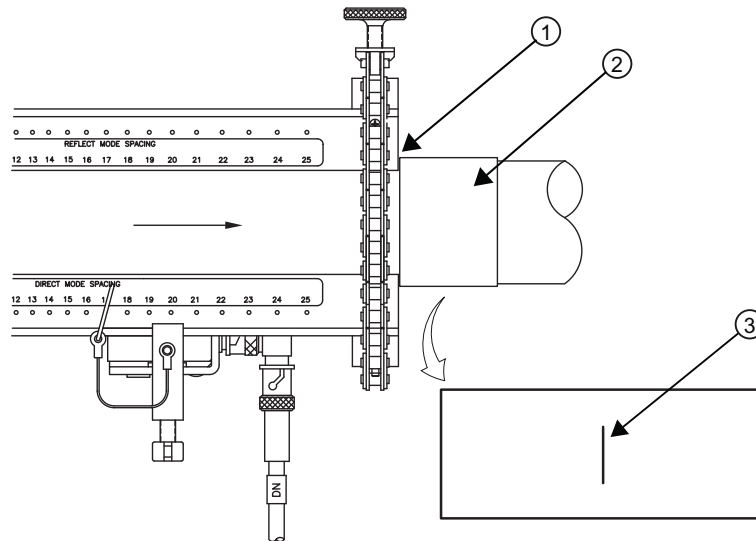

- ① Align tracks with Spacer Guide edge
- ② Mylar Spacer Guide
- ③ Halfway distance of Spacer Guide

Figure 5-29 Track Rail Alignment

4. Loosen the chains enough to allow you to rotate the track assembly until the center of one track aligns with the center line on the Spacer Guide and the center of the other track aligns at the point where the Spacer Guide ends meet. The tracks should now be 180° apart. Tighten both chains but not too tight.

Sensor Installation

1. Insert an index pin into the REF hole of the track marked "Reflect Mode Spacing."
2. Take one of the sensors and insert it between the track rails and to the left of the index pin with the cable connector pointing away from the pin. Move the sensor until the pin stops it. Hold sensor in place. Move sensor clamping screw over the sensor and tighten.

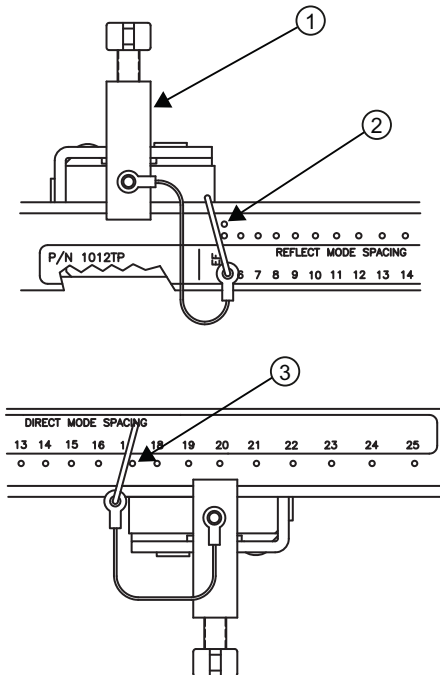

- ① Sensor Clamping Screw
- ② REF hole
- ③ Number Index hole

Figure 5-30 REF and Number Index Pin Locations

3. Insert the other index pin into the correct Number Index hole on the other track marked "Direct Mode Spacing."
4. Insert the second sensor into the track rail with its cable connector pointing away from the pin. Move the sensor until it's stopped by the pin. Move sensor clamping screw over the sensor and tighten.

Note

Remember to install the sensors with the cable connectors facing away from each other.

5. Using a pencil or chalk, mark a generous area around where the sensors contact the pipe.
6. Release the tension on the sensors and remove them.
7. Loosen the chains and rotate the track assembly on the pipe so you can gain access to the areas marked.

8. Prepare the areas you marked by degreasing the surface, if needed, and removing any grit, corrosion, rust, loose paint or surface irregularities with the abrasive pipe conditioning material provided.
9. Rotate the track assemblies into their original position on the pipe. Use the edge of the Mylar guide as a stop for both tracks and keep them parallel. Align each track with the "center line" you previously marked on the Spacing Guide. Tighten tracks securely.
10. This time, before installing each sensor, apply a 3mm (1/8-inch) continuous bead of couplant compound along the center (the long way) of the contact surface of the sensor. Also, keep the sensors lifted slightly from the pipe when installing until the sensor is against the pin; then push down against the pipe.
11. Once the sensors are in place, secure with its clamping screws. Do not over tighten.
12. Observing the upstream and downstream orientation, attach the UP (upstream) and DN (downstream) cables to the sensors and make snug. Attach the other ends to the UP and DN terminals of the transmitter.
13. Proceed to Commissioning (Page 69).

5.3 Zero Flow Adjust Menu

Zero Flow Compensation Methods

Unlike turbine flow meters ultrasonic transit-time flow meters provide active flow measurement right down to zero flow, however, the measurement of the transit-time delta is dependent on the similarity or "match" of the electronics, cables and ultrasonic sensors. Consequently some flow offset (or zero offset) may be present in any installation. To eliminate this residual zero offset Siemens has developed several different methods to insure proper zero flow compensation. The following paragraphs describe each method and when they should be used.

AutoZero

When the 1011HP sensors are mounted in the Reflect Mode configuration the AutoZero routine is automatically invoked at the end of the Initial Makeup. Flow does not have to be stopped to perform AutoZero since only the pipe wall signal is used in determining the zero offset and not the liquid component. The AutoZero routine performs a one-time analysis of the pipe wall component of the ultrasound signal to quantify any residual mismatch in the hardware. Once the AutoZero routine is complete, the system memorizes this measured zero offset and subtracts this value from the flow reading.

Actual Zero

The Actual Zero function simply averages the indicated "zero flow" readings (over a user defined time period) then stores this average value in memory. Under normal operation the indicated flow reading is zero compensated by simply subtracting this memorized value from the uncompensated flow reading. Actual Zero is the most positive method for zeroing the system; however, flow must be stopped with the line blocked (if possible) before invoking this function. If stopping flow is not possible then an alternate zeroing method should be selected.

ReversaMatic

This routine involves swapping the Up and Down sensors on the pipe (while keeping the cables attached) such that the difference in the transit-time change represents the zero offset. The fixed zero offset value is stored in memory in the same manner as described in Actual Zero. This routine would generally be used whenever flow cannot be stopped and the sensors cannot be mounted in the Reflect Mode configuration. Flow must be stable during the entire process.

ZeroMatic

When ZeroMatic is invoked the flow meter first performs the same analysis as described above in the AutoZero routine. However, after this analysis is complete the flow meter continues to interrogate the pipe wall signal and update the zero offset value under normal operation, such that the flow meter dynamically compensates for changing conditions which would normally result in zero drift. ZeroMatic will only operate with the sensors mounted in the Reflect Mode configuration and is recommended for applications which experience large temperature extremes.

Note

Invoking ZeroMatic will clear any existing "fixed" or memorized zero offset. If any zero offset remains after flow is stopped, an Actual Zero can be performed without interrupting ZeroMatic operation. To disable ZeroMatic, invoke it again, but then press <Left Arrow> to abort the installation.

Note

The ZeroClr command only resets the memorized zero offset registers not those set when the AutoZero routine is invoked.

Using Actual Zero

Note

Flow must be stopped with the line blocked (if possible) before invoking this function.

To invoke Actual Zero:

1. Access the [Zero Flow Adjust] option list by pressing <Right Arrow>.
2. Press <ENTER>. A pop-up window prompts you to set the current flow rate (in selected rate units) to equal zero (0.000).

Note

If a flow offset is desired (i.e., to test analog outputs) then press <Right Arrow> to enable numeric entry.

3. Press <ENTER> to start the Actual Zero process.

When you send the command, the flow meter analyzes the current flow rate for up to sixty seconds, integrating (averaging) the data for the best zero correlation. During this time, the menu prompt at the top of the display screen shows a timer that counts from zero to sixty. You can allow zero averaging for the entire period, or cancel the process at any time by pressing the <ENTER> key. This controls the amount of data the flow meter averages to obtain a zero level.

Using ReversaMatic

If site conditions do not permit stopping the flow rate at the mounting location, and you do not know the current flow rate, then you can use the ReversaMatic routine to establish the zero flow level. You should perform the ReversaMatic procedure as quickly as possible to ensure that the flow rate remains constant throughout the procedure.

To invoke ReversaMatic:

1. To access the [Zero Flow Adjust] option list press <Right Arrow>.
2. Move the cursor to [ReversaMatic]. Press <ENTER> to invoke the routine.
3. The flow meter begins to measure the positive flow rate. "Positive" flow refers to flow moving from upstream sensor location to the downstream sensor location. Note top prompt line shows: **Reversamatic Action**
4. Upon completion, the flow meter beeps and the display screen shows: **Reverse Sensors / Press <ENTER>**
5. Now remove then remount the upstream and downstream sensors in their reversed positions. Mount the Up sensor (without removing its cable) in the Down sensor/cable location. Mount Down sensor with its cable in the Up sensor/cable location. When remounting the sensors, couple them to the pipe properly. Press <ENTER> (after re-installing the sensors).

6. The flow meter measures the negative flow rate briefly, then beeps and repeats the prompt:
7. Now remount the sensors for normal operation (in their original orientation). When remounting sensors, couple them to the pipe properly. Press <ENTER> (after re-installing the sensors).

This completes the ReversaMatic procedure. The system's zero accuracy will be very close to that obtainable using the Actual Zero method, providing flow remained constant during this procedure.

NOTICE

Preventing Flow Mis-Registration

A caution on the use of upper and lower flow limits (used to prevent flow mis-registration) prior to using the Reversal Zero technique (ReversaMatic): If the negative flow rate that the flow meter reads in the step during which the sensors are reversed is more negative than the lower flow limit, the meter will re-register positive and the Reversal Zero cycle will thus be corrupted.

Therefore, postpone the installation of upper and lower flow limits until the reversal zero procedure is executed successfully. For pipes that combine large diameters with very high flow velocities, it may be necessary to move the upper and lower flow limits out of the way until the reversal zero is completed. Moreover, pipes of this size frequently have excellent intrinsic zero performance and may not even need zeroing.

ZeroMatic (optional function)

Note

ZeroMatic is used in the Reflect Mode only. Invoking ZeroMatic clears any existing fixed zero offset.

Use this menu cell to select the ZeroMatic option. If conditions permit the use of the Auto Zero function then the ZeroMatic option can be used as well.

To select and enable the ZeroMatic option:

1. In the [Install Sensor] menu, press <Up Arrow> to scroll to the [Zero Flow Adjust] menu cell.
2. To access the [Zero Flow Adjust] option list press <Right Arrow>.

Note

If ZeroMatic is not running, the [Actual Zero] menu item will be displayed next to the [Zero Flow Adjust] menu cell.

3. Select the [ZeroMatic] menu cell by pressing <Up/Down Arrow> then press <ENTER>.

When the Initial Makeup of ZeroMatic is complete the screen will return to the [Install Sensor] menu and automatically highlight [Operation Adjust], which is the next menu cell.

To disable the ZeroMatic function:

1. Select the [Install Sensor] menu cell from the [Dual Path Flow] menu.
2. Scroll down to the [Zero Flow Adjust] menu cell by pressing <Up/Down Arrow>.

Note

The highlighted [ZeroMatic] menu item is the only indication that ZeroMatic is functioning.

3. Invoke the ZeroMatic initial makeup procedure as previously described above.
4. While ZeroMatic initial makeup is running, press <Left Arrow> to abort the process thereby disabling the function.
5. The screen will return to the [Dual Path Flow] menu and highlight the [Operation Adjust] menu cell.

Commissioning

6.1 General requirements

Before commissioning it must be checked that:

- The device has been installed and connected in accordance with the guidelines provided in chapter 4 "Installing / Mounting (Page 23)" and 5 "Connecting (Page 27)"

6.2 Commissioning

 WARNING
Hazardous Voltage Certain parts inside the transmitter carry dangerous high voltage and may result in serious injury. Turn power off before working on transmitter.

 CAUTION
Power Source may be damaged Connection to the incorrect power source will result in damage to the unit and may result in serious injury. Confirm that one of the following power sources is connected: internal battery pack or Power Adapter / Battery Charger.

1. Apply power.
2. Within 10 seconds of power-up the main display will become active and a typical Siemens graphic will appear briefly. The screen also identifies the software version of the unit as shown below.



① Software operating system version

3. The transmitter is ready to report flow. Press <MENU> key twice to display flow.

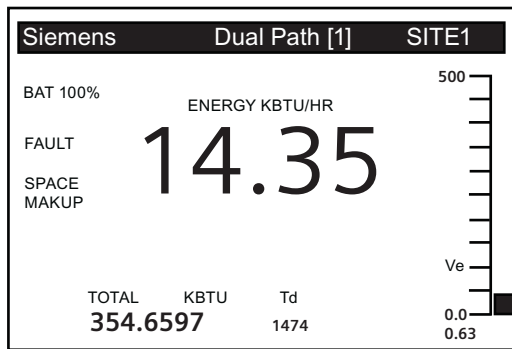

6.3 Empty Pipe Set

The flow meter performs the MTYmatic routine automatically during its Initial Make-up to establish a standard setting for the Empty Pipe alarm. This process is normally sufficient for setting this parameter. The [Empty Pipe Set] option list allows you to re-invoke MTYmatic, use an Actual MTY routine (if application conditions allow you to empty and refill the pipe) or use the Set Empty routine to set the empty pipe threshold by direct numeric entry.

Actual MTY Command

If application conditions allow you to empty and refill the pipe, then you may choose to perform the Actual Empty procedure; however, it is not required to do so.

Note

IMPORTANT

NEVER perform the Actual MTY procedure if the pipe can not be emptied.

To use the Actual MTY command:

1. From [Channel Setup] scroll down to [Install Sensor].
2. Press the <Right Arrow> to access the [Empty Pipe Set] option list.
3. Press the <Down Arrow> to [Actual MTY] then press <ENTER>.
 - **Empty Pipe Press [ENT]** appears on the menu prompt line.

Siemens	2 Channel [1]	ABC
Empty Pipe Press [ENT]		
Sensor Model	1011HP-T1	
Sensor Size	D1H	
Sensor Mount Mode	Reflect	
Spacing Offset	Normal	
Number Index	26	
Spacing Method	Spacer Bar 1012BN	
Ltn Value (in)	7.499	
Install Complete	Set Empty	
Empty Pipe Set	MTYmatic	
Zero Flow Adjust	>Actual MTY	
Install Sensor		

4. Empty the pipe completely, then press <ENTER>.
 - **Fill Pipe Press [ENT]** appears on the menu prompt line.

Siemens	2 Channel [1]	ABC
Fill Pipe Press [ENT]		
Sensor Model	1011HP-T1	
Sensor Size	D1H	
Sensor Mount Mode	Reflect	
Spacing Offset	Normal	
Number Index	26	
Spacing Method	Spacer Bar 1012BN	
Ltn Value (in)	7.499	
Install Complete	Set Empty	
Empty Pipe Set	MTYmatic	
Zero Flow Adjust	>Actual MTY	
Install Sensor		

5. Refill the pipe completely, then press <ENTER>.

Using the MTYmatic command

You can repeat MTYmatic (performed during the Initial Makeup) to correct an inaccurate Actual MTY setting if conditions do not allow you to repeat the Actual Empty procedure.

Note

IMPORTANT

Only use the MTYmatic procedure when the pipe is full.

To start MTYmatic:

1. From [Channel Setup] scroll down to [Install Sensor].
2. Press the <Right Arrow> to access the [Empty Pipe Set] option list.

Siemens	2 Channel [1]	ABC
Set Empty Pipe Detection Threshold		
Sensor Model	1011HP-T1	
Sensor Size	D1H	
Sensor Mount Mode	Reflect	
Spacing Offset	Normal	
Number Index	26	
Spacing Method	Spacer Bar 1012BN	
Ltn Value (in)	7.499	
Install Complete	Set Empty	
Empty Pipe Set	>MTYmatic	
Zero Flow Adjust	Actual MTY	
Install Sensor		

3. Move the cursor next to [MTYmatic] press the <Right Arrow>.
4. To invoke MTYmatic press <ENTER>.

Using the Set Empty command

Use [Set Empty] to enter a number that represents the signal strength level consistent with an empty pipe. [Set Empty] uses non-linear scaling. There is no direct correlation between the number you enter and any standard amplitude unit. If you set the number too low, the meter may not detect a true empty pipe. If you set it too high, it could trigger the empty pipe alarm, suspending flow measurement, even though the liquid is flowing.

To enter an Empty Pipe Alarm Threshold:

1. From [Channel Setup] scroll down to [Install Sensor].
2. Press the <Right Arrow> to access the [Empty Pipe Set] option list.
3. Press <Up Arrow> to move the cursor to [Set Empty].

Siemens	2 Channel [1]	ABC
Set Empty Pipe Detection Threshold		
Sensor Model	1011HP-T1	
Sensor Size	D1H	
Sensor Mount Mod	Set Empty	
Spacing Offset	= 5	
Number Index	26	
Spacing Method	Spacer Bar 1012BN	
Ltn Value (in)	7.499	
Install Complete	>Set Empty	
Empty Pipe Set	MTYmatic	
Zero Flow Adjust	Actual MTY	
Install Sensor		

4. Press <ENTER>. The current empty threshold number appears in a pop-up window.
5. Use the numeric keys to type a new Set Empty number.
6. To store the Set Empty number press <ENTER>

6.4 Installation Menus

FUE1010 Installation Menu Chart

Use <Left>, <Right>, <Up> and <Down> arrow buttons to navigate the menu between levels and sub menus.

For example: To navigate to [Sensor Size]:

1. Press <MENU> to return to Level A.
2. Press <Right Arrow> to Level B (2-Chan Energy) then press <ENTER> until you reach Level E.
3. Scroll using <Down Arrow> to [Install Sensor].
4. Press <Right Arrow> to Level D.
5. Scroll using <Down Arrow> to [Sensor Size].
6. Press <ENTER> select size from list.

Note

Menu items in bold are required entries to establish operation.

6.4 Installation Menus

Level A	Level B	Level C	Level D	Level E	Level F	Level G	Level H
Meter Type	2-Chan Energy	Channel 1/2 Clamp-on	FastStart Setup	Pick Pipe Class	Enter From List		
	2 Path Energy	Reflexor		Select Pipe	N/A		
	Ch 1+2 Energy			Install Sensor	Sensor Model	Enter From List	
	Ch 1-2 Energy				Sensor Size	Enter From List	
	Thickness Gauge				Sensor Mount Mode	Enter From List	
					Spacing Offset	Enter From List	
					Number Index	View Only	
					Spacing Method	View Only	
					Ltn Value (in)	View Only	
					Install Complete	No/Install	
					Empty Pipe Set	Enter From List	
					Zero Flow Adjust	Enter From List	
			Full Site Setup	Channel Setup	Recall Site	Enter From List	
					Channel Enable	Enter From List	
					Create/Name Site	Enter From List	
					Site Security	On/Off	
					Delete Site	Enter/Clear Site Name	
					Save/Rename Site	Enter From List	
				Pipe Data	Pick Pipe Class	Enter From List	
					Select Pipe Size	Enter From List	
					Pipe OD (in)	Numeric Entry	
					Pipe Material	Enter From List	
					Wall Thickness	Numeric Entry	
					Liner Material	Enter From List	
					Liner Thickness	Numeric Entry	
				Application Data	Liquid Class	Select Liquid	Enter From List
						Estimated Vs MS	Numeric Entry
						Viscosity (cS)	Numeric Entry
						Density S.G.	Numeric Entry
					Location	Return/Supply	

Level A	Level B	Level C	Level D	Level E	Level F	Level G	Level H
					Temp. Service	Heating/Cooling/ Heat Pump	
					Temp. Range	Enter From List	
					Pipe Config	Enter From List	
					Anomaly Diams	Numeric Entry	
				Install Sensor	Sensor Model	Enter From List	
					Sensor Size	Enter From List	
					Sensor Mount Mode	Enter From List	
					Spacing Offset	Enter From List	
					Number Index	View Only	
					Spacing Method	View Only	
					Ltn Value	View Only	
					Install Complete	No / Install	Select Install
					Empty Pipe Set	Enter From List	
					Zero Flow Adjust	Enter From List	
				Operation Adjust	Damping Control	Time Average / SmartSlew	
					Energy Deadband	Numeric Entry	
					Deadband Control	Numeric Entry	
					Memory/Fault Set	Fault/Memory	
					Memory Delay (s)	N/A	
				Flow/Total Units	Energy Units	E Rate Units	Enter From List
						E Rate Scale	Enter From List
						Energy Tot Units	Enter From List
						Energy Tot Scale	Enter From List
						Energy Tot Res	Enter From List
						Energy Tot Mode	Enter From List
						CE Method	Enter From List
					Volume Units	Flow Vol. Units	Enter From List
						Flow Time Units	Enter From List
						Flow Disp. Range	Enter From List
						Flow Disp. Scale	Enter From List
						Total Vol. Units	Enter From List
						Totalizer Scale	Enter From List

6.4 Installation Menus

Level A	Level B	Level C	Level D	Level E	Level F	Level G	Level H
						Total Resolution	Enter From List
						Totalizer Mode	Enter From List
						Batch/Sample Tot	Numeric Entry
				Span/Set/Cal	Span Data	Enter From List	
					Set Alarm Levels	Enter From List	
					Calib. Flowrate	Intrinsic	
						Kc	
						MultiPoint	
				Display Setup	Select Data	Enter From List	Display Setup
					Data Display	Enter From List	
					Time Base	Enter From List	
					StripChart Clear	No/Yes	
				Logger Setup	Logger Mode	Enter From List	Logger Setup
					Logger Data	Enter From List	
					Logger Interval	Enter From List	
					Logger Events	Enter From List	
					Display Logger	Enter From List	
				I/O Data Control	Analog Out Setup	Enter From List	I/O Data Control
					Relay Setup	Relay 1,2	
					Analog Inp Setup	Enter From List	
				Diagnostic Data	Energy Data	Enter From List	Diagnostic Data
					Flow Data	Enter From List	
					Application Info	Enter From List	
					Liquid Data	Enter From List	
					Site Setup Data	Enter From List	
					Test Facilities	Enter From List	
					Print Site Setup	No/Yes	
					Site Created:	View Only	
Meter Facilities	Preferred Units	English					
		Metric					
	Table Setups	Pipe Table	Create/Edit Pipe	Enter From List			
			Delete Pipe	Enter From List			
		Sensor Type	Enter From List				

Level A	Level B	Level C	Level D	Level E	Level F	Level G	Level H
	Logger Control	Display Logger	Off/Line Wrap No Line Wrap				
		Output Logger	Yes/No				
		Circular Memory	Yes/No				
		Est LogTime Left	View Only				
		Clear Logger	Yes/No				
	Memory Control	Log Memory Left	View Only				
		Memory Map	Yes/No				
		Defragment	Yes/No				
	Analog Out Trim	Trim Io1	Operate / Trim @ 4mA				
		Trim Io2	Operate / Trim @ 4mA				
		Trim Vo1	Operate / Trim @ 2V				
		Trim Vo2	Operate / Trim @ 2V				
		Trim Pgen1	Operate / Trim @ 1Khz				
		Trim Pgen2	Operate / Trim @ 1Khz				
	RTD Calibrate	Ch1 Ts-RTD1	Factory / User Cal				
		Ch1 Tr-RTD2	Factory / User Cal				
		Ch2 Ts RTD3					
		Ch2 Tr RTD4					
	Clock Set	Date (MM.DD.YY)	Edit Date				
		Time (HH.MM)	Edit Time				

Commissioning

6.4 Installation Menus

Level A	Level B	Level C	Level D	Level E	Level F	Level G	Level H
	RS-232 Setup	Baud Rate	Enter From List				
		Parity	Enter From List				
		Data Bits	7/8				
		Line Feed	Yes/No				
		Network ID	Numeric Entry				
		RTS Key Time	Enter From List				
	Backlight	Enter From List					
	System Info	Version	View Only				
		Battery Capacity	View Only				
		Reset Data/ Time	View Only	mm.dd.yy.h h.mm.ss			
		Op System P/N	View only				
		Checksum	View Only				
		Code	View only				
		System Time	View Only	mm.dd.yy.h h.mm.ss			
Language	Enter From List						

Functions

7.1 Selecting Flow Units

Selecting Flow Units

The [Flow/Total Units] menu is available after selecting a meter type and measurement channel. Use the [Flow/Total Units] menu to select energy and volumetric flow units and an associated time base for the flow rate and total outputs. After making your selections, a view-only menu cell shows the resultant scaling. Another menu cell lets you adjust the output resolution by selecting a display range.

Selecting Flow/Total Units

The [Flow/Total Units] option list allows you to select the rate units the flow meter uses to report energy or volumetric flow. The energy unit default is [E Rate Units]. The default in English units for liquid is [Gallons].

To select energy units:

1. Press the <MENU> key and [Meter Type] will be highlighted.
2. Press the <Right Arrow> to [Dual Path Flow] and then press <ENTER>.
3. The [Dual Path Flow] menu will appear with [Chan/Path Setup] menu item highlighted.
4. Scroll down to the [Flow/Total Units] menu and press the <Right Arrow> to select the [Energy Units] menu.

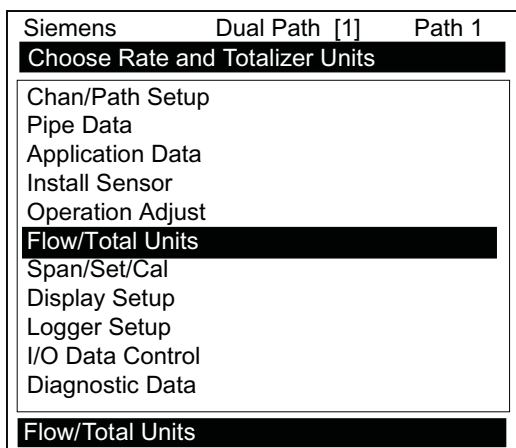

7.1 Selecting Flow Units

5. Press the <Right Arrow> to select [Energy Units].

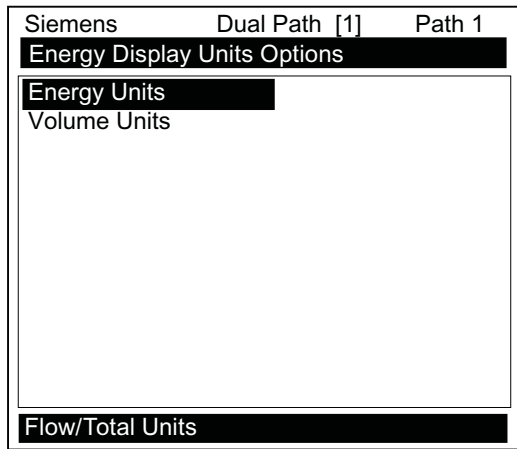

6. Press the <Right Arrow> to select the option list and use the <Up/Down Arrows> to select the desired units.

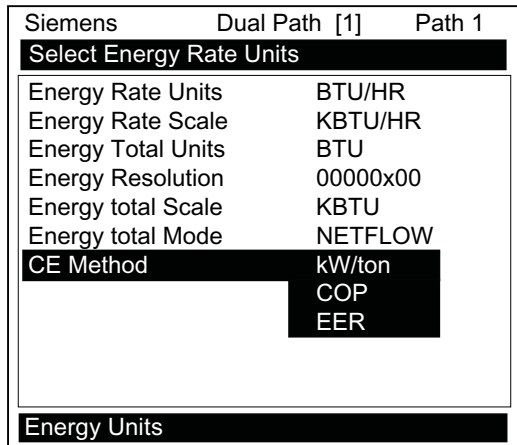

7. Press <ENTER> to store selection.

Totalizer Modes

The Totalizer function operates in any of the modes listed below:

Table 7- 1 Totalizer Modes

Mode	Flow Direction	Notes
POSFLOW	positive flow	Accumulates flow in positive direction only
NEGFLOW	negative flow	Accumulates flow in reverse direction only
NETFLOW	positive or negative flow	Adds to positive total; subtracts from reverse total

Note

NETFLOW (default) is best for applications where there may be zero flow for long periods. It minimizes false Totalizer register increments due to data scatter. Press the <Down Arrow> to accept the default setting.

Selecting Totalizer modes

1. Press the <MENU> key and [Meter Type] will be highlighted.
2. Press the <Right Arrow> to [Dual Path Flow] and then press <ENTER>.
3. The [Dual Path Flow] menu will appear with [Chan/Path Setup] menu item highlighted.
4. Scroll down to the [Totalizer Mode] menu and press the <Right Arrow> to select the Totalizer Mode option list.

Siemens	Dual Path [1]	Path 1
Choose positive, negative or net total		
Flow Vol. Units		Gallons (US)
Flow Time Units		MIN
Flow Disp. Range		Autorange
Flow Disp. Scale		GAL/MIN
Total Vol. Units		Gallons (US)
Totalizer Scale		KGAL
Total Resolution		NEGFLOW
Totalizer Mode		>NETFLOW
Batch/Sample Tot		POSFLOW
Flow/Total Units		

5. Press the <Up/Down Arrows> to select the desired mode.
6. Press <ENTER> to store selection.

Totalizer Mode Controls

From the RS-232 serial port all of the Totalizer commands listed below can be executed using PC keyboard function keys via VT100 terminal key emulation.

Note

Si-Ware or HyperTerminal should be in the Data Display mode when invoking the function keys referenced in the table below. Use the key sequence <Ctrl L> to display the Data Display mode.

Communications Setup

Connect the flow meter to your PC. Refer to Appendix A for communications setup procedures, if needed.

1. Access Si-Ware or, if using a PC, access HyperTerminal from the PC [Programs] menu, then select [HyperTerminal].
2. In [Connection Description] dialog box, enter a connection name (e.g. FUE1010). Click [OK].
3. In [Phone Number] dialog box, select [Direct to COM 1 (or COM 2)]. Click [OK] to select.
4. In [Properties] dialog box, enter RS-232 parameters. Click [OK].
5. At terminal screen, click [File]. Select [Properties].
6. Select [Settings] tab. At [Emulation] box, select [VT-100].
7. Select [ASCII Setup]. In [ASCII Sending] uncheck boxes. In [ASCII Receiving] check [Append line feeds to incoming line ends.]. Click [OK].
8. At the Terminal screen, press <ENTER> and the Data Display mode appears.
9. If not, to enter the Data Display mode type MENU and then press <Ctrl L>.

Table 7- 2 Totalizer Controls (the "n" in <Fn> = channel number)*

Key	PC #	Command	Description
F1 F2 F3 F4	1	CLRTOT (also clears overflow)	Resetting the Totalizer registers clears all total data accumulated during operation. Note: In Dual Path mode, the Totalizer operates only on the virtual system channel (Ch 3). Therefore in this case, the CLRTOT trigger would be <F3> <1>. Commands that can be invoked from Si-Ware or HyperTerminal: Terminal Command: CLRTOT 1.
F1 F2 F3 F4	2	NOTOT (Totalizer Freeze)	Invoking the NOTOT command disables the Totalizer. Totalization will not resume until you repeat the <Fn> <2> key sequence. When you activate NOTOT, an N precedes the TOTAL symbol (i.e. [NTOTAL]) on the LCD Screen. Commands that can be invoked from Si-Ware or HyperTerminal: Terminal Command: NOTOT 1 = Stop Totalizer Terminal Command: NOTOT 1 = Start Totalizer
F1 F2 F3 F4	3	LAPTOT (Totalizer snapshot)	The LAPTOT command freezes the Totalizer screen display. However, the flow meter will continue to update its internal registers. The flow meter will show the current total when you repeat the <F1>< 3> key sequence. When you activate LAPTOT, an L precedes the TOTAL symbol (i.e., [LTOTAL]) on the HyperTerminal screen.
F1 F2 F3 F4	4	CLEAR (Batch/Tot register)	Clears the Batch/Sample Totalizer register. The flow meter maintains a separate Totalizer register for Batching or Sampling applications but cannot be accessed directly. It is used for relay control only. If you assign the system relay to this function, a momentary (200 ms) relay pulse occurs whenever the BATCHTOT register accumulates a specified liquid quantity. In the [Batch/Sample Tot] menu cell the required total flow volume is entered to activate the relay,. This numeric entry must reflect the selected flow total units. The [Totalizer Scale] menu cell shows the applicable flow total units. The sign of the Batch/Sample Total determines positive or negative accumulation.
F1 F2 F3 F4	5	CLEAR (Makeup Latch)	Clears the Makeup Latch. Refer to the Span Data menu [Set Alarm Levels] and then the [Makeup Latch] On / Off option.

*Use the <F1> key as the "Lead-in command" for 4-Path Totalizer operations.

7.2 Span Data

The [Span Data] menu allows you to set 0% and 100% output limits for energy rate (Ve), volumetric flow (Vfo), absolute flow (Vfab) and sonic velocity (Vs). Each menu cell shows appropriate rate units and time base. If you change flow rate units after spanning the system, the computer automatically updates the output data setup to reflect the change. Span limits apply to both the analog outputs and the on-screen stripchart. The flow outputs operate as follows:

<p>Ve <i>Spanned energy rate:</i></p>	<p>The entries establish the Ve span. The Max Energy Flow menu cell sets 100% of span while the Min Energy Flow menu cell sets 0% of span. Use signed numbers for bi-directional spanning. Note that negative (reverse) energy is always lower than positive energy, whatever its absolute magnitude. For example, for a flow measurement range of -30 KBTU to +10 KBTU, the 4mA span will be -30 KBTU, and the 20mA span will be +10 KBTU.</p>
<p>Ts, Tr, Td <i>Spanned Supply, Return Delta Temperature:</i></p>	<p>Use these menu cells to span the two temperatures, Ts and Tr and the computed temperature difference, Td. Use signed numbers for bidirectional spanning.</p>
<p>Vfo <i>Spanned Volumetric Flowrate:</i></p>	<p>The minimum and maximum flow rate entries establish the Vfo span. The Max Flow menu cell sets 100% of span. The Min Flow menu cell sets 0% of span. Use signed numbers for bi-directional spanning. Note that negative (reverse) flow always is lower than positive flow, whatever its absolute magnitude. For example, for a flow measurement range of -30 GPM to +10 GPM, the 4mA span will be -30 GPM, and the 20mA span will be +10 GPM.</p>
<p>Vfab <i>Spanned Absolute Volumetric Flow Rate:</i></p>	<p>Vfab is the absolute magnitude of the volumetric flow rate (Vfo). There are no menu cells provided to span this output. Vfab shares the Vfo span entries. The Vfab minimum span is always zero. The maximum span for Vfab is the largest absolute value of either the min. or the max. flow rate (Vfo) entries. For example, a span between +10 GPM and -30 GPM, spans the Vfab output from 0 GPM to 30 GPM.</p>
<p>Vs <i>Spanned liquid sonic Velocity:</i></p>	<p>Vs is the sonic velocity in meters-per-second (m/s) of the flowing liquid. The min. and max. Vs entries establish the Vs span. Max Vs (m/s) defines 100% of span. The Min Vs (m/s) defines 0% of span.</p>

Maximum span values represent:	Minimum span values represent:
100% of span Current output of 20mA Voltage output of 10 VDC Pulse output of 5000 Hz	0% of span Current output of 4mA Voltage output of 0 VDC Pulse output of 0 Hz

To change the default Span Data settings:

1. At [Meter Type], press <Right Arrow> to [Dual Path Flow] and press <ENTER>.
2. At [Chan/Path] press <Right Arrow> to <Clamp-on> and press <ENTER>.
3. At [Clamp-on] menu scroll down to [Span/Set/Cal] and press <Right Arrow>.
4. Highlight [Span Data] and press the <Right Arrow>.

Siemens	Dual Path	ABC
Span 0% and 100% Values for Analog Data		
Span Data		
Set Alarm Levels		
Calibrate Flowrate	Intrinsic	
Calib. Table 1		
Calib. Table 2		
Calib. Table 3		
Span/Set/Cal		

5. Highlight [Max Energy Flow] and press <Right Arrow> to. Input 100% flow rate numeric data for 20mA. Press <ENTER> to store data.
6. Scroll down to [Min Energy Flow]. Press <Right Arrow> to input 0% flow rate numeric data for 4mA. Press <ENTER> to store data.

Siemens	Dual Path	ABC
Set 100% (20 mA) energy rate		
Max Energy Flow	=0.00	①
Min Energy Flow	0.00	
Max Flow	1848	
Min Flow	1000	
Max Ts	50.0	
Min Ts	25.0	
Max Tr	60.0	
Min Tr	40.0	
Max Td	50.0	
Max Vs MS	2000	
Min Vs MS	1000	
Span Data		

① Input numeric energy flow data here

7.3 Logger Control

Logger Control Menu

The Logger Control menu in the [Meter Facilities] menu provides the Logger controls for the flow meter measurement channels and paths. It allows the user to select data items/alarm events, a logging interval and a destination for Logger reports. While the Logger Setup menu is measurement channel/path specific, this Logger Control menu provides global control functions. This means that the settings made here apply to all measurement channels/paths, meter types, operating modes, etc. This is possible because the flow meter stores logged data in a single file.

The [Est LogTime Left] menu view-only menu cell shows an estimate of the hours and minutes of logging time remaining. For convenience sake, the Display Logger command is essentially a duplicate of the menu cell in Logger Setup. It sends Logger data to the graphic screen with or without line wrapping. The Output Logger command sends data to an external device via the RS-232 serial port. The Clear Logger command erases the entire Logger file.

1. From the Meter Facilities menu access the [Logger Control] menu by pressing the <Right Arrow>.
2. Scroll down to [Logger Control]. Press the <Right Arrow> to access the [Logger Control] menu option list.

Siemens	Dual Path [1]	Path 1
Datalogger Control		
Preferred Units	English	
Table Setups		
Logger Control		
Memory Control		
Analog Out Trim		
RTD Calibrate		
Clock Set	06.23.09	12.46.56
RS-232 Setup	38400 Odd [0]	
Backlight	On	
System Info		
Meter Facilities		

Table 7- 3 Logger Control Menu Option List

Logger Control	Display Logger	Off Line Wrap No Line Wrap
	Output Logger	No Yes
	Circular Memory (Available for Multi-Path units only)	No Yes
	Est LogTime Left	--:--
	Clear Logger	No Yes

Display Logger

This menu cell allows you to send the Logger contents to the display screen. This command is effective only after a successful install. You can set the report to scroll on the screen with or without line-wrap. Selecting line wrap, forces a line feed after approximately 40 characters. In addition, you have to enable datalogging and then select items in the Logger Setup menu. Note that this command transmits the data from both channels/paths.

To send Logger contents to the display screen:

1. Press <Right Arrow> to access the [Display Logger] option list.

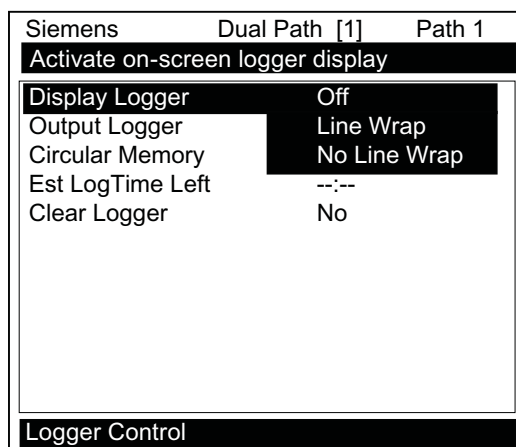

2. Scroll cursor to either [Line Wrap] or [No Line Wrap] by pressing <Up/Down Arrow>.
3. To view Logger contents press <ENTER>.
4. To return to [Logger Control] press <MENU>.

Output Logger

This menu cell allows you to send the Logger contents to an external device (usually a computer or printer) via the flow meter's RS-232 Serial I/O port. This command is effective only after a successful install. In addition, you have to enable datalogging and select data items in the [Logger Setup] menu.

The flow meter interfaces with most serial printers or personal computers for Logger printouts. You must use the proper cabling between the flow meter and the external device. In addition, you must configure the RS-232 Setup correctly. You should turn off the Logger function before you transmit an extensive printout. This will avoid contaminating the printout with new Logger data. Logger reports are sequential ASCII text files.

To send Logger contents to the RS-232 Serial Port:

1. Check the flow meter-to-external device connections and your RS-232 Setup parameters (see RS-232 Setup menu).
2. To access the [Output Logger] option list press <Right Arrow>.
3. Scroll the cursor to [Yes] by pressing <Up/Down Arrow>.

4. To transmit Logger contents to external device via the serial port press <ENTER>.
5. To stop printout press <Left Arrow>.

Circular Memory

In its default mode, the Logger collects data until its memory becomes full. At that time the flow meter suspends datalogging and cannot resume until the Logger memory is cleared (see Clear Logger command). Circular Memory allows the Logger to "write over" its oldest records when memory reaches full capacity. If you enable [Circular Memory], you are assured of always collecting the most recent data. But also remember that you will lose the oldest Logger reports and that further invoking of [Circular Memory] deletes the current contents of the Logger.

To setup and enable Circular Memory:

1. The Logger Mode menu must have the [Memory] menu cell selected.
2. Logger items must be selected (e.g., Site ID, Date, Time, etc.).
3. All active channels/paths in the Channel Setup menu must be disabled. To disable active channels, select the [Channel Enable] menu cell and then [No].
4. In the Logger Control menu, select [Circular Memory].
5. Press <Right Arrow> to access the [Circular Memory] option list.
6. Move the cursor to [Yes] by pressing <Up/Down Arrow>.
7. To store selection press <ENTER>.
8. Lastly, re-enable the channels/paths that you disabled earlier to begin logging.

Est LogTime Left

Est LogTime Left is a "view-only" menu cell that shows an estimate of the amount of Logger time remaining in hours and minutes. This menu cell becomes active after you enable datalogging. Selecting [Circular Memory] and/or event-based datalogging (see Logger Setup), blanks the [Est LogTime Left] field and is based on the log interval and data selections made in the Logger Setup.

Clear Logger

If you use the Logger in its default mode, eventually you will use all the memory available for Logger storage. When this occurs, you will not be able to log more data until you free up the memory. The [Clear Logger] command erases ALL stored Logger data. Therefore, you should evaluate the currently stored data, and print any valuable information before using this command.

Note

Saved Sites also consume Logger RAM.

Clearing Logger Memory

1. To access the [Clear Logger] option list press <Right Arrow>.
2. Move the cursor to [Yes] by pressing <Up/Down Arrow>.
3. To clear the memory press <ENTER>.

7.4 Operation Adjust Menu Settings

Introduction

The Operation Adjust menu becomes available after picking a meter type and measurement channel. It is recommended that you use it after the sensors are installed and operating to "fine-tune" the meter's output characteristics.

Each application presents different data display and output requirements due to unique pipe and liquid conditions. Use the [Operation Adjust] menu to match flow meter operation to the site. You can set damping controls for the primary flow rate output. You can define a Deadband, (usually a very low flow rate), below which the flow output will be forced to zero. You can also select the flow meter response to a continuous Fault condition.

Damping Control

The flow meter provides two different data output filter types, Time Average and SmartSlew. Time Average (recommended) integrates the instantaneous flow rate over a selectable time period. Use the Time Average function when stability in flow reading is essential. A value entered (in seconds) sets the time it takes the flow meter to respond to a rate change. The default is 10 seconds. Enter any amount of time up to 60 seconds maximum.

SmartSlew performs data scatter damping during steady flow periods while maintaining the ability to respond to changing flow rates. SmartSlew values range from [1 to 9]. Pick a higher number to slow flow meter response to a rate change.

Setting the Time Average (default):

1. From the [Dual Path Flow] menu scroll to the [Operation Adjust] menu and press <Right Arrow>.
2. At the [Damping Control] menu press the <Right Arrow> and move the cursor down to [Time Average].
3. To enable Time Average entry press <Right Arrow>.

Siemens	Dual Path [1]	Path 1
Select SmartSlew or TimeAvg Damp		
Damping Control	Time Average	
Energy Deadband	0.00	
Deadband Control	0.00	
Memory/Fault Set	Memory	
Memory Delay <s>	120	
Operation Adjust		

4. Use the numeric keys to type the new Time Average setting.
5. To register the new value press <ENTER>.

Setting SmartSlew :

1. From the [Dual Path Flow] menu scroll to the [Operation Adjust] menu and press <Right Arrow>.
2. At the [Damping Control] menu press the <Right Arrow> and move the cursor down to [SmartSlew].
3. To access SmartSlew option list press <Right Arrow>.
4. Scroll the numeric list to the desired choice by pressing <Up/Down Arrow>.
5. To register the new value press <ENTER>.

Deadband Controls

The meter has two separate and independent deadband controls. One deadband control is for energy flow rate and the other is for volume flow rate. Follow the instructions below to set each deadband control as desired.

Use the Deadband Control to instruct the flow meter to report zero flow if the flow rate falls below a specified level (usually a very low rate). It will prevent the possibility of data scatter (a natural result of digital computation) from causing false Totalizer accumulation during long non-flowing periods. Inspect the actual data scatter during zero flow conditions to find the proper Deadband setting for your application.

Note

The units of the numerical entry (e.g. kGal, BTU/HR, etc.) are the same as the Display Units for each item of energy flow or volume flow.

Note that each deadband setting is independent of the other. For example, if the Volume flow rate falls below the deadband setting for the volume flow, the Volume flow rate will be reported as zero. However, if the Energy flow rate remains above the deadband setting for the energy flow rate, the system will continue to report the measured energy rate (i.e. it will not be zero.).

To edit Deadband default setting (0.000):

1. From the [Dual Path Flow] menu scroll to the [Operation Adjust] menu and press <Right Arrow>.
2. Scroll to the [Energy Deadband] or [Deadband Control] menu.
3. Press <Right Arrow> to enable numeric entry.
4. Use the numeric keys to type in the desired rate (using selected flow rate units).
5. To register the new value press <ENTER>.

Memory/Fault Set

Certain situations will interrupt data production (e.g., an empty pipe or excessive aeration). Use Memory/Fault Set to select the flow meter response to such an interruption. The Fault setting (default) will zero the flow rate output and declare an alarm on a flow display screen, Datalogger report and an assigned relay output.

For some applications, occasional temporary Fault conditions may be a normal part of the process and would not require an alarm response. The flow meter offers a Memory operating mode to support such an application. Memory Mode suspends the flow meter Fault response by preventing the flow outputs from dropping to zero for the interval specified in the Memory Delay menu cell. During the Memory duration, the flow meter will maintain the last valid flow reading measured before the onset of the fault condition. The default Memory Delay is 60 seconds. You may select any duration from 3 to 604,800 seconds (one week).

Selecting Memory Mode

1. From the [Dual Path Flow] menu scroll to the [Operation Adjust] menu and press <Right Arrow>.
2. Scroll to the [Memory/Fault Set] and press <Right Arrow> to access option list.
3. Move the cursor down to [Memory] by pressing <Up/Down Arrow>.
4. To make selection press <ENTER>.
5. This moves the highlight to [Memory Delay (s)].

Memory Delay (s)

Selecting [Memory Delay <s>] activates the suppressed [Memory Delay] menu cell. It allows you to specify the number of seconds that the flow meter maintains its last valid flow reading. When the memory delay expires, it triggers the fault alarm response described previously.

Setting Memory Delay

1. To enable numeric entry press <Right Arrow>.
2. Use the number keys to type the delay in seconds.
3. To register the new value press <ENTER>.

Reflexor Zero/Fault Option (Reflexor Mode Only)

Note

The [Zero/Fault set] menu option only appears on the display if the selected channel is the Reflexor mode.

The Reflexor declares a Fault when the receive signal drops below the Doppler detection threshold. To change the Reflexor response to a Zero Flow indication rather than a Fault, select [Zero] in the [Zero/Fault Set] menu option. Note the following:

1. FAULT – When selected the system will declare the Reflexor channel to be in Fault and the flow meter will indicate "F" on the display screen. Note that when a new Reflexor channel is created the [Fault] option is the default mode. Also note that the sum (or difference) channel will also be declared to be in Fault.
2. ZERO – When selected the Reflexor channel will be declared to be at Zero Flow instead of in Fault and the flow meter will indicate 0.00 on the display screen.

7.5 Setting Relays

Relay Functions

Use the [Relay Setup] menu to assign a function to channel relays. The flow meter supports two types of relay outputs, Alarm Relay and Pulse Relay. Alarm Relay outputs operate in "fail-safe" mode. The relay(s) are energized under normal conditions - an alarm condition causes the relay(s) to de-energize until the alarm clears. The Pulse Relay output supports Totalizer and batch relay functions, with an output pulse width of approximately 200 ms; maximum activation rate is 2.5 pulses per sec. If Totalizer pulses exceed this rate, excess pulses are stored in an overflow register. This allows the relay to "catch up" when flow decreases enough.

Note

Using the <F1> key (Totalizer clear command) also clears all channel Totalizers plus the overflow register described in the last paragraph.

Relay 1 and 2 Function Assignments

The flow meter, depending upon the model, provides at least two alarm relays. Please refer to the Appendix for wiring details. Relays respond to any of the alarm conditions or data functions included on the Relay Option List.

Table 7- 4 Relay Option List

Not Used	Not Active
Power Off	Power Off alarm occurs when power fails.
High Flow	Flow rate exceeds high flow setpoint.
Low Low	Flow rate exceeds or falls below flow setpoint.
Flow Alarm	Flow rate exceeds or falls below flow set points.
Fault Alarm	System loses receive signal (all paths in fault).
Soft Fault	Fault condition - memory mode active.
Spacing	Sensor spacing needs adjusting.
Empty	Empty pipe alarm.
Aeration	Aeration percentage exceeds alarm set point.
Reverse Flow	Flow is in negative direction.
BatchTot	Batch/Sample total advances.
Pos Total	Positive total volume advances 1 digit.
Neg Total	Negative total volume advances 1 digit.
High Energy	High Energy value relay setpoint.
Low Energy	Low Energy value relay setpoint.
Energy Postot	Positive energy totalizer advances by 1 digit.
Energy Negtot	Negative energy totalizer advances by 1 digit.
Td	Temperature diference relay setpoint.
Ts	Supply temperature relay setpoint.
High CE	High Chiller Effeciency value relay setpoint.
Low CE	Low Chiller Effeciency value relay setpoint.

Assigning functions to Relay 1:

1. From the [Dual Path Flow] menu scroll down and highlight [I/O Data Control].
2. Press <Right Arrow> and scroll down to [Relay Setup].

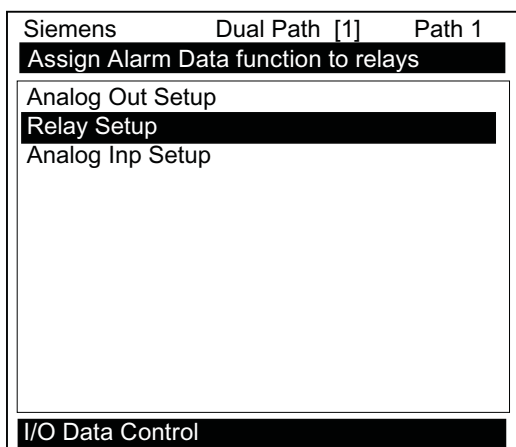

3. To access the [Relay Setup] option list press <Right Arrow>.

4. Move the cursor to the desired Relay assignment by pressing <Up/Down Arrow>.

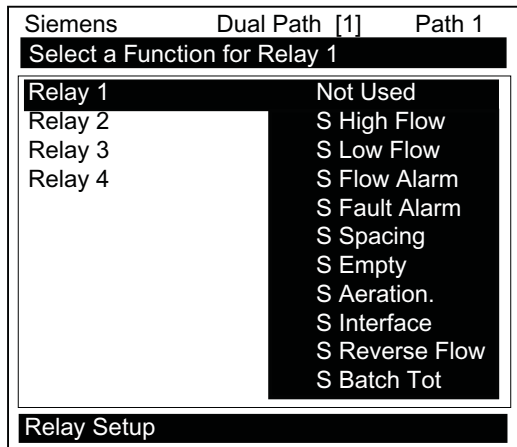

5. To store selection press <ENTER>. Repeat procedure for all other relays.

7.6 Memory Control

Introduction

Memory Control is a reference menu that shows the amount of bytes of data memory left. The data memory capacity depends on the number and complexity of the site setups stored in memory and the size of the current Datalogger file.

The [Memory Control] menu is located in the [Meter Facilities] menu.

Table 7- 5 Memory Control Menu

Log Memory Left→	XXXXXXX
Memory Map→	No Yes
Defragment→	No Yes

Log Memory Left

This view only menu cell shows the minimum remaining number of characters available for Datalogger and site storage. When the Datalogger is enabled for circular mode, the meter allocates all memory left except for two conventional empty sites required for Datalogger use.

To view the amount of data memory bytes available press <Right Arrow>.

Memory Map

Selecting [YES] for this item enables a snapshot display of current memory usage. In this display, the asterisk indicates a used memory block, a space indicates a free block, while a dash character indicates unused filler.

Defragment

Selecting [YES] for this item consolidates memory data blocks into contiguous storage; collapsing the filler regions. You may be able to use an additional block for site or Datalogger storage as a result. Use this command if you seem to be out of memory even though the [Log Memory Left] item indicates free capacity.

7.7 Analog Out Setup

The flow meter provides current, voltage and pulse-rate analog outputs. The [Analog Out Setup] menu allows you to assign data functions for these signals. The transmitter terminal strip contains the analog output terminals.

Table 7- 6 Analog Outputs

Io (Isolated Current)	4 to 20mA varies in proportion to an assigned data function.
Vo (DC Voltage)	0 to 10 VDC varies in proportion to an assigned data function.
Pgen (TTL Logic)	0 to 5000 Hz varies in proportion to an assigned data function.

Table 7- 7 Analog Out Setup Data Categories

Vfo	Spanned volumetric/mass flow.
Vfo2	Additional Spanned volumetric/mass flow.
Vf	Spanned unsigned flow magnitude.
Vs	Spanned liquid sonic velocity.
Valc	Receive signal amplitude.
Vaer	Relative degree of liquid aeration/cavitaion.
Ve	Spanned instantaneous energy rate.
Ts	Spanned supply temperature.
Tr	Spanned return temperature.
Td	Spanned temperature difference (delta).
CE	Spanned Chiller efficiency rate.

Io Output Functions

This output also provides an industry-standard fault indication by dropping to 2mA if assigned to flow rate and under fault conditions.

Assigning a function to the current output:

1. From the [Chan/Path Setup] menu scroll to [I/O Data Control].
2. Press <Right Arrow> to highlight the [Analog Out Setup] menu.

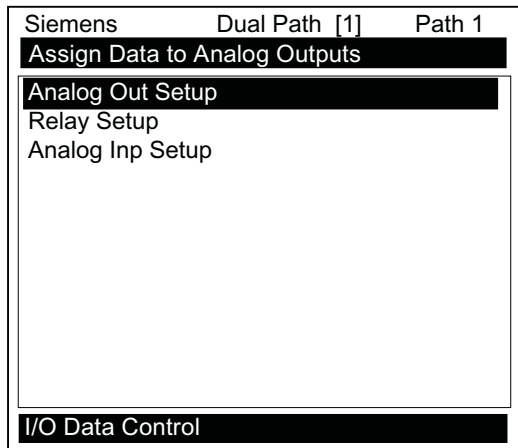

3. Press <Right Arrow> twice to access the [Io] option list.
4. Move the cursor to the desired data function by pressing <Up/Down Arrow>.

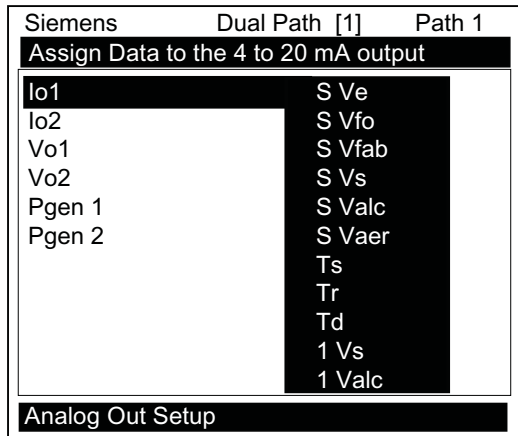

5. To store selection press <ENTER>.

Vo Output Functions

The Vo analog output is a 0-10 VDC signal that varies linearly in relation to a selected function.

Assigning a function to the voltage output:

1. From the [Analog Out Setup] menu, press <Right Arrow> to access the [Vo1] option list.
2. Move the cursor to the desired data function by pressing <Up/Down Arrow>.
3. To store selection press <ENTER>.

Note

Refer to drawing 1010N-7-7 for Analog output connections.

Pgen Output Functions

The Pgen analog output is a buffered TTL-compliant pulse rate signal that varies linearly from 0-5000 Hz in relation to a selected data function.

Assigning a function to the Pgen output:

1. From the [Analog Out Setup] menu, press <Right Arrow> to access the [Pgen] option list.
2. Move the cursor to the desired data function by pressing <Up/Down Arrow>.
3. To store selection press <ENTER>.

7.8 Analog Input Setup

Analog Input Setup

Note

Some versions of the FUE1010 energy portable flow meter have the ability to read analog input signals. The [Analog Inp Setup] menu cell is not displayed if the operating system of your model does not include this facility.

The optional Analog Input Setup function assigns an active analog input to a measurement channel/path. The flow meter provides two DC current input ports for Dual Channel/Dual Path units. These ports can be assigned to represent supply temperature, return temperature or power consumption (see table below). The DC current input ranges from a zero level of 4mA to a full scale of 20mA. The [Analog Inp Setup] menu cell allows you to enable this port and then span it to any desired scaling (see table below).

Note

Refer to the Installation Drawings or I/O Module markings for the locations of these inputs and wiring procedures.

I/O Data Control	Analog Inp Setup	lin1	Input	Off Aux Ts Deg F TsDeg C Tt Deg F Tr Deg C PckW (used with CE Method only)
				4 mA Numeric entry 20 mA Numeric entry
		lin2	Input	Same as lin1

Note

Two DC current input ports for Dual Channel/Dual Path unit.

One DC current input port for Dual Channel units.

The flow meter recognizes the first analog input variable that is assigned to any given parameter and ignores any subsequent input with the same assignment. For example, if lin1 and lin2 are both assigned to represent Supply Temperature (Ts Deg F) the flow meter will only use the Supply temperature input from lin1.

Setting the Analog Current Input

The DC current input port must be enabled first. From the [Analog Inp Setup] menu proceed as follows:

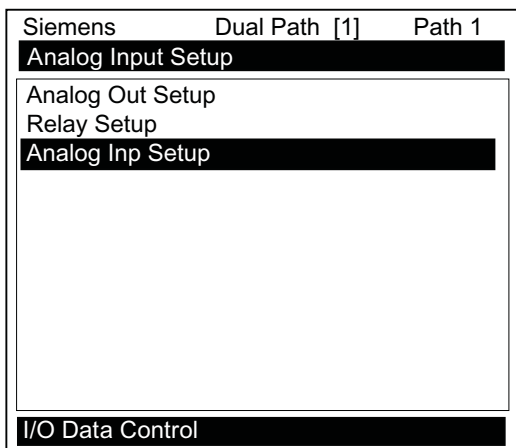

1. Access the [lin1] option list by pressing the <Right Arrow> twice.

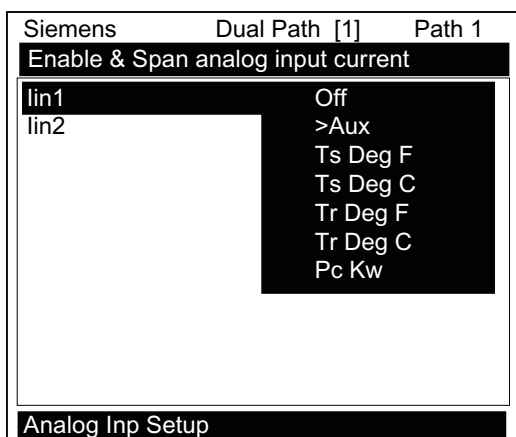

2. Move the cursor down to [Aux] by pressing the <Down Arrow> and then press <ENTER>. This enables the port to receive an input current. The cursor moves to [4 mA].

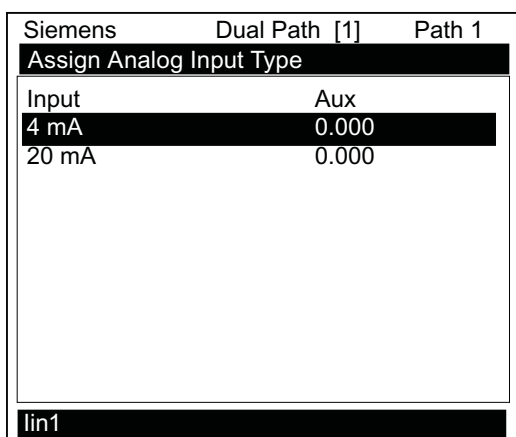

3. To enable numeric entry, press the <Right Arrow>. Type a numeric value corresponding to a 4mA input signal.
4. To store the data press <ENTER>. This moves the cursor to [20 mA].
5. To enable numeric entry, press the <Right Arrow>. Type the numeric value corresponding to a 20mA input signal.
6. To store the data, press <ENTER>.

[PckW] Menu Cell

The [PckW] menu cell represents power consumption in kilowatts. When assigned to an analog input this parameter will be used to compute chiller or heating efficiency.

CE Method

Note

Refer to www.EngineeringToolbox.com (www.EngineeringToolbox.com).

The FUE1010 ultrasonic energy flow meters can be configured to provide an Energy Efficiency output. Modifications were implemented using the standard FUE1010 analog input spanning methods in an effort to simplify operator monitoring of air conditioning efficiency data. These changes allow the flow meter to calculate chiller efficiency. The flow meter calculates chiller or heating efficiency through use of an available analog input, which can be assigned to represent power consumption (kW).

KW/ton

Cooling Load in kW/ton - Commonly used for large commercial and industrial air-conditioning, heat pump and refrigeration systems. KW/ton is defined as the ratio of the rate of energy consumption in kW to the rate of heat removal in tons at the rated condition. The lower the kW/ton the more efficient the system.

$$\text{kW/ton} = P_c / E_r$$

where: P_c = energy consumption (kW)

E_r = heat removed (ton)

COP

Coefficient of Performance - COP is the basic unit less the parameter used to report the efficiency of refrigerant based systems. COP is the ratio between useful energy acquired and energy applied.

$$\text{COP} = E_u / E_a$$

Where: E_u = useful energy acquired

E_a = energy applied.

COP can be used to define cooling efficiency or heating efficiency as with a heat pump.

- For cooling, COP is defined as the ratio of rate of heat removal to the rate of energy input to the compressor.
- For heating, COP is defined as the ratio of the rate of heat delivered to the rate of energy input to the compressor.

COP can be used to define the efficiency at a single standard or non-standard condition or a weighted average seasonal condition. The term may or may not include the energy consumption or auxiliary systems such as indoor or outdoor fans, chilled water pumps, or cooling tower systems. For purposes of comparison the higher the COP the more efficient the system.

COP can be treated as an efficiency where COP of 2.00 = 200% efficient. For unitary heat pumps, ratings at two standard outdoor temperatures of 47°F and 17°F (8.3°C and -8.3°C) are typically used.

EER

Energy Efficiency Ratio - EER is used to define the cooling efficiency of unitary air conditioning and heat pump systems.

The efficiency is determined at a single rated condition specified by the appropriate equipment standard and is defined as the ratio of net cooling capacity (or heat removed in Btu/h) - to the total input rate of electric energy applied (in watt hours). The units of EER are Btu/w.h.

$$EER = E_c / P_a$$

Where: EER = energy efficient ratio (Btu/w.h)

E_c = net cooling capacity (Btu/h)

P_a = applied energy (w.h)

7.9 Energy AnCal

The [Energy AnCal] menu cell allows you to enter an artificial energy rate in current rate units that will drive the flow meter analog outputs, energy totalizer output and the display screen shown below. You can use AnCal to check the analog outputs or as a reference source for calibrating external devices such as remote display screens or chart recorders and RTUs. To test the Totalizer function, leave Energy AnCal active long enough for an accumulation to appear on the diagnostic data screen shown below. Moving the cursor from the menu cell cancels the AnCal function.

Siemens	2 Channel [1]	ABC
Energy Rate Simulation Control		
Energy Rate MBTU/H	10.0434	①
Energy Total KBTU	1211.8603	
Ts	75.07 F	
Tr	31.73 F	
Td	43.33 F	
CE kW/ton	1.100	
Energy ANCAL	=10.000	
Energy Data		

- ① The [Energy Rate] menu cell immediately reflects the Energy AnCal entry. Over time the Energy Total will also increase.

To activate Energy AnCal:

1. Move the cursor to the [Energy AnCal] menu cell by pressing <Up/Down Arrow>.
2. Press <Right Arrow> to enable numeric entry. Note that an equal sign (=) appears before number.
3. Type the desired flow rate using current rate units (e.g., 10.00 MBTU/H). Note that the [Flow] menu cell now reflects the artificial rate.
4. Move the cursor away from the menu cell by pressing <Up/Down Arrow> to turn Energy AnCal off.

7.10 Analog Output Trim

Introduction

Analog Out Trim function allows you to fine-tune the flow meter’s analog voltage and current outputs using a multi-meter connected to the output under test. In addition, you can use a frequency counter to fine-tune the flow meter’s pulse rate output.

Note

The current, voltage, and Pgen trimming will be limited by the 12-bit resolution of the flow meter’s D/A Converter (DAC).

1. From the [Meter Facilities] menu, scroll to the [Analog OutTrim] menu.
2. Press the <Right Arrow> to access the option list.

Siemens	Dual Path [1]	Path 1
Analog Output Trim		
Preferred Units	English	
Table Setups		
Logger Control		
Memory Control		
Analog Out Trim		
RTD Calibrate		
Clock Set	06.25.09	10.52.49
RS-232 Setup	9600 None 8 [0]	
Backlight	On	
System Info		
Meter Facilities		

Table 7- 8 Analog Out Trim Menu Structure

Analog Out Trim	Trim Io1/Io2	Operate Trim@4mA Indicated mA=x.xx
	Trim Vo1/Vo2	Operate Trim@2V Indicated V=x.xx
	Trim Pgen1 / Pgen2	Operate Trim@1 Hz Indicated Hz=xxxx

Current Output Trim (Io1 & Io2)

Note

Can be trimmed to within .005mA of nominal.

To calculate a current output:

1. Set up an ammeter to read amps, then connect it to the supply and return terminals of the current output under test.
2. Move the highlight to the port to be tested, press <Right Arrow> and then press <Down Arrow> to move the cursor to [Trim @ 4mA].

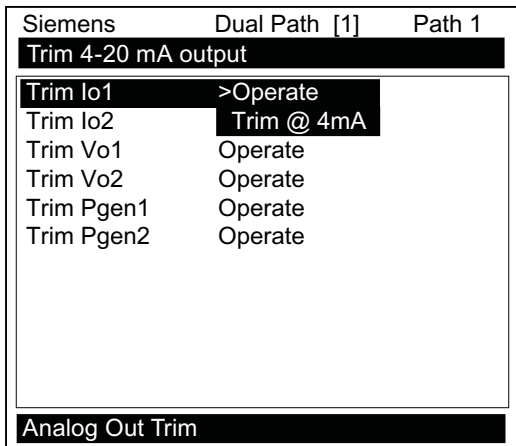

3. Press <ENTER>. This triggers a 4.00 mA pop-up window. The ammeter will now be reading 4.00 mA.
4. If the ammeter reading does not match, use the numeric keys to type in the ammeter reading.
5. Press <ENTER> to register setting. This adjusts the flow meter's DAC (digital-to-analog converter) so that a 4mA output corresponds with 4mA on the ammeter.
6. Re-check the ammeter to make sure that it is now reading 4mA.

Voltage Output Trim (Vo1 & Vo2)

Note

Can be trimmed to within .0025 V of nominal.

To calculate a voltage output:

1. Set up the multi-meter to read volts, then connect it to the supply and return terminals of the voltage output under test.
2. Move the highlight to the port to be tested by pressing <Up/Down Arrow>, press <Right Arrow>, then press <Down Arrow> to move the cursor to [Trim @ 2V].

Siemens	Dual Path [1]	Path 1
Trim 0-10 Volt output		
Trim Io1	Operate	
Trim Io2	Operate	
Trim Vo1	>Operate	
Trim Vo2	Trim @ 2V	
Trim Pgen1	Operate	
Trim Pgen2	Operate	
Analog Out Trim		

3. Press <ENTER>. This triggers a 2.00 Volts pop-up window. The multi-meter will now be reading 2.00 Volts.
4. If the multi-meter reading does not match, use the numeric keys to type in the multi-meter reading.
5. Press <ENTER> to register setting. This adjusts the flow meter's DAC (digital-to-analog converter) so that a 2.00 Volts output corresponds with 2.00 Volts on the multi-meter.
6. Re-check the multi-meter to make sure that it is now reading 2.00 Volts.

Pgen Output Trim

Note

Can be trimmed to within 1.25 Hz of nominal.

To calibrate a pulse rate output

1. Connect a frequency counter to the signal and reference terminals of the pulse rate output under test.
2. Move the highlight to the port to be tested by pressing <Up/Down Arrow>, press <Right Arrow>, then press the <Down Arrow> to move the cursor to Trim @ 1kHz.
3. Press <ENTER>. This triggers a 1 kHz pop-up window. The frequency counter will now be reading 1 kHz.
4. If the frequency counter reading does not match, use the numeric keys to type in the frequency counter reading.
5. Press <ENTER> to register setting. This adjusts the flow meter's DAC (digital-to-analog converter) so that a 1 kHz output corresponds with 1 kHz on the frequency counter.
6. Recheck the frequency counter to make sure that it is now reading 1 kHz.

7.11 RTD Calibration

Resistive Temperature Device (RTD) Calibration

The RTD Calibrate Menu appears on all SITRANS F 1010 models. Use this menu to calibrate Temperature Sensors to an external standard. It is important to note that Siemens RTD temperature sensors are factory-calibrated for high accuracy. We recommend that before deciding to perform the calibration, check the current RTD reading in the [Diagnostics/Liquid Data] menu. You may find that you do not even need to calibrate the sensor. In any case, make sure that the temperature reading stabilizes before proceeding further. The [RTD Calibrate] menu allows you to perform an external calibration, which can be accomplished either by data entry of the current RTD temperature or by a 0°C (32°F) Ice-Bath procedure. You can switch between the intrinsic and external calibration modes at any time.

Note

If you perform an external temperature calibration, you should mark and record the location of each connector and sensor-cable. Once you have re-calibrated the temperature sensors, changing the sensor/connector orientation established during the procedure may void the calibration.

1. From the [Meter Facilities] menu scroll to the [RTD Calibrate] menu.
2. To access the [RTD Calibrate] menu press <Right Arrow>.

Siemens	Dual Path [1]	Path 1
Calibrate Temperature Sensors		
Preferred Units	English	
Table Setups		
Logger Control		
Memory Control		
Analog Out Trim		
RTD Calibrate		
Clock Set	06.25.09	10.52.49
RS-232 Setup	9600 None 8 [0]	
Backlight	On	
System Info		
Meter Facilities		

Table 7- 9 RTD Calibrate Menu Structure

RTD Calibrate	Ch 1 Ts - RTD 1→	Factory / User Cal
	Ch 1 Tr - RTD -2	Factory / User Cal
	Ch 2 Ts - RTD 3→	Factory / User Cal
	Ch 2 Tr - RTD 4→	Factory / User Cal

RTD Calibration by Entry Data

The [RTD Calibrate] menu allows you to adjust the intrinsic RTD reading to match an external reference thermometer by directly entering its reading. Only perform this procedure while the RTD under test is installed and currently measuring temperature.

To enter the current RTD temperature:

1. From the [RTD Calibrate] menu press <Right Arrow> to access the RTD option list.
2. Press <Right Arrow> to highlight the RTD you want to calibrate (RTD 1 or RTD 2).
3. Move the highlight to [Factory] or [User Cal] then press <ENTER>.

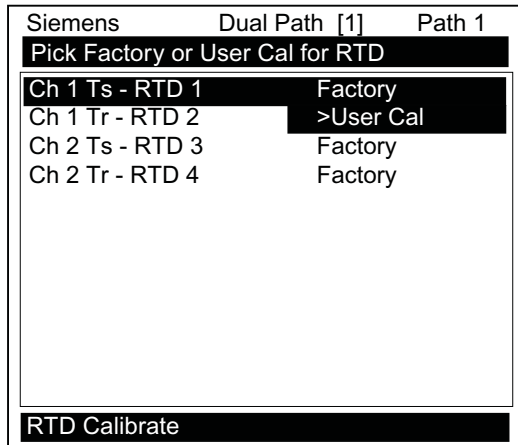

4. This triggers the pop-up window:

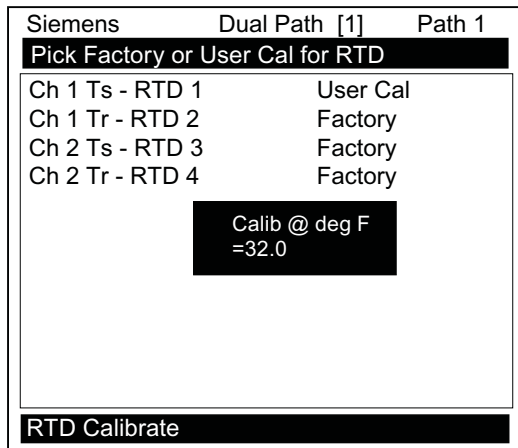

5. To enable numeric entry <Right Arrow>, then type in the reading of the reference thermometer (e.g., 72.0).
6. To recalibrate the RTD sensor <ENTER>. To verify the calibrated reading, go to the Dual Path Flow menu [Diagnostic Data/Liquid Data] menu to check the current RTD output. Make sure that it coincides with the reading of the reference thermometer. Repeat for the other RTD, if necessary.

Note

Factory Calibration provides an additional prompt after a new temperature is entered: [Are you Sure? No Yes]. It is recommended that you use [User Cal] to avoid alteration of preset factory calibration.

Ice Bath RTD Calibration

Use distilled, deionized water and ice mixture at 0°C (32°F) equilibrium for an ice bath. Ensure temperature with a reference thermometer. Siemens can not assume responsibility for the incorrect design, construction or operation of an Ice Bath.

NOTICE

Sensor Damage

If RTD sensor makes direct contact with ice during an ice bath calibration procedure the sensor may be damaged and the calibration results will be incorrect.

Do not allow an RTD sensor to make direct contact with ice during an ice bath calibration procedure.

To perform a 0°C (32°F) calibration:

1. Immerse RTD sensor in deionized water and ice mixture. Stir the mixture constantly.
2. In the [RTD Calibrate] menu move the highlight by pressing the <Up/down Arrow> to the RTD you want to calibrate (RTD 1 or RTD 2).
3. To access the RTD option list press <Right Arrow>. Move the highlight to [User Cal] then press <ENTER>. This triggers the pop-up window.
4. When you are sure that the RTD Sensor is at 0°C (32°F), press <ENTER> to recalibrate the RTD sensor.
5. To verify the calibrated reading, go to Dual Path Flow [Diagnostic Data/Liquid Data] menu to check the current RTD output. Make sure that it coincides with the reading of the reference thermometer. Repeat for the other RTD, if necessary.

7.12 Reflexor

Reflexor is one of the operating modes available on certain SITRANS F 1010 models. The Reflexor operating mode utilizes Doppler flow detection along with digital signal processing techniques to successfully measure flow under conditions that may not be suitable for transit-time flow measurement. The Reflexor samples the flow stream as it detects Doppler shift. It converts the Doppler shift information by use of Fast Fourier Transform (FFT) and filters the FFT to determine the flow rate. The Reflexor mode will operate with many of the same sensors that are used with transit-time flow measurement along with those which are specifically designed for Doppler flow measurement. Use of any other sensor than shown in these instructions may result in failure to measure or give an incorrect flow rate indication.

Typical Installation

The typical steps to complete the Reflexor installation procedure are as follows:

1. Collect the site data (pipe and liquid data, part numbers, etc.).
2. Choose a mounting location for the flow sensors.
3. Prepare the pipe for sensor's mounting.
4. Access the Installation Menu and create a site.
5. Enter the pipe parameters.
6. Mount flow sensors on pipe and connect to flow meter.
7. Invoke the sensor installation procedure.
8. Optimize installation through use of the Spectra Display and diagnostic data.

Almost all menu cells will contain default parameters and will not require any additional action. To obtain operation you will only need to access the menu cells for required parameters, such as pipe data. Obtaining accurate flow rate data will take less than five minutes.

Application conditions may require you to mount the sensors using the adjacent mounting method as described and shown in this section.

Selecting a Sensor Set

Maximum sensitivity will be obtained with use of the 191N1S sensor set.

Alternative sensors recommended for use by Reflexor include:

- 1011 Universal size C1, C2 and C3
- 1011 HP-T1 size B1H and A3H
- 1011 HP-T2 size B1H and A3H
- 1011 HP-T3 size B1H and A3H
- 991 Universal size 2 and 3A High and Very High Temperature versions
- 990 (991 Sensor)

The sensor models are also available for submersible and extended temperature applications.

Selecting Sensor Mounting Location

Select a sensor mounting location that has a fully developed flow profile. Do not locate the sensor so that sonic energy enters a region that is not representative of the flow velocities at the measuring location. Use the figure below as a guide to select the proper mounting location.

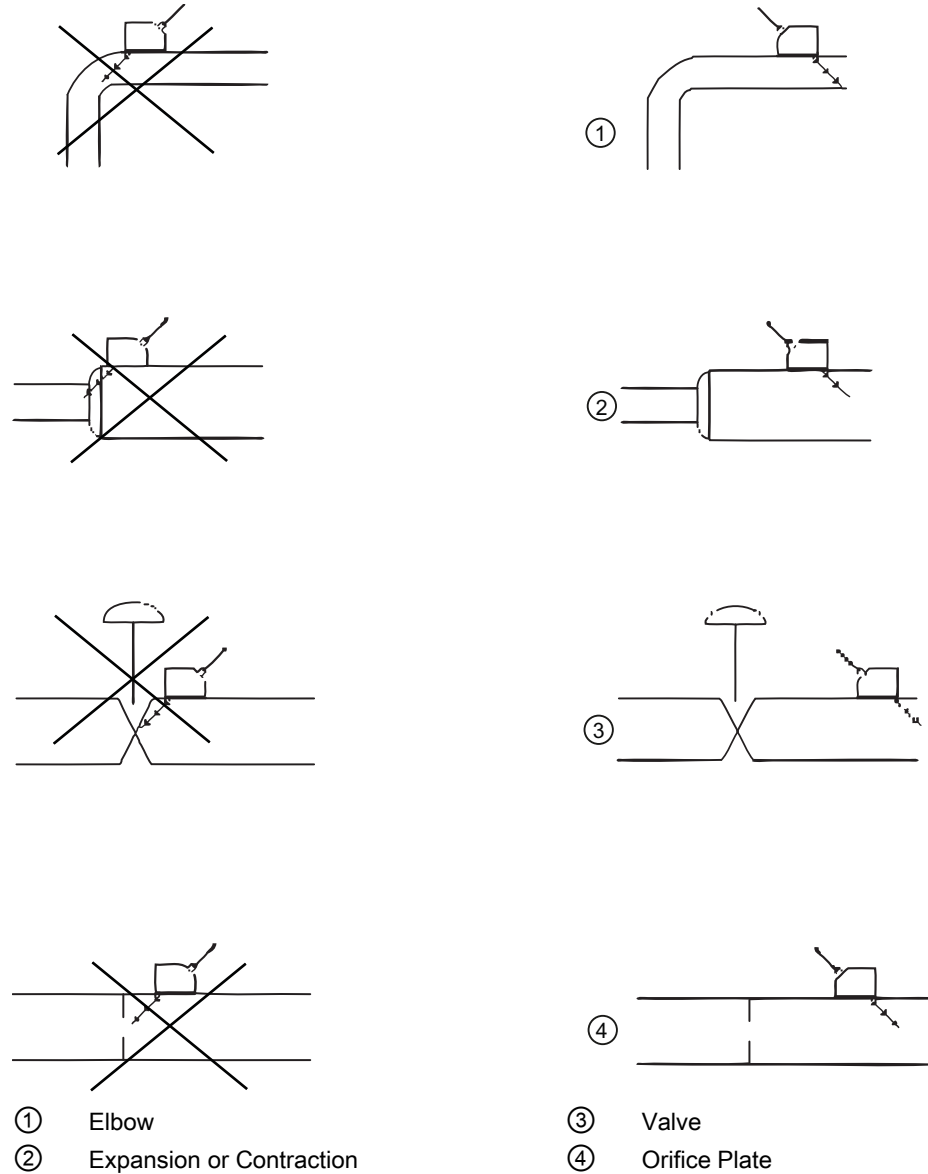

Figure 7-1 Sensor Mounting Examples

Mounting Sensors

Two mounting configurations are available in the Reflexor Mode:

- Adjacent mounting locates the two sensors alongside each other using a single mounting chain or strap.
- In-Line mounting locates the two sensors axially along the pipe using two mounting chains or straps.

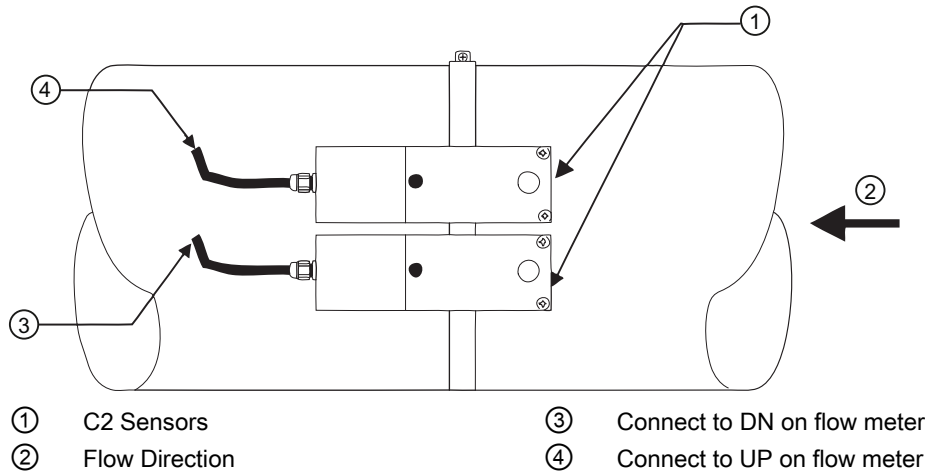

Figure 7-2 Adjacent Sensor Mounting

On inline mounted metal pipes the Receive Sensor is always located downstream of the Transmit Sensor. On plastic pipes the Transmit Sensor is always located downstream of the Receive Sensor.

Table 7- 10 Inline Metal and Plastic Pipe Cable Connections

Sensor	Metal Pipe	Plastic Pipe
C2 Sensor (A)	DN	UP
C2 Sensor (B)	UP	DN

In both cases, the cable entry will be on downstream side. Adjacent mounting will provide the maximum sensitivity to flow. Refer to the appropriate sensor installation drawing for the 191N1S (Installation Drawing 191N1S-7).

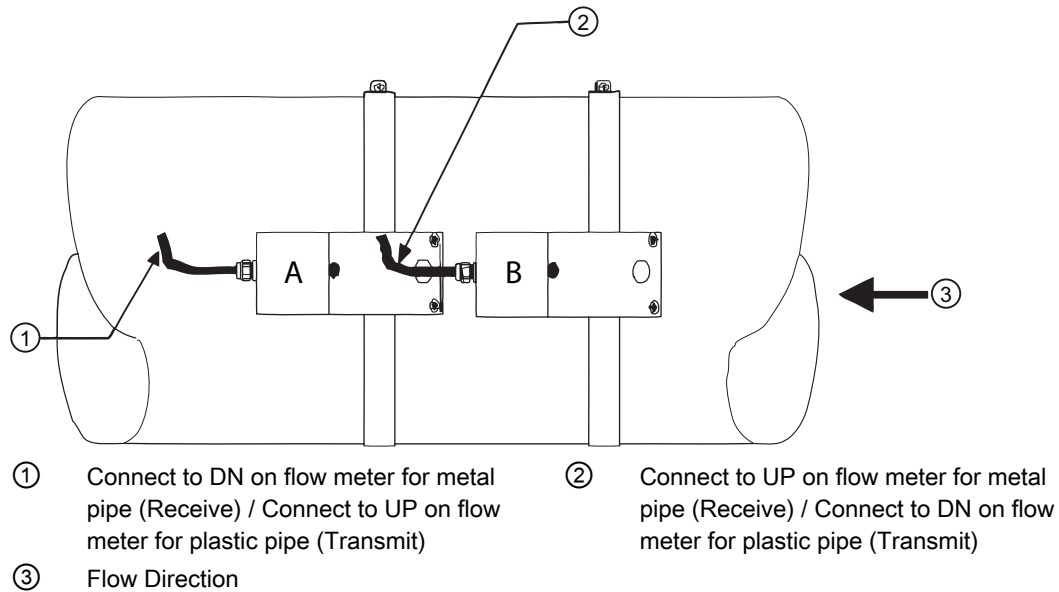

Figure 7-3 In-Line Sensor Mounting

Connecting Sensor Cables

Connect sensor cables between the sensors and the flow meter. The XMIT (transmit) sensor is connected to the Up cable connection and RCV (receive) sensor is connected to the Down cable connection. The UP/DN orientation is important for the in-line sensor configuration. It is not a factor for the adjacent configuration.

Select Reflexor Operating Mode

Select [Meter Type] as [Reflexor] for the channel that is to be used as Reflexor. Dual channel units may have either one or both channels used in the Reflexor mode.

Installing Reflexor Operating Mode

1. From the [Meter Type] menu press the <Right Arrow>, select the desired channel setup and press <ENTER>.
2. Press the <Right Arrow>, scroll to [Reflexor] and press <ENTER>.

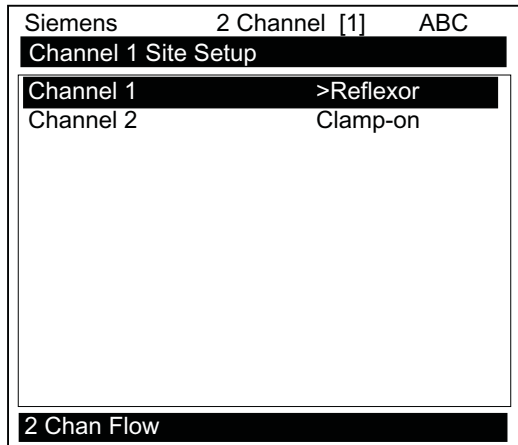

3. At the [Channel Setup] menu press the <Right Arrow>.
4. Scroll down to [Create/Name Site] and create a site or use a previous Saved Site setup by highlighting [Recall Site].

Note

If a previous Saved Site is recalled, and the same sensor and location is used, then no other installation steps are required.

5. Press the <Left Arrow> and scroll to [Pipe Data] and enter the required pipe data.

Sensor Selection

1. From [Pipe Data] scroll to the [Install Sensor] menu and press the <Right Arrow>.
2. At [Sensor Model], press the <Right Arrow> and select the proper group of sensors that match the mounted sensor set. For all 191N, select 190.
3. At [Sensors Size], select the proper size of sensor mounted. For all 191N, select 191.

Note

If the Flow Volume and Time units are not set to the default units of Gallons per Minute, then it is recommended to change those units now by use of the [Flow/Total Units] menu.

4. In the [Install Sensor] menu, scroll down to [Flow Range], press the <Right Arrow> and select the lowest flow range rate available that is at least **two times higher** than the maximum flow expected at this application.
5. At [Install Complete], for new installations, press the <Right Arrow>, select [Install], and then select [Yes]. Press <ENTER>.

Siemens	2 Channel [1]	ABC
Install Completed?		
Sensor Model	1011 Universal	
Sensor Size	C2	
Flow Range GAL/MIN	14.99	
Install Complete	Yes	
Spectra Graph	No	
Install Sensor		

The flow meter is now operational and the display will show flow by pressing the <MENU> key.

The Spectra Graph

The Spectra Graph provides a powerful tool to determine if the installation has achieved an adequate margin of operation. It also eliminates the possible effects of mechanical vibration and external RFI (Radio Frequency Interference). Mechanical vibration and external RFI can cause other types of Doppler flow meters to be inaccurate. The Spectra Graph display provides keypad control keys that allow adjustments of application dependent parameters, if required, while observing the results of these adjustments. Application dependent parameters are the Low and High Limit Cursors and the Noise Cursor. In most cases, only the Noise Cursor will be required to be adjusted.

The reported flow rate is the mean value of the included Spectra Graph bars. It is computed by excluding signals that are lower (to the left of) than the Low Limit Cursor or higher (to the right of) than the High Flow Cursor or lower (under) than the Noise Cursor.

Spectra Graph Cursor Use

Table 7- 11 Cursor Definitions

Cursor	Definitions
High Limit Cursor	This cursor appears as a vertical line on the right side of the Spectra Graph. All signals to the right of this line will be excluded from the flow calculation. Use this adjustment if the right side of the Spectra Graph has noise that is larger in amplitude than the signal that is produced by flow. The cursor may be arbitrarily placed at two times the maximum flow expected.
Low Limit Cursor	This cursor appears as a vertical line on the left side of the Spectra Graph. All signals to the left of this line will be excluded from the flow calculation. Use this adjustment if the left side of the Spectra Graph has noise that is larger in amplitude than the signal that is produced by flow. The cursor may be arbitrarily placed at one half the minimum flow expected.
Noise Level Set Cursor	This cursor appears as a horizontal line on the Spectra Graph. All signals below this line will be excluded from the flow calculation. Position the cursor approximately one quarter the height of the FFT peak.

Using Spectra Graph Data and Controls

When the Spectra Graph is first displayed:

- The data shown on the top highlighted line shows Velocity in feet-per-second (F/S) on the left side.
- The volumetric Flow Rate in the current rate units is displayed on the right side.

You can scroll the data shown by pressing the <Up and Down> Arrows.

1. Pressing the <Up Arrow> changes the data in the highlight to [Diagnostic Data] containing, from left to right: (Hz) Doppler shift frequency in Hertz, (mV) Signal Amplitude in millivolts, (FFT Pk) Peak FFT magnitude and (%D) FFT Percent Deviation. Carefully inspect the data for Signal Amplitude and Percent Deviation. Refer to the "Available Adjustments to Spectra Graph" table and the "Reflexor Diagnostic Data" table in this section for details. Press the <Down Arrow> to return to [Velocity].
2. Press the <Down Arrow> from Flow Velocity in feet per second (F/S) to advance to the Noise Level Set cursor control. A numeric indication of the Noise Level Cursor position is provided in the highlighted area. Refer to the "Available Adjustments To Spectra Graph" table for details.

3. Adjust the Noise Level cursor, if required, by pressing the <+> key to increase or <-> key to decrease.

Note

A delay in response to all keys will occur. This is due to the longer periodic sampling of the keyboard by the processor while performing FFT's.

4. Press the <Down Arrow> from Noise Level to advance to the High Limit cursor control. The <+> and <-> key are active in this position. Refer to the "Available Adjustments To Spectra Graph" table for details.
5. Press the <Down Arrow> from High Limit to advance to the Low Limit cursor control. The <+> and <-> keys are active in this position. Refer to the "Available Adjustments To Spectra Graph" table for details.
6. Press the <Down Arrow> from Low Limit to advance to the Carrier FX control. The <+> and <-> keys are active in this position.
7. Press the <Down Arrow> from Carrier FX to advance to the Diagnostic Data Display. The <+> and <-> keys are active in this position.
8. To exit the Spectra Graph, press the <MENU> key.
9. To display the Digital Flow Display, press the <MENU> key from any Installation Menu location.

Available Spectra Graph Adjustments

Adjustment	Function	Notes
Noise Level Set	Noise Filter	Set to approximately one quarter the Peak FFT value for typical flow conditions.
High Limit	Low Pass Filter Setting	Set to two times the maximum flow rate.
Low Limit	High Pass Filter	Set to one half minimum flow if noise is present. In most cases, leave at zero.
Carrier Fx	Transmit Frequency Code	Adjust only under guidance of technical support staff.

Reflexor Diagnostic Data

The [Diagnostic Data] menu and the [Application Info] sub menu screen provide one location where all diagnostic data can be viewed.

Note

Adjustments can not be made on the [Application Info] menu screen. Adjustments can only be made on the Spectra Graph.

Table 7- 12 Diagnostic Data

Application Information	Function / Explanation
Low Limit	High Pass Filter Setting
High Limit	Low Pass Filter Setting
Noise Level Set	Noise Filter Setting
Doppler Frequency (Hz)	Average FFT Frequency
% Deviation	The width of Spectra is used to determine beam penetration and calibration. The selection of "Slurry" in Application Data is recommended for flow rate indication accuracy when the % Deviation is less than 25. For % Deviation above 35 the use of "Liquid" is recommended. For applications that continuously have % Deviation between 25 and 35 proper selection of either Liquid or Slurry can be confirmed by comparison to a known flow reference.
Signal Peak-to-Peak mV	Peak-to-Peak demodulation signal amplitude. The acceptable range is between 100 and 3200 mV during typical flow conditions. If less than 100 mV, check Sensor type used and mounting configuration. If greater than 3200 mV, try in-line mounting and/or "detune" Carrier Fx.
FFT s/sec	Number of FFTs per second
FFT Peak	Peak FFT Amplitude
Carrier Fx	Transmit Frequency code

Siemens	2 Channel [1]	ABC
Sets low flow limit filter		
Low Limit GAL/MIN	>0.00	
High Limit GAL/MIN	16.75	
Noise Level Set	2	
Doppler Freq	8571	
% Deviation	100.00	
Signal PK-PK mV	27	
FFT s/Sec	28	
FFT Peak	0	
Carrier Fx	27	
Application Info		

Display of "F" at No-Flow conditions

It is normal for the digital display to show an "F" for the no flow condition since the lack of Spectra information during no flow is the same as a fault condition.

Note

Selecting the [Operation Adjust] menu cell [Zero/Fault Set] allows the option of indicating Zero Flow rather than a Fault.

Selecting Liquid Composition

The width of the Spectra wave shape is an indication of the depth of penetration of sonic energy into the flow stream. The % Deviation is a measure of the width of the Spectra and is representative of the penetration of the sonic beam into the liquid.

Select [Slurry] in the [Application Data] menu for better flow rate indication accuracy when the % Deviation is less than 25 with typical flow conditions.

For % Deviations above 35, select [Liquid]. For applications that continuously have % Deviations between 25 and 35, proper selection of either [Liquid] or [Slurry] can be confirmed by comparison to a known flow reference.

Siemens	2 Channel [1]	ABC
Pick Liquid or Slurry Flow Calibration		
Liq Composition	Liquid	
Density S.G.	1.00	
Application Data		

Other Menu Entries

All other flow meter menu entries will operate and be used in the same manner as the transit time flow measurement mode.

Alarm, error, and system messages

8.1 Alarm Codes

Alarm Codes and Descriptions

The following alarm codes appear on the main display of the flow meter.

Letter Codes	Alarm Code	Description
SPACE	Spacing	Transducer spacing may need adjustment
EMPTY	Empty	Pipe is empty
HI/LO	Rate	Flow above High setting or below Low setting
FAULT	Fault	Three continuous seconds without new data update
AER	Aeration	Current aeration percentage exceeds the alarm set point
MEMRY	Memory	Last valid reading for a selected interval during Fault condition
MAKUP	Makeup	In-Process Makeup occurred
The following alarm codes appear in the Datalogger status messages:		
I	Interface	Liquid Vs exceeds interface alarm set point
Z	ZeroMatic	ZeroMatic signal occurred

The displays shown below indicate where the Alarm Codes appear on the screen. Press <UP> or <DOWN> Arrows to change screen views.

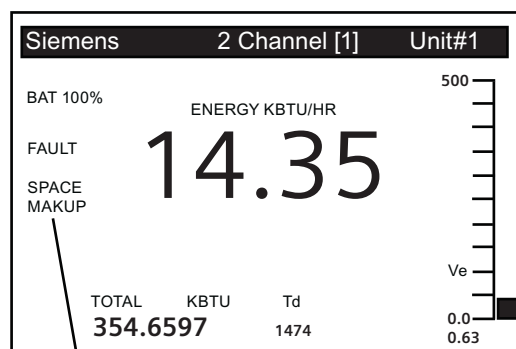

① Alarm Codes

8.1 Alarm Codes

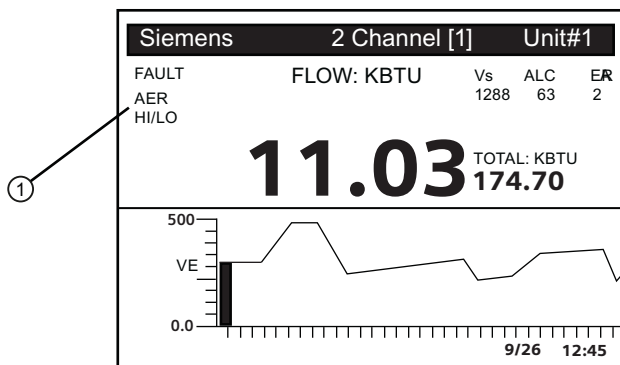

① Alarm Codes

Maintenance and service

9.1 Maintenance

The device is maintenance-free, however a periodic inspection according to pertinent directives and regulations must be carried out.

An inspection can include check of:

- Ambient conditions
- Seal integrity of the process connections, cable entries, and cover screws
- Reliability of power supply, lightning protection, and grounds

9.2 Replacing the battery

The internal battery pack used with SITRANS F 1010 portable flow meters may be removed and replaced when needed.

Battery Pack Removal/Replacement

1. Disconnect power to the unit.
2. Open the flow meter cover by releasing the two side cover latches.
3. Make sure power to unit is turned off.
4. Using a cross-head screwdriver, remove 12 screws and washers securing the faceplate. Set aside.

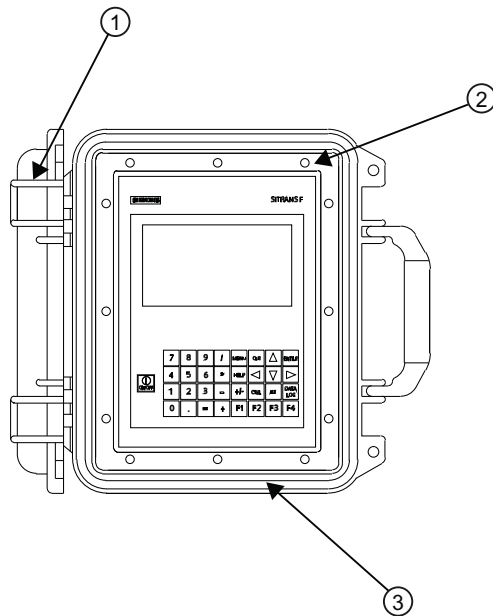

- ① Top cover release latch
- ② Faceplate screws (12)
- ③ Pry open faceplate here

Figure 9-1 Faceplate Removal

CAUTION

Wire Harness Damage

Wire harnesses can be damaged when lifting the faceplate and may expose personnel to possible injury.

When lifting faceplate make sure not to damage wire harnesses.

5. Pry up faceplate and gently lift upwards. Tilt faceplate back and rest it securely so that the inside of the flow meter is accessible but that there is no pressure on the wiring harnesses.

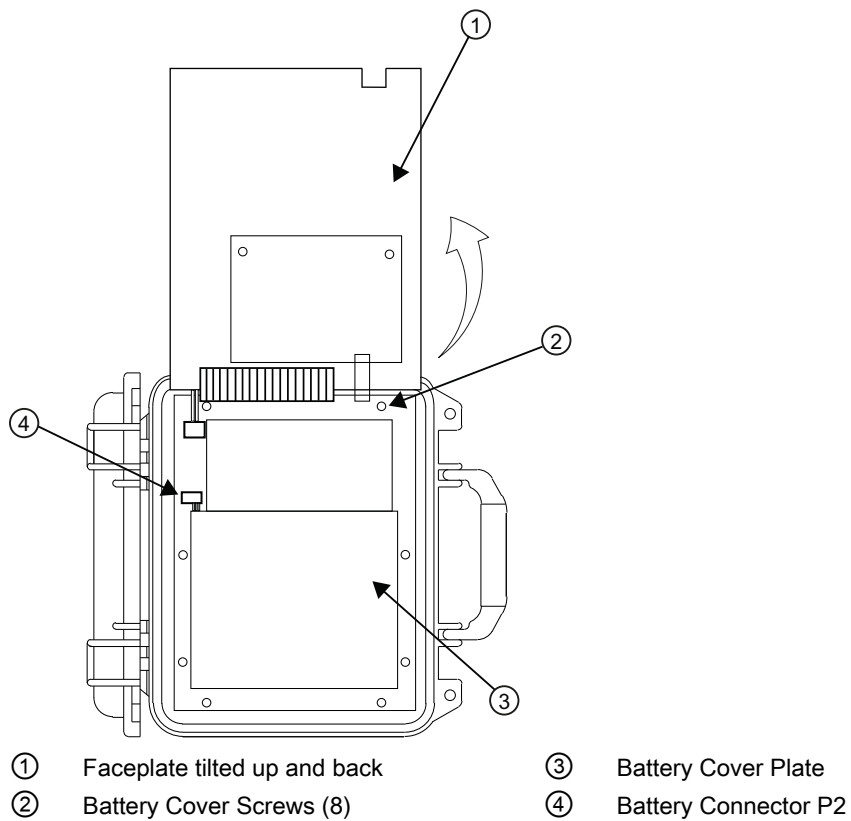
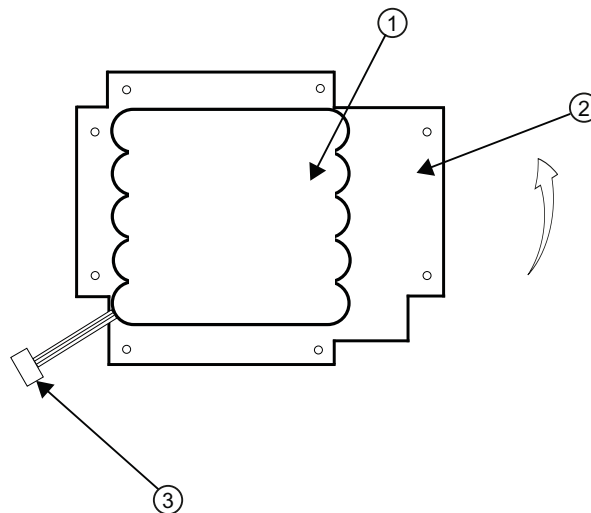

Figure 9-2 Battery Cover Removal

6. Remove 8 screws securing the battery cover. Set aside screws.
7. Disconnect pendant battery connector (J2). Note that it is a keyed-type plug.
8. Remove battery cover from unit.

9.3 Battery disposal



- ① Battery P/N 1010-107
- ② Underside of battery cover
- ③ Power Connector J2

Figure 9-3 Battery Removal/Replacement

9. Remove battery pack from battery cover.
10. Insert new battery pack into cover making sure the power connector is placed properly in the cover.
11. Reconnect battery power connector to P2.
12. Reverse the installation procedure to reassemble.

9.3 Battery disposal



In accordance with EU directive 2006/66/EC, batteries are not to be disposed of using municipal waste disposal services.

Waste industrial batteries are accepted back by Siemens or by the local Siemens representative. Please talk to your local Siemens contact (<http://www.siemens.com/processinstrumentation/contacts>) or follow the return procedures (Page 128) of Siemens.

9.4 Technical support

NOTICE
Repair and Service Repair and service must be carried out by approved Siemens personnel only.

Note

Siemens defines sensors as non-repairable products.

Technical Support

If you have any technical questions about the device described in these Operating Instructions and do not find the right answers, you can contact Technical Support:

- Via the Internet using the **Support Request:**
Service and support (<http://www.siemens.com/automation/service&support>)
- Via Phone:
 - Europe: +49 (0)911 895 7222
 - America: +1 423 262 5710 / 1 800 333-7421
 - Asia-Pacific: +86 10 6475 7575

Further information about our technical support is available in the Internet at
Local contact person (<http://www.automation.siemens.com/partner>)

Service & Support on the Internet

In addition to our documentation, we offer a comprehensive knowledge base online on the Internet at:

Technical support (<http://support.automation.siemens.com/WW/view/en/16604318>)

There you will find:

- The latest product information, FAQs, downloads, tips and tricks.
- Our newsletter, providing you with the latest information about your products.
- A Knowledge Manager to find the right documents for you.
- Our bulletin board, where users and specialists share their knowledge worldwide.
- You can find your local contact partner for the Industry Automation Division in our partner database.
- Information about field service, repairs, spare parts and lots more under "Services."

Additional Support

Please contact your local Siemens representative and offices if you have additional questions about the device

Find your contact partner at:

Support request (<http://www.siemens.com/automation/support-request>)

9.5 Return procedures

Enclose the delivery note, the cover note for return delivery and the declaration of decontamination form on the outside of the package in a well-fastened clear document pouch.

Required forms

- **Delivery Note**
- **Cover Note for Return Delivery** with the following information

Cover note (<http://support.automation.siemens.com/WWW/view/en/16604370>)

- product (ordering number)
- number of devices or spare parts returned
- reason for the return

- **Declaration of Decontamination**

Declaration of Decontamination

(http://pia.khe.siemens.com/efiles/feldg/files/Service/declaration_of_decontamination_en.pdf)

With this declaration you certify *that the returned products/spare parts have been carefully cleaned and are free from any residues.*

If the device has been operated together with toxic, caustic, flammable or water-damaging products, clean the device before return by rinsing or neutralizing. Ensure that all cavities are free from dangerous substances. Then, double-check the device to ensure the cleaning is completed.

We shall not service a device or spare part unless the declaration of decontamination confirms proper decontamination of the device or spare part. Shipments without a declaration of decontamination shall be cleaned professionally at your expense before further proceeding.

You can find the forms on the Internet and on the CD delivered with the device.

Troubleshooting

10.1 Troubleshooting

The following is list of troubleshooting tips and messages that you may encounter. They include explanations and, in some cases, a recommended action. If a problem seems unsolvable, contact your local Siemens office or regional Ultrasonic Flow Representative for expert help at <http://www.automation.siemens.com/partner> (<http://www.automation.siemens.com/partner>).

Table 10- 1 Troubleshooting Tips

Error or Message	Probable Cause	Solution
Memory Full!	Response to an attempt to save site data, when data memory is full.	Delete an obsolete site or clear Datalogger memory to make room for the new data.
Memory Corrupted!	Memory read error occurred while accessing the active site data.	Refer to F4 reset procedure in the Operation Instructions manual.
Chan Not Setup	Response to an attempt to invoke an operation that requires a channel to be enabled.	Enable the channel [Channel Setup - Channel Enable - Yes]. Note that a channel cannot be enabled until an "Install" operation is completed.
Clr Active Memory?	Response to pressing and holding the F4 key during power-up.	Use the F4 function to restore operation if a severe event (e.g., a violent power surge) disrupts system operation.
Clr Saved Data?	[Clr Saved Data?] only appears after pressing the <Down Arrow> in response to [Clr Active Memory?].	Answering Yes to [Clr Saved Data?] will erase ALL saved data. To invoke in RS-232 serial mode, type @@@ and then press <ENTER> key.
<EOT>	Response to a request to output Datalogger data to the printer or the Graphics screen when no Datalogger data exists.	Set up the Datalogger.
No Sites - Press <ENTER>	Response while trying to recall/delete a site setup when no sites are stored.	Create a site.
Security	Response upon changing previously entered data when security switch is in [Disable] position or security code has been entered.	<ul style="list-style-type: none"> Change switch position to [Enable]. Enter previously set security code.
RTC Error	Component level problem.	<ul style="list-style-type: none"> Meter requires service. Request RMA.

Error or Message	Probable Cause	Solution
- - -F- - - Fault Alarm	<ul style="list-style-type: none"> • Loss of signal strength (ALC) • Change of Rx signal location (Beam Blowing) 	<ul style="list-style-type: none"> • Recouple sensors with fresh couplant. • Install sensors in Direct mount mode. • Note: If problem persists call Tech support.
Re-space Index	The measured liquid sonic velocity (Vs) is more than +/- 25% of the average Vs range.	<ul style="list-style-type: none"> • Assure proper pipe dimensions and/or Liquid data entries are correct. • Properly enter correct Sensor Size into the meter [Install Sensor] menu. • Confirm sensor spacing is correct by checking [Install Sensor] menu spacing parameters.
Invalid Setup (use Direct Mode)	During the Initial Makeup the system detects invalid sensor spacing, erroneous liquid pipe parameters, or some other factor that prevents it from completing the Initial Makeup.	<p>This may be due to one of the following:</p> <ul style="list-style-type: none"> • An out-of-range data entry. • An invalid condition (e.g., overlapping sensors in Reflect Mode). If selecting Direct Mode does not resolve, review all site setup and sensor installation choices particularly data entered for pipe and liquid. • In Reflect Mode the flow meter detects that the pipe wall signal may infringe upon the liquid signal. Use Direct Mode instead. • Press <ENTER>, <Up Arrow>, <Down Arrow>, or <Left Arrow> to abort install routine. Continue programming other site data in anticipation of resolving the difficulty later. Call technical support for help if necessary.

Error or Message	Probable Cause	Solution
Low Signal - Press <ENTER>	During the Initial Makeup the flow meter decides that the level of the receive signal is insufficient for proper operation.	<p>Some reasons for low signal are:</p> <ul style="list-style-type: none"> • Invoking [Install Complete] on an empty pipe. • Coupling compound insufficient not applied or evaporated. • A disconnected or broken sensor cable. • The pipe needs to be conditioned at the mounting location. • Flush out large air bubbles. • The sensor cables are defective or not connected to the correct channel. • The Set Empty routine performed when pipe was NOT actually empty. <p>If you locate and correct the improper condition immediately, press <ENTER> to resume the installation procedure. Otherwise, press the <Left Arrow> to abort the installation and conduct a thorough investigation.</p>
Detection Mode	If it appears that the flow meter cannot complete an Initial Makeup it means that the pipe and/or liquid conditions do not permit a receive signal that meets the flow detection standards. The system will not operate.	<p>Attempt to improve operating conditions by reinstalling the sensors at a different spacing offset, or even at a different location on the pipe.</p> <p>Switching from Reflect to Direct Mount may solve the problem. However, operation may not be possible if there is poor liquid or pipe wall sonic conductivity.</p>

Note

If you receive a Detection Fault message, it is strongly recommended that the Technical Service Department (<http://www.automation.siemens.com/partner>) be contacted.

10.2 F4 Reset Procedure

You may encounter an operating problem that blocks access to the Diagnostics Menu, or the flow meter may operate erratically after exposure to a power transient or some other traumatic event. These cases may require use of the F4-reset sequence to restore operation.

The F4-Reset sequence operates on two levels:

- Clear Active Memory

The first F4-Reset deletes all the data currently in Active Memory, but leaves Datalogger data and all stored Site Setups intact. This is the most desirable method since all you have to do to restore operation is reload a saved Site Setup.

- Clear All Saved Memory

If the first sequence fails then you have to resort to the second level of the F4 sequence, which allows you to clear ALL Saved Memory. **Be aware that this erases all saved Site Setups (including flow calibrated sites), Datalogger Data and user-defined pipe and sensor tables.** This will require you to completely re-install the system and repeat all desired default settings, custom pipe tables, etc. The table below shows the sequence of the [F4] routine:

[Power On/Off + F4]⇒	[Clr Active Memory?]⇒	⇒No
	↑ ↓	⇒Yes
	[Clr Saved Data?]⇒	⇒No
		⇒Yes

Clearing only Active Memory

1. Turn off power (if it is currently on). Press <F4> and keep it pressed while you turn on power. The prompt: [Clr Active Memory? No] appears at the top of the screen.
2. Press <Right Arrow> to access F4 Reset option list. Press <Down Arrow> to switch the option list to [Clr Active Memory? Yes]. Press <ENTER> to clear all Active Site Data (but not saved Site Setups).
3. To restore operation, press <MENU> to access the installation menu. Create a new site setup or recall a stored site setup.
4. Re-select any Meter Facilities menu items (e.g. RS-232 setup parameters).

Clearing All Saved Data

1. Turn off power (if it is currently on).
2. Press <F4> and keep it pressed while you turn on power. The prompt: [Clr Active Memory? No] appears at the top of the screen. Press the <Down Arrow>. Note that the prompt switches to [Clr Saved Data? No].
3. To access the F4 Reset option list press the <Right Arrow>. Press the <Down Arrow> to switch the option list to [Clr Saved Data? Yes].

NOTICE**Loss of RAM Data**

Before proceeding further it is essential to understand that this function eliminates ALL data stored in RAM. This means that all saved site setups including the site data of a flow-calibrated site will be erased! In addition, the entire Datalogger file plus any custom factory or user-created pipe or sensor tables will be eliminated.

The impact of this is such that we strongly recommend that you consult Technical Services before continuing with this procedure. Be aware that you will have to create a new Site Setup, re-enter all site specific parameters including pipe or sensor tables, plus all desired Meter Facilities menu entries.

4. To clear all Saved Memory press <ENTER>.
5. Create a Site Setup before attempting to access other menu items.
6. To restore operation, press <MENU> to access the installation menu. Create a new site setup and complete the installation procedure.
7. Re-select desired Meter Facilities menu items (e.g. RS-232 setup parameters).

10.3 Test Facilities Graph Screen

When operating in the transit time mode the Test Facilities Graph Screen is an exceptional diagnostic tool for troubleshooting problem applications or simply determining Receive signal quality. The primary function of this screen is to display the digitized receive signal waveform with the similar appearance and function of a digital oscilloscope. This screen also allows the user to override some of the flow meter default settings by permitting adjustment to the measured transit time, the digital averaging and the zero crossover used in the measurement of the up/down transit time difference. The figure shown below is a representation of the diagnostic graph.

Note

The Test Facilities Graph Screen requires significant CPU overhead. The flow meter should not be left in this mode during normal operation where the Datalogger is the primary output or during calibration work.

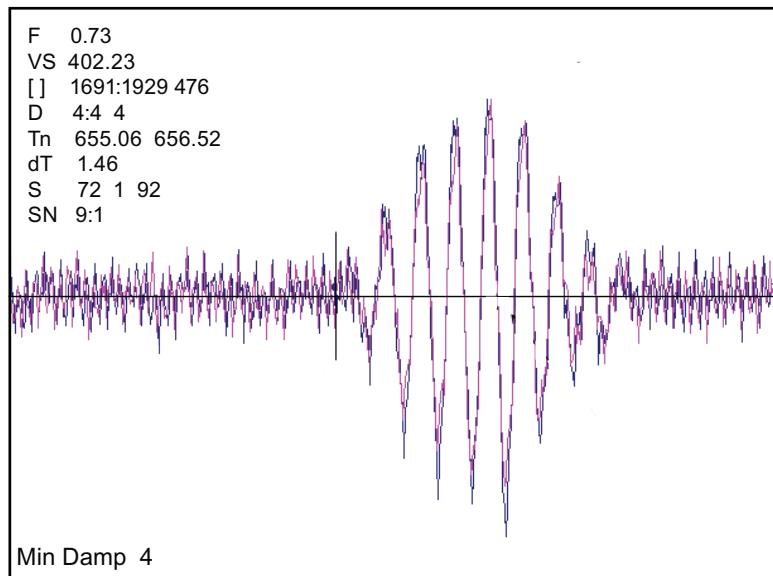

Figure 10-1 Test Facilities Graph Screen

Entering the Diagnostic Graph Screen

Before you can view the Diagnostic Graph Screen the flow channel must first be properly installed and operating in a non-empty condition. If a previously installed channel is in a "Fault" condition, but not reporting "Empty", you can still access the Graph Screen to aid in troubleshooting the cause of the failure to measure flow.

To view the Graph Screen first enter the [Test Facilities] menu, which is a submenu of the main [Diagnostic Data] menu.

1. Pressing the <Up/Down Arrows>, scroll to the [Graph] menu item.
2. Press the <Right Arrow> to enter the [Graph] menu and scroll to highlight the [Yes] item in the option list.
3. Now press the <ENTER> key to access the Graph Screen.
4. To exit the Graph Screen and return to the main menu, press the <MENU> key once.

Diagnostic Text Display

The text to the upper left-hand corner of the screen represents diagnostic items which can be individually turned on or off to reduce unnecessary clutter on the screen. This text display can be modified by pressing the <ENTER> key and scrolling up or down through the various parameters that appear in the Graph Display menu. Pressing the <ENTER> key will select the highlighted parameter (a "+" sign appears next to selected items) and pressing <CLR> will deselect the item. Pressing the <Left Arrow> will return you to the graph screen with the selected parameters appearing at the top left corner of the screen. (The sample graph above is shown with all diagnostics items selected).

Time Base Control

The digitized receive signal can be moved either to the left or right on the screen by pressing the <Left> or <Right> keypad arrows. The direction of the arrow actually represents the direction in which the Receive "window" will move, thereby causing the receive signal to shift in the opposite direction on the screen (e.g., Pressing the <Left Arrow> moves the signal to the right).

The digitized receive signal can be expanded or contracted in the time domain by pressing the <+> or <-> keys on the keypad. This allows you to see the entire contents of the receive window, or zoom in to see greater detail. Pressing the <CLR> key once will automatically center the receive signal on the screen. When expanding the Receive signal small vertical "tick" marks will eventually appear. These marks represent the time at which the receive signal is digitally sampled.

Correlated Plot

During conditions of flow, the actual transit time delta (difference) can be observed in the displayed receive signal waveform when the [Correlated Plot] menu parameter is not selected. To observe this time difference simply depress the <+> key (to see greater signal detail) until the individual up and down receive signals are clearly discernible. To verify that the flow meter signal processing algorithms are properly correlating the up and down stream receive signals, select the [Correlated Plot] option from the display menu list.

Return to the graph screen and observe the relative position of the up and down waveforms. In a properly correlated receive signal the two images should be nearly superimposed on top of each other, even during high flow conditions. In the unlikely situation where the two images appear to be offset by one or more receive cycles then the flow readings should be considered questionable.

Command Modes

Although the flow meter signal processing algorithms are capable of accommodating a very wide range of signal conditions, it may be desirable to override these default settings under extremely difficult operating conditions. The following functions are available for this purpose.

Digital Damping Control: (Hot Key 1 and 2)

The meter permits user modification of the digital averaging used by the signal processing routines. In general, the default damping values selected by the flow meter will provide optimal performance over a wide range of transit time applications. However, in extreme cases of unstable flow, pulsating flow, low signal levels or high electronic noise it may be necessary to override these default settings to permit uninterrupted and reliable flow measurement.

Test Facilities Graph Screen

The Graph Screen includes the capability to access a set of command codes, which enable a user to override a number of default meter settings. The most important parameter is the digital damping control, which can be accessed by pressing number <1> or <2> on the keypad while in the Signal Graph Screen mode.

[MinDamp #] Command

Pressing the <1> key will cause [MinDamp #] to appear on the command line at the lower left-hand corner of the screen. The number listed to the right of the command code represents the exponent in the meter exponential averaging routine, where the larger the number the greater the digital averaging. Pressing the <+> key will increase the damping value. Likewise, pressing the <-> key will decrease the damping value.

To exit this mode, press the <0> key on the keypad.

[MaxDamp #] Command

Pressing the <2> key will bring up the [MaxDamp #] command. The function of this parameter is similar to the [MinDamp #] command described above; however, the two parameters interact in the following manner. The MinDamp value must not exceed the MaxDamp value; therefore increasing the MinDamp value above the previous MaxDamp value will set both parameters to the same value. In most cases, it is preferred that both damping parameters be set to the same value, however, in cases where rapid response to changes in liquid sound velocity for flow rate is required, the two values may be set differently. In this situation the meter will use the MaxDamp value when conditions are stable, but then switch to a faster damping value (limited by MinDamp) when a significant change in sound velocity or flow rate is perceived.

To exit this mode, press the <0> key on the keypad.

To access the Digital Damping Control using the Test Facilities Graph Screen, proceed as follows:

Note

To use the Test Facilities Graph Screen you must have a working site.

To activate the Test Facilities Graph Screen:

1. In the main menu, scroll to the [Diagnostic Data] menu and select [Test Facilities].
2. Scroll down to [Graph], press the <Right Arrow> and highlight [Yes]. Press <ENTER> to select.
3. The Test Facilities Graphic Screen will appear on the meter display as shown below.

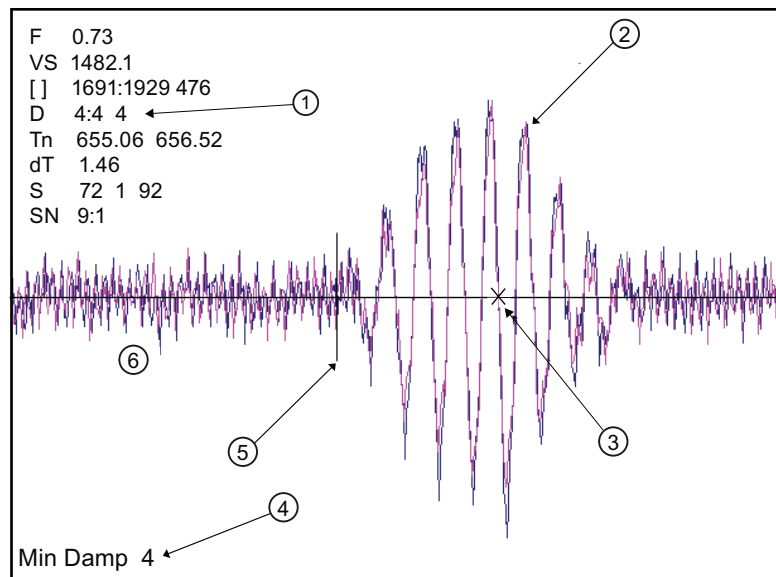

- | | |
|----------------------------|----------------------------------|
| ① Damping Factors | ④ Min Damping Factor (Hot Key 1) |
| ② Digitized Receive Signal | ⑤ TN Marker |
| ③ Crossover Marker | ⑥ High Baseline Noise |

Figure 10-2 Setting Digital Damping Factor

Setting the Digital Damping Factor to a value HIGHER than the default value of 4 may be necessary in cases where the signal-to-noise ratio (SN) is found to be unacceptably low (<15:1), but only if the noise is determined to be asynchronous (i.e., not associated with the transmit or flow meter timing circuitry) as shown in the signal example above, where the baseline noise has a higher frequency than the true liquid signal.

The following application conditions may require a higher Digital Damping Factor:

- Close proximity to pressure control valves which may generate in-band acoustic noise
- High un-dissolved gas solids content in liquid.
- High electronic noise from variable frequency drives or other external equipment.

To INCREASE the Digital Damping:

1. Press the <1> key while viewing the Test Facilities Graph Screen as shown above. The damping control [MinDamp #] will appear on the command line at the lower left-hand corner of the screen.

Note

The number listed to the right of the command code on the screen represents the exponent in the exponential averaging routine (digital damping), where the larger the number represents the greater the digital averaging. Setting this exponent higher than 7 is generally not recommended.

2. Pressing the <+> key will increase the MinDamp Factor by one unit for each key press. To exit this mode, press the <0> key on the keypad.

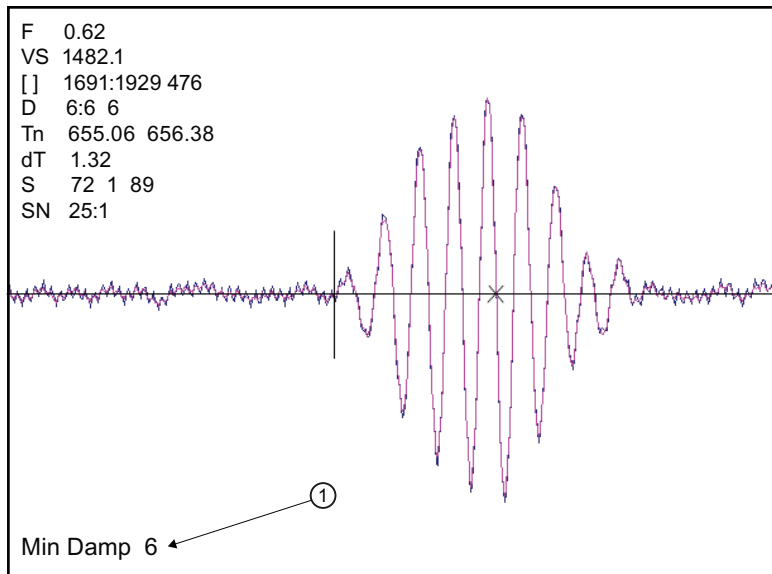

① Increased Damping Factor

Figure 10-3 Setting the MinDamp Factor

The above example shows that increasing the Digital Damping reduces asynchronous noise.

Setting the Digital Damping factor to a value LOWER than the default value of 4 may be justified in cases where pulsating flow is present (such as from a reciprocating pump) or for the purpose of diagnosing transient signal behavior. A pulsating flow condition that generates more than +/- 45 degrees of phase jitter will generally cause signal correlation problems when any digital averaging is used. In this case it may be necessary to completely eliminate the digital averaging by reducing the Digital Damping Factor to 0.

To DECREASE the Digital Damping:

1. Press the <2> key while viewing the Test Facilities Graph Screen. The damping control [MaxDamp #] will appear on the command line at the lower left-hand corner of the screen.
2. Pressing the <-> key will decrease the MaxDamp Factor by one unit for each key press. To exit this mode, press the <0> key on the keypad.

Transit Time Adjustment: (Hot Key 3)

Observe the short vertical marker at the beginning of the receive signal in the Graph Screen above. This line represents the position in time (T_n) where the flow meter perceives the arrival of the ultrasonic signal. There are actually two T_n markers, one for the upstream arrival time and one for the downstream arrival time. For proper liquid sound velocity measurement these T_n markers should be positioned near the beginning edge of the receive waveform envelope (as shown), however, in cases of poor signal conditions it is possible for this measurement to be off by several receive waveform cycles.

1. To adjust the T_n mark position press the <3> key on the keypad to bring up the [TnSet #] command.
2. Pressing the <+> or <-> keys will cause the T_n marker to move later or earlier, respectively. As you adjust the T_n marker, both T_n and V_s (liquid sound velocity) will change accordingly.
3. To exit this mode, press the <0> key on the keypad.

Zero Crossover Adjustment: (Hot Key 4)

Observe the small "X" mark located on the zero crossing line near the middle of the receive signal in the Graph Screen above. This "X" indicates the central crossover which the flow meter is using to measure the transit-time delta. This crossover will generally be close to the peak of the Receive signal with at least one well formed (non-aberrated) receive cycle on each side of the crossover.

1. If it appears that the placement of this crossover is unsatisfactory then it can be adjusted by pressing the <4> key on the keypad, which will invoke the [ZCO Set #] command. The crossover point can then be moved in either direction on the waveform using the plus <+> or minus <-> keys. The change from the default value (in receive cycles) will appear in the number to the right of the command.
2. To exit this mode, press the <0> key.

Envelope Threshold Adjustment: (Hot Key 5 & 6)

Pressing the <=> key causes the graph to toggle between the default signal waveform screen and the signal envelope screen (see example below). This envelope screen can aid in the diagnosis of Tn errors caused by unusual receive waveform distortion. Signal distortion is sometimes caused by poor sensor selection or poor pipe wall conditions, which may result in an incorrectly measured fluid sound velocity. To improve the automatic measurement of Tn, the envelope threshold limit can be adjusted to exclude portions of the envelope, which may be causing the Tn detection problem.

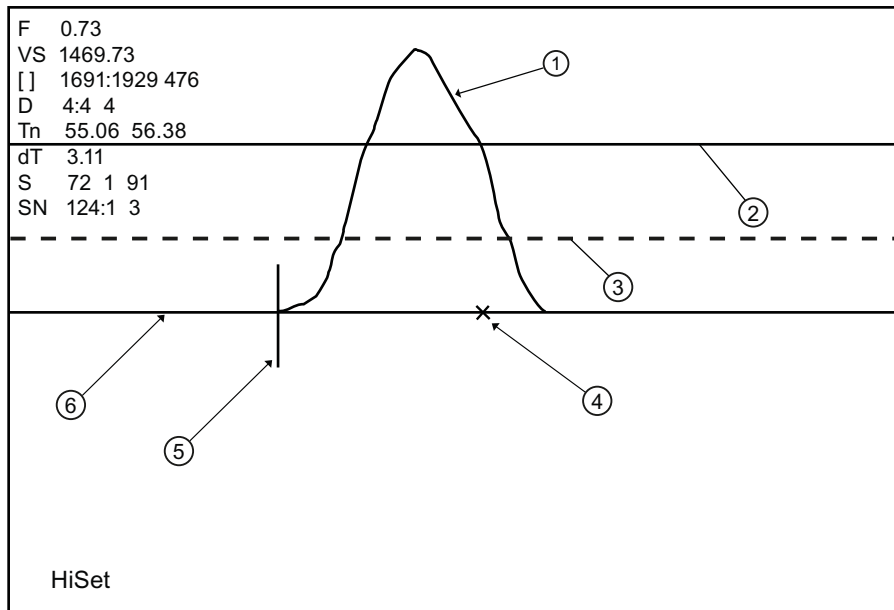

- | | |
|----------------------------|--------------------|
| ① Envelope Signal | ④ Crossover Marker |
| ② HiSet Envelope Threshold | ⑤ TN Marker |
| ③ LoSet Envelope Threshold | ⑥ Zero Baseline |

Figure 10-4 Envelope Threshold Adjustment

1. If it appears that the default placement of the Tn marker is incorrect or unstable, it can be adjusted by pressing the <5> key on the keypad to invoke the [Hi Set #] command or by pressing the <6> key to invoke the [Low Set #] command (while viewing the envelope screen). A horizontal line representing the envelope threshold level will appear along with a number indicating the percentage level. The High and Low thresholds can then be moved either up or down on the envelope using the <+> or <-> keys. While viewing the Tn marker position, adjust the thresholds so that they are well above the baseline "noise" level but below the first major peak.
2. To exit this mode, press the <0> key.

Signal Masking Function: (Hot Key 7)

Under conditions of extremely low signal amplitude, a noise spike associated with the flow meter receive signal window may be present on the extreme left side of the graph display. If this spike is large enough it may interfere with the signal detection routines.

1. To eliminate this noise from the signal processing routines, press the <7> key to invoke the [Mask Set #] command, then press the <+> key until the noise is no longer present in the receive waveform.
2. Press <0> to exit this command.

Hold Set Function: (Hot Key 8)

The [Hold Set #] command is used to set the Hold Set number higher if intermittent mis-registration occurs. Press the <8> key on the keypad to invoke this function.

Table 10- 2 Description of Graph Screen Text Display Parameters

Screen Text Parameters	Menu List Item	Description
F	Flow	Measured flow rate in selected flow units.
VS	Vs m/s	Sound Velocity in meters per second.
[]	Display Metrics	Represents the digital sample position of the receive window.
	Correlated plot	Displays the receive waveform in its proper superposition or registration. The true delta time will be displayed by NOT selecting "Correlated Plot".
	Centroid Mark	Indicates with a large vertical marker the peak energy of the receive waveform.
D	Damping	Displays the minimum and maximum digital damping exponent along with the active damping exponent.
Tn	Tn (usec)	Receive signal transit time in microseconds.
dT	DeltaT (nsecs)	Transit time delta (difference) in nanoseconds.
S	Signal Strength	Displays %Valc (amplitude), %Vaer (aeration factor) and numeric ALC.
SN	Signal-to-Noise Ratio	Indicates the signal to noise ratio of the receive signal. Increased damping will increase the S/N ratio as the asynchronous noise reduces.
	Envelope	Percentage change of the signal from Initial Makeup conditions.

Table 10- 3 Hot Key Summary

Key	Command Line	Description
<+>		Expands (magnifies) waveform to view more detail.
<->		Contracts waveform to view more of the waveform.
<Left Arrow>		Shifts receive window to the left (waveform to the right).
<Right Arrow>		Shifts receive window to the right (waveform to the left).
<CLR>		Brings waveform to the center of the screen.
<ENTER>		Calls up Text Display menu items. <Left Arrow> to return to graph.
<MENU>		Exits the Graph Screen and returns to the main menu.
<1>	MinDamp	Minimum damping exponent control (+ or - to increase or decrease).
<2>	MaxDamp	Maximum damping exponent control (+ or - to increase or decrease).
<3>	TnSet	Transit time adjustment (use + or - to move Tn marker).
<4>	ZCOSet	Zero Crossover adjustment (use + or - to move crossover marker).
<5>	HiSet	Signal envelope threshold level (use + or - to move threshold).
<6>	LoSet	Signal envelope threshold level (use + or - to move threshold).
<7>	MaskSet	Leading edge masking functions (use + or - to alter number of samples masked).
<8>	Hold Set	Set this number higher if intermittent mis-registration occurs.
<0>		Exits the command line.
<=>		Toggle graph between receive waveform and envelope waveform.
<F1> and <.>		Dumps the digitized waveform data over the RS-232 port. You must first leave the Graph Screen mode before invoking this command.

10.4 Site Setup Data

This menu provides data pertaining to sensor characteristics and operation. Some menu items are for technical support interpretation only.

Siemens	Dual Path [1]	ABC
Current transmit drive code		
fx (drive)		30
N (burst length)		5
Ltn		-1.154
Vf max		1577.42
Vs max M/S		2165.41
Vs min M/S		939.62
Empty		30
Samples/Cycle		16
Max Damping		
Min Damping		
HF		0.120
Site Setup Data		

Table 10- 4 Site Setup Menu Items

fx Drive	Current Transmit drive code selected during Initial Makeup. The drive code controls the sonic transmit signal.
N (burst length)	Transmit burst duration selected during Initial Makeup. To change N count press <Right Arrow>. At equal sign enter numeric value (1 to 9 only).
Ltn (mm/in)	Spacing distance between the sensors. It will be in inches or millimeters, depending on default units.
Vf max	The flow velocity (in selected units) corresponding to one whole cycle offset between upstream and downstream receive signals.
Vs max M/S	Maximum Vs for current sensor spacing.
Vs min M/S	Minimum Vs for current sensor spacing.
Empty	Value of Empty Alarm Setting. The meter will declare an empty status if signal strength drops below this value.
Samples/Cycle	Digital sampling rate.
Max Damping	Maximum signal damping. Use to average digital data when an unstable condition occurs.
Min Damping	Minimum signal damping. Use to average digital data when an unstable condition occurs.
HF	Flow registration correction parameter.

[HF] Menu Item

The flow meter includes a Diagnostics Menu item that permits the entry of a flow registration correction parameter labeled [HF]. This "HF" parameter is the input for a proprietary algorithm that automatically compensates for signal beam blowing, thereby extending the upper flow limit of the flow meter. The HF parameter should only be adjusted in cases where the user suspects that extreme flow velocity or a large delta-time may be causing signal correlation problems.

Using the [HF] Menu Cell

Two methods for adjusting this parameter are provided via the [HF] menu cell, located within the [Diagnostics] / [Site Setup] submenu. The "Manual" method provides direct entry of this parameter and is primarily intended for the advanced user, whereas the "Automatic" method allows the flow meter to automatically measure the required correction and install the parameter.

Guidelines for use

- This menu is only accessible for the sensor channels, not the virtual (average flow) channel of the flow meter (i.e., Diagnostics Path 1 or Path 2, but not Path 1 & 2).
- The flow meter will inhibit the "Automatic" installation of the [HF] parameter if the flow rate is insufficient (too low) to accurately measure the required correction. If the maximum flow rate for the application is relatively low then this correction is not be required.
- If the flow rate is very high and the flow meter is reporting erroneous or unstable flow, then the flow meter may already be having trouble resolving the upstream and downstream signals. In this event, it may be necessary to first lower the flow rate to a moderate level before performing the "Automatic" HF adjustment. Once this is done the flow meter should be able to properly measure the highest flow rates without problems.
- The limits of the "HF" parameter are +/- 0.7 and any attempt to manually install a larger value will cause the flow meter to abort the installation of the parameter.

Note

Pressing the <Left Arrow> at any stage prior to accepting the measured value will abort the installation and return to the previous setting.

Accessing the [HF] Function

1. At the [Meter Type] Menu, press the <Right Arrow> and then <ENTER> to select the desired Path (e.g., Dual Path Flow).
2. In the [Dual Path Flow] Menu, press the <Down Arrow> and scroll to the [Diagnostic Data] menu cell. Press the <Right Arrow> to select it.
3. In the [Diagnostic Data] Menu, highlight [Path Select] and select the desired sensor path. Press <ENTER> to select path.
4. Press the <Down Arrow> and scroll to the [Site Setup Data] menu cell. Press the <Right Arrow> to select it.

Manual Adjustment Procedure

1. In the [Site Setup Data] Menu, press the <Down Arrow> and scroll to the [HF] menu cell. Press the <Right Arrow> and a pop-up [Manual] prompt will appear as shown below.

Note

Press the <Up/Down Arrow> to select [Automatic], if desired.

2. Use the numerical keys to input the desired correction value. Press <ENTER> to input value.

Siemens	Dual Path [1]	ABC
fx (drive)		29
N (burst length)		5
Ltn		5.136
Vf max	1577.4	Adjustment
Vs max M/S		>Manual 41
Vs min M/S		939.62
Empty		
Samples/Cycle		29
Max Damping		
Min Damping		
HF		>0.000
Site Setup Data		

Siemens	Dual Path [1]	ABC
fx (drive)		29
N (burst length)		5
Ltn		5.136
Vf max	1577.4	>Manual
Vs max M/S		= 0.120 41
Vs min M/S		939.62
Empty		
Samples/Cycle		29
Max Damping		
Min Damping		
HF		>0.000
Site Setup Data		

3. The new correction value will appear next to the [HF] menu cell as shown below.

Siemens	Dual Path [1]	ABC
fx (drive)		29
N (burst length)		5
Ltn		5.136
Vf max		
Vs max M/S		
Vs min M/S		1355.00
Empty		
Samples/Cycle		29
Max Damping		
Min Damping		
HF		>0.120

Site Setup Data

Automatic Adjustment Procedure

1. In the [Site Setup Data] Menu, press the <Down Arrow> and scroll to the [HF] menu cell. Press the <Right Arrow> and a pop-up [Manual] prompt will appear.
2. Press the <Up or Down Arrow> to select [Automatic] then press <ENTER>.
3. The current measured correction value is displayed (see below).
4. Press <ENTER> again to install this correction value which will now appear next to the [HF] menu cell.

Note

The value shown in the [Automatic] pop-up prompt can not be changed and is for user information only.

Siemens	Dual Path [1]	ABC
fx (drive)		29
N (burst length)		5
Ltn		5.136
Vf max	Adjustment	
Vs max M/S	>Automatic	
Vs min M/S		939.62
Empty		
Samples/Cycle		29
Max Damping		
Min Damping		
HF		>0.000
Site Setup Data		

Siemens	Dual Path [1]	ABC
fx (drive)		29
N (burst length)		5
Ltn		5.136
Vf max	>Automatic	
Vs max M/S	= 0.026	
Vs min M/S		939.62
Empty		
Samples/Cycle		29
Max Damping		
Min Damping		
HF		>0.026
Site Setup Data		

5. If you decide not to use the [Automatic] selection, press any key other than <ENTER> to abort the operation.

Technical data

11.1 Technical Data

Temperature Range	Degree of Protection
Operating: -18°C to 60°C (0°F to 140°F) Storage: -20°C to 60°C (-4°F to 140°F)	IP40 (NEMA 1)

Performance

The following specifications apply under standard conditions (i.e., measurements taken on a straight run of 15 diameters upstream and 5 diameters downstream; flow rate above 1 fps; non-aerated Newtonian liquids flowing at Reynolds numbers <2000 or >10000).

Table 11- 1 Performance Specifications

Transit-Time Accuracy	At least $\pm 1\%$ to $\pm 2\%$ of indicated flow (better than $\pm 0.5\%$ possible with calibration.)
Flow Sensitivity	0.0003 m/s (0.001 fps) - even at zero flow.
Zero Drift Stability	Less than 0.005 m/s (0.015 fps)
Batch Repeatability	$\pm 0.15\%$ of flow
Response Rate (Damping)	SmartSlew effective from 0.2 seconds to 5 minutes.
Flow Velocity Range	Min. ± 12 m/s (± 40 ft/s), inc. zero flow
Linearity	0.001 m/s (0.003 ft/s)
Flow Profile Compensation	Automatic Reynolds number correction of reported flow rate.

Appendix

A.1 Ordering

In order to ensure that the ordering data you are using is not outdated, the latest ordering data is always available on the Internet: Process instrumentation catalog (<http://www.siemens.com/processinstrumentation/catalogs>)

A.2 I/O Connections and Wiring

Terminal Block Wiring - FUE1010 IP40 (NEMA 1) Battery Powered Dual Channel/Dual Path Flow Meter Wiring

(Refer to manual drawing 1010EWDP-7 sheet 2 of 2)

The terminal block wiring table applies to the part numbers listed below.

Table A- 1 Part Numbers and Connection Data

1010EWDP-7 (Sheet 2 of 2) Drawing	
FUE1010	7ME3502

Table A- 2 Dual Channel/Dual Path Input/Output DB-25 Connector Wiring

Pin#	Signal	Function	Description
1	GND	Signal Ground	Return For Signals
2	N/C	N/C	No Connection
3	R1B	Logic Out 1	Logic Level State (HIGH=5 to 3 VDC; LOW= 1 to 0 VDC)
4	N/C	N/C	No Connection
5	R2B	Logic Out 2	Logic Level State (HIGH=5 to 3 VDC; LOW= 1 to 0 VDC)
6	N/C	N/C	No Connection
7	R3B	Logic Out 3	Logic Level State (HIGH=5 to 3 VDC; LOW= 1 to 0 VDC)
8	N/C	N/C	No Connection
9	R4B	Logic Out 4	Logic Level State (HIGH=5 to 3 VDC; LOW= 1 to 0 VDC)
10	PGEN1	Frequency Output 1	Assignable Logic Level Pulse Train (5V TTL CMOS Logic)
11	PGEN2	Frequency Output 2	Assignable Logic Level Pulse Train (5V TTL CMOS Logic)
12	Vo1	Voltage Output 1	Assignable (0 to 10 VDC) [Min. load=5k ohms]
13	Vo2	Voltage Output 2	Assignable (0 to 10 VDC) [Min. load=5k ohms]
14	Io1	Current Output 1	Assignable 4 to 20mA output 4-20mA outputs also provide a fault indication by dropping to 2mA if assigned to flow rate and under fault conditions.

Pin#	Signal	Function	Description
15	Io2	Current Output 2	Assignable 4 to 20mA output 4-20mA outputs also provide a fault indication by dropping to 2mA if assigned to flow rate and under fault conditions.
16	Io PWR	External Current Loop	User supplied 18 to 30 VDC @ 25mA min.
17	GND	Signal Ground	Return For Signals
18	CNTRL1	Logic In 1	TTL Level State [HIGH=5 to 3 VDC; LOW=1 to 0 VDC]
19	CNTRL2	Logic In 2	TTL Level State [HIGH=5 to 3 VDC; LOW=1 to 0 VDC]
20	CNTRL3	Logic In 3	TTL Level State [HIGH=5 to 3 VDC; LOW=1 to 0 VDC]
21	CNTRL4	Logic In 4	TTL Level State [HIGH=5 to 3 VDC; LOW=1 to 0 VDC]
22	Iin1	Current Input 1	External sensor input (4-20mA) [Load = 250 ohms]
23	Iin2	Current Input 2	External sensor input (4-20mA) [Load = 250 ohms]
24	N/C	N/C	No Connection
25	GND	Signal Ground	Return For Signals

A.3 Site Setup For SITRANS F

How to use the Windows HyperTerminal Program

Note

Si-Ware

If you want to use the Si-Ware program instead of HyperTerminal, download the program at [<http://s13.me/ns/cv>] and follow the setup instructions.

Windows provides a communication program called HyperTerminal, which is ideal for interfacing your computer with the flow meter. The following typical example explains how to set up HyperTerminal.

Note

Depending upon the Windows applications being used this setup procedure may vary.

1. From the Windows desktop, left-click on the [START] button.
2. Holding down the left mouse button, move the highlight up to [Programs], then across to [Accessories] then [Communications]. Slide the highlight down to [HyperTerminal], then release the left mouse button.
3. Within the HyperTerminal window, move the mouse pointer down to [Hyperterm.exe] and then double-click the left mouse button.
4. This selects the [Connection Description] dialog box. Enter a name for your connection (e.g., 1010N). You can optionally select an icon for this connection by clicking on one of the icons displayed in the scrolling frame at the bottom of the window. Click [OK].

- This selects the [Phone Number] dialog box. Move the cursor to the arrow at the right of the [Connect Using] field. Left click on the arrow to expand the field and then move the highlight down to [Direct to Com 1 (or 2)] depending on the port connected to the interface cable. Click [OK] to select the [Com 1 (or 2) Properties] Dialog box. Set up your RS-232 parameters as shown in the example below. Left-click on the [OK] button.

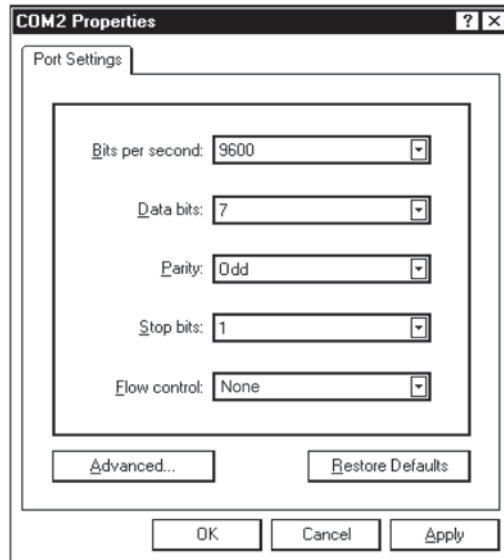

- You will now see a blank terminal screen. Next left-click [File] on the top menu bar. Drag the highlight down to [Properties] and then left-click.
- Left-click the [Settings] tab. Expand the [Emulation] box by left-clicking the <Down Arrow> on the right-hand side. Drag the highlight down to [VT-100] and then left-click to select it (as shown below).

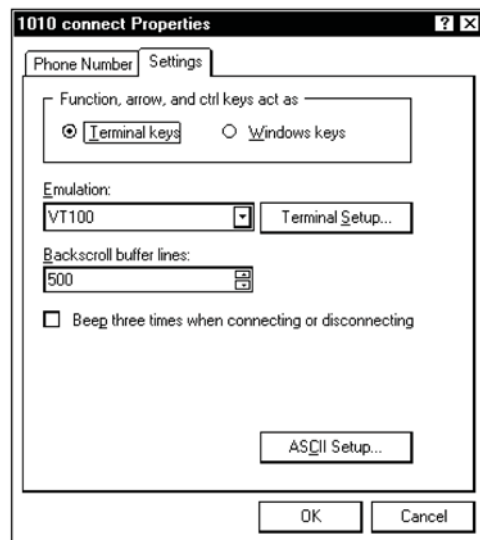

- Next, left-click on the [ASCII Setup] button (see screen above). In the [ASCII Sending] dialog box, make sure that both [send line ends with line feeds] and [Echo Typed characters locally] are UNCHECKED. In the [ASCII Receiving] dialog box, left-click to place a check mark before the [Append line feeds to incoming line ends] dialog. When your screen looks like the example below, left-click the [OK] button.

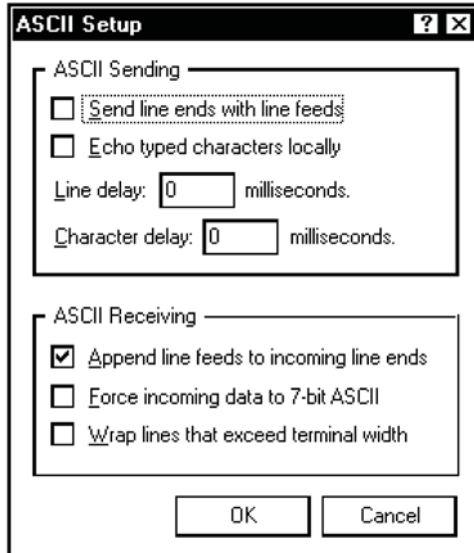

- You are now ready to communicate with the 1010 flow meter. But first, save your settings by moving the mouse cursor to [File], sliding the cursor to [Save], then clicking [OK] on the Save dialog box.
- The next time you want to use HyperTerminal:
 - Click on Start.
 - Drag to Programs.
 - Drag to Accessories. Drag to [Communications], and click.
 - Double-click the icon you selected for the connection.

Note

For easier access, create a shortcut to the connect icon from your desktop. Right-click on the icon to open its dialog box. Left-click on [Copy] or [Create a Short Cut] and then move the mouse cursor to a blank area on your desktop. Right-click to open dialog box and then left-click on [Paste] to place a shortcut to the connect icon on your desktop.

Accessing the Installation Menu

Once the parameters are set, HyperTerminal automatically initiates Command mode. You will see a blank screen.

- Press <Enter> key a few times until you see [? For Help] on the screen.
- Type: ? (question mark) and then press <Enter> key to see a list of the available commands.

Use the MENU command (type [Menu] and then press <Enter> key) to access the top level of the Installation Menu. You will see a screen similar to the example below.

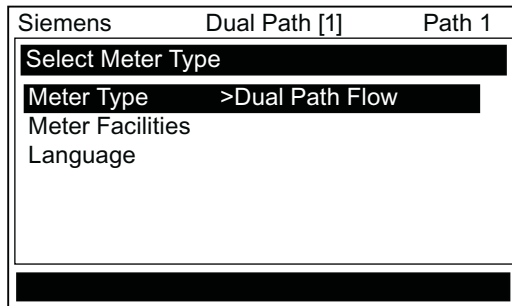

Note

To facilitate connecting through modems, the [Menu] command times out after three minutes of inactivity. To maintain a longer connection, type: Menu 1000 and press <Enter> key. The optional number is the amount in minutes that the connection will be maintained. Typing [Menu 1000] essentially keeps the interface active until you cancel it.

Data Display Mode

After you complete the installation, you can toggle between Installation Menu mode to Data Display mode. This is the same as using the <MENU> key on the transmitter keypad. The PC keyboard equivalent to the <MENU> key is <Ctrl> + <L>. Note that the RS-232 interface does not support graphics. Therefore, when you use HyperTerminal to view the data display screens, you will see the same data in alphanumeric form only (as shown below). You can still use the <Up Arrow> and <Down Arrow> to switch between available display screens.

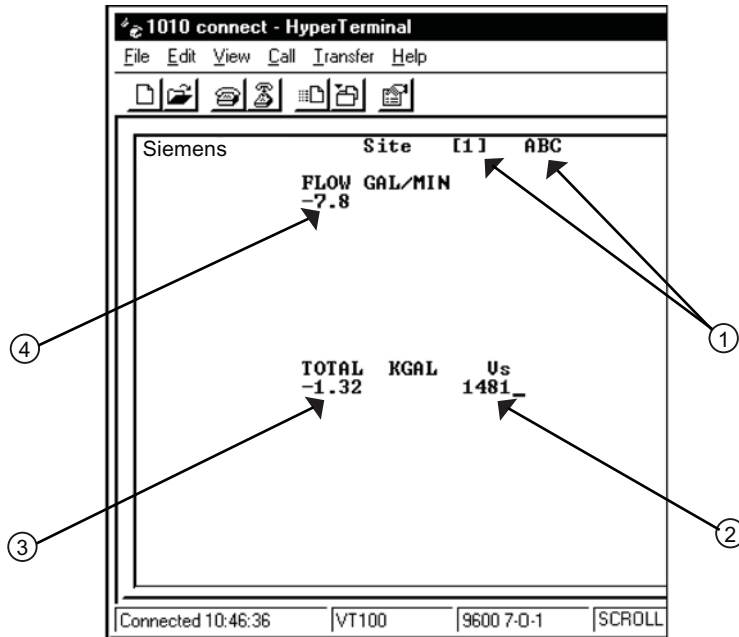

- ① Current active site setup name. The [1] indicates that the measurement channel is active.
- ② The current measured sonic velocity.
- ③ The flow Total display.
- ④ The current flow reading and flow units.

Navigating through the Installation Menu

After accessing the Installation Menu, you can begin to setup your flow meter according to the instructions in this manual. The chart below shows the PC keyboard equivalents to the transmitter keypad keys while you are in the menu.

SITRANS F 1010 Keypad	PC Keyboard	Description
<Up Arrow>	<Up Arrow>	Move up 1 menu cell (or Flow Display screen)
<Down Arrow>	<Down Arrow>	Move down 1 menu cell (or Flow Display screen)
<Right Arrow>	<Right Arrow>	Move right 1 menu cell (or Flow Display screen)
<Left Arrow>	<Left Arrow>	Move left 1 menu cell (or Flow Display screen)
<MENU>	^L (Cntrl L)	Toggle between Menu and Flow Display
<DATALOG>	^D (Cntrl D)	Generate Datalogger report
<CLR>	<Backspace> or 	Deselect list selection
<ALT+Up Arrow>	^U (Ctrl U)	Logger Display Page Advance
<+/-> (chg sign)	(bar, shift + backslash)	Change numeric sign. Can also type (-) key
<ENTER>	<Carriage Return>	Enter Key
Digits	Digits	Numerals 0 through 9
/	/	Divide by
X	* (shift + upper case 8)	Multiply by
+	+	Plus
-	-	Minus
=	=	Equals
.	.	Decimal Point

Terminal Mode Menu Commands

In addition to Menu, the following commands (followed by the <ENTER> key) can be used to control the flow meter while in Terminal Mode.

Note

The "n" refers to the flow meter Channel number. For a dual channel Arithmetic site (Ch1 + Ch2 or Ch1 – Ch2) the virtual Channel is number 3.

Logger

Invokes the download of all data stored in the Datalogger. Note that the Datalogger data is not erased from the flow meter memory when it is downloaded. It is recommended to capture this information into a file with a "csv" extension, which can be easily imported into MS Excel.

SITE

Invokes a full site download for a single channel or multi-path 1010 flow meter.

SITE "n"

Invokes a site download for channel "n", where "n" = the Channel # (1, 2, 3, 4, etc.).

DP "n"

Commands the flow meter to download the digitized receive signal data for Channel or Path "n".

CLRTOT

Clears the Totalizer for a single channel or multi-path 1010 flow meter.

CLRTOT "n"

Clears the Totalizer for Channel "n" of a multi-channel flow meter.

Lf on

Turns on the Line Feed at the end of any text string sent by the flow meter.

Lf off

Turns off the Line Feed at the end of any text string sent by the flow meter.

?

Provides a list of available Terminal Mode flow meter commands.

Transferring information from a 1010 Flow Meter to the PC

With HyperTerminal active:

1. Point to [Transfers] and click.
2. Select [Capture Text].
3. Select desired drive path or directory, enter a file name, and click the Start button.
4. Use the following conventions for data file names:
 - For site data or Waveshape data: filename.txt
 - For Datalogger data: filename.csv
5. On PC type the proper command for the data desired (Logger, Site, or DP) and then [Enter].
6. The data now begins streaming on the HyperTerminal screen.

7. Wait for EOT (End Of Transmission) to be displayed.
8. Close the file by pointing to [Transfer], drag to Capture Text and click Stop button.

Closing the Terminal or HyperTerminal Program

You may now close the Terminal program. The file(s) you have downloaded are now saved in the location you selected. You may now import the file you have saved into the appropriate program (i.e., MS Word for site data, or MS Excel for Datalogger or Wave shape data for graphing or analysis).

The Datalogger contains data that has its fields separated by commas. By using the file extension ".csv" (comma separated values) suggested earlier, the data will import directly into MS Excel without any further modification. For the wave shape data, the fields are separated by spaces, therefore, it is best to save those files as .txt and then use the MS Excel Import Wizard to select "Space Delimiters" for importation of the data.

Site data is downloaded in plain text and can be imported directly into MS Word.

To Clear Active Memory using the RS-232 Interface

1. Turn off power (if it is currently on). Turn power on. As soon as you apply power, immediately type the @ character three times. The prompt: **[Clr Active Memory? No]** appears at the top of the screen.
2. Press the <Right Arrow> and then the <Down Arrow> to switch the option list to: **[Clr Active Memory? Yes]** Press <ENTER> to clear all Active Site Data (but not saved site setups).
3. To restore operation, press <MENU> to access the Installation Menu. Create a new site setup or recall a stored site setup. Re-select any Meter Facilities items (e.g., RS-232 setup parameters).

To Clear All Saved Memory using the RS-232 Interface

NOTICE

Loss of RAM Data

Before proceeding further it is essential to understand that this function eliminates ALL data stored in RAM. This means that all saved site setups including the site data of a flow-calibrated site will be erased! In addition, the entire Datalogger file plus any custom factory or user-created pipe or sensor tables will be eliminated.

The impact of this is such that we strongly recommend that you consult Technical Services before continuing with this procedure. Be aware that you will have to create a new Site Setup, re-enter all site specific parameters including pipe or sensor tables, plus all desired Meter Facilities menu entries.

1. Turn off power (if it is currently on).
2. Turn the power on. As soon as you apply power, type the @ character three times.
 - The prompt: **[Clr Active Memory?]** appears at the top of the screen. Press the <Down Arrow>.

Note

The prompt switches to **[Clr Saved Data? No]**.

3. Press the <Right Arrow> and then the <Down Arrow> to switch the option list to: **[Clr Saved Data? Yes]**.
4. Press <ENTER> to clear all Saved Site Data, Datalogger Data, User created Pipe Data and Sensor Data.
5. To restore operation, press <MENU> to access the Installation Menu and create a new site setup. Reselect any Meter Facilities items (e.g., RS-232 setup parameters).

A.4 Flowrate Calibration and Calibration Tables

Flowrate Calibration Methods

SITRANS F 1010 equipment provides three ways to condition the calibration performance of its flowrate output: Intrinsic (factory set), Kc, and Calibration Tables 1 through 3. Access to these calibration options is found in the [Calibrate Flowrate] menu cell and the three [Calib. Table] menu cells of the [Span/Set/Cal] menu.

Intrinsic

When selected, the flow meter uses no slope adjustment at all. Output data is still zeroed and corrected for Reynolds number, but no slope adjustment is imposed on the flow meter's flow register.

Some applications may require an output adjustment to match an official external reference. The [Calibrate Flowrate] menu allows you to select a calibration mode. The right-hand column shows the active calibration mode. You can select Intrinsic (factory) and Kc (Slope Correction) Calibration. Selecting either of the external calibration modes will not eliminate the Intrinsic (factory) calibration. You can use this menu cell to switch between Intrinsic and Kc at any time.

Kc Calibration

For most applications, the measured flow range produces a linear meter response. Therefore, the Kc (slope correction) calibration is the preferred method since it only requires a single correction factor for all the flow rates encountered.

Note

Changing the calibration can cause profound changes in flow meter operating characteristics. Use only the most respected flow standard to obtain a correction factor. The percentage entered must provide an accurate and consistent shift across the entire flow range anticipated for the application.

Kc Factor

To obtain the Kc factor, compare flow total data taken simultaneously from the flow meter and a reference meter whose accuracy meets the required standard. Allow both meters to accumulate flow total data long enough to average out any differences due to flow fluctuation between the two meter locations. Compare outputs of the two totalizers to determine percentage increase (+) or decrease (-) that is necessary to produce the best average correlation between the flow meter and the reference standard.

Selecting the Kc Factor

When the [Kc] menu cell is selected, the flow meter imposes this percentage slope adjustment of its rate output. Output data is zeroed and corrected for the Reynolds number (flow profile compensated), however, a percent change in the rate output is imposed based on the data entered in this cell. The number entered by the user is evaluated into a slope correction factor by dividing it by 100 and algebraically adding it to 1. The resulting factor is used as a multiplier on the rate register of the instrument. Thus an entry of -3% will multiply the rate register by 0.97, for example.

To calculate Kc:

$$Kc = \left[\frac{\text{Actual Rate}}{\text{Indicated Rate}} - 1 \right] \times 100$$

To enter the Kc Factor

1. To enable numeric entry press <Right Arrow>.
2. Use the numeric keys to type the required Kc (as calculated above). Note that the Kc value can be negative or positive. Enter the - or + sign first, then type in the calibrated value.
3. To store the data press <ENTER>. Note that Kc now appears in the right-hand column of the [Calibrate Flow Rate] menu cell with its new value. Also note that this Kc value can be viewed on the site printout.

Calibration Tables 1 through 3

SITRANS F 1010 instruments offer a unique methodology by which a particular flow response of an instrument may be linearized or optimized by tabulating the results of a series of calibration exercises or collected batch data points. Basically, the flow meter allows the user to select any of a wide variety of system variables (flow rate, pressure, viscosity, etc.) as a pointer into a table of calibration factors (up to 32). As the system variable is updated, the value of the table's output factors (or positive and negative flow) is re-evaluated and used as a modifier for the current rate register. Note that the flow register is still zeroed and Reynolds number compensated normally and these slope corrections are in addition to these fundamentals.

Note

Kc is still active when this method is being used.

To install a Calibration table:

1. The user selects a system variable that appears to correlate strongly with calibration shifts observed.
2. A table of values is formed comprised of the values that this index could assume over the range of system operation. Remember, the tables created do not extrapolate beyond their end points, they "clip."
3. A calibration factor, a number usually close to 1.00, is entered as a positive and a negative flow rate correction factor (termed PosFlow Corr and NegFlow Corr) for each of the desired index points.

The table may contain up to 32 pairs of these slope correction factors. Note that the Kc factor, unlike these slope correction factors, is entered as a signed percent change in rate, while these factors are simply rate multipliers. As points are entered, the point editor will provide list access to the already entered points plus access to the [New Point] menu cell, used to add a new point. The table may be created in its entirety and then activated by selecting [Yes] in the [Table Active] menu cell. The entire table may be cleared by selecting [Yes] in the [Clear Table] menu cell.

Note

Careless use of the calibration tables can have a detrimental impact on the measurement performance of the flow meter.

Note

Take precautions before enabling these calibration tables. Although it is unlikely that all three tables would ever be employed in a real installation, three tables are offered for maximum user flexibility. Since the tables can be disabled without being destroyed, 2 or 3 optimization strategies may be tested by this means in order to determine which approach is most effective.

Appendix

B.1 Installation/Outline Drawings

Installation/Outline Drawings

The following are the installation and outline drawings for the SITRANS FUE1010 portable energy flow meter.

- 1010EWDP-7 - Installation Drawing, Dual Channel Portable Energy Flow Meter
- 1010EWDP-8 - Outline Dimensions, Dual Channel Portable Energy Flow Meter
- 1012Z-8 - Outline Dimensions, EZ Clamp Mounting Kit
- 1012BP-8 - Outline Dimensions, 1010 Series Spacer Bar
- 1012FP-8 - Outline Dimensions, 1011 Series Portable Transducer Mounting Frames
- 1011PPS-8 - Outline Dimensions, 1010 Series Portable Plastic Transducer
- 1012FPH-8 - Outline Dimensions, 1011H Series Portable Transducer Mounting Frames
- 1011HNFS-7 - Installation Drawing, 1011HNFS Series Plastic Transducers
- 1011HNFS-8 - Outline Dimensions, 1011HNFS Series Plastic Transducers
- 1012ML-8 - Outline Dimensions, Ladder Chain Mounting Kit
- 1012TP-7 - Installation Drawing, 1012TP Series Mounting Tracks
- 1012TP-8 - Outline Dimensions, 1012TP Series Mounting Tracks
- 1012TPH-7 - Installation Drawing, 1012TPH Series Mounting Tracks
- 1012TPH-8 - Outline Dimensions, 1012TPH Series Mounting Tracks
- 1015BC-1W-8 - Outline Dimensions, Portable Power Adapter/Battery Charger
- 1015BW-8 - Outline Dimensions, 1010 Portable Auxiliary Battery
- 1012THP-7 - Installation Drawing, 1010 Series Transducers and Mounting Tracks
- 1012TP-S-8 - Outline Dimensions, 1012TP-S Series Mounting Track
- 1012TPH-S-8 - Outline Dimensions, 1012TPH-S Series Mounting Track
- 1012TPH-8 - Outline Dimensions, 1012TPH Series Mounting Track
- 1015BC-1-8 - Installation/Outline Dimensions, 1010 Portable Power Adapter/Battery Charger
- 1015WP-T10-8 - Installation/Outline Drawing, Test Connector Interface
- 1015WP-T26-8 - Installation/Outline I/O Connector Interface
- 990TDMVH-7A - Installation Drawing, 990 Series Transducer and Tracks, Very High Temperature, Direct Mode
- 990TDMVH-7B - Installation Drawing, 990 Series Transducer and Tracks, Very High Temperature, Direct Mode

B.1 Installation/Outline Drawings

990TRMVH-7A - Installation Drawing, 990 Series Transducers and Tracks, Very High Temperature, Reflect Mode

990TRMVH-7B - Installation Drawing, 990 Series Transducers and Tracks, Very High Temperature, Reflect Mode

191P1-7 - Installation Drawing, 191P1 Portable Transducer

191P1-8 - Outline Dimensions, 191P1 Portable Transducer

991TP-7 - Installation/Outline 991T Temperature Sensor/Portable

991TP-7A - Installation/Outline 991T Temperature Sensor/Pipe or Tube OD, Range 1/2-inch to 2 inches

991TW-8 - Installation/Outline, Insert Temperature Sensor, 990E System

INPUT/OUTPUT CONNECTORS (SEE WIRING VIEW, ZONE 4A)

TERMINAL	SIGNAL	FUNCTION	DESCRIPTION	USE	LOAD	WIRING	CABLE LENGTH	NOTES
1	GND.	SIGNAL GROUND	RETURN FOR SIGNALS			#18-#22 AWG	1000 FT. MAX.	
2								
3	R1B	LOGIC OUIT 1	LOGIC LEVEL STATE	STATUS INDICATOR/ALARM	10 LOADS MAX.			SEE NOTE 5a
4								
5	R2B	LOGIC OUIT 2	LOGIC LEVEL STATE	STATUS INDICATOR/ALARM	10 LOADS MAX.			SEE NOTE 5a
6								
7	R3B	LOGIC OUIT 3	LOGIC LEVEL STATE	STATUS INDICATOR/ALARM	10 LOADS MAX.			SEE NOTE 5a
8								
9	R4B	LOGIC OUIT 4	LOGIC LEVEL STATE	STATUS INDICATOR/ALARM	10 LOADS MAX.			SEE NOTE 5a
10	P0EN1	FREQUENCY OUTPUT 1	ASSIGNABLE LOGIC LEVEL PULSE TRAIN	PULSE TRAIN FLOW MEASUREMENT	5 LOADS MAX.			SEE NOTE 5a
11	P0EN2	FREQUENCY OUTPUT 2	ASSIGNABLE LOGIC LEVEL PULSE TRAIN	PULSE TRAIN FLOW MEASUREMENT	5 LOADS MAX.			SEE NOTE 5a
12	V01	VOLTAGE OUTPUT 1	ASSIGNABLE 0 TO +10VDC	RECORDING, MONITORING ETC.	5K Ω MIN.			
13	V02	VOLTAGE OUTPUT 2	ASSIGNABLE 0 TO +10VDC	RECORDING, MONITORING ETC.	5K Ω MIN.			
14	I01	CURRENT OUTPUT 1	ASSIGNABLE 4 TO 20mA	RECORDING, MONITORING ETC.	0-1000 Ω @ 30VDC 0-450 Ω @ 18VDC			
15	I02	CURRENT OUTPUT 2	ASSIGNABLE 4 TO 20mA	RECORDING, MONITORING ETC.	0-1000 Ω @ 30VDC 0-450 Ω @ 18VDC			
16	I0 POWER	EXTERNAL LOOP PWR	USER SUPPLIED +18 TO +30VDC	DRIVE CURRENT OUTPUTS	50mA MIN.			
17	GND.	SIGNAL GROUND	RETURN FOR SIGNALS					
18	DNTR1	LOGIC IN 1	TTL LEVEL STATE	NOTOT CH-1	100K Ω			SEE NOTE 5b
19	DNTR2	LOGIC IN 2	TTL LEVEL STATE	NOTOT CH-2	100K Ω			SEE NOTE 5b
20	DNTR3	LOGIC IN 3	TTL LEVEL STATE	CLRTOT CH-1	100K Ω			SEE NOTE 5b
21	DNTR4	LOGIC IN 4	TTL LEVEL STATE	CLRTOT CH-2	100K Ω			SEE NOTE 5b
22	IN1	CURRENT INPUT 1	4 TO 20mA	EXTERNAL SENSOR INPUT	200 Ω			FLOWMETER LOAD
23	IN2	CURRENT INPUT 2	4 TO 20mA	EXTERNAL SENSOR INPUT	200 Ω			FLOWMETER LOAD
24								
25	GND.	SIGNAL GROUND	RETURN FOR SIGNALS					

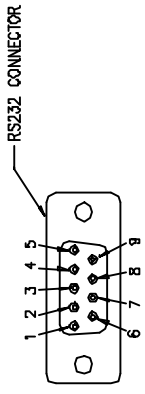

RS 232 (DB9 CONNECTOR)

PIN	SIGNAL	DESCRIPTION	BA. CABLE	WIRING	CABLE LENGTH
2	RXD	STANDARD RS 232 SIGNAL LEVELS	BB	SHIELDED DATA CABLE	DEPENDS UPON BAUD RATE
3	TXD	ALL CONTROL LINES ARE DEFAULTED TO READY STATE	BA	24 GA. MIN.	50 FEET AT 9600 BAUD WITH STANDARD CABLE
4	DTR		CD		
5	GND.		AB		
7	RTS		CA		
8	CTS		CB		

USE CABLE 1015CP-P TO CONNECT TO A SERIAL PRINTER
USE CABLE 1015CP-P TO CONNECT TO A LAP TOP / PC SERIAL PORT

I/O CONNECTOR (DB25 CONNECTOR)

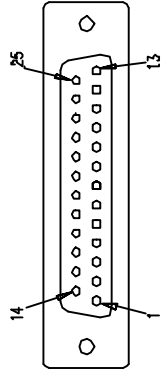

MATES WITH STANDARD DB25 MALE CONNECTORS (NOT SUPPLIED) BREAKOUT BOXES, PROVIDING TRANSITION FROM DB25 CONNECTORS TO DISCRETE TERMINALS ARE AVAILABLE FROM MANY DATA I/O PERIPHERALS SUPPLIERS, eg. PC2 CONTROL SYSTEMS @ (888) 560-8866.

CONTROLTRON
HAUPPAUGE • NY 11768

**INSTALLATION WIRING,
UNIVERSAL, PORTABLE
ENERGY FLOWMETER**

SIZE	CODE DEV. NO.	REV.
C	21614	1010EWDP - 7
SCALE: NONE		WT.
		SHEET 2 OF 2

DO NOT SCALE THIS DRAWING
UNLESS OTHERWISE SPECIFIED-
DIMENSIONS ARE IN INCHES (MM)

INCHES (MM)
± .1 (± 2)

CONTRACT NO. _____

DATE 10/16/86

DR. H.J. _____ DATE _____

CHK. _____ DATE _____

ENG. _____ DATE _____

PROJ. _____ DATE _____

APPR. _____ DATE _____

CERTIFIED _____

DATE _____

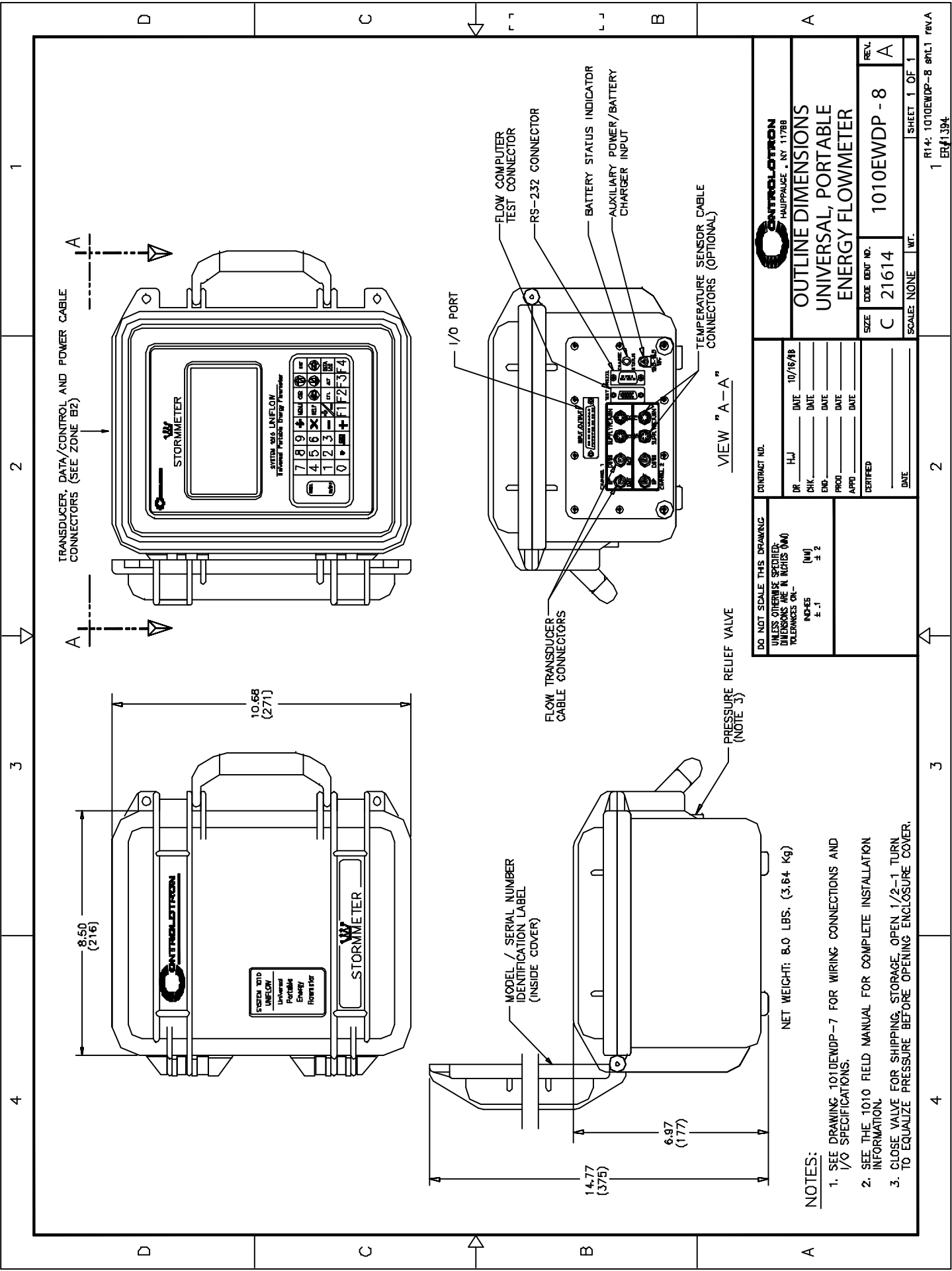

TRANSDUCER, DATA/CONTROL AND POWER CABLE CONNECTORS (SEE ZONE B2)

A ————>

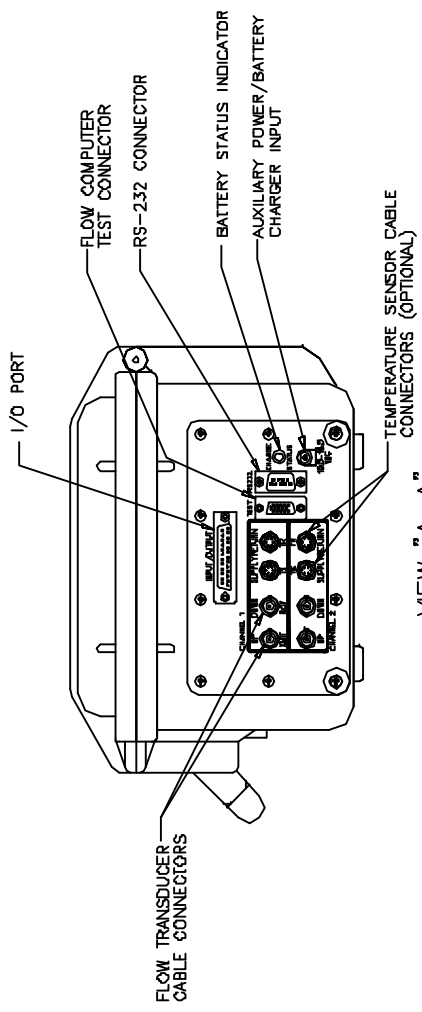
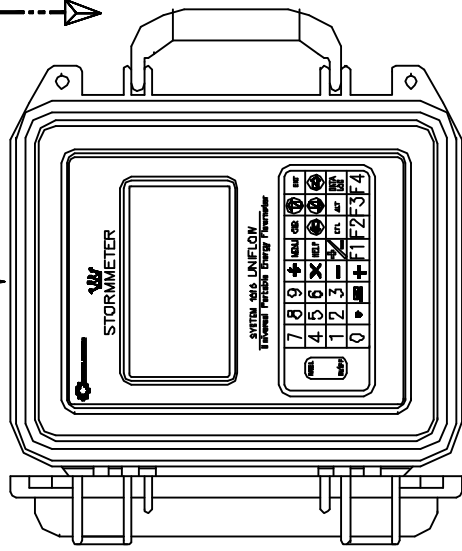

VIEW "A-A"

DO NOT SCALE THIS DRAWING
UNLESS OTHERWISE SPECIFIED
DIMENSIONS ARE IN INCHES (MM)
TOLERANCES ARE:
INCHES ± .1
(MM) ± .2

CONTRACT NO.		DR	H-J	DATE	10/16/08
UNLESS OTHERWISE SPECIFIED DIMENSIONS ARE IN INCHES (MM) TOLERANCES ARE:		CHK		DATE	
		ENG.		DATE	
		PRD.		DATE	
		APP.		DATE	
		CERTIFIED		DATE	

		OUTLINE DIMENSIONS UNIVERSAL, PORTABLE ENERGY FLOWMETER	
SIZE	CODE IDENT. NO.	REV.	A
C	21614	1010EWD-8	
SCALE:	NONE	WT.	
			SHEET 1 OF 1

NOTES:

- SEE DRAWING 1010EWD-7 FOR WIRING CONNECTIONS AND I/O SPECIFICATIONS.
- SEE THE 1010 FIELD MANUAL FOR COMPLETE INSTALLATION INFORMATION.
- CLOSE VALVE FOR SHIPPING, STORAGE. OPEN 1/2-1 TURN TO EQUALIZE PRESSURE BEFORE OPENING ENCLOSURE COVER.

NET WEIGHT: 8.0 LBS. (3.64 Kg)

INSTALLATION PROCEDURE

E-Z CLAMP (WITH ADDITIONAL CHAIN IF REQ'D) ARE USED TO FASTEN TRANSDUCERS TO THE PIPE.

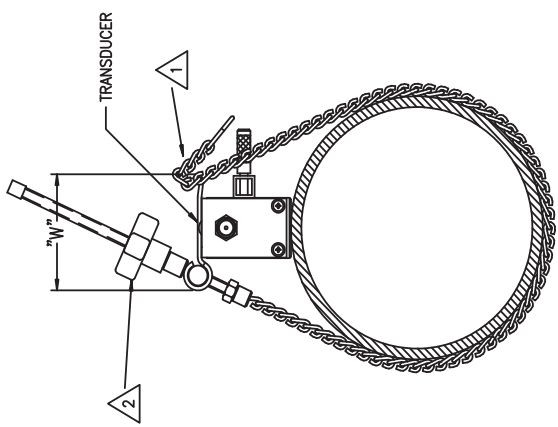

NOTES: (SEE 1010 FIELD MANUAL FOR COMPLETE INSTALLATION INSTRUCTIONS)

1. WRAP THE CHAIN AROUND THE PIPE. PULL TAUT AND ENGAGE A CHAIN LINK WITH THE OPEN HOOK OF THE E-Z CLAMP SUB-ASSY.
2. TIGHTEN THE ADJUSTING NUT TO SECURE THE ASSEMBLY TO THE PIPE.
3. TO SURROUND LARGER PIPES, LINK CHAIN SUB-ASSY SECTIONS TOGETHER BY MATING THE BIT SNAP AND 'S' HOOK AS SHOWN BELOW.

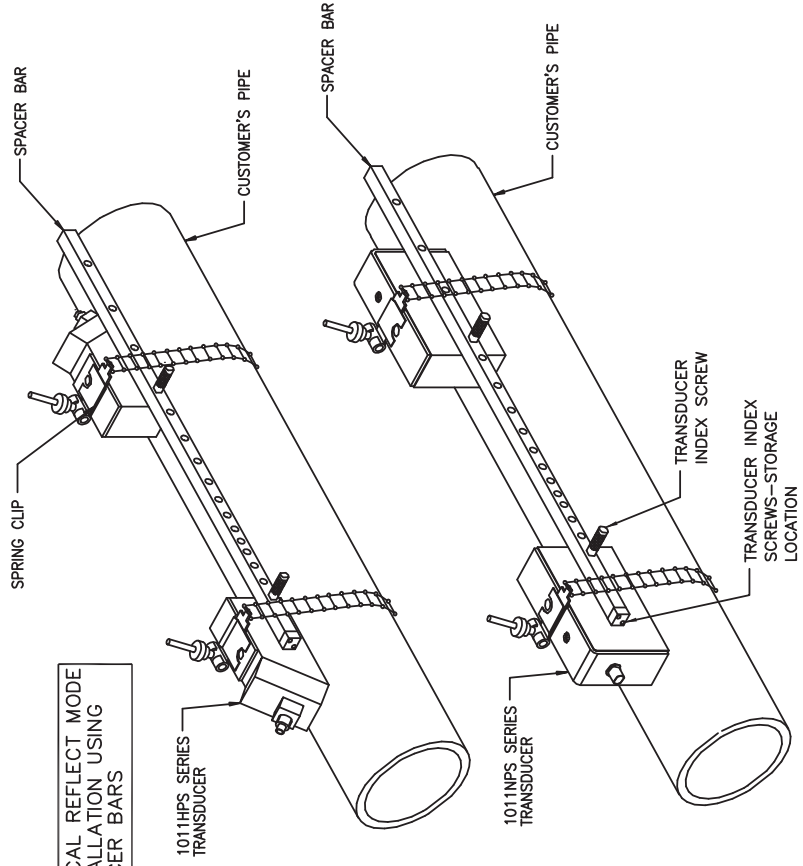
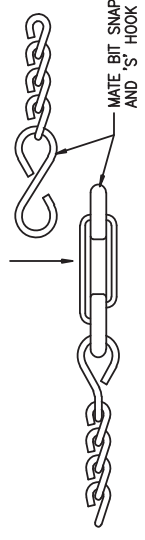

E-Z CLAMP PART NUMBER	CHAIN SECTION P/N / QUANTITY	CHAIN LENGTH	"W"	SPACING GUIDE P/N / DESCRIPTION	KIT NET WT.
1012Z - 1	1012-58-1 / 4	30"	2.52	1012-145-2 / 2" x 81"	1.4 lbs. (0.6 Kg)
1012Z - 2	1012-58-1 / 4	30"	3.12	1012-145-2 / 2" x 81"	1.4 lbs. (0.6 Kg)

EACH E-Z CLAMP KIT CONSISTS OF A PAIR OF CLAMPS WITH INTEGRAL 24" CHAINS. ADDITIONAL CHAIN SECTIONS AS TABULATED ABOVE, AND A SPACING GUIDE (USED FOR DIRECT MODE MOUNTING - SEE INSTRUCTIONS IN THE FIELD MANUAL).

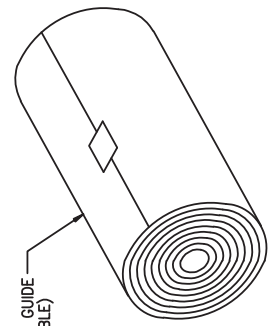

CONTRACT NO.

DR HJJ DATE 6/15/98

CHK _____ DATE _____

ENG _____ DATE _____

PRD _____ DATE _____

APPD _____ DATE _____

CERTIFIED _____

DATE _____

CONTRIBUTOR

INSTALLATION/OUTLINE

E-Z CLAMP MOUNTING KIT

SIZE CODE IDENT NO. **C 21614** REV. **A**

SCALE: NONE WT. 1012Z - 8

SHEET 1 of 1

R14:1012Z-8

1 EN#1369

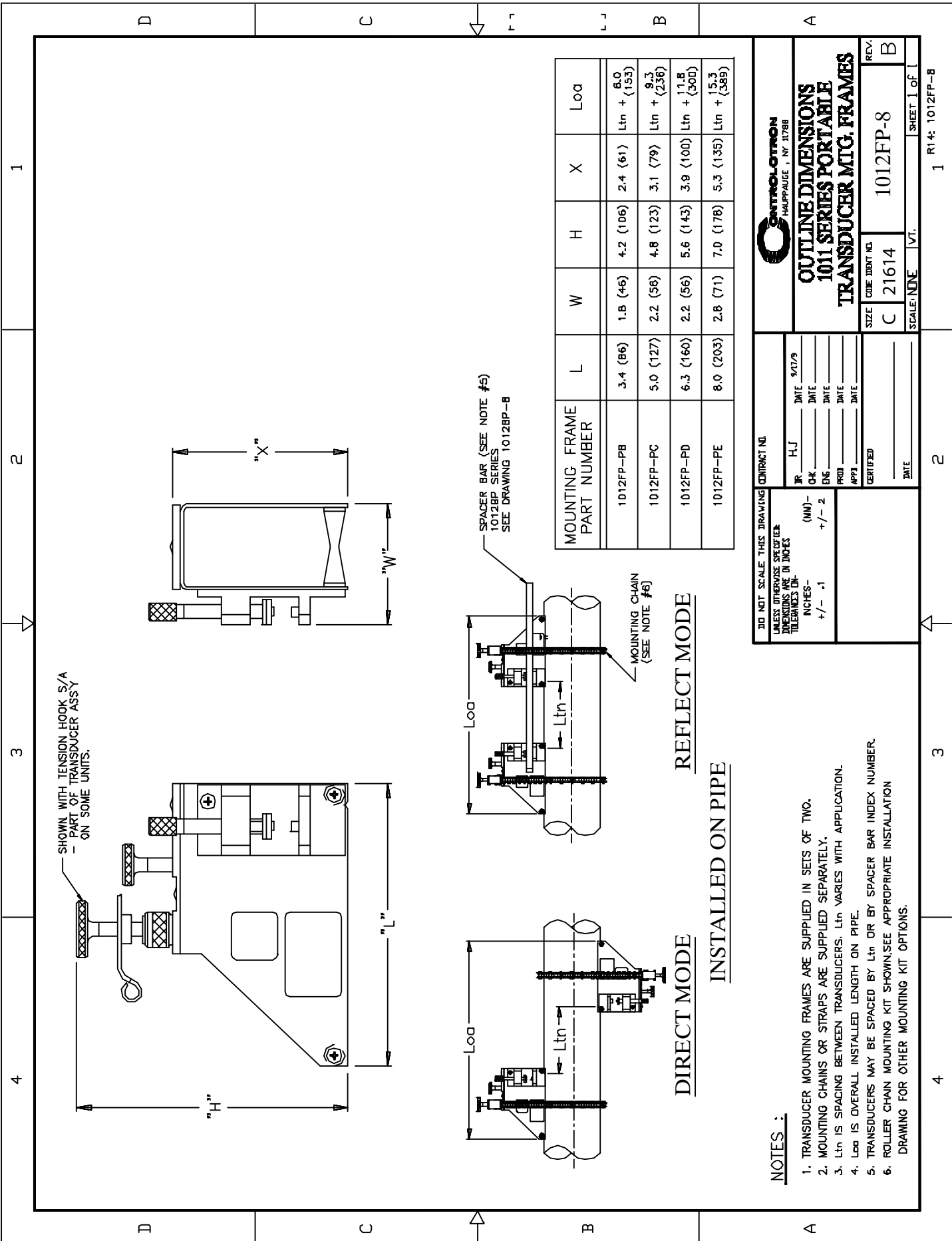

ENTROLOTRON
HALFPAUSE, NY 31788

**OUTLINE DIMENSIONS
1011 SERIES PORTABLE
TRANSDUCER MOUNTING FRAMES**

CONTRACT NO. _____

DATE 9/17/9

INCHES - (MM) -
+/- .01

UNLESS OTHERWISE SPECIFIED,
DIMENSIONS ARE IN INCHES
TOLERANCES ON:

IR _____ DATE _____
CHK _____ DATE _____
ENG _____ DATE _____
PRD _____ DATE _____
APP1 _____ DATE _____

CERTIFIED _____

DATE _____

SCALE: NONE VT. _____

SIZE CODE: JBMT NO. _____
C 21614

REV. _____
B

1012FP-8

SHEET 1 of 1

- NOTES :**
1. TRANSDUCER MOUNTING FRAMES ARE SUPPLIED IN SETS OF TWO.
 2. MOUNTING CHAINS OR STRAPS ARE SUPPLIED SEPARATELY.
 3. Ltn IS SPACING BETWEEN TRANSDUCERS. Ltn VARIES WITH APPLICATION.
 4. Loo IS OVERALL INSTALLED LENGTH ON PIPE.
 5. TRANSDUCERS MAY BE SPACED BY Ltn OR BY SPACER BAR INDEX NUMBER.
 6. ROLLER CHAIN MOUNTING KIT SHOWN. SEE APPROPRIATE INSTALLATION DRAWING FOR OTHER MOUNTING KIT OPTIONS.

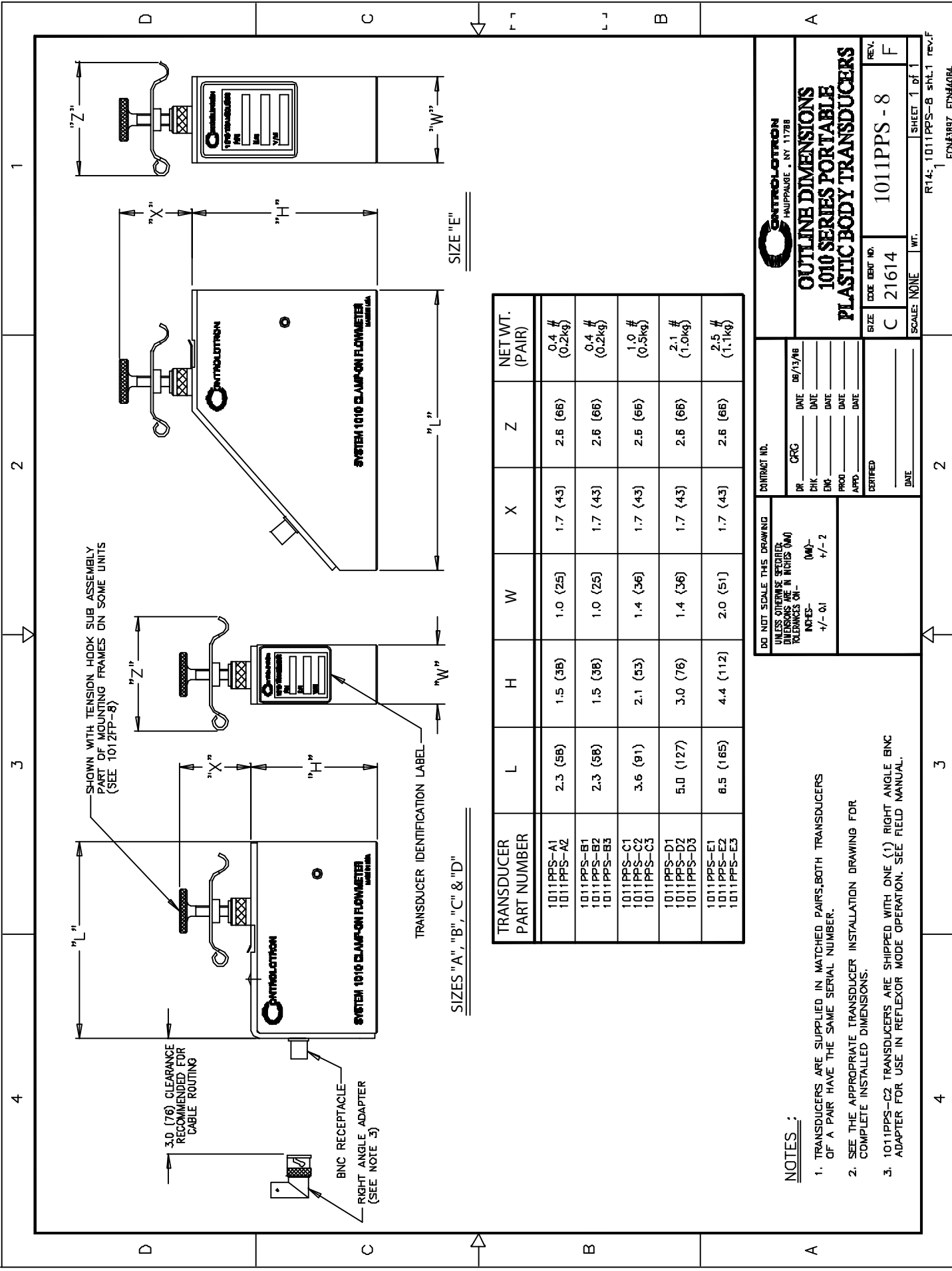

SHOWN WITH TENSION HOOK SUB ASSEMBLY PART OF MOUNTING FRAMES ON SOME UNITS (SEE 1012FP-8)

3.0 (76) CLEARANCE RECOMMENDED FOR CABLE ROUTING

BNC RECEPTACLE
RIGHT ANGLE ADAPTER
(SEE NOTE 3)

TRANSDUCER IDENTIFICATION LABEL

SIZES "A", "B", "C" & "D"

TRANSDUCER PART NUMBER	L	H	W	X	Z	NET WT. (PAIR)
1011PPS-A1 1011PPS-A2	2.3 (58)	1.5 (38)	1.0 (25)	1.7 (43)	2.5 (66)	0.4 # (0.2kg)
1011PPS-B1 1011PPS-B2 1011PPS-B3	2.3 (58)	1.5 (38)	1.0 (25)	1.7 (43)	2.5 (66)	0.4 # (0.2kg)
1011PPS-C1 1011PPS-C2 1011PPS-C3	3.6 (91)	2.1 (53)	1.4 (36)	1.7 (43)	2.5 (66)	1.0 # (0.5kg)
1011PPS-D1 1011PPS-D2 1011PPS-D3	5.0 (127)	3.0 (76)	1.4 (36)	1.7 (43)	2.5 (66)	2.1 # (1.0kg)
1011PPS-E1 1011PPS-E2 1011PPS-E3	6.5 (165)	4.4 (112)	2.0 (51)	1.7 (43)	2.5 (66)	2.5 # (1.1kg)

NOTES:

1. TRANSDUCERS ARE SUPPLIED IN MATCHED PAIRS, BOTH TRANSDUCERS OF A PAIR HAVE THE SAME SERIAL NUMBER.
2. SEE THE APPROPRIATE TRANSDUCER INSTALLATION DRAWING FOR COMPLETE INSTALLED DIMENSIONS.
3. 1011PPS-C2 TRANSDUCERS ARE SHIPPED WITH ONE (1) RIGHT ANGLE BNC ADAPTER FOR USE IN REFLEXOR MODE OPERATION. SEE FIELD MANUAL.

CONTROLTRON
HAUPPAUGE, NY 11788

OUTLINE DIMENSIONS
1010 SERIES PORTABLE
PLASTIC BODY TRANSDUCERS

DR	CRG	DATE	06/13/86
CHK	ENG	DATE	
PROJ	APPR	DATE	
CERTIFIED	DATE		

CONTRACT NO. _____

DO NOT SCALE THIS DRAWING
UNLESS OTHERWISE SPECIFIED
DIMENSIONS ARE IN INCHES (MM)
TOLERANCES ON -
INCHES - (MM) -
+/- .01 +/- .2

SIZE	CODE DEV. NO.	REV.
C	21614	F

SCALE: NONE WT. SHEET 1 of 1

R14: 1011PPS-8 sht.1 rev.F
1
EDN43897, EDN44094

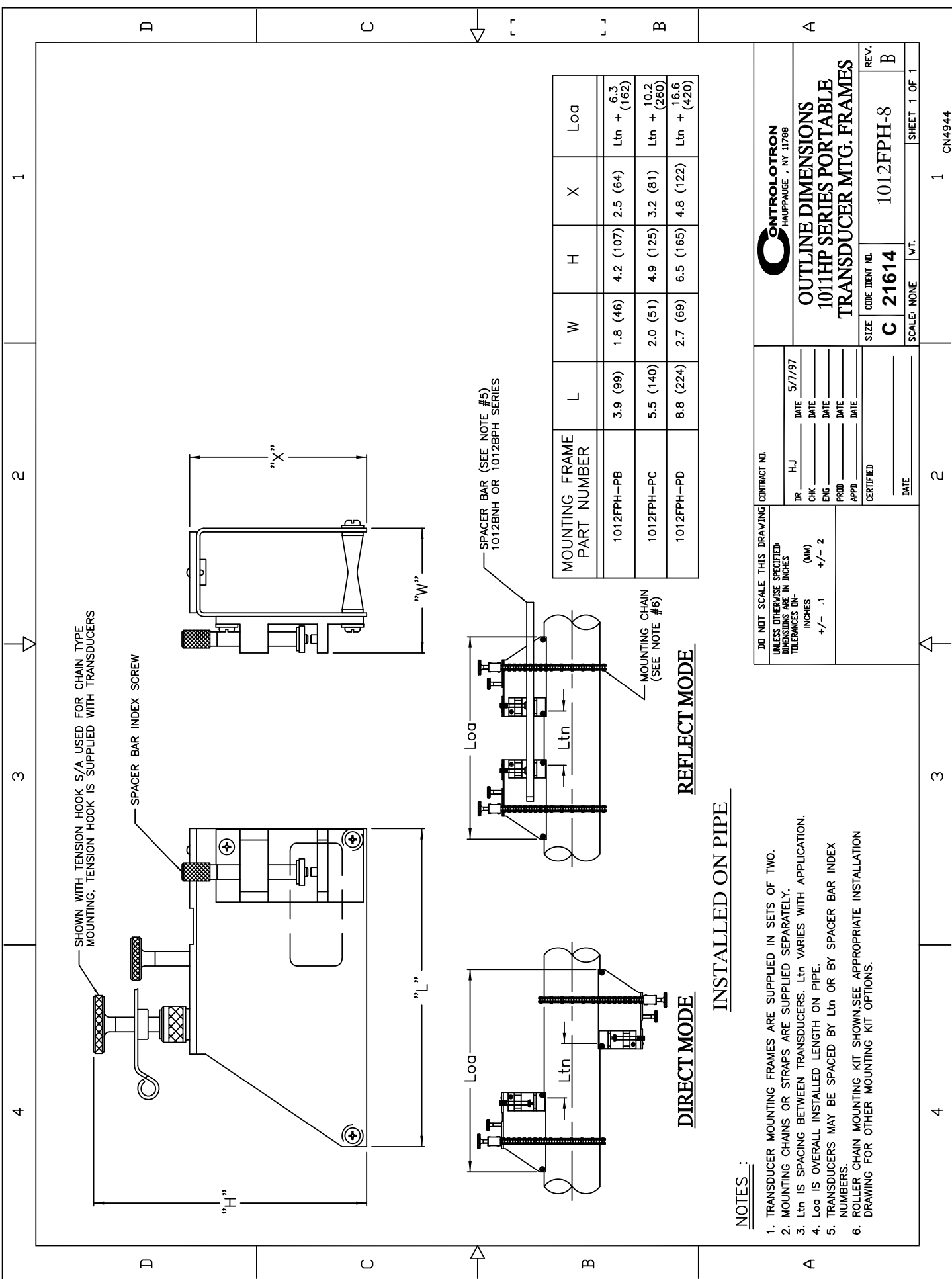

MOUNTING FRAME PART NUMBER	L	W	H	X	Load
1012FPH-PB	3.9 (99)	1.8 (46)	4.2 (107)	2.5 (64)	Ltn + 6.3 (162)
1012FPH-PC	5.5 (140)	2.0 (51)	4.9 (125)	3.2 (81)	Ltn + 10.2 (260)
1012FPH-PD	8.8 (224)	2.7 (69)	6.5 (165)	4.8 (122)	Ltn + 16.6 (420)

NOTES:

- INSTALLED ON PIPE
1. TRANSDUCER MOUNTING FRAMES ARE SUPPLIED IN SETS OF TWO.
 2. MOUNTING CHAINS OR STRAPS ARE SUPPLIED SEPARATELY.
 3. Ltn IS SPACING BETWEEN TRANSDUCERS. Ltn VARIES WITH APPLICATION.
 4. Loo IS OVERALL INSTALLED LENGTH ON PIPE.
 5. TRANSDUCERS MAY BE SPACED BY Ltn OR BY SPACER BAR INDEX NUMBERS.
 6. ROLLER CHAIN MOUNTING KIT SHOWN. SEE APPROPRIATE INSTALLATION DRAWING FOR OTHER MOUNTING KIT OPTIONS.

DO NOT SCALE THIS DRAWING CONTRACT NO. _____

UNLESS OTHERWISE SPECIFIED DIMENSIONS ARE IN INCHES TOLERANCES UNLESS OTHERWISE SPECIFIED

INCHES (MM) +/- .1 +/- .2

DATE 5/7/97

DR. H.J. DATE _____

CHK. DATE _____

ENG. DATE _____

PRD. DATE _____

APPD. DATE _____

CERTIFIED _____

CONTROLTRON
HAUPPAUGE, NY 11788

OUTLINE DIMENSIONS
1011HP SERIES PORTABLE
TRANSDUCER MTG. FRAMES

SIZE CODE IDENT. NO. **C 21614** REV. **B**

SCALE: NONE W.T. 1012FPH-8 SHEET 1 OF 1

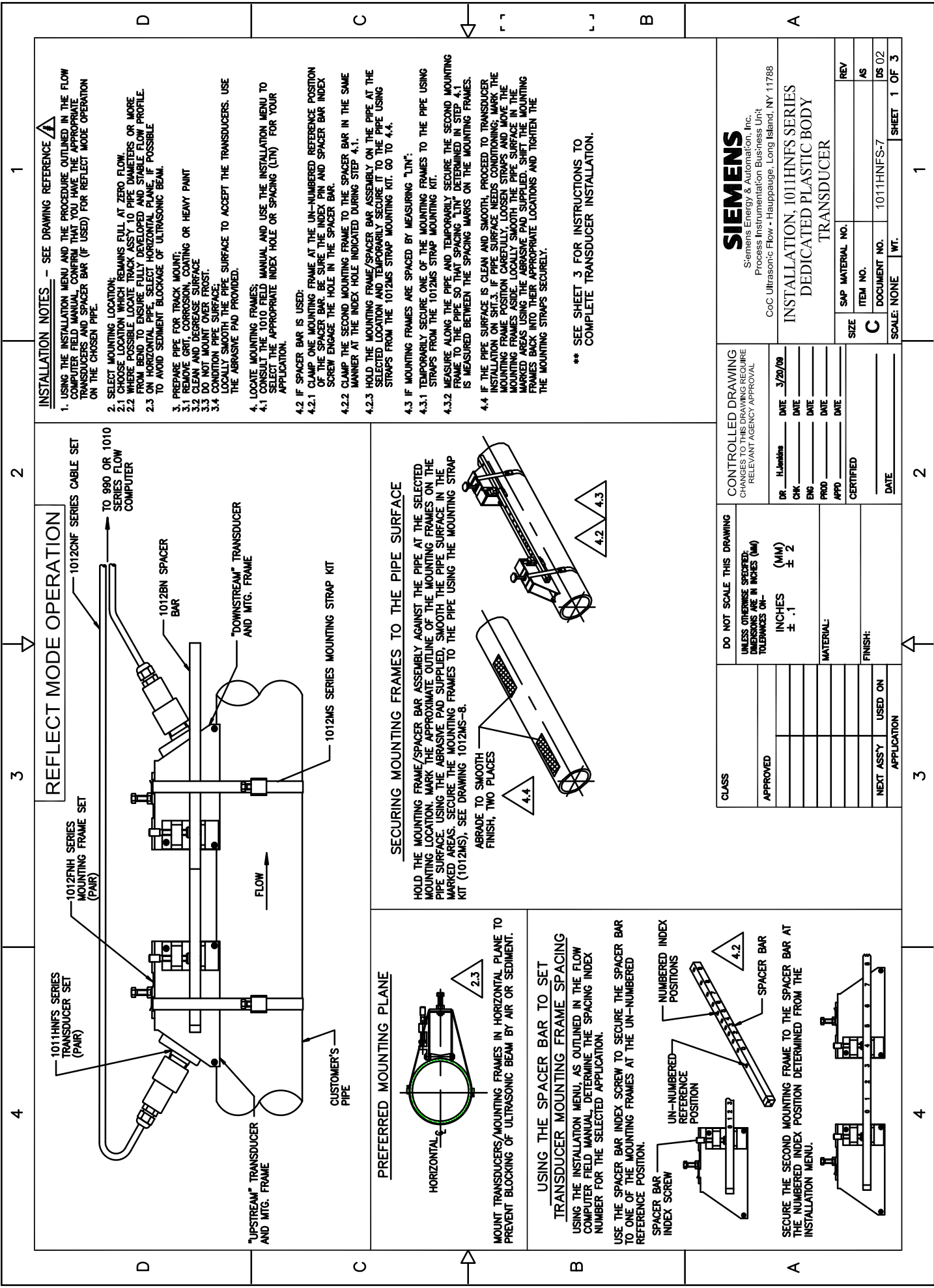

REFLECT MODE OPERATION

- INSTALLATION NOTES** - SEE DRAWING REFERENCE **A**
- USING THE INSTALLATION MENU AND THE PROCEDURE OUTLINED IN THE FLOW COMPUTER FIELD MANUAL, CONFIRM THAT YOU HAVE THE APPROPRIATE TRANSDUCERS AND SPACER BAR (IF USED) FOR REFLECT MODE OPERATION ON THE CHOSEN PIPE.
 - SELECT MOUNTING LOCATION;
 - CHOOSE LOCATION WHICH REMAINS FULL AT ZERO FLOW.
 - WHERE POSSIBLE LOCATE TRACK ASSY TO PIPE DIAMETERS OR MORE FROM BEND TO ENSURE FULLY DEVELOPED AND STABLE FLOW PROFILE.
 - ON HORIZONTAL PIPE, SELECT HORIZONTAL PLANE. IF POSSIBLE TO AVOID SEDIMENT BLOCKAGE OF ULTRASONIC BEAM.
 - PREPARE PIPE FOR TRACK MOUNT;
 - REMOVE GRIT, CORROSION, COATING OR HEAVY PAINT
 - CLEAN AND DEGREASE SURFACE
 - DO NOT MOUNT OVER FROST.
 - CONDITION PIPE SURFACE.
 - LOCALLY SMOOTH THE PIPE SURFACE TO ACCEPT THE TRANSDUCERS. USE THE ABRASIVE PAD PROVIDED.
 - LOCATE MOUNTING FRAMES;
 - CONSULT THE 1010 FIELD MANUAL, AND USE THE INSTALLATION MENU TO SELECT THE APPROPRIATE INDEX HOLE OR SPACING (LIN) FOR YOUR APPLICATION.
 - IF SPACER BAR IS USED:
 - CLAMP ONE MOUNTING FRAME AT THE UN-NUMBERED REFERENCE POSITION OF THE SPACER BAR. BE SURE THE INDEX PIN AND SPACER BAR INDEX SCREW ENGAGE THE HOLE IN THE SPACER BAR.
 - CLAMP THE SECOND MOUNTING FRAME TO THE SPACER BAR IN THE SAME MANNER AT THE INDEX HOLE INDICATED DURING STEP 4.1.
 - HOLD THE MOUNTING FRAME/SPACER BAR ASSEMBLY ON THE PIPE AT THE SELECTED LOCATION AND TEMPORARILY SECURE IT TO THE PIPE USING STRAPS FROM THE 1012MS STRAP MOUNTING KIT. GO TO 4.4.
 - IF MOUNTING FRAMES ARE SPACED BY MEASURING "LIN":
 - TEMPORARILY SECURE ONE OF THE MOUNTING FRAMES TO THE PIPE USING STRAPS FROM THE 1012MS STRAP MOUNTING KIT.
 - MEASURE ALONG THE PIPE AND TEMPORARILY SECURE THE SECOND MOUNTING FRAME TO THE PIPE SO THAT SPACING "LIN" DETERMINED IN STEP 4.1 IS MEASURED BETWEEN THE SPACING MARKS ON THE MOUNTING FRAMES.
 - IF THE PIPE SURFACE IS CLEAN AND SMOOTH, PROCEED TO TRANSDUCER INSTALLATION ON SHT.3. IF PIPE SURFACE NEEDS CONDITIONING; MARK THE MOUNTING FRAME POSITION CAREFULLY, LOOSEN STRAPS AND MOVE THE MOUNTING FRAMES ASIDE. LOCALLY SMOOTH THE PIPE SURFACE IN THE MARKED AREAS USING THE ABRASIVE PAD SUPPLIED. SHIFT THE MOUNTING FRAMES BACK INTO THEIR APPROPRIATE LOCATIONS AND TIGHTEN THE MOUNTING STRAPS SECURELY.

SECURING MOUNTING FRAMES TO THE PIPE SURFACE

HOLD THE MOUNTING FRAME/SPACER BAR ASSEMBLY AGAINST THE PIPE AT THE SELECTED MOUNTING LOCATION. MARK THE APPROXIMATE OUTLINE OF THE MOUNTING FRAMES ON THE PIPE SURFACE. USING THE ABRASIVE PAD SUPPLIED, SMOOTH THE PIPE SURFACE IN THE MARKED AREAS. SECURE THE MOUNTING FRAMES TO THE PIPE USING THE MOUNTING STRAP KIT (1012MS). SEE DRAWING 1012MS-8.

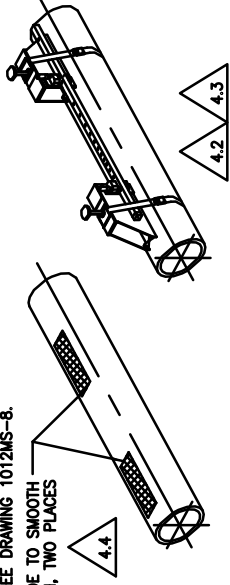

PREFERRED MOUNTING PLANE

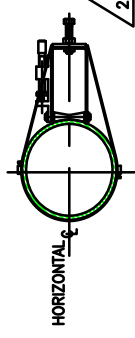

MOUNT TRANSDUCERS/MOUNTING FRAMES IN HORIZONTAL PLANE TO PREVENT BLOCKING OF ULTRASONIC BEAM BY AIR OR SEDIMENT.

USING THE SPACER BAR TO SET TRANSDUCER MOUNTING FRAME SPACING

USING THE INSTALLATION MENU, AS OUTLINED IN THE FLOW COMPUTER FIELD MANUAL, DETERMINE THE SPACING INDEX NUMBER FOR THE SELECTED APPLICATION.

USE THE SPACER BAR INDEX SCREW TO SECURE THE SPACER BAR TO ONE OF THE MOUNTING FRAMES AT THE UN-NUMBERED REFERENCE POSITION.

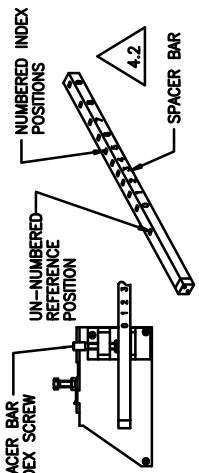

SECURE THE SECOND MOUNTING FRAME TO THE SPACER BAR AT THE NUMBERED INDEX POSITION DETERMINED FROM THE INSTALLATION MENU.

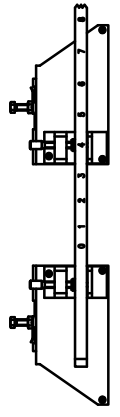

** SEE SHEET 3 FOR INSTRUCTIONS TO COMPLETE TRANSDUCER INSTALLATION.

CLASS	DO NOT SCALE THIS DRAWING		CONTROLLED DRAWING	
	UNLESS OTHERWISE SPECIFIED: DIMENSIONS ARE IN INCHES (MM) TOLERANCES ON-		CHANGES TO THIS DRAWING REQUIRE RELEVANT AGENCY APPROVAL	
APPROVED	INCHES ± .1	DATE 3/20/09	DR H. J. ...	DATE
	(MM) ± .2	DATE	CHK	DATE
	MATERIAL:	DATE	ENG	DATE
	FINISH:	DATE	APPD	DATE
NEXT ASSY USED ON		CERTIFIED		
APPLICATION		DATE		

SIEMENS
Siemens Energy & Automation, Inc.
Process Instrumentation Business Unit
CoC Ultrasonic Flow - Heppauge, Long Island, NY 11788

INSTALLATION, 1011HNF5 SERIES DEDICATED PLASTIC BODY TRANSDUCER

SIZE	SAP MATERIAL NO.	REV
C	ITEM NO.	AS
SCALE: NONE	DOCUMENT NO. 1011HNF5-7	DS 02
	WT.	SHEET 1 OF 3

PREFERRED MOUNTING PLANE

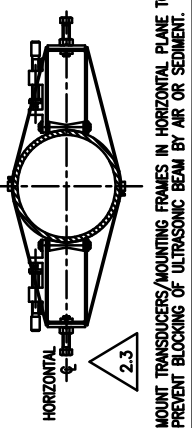

USING THE SPACER BAR TO SET TRANSDUCER MOUNTING FRAME SPACING

USING THE INSTALLATION MENU AND THE PROCEDURE OUTLINED IN THE FLOW COMPUTER FIELD MANUAL, DETERMINE THE SPACING INDEX NUMBER FOR THE SELECTED APPLICATION. USE THE SPACER BAR INDEX SCREW TO SECURE THE SPACER BAR TO ONE OF THE MOUNTING FRAMES AT THE UN-NUMBERED REFERENCE POSITION.

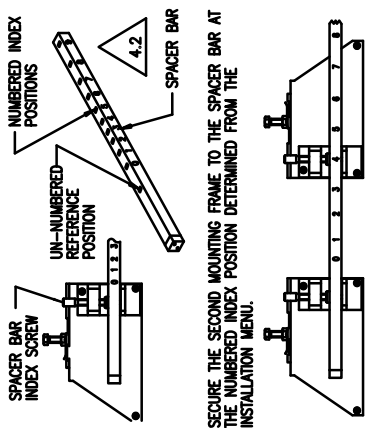

WRAP MOUNTING GUIDE AROUND PIPE AND MARK AT OVERLAPPING EDGE. UNWRAP GUIDE, MEASURE DISTANCE 1/2" FROM EDGE TO MARK. TAP AGAIN AT 1/2". RE-INSTALL THE MOUNTING GUIDE. TAPE IN PLACE WITH BOTH MARKS VISIBLE. ALIGN ONE MARK WITH THE CENTER LINE OF THE MOUNTING FRAMES.

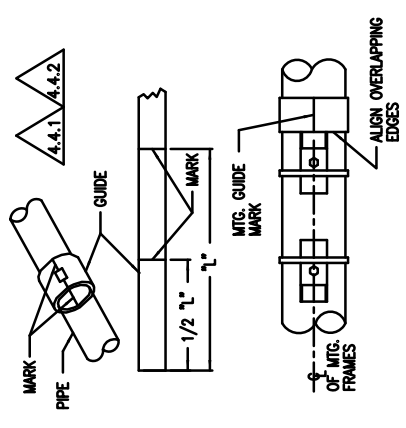

DIRECT MODE OPERATION

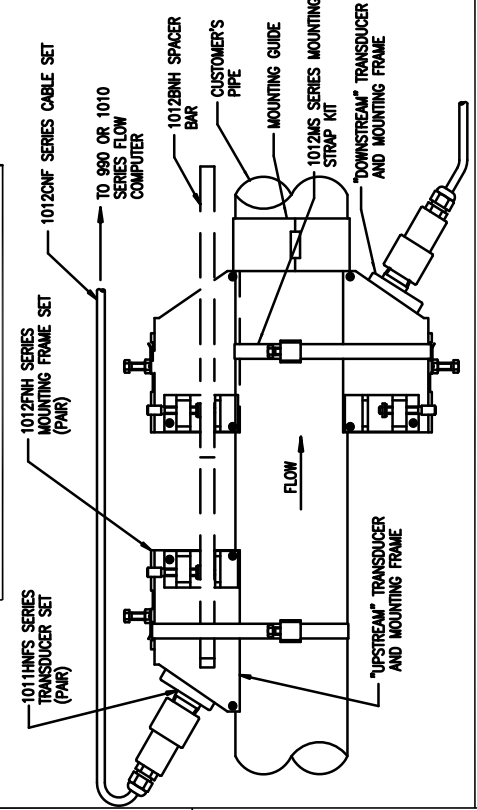

SECURING MOUNTING FRAMES TO THE PIPE SURFACE

HOLD THE MOUNTING FRAME/SPACER BAR ASSEMBLY AGAINST THE PIPE AT THE SELECTED MOUNTING LOCATION OR POSITION USING LTN, TEMPORARILY STRAP IN PLACE.

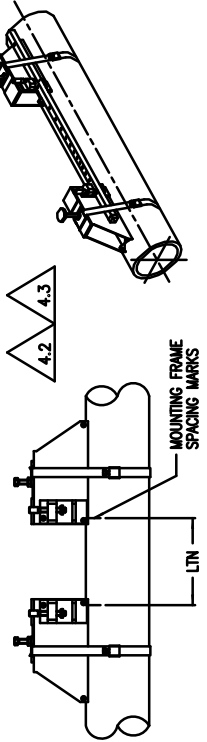

USE THE MOUNTING GUIDE TO TRANSFER ONE OF THE MOUNTING FRAMES TO THE OPPOSITE SIDE OF THE PIPE.

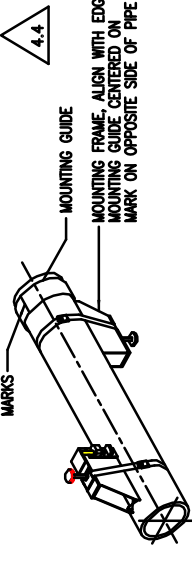

IF NECESSARY, USE THE ABRASIVE PAD SUPPLIED TO PRODUCE A SMOOTH FINISH ON THE PIPE AT THE TRANSDUCER MOUNTING POSITIONS.

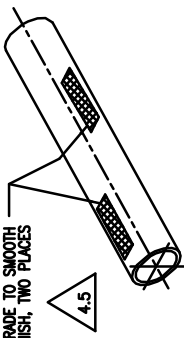

INSTALLATION NOTES - SEE DRAWING REFERENCE.

1. USING THE INSTALLATION MENU AND THE PROCEDURE OUTLINED IN THE FLOW COMPUTER FIELD MANUAL, CONFIRM THAT YOU HAVE THE APPROPRIATE TRANSDUCERS AND SPACER BAR (IF USED) FOR DIRECT MODE OPERATION ON THE CHOSEN PIPE.
 - 2.1 SELECT MOUNTING LOCATION;
 - 2.2 WHERE POSSIBLE, LOCATE TRACK ASSY TO PIPE DIAMETERS OR MORE FROM BEND TO ENSURE FULLY DEVELOPED AND STABLE FLOW PROFILE ON HORIZONTAL PIPE TO SELECT HORIZONTAL PLANE, IF POSSIBLE;
 - 2.3 PREPARE PIPE FOR TRACK MOUNT;
 - 3.1 REMOVE GENTLE CORROSION COATING OR HEAVY PAINT;
 - 3.2 CLEAN AND DEGREASE SURFACE;
 - 3.3 DO NOT MOUNT OVER FROST;
 - 3.4 CONDITION PIPE SURFACE;
 - 4.1 LOCALLY SMOOTH THE PIPE SURFACE TO ACCEPT THE TRANSDUCERS. USE THE ABRASIVE PAD PROVIDED.
 - 4.2 LOCATE MOUNTING FRAMES;
 - 4.3 CONSULT THE 1010 FIELD MANUAL AND USE THE INSTALLATION MENU TO SELECT THE APPROPRIATE INDEX HOLE OR SPACING (LTN) FOR YOUR APPLICATION.
 - 4.2 IF SPACER BAR IS USED:
 - 4.2.1 CLAMP ONE MOUNTING FRAME AT THE UN-NUMBERED REFERENCE POSITION OF THE SPACER BAR. BE SURE THE INDEX PIN AND SPACER BAR INDEX SCREW ENGAGE THE HOLE IN THE SPACER BAR.
 - 4.2.2 CLAMP THE SECOND MOUNTING FRAME TO THE SPACER BAR IN THE SAME MANNER AT THE INDEX HOLE INDICATED DURING STEP 4.1.
 - 4.2.3 HOLD THE MOUNTING FRAME/SPACER BAR ASSEMBLY ON THE PIPE AT THE SELECTED LOCATION AND TEMPORARILY SECURE IT TO THE PIPE USING STRAPS FROM THE 1012MS STRAP MOUNTING KIT. GO TO 4.4.
 - 4.3 IF MOUNTING FRAMES ARE SPACED BY MEASURING "L":
 - 4.3.1 TEMPORARILY SECURE ONE OF THE MOUNTING FRAMES TO THE PIPE USING STRAPS FROM THE 1012MS STRAP MOUNTING KIT.
 - 4.3.2 MEASURE ALONG THE PIPE AND TEMPORARILY SECURE THE SECOND MOUNTING FRAME TO THE PIPE USING STRAPS FROM THE 1012MS STRAP MOUNTING KIT. MEASURE THE DISTANCE BETWEEN THE SPACING MARKS ON THE MOUNTING FRAMES. USE A STRAIGHT EDGE OR OTHER MEANS TO ALIGN BOTH MOUNTING FRAMES WITH PIPE AXIS.
 - 4.4 USE THE MOUNTING GUIDE INCLUDED WITH THE 1012MS STRAP MOUNTING KIT TO TRANSFER ONE OF THE MOUNTING FRAMES TO THE OPPOSITE SIDE OF THE PIPE.
 - 4.4.1 WRAP THE MOUNTING GUIDE AROUND THE PIPE. POSITION IT SO THAT THE OVERLAPPING EDGES ARE EDGE-ALIGNED. MARK THE OVERLAPPING PORTION OF THE GUIDE AT THE EDGE OF THE OVERLAPPING PORTION. REMOVE THE GUIDE. MEASURE THE DISTANCE FROM THE END TO THE MARK AND MARK AGAIN HALFWAY BETWEEN.
 - 4.4.2 RE-POSITION THE GUIDE ON THE PIPE AND TAPE IN PLACE SO THAT ONE OF THE MARKS INDICATES THE CENTERLINE OF THE INSTALLED MOUNTING FRAMES AND THE MOUNTING GUIDE EDGE IS AGAINST THE END OF ONE OF THE MOUNTING FRAMES. MAKE SURE THE OVERLAPPING LENGTHS OF THE MOUNTING GUIDE ARE EDGE-ALIGNED. THIS ASSURES A DIAMETRICAL TRANSFER OF THE MOUNTING FRAME POSITION.
 - 4.4.3 LOOSEN THE MOUNTING STRAP ON THE MOUNTING FRAME WITH WHICH THE MOUNTING GUIDE HAS BEEN ALIGNED. ROTATE IT AROUND THE PIPE SURFACE UNTIL IT IS CENTERED ON THE OPPOSITE SIDE MOUNTING GUIDE. MARK MADE IN STEP 4.4.1. TIGHTEN THE STRAP. REMOVE THE MOUNTING GUIDE.
 - 4.5 IF THE PIPE SURFACE IS CLEAN AND SMOOTH, PROCEED TO TRANSDUCER INSTALLATION ON SH-3. IF PIPE SURFACE NEEDS CONDITIONING, MARK THE MOUNTING FRAME POSITION CAREFULLY, LOOSEN STRAPS AND MOVE THE MOUNTING FRAMES ASIDE. LOCALLY SMOOTH THE PIPE SURFACE IN THE MARKED AREAS USING THE ABRASIVE PAD SUPPLIED. SHIFT THE MOUNTING FRAMES BACK INTO THEIR APPROPRIATE LOCATIONS AND TIGHTEN THE MOUNTING STRAPS SECURELY. ** SEE SHEET 3 FOR INSTRUCTIONS TO COMPLETE TRANSDUCER INSTALLATION.

CONTROLLED DRAWING
CHANGES TO THIS DRAWING REQUIRE RELEVANT AGENCY APPROVAL

DR	H.Jenkins	DATE	3/20/09
CHK		DATE	
ENG		DATE	
APPD		DATE	
CERTIFIED			
DATE			

DO NOT SCALE THIS DRAWING
UNLESS OTHERWISE SPECIFIED, DIMENSIONS ARE IN INCHES (MM) TOLERANCES ON-

INCHES	± .1	(MM)	± .2
MATERIAL:			
FINISH:			

SIEMENS
Siemens Energy & Automation, Inc.
Process Instrumentation Business Unit
CoC Ultrasonic Flow - Hauppauge, Long Island, NY 11788

INSTALLATION, 1011HNS SERIES DEDICATED PLASTIC BODY TRANSDUCER

SAP MATERIAL NO.	REV
ITEM NO.	AS
DOCUMENT NO.	1011HNS-7
SCALE: NONE	WT.
	SHEET 2 OF 3

MATING 1012CNF SERIES TRANSDUCER CABLES WITH 1011HNF SERIES TRANSDUCERS

- d) REMOVE PROTECTIVE CAPS.
- b) SEE APPROPRIATE CABLE ASSEMBLY DRAWING FOR 'F' CONNECTOR, NPT ADAPTER AND GLAND ASSEMBLY DETAIL.
- c) MATE 'F' CONNECTORS, CABLES TO TRANSDUCER.
- d) FOR BEST WEATHER SEAL, WRAP TEFLON PIPE TAPE (NOT SUPPLIED) AROUND MALE NPT THREADS ON TRANSDUCER HOUSING.
- e) SCREW NPT ADAPTER TO TRANSDUCER HOUSING (HAND TIGHT IS SUFFICIENT).
- f) TIGHTEN GLAND BODY, WITH NPT ADAPTER AND SECURE CABLE BY TIGHTENING GLAND TOP NUT. (HAND TIGHT IS SUFFICIENT).

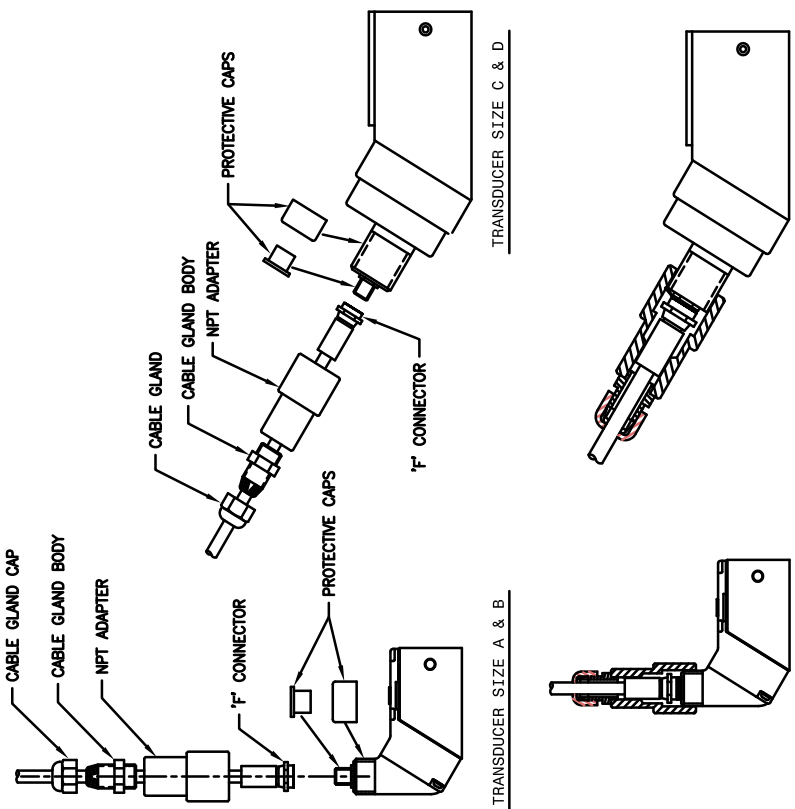

INSTALLING TRANSDUCERS IN MOUNTING FRAMES

APPLY A THIN BAND OF COUPLANT TO THE EMITTING SURFACE OF THE TRANSDUCERS. SLIP THE TRANSDUCERS INTO THE MOUNTING FRAMES, SEATING THEM SQUARELY ON THE PIPE SURFACE. PUSH FORWARD INTO THE FRAMES AGAINST THE FRONT SPACER. LOCATE CLAMPING SCREW IN PROPER POSITION. TIGHTEN THE TRANSDUCER CLAMPING SCREW, FIRMLY SEATING THE TRANSDUCERS ON THE PIPE SURFACE. SECURE THE CLAMPING SCREW WITH LOCK NUT.

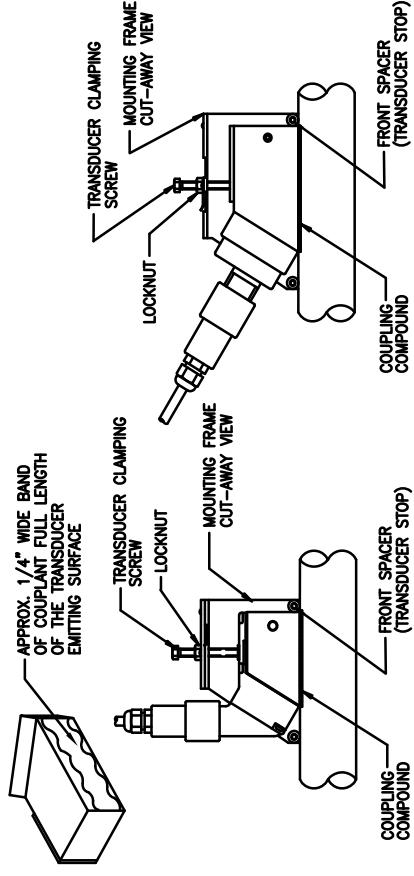

**SEE DRAWING 1012THP-7 FOR INSTALLATION USING 1012THP SERIES MOUNTING TRACKS.

USE OF FLEXIBLE CONDUIT WITH TRANSDUCERS

THE TRANSDUCER WIRING HOUSING HAS INTEGRAL 1/2" N.P.T. THREADS TO ACCEPT A CONDUIT COUPLING IF FLEXIBLE CONDUIT IS USED. MAKE CONNECTION AS SHOWN, THEN PASS COUPLING AND CONDUIT OVER THE CABLE, SECURE TO THE TRANSDUCER WIRING HOUSING.

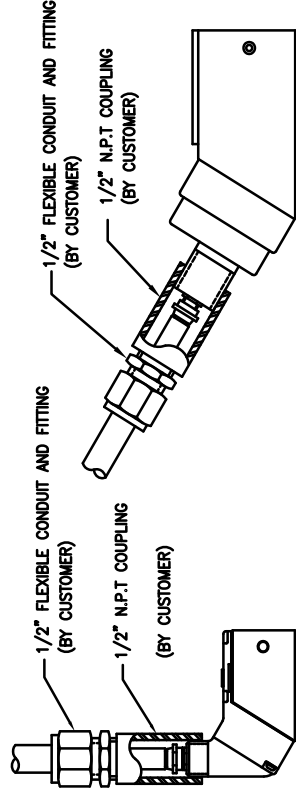

INSTALLATION NOTES

- 5. MAKE CABLE CONNECTIONS AT FLOW COMPUTER IN ACCORDANCE WITH APPROPRIATE FLOW COMPUTER INSTALLATION DRAWING AND 1010 FIELD MANUAL.
- 6. SEE DRAWINGS 1012FNH-B AND 1011HNF-B FOR MOUNTING FRAME AND TRANSDUCER OUTLINE DIMENSIONS.

DO NOT SCALE THIS DRAWING
UNLESS OTHERWISE SPECIFIED:
DIMENSIONS ARE IN INCHES (MM)
TOLERANCES ON-

INCHES (MM)
± .1 (MM) ± .2

MATERIAL:

FINISH:

CONTROLLED DRAWING
CHANGES TO THIS DRAWING REQUIRE
RELEVANT AGENCY APPROVAL

DR	H. J. J. J.	DATE	5/20/09
CHK		DATE	
ENG		DATE	
PRD		DATE	
APPD		DATE	
CERTIFIED			
DATE			

SIEMENS
Siemens Energy & Automation, Inc.
Process Instrumentation Business Unit
CoC Ultrasonic Flow - Hauppauge, Long Island, NY 11788

INSTALLATION, 1011HNF SERIES
DEDICATED PLASTIC BODY
TRANSDUCER

SIZE	SAP MATERIAL NO.	REV
C	ITEM NO.	AS
DOCUMENT NO.	1011HNF-7	DS 02
SCALE: NONE	WT.	SHEET 3 OF 3

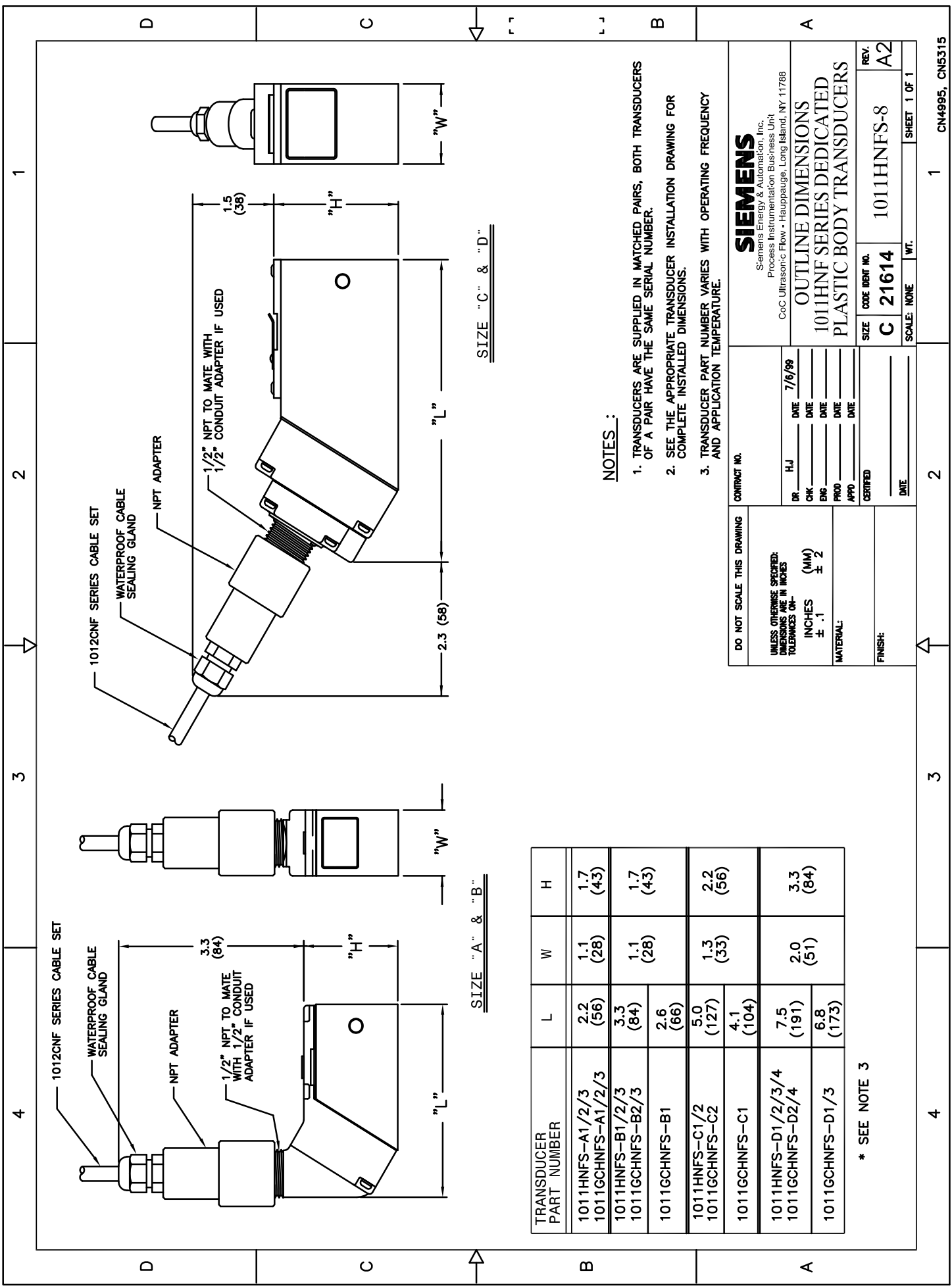

SIZE "C" & "D"

SIZE "A" & "B"

NOTES :

1. TRANSDUCERS ARE SUPPLIED IN MATCHED PAIRS, BOTH TRANSDUCERS OF A PAIR HAVE THE SAME SERIAL NUMBER.
2. SEE THE APPROPRIATE TRANSDUCER INSTALLATION DRAWING FOR COMPLETE INSTALLED DIMENSIONS.
3. TRANSDUCER PART NUMBER VARIES WITH OPERATING FREQUENCY AND APPLICATION TEMPERATURE.

TRANSUCER PART NUMBER	L	W	H
1011HNFS-A1/2/3	2.2 (56)	1.1 (28)	1.7 (43)
1011GCHNFS-A1/2/3	3.3 (84)	1.1 (28)	1.7 (43)
1011HNFS-B1/2/3	2.6 (66)	1.3 (33)	2.2 (56)
1011GCHNFS-B1/2/3	5.0 (127)	2.0 (51)	3.3 (84)
1011GCHNFS-C1	4.1 (104)	6.8 (173)	

* SEE NOTE 3

SIEMENS
Siemens Energy & Automation, Inc.
Process Instrumentation Business Unit
CoC Ultrasonic Flow - Hauptpage, Long Island, NY 11788

OUTLINE DIMENSIONS
1011HNF SERIES DEDICATED
PLASTIC BODY TRANSDUCERS

DO NOT SCALE THIS DRAWING

UNLESS OTHERWISE SPECIFIED:
DIMENSIONS ARE IN INCHES
TOLERANCES ON-

INCHES ± .1 (MM) ± .2

MATERIAL:

FINISH:

CONTRACT NO.

DR HJJ DATE 7/6/99

CHK DATE

ENG DATE

PROD DATE

APPO DATE

CERTIFIED

DATE

SCALE: NONE

WT.

REV. A2

1011HNFS-8

SIZE CODE IDENT NO. C 21614

SHEET 1 OF 1

4

3

2

1

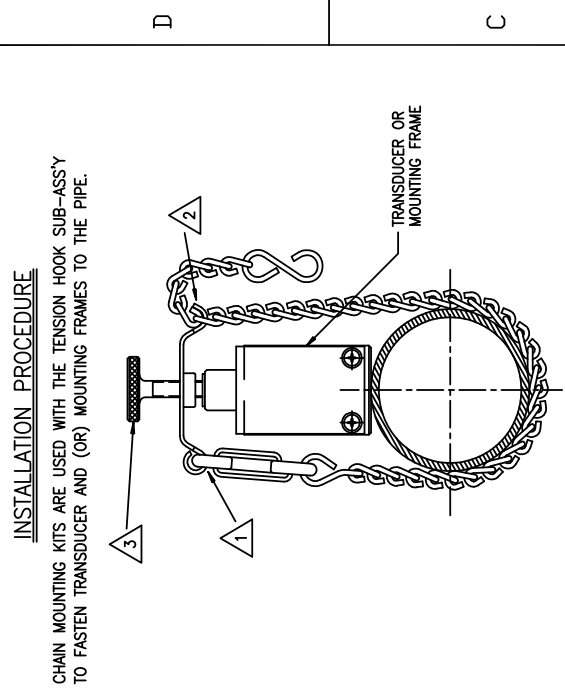
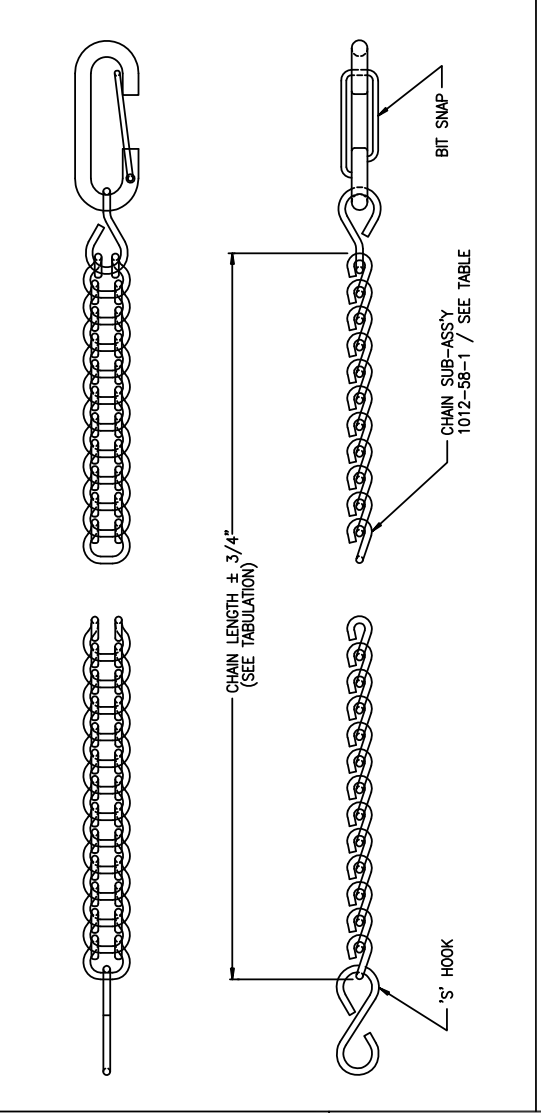

INSTALLATION PROCEDURE

CHAIN MOUNTING KITS ARE USED WITH THE TENSION HOOK SUB-ASS'Y TO FASTEN TRANSDUCER AND (OR) MOUNTING FRAMES TO THE PIPE.

NOTES:

1. CONNECT THE CHAIN BIT SNAP TO THE CLOSED LOOP ON THE TENSION HOOK SUB-ASS'Y.
2. WRAP THE CHAIN AROUND THE PIPE, PULL TIGHT AND ENGAGE A CHAIN LINK WITH THE OPEN HOOK OF THE TENSION HOOK SUB-ASS'Y.
3. TIGHTEN THE ADJUSTING SCREW TO SECURE THE ASSEMBLY TO THE PIPE.
4. TO SURROUND LARGER PIPES, LINK CHAIN SUB-ASS'Y SECTIONS TOGETHER BY MATING THE BIT SNAP AND 'S' HOOK AS SHOWN BELOW.

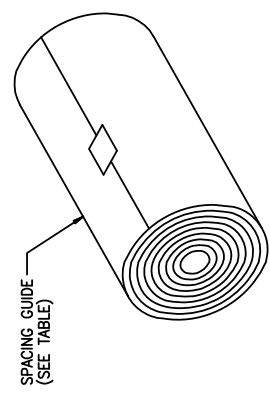

CHAIN MTG. KIT PART NUMBER	CHAIN SECTION P/N / QUANTITY	CHAIN LENGTH	SPACING GUIDE P/N / DESCRIPTION	KIT NET WT.
1012ML - 1	1012-58-1 / 4	30"	1012-145-1 / 2" x 47"	1.4 lbs. (0.6 Kg)
1012ML - 2	1012-58-1 / 2	30"	1012-145-2 / 2" x 81"	1.9 lbs. (0.9 Kg)
	1012-58-2 / 2	60"		

DO NOT SCALE THIS DRAWING UNLESS OTHERWISE SPECIFIED. DIMENSIONS ARE IN INCHES (MM) TOLERANCES IN- INCHES ± .1 (MM) ± .2

CONTRACT NO. DR. H.J. DATE 11/20/96
 CHK. DATE
 ENG. DATE
 PRD. DATE
 APP. DATE
 CERTIFIED DATE

CONTROLTRON
 HAUPPAUGE, NY 11786

**INSTALLATION/OUTLINE
 LADDER CHAIN MOUNTING KIT**

SIZE CODE IDENT NO. **C 21614** 1012ML - 8 REV. **B**
 SCALE: NONE WT. SHEET 1 OF 1

4

3

2

1

1

2

3

4

INSTALLATION PROCEDURE - SEE DRAWING REFERENCES

1. USING THE INSTALLATION MENU PROCEDURES PRESENTED IN THE 1010 FIELD MANUAL, CONFIRM THAT YOU HAVE THE APPROPRIATE TRANSDUCERS AND TRACK FOR REFLECT MODE OPERATION ON THE CHOSEN PIPE.
2. SELECT MOUNTING LOCATION;
 - a) CHOOSE LOCATION WHICH REMAINS FULL AT ZERO FLOW. WHERE POSSIBLE LOCATE TRACK ASSY TEN (10) PIPE DIAMETERS OR MORE FROM BEND TO ENSURE FULLY DEVELOPED AND STABLE FLOW PROFILE.
 - b) ON HORIZONTAL PIPE, SELECT HORIZONTAL PLANE, IF POSSIBLE, TO AVOID SEDIMENT BLOCKAGE OF TRANSDUCER SIGNAL.
3. PREPARE PIPE FOR TRACK MOUNT;
 - a) REMOVE GRIT, CORROSION, COATING OR HEAVY PAINT
 - b) CLEAN AND DEGREASE SURFACE
 - c) DO NOT MOUNT OVER FROST.
 - d) CONDITION PIPE SURFACE TO ACCEPT THE TRACK TRANSDUCERS. USE THE ABRASIVE PAD PROVIDED.
4. MOUNT TRACK ON PIPE;
 - a) PLACE TRACK RAIL ASSY (ASSY WITH CHAIN) AGAINST PIPE. WHILE HOLDING TRACK, WRAP CHAIN AROUND PIPE AND ATTACH CHAIN TO THE TENSION SCREW HOOK.
 - b) ROTATE ASSY AROUND THE PIPE FOR PROPER POSITIONING. ONCE THAT HAS BEEN ACHIEVED, SECURE THE TRACK RAIL ASSY TO THE PIPE WITH THE CHAIN.
5. LOCATE TRANSDUCERS;
 - a) CONSULTING THE 1010 FIELD MANUAL, USE THE INSTALLATION MENU TO DETERMINE THE APPROPRIATE INDEX HOLES FOR YOUR APPLICATION AND INSERT PINS.
 - b) ATTACH RIGHT ANGLE BNC ADAPTER TO INTEGRAL BNC CONNECTOR ON EACH TRANSDUCER.
 - c) APPLY A THIN BAND OF THE ULTRASONIC COUPLANT PROVIDED TO THE BASE OF EACH TRANSDUCER.
 - d) INSERT TRANSDUCERS INTO TRACK AS SHOWN, BANKING AGAINST INDEX PINS. SECURE TRANSDUCERS WITH CLAMPS.
6. MAKE TRANSDUCER CABLE CONNECTIONS IN ACCORDANCE WITH THE APPROPRIATE FLOW COMPUTER INSTALLATION DRAWING AND 1010 FIELD MANUAL.
7. SEE DRAWING 1012TP-8 AND 1011PPS-8 FOR TRACK AND TRANSDUCER OUTLINE DIMENSIONS.

REFLECT MODE INSTALLATION
1011P UNIVERSAL TRANSDUCER AND TRACK

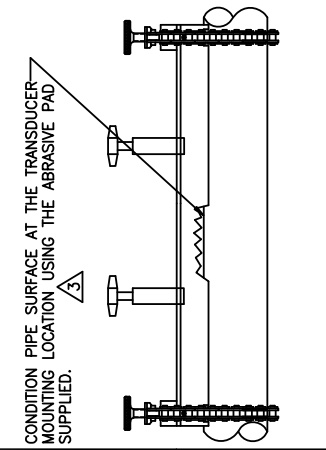
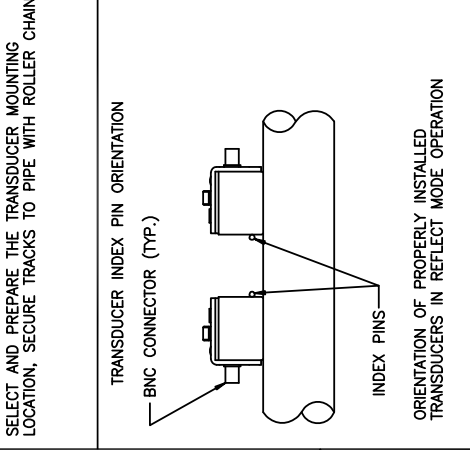
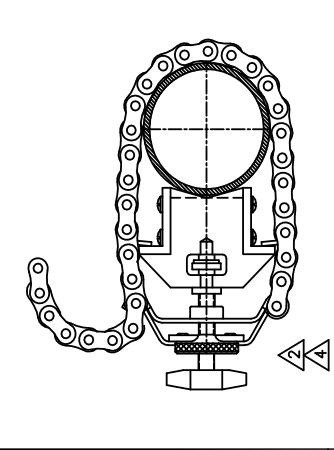
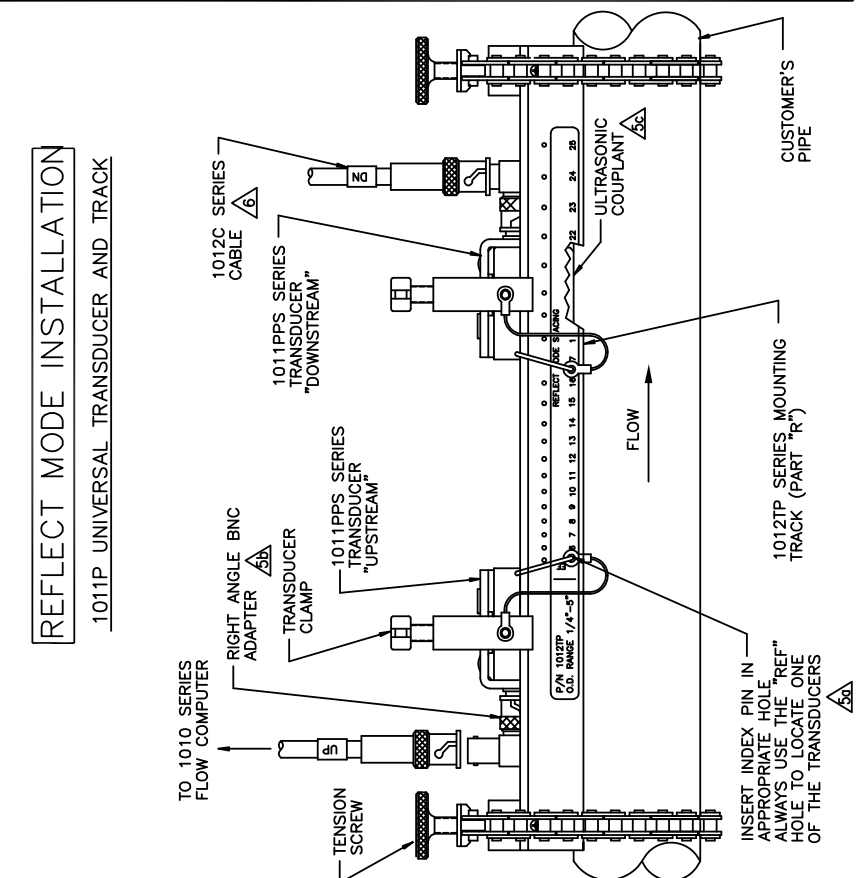

CONTROLTRON
HAUPPAUGE, NY 11788

INSTALLATION DRAWING
1010 SERIES TRANSDUCERS
AND MOUNTING TRACKS

SIZE	CODE IDENT NO.	REV.
C	21614	1012TP-7
SCALE: NONE	WT.	SHEET 1 OF 2

DO NOT SCALE THIS DRAWING
UNLESS OTHERWISE SPECIFIED:
DIMENSIONS ARE IN INCHES (MM)
TOLERANCES ON-

DR	HJJ	DATE	6/10/98
CHK		DATE	
ENG		DATE	
PRD		DATE	
APPD		DATE	
CERTIFIED		DATE	

CONTRACT NO. _____

INCHES
+/- .1

(MM)
+/- .2

2

3

4

1012TP-8 AND 1011PPS-8 FOR TRACK AND TRANSDUCER OUTLINE DIMENSIONS.

1012TP-7

1012TP-7A rev.B

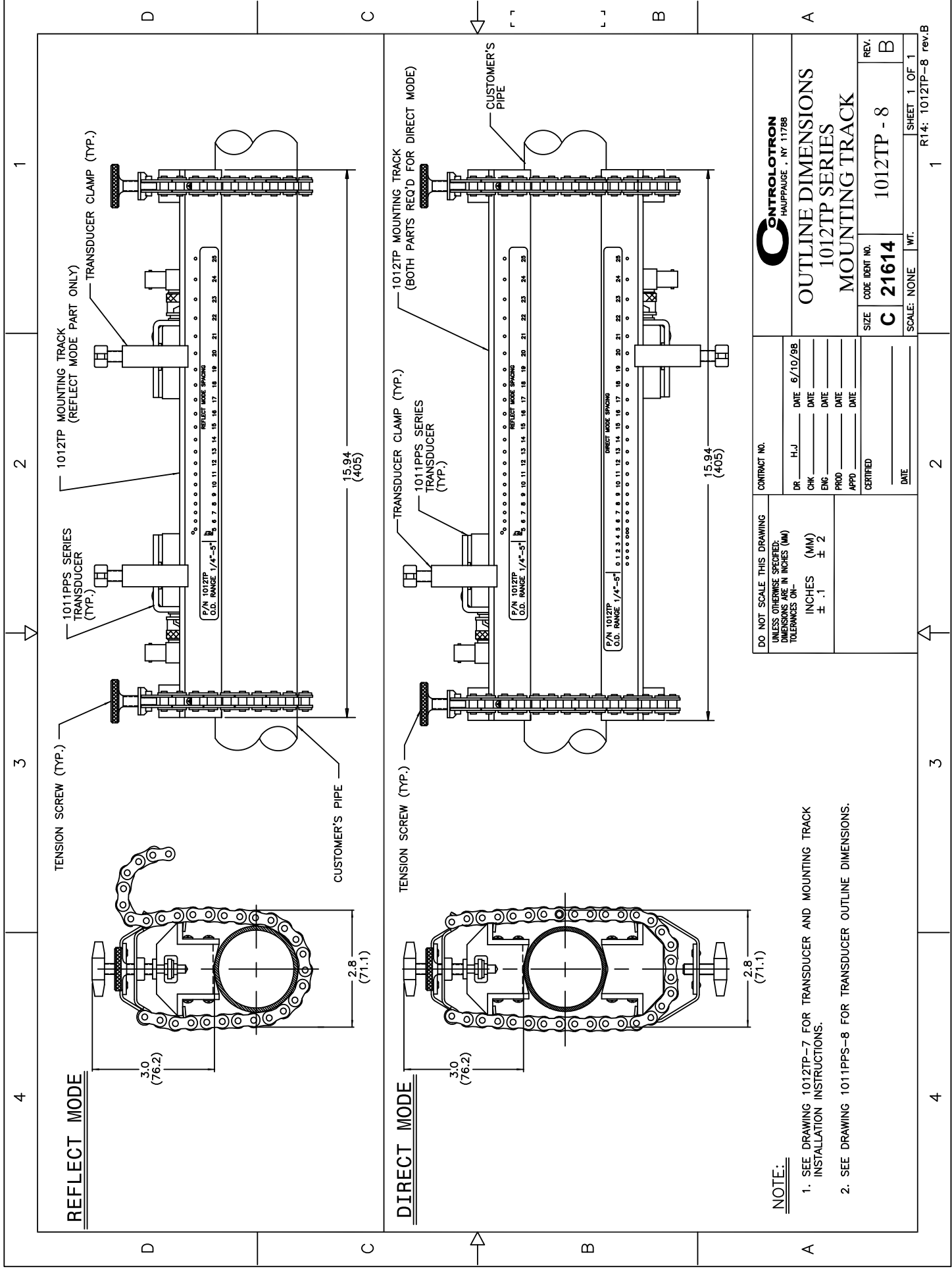

REFLECT MODE

DIRECT MODE

NOTE:

- SEE DRAWING 1012TP-7 FOR TRANSDUCER AND MOUNTING TRACK INSTALLATION INSTRUCTIONS.
- SEE DRAWING 1011PPS-8 FOR TRANSDUCER OUTLINE DIMENSIONS.

DO NOT SCALE THIS DRAWING
UNLESS OTHERWISE SPECIFIED:
DIMENSIONS ARE IN INCHES (MM)
TOLERANCES ON-

INCHES (MM)
± .1 (± 2)

CONTRACT NO.

DR	H-J	DATE	6/10/99
CHK		DATE	
ENG		DATE	
PROD		DATE	
APPD		DATE	
CERTIFIED			
DATE			



**OUTLINE DIMENSIONS
1012TP SERIES
MOUNTING TRACK**

SIZE	CODE IDENT NO.	REV.
C	21614	B
SCALE: NONE	WT.	
	1012TP - 8	
		SHEET 1 OF 1

REFLECT MODE INSTALLATION

1011HP HIGH PRECISION TRANSDUCER AND TRACK

INSTALLATION PROCEDURE - SEE DRAWING REFERENCES Δ

1. USING THE INSTALLATION MENU PROCEDURES PRESENTED IN THE 1010 FIELD MANUAL, CONFIRM THAT YOU HAVE THE APPROPRIATE TRANSDUCERS AND TRACK FOR REFLECT MODE OPERATION ON THE CHOSEN PIPE.
2. SELECT MOUNTING LOCATION:
 - a) CHOOSE LOCATION WHICH REMAINS FULL AT ZERO FLOW.
 - b) WHERE POSSIBLE LOCATE TRACK ASSY. TEN (10) PIPE DIAMETERS OR MORE FROM BEND TO ENSURE FULLY DEVELOPED AND STABLE FLOW PROFILE.
 - c) ON HORIZONTAL PIPE, SELECT HORIZONTAL PLANE, IF POSSIBLE, TO AVOID SEDIMENT BLOCKAGE OF TRANSDUCER SIGNAL.
3. PREPARE PIPE FOR TRACK MOUNT:
 - a) REMOVE GRIT, CORROSION, COATING OR HEAVY PAINT
 - b) CLEAN AND DEGREASE SURFACE
 - c) DO NOT MOUNT OVER FROST.
 - d) CONDITION PIPE SURFACE: LOCALLY SMOOTH THE PIPE SURFACE TO ACCEPT THE TRANSDUCERS. USE THE ABRASIVE PAD PROVIDED.
4. MOUNT TRACK ON PIPE:
 - a) PLACE TRACK RAIL ASSY. (ASSY. WITH CHAIN) AGAINST PIPE. WHILE HOLDING TRACK WRAP CHAIN AROUND PIPE AND ATTACH CHAIN TO THE TENSION SCREW HOOK.
 - b) ROTATE ASSY AROUND THE PIPE FOR PROPER POSITIONING. ONCE THAT HAS BEEN ACHIEVED, SECURE THE TRACK RAIL ASSY TO THE PIPE WITH THE CHAIN.
5. LOCATE TRANSDUCERS:
 - a) CONSULTING THE 1010 FIELD MANUAL, USE THE INSTALLATION MENU TO DETERMINE THE APPROPRIATE INDEX HOLES FOR YOUR APPLICATION AND INSERT PINS.
 - b) APPLY A THIN BAND OF THE ULTRASONIC COUPLANT PROVIDED TO THE BASE OF EACH TRANSDUCER.
 - c) INSERT TRANSDUCERS INTO TRACK AS SHOWN, BANKING AGAINST INDEX PINS. SECURE TRANSDUCERS WITH CLAMPS.
6. MAKE TRANSDUCER CABLE CONNECTIONS IN ACCORDANCE WITH THE APPROPRIATE FLOW COMPUTER INSTALLATION DRAWING AND 1010 FIELD MANUAL. SEE DRAWING 1011HNS-7 FOR CONNECTOR MATING DETAILS AND OPTIONS.
7. SEE DRAWINGS 1012TPH-8 AND 1011HPS-8 FOR TRACK AND TRANSDUCER OUTLINE DIMENSIONS.

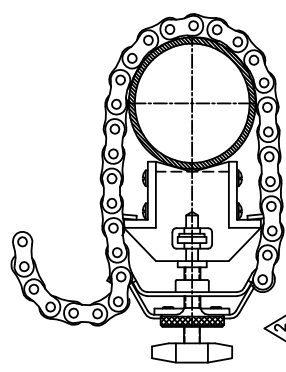
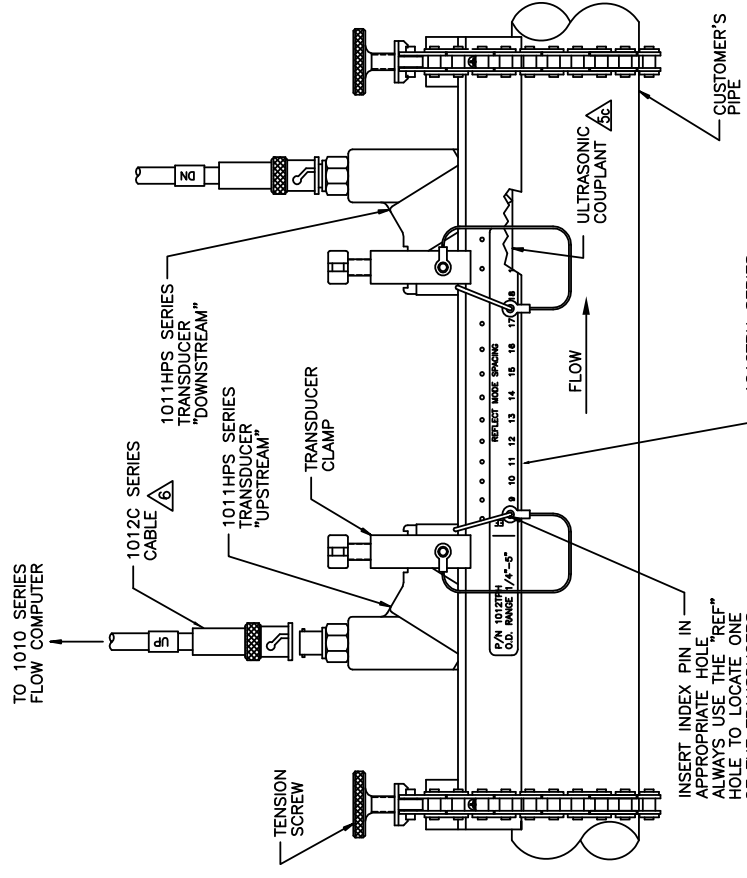

SELECT AND PREPARE THE TRANSDUCER MOUNTING LOCATION, SECURE TRACKS TO PIPE WITH ROLLER CHAIN

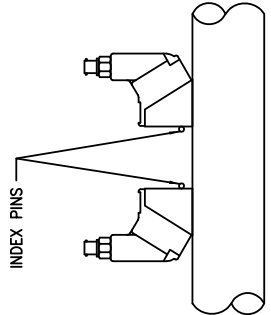

TRANSDUCER INDEX PIN ORIENTATION

ORIENTATION OF PROPERLY INSTALLED TRANSDUCERS IN REFLECT MODE OPERATION

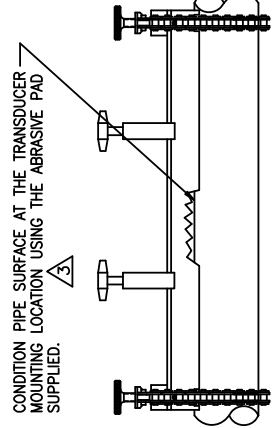

CONDITION PIPE SURFACE AT THE TRANSDUCER MOUNTING LOCATION USING THE ABRASIVE PAD SUPPLIED.

CONTROLTRON
HAUPPAUGE, NY 11788

INSTALLATION DRAWING

1010 SERIES TRANSDUCERS AND MOUNTING TRACKS

SIZE: **C 21614** CODE IDENT NO. REV. **B**
 1012TPH-7 SHEET 1 OF 2

SCALE: NONE WT. 1

R14: 1012TPH-7A rev.B

DO NOT SCALE THIS DRAWING UNLESS OTHERWISE SPECIFIED: DIMENSIONS ARE IN INCHES (MM) TOLERANCES ON-

INCHES (MM) +\ - .1 +\ - .2

CONTRACT NO. DATE 6/10/98

DR H,J DATE DATE DATE

CHK DATE DATE DATE

ENG DATE DATE DATE

PROJ DATE DATE DATE

APPD DATE DATE DATE

CERTIFIED DATE

DIRECT MODE INSTALLATION

1011HP HIGH PRECISION TRANSDUCER AND TRACK TO 1010 SERIES FLOW COMPUTER

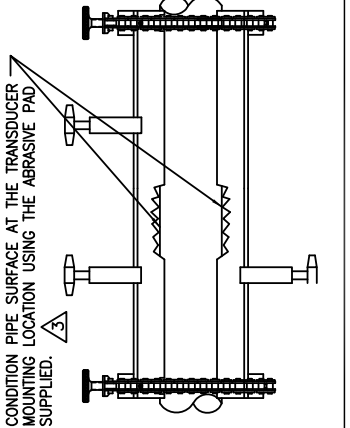
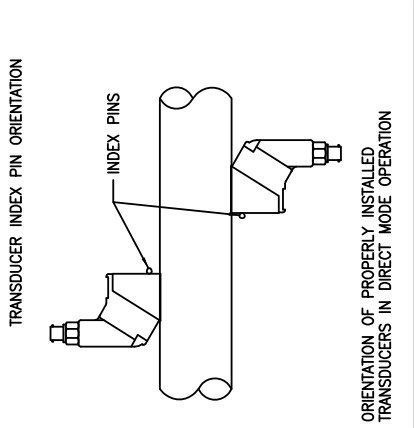
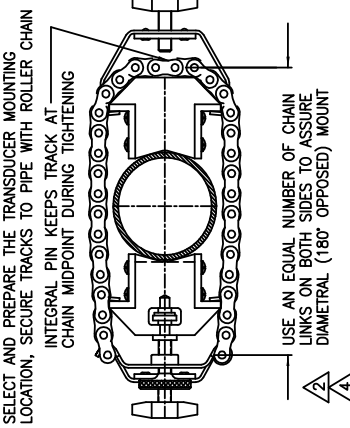
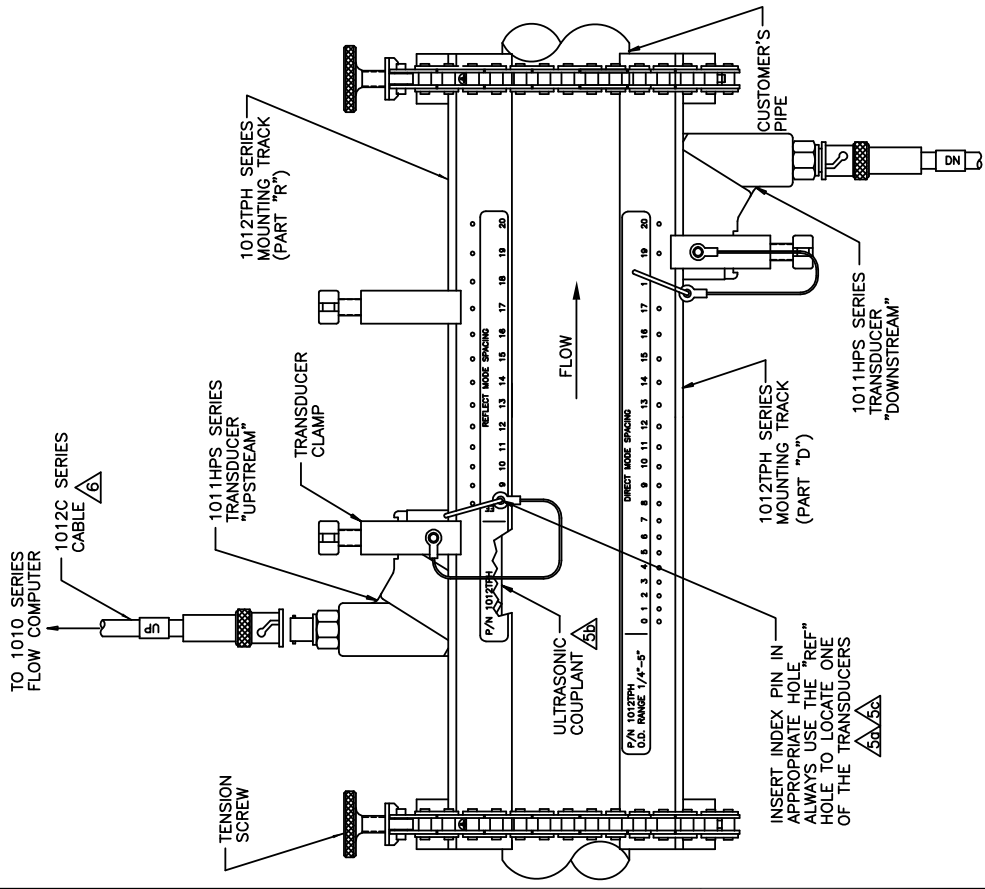

- INSTALLATION PROCEDURE - SEE DRAWING REFERENCES**
1. USING THE INSTALLATION MENU, PROCEDURES PRESENTED IN THE 1010 FIELD MANUAL, CONFIRM THAT YOU HAVE THE APPROPRIATE TRANSDUCERS AND TRACK FOR DIRECT MODE OPERATION ON THE CHOSEN PIPE.
 2. SELECT MOUNTING LOCATION:
 - a) CHOOSE LOCATION WHICH REMAINS FULL AT ZERO FLOW.
 - b) WHERE POSSIBLE LOCATE TRACK ASSY. TEN (10) PIPE DIAMETERS OR MORE FROM BEND TO ENSURE FULLY DEVELOPED AND STABLE FLOW PROFILE.
 - c) ON HORIZONTAL PIPE, SELECT HORIZONTAL PLANE, IF POSSIBLE, TO AVOID SEDIMENT BLOCKAGE OF TRANSDUCER SIGNAL.
 3. PREPARE PIPE FOR TRACK MOUNT:
 - a) REMOVE GRIT, CORROSION, COATING OR HEAVY PAINT
 - b) CLEAN AND DEGRADE SURFACE
 - c) DO NOT MOUNT OVER FROST.
 - d) CONDITION PIPE SURFACE.

LOCALLY SMOOTH THE PIPE SURFACE TO ACCEPT THE TRANSDUCERS. USE THE ABRASIVE PAD PROVIDED.
 4. MOUNT TRACK ON PIPE:
 - a) PLACE TRACK RAIL ASSY (ASSY WITH CHAIN) AGAINST PIPE. WHILE HOLDING TRACK, PLACE THE SECOND TRACK ONTO THE PIPE AND HOLD TOGETHER IN PLACE.
 - b) ROTATE ASSY AROUND THE PIPE FOR PROPER POSITIONING. ONCE THAT HAS BEEN ACHIEVED, SECURE THE TRACK RAIL ASSY TO THE PIPE WITH THE CHAIN.
 - c) IMPORTANT; KEEP EQUAL CHAIN LINKS BETWEEN THE TWO TRACK RAIL ASSY'S WHILE TIGHTENING THE CHAIN (ZONE D4).
 5. LOCATE TRANSDUCERS:
 - a) CONSULTING THE 1010 FIELD MANUAL, USE THE INSTALLATION MENU TO DETERMINE THE APPROPRIATE INDEX HOLES FOR YOUR APPLICATION AND INSERT PINS.
 - b) APPLY A THIN BAND OF THE ULTRASONIC COUPLANT PROVIDED TO THE BASE OF EACH TRANSDUCER.
 - c) INSERT TRANSDUCERS INTO TRACK AS SHOWN, BANKING AGAINST INDEX PINS. SECURE TRANSDUCES WITH CLAMPS.
 6. MAKE TRANSDUCER CABLE CONNECTIONS IN ACCORDANCE WITH THE APPROPRIATE FLOW COMPUTER INSTALLATION DRAWING AND 1010 FIELD MANUAL. SEE DRAWING 1011HNS-7 FOR CONNECTOR MATING DETAILS AND OPTIONS.
 7. SEE DRAWINGS 1012TPH-8 AND 1011HPS-8 FOR TRACK AND TRANSDUCER OUTLINE DIMENSIONS.

ENTROLOTRON
HAUPPAUGE, NY 11788

INSTALLATION DRAWING
1010 SERIES TRANSDUCERS
AND MOUNTING TRACKS

CONTRACT NO. _____
DR. H.I.J. DATE 5/10/98
CHK. _____ DATE _____
ENG. _____ DATE _____
PROD. _____ DATE _____
APPD. _____ DATE _____
CERTIFIED _____ DATE _____

DO NOT SCALE THIS DRAWING
UNLESS OTHERWISE SPECIFIED:
DIMENSIONS ARE IN INCHES (MM)
TOLERANCES UNLESS OTHERWISE SPECIFIED:
INCHES (MM) +.0001 (-.0002)

SIZE CODE IDENT NO. **C 21614** REV. **B**
SCALE: NONE WT. _____ SHEET 2 OF 2

R14: 1012TPH-7B rev.B

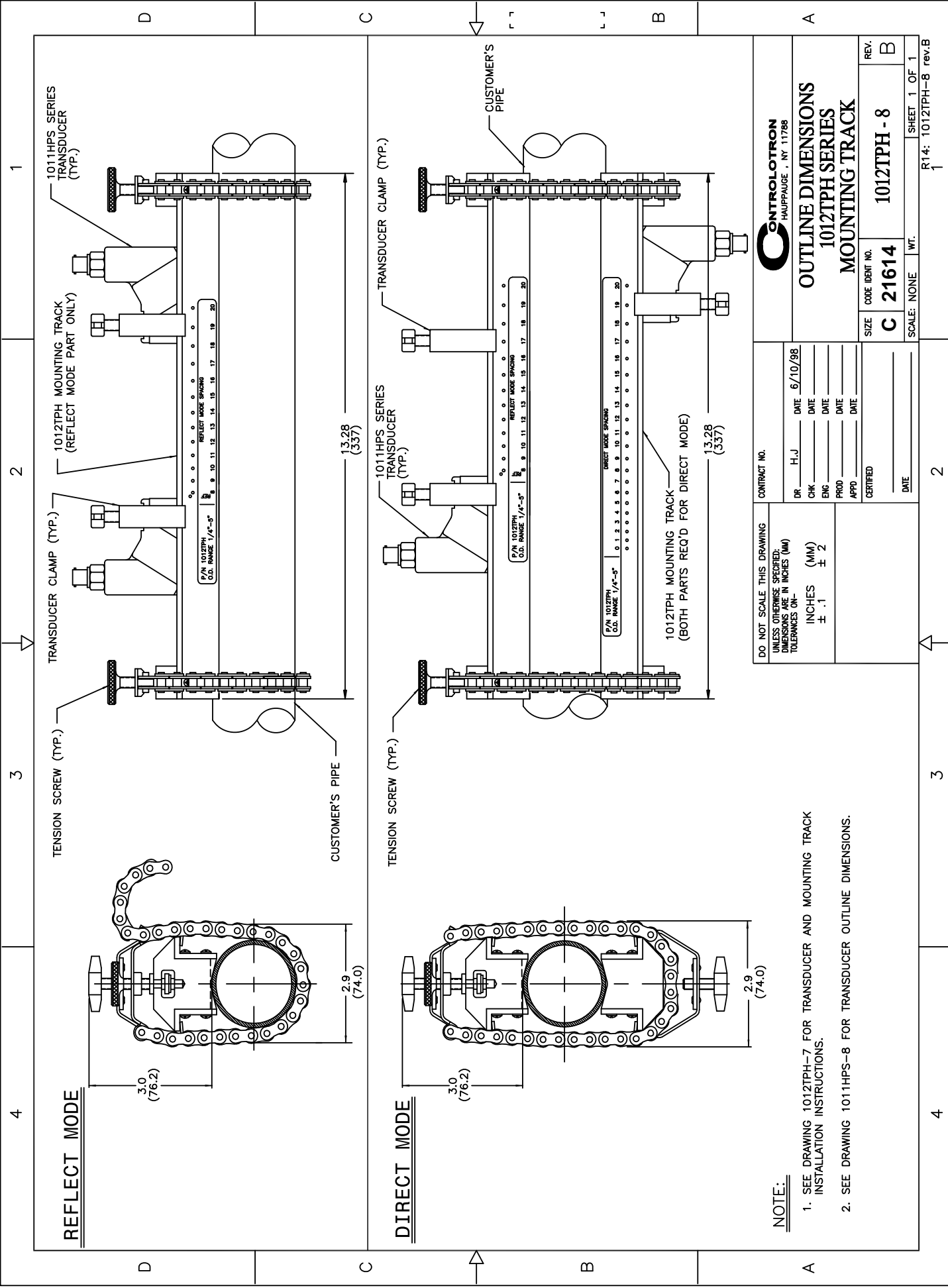

CONTROLTRON HAUPPAUSE, NY 11788	
OUTLINE DIMENSIONS 1012TPH SERIES MOUNTING TRACK	
CONTRACT NO. DR. H-J CHK. DATE 6/10/98 ENG. DATE PRD. DATE APPD. DATE CERTIFIED	SIZE CODE IDENT NO. C 21614 SCALE: NONE WT. 1012TPH - 8 REV. B
DO NOT SCALE THIS DRAWING UNLESS OTHERWISE SPECIFIED: DIMENSIONS IN INCHES (MM) TOLERANCES ON: INCHES (MM) $\pm .1$ (± 2)	SHEET 1 OF 1 R14: 1012TPH-8 rev.B

NOTE:

- SEE DRAWING 1012TPH-7 FOR TRANSDUCER AND MOUNTING TRACK INSTALLATION INSTRUCTIONS.
- SEE DRAWING 1011HPS-8 FOR TRANSDUCER OUTLINE DIMENSIONS.

1015BC-1W POWER ADAPTERS ARE USED WITH
1010WP SERIES FLOW COMPUTERS

1010WP MODELS

(1010WDP WITH ALL I/O OPTIONS SHOWN)

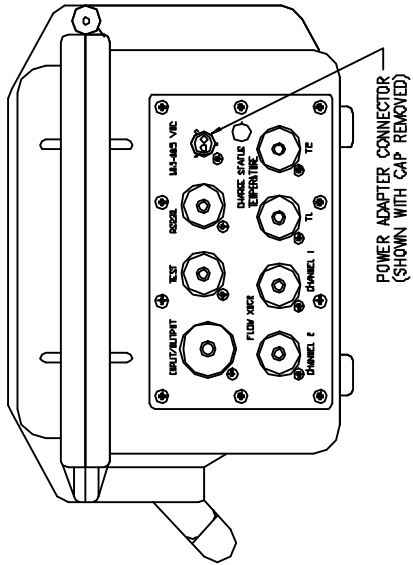

POWER ADAPTER CONNECTOR
(SHOWN WITH CAP REMOVED)

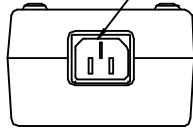

IEC 320 POWER INLET

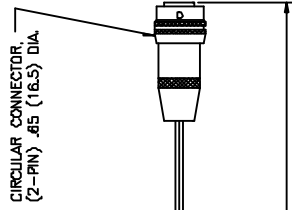
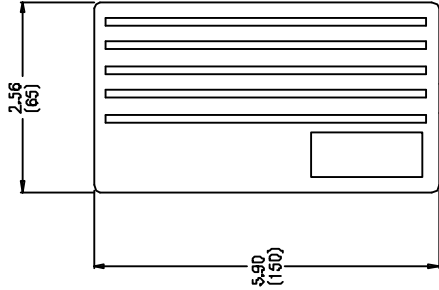
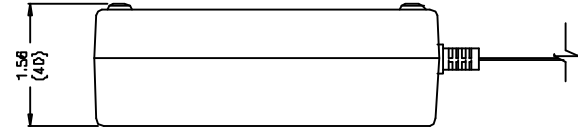

CIRCULAR CONNECTOR,
(2-PIN) .65 (16.5) DIA.

3' MINIMUM (0.9 METERS)



IEC 320 PLUG

1015BC1-1W POWER ADAPTER/BATTERY CHARGER

(SEE NOTE 1)

PLUG VARIES WITH
ASSY PART NO.
(SEE TABLE ABOVE)

NOTES:

- 1. 1015BC-1W POWER ADAPTER/BATTERY CHARGERS ARE SUPPLIED WITH POWER CORDS WITH PLUGS AS TABULATED BELOW.

ASSY PART NO.	POWER CORD	
	PLUG STD.	RATING
1015BCA-1W	CEE 7/7	10A / 230VAC
1015BCC-1W	AS 3112	10A / 250VAC
1015BCD-1W	BS 1363	5A / 240VAC
1015BCJ-1W	JS 8303	12A / 125VAC
1015BCK-1W	NEMA 5-15P	10A / 120VAC
1015BCL-1W	SEV 1011	10A / 250VAC

DO NOT SCALE THIS DRAWING
UNLESS OTHERWISE SPECIFIED.
DIMENSIONS ARE IN INCHES (MM)
TOLERANCES ON

CONTRACT NO.

DR	H.J.	DATE	12/14/98
CHK		DATE	
ENG		DATE	
PROD		DATE	
APP'D		DATE	
CERTIFIED		DATE	



INSTALLATION / OUTLINE
1010 PORTABLE FLOW COMPUTER
POWER ADAPTER/BATTERY CHARGER

SIZE	CODE IDENT NO.	REV.
C	21614	C
SCALE: NONE	VT.	SHEET 1 OF 1
		1015BC-1W-8

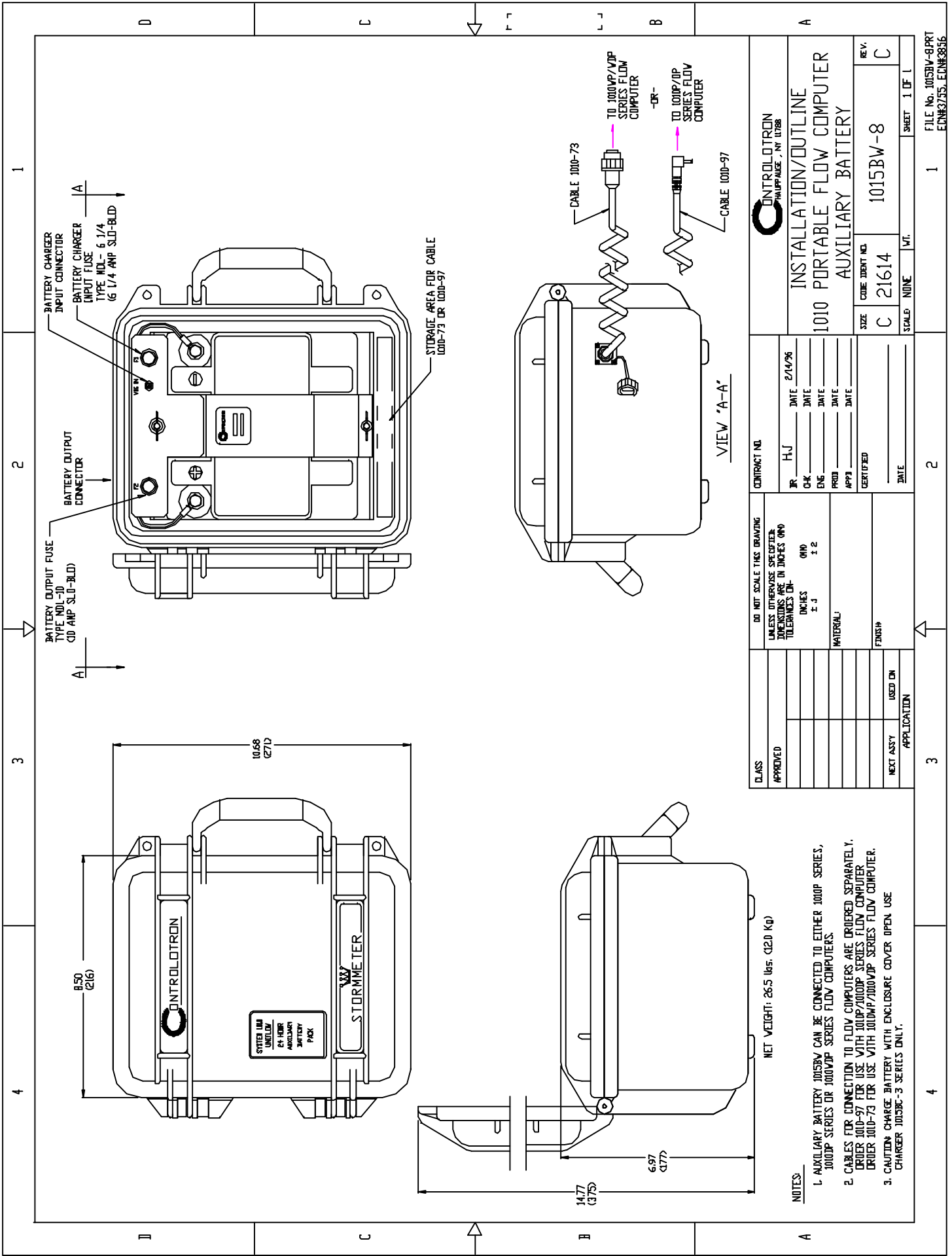

NOTES:

1. AUXILIARY BATTERY 1015BW CAN BE CONNECTED TO EITHER 100UP SERIES, 100IP SERIES OR 100VUP SERIES FLOW COMPUTERS.
2. CABLES FOR CONNECTION TO FLOW COMPUTERS ARE ORDERED SEPARATELY. ORDER 100D-97 FOR USE WITH 100IP/100OP SERIES FLOW COMPUTER. ORDER 100D-73 FOR USE WITH 100UP/100VUP SERIES FLOW COMPUTER.
3. CAUTION: CHARGE BATTERY WITH ENCLOSURE COVER OPEN. USE CHARGER 1003BC-3 SERIES ONLY.

CLASS APPROVED	DO NOT SCALE THIS DRAWING UNLESS OTHERWISE SPECIFIED DIMENSIONS ARE IN INCHES (MM) TOLERANCES ON: INCHES ± .1 MM ± .2		CONTRACT NO. HJ DATE 2/14/96	
	MATERIAL		DATE	
FINISH	FINISH		DATE	
NET ASY	NET ASY		DATE	
APPLICATION		DATE		SHEET 1 OF 1
CONTROLTRON MILWAUKEE, WI 53008		INSTALLATION/OUTLINE 1010 PORTABLE FLOW COMPUTER AUXILIARY BATTERY		REV. C
SIZE C	CODE IDENT NO. C 21614	SCALE NONE	MT.	1015BW-8

REFLECT MODE INSTALLATION

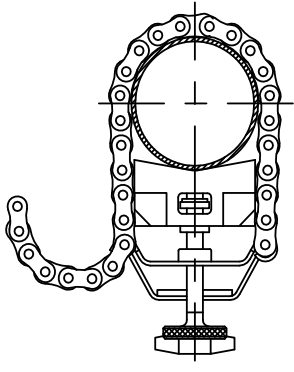

2. SELECT AND PREPARE THE TRANSDUCER MOUNTING LOCATION. SECURE TRACKS TO PIPE WITH ROLLER CHAIN.

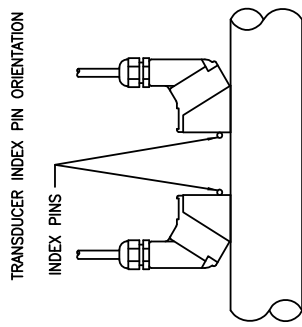

TRANSUCER INDEX PIN ORIENTATION
INDEX PINS
INSERT INDEX PIN IN APPROPRIATE HOLE. ALWAYS USE THE "REF" HOLE TO LOCATE ONE OF THE TRANSDUCERS.

ORIENTATION OF PROPERLY INSTALLED TRANSDUCERS IN REFLECT MODE OPERATION

CONDITION PIPE SURFACE AT THE TRANSDUCER MOUNTING LOCATION USING THE ABRASIVE PAD SUPPLIED.

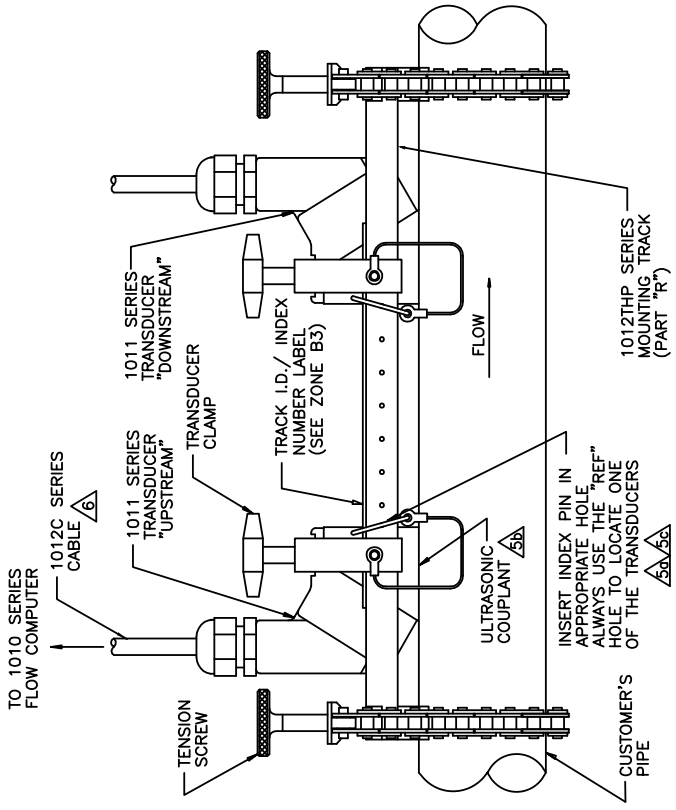
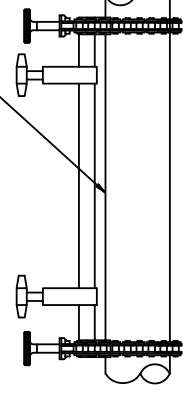

INSTALLATION PROCEDURE - SEE DRAWING REFERENCES

1. USING THE INSTALLATION MENU PROCEDURES PRESENTED IN THE 1010 FIELD MANUAL, CONFIRM THAT YOU HAVE THE APPROPRIATE TRANSDUCERS AND TRACK FOR REFLECT MODE OPERATION ON THE CHOSEN PIPE.
 - a) CHOOSE LOCATION WHICH REMAINS FULL AT ZERO FLOW.
 - b) WHERE POSSIBLE LOCATE TRACK ASSY TEN (10) PIPE DIAMETERS OR MORE FROM BEND TO ENSURE FULLY DEVELOPED AND STABLE FLOW PROFILE.
 - c) ON HORIZONTAL PIPE, SELECT HORIZONTAL PLANE, IF POSSIBLE, TO AVOID SEDIMENT BLOCKAGE OF TRANSDUCER SIGNAL.
2. PREPARE PIPE FOR TRACK MOUNT;
 - a) REMOVE GRIT, CORROSION, COATING OR HEAVY PAINT
 - b) CLEAN AND DEGREASE SURFACE
 - c) DO NOT MOUNT OVER FROST.
 - d) CONDITION PIPE SURFACE: LOCALLY SMOOTH THE PIPE SURFACE TO ACCEPT THE TRANSDUCERS. USE THE ABRASIVE PAD PROVIDED.
3. MOUNT TRACK ON PIPE.
 - a) PLACE TRACK RAIL ASSY (ASSY WITH CHAIN) AGAINST PIPE. WHILE HOLDING TRACK WRAP CHAIN AROUND PIPE AND ATTACH CHAIN TO THE TENSION SCREW HOOK.
 - b) ROTATE ASSY AROUND THE PIPE FOR PROPER POSITIONING. ONCE THAT HAS BEEN ACHIEVED, SECURE THE TRACK RAIL ASSY TO THE PIPE WITH THE CHAIN.
4. LOCATE TRANSDUCERS;
 - a) CONSULTING THE 1010 FIELD MANUAL, USE THE INSTALLATION MENU TO DETERMINE THE APPROPRIATE INDEX HOLES FOR YOUR APPLICATION AND INSERT PINS.
 - b) APPLY A THIN BAND OF THE ULTRASONIC COUPLANT PROVIDED TO THE BASE OF EACH TRANSDUCER.
 - c) INSERT TRANSDUCERS INTO TRACK AS SHOWN, BANKING AGAINST INDEX PINS. SECURE TRANSDUCERS WITH CLAMPS.
5. MAKE TRANSDUCER CABLE CONNECTIONS IN ACCORDANCE WITH THE APPROPRIATE FLOW COMPUTER INSTALLATION DRAWING AND 1010 FIELD MANUAL. SEE DRAWING 1011THS-7 FOR CONNECTOR WIRING DETAILS AND OPTIONS.
6. SEE DRAWINGS 1012THPA-8, 1012THPB-8 AND 1011THS-8 FOR TRACK AND TRANSDUCER OUTLINE DIMENSIONS.

CONTROLTRON
HAUPPAUGE, NY 11788

INSTALLATION DRAWING
1010 SERIES TRANSDUCERS
AND MOUNTING TRACKS

SIZE	CODE IDENT NO.	REV.
C	21614	1012THP-7 A
SCALE: NONE	WT.	SHEET 1 OF 2
		R14: 1012THP-7 sht.1 rev.A
		ER#1316

DO NOT SCALE THIS DRAWING UNLESS OTHERWISE SPECIFIED. DIMENSIONS ARE IN INCHES (MM) TOLERANCES ON-

INCHES	(MM)
+/- .1	+/- .2

CONTRACT NO. _____

DR H:J DATE 9/23/97

CHK _____ DATE _____

ENG _____ DATE _____

PROD _____ DATE _____

APPD _____ DATE _____

CERTIFIED _____

DATE _____

DIRECT MODE INSTALLATION

SELECT AND PREPARE THE TRANSDUCER MOUNTING LOCATION, SECURE TRACKS TO PIPE WITH ROLLER CHAIN

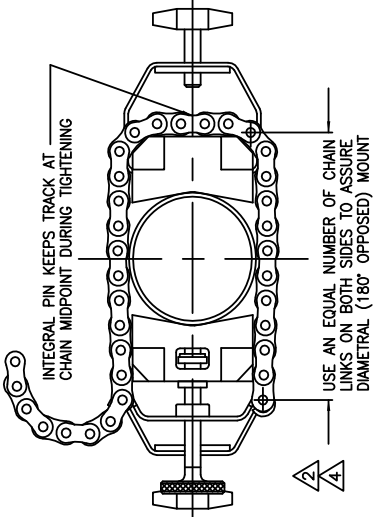

TRANSDUCER INDEX PIN ORIENTATION

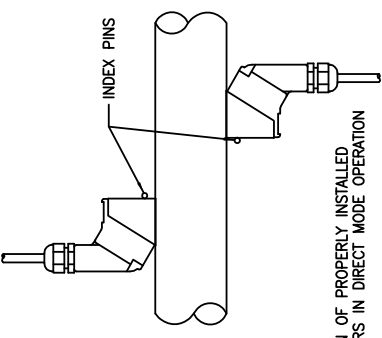

ORIENTATION OF PROPERLY INSTALLED TRANSDUCERS IN DIRECT MODE OPERATION

CONDITION PIPE SURFACE AT THE TRANSDUCER MOUNTING LOCATION USING THE ABRASIVE PAD SUPPLIED.

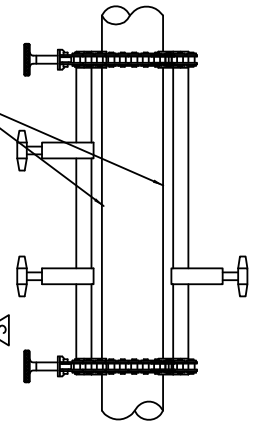

TO 1010 SERIES FLOW COMPUTER

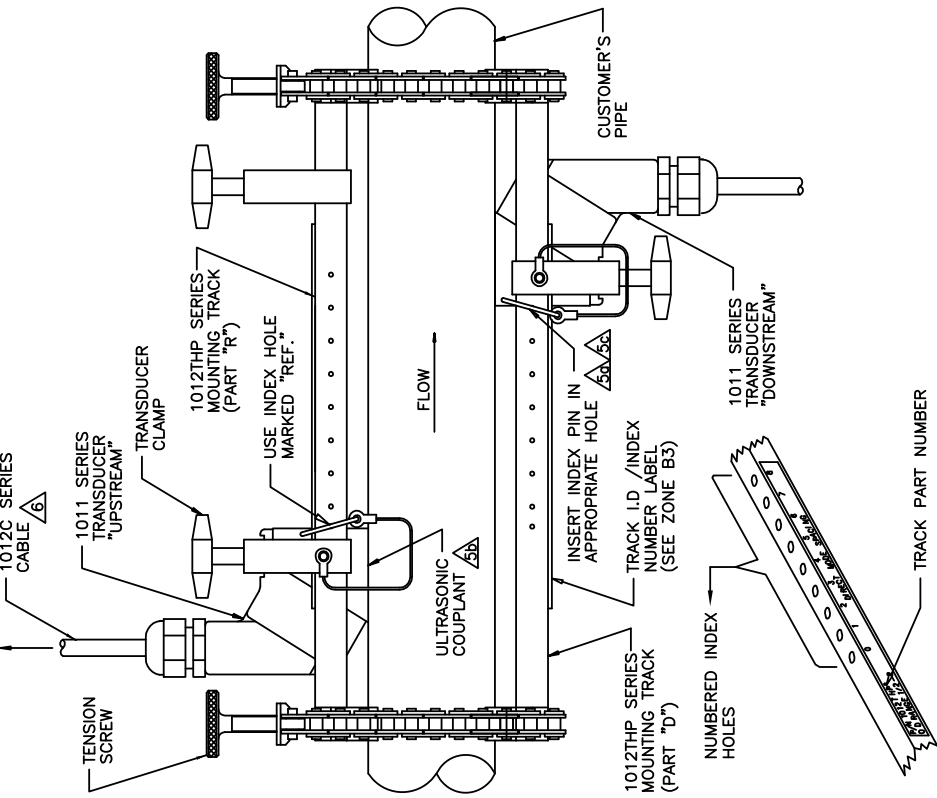

CONTRACT NO.

DR H-J DATE 9/23/97

CHK _____ DATE _____

ENG _____ DATE _____

PROD _____ DATE _____

APPD _____ DATE _____

CERTIFIED _____ DATE _____

DO NOT SCALE THIS DRAWING UNLESS OTHERWISE SPECIFIED. DIMENSIONS ARE IN INCHES (MM) TOLERANCES UN-

INSTALLATION PROCEDURE - SEE DRAWING REFERENCES

1. USING THE INSTALLATION MENU, PROCEDURES PRESENTED IN THE 1010 FIELD MANUAL, CONFIRM THAT YOU HAVE THE APPROPRIATE TRANSDUCERS AND TRACK FOR DIRECT MODE OPERATION ON THE CHOSEN PIPE.
2. SELECT MOUNTING LOCATION:
 - a) CHOOSE LOCATION WHICH REMAINS FULL AT ZERO FLOW.
 - b) WHERE POSSIBLE LOCATE TRACK ASSY. TEN (10) PIPE DIAMETERS OR MORE FROM BEND TO ENSURE FULLY DEVELOPED AND STABLE FLOW PROFILE.
 - c) ON HORIZONTAL PIPE, SELECT HORIZONTAL PLANE, IF POSSIBLE, TO AVOID SEDIMENT BLOCKAGE OF TRANSDUCER SIGNAL.
3. PREPARE PIPE FOR TRACK MOUNT:
 - a) REMOVE GRIT, CORROSION, COATING OR HEAVY PAINT
 - b) CLEAN AND DEGREASE SURFACE
 - c) DO NOT MOUNT OVER FROST.
 - d) CONDITION PIPE SURFACE.

LOCALLY SMOOTH THE PIPE SURFACE TO ACCEPT THE TRANSDUCERS. USE THE ABRASIVE PAD PROVIDED.
4. MOUNT TRACK ON PIPE:
 - a) PLACE TRACK RAIL ASSY (ASSY WITH CHAIN) AGAINST PIPE. WHILE HOLDING TRACK, PLACE THE SECOND TRACK ONTO THE PIPE AND HOLD TOGETHER IN PLACE.
 - b) ROTATE ASSY AROUND THE PIPE FOR PROPER POSITIONING. ONCE THAT HAS BEEN ACHIEVED, SECURE THE TRACK RAIL ASSY TO THE PIPE WITH THE CHAIN.
 - c) IMPORTANT: KEEP EQUAL CHAIN LINKS (4 1/2 - 5 1/2) BETWEEN THE TWO TRACK RAIL ASSY'S WHILE TIGHTENING THE CHAIN. (ZONE D4).
5. LOCATE TRANSDUCERS:
 - a) CONSULTING THE 1010 FIELD MANUAL, USE THE INSTALLATION MENU TO DETERMINE THE APPROPRIATE INDEX HOLES FOR YOUR APPLICATION AND INSERT PINS.
 - b) APPLY A THIN BAND OF THE ULTRASONIC COUPLANT PROVIDED TO THE BASE OF EACH TRANSDUCER.
 - c) INSERT TRANSDUCERS INTO TRACK AS SHOWN, BANKING AGAINST INDEX PINS. SECURE TRANSDUCERS WITH CLAMPS.
6. MAKE TRANSDUCER CABLE CONNECTIONS IN ACCORDANCE WITH THE APPROPRIATE FLOW COMPUTER INSTALLATION DRAWING AND 1010 FIELD MANUAL. SEE DRAWING 1011HNS-7 FOR CONNECTOR MATING DETAILS AND OPTIONS.
7. SEE DRAWINGS 1012THP-8, 1012THP-8 AND 1011HNS-8 FOR TRACK AND TRANSDUCER OUTLINE DIMENSIONS.



INSTALLATION DRAWING 1010 SERIES TRANSDUCERS AND MOUNTING TRACKS

SIZE	CODE IDENT NO.	REV.
C	21614	1012THP-7 A
SCALE: NONE	WT.	SHEET 2 OF 2

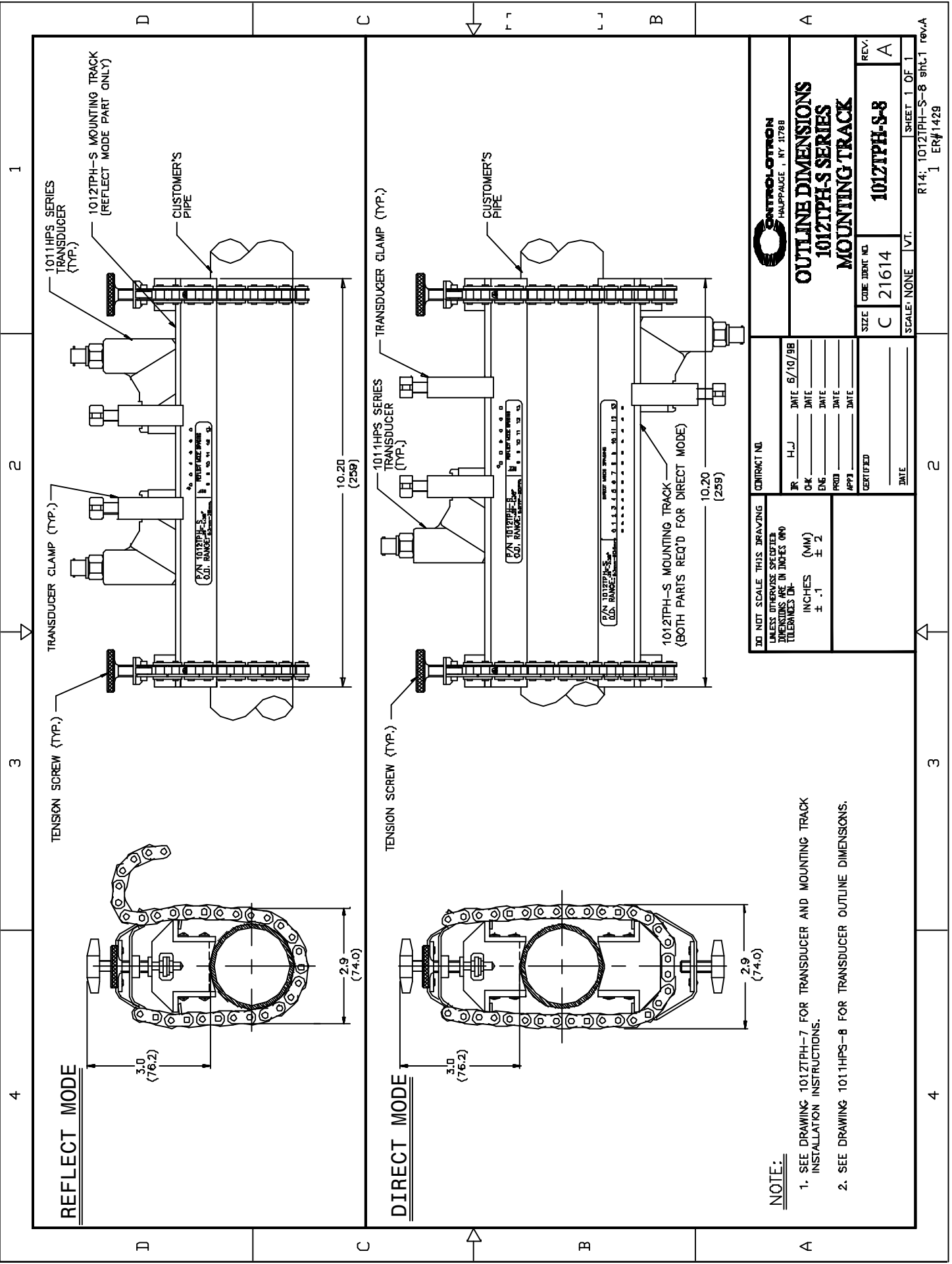

ENTROLOTRON
HAUPPAUGE, N.Y. 11788

OUTLINE DIMENSIONS
1012TPH-S SERIES
MOUNTING TRACK

SIZE	CODE IDENT. NO.	REV.
C	21614	A
SCALE: NONE		SHEET 1 OF 1

CONTRACT NO.	DATE
DR. H.J.	6/10/98
CHK.	DATE
ENG.	DATE
PROD.	DATE
APP'D.	DATE
CERTIFIED	DATE

DO NOT SCALE THIS DRAWING
UNLESS OTHERWISE SPECIFIED
DIMENSIONS ARE IN INCHES (MM)
TOLERANCES UNLESS OTHERWISE SPECIFIED

INCHES (MM)
± .1 (± .2)

NOTE:

- SEE DRAWING 1012TPH-7 FOR TRANSDUCER AND MOUNTING TRACK INSTALLATION INSTRUCTIONS.
- SEE DRAWING 1011HPS-8 FOR TRANSDUCER OUTLINE DIMENSIONS.

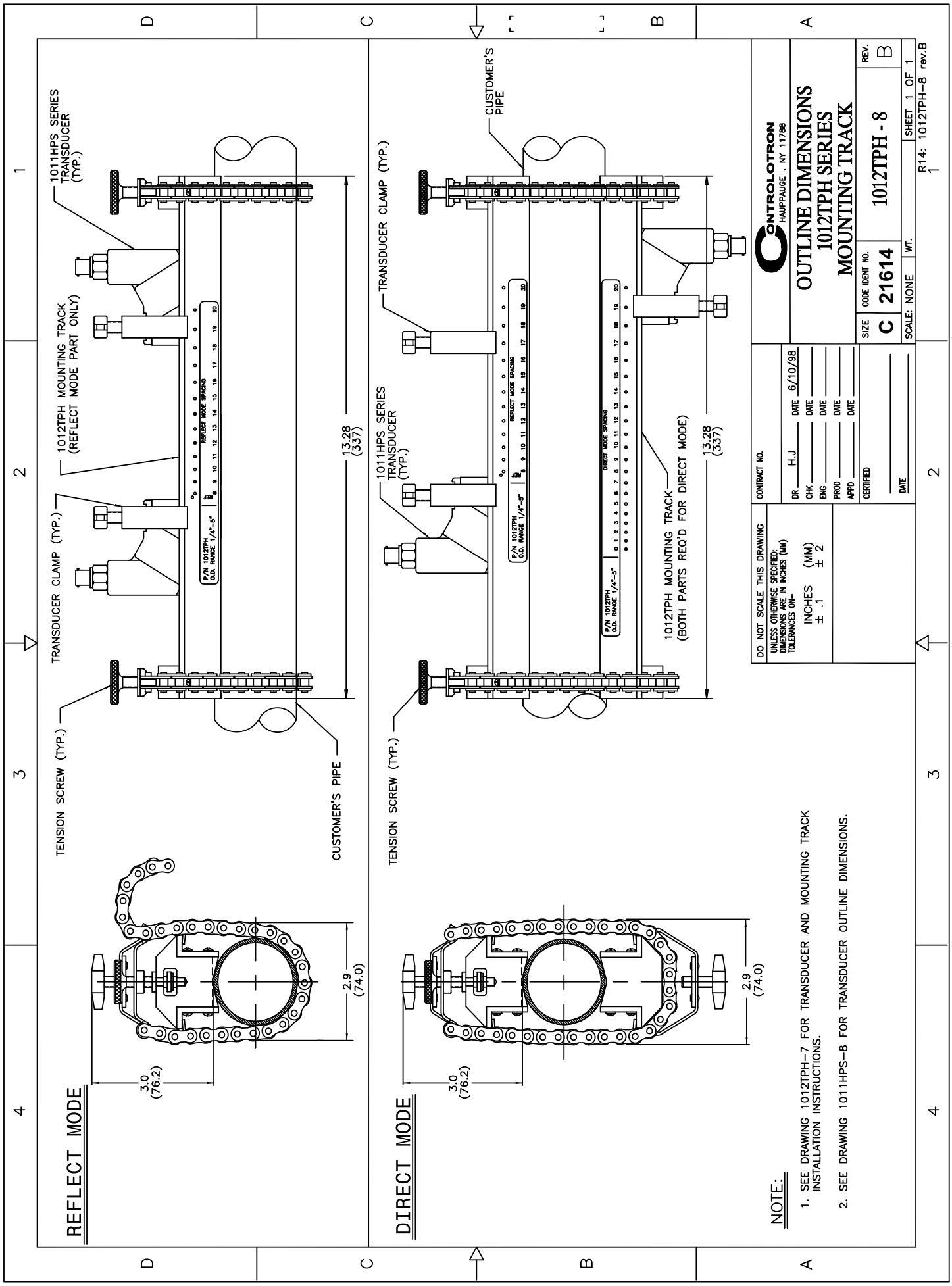

CONTROLTRON
HAUPPAUGE, NY 11788

OUTLINE DIMENSIONS
1012TPH SERIES
MOUNTING TRACK

CONTRACT NO. _____
DR. H.J. DATE 6/10/98
CHK. _____ DATE _____
ENG. _____ DATE _____
PROD. _____ DATE _____
APPD. _____ DATE _____
CERTIFIED _____
DATE _____

SIZE CODE IDENT NO. REV.
C 21614 **1012TPH - 8** **B**

SCALE: NONE WT. SHEET 1 OF 1
R14: 1012TPH-8 rev.B

NOTE:

1. SEE DRAWING 1012TPH-7 FOR TRANSDUCER AND MOUNTING TRACK INSTALLATION INSTRUCTIONS.

2. SEE DRAWING 1011HPS-8 FOR TRANSDUCER OUTLINE DIMENSIONS.

DO NOT SCALE THIS DRAWING
UNLESS OTHERWISE SPECIFIED:
DIMENSIONS ARE IN INCHES (MM)
TOLERANCES ON-
INCHES (MM)
 $\pm .1$ (± 2)

INPUT/OUTPUT TERMINALS:

TERMINAL	SIGNAL	USE
1	GNL	TEST SIGNALS ARE TO BE ACCESSED BY CONTROLTRON TRAINED PERSONNEL ONLY. CONSULT FACTORY
2	WINDOW	
3	DNAI	
4	VSIG	
5	TXCMD	
6	XPWR	
7	+15V	
8	+5V	
9	-15V	
10	VBAT	

INPUT/OUTPUT TERMINALS

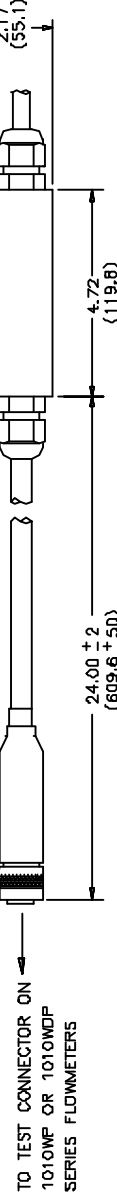
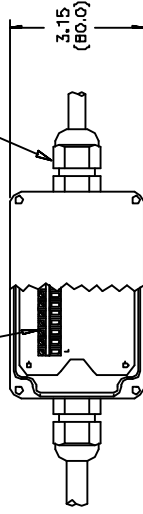

NOTE:

1. TEST CONNECTOR INTERFACE 1015WP-T10 PROVIDES WIRE CLAMP TERMINAL CONNECTIONS FOR USER TEST SIGNALS.

		HAUPPAUGE, NY 11788	
INSTALLATION / OUTLINE TEST CONNECTOR INTERFACE			
CONTRACT NO. HJ	DATE 2/22/99	SIZE CODE IDENT NO. C 21614	REV. A
UNLESS OTHERWISE SPECIFIED DIMENSIONS ARE IN INCHES (MM) TOLERANCES IN INCHES (MM) ± .1 (± 2)	DATE DATE DATE DATE DATE	SCALE: NONE /VT.	SHEET 1 OF 1
DO NOT SCALE THIS DRAWING		1015WP-T10-8	
CERTIFIED		R14: 1015WP-T10-8 sht.1 revA	

INPUT/OUTPUT TERMINALS:

TERMINAL	SIGNAL	FUNCTION	DESCRIPTION	USE	LOAD	WIRING	CABLE LENGTH	NOTES
1	GND.	SIGNAL GROUND	RETURN FOR SIGNALS			#18-#22 AWG	1000 FT. MAX.	
2	R1B	LOGIC OUT 1	LOGIC LEVEL STATE	STATUS INDICATOR/ALARM	5 VOLT LOGIC INPUTS (MAX.)			SEE NOTE 3
3	R2B	LOGIC OUT 2	LOGIC LEVEL STATE	STATUS INDICATOR/ALARM	5 VOLT LOGIC INPUTS (MAX.)			SEE NOTE 3
4	R3B	LOGIC OUT 3	LOGIC LEVEL STATE	STATUS INDICATOR/ALARM	5 VOLT LOGIC INPUTS (MAX.)			SEE NOTE 3
5	R4B	LOGIC OUT 4	LOGIC LEVEL STATE	STATUS INDICATOR/ALARM	5 VOLT LOGIC INPUTS (MAX.)			SEE NOTE 3
6	PGEN1	FREQUENCY OUTPUT 1	ASSIGNABLE LOGIC LEVEL PULSE TRAIN	PULSE DRIVEN FLOW MEASUREMENT	5 VOLT LOGIC INPUTS (MAX.)			
7	PGEN2	FREQUENCY OUTPUT 2	ASSIGNABLE LOGIC LEVEL PULSE TRAIN	PULSE DRIVEN FLOW MEASUREMENT	5 VOLT LOGIC INPUTS (MAX.)			
8	Va1	VOLTAGE OUTPUT 1	ASSIGNABLE 0 TO +10VDC	RECORDING, MONITORING etc.	5K Ω MIN.			
9	Va2	VOLTAGE OUTPUT 2	ASSIGNABLE 0 TO +10VDC	RECORDING, MONITORING etc.	5K Ω MIN.			
10	Ia1	CURRENT OUTPUT 1	ASSIGNABLE 4 TO 20mA	RECORDING, MONITORING etc.	0-1000 Ω @ 30VDC			
11	Ia2	CURRENT OUTPUT 2	ASSIGNABLE 4 TO 20mA	RECORDING, MONITORING etc.	0-450 Ω @ 15VDC			
12	Ia	EXT.CURRENT LOOP PWR	USER SUPPLIED +18 TO +30VDC	DRIVE CURRENT OUTPUTS	25mA MIN.			
13	GND.	SIGNAL GROUND	RETURN FOR SIGNALS					
14	ENTRL1	LOGIC IN 1	TTL LEVEL STATE	NOTOT CH-1	100K Ω			SEE NOTE 3
15	ENTRL2	LOGIC IN 2	TTL LEVEL STATE	NOTOT CH-2	100K Ω			SEE NOTE 3
16	ENTRL3	LOGIC IN 3	TTL LEVEL STATE	CLRTOT CH-1	100K Ω			SEE NOTE 3
17	ENTRL4	LOGIC IN 4	TTL LEVEL STATE	CLRTOT CH-2	100K Ω			SEE NOTE 3
18	In1	CURRENT INPUT 1	4 TO 20MA	EXTERNAL SENSOR INPUT	200 Ω			FLOWMETER LOAD
19	In2	CURRENT INPUT 2	4 TO 20MA	EXTERNAL SENSOR INPUT	200 Ω			FLOWMETER LOAD
20	VIn1	VOLTAGE INPUT 1	0 TO +10VDC	EXTERNAL SENSOR INPUT	100K Ω			FLOWMETER LOAD
21	VIn2	VOLTAGE INPUT 2	0 TO +10VDC	EXTERNAL SENSOR INPUT	100K Ω			FLOWMETER LOAD
22	GND.	SIGNAL GROUND	RETURN FOR SIGNALS					

NOTES:

- SEE 1010 FIELD MANUAL FOR COMPLETE FLOWMETER I/O FUNCTION DESCRIPTIONS AND USER PROGRAMMING OPTIONS.
- I/O CONNECTOR INTERFACE 1015WP-T26 PROVIDES WIRE CLAMP TERMINAL CONNECTIONS FOR USER DATA/CONTROL FUNCTIONS.
- INPUT/OUTPUT FUNCTIONS:
 - A) LOGIC LEVEL STATES: HIGH: 5 TO 3 VOLTS LOW: 1 TO 0 VOLTS
 - B) LOAD CAPABILITY VARIES WITH SUPPLIED VOLTAGE. MAXIMUM LOAD FIGURES INCLUDE WIRING.

SUPPLIED CABLE GLAND ACCOMMODATES CABLE DIA. .17 (4.3) - .47 (11.9)

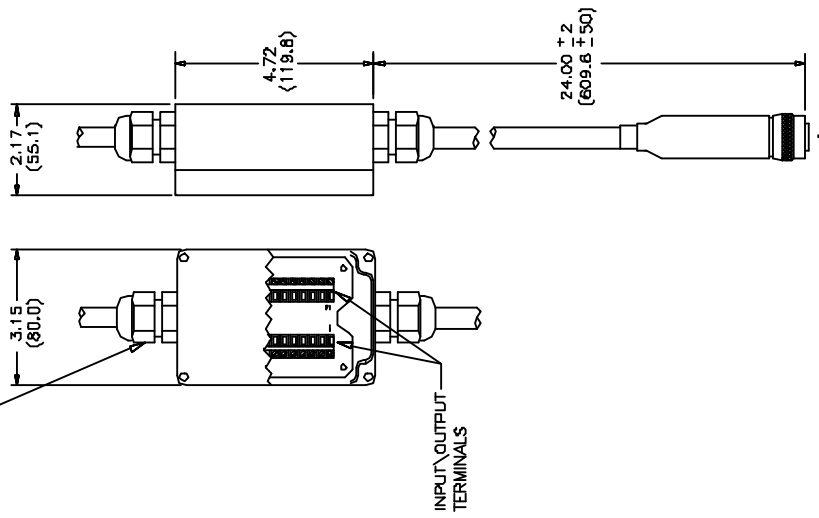

CONTROLATION
HAUPPAUGE, NY 11788

INSTALLATION / OUTLINE I/O CONNECTOR INTERFACE

SIZE	CODE IDENT. NO.	REV.
C	21614	1015WP-T26-8 A
SCALE: NDNE	VT.	SHEET 1 OF 1

CONTRACT NO. _____

DATE 2/22/99

DATE _____

DATE _____

DATE _____

DATE _____

DATE _____

DATE _____

UNLESS OTHERWISE SPECIFIED, DIMENSIONS ARE IN INCHES (MM) TOLERANCES UNLESS OTHERWISE SPECIFIED

± .1 (MM) ± .2

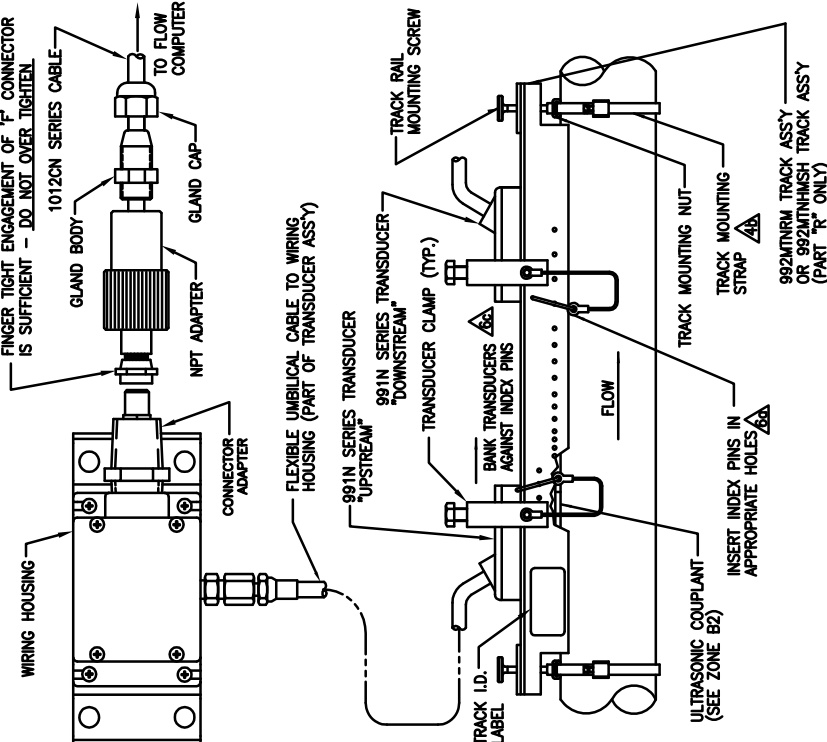
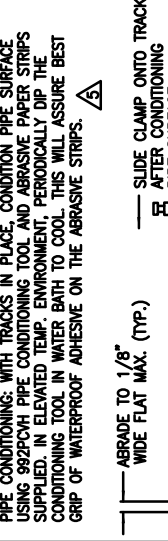
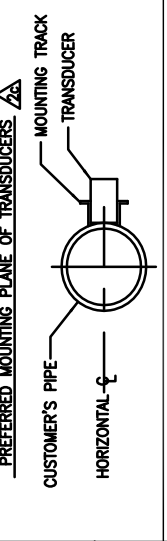
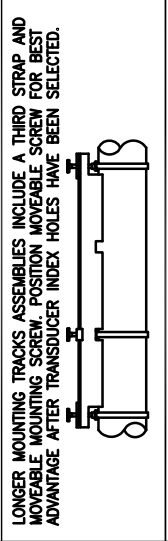
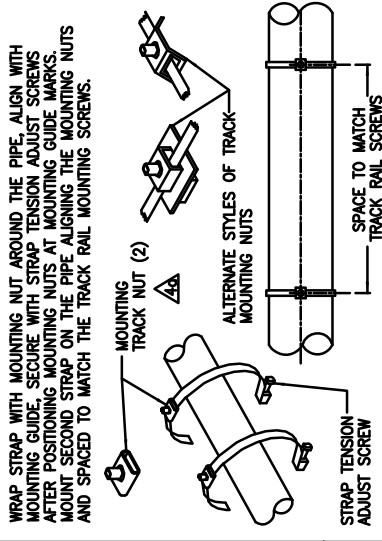

- INSTALLATION PROCEDURE - SEE DRAWING REFERENCES A**
- USING THE INSTALLATION MENU PROCEDURES PRESENTED IN THE FIELD MANUAL, CONFIRM THAT YOU HAVE THE APPROPRIATE TRANSDUCERS AND TRACK FOR REFLECT MODE OPERATION ON THE CHOSEN PIPE.
 - SELECT MOUNTING LOCATION:
 - CHOOSE LOCATION WHICH REMAINS FULL AT ZERO FLOW.
 - WHERE POSSIBLE LOCATE TRACK ASSY TEN (10) PIPE DIAMETERS OR MORE FROM BEND TO ENSURE FULLY DEVELOPED AND STABLE FLOW PROFILE.
 - ON HORIZONTAL PIPE, SELECT HORIZONTAL PLANE, IF POSSIBLE, TO AVOID SEDIMENT BLOCKAGE OF TRANSDUCER SIGNAL.
 - PREPARE PIPE FOR TRACK MOUNT:
 - REMOVE GRIT, CORROSION, COATING OR HEAVY PAINT
 - CLEAN AND DEGREASE SURFACE.
 - DO NOT MOUNT OVER FROST.
 - MOUNT TRACK ON PIPE:
 - SLIP ONE OF THE MOUNTING NUTS PROVIDED ONTO EACH OF THE MOUNTING STRAPS. WRAP THE STRAPS AROUND THE PIPE AT THE SELECTED LOCATION AND ENGAGE THE ADJUSTING SCREWS. POSITION THE MOUNTING NUTS IN LINE WITH THE FLOW AXIS AND SPACED TO MATCH THE SCREWS AT EITHER END OF THE TRACK ASSEMBLY. SECURE THE STRAPS (AND NUTS) BY TIGHTENING THE MOUNTING STRAP ADJUSTING SCREWS.
 - SECURE THE TRACK RAIL ASSEMBLIES TO THE PIPE USING THE TRACK RAIL MOUNTING SCREWS.
 - CONDITION PIPE SURFACE:
 - LOCALLY SMOOTH THE PIPE SURFACE TO ACCEPT THE TRANSDUCERS. USE THE 992PCVH CONDITIONING TOOL AND ABRASIVE PAPER (ADHESIVE BACKED) PROVIDED. FINISHED SURFACE SHOULD BE APPROXIMATELY 1/8" WIDE FLAT AT CENTER OF MOUNTING TRACK.
 - LOCATE TRANSDUCERS:
 - CONSULTING THE FIELD MANUAL, USE THE INSTALLATION MENU TO DETERMINE THE APPROPRIATE INDEX HOLES FOR YOUR APPLICATION AND INSERT PINS.
 - APPLY A THIN BAND OF THE ULTRASONIC COUPLANT PROVIDED TO THE BASE OF EACH TRANSDUCER.
 - INSERT TRANSDUCERS INTO TRACK AS SHOWN, BANKING AGAINST INDEX PINS. SECURE TRANSDUCERS WITH CLAMPS.
 - MAKE TRANSDUCER CABLE CONNECTIONS IN ACCORDANCE WITH THE APPROPRIATE FLOW COMPUTER INSTALLATION DRAWING AND 990 FIELD MANUAL.
 - SEE DRAWING 99TRMH-8 AND 990TRMH-8 FOR TRACK AND TRANSDUCER OUTLINE DIMENSIONS.
 - SEE DRAWING 992-60-7 FOR ASSEMBLY OF CUT-TO-FIT ADJUSTABLE MOUNTING STRAPS.

SIEMENS Siemens Energy & Automation, Inc. Process Instrumentation Business Unit CoCo Ultrasonic Flow - Heppauge, Long Island, NY 11788	
INSTALLATION DRAWING 990 SERIES TRANSDUCER REFLECT MODE, VERY HIGH TEMP.	
SIZE	C 21614
CODE IDENT NO.	990TRMVH-7B
REV.	F
SCALE:	NONE
WT.	
SHEET	1 OF 1

DO NOT SCALE THIS DRAWING UNLESS OTHERWISE SPECIFIED. DIMENSIONS ARE IN INCHES (MM) TOLERANCES ON-	CONTRACT NO.
INCHES ± .1	DR HJJ DATE 11/03/04
(MM) ± 2	CHK _____ DATE _____
	ENG _____ DATE _____
	PROD _____ DATE _____
	APPD _____ DATE _____
	CERTIFIED _____
	DATE _____

INSTALLATION PROCEDURE - SEE DRAWING REFERENCES **A**

- CHOOSE THE APPROPRIATE TRANSDUCER MOUNTING ARRANGEMENT. THE TRANSDUCER MUST BE MOUNTED IN A POSITION WHERE THERE IS NO VIBRATION, AIR BUBBLES, OR PARTICULATE MATTER. (FOR EXAMPLE, "SUBMERSIBLE" THEN THE "IN-LINE" TRANSDUCER CONFIGURATION IS RECOMMENDED. IF THE LIQUID TO BE MEASURED CONTAINS A SMALL AMOUNT OF PARTICULATE MATTER, OR IF ENHANCED FLOW PROFILE AVERAGING IS REQUIRED, THEN THE "DUAL-HEAD" CONFIGURATION IS RECOMMENDED BECAUSE OF ITS ABILITY TO INCREASE TRANSDUCER SENSITIVITY.
- CONFIGURATION OF THE TRANSDUCERS FOR "IN-LINE" MODE:
 - REMOVE (UNSNAP) THE SNAP LINK FROM THE TRANSDUCER ENDS, IF CONNECTED.
 - SNAP THE TRANSDUCER ENDS TOGETHER.
 - WHEN USING THE IN-LINE CONFIGURATION, THE TRANSDUCER CABLE CONNECTIONS ARE DIFFERENT FOR PLASTIC AND METAL PIPES, AS FOLLOWS:
 - FOR USE ON METAL PIPES: CONNECT THE CABLE END MARKED "XMIT" TO TRANSDUCER NUMBER '1' AND THE CABLE END MARKED "RCV" TO TRANSDUCER NUMBER '2'.
 - FOR USE ON PLASTIC PIPES: CONNECT THE CABLE END MARKED "XMIT" TO TRANSDUCER NUMBER '2' AND THE CABLE END MARKED "RCV" TO TRANSDUCER NUMBER '1'.
- CONFIGURATION OF THE TRANSDUCERS FOR "DUAL-HEAD" MODE:
 - DISCONNECT (UNSNAP) THE ENDS OF THE TRANSDUCERS, IF CONNECTED, ALIGN AND HOLD BOTH TRANSDUCERS NEXT TO EACH OTHER IN ORDER TO FACILITATE ATTACHMENT OF THE SNAP LINK. CONNECT SNAP LINK TO FRONT AND REAR.
 - WHEN THE "DUAL-HEAD" CONFIGURATION IS USED, IT DOES NOT MATTER WHICH TRANSDUCER IS ASSIGNED FOR THE TRANSMIT (XMIT) OR RECEIVE (RCV).
- SELECT MOUNTING LOCATION / PREPARE PIPE AND TRANSDUCER:
 - SELECT A SECTION OF PIPE THAT REMAINS FULL AT ALL FLOW RATES. REMOVE ANY EXTERNAL CORROSION OR LOOSE PAINT AND PREPARE A CLEAN, SMOOTH MOUNTING SPACE ON THE PIPE, APPROXIMATELY THE SIZE SHOWN.
 - APPLY APPROXIMATELY 1/8" THICK BEAD OF THE PROPER SONIC COUPLANT COMPOUND ALONG THE BOTTOM OF EACH TRANSDUCER.
- IF A TOUCH-ON MEASUREMENT IS TO BE TAKEN; IN MOST CASES, TOUCH-ON FLOW MEASUREMENT CAN BE ACCOMPLISHED USING THE "IN-LINE" CONFIGURATION. PLACE THE TRANSDUCER ASSEMBLY WITH COUPLANT APPLIED AND CABLES CONNECTED) AGAINST THE PIPE, DO NOT ALLOW THE TRANSDUCER TO MOVE UNTIL THE MEASUREMENT IS COMPLETE.
- IF THE QUICK MOUNT CHAIN IS USED:
 - FOR THE "IN-LINE" CONFIGURATION USE THE TWO CHAIN ASSEMBLIES WITH THE SHOCK HOOKS. WITH THE TRANSDUCER SWAGED TOGETHER, PASS THE CHAIN THROUGH THE SHOCK HOOKS AND SECURE THE SHOCK HOOKS TO THE TRANSDUCERS WITH COUPLANT APPLIED AND CABLES CONNECTED ON THE PREPARED SPACE ON THE PIPE. WRAP THE CHAINS AROUND THE PIPE. PULL SNUG AND ENGAGE THE CHAINS AND HOOKS. ALIGN THE TRANSDUCERS PERPENDICULAR TO THE PIPE SURFACE, "IN-LINE" WITH THE FLOW AXIS.
 - FOR "DUAL-HEAD" CONFIGURATION USE THE CHAIN ASSEMBLY WITH THE LONG HOOK. WITH THE TRANSDUCERS FASTENED BY THE SNAP LINK, PASS THE CHAIN, SPRING AND HOOK THROUGH THE TWO GUIDES, PLACE THE TRANSDUCERS (WITH COUPLANT APPLIED AND CABLES CONNECTED) ON THE PREPARED SPACE ON THE PIPE. WRAP THE CHAIN AROUND THE PIPE. PULL SNUG AND ENGAGE THE CHAINS AND HOOKS. ALIGN THE TRANSDUCERS PERPENDICULAR TO THE PIPE, "IN-LINE" WITH THE PIPE CIRCUMFERENCE.
- THE 191P1S CAN BE MOUNTED WITH STRAPS FOR SEMI-PERMANENT INSTALLATION. THE PROPER SONIC COUPLANT COMPOUND MUST BE APPLIED TO THE TRANSDUCER. THIS CONFIGURATION REQUIRES TWO MOUNTING STRAPS. THE "DUAL-HEAD" CONFIGURATION USES ONE MOUNTING STRAP. MOUNTING STRAPS MUST BE INSERTED THROUGH THE GUIDES ON THE TRANSDUCERS. ORIENT THE CLAMP SCREW FOR CONVENIENCE, THEN TIGHTEN WITH A SCREWDRIVER OR NUTDRIVER.

1920P SERIES CABLE
TO 194 SERIES FLOW COMPUTER

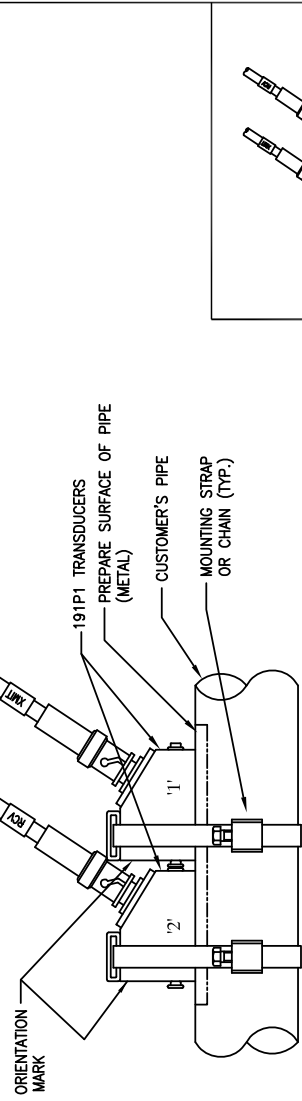

IN-LINE CONFIGURATION

(SHOWN IN TYPICAL INSTALLATION ON METAL PIPE)

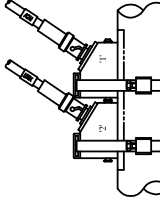

IN-LINE CONFIGURATION

(ON PLASTIC PIPE)

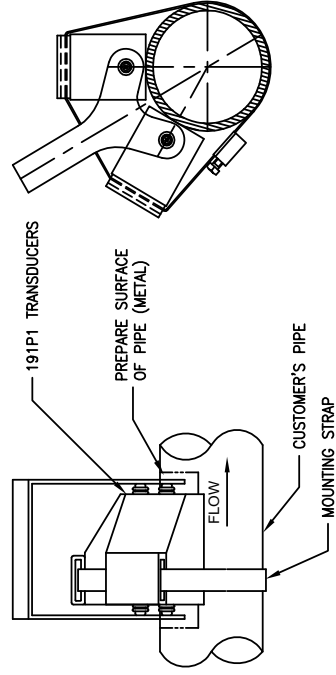

DUAL HEAD CONFIGURATION

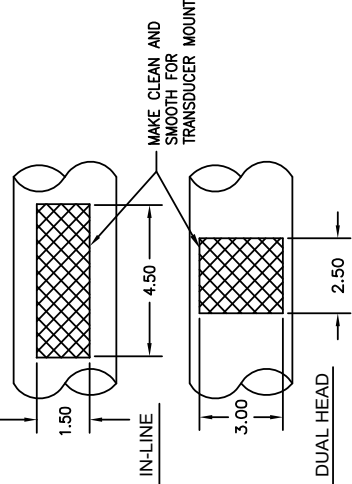

PIPE PREPARATION

CONTRACT NO.

DR	H-J	DATE	1/12/00
CHK		DATE	
ENG		DATE	
PROD		DATE	
APPD		DATE	
CERTIFIED		DATE	

DO NOT SCALE THIS DRAWING UNLESS OTHERWISE SPECIFIED: DIMENSIONS ARE IN INCHES (MM) TOLERANCES UNLESS OTHERWISE SPECIFIED

INCHES ± .1 (MM) ± .2

APPLY A THIN BAND OF COUPLANT TO BASE OF EACH TRANSDUCER BEFORE INSTALLING ON PIPE

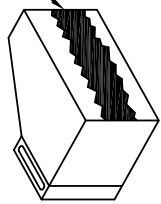

USE OF COUPLANT COMPOUND

CONTROLotron
HAUPAUGE, NY 11788

INSTALLATION DRAWING
191N1S TRANSDUCER
NEMA 4

SIZE	CODE IDENT NO.	REV.
C	21614	B
SCALE:	NONE	WT.
	191P1 - 7	

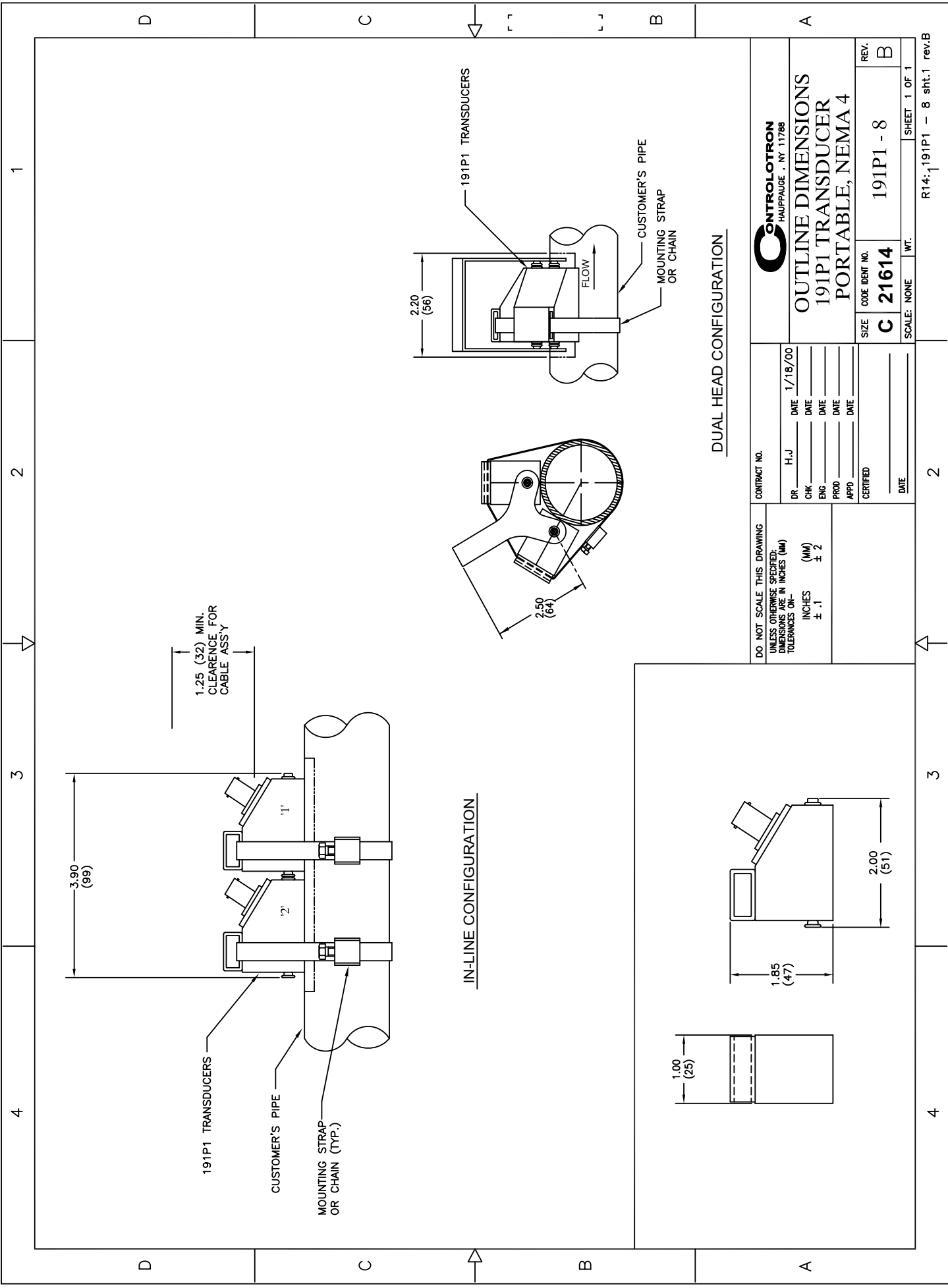

4 3 2 1

D C B A

D C B A

CONTROLTRON <small>HARPPAUGE, NY 11788</small>		OUTLINE DIMENSIONS 191P1 TRANSDUCER PORTABLE, NEMA 4		SIZE C	CODE IDENT NO. 21614	REV. B
DO NOT SCALE THIS DRAWING UNLESS OTHERWISE SPECIFIED: DIMENSIONS ARE IN INCHES (MM) TOLERANCES ON-		CONTRACT NO. _____ DR. H.J. _____ CHK. _____ ENG. _____ PROD. _____ APPD. _____ CERTIFIED _____ DATE _____		DATE <u>1/18/00</u>	SCALE: NONE	WT. _____ SHEET 1 OF 1
INCHES $\pm .1$	(MM) ± 2	DATE _____ DATE _____ DATE _____ DATE _____		R14:191P1 - 8 sht.1 rev.B		

DUAL HEAD CONFIGURATION

IN-LINE CONFIGURATION

ZONE	DATE	APPROVED

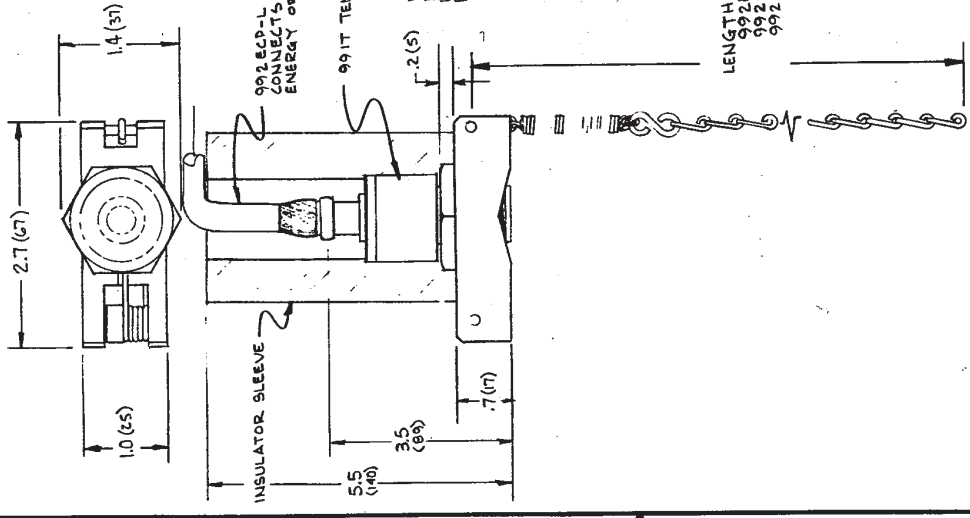

MOUNTING: STEPS 1-3

STEP 1

PASS CHAIN AROUND PIPE & THRU BLOCK

992CD-L CABLE CONNECTS 991T TO THE THERMAL ENERGY OR MASS FLOWMETER

STEP 3

HANDS TIGHTEN RTD 991T. DO NOT TIGHTEN RTD TO THE EXTENT THAT THE BLOCK RISES FROM THE PIPE. TIGHTEN JAM NUT (PIN 991-1603) TO LOCK RTD IN PLACE.

LENGTH OF CHAIN (APPROXIMATE)
 992EMTP-2 - 2 1/2' (.75 M)
 992EMTP-3 - 7' (2.1 M)
 992EMTP-4 - 13' (4.0 M)

STEP 2

WITH ONE HAND HOLDING THE BLOCK, PULL THE CHAIN TO ITS FULL TRAVEL. FULL TRAVEL LIMITED BY CABLE STOP. SLOWLY ALLOW CHAIN SPRING TO RETRACT AND ENGAGE ARM OF TORSION SPRING.

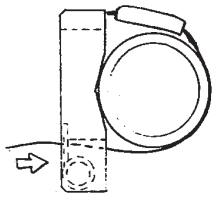

REMOVAL

REMOVE RTD & JAM NUT. WITH ONE HAND HOLDING THE BLOCK, PULL THE CHAIN UP AND OVER THE TOP OF THE BLOCK. THIS WILL DISENGAGE THE ARM OF THE TORSION SPRING FROM THE CHAIN LINK. SLOWLY ALLOW THE CHAIN / SPRING TO RETRACT, WHILE STILL HOLDING THE CHAIN OVER THE BLOCK. THIS WILL ALLOW THE CHAIN TO FALL THRU THE BLOCK WITHOUT ENGAGING THE TORSION SPRING.

991T SENSOR W/AL PLATE. SERIAL NUMBER MEASUREMENT SERIAL NUMBERS MUST MATCH (S1 1234, 12345)

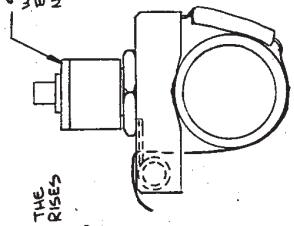

FOR HARSH OR HEAVY CONDENSATE ENVIRONMENTS:
 SVC. TEMP. RANGE -40°F TO +180°F

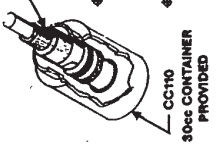

TABLE I

PART NUMBER	PIPE O.D. RANGE
992EMTP-2	1 1/4" TO 8" O.D.
992EMTP-3	6" TO 24" O.D.
992EMTP-4	20" TO 48" O.D.

- ◆ CCH10 30cc CONTAINER PROVIDED
- ◆ IMMERSER CONNECTOR IN CONTAINER OF CCH10 COMPLETELY FILLING AND COATING IT. BEFORE CONNECTING TO 991T TEMP. SENSOR.
- ◆ ADDITIONAL COATING MAY BE REQUIRED AS PART OF A NORMAL MAINTENANCE SCHEDULE.

NOTES:

1. THERMAL SENSORS ARE SUPPLIED IN Pairs (PIN 991T) FOR THERMAL ENERGY FLOWMETER APPLICATIONS OR SINGLY (991T) FOR TEMPERATURE COMPENSATED MASS FLOWMETER APPLICATIONS.
2. MOUNTING ASSEMBLY 992EMTP 2,3, OR 4 AND CABLES 992CD-L ARE ORDERED SEPARATELY.
3. SEE APPROPRIATE COMPUTER INSTALLATION DRAWINGS FOR WIRING CONNECTIONS AT THE FLOW COMPUTER.

<p>CONTRACT NO. DR RFK DATE 1/24/90</p>	
<p>CHK DL DATE 2-1-90</p>	<p>ENG _____ DATE _____</p>
<p>PROJ _____ DATE _____</p>	<p>APPR _____ DATE _____</p>
<p>CERTIFIED _____</p>	<p>DATE _____</p>
<p>DO NOT SCALE THIS DRAWING UNLESS OTHERWISE SPECIFIED. DIMENSIONS ARE IN INCHES (MM) FRACTIONS ON: DECIMALS: ANGLES: # # # . 1 (2) # # #</p>	
<p>CLASS _____</p>	<p>MATERIAL _____</p>
<p>APPROVED _____</p>	<p>FINISH _____</p>
<p>NEXT ASSY _____</p>	<p>USED ON _____</p>
<p>APPLICATION _____</p>	<p>SCALE 1/8"</p>

<p>CONTROLTRON CORPORATION HAUPPAUGE, LONG ISLAND, N.Y.</p>	
<p>INSTALLATION OUTLINE 991T TEMPERATURE SENSOR PORTABLE</p>	
<p>SIZE CODE IDENT NO. C 21614</p>	<p>REV. B</p>
<p>991TP-7</p>	<p>SHEET 1 OF 1</p>

REVISES	DESCRIPTION	DATE	APPROVED
ZONE 1, 2, 3, 4			

FOR HARSH OR HEAVY CONDENSATE ENVIRONMENTS:
SVC. TEMP. RANGE: -40°F TO +160°F

992EC# TEMPERATURE SENSOR CABLE

◆ IMMERSE CONNECTOR IN CONTAINER OF CC110, COMPLETELY FILLING AND COATING IT, BEFORE CONNECTING TO 991T TEMP. SENSOR.

◆ ADDITIONAL COATING MAY BE REQUIRED AS PART OF A NORMAL MAINTENANCE SCHEDULE.

CC110
30cc CONTAINER PROVIDED

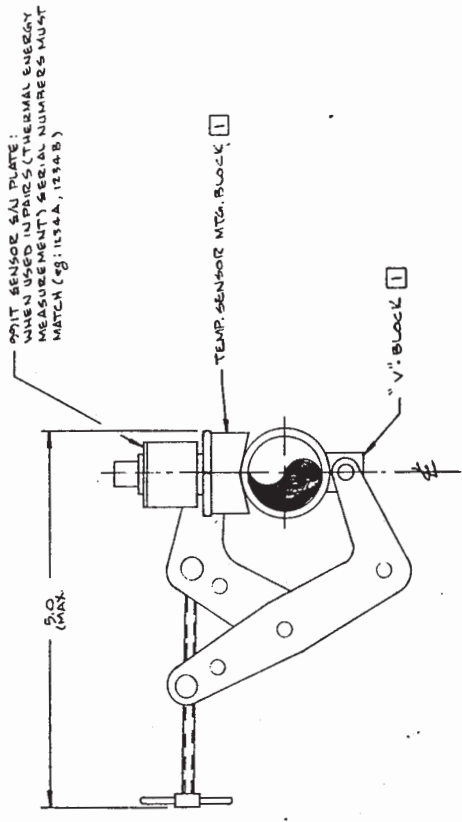
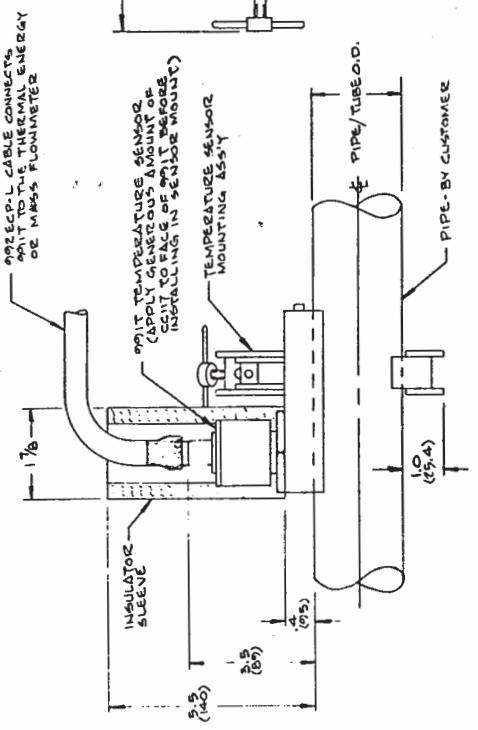
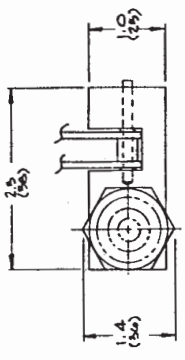

NOTES: SEE DRAWING REFERENCE(S)

1. PLACE MOUNTING CLAMP ON PIPE WITH "V" BLOCK & TEMP. SENSOR IN PLACE. CLAMP LINES MATCHING THAT OF THE PIPE CENTERLINE.
2. AFTER INSTALLING MTC, CLAMP, SCREEN TEMP. SENSOR IN PLACE (HAND TIGHT IS SUFFICIENT) SECURE WITH JAW NUT.
3. DO NOT INSTALL OR REMOVE, MAINTAIN CLAMP WHILE TEMP. SENSOR IS IN PLACE.
4. TEMPERATURE SENSORS ARE SUPPLIED IN PAIRS (APPLICATIONS OR SINGLE (PIN ON ITS) FOR TEMPERATURE COMPENSATED MASS FLOWMETER APPLICATIONS).
5. SEE APPROPRIATE COMPUTER INSTALLATION DRAWINGS FOR WIRING CONNECTION AT THE FLOW COMPUTER.

CLASS APPROVED		DO NOT SCALE THIS DRAWING UNLESS OTHERWISE SPECIFIED. DIMENSIONS ARE IN INCHES (MM) FRACTIONS DECIMALS ANGLES		CONTRACT NO.	
MATERIAL		± 1/84 ± 0.01 ± 0.30 ± 0.005 ± 0.30		DR <u>A. J.</u> DATE <u>3-28-90</u>	
FINISH		FINISH		CHK <u>[Signature]</u> DATE <u>3-30-90</u>	
NEXT ASSY		NEXT ASSY		PRD <u>[Signature]</u> DATE <u>3/2/91</u>	
USED ON		USED ON		APPRO. DATE <u>3/2/91</u>	
APPLICATION		APPLICATION		CERTIFIED	
DATE		DATE		DATE	

ENTROTRON CORPORATION
HAUPPAUGE, LONG ISLAND, N.Y.

INSTALLATION/OUTLINE
991T TEMPERATURE SENSOR
PIPE/TUBE O.D. RANGE: 1/2" - 2"

SIZE CODE IDENT NO. **C 21614** 991TP-7A

SCALE 1/2" WT. 1 SHEET OF 1

ER-857,3140

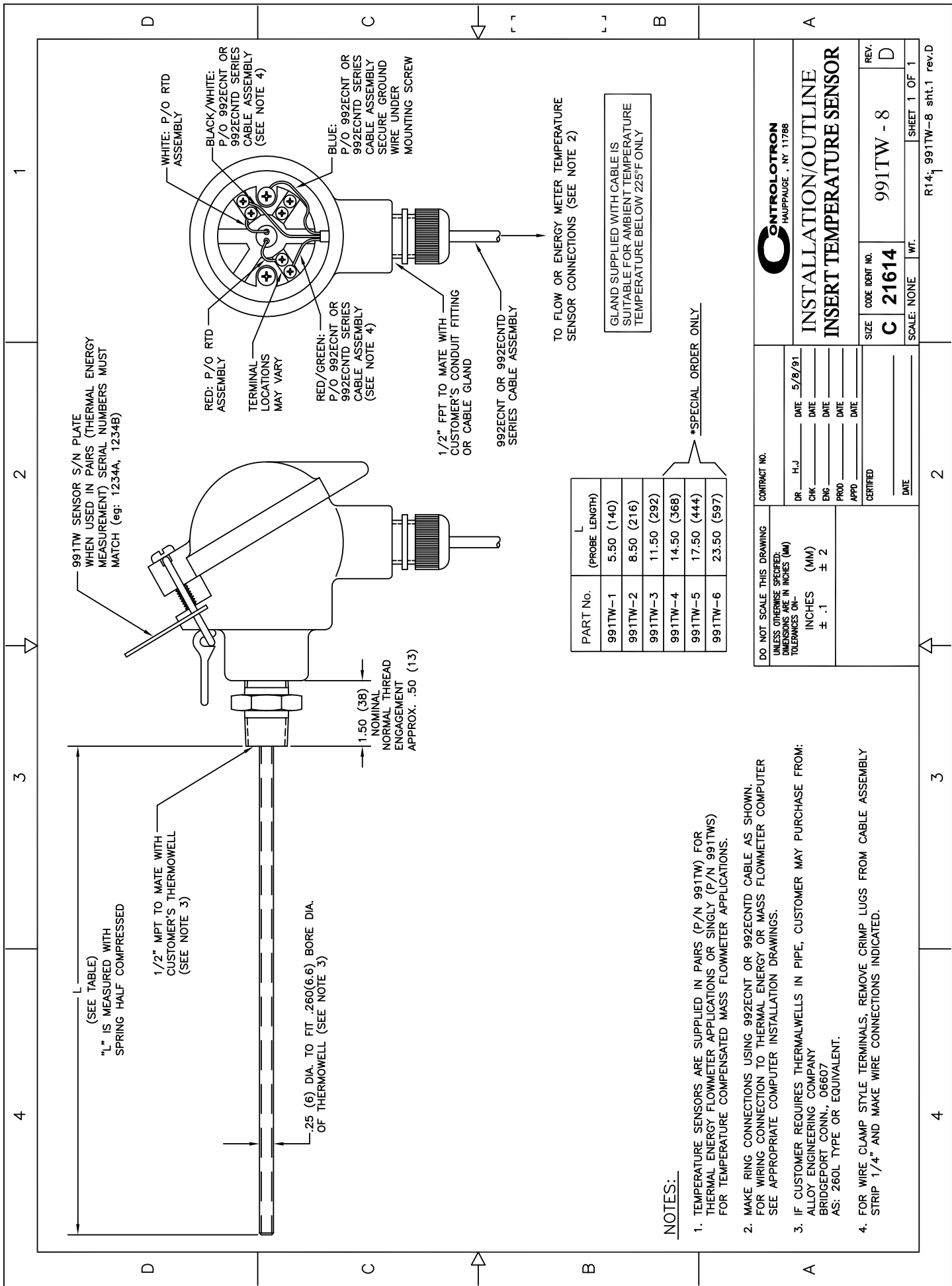

PART No.	L (PROBE LENGTH)
991TW-1	5.50 (140)
991TW-2	8.50 (216)
991TW-3	11.50 (292)
991TW-4	14.50 (368)
991TW-5	17.50 (444)
991TW-6	23.50 (597)

NOTES:

- TEMPERATURE SENSORS ARE SUPPLIED IN PAIRS (P/N 991TW) FOR THERMAL ENERGY FLOWMETER APPLICATIONS OR SINGLY (P/N 991TWS) FOR TEMPERATURE COMPENSATED MASS FLOWMETER APPLICATIONS.
- MAKE RING CONNECTIONS USING 992ECNT OR 992ECNTD CABLE AS SHOWN. FOR WIRING CONNECTION TO THERMAL ENERGY OR MASS FLOWMETER COMPUTER SEE APPROPRIATE COMPUTER INSTALLATION DRAWINGS.
- IF CUSTOMER REQUIRES THERMOWELLS IN PIPE, CUSTOMER MAY PURCHASE FROM: ALLOY ENGINEERING COMPANY BRIDGEPORT CONN., 06607 AS: 260L TYPE OR EQUIVALENT.
- FOR WIRE CLAMP STYLE TERMINALS, REMOVE CRIMP LUGS FROM CABLE ASSEMBLY STRIP 1/4" AND MAKE WIRE CONNECTIONS INDICATED.

CONTROLTRON
HAUPPAUGE, N.Y. 11788

**INSTALLATION/OUTLINE
INSERT TEMPERATURE SENSOR**

DO NOT SCALE THIS DRAWING
UNLESS OTHERWISE SPECIFIED:
DIMENSIONS ARE IN INCHES (MM)
INCHES (MM)
± .1 ± .2

CONTRACT NO. _____
DR. H.J. DATE 5/9/91
CHK. DATE _____
ENG. DATE _____
PROD. DATE _____
APPD. DATE _____
CERTIFIED _____
DATE _____

SIZE: C 21614
CODE IDENT NO. 991TW - 8
SCALE: NONE WT. REV. D

SHEET 1 OF 1
R14; 991TW-8 sht.1 rev.D

STAINLESS STEEL, HASTELLOY "C" & TITANIUM PIPE

Sched.	Size	1/2	3/4	1	1 1/4	1 1/2	2	2 1/2	3	3 1/2	4	5	6	8	10	12	14	16	18	20	22	24	
5S	O.D.	0.840	1.050	1.315	1.660	1.900	2.375	2.875	3.500	4.000	4.500	5.563	6.625	8.625	10.750	12.750	14.000	16.000	18.000	20.000	22.000	24.000	
	I.D.	0.710	0.920	1.185	1.530	1.770	2.245	2.709	3.334	3.834	4.334	5.345	6.407	8.407	10.482	12.438	13.688	15.670	17.670	19.634	21.624	23.563	
	Wall	0.065	0.065	0.065	0.065	0.065	0.083	0.083	0.083	0.083	0.083	0.109	0.109	0.109	0.134	0.156	0.156	0.165	0.165	0.188	0.188	0.218	
10S	I.D.	0.674	0.884	1.097	1.442	1.682	2.157	2.635	3.260	3.760	4.260	5.295	6.357	8.329	10.420	12.390	13.624	15.624	17.624	19.564	21.564	23.500	
	Wall	0.083	0.083	0.109	0.109	0.109	0.120	0.120	0.120	0.120	0.120	0.134	0.134	0.148	0.165	0.180	0.188	0.188	0.188	0.218	0.218	0.250	
	I.D.	0.622	0.824	1.049	1.380	1.610	2.067	2.469	3.068	3.548	4.026	5.047	6.065	7.981	10.020	12.000							
40S	Wall	0.109	0.113	0.133	0.140	0.145	0.154	0.203	0.216	0.226	0.237	0.258	0.280	0.322	0.365	0.375							
	I.D.	0.546	0.742	0.957	1.278	1.500	1.939	2.323	2.900	3.364	3.826	4.813	5.761	7.625	9.750	11.750	13.000	15.000	17.000	19.000	21.000	23.000	25.000
	Wall	0.147	0.154	0.179	0.191	0.200	0.218	0.276	0.300	0.318	0.337	0.375	0.432	0.500	0.500	0.500	0.500	0.500	0.500	0.500	0.500	0.500	0.500
80S	I.D.	0.252	0.434	0.599	0.896	1.100	1.503	1.771	2.300	2.728	3.152	4.063	4.897	6.875	8.750	10.750							
	Wall	0.294	0.308	0.358	0.400	0.436	0.552	0.600	0.636	0.674	0.750	0.864	0.875	1.000	1.000								
	I.D.																						

CARBON STEEL and PVC PIPE

Pipe	Size	1/2	3/4	1	1 1/4	1 1/2	2	2 1/2	3	3 1/2	4	5	6	8	10	12	14	16	18	20	22	24	26	28	30	32	34	36	42
Standard	O.D.	0.840	1.050	1.315	1.660	1.900	2.375	2.875	3.500	4.000	4.500	5.563	6.625	8.625	10.750	12.750	14.000	16.000	18.000	20.000	22.000	24.000	26.000	28.000	30.000	32.000	34.000	36.000	42.000
	I.D.	0.622	0.824	1.049	1.380	1.610	2.067	2.469	3.068	3.548	4.026	5.047	6.065	7.981	10.020	12.000	13.250	15.250	17.250	19.250	21.250	23.250	25.250	27.250	29.250	31.250	33.250	35.250	41.250
	Wall	0.109	0.113	0.133	0.140	0.145	0.203	0.216	0.226	0.237	0.258	0.280	0.322	0.365	0.375	0.375	0.375	0.375	0.375	0.375	0.375	0.375	0.375	0.375	0.375	0.375	0.375	0.375	0.375
Extra Strong (XS)	I.D.	0.546	0.742	0.957	1.278	1.500	1.939	2.323	2.900	3.364	3.826	4.813	5.761	7.625	9.750	11.750	13.000	15.000	17.000	19.000	21.000	23.000	25.000	27.000	29.000	31.000	33.000	35.000	41.000
	Wall	0.147	0.154	0.179	0.191	0.200	0.218	0.276	0.300	0.318	0.337	0.375	0.432	0.500	0.500	0.500	0.500	0.500	0.500	0.500	0.500	0.500	0.500	0.500	0.500	0.500	0.500	0.500	0.500
	I.D.	0.252	0.434	0.599	0.896	1.100	1.503	1.771	2.300	2.728	3.152	4.063	4.897	6.875	8.750	10.750													
Double Extra (XXS)	Wall	0.294	0.308	0.358	0.400	0.436	0.552	0.600	0.636	0.674	0.750	0.864	0.875	1.000	1.000														
	I.D.																												
	Wall																												
Sched. 10	I.D.																												
	Wall																												
	I.D.																												
Sched. 20	I.D.																												
	Wall																												
	I.D.																												
Sched. 30	I.D.																												
	Wall																												
	I.D.																												
Sched. 40	I.D.																												
	Wall																												
	I.D.																												
Sched. 60	I.D.																												
	Wall																												
	I.D.																												
Sched. 80	I.D.																												
	Wall																												
	I.D.																												
Sched. 100	I.D.																												
	Wall																												
	I.D.																												
Sched. 120	I.D.																												
	Wall																												
	I.D.																												
Sched. 140	I.D.																												
	Wall																												
	I.D.																												
Sched. 160	I.D.																												
	Wall																												
	I.D.																												

NON-STANDARD CARBON

Size	10	20	24
O.D.	10.750	20.000	24.000
I.D.	10.192	19.375	23.375
Wall	0.279	0.312	0.312

The above sizes are produced by pipe mills but dimensions do not conform to any regular standard or schedule.

- △ These materials are generally available in Schedules 40 and 80 only.
- ◇ Wall Thickness of Schedule 5S & 10S does not permit threading in accordance with the American Standard for Pipe Threads (ASA No. B2.1)
- ⊗ Wall thickness identical with thickness of "Standard Weight" pipe.
- ▲ Wall Thickness identical with thickness of "Extra-Heavy" pipe.
- * These do not conform to American Standard B36. 10.

PIPE WEIGHT FORMULA FOR STEEL PIPE (lbs per foot)
10.68 (D-t), where D=Outside Diameter and t=Wall Thickness



Siemens Industry Inc.
 Industry Automation Division
 Coc Ultrasonic Flow
 Hauppauge, New York 11788 USA
 Web: www.usa.siemens.com

Sonic Velocity Relative to Temperature of Pure Water								
Temperature		Velocity M/S	Temperature		Velocity M/S	Temperature		Velocity M/S
°F	°C		°F	°C		°F	°C	
0.0	-17.8	1292.45	100.0	37.8	1525.03	200.0	93.3	1548.38
2.0	-16.67	1300.64	102.0	38.9	1526.99	202.0	94.4	1547.60
4.0	-15.55	1308.63	104.0	40.0	1528.86	204.0	95.6	1546.78
6.0	-14.44	1316.44	106.0	41.1	1530.67	206.0	96.7	1547.60
8.0	-13.33	1324.06	108.0	42.2	1532.4	208.0	97.8	1545.02
10.0	-12.22	1331.50	110.0	43.3	1534.06	210.0	98.9	1544.08
12.0	-11.00	1338.77	112.0	44.4	1535.64	212.0	100.0	1543.11
14.0	-10.0	1345.86	114.0	45.6	1537.16	214.0	101.1	1542.10
16.0	-8.89	1352.78	116.0	46.7	1538.61	216.0	102.2	1541.05
18.0	-7.78	1359.53	118.0	47.8	1539.99	218.0	103.3	1539.97
20.0	-6.67	1366.12	120.0	48.9	1541.30	220.0	104.4	1538.85
22.0	-5.56	1372.55	122.0	50.0	1542.55	222.0	105.6	1537.70
24.0	-4.44	1378.82	124.0	51.1	1543.74	224.0	106.7	1536.51
26.8	-3.33	1384.94	126.0	52.2	1544.86	226.0	107.8	1535.29
28.0	-2.22	1390.90	128.0	53.3	1545.91	228.0	108.9	1534.03
30.0	-1.11	1396.72	130.0	54.4	1546.91	230.0	110.0	1532.74
32.0	0.0	1402.39	132.0	55.6	1547.84	232.0	111.1	1531.42
34.0	1.11	1407.91	134.0	56.7	1548.72	234.0	112.2	1530.06
36.0	2.22	1413.30	136.0	57.8	1549.53	236.0	113.3	1528.67
38.0	3.33	1418.55	138.0	58.9	1550.29	238.0	114.4	1527.26
40.0	4.44	1423.66	140.0	60.0	1550.99	240.0	115.6	1525.81
42.0	5.56	1428.64	142.0	61.1	1551.63	242.0	116.7	1524.33
44.0	6.67	1433.48	144.0	62.2	1552.21	244.0	117.8	1522.83
46.0	7.78	1438.20	146.0	63.3	1552.74	246.0	118.9	1521.29
48.0	8.89	1442.80	148.0	64.4	1553.22	248.0	120.0	1519.73
50.0	10.0	1447.27	150.0	65.6	1553.64	250.0	121.1	1518.14
52.0	11.11	1451.62	152.0	66.7	1554.01	260.0	126.7	1507.00
54.0	12.22	1455.85	154.0	67.8	1554.32	270.0	132.2	1497.00
56.0	13.33	1459.97	156.0	68.9	1554.59	280.0	137.8	1487.00
58.0	14.44	1463.97	158.0	70.0	1554.80	290.0	143.3	1476.00
60.0	15.56	1467.86	160.0	71.1	1554.98	300.0	148.9	1465.00
62.0	16.67	1471.64	162.0	72.2	1555.07	310.0	154.4	1453.00
64.0	17.78	1475.31	164.0	73.3	1555.13	320.0	160.0	1440.00
66.0	18.89	1478.88	166.0	74.4	1555.15	330.0	165.6	1426.00
68.0	20.0	1482.34	168.0	75.6	1555.11	340.0	171.1	1412.00
70.0	21.1	1485.70	170.0	76.7	1555.03	350.0	176.7	1398.00
72.0	22.2	1488.96	172.0	77.8	1554.90	360.0	182.2	1383.00
74.0	23.3	1492.13	174.0	78.9	1554.72	370.0	187.8	1368.00
76.0	24.4	1495.19	176.0	80.0	1554.49	380.0	193.3	1353.00
78.0	25.6	1498.16	178.0	81.1	1554.22	390.0	198.9	1337.00
80.0	26.7	1501.04	180.0	82.2	1553.91	400.0	204.4	1320.00
82.0	27.8	1503.82	182.0	83.3	1553.55	410.0	210.0	1302.00
84.0	28.9	1506.52	184.0	84.4	1553.14	420.0	215.6	1283.00
86.0	30.0	1509.13	186.0	85.6	1552.70	430.0	221.1	1264.00
88.0	31.1	1511.65	188.0	86.7	1552.21	440.0	226.7	1244.00
90.0	32.2	1514.08	190.0	87.8	1551.67	450.0	232.2	1220.00
92.0	33.3	1516.44	192.0	88.9	1551.10	460.0	237.8	1200.00
94.0	34.4	1518.70	194.0	90.0	1550.48	470.0	243.3	1180.00
96.0	35.6	1520.89	196.0	91.1	1549.82	480.0	248.9	1160.00
98.0	36.7	1523.00	198.0	92.2	1549.12	490.0	254.4	1140.00

Ethylene Glycol

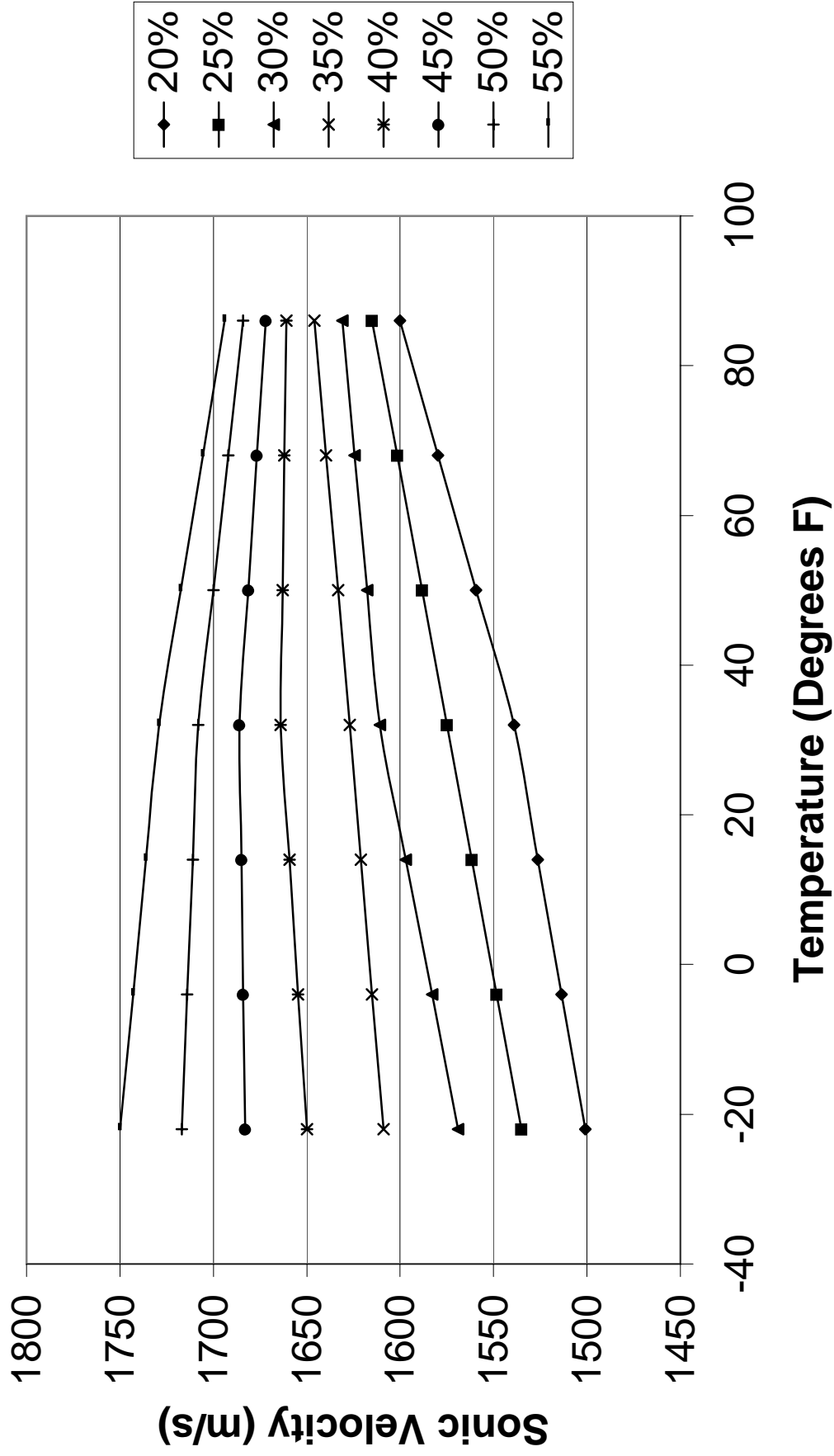

Glossary

Active Memory

Section of RAM allocated for active site parameters (all current values). The flow meter receives site-specific operating instructions from Active Memory.

Alphanumeric Field

An 8-character data entry field that allows you to specify a Site Name or a Security code.

Arrow Keys

Use the <Up, Down, Left and Right> Arrows to navigate through the Installation Menu in their respective directions. The <Up or Down> Arrows allow you also to scroll through option list items.

Asterisk

Refers to the marker used in the Installation Menu to indicate a current option list selection. When you access an option list, you can move the asterisk with the <Up or Down> Arrows to a new selection, then press <ENTER> to select the item.

CLR (Clear) Key

Use the <CLR> key to erase a numeric value or clear a selection from a multiple select option list.

Cursor

This refers to the highlighted text and the arrow cursor that you move via the arrow direction when navigating through menus or menu cells.

Data Entry

Refers to data entered into a menu cell (either numeric or option list selection).

Datalogger Memory

Memory segment that stores data items logged during operation. You can view the Datalogger contents either on-screen or transmit it to an external device via the RS-232 serial port. The amount of Datalogger memory depends on how many sites reside in Site Storage memory.

ENTER Key

Use the <ENTER> key to store a current numeric value or option list item.

Flow Meter

Refers to the flow meter itself (the transmitter and sensors combined).

Graphic Screen

Refers to the integral LCD display screen.

Initial Makeup

An internal process performed during installation, where the flow meter acquires its receive signal and enhances other parameters for optimal operation at a site.

In-process Makeup

An internal process where the flow meter recovers its Initial Makeup parameters after a fault condition interrupts operation.

Installation Menu

The flow meter's overall menu structure. It allows you to define all aspects of operation for the flow meter.

Interface m/s

Refers to an alarm function that declares the passage of a liquid or gas interface by a comparison analysis of the relative sonic velocities of the two liquids or two gases.

LAPTOT

Refers to a system function that freezes the Totalizer display, while the Totalizer continues to update its registers.

Local Display

Refers to the transmitter integral display screen.

Menu

Sub-sections of the Installation Menu that allow you to define specific operational functions (e.g., RS-232 Setup).

Menu Cell

A location within a menu where you can define either a single numeric value or option list selection that supports the Sub-Menu's function. Certain view-only menu cells show reference data appropriate to the current application.

NEGFLOW

Totalizer mode for negative flow total only.

NETFLOW

Totalizer mode that combines positive and negative flow totals.

NOTOT

System function that disables the internal Totalizer.

Number Index

Computed sensor spacing index based on the estimated sonic velocity measurement. This Index can not be overridden by installer.

Numeric Data

Refers to a value entered into a menu cell. An example would be the pipe outer diameter.

Numeric Entry

Refers to a number you type into menu cell that stores numeric data.

Numeric Keys

Use the Numeric keys to type a numeric value where appropriate.

Op Sys ROM

The Read-Only-Memory that stores the basic operating instructions and permanent defaults of the flow meter's operating system.

Option List

Lists of options presented at menu cells that allow you to select either a single item or multiple items (depending on the function that the menu cell controls).

Parameters

Refers to value (either numeric or list selection) stored in a menu cell.

POSFLOW

Totalizer mode for positive flow total only.

Register

Refers to a memory location used by the flow meter to store data such as the flow total, etc.

RTD

Resistive Temperature Device. Temperature sensors used with energy flow of mass flow systems.

Sensor

Refers to entire spool piece, in some instances. Also flow sensors that the flow meter uses to measure the flow rate. Also called transducers and abbreviated as Xdcr.

Site Name

A user-entered name that the flow meter associates with a stored Site Setup. You retrieve a particular Site by selecting its name from a site name list.

Site Setup

A collection of parameters used by the flow meter to service a specific site (or location). The flow meter allows you to store several independent Site Setups.

Site Storage Memory

Section of RAM allocated for permanent data storage. This memory segment stores inactive site setups (including a backup of active site). The flow meter's Site Setup storage capacity depends on the dynamic memory allocation as dictated by each application. In addition, the flow meter uses Site Storage Memory to store configurable operating parameters such as pipe, liquid or gas tables.

Si-Ware

Siemens software program that interfaces with Siemens flow meters to assess flow meter installation conditions and to collect data for comparison with prior baseline data.

Spacing Index

Refers to the Number Index used by the flow meter to determine the space between the upstream and downstream sensors on clamp-on systems.

Spacing Offset

Fixed sensor offset assigned by the flow meter. This can be overridden by the installer.

TOTCNT

A Totalizer pulse count function used for Batching or Sampling.

Transducer

Also known as sensor.

Vaer

The flow meter's aeration percent output.

Vps

The sonic propagation velocity of a pipe.

Vs

The sonic velocity of a liquid or gas.

Index

1

- 1012T Sensor Mounting Tracks
 - Direct Mount, 57
 - Reflect Mount, 54

A

- AC Power
 - Power Adapter/Charger, 29
- Actual MTY Command, 70
- Actual Zero, 64
- Alarms
 - Empty Pipe Set, 70
 - Letter Codes, 121
- Analog Input Setup, 98
- Analog Out Setup, 95
 - Io Output, 96
 - Pgen Output, 97
 - Vo Output, 97
- Analog Out Trim, 103
 - Current Output Trim, 104
 - Pgen Output Trim, 106
 - Voltage Output Trim, 105
- AutoZero, 63

B

- Basic Requirements, 24
- Battery Operation, 27
- Battery Pack
 - Removal/Replacement, 123

C

- CE marked equipment, 13
- CE-mark, 13
- Commissioning, 70
- Customer Support Hotline, 127

D

- Damping Control, 89
- Data Output Filters

- SmartSlew, Time Average, 89
- Datalogger
 - Circular Memory, 88
 - Clear Logger data, 88
 - Control menu, 86
 - Display screen setup, 87
 - Est LogTime Left, 88
 - RS-232 output, 87
- Deadband Controls, 90
- Decontamination, 128
- Device inspection, 9
- Digital Damping Control:(Hot Key 1 and 2), 135
- Digitally Coded MultiPulse, 17
- Direct Mount
 - EZ Clamp, 48

E

- Empty Pipe Set, 71
- Energy AnCal, 102
- Energy AnCal Menu, 102

F

- F4 Reset, 132
 - Clearing Active Memory, 132
 - Clearing All Saved Memory, 132
- Features, 15
- Flow meter Types, 18
 - 2-Channel, 19
 - 2-Path, 19
- Flow Profile Compensation, 18
- Flow Rate
 - Calibration Methods, 160
 - Calibration Tables, installation, 162
 - Intrinsic Calibration (factory), 160
 - Kc Calibration (Slope Correction), 161
- Flow Units
 - Selecting, 79

H

- History, 10
- Hotline, 127

I

- Installation
 - Safety instructions, 23
- Installation Menu
 - Navigating and Keypad functions, 36
- Installation Menu Chart, 73
- Installation/Outline Drawings, 163
- Internet
 - Contact person, 128
 - Support, 127
- Introduction, 9

L

- Language
 - Selecting, 38
- Liquid Class
 - Selecting, 40
- Lithium batteries
 - Safety, 14
- Location and Service
 - Selecting, 40
- Logger Control, 86
- Ltn Menu Cell, 44

M

- Maintenance, 123
- Memory Control Menu, 94
 - Defragment, 95
 - Log Memory Left, 94
 - Memory Map, 95
- Memory Delay, 91
- Memory/Fault Set, 91
- Meter Type
 - Selecting, 38
- MTYmatic Command, 72

P

- Pipe Class
 - Selecting, 39
- Pipe Configuration
 - Selecting, 41
- Power Adapter/Battery Charger
 - Power Cord Codes, 26
- Pressure
 - Safety instructions, 23

R

- Reflect Mount
 - EZ Clamp, 44
- Reflexor
 - Diagnostic Data, 118
 - Operating Mode and Installation, 109
 - Spectra Graph, 115
 - Zero/Fault Option, 92
- Reflexor Mode
 - Overview, 16
- Relays
 - Setup, 92
- Repair, 127
- Resistive Temperature Device (RTD), 106
 - Ice Bath RTD Calibration, 109
- Return procedures, 128
- ReversaMatic, 64
- RS-232 Setup, 82

S

- Safety
 - Sensor installation, 23
- Safety notes, 11
- Sensor
 - Direct Mount Installation, 48
 - Identification, 33
 - Installation, 45
 - Selection, 35
 - Typical Labels, 34
- Sensors
 - Mounting Supplies, 31
 - Preliminary Mounting Procedures, 30
 - Selection, 42
- Service,
- Set Empty Command, 72
- Site Setup Data Menu, 143
 - HF Diagnostic Menu Item, 144
- Sites
 - Creating a Site, 38
- Span Data
 - Setting, 84
- Support, 127
- Symbols, 12

T

- Test Facilities
 - Command Modes, 135
 - Graphic Screens, 133
 - Hot Key Summary, 142

Theory of Operation, 17
Totalizer Mode Controls, 81
Totalizer Modes, 80
Troubleshooting, 129
Typical Flowmeter Applications, 16
Typical Industries Serviced, 16

W

Warning symbols, 12
Wide Beam Transmission, 20
Wiring
 Input/Output, 151

Z

Zero Flow Compensation Methods, 63
ZeroMatic, 64

Get more information

www.siemens.com/flow

Siemens Industry, Inc.
Industry Automation Division
CoC Ultrasonic Flow
Hauppauge, NY 11788
USA

Subject to change without prior notice
Order No.: A5E02951524-AB
Printed in the USA
© Siemens AG 01.2013

www.siemens.com/processautomation