

SIEMENS



SITRANS F

Ultrasonic Flowmeters

SITRANS FST020 IP65 NEMA 4X - 7ME3570

Operating Instructions

Edition

2/2014

Answers for industry.

SIEMENS

SITRANS F

Ultrasonic Flowmeters FST020 IP65 NEMA 4X



Operating Instructions

<u>Introduction</u>	1
<u>Safety notes</u>	2
<u>Description</u>	3
<u>Installing/Mounting</u>	4
<u>Connecting</u>	5
<u>Commissioning</u>	6
<u>Functions</u>	7
<u>Alarm, error and system messages</u>	8
<u>Maintenance and Service</u>	9
<u>Troubleshooting</u>	10
<u>Technical data</u>	11
<u>Appendix</u>	A
<u>Appendix</u>	B

Legal information

Warning notice system

This manual contains notices you have to observe in order to ensure your personal safety, as well as to prevent damage to property. The notices referring to your personal safety are highlighted in the manual by a safety alert symbol, notices referring only to property damage have no safety alert symbol. These notices shown below are graded according to the degree of danger.

 DANGER
indicates that death or severe personal injury will result if proper precautions are not taken.
 WARNING
indicates that death or severe personal injury may result if proper precautions are not taken.
 CAUTION
indicates that minor personal injury can result if proper precautions are not taken.
NOTICE
indicates that property damage can result if proper precautions are not taken.

If more than one degree of danger is present, the warning notice representing the highest degree of danger will be used. A notice warning of injury to persons with a safety alert symbol may also include a warning relating to property damage.

Qualified Personnel

The product/system described in this documentation may be operated only by **personnel qualified** for the specific task in accordance with the relevant documentation, in particular its warning notices and safety instructions. Qualified personnel are those who, based on their training and experience, are capable of identifying risks and avoiding potential hazards when working with these products/systems.

Proper use of Siemens products

Note the following:

 WARNING
Siemens products may only be used for the applications described in the catalog and in the relevant technical documentation. If products and components from other manufacturers are used, these must be recommended or approved by Siemens. Proper transport, storage, installation, assembly, commissioning, operation and maintenance are required to ensure that the products operate safely and without any problems. The permissible ambient conditions must be complied with. The information in the relevant documentation must be observed.

Trademarks

All names identified by ® are registered trademarks of Siemens AG. The remaining trademarks in this publication may be trademarks whose use by third parties for their own purposes could violate the rights of the owner.

Disclaimer of Liability

We have reviewed the contents of this publication to ensure consistency with the hardware and software described. Since variance cannot be precluded entirely, we cannot guarantee full consistency. However, the information in this publication is reviewed regularly and any necessary corrections are included in subsequent editions.

Table of contents

1	Introduction.....	7
1.1	Preface	7
1.2	Items supplied	7
1.3	History	7
1.4	Further Information.....	8
2	Safety notes	9
2.1	General safety instructions	9
2.2	Warning Symbols	10
2.3	Laws and directives.....	11
2.4	Lithium batteries.....	12
3	Description	13
3.1	FST020 features	13
3.2	NEMA 4X Transmitters.....	13
4	Installing/Mounting.....	15
4.1	Determining a location.....	15
4.2	Use according to specifications	15
4.3	Application Guidelines	16
4.4	Mounting the Transmitter.....	17
5	Connecting	21
5.1	Transmitter Wiring.....	21
5.1.1	Connecting Power	21
5.1.2	ModBus/BACnet Setup.....	28
5.2	Navigating the Menu	30
5.3	Programming the Transmitter	32
5.4	Installing the Sensor.....	37
5.4.1	Preliminary Installation Procedures.....	37
5.4.2	Sensor Identification and Selection.....	40
5.4.3	Reflect Mount using Spacer Bar	45
5.4.4	Direct Mount.....	49
5.4.5	1012T Mounting Tracks.....	54
5.5	Sensor Wiring	63
5.5.1	Wiring the Sensors	63
6	Commissioning	65
6.1	Commissioning.....	65

6.2	Empty Pipe Set	66
6.3	Installation Menus	69
7	Functions	73
7.1	Selecting Flow Units	73
7.2	Zero Flow Adjust Menu	77
7.3	Span Data	81
7.4	Logger Control	83
7.5	Operation Adjust Menu Settings	85
7.6	Analog Out Setup	88
7.7	Setting Relays	89
7.8	Pulse Out Setup	91
7.9	Memory Control	96
7.10	Analog Output Trim	97
8	Alarm, error and system messages	101
8.1	Alarm Codes	101
8.2	Setting Alarm Levels	102
9	Maintenance and Service	107
9.1	Maintenance	107
9.2	Technical support	107
9.3	Return procedures	109
10	Troubleshooting	111
10.1	Troubleshooting	111
10.2	Force Transmit	113
10.3	System Reset	115
10.4	Site Setup Data	120
11	Technical data	125
A	Appendix	127
A.1	Certificates	127
A.2	Ordering	127
A.3	I/O Connections and Wiring	127
A.4	Flowrate Calibration	131
A.5	BACnet/ModBus Communications	135
A.5.1	Introduction	135
A.5.2	BACnet	135
A.5.3	BACnet Protocol Implementation Conformance Statement	139
A.5.4	ModBus	141

B	Appendix.....	145
	B.1 Installation/Outline Drawings	145
	Glossary.....	147
	Index	153

Tables

Table 4- 1	CQO:1012NMB-1 Mounting Kit.....	19
Table 5- 1	5-Key Touch Keypad and PC Keyboard Function Chart.....	31
Table 5- 2	Pipe Configuration Option List Definitions	36
Table 5- 3	Universal Sensor Selection Chart	42
Table 5- 4	High Precision Sensor Selection Chart	43
Table 7- 1	Totalizer Modes.....	74
Table 7- 2	Totalizer Controls	76
Table 7- 3	Logger Control Menu Option List	83
Table 7- 4	Operation Adjust Menu.....	86
Table 7- 5	Analog Outputs	88
Table 7- 6	Analog Out Setup Data Categories.....	88
Table 7- 7	Relay 1 Option List.....	90
Table 7- 8	Pulse Output Values for Gallons (US).....	96
Table 7- 9	Memory Control Menu.....	96
Table 7- 10	Analog Out Trim Menu Structure	97
Table 10- 1	Troubleshooting Tips.....	111
Table 10- 2	Site Setup Menu Items	120
Table A- 1	Part Numbers and Connection Diagrams.....	127
Table A- 2	J8 Connector.....	128
Table A- 3	J9 Connector (DB9).....	128
Table A- 4	Input/Output Wiring (TB1).....	129

Figures

Figure 3-1	Typical Transmitter Label	14
Figure 3-2	NEMA 4X Transmitter.....	14
Figure 4-1	Wall Mounting	17
Figure 4-2	Pipe Mounting	18
Figure 5-1	Input Power Wiring.....	22

Figure 5-2	Display Screen.....	25
Figure 5-3	RS-232 Serial Port Menu Screen.....	26
Figure 5-4	RS-232-Interface Cable Wiring.....	27
Figure 5-5	RS-485 Wiring Diagram.....	30
Figure 5-6	5-Key Touch Keypad.....	31
Figure 5-7	Reflect Mount (Pipe shown from above in 12 o'clock position)	37
Figure 5-8	Direct Mount (Pipe shown from above in 12 o'clock position)	38
Figure 5-9	Sensor Alignment.....	39
Figure 5-10	Pipe Surface Preparation	40
Figure 5-11	Sample Universal Sensor Label.....	41
Figure 5-12	Sample Hi Precision Sensor Label.....	42
Figure 5-13	Reflect Mount with Mounting Frames and Spacer Bar.....	45
Figure 5-14	Reflect Mount, Spacer Bar-Side View	46
Figure 5-15	Preparing the Pipe	47
Figure 5-16	Sensor	48
Figure 5-17	Sensor Installation.....	48
Figure 5-18	Mylar Spacing Guide	49
Figure 5-19	Wrap Strap Under Pipe and Attach to Adjusting Screw	50
Figure 5-20	Aligning the Sensor to the Pipe.....	51
Figure 5-21	Wrapping the Mylar Spacing Guide around the pipe (End View)	52
Figure 5-22	Finding the Halfway Distance	52
Figure 5-23	Aligning the Sensors for Direct Mode operation (End View)	53
Figure 5-24	Reflect Mount with Model 1012TN Mounting Track (Side View)	55
Figure 5-25	Direct Mount 180° opposed with Mounting Tracks	57
Figure 5-26	Wrapping the Mylar Spacing Guide around the pipe (End View)	59
Figure 5-27	Finding the Halfway Distance	59
Figure 5-28	Track Rail Alignment	60
Figure 5-29	REF and Number Index Pin Locations.....	61
Figure 5-30	Connecting Sensor Cables to Transmitter.....	63
Figure 6-1	Measuring Flow.....	66
Figure 7-1	FST020 Output Wiring Terminals	92
Figure A-1	Terminal TB1 including J8 Connector, DB9 Connector (J9), Power Connector (J12) and Menu Lockout Switch (S1).....	128
Figure A-2	Typical TB1 Wiring	130
Figure A-3	Typical FST020 BACnet Application	136

Introduction

1.1 Preface

These instructions contain all the information you need for using the device.

The instructions are aimed at persons mechanically installing the device, connecting it electronically, configuring the parameters and commissioning it as well as service and maintenance engineers.

Note

It is the responsibility of the customer that the instructions and directions provided in the manual are read, understood and followed by the relevant personnel before installing the device.

1.2 Items supplied

- SITRANS FST020 IP65 (NEMA 4X) Transmitter
- SITRANS F Literature CD

Note

For additional items refer to your packing slip.

Inspection

1. Check for mechanical damage due to possible improper handling during shipment. All claims for damage are to be made promptly to the shipper.
2. Make sure the scope of delivery, and the information on the type plate corresponds to the ordering information.

1.3 History

The contents of these instructions are regularly reviewed and corrections are included in subsequent editions. We welcome all suggestions for improvement.

The following table shows the most important changes in the documentation compared to each previous edition.

Edition	Remarks
02/2011	First Edition Operating Instructions for SITRANS FST020 IP65 NEMA 4X flow meter.
11/2011	2nd Edition Operating Instructions for SITRANS FST020 IP65 NEMA 4X flow meter.
02/2012	3rd Edition Operating Instructions for SITRANS FST020 IP65 NEMA 4X flow meter. The most important changes are as follows: <ul style="list-style-type: none"> • Sensor label and sensor selection procedure updates • Added 2mA drop fault indication note • Added DIN pipe size table 2448 reference note • Added Empty Pipe Set procedure • Updated Pulse Out Setup procedure • Updated Troubleshooting Table • Added additional Display screen instructions
02/2014	4th Edition Operating Instructions for SITRANS FST020 IP65 NEMA 4X flow meter. This document replaces all previous instructions. The most important changes are as follows: <ul style="list-style-type: none"> • Added note to use Si-Ware, download the program at [http://s13.me/ns/cv] • Added BACnet and ModBus Communication Option configuration data and operating instructions. • Replaced Installation Drawing 1011HNFS-7 Rev 02 with Revision 004. • Replaced Installation Drawing 1011NFPS-8 Rev B1 with Revision 002.

1.4 Further Information

Product information on the Internet

The Operating Instructions are available on the CD-ROM shipped with the device and on the Internet on the Siemens homepage, where further information on the range of SITRANS F flow meters may also be found: Product information on SITRANS F in the Internet (<http://www.siemens.com/sitransf>)

Worldwide contact person

If you need more information or have particular problems not covered sufficiently by the operating instructions, please get in touch with your contact person. You can find contact information for your local contact person on the Internet: www.siemens.com Local contact person (<http://www.automation.siemens.com/partner>)

Safety notes

2.1 General safety instructions









NOTICE
Correct, reliable operation of the product requires proper transport, storage, positioning and assembly as well as careful operation and maintenance.
Only qualified personnel should install or operate this instrument.

Note

Alterations to the product, including opening or improper repairs of the product, are not permitted.

If this requirement is not observed, the CE mark and the manufacturer's warranty will expire.

2.2 Warning Symbols

Symbol	Explanation
	Consult operating instructions
	Hot surface
	Dangerous electrical voltage
	Corrosive materials
	Toxic materials
	Isolate the device from power using a circuit-breaker
	Protect the device from impact otherwise loss of degree of protection
	Protective insulation; device in protection class II

2.3 Laws and directives

General requirements

Installation of the equipment must comply with national regulations. For example, the National Electrical Codes.

Instrument safety standards

The device has been tested at the factory, based on the safety requirements. In order to maintain this condition over the expected life of the device the requirements described in these Operating Instructions must be observed.

NOTICE
Material compatibility
Siemens can provide assistance with the selection of sensor parts. However, the full responsibility for the selection rests with the customer and Siemens can take no responsibility for any failure due to material incompatibility.

CE marked equipment

The CE-mark symbolizes the compliance of the device with the following Directives:

- EMC-Directive 2004/108/EC
- Low Voltage Directive 2006/95/EC

2.4 Lithium batteries

Lithium batteries are primary power sources with high energy content designed to represent the highest possible degree of safety.

 **WARNING**

Potential hazard

Lithium batteries may present an Explosion Hazard if they are abused electrically or mechanically. This is in most circumstances associated with the generation of excessive heat where internal pressure may cause the cell to rupture.

Thus the following basic precautions should be observed when handling and using lithium batteries:

- Do not short-circuit, recharge or connect with false polarity.
- Do not expose to temperature beyond the specified temperature range or incinerate the battery.
- Do not crush, puncture or open cells or disassemble battery packs.
- Do not weld or solder to the battery's body.
- Do not expose contents to water.

Description

3.1 FST020 features

Description

The Siemens SITRANS FST020 IP65 NEMA 4X flow meters achieve highly accurate flow measurement owing to the WideBeam ultrasonic transit-time technology. The sensors are mounted on the outside of the pipe, preventing contact with the medium.

The sensor construction makes installation and commissioning of even the largest sizes very straight forward and easy. The sensors deliver true multi parameter measurements i.e. volume flow.

Note

This Operating Instructions manual applies to the following FST020 IP65 NEMA 4X operating systems: Version 2.04.04 and later.

3.2 NEMA 4X Transmitters

SITRANS FST020 Transmitters

The SITRANS FST020 NEMA 4X series transmitters are available in AC or DC powered versions. The transmitters include an LCD display providing flow rate, diagnostics data and keypad interface to access on-screen software setup menus.

SITRANS FST020 NEMA 4X Transmitter Labels

The transmitter label is located on the top of the unit. The illustration shows a typical label but labels vary depending upon model and installation location.

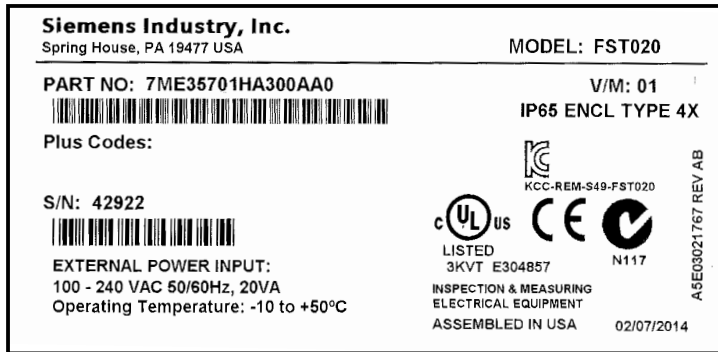

Figure 3-1 Typical Transmitter Label

SITRANS FST020 Model Numbers

The SITRANS FST020 NEMA 4X model numbers:

- Single Channel - 7ME35701HA300xx0 (AC power)
- Single Channel - 7ME35701HB300xx0 (DC power)

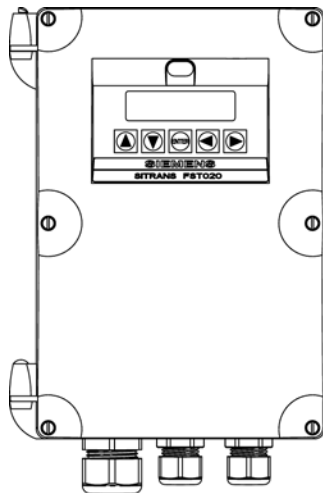



Figure 3-2 NEMA 4X Transmitter

Installing/Mounting

4.1 Determining a location

 WARNING
Electrical Shock Hazard
May cause death or serious personal injury.
Disconnect power before working on this product.

Upstream / Downstream

- Avoid long drop lines downstream from the sensor to prevent the meter pipe from draining.
- Avoid installing the sensor upstream of a free discharge in a drop line where possible.

Sensor Location in piping system

The optimum location in the system depends on the application

- For liquid applications the presence of excessive gas or air bubbles in the fluid may result in erroneous measurements. Therefore, it is preferred not to install the sensor at the highest point in the system, where gas / air bubbles will be trapped. For liquids it is advantageous to install the sensor in low pipeline sections, at the bottom of a U-section in the pipeline.

4.2 Use according to specifications

"Use according to specifications" covers:

- Use within technical limits.
- Consideration of liquid specifications and references.
- Consideration of specifications as to installation, commissioning and maintenance.

Do NOT:

- Use the sensors as a footboard for installation purposes.
- Change the flow meter in any way. For e.g. decomposition of material in connection with processing, welding and use of accessories and spare parts not approved by Siemens.

Note

If the flowmeter is not used according to the specifications, the manufacturer cannot be held responsible for any resulting damage.

4.3 Application Guidelines

Basic Requirements

- Determine pipe material and dimensions.
- Avoid vertical pipes flowing in a downward direction.
- Avoid installation of sensors on the top and bottom of horizontal pipes, where possible.
- Select a location with the longest straight run of pipe.
- Identify upstream piping configuration (elbow, reducer, etc.).
- Pipe surface should be smooth and, if necessary, free of dirt and grease.
- Avoid pressure reduction components upstream, where possible.
- Avoid mounting on or near weld seams.
- Pipe must be full during set-up.

4.4 Mounting the Transmitter

⚠ WARNING

Hazardous Voltage

May cause death or serious personal injury.

Disconnect power before working on this product.

Wall Mounting

The transmitter can be mounted on any wall surface including wood, metal or concrete. Use the appropriate bolts and screws as needed for your mounting application and adhere to local codes.

- Recommended mounting: directly to wall or to electrical cabinet back panel.
- If alternate mounting surface is used it **MUST** support four times the weight of the unit.

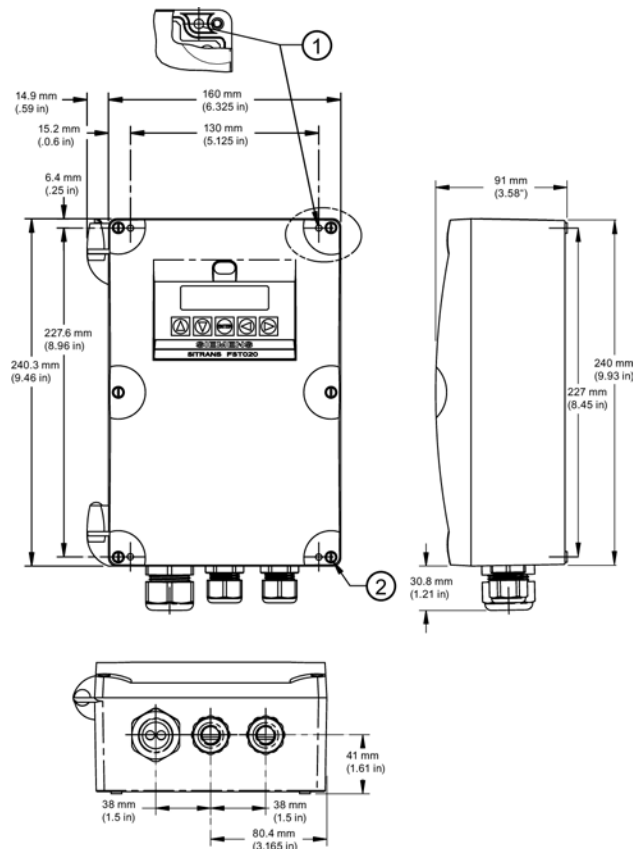

- ① Mounting holes
- ② Enclosure cover screws

Figure 4-1 Wall Mounting

Mounting the Enclosure

1. Loosen the Enclosure cover screws and open the cover to reveal the mounting screw holes.
2. Mark and drill four holes in the mounting surface for the four #8 screws (supplied).
3. Fasten with a long flat-blade screwdriver.

Pipe Mounting

For installation on 2-inch standpipe use Pipe Mounting Kit COO:1012NMB-1 (optional - see catalog). See figure below.

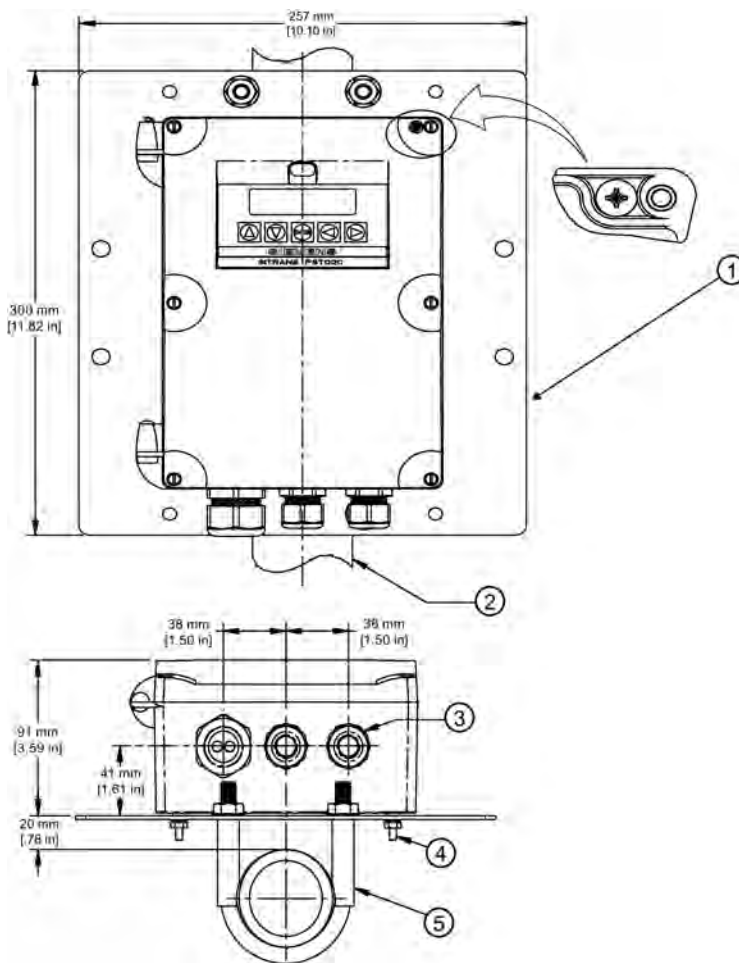

- | | |
|--|---------------------------------------|
| ① Mounting Plate | ④ Mounting Hardware (see table below) |
| ② 2 1/4" (57.1mm) to 2 3/8" (60.3mm) O.D standpipe | ⑤ U-Bolt Assembly (see table below) |
| ③ Cable Entry Ports | |

Figure 4-2 Pipe Mounting

Table 4- 1 CQO:1012NMB-1 Mounting Kit

Description	Qty
Mounting Plate	1
U-Bolt Assembly including Bracket & Nuts	2
8-32 x 5/8 LG Cross Round Head screws	4
#8 Flat Washer	4
#8 Split Lock Washers	4
8-32 Hex Nut	4

Pipe Mounting Installation

1. Affix Mounting Plate to standpipe using the U-bolt assemblies.
2. Secure transmitter to Mounting Plate using #8-32 screws, washers and nuts.
3. Refer to Connecting Power (Page 21) and Sensor Installation (Page 37) to complete installation.

Note

Use conduit fittings or cable glands on all cables.

Connecting

5.1 Transmitter Wiring

5.1.1 Connecting Power

Note

If the transmitter is not already mounted and cabling has not been run, proceed to Mounting the Transmitter (Page 17) before connecting power.

 DANGER**Hazardous Voltage**

Will cause death or serious personal injury.

Disconnect power before working on this product.

1. Using a flat-head screwdriver, loosen the six securing screws from the Keypad Enclosure Cover and open cover.
2. To determine type of power connection refer to the following part numbers:
 - 7ME3570-1HA3 = AC Power
 - 7ME3570-1HB3 = DC Power

Note

The product nameplate also lists the actual power that can be applied to the unit.

3. Pull either the AC or DC wires through transmitter case cable gland and into the transmitter case before wiring power connector.

NOTICE
Do not use a screwdriver to pry up the Display board connector (circled in the figure below).
Damage to the unit may occur.

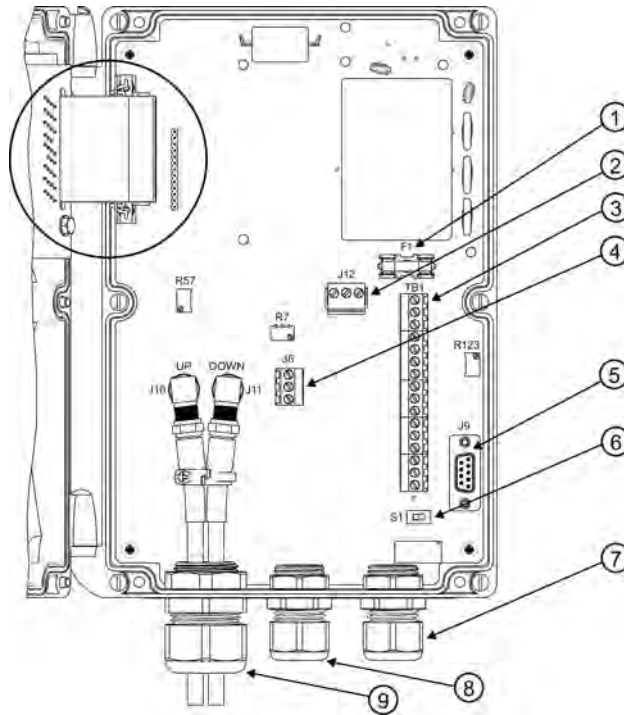

- | | |
|---|---|
| ① Fuse F1 Type GMA, 2A | ⑤ J9 RS-232 Port DB9 Connector - 15m (50 ft) max length |
| ② Input Power Connector P12 | ⑥ S1 Keypad Enable Switch |
| ③ I/O Terminals TB1 | ⑦ I/O Input Cables - 30m (98 ft) max length |
| ④ J8 RS-485 Port Connector - 30m (98 ft) max length | ⑧ Input Power Cables |
| | ⑨ Sensor Cables - 90m (300 ft) max length |

Figure 5-1 Input Power Wiring

Note

Refer to figure above, callouts ④, ⑤, ⑦ and ⑨.

Maximum cable lengths cited may be extended with factory approval, if necessary.

4. Locate power plug P12 and loosen P12 connector screws.

5. As per local electric codes, wire input power connector P12 for AC or DC power depending on power supply provided.

Connector P12	AC	DC	Wire Color
1	L1	POS +	Black
2	L2/N	NEG -	White
3	GND	GND	Green

Note

Dress cables and make sure cable length is not excessive as to impede proper replacement of access cover.

6. Insert AC or DC power wires into wire entry holes and secure by tightening wire clamp screws.

Note

Power supply connector wires should be stripped stranded or solid conductors AWG 12 - 18.

7. Pull sensor cables through transmitter case cable gland and connect to the appropriate UP and DOWN sensor connectors.
8. Connect the power cables to the appropriate power source (100-240 VAC @ 50/60 Hz or 11.5-28.5 VDC) and power up unit.

 WARNING
--

Circuit limited to 20 Amps

The branch circuit must be limited to 20A or damage to the unit and personnel injury will result.

It is recommended that the circuit breaker be located near the transmitter.

 DANGER

Shock Hazard

Will cause death or serious personal injury.
--

Disable power before servicing fuse F1.

9. If unit is operational, turn power off, close Keypad Enclosure Cover and secure the six cover screws (torque to 6 in-lbs).

Note

Do not position the transmitter in such a way that it is difficult to operate the circuit breaker or the disconnection device.

10. Turn power on. Within 10 seconds of power-up the transmitter 2-line LCD display screen will appear.

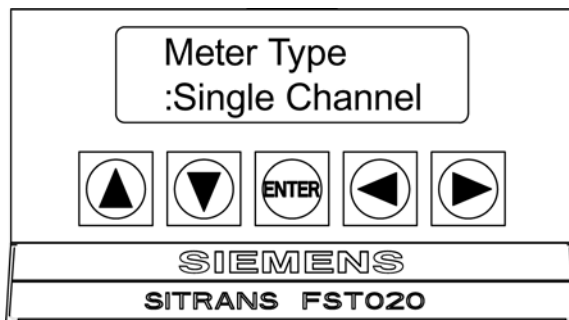

① Power-up 2-Line LCD Display Screen

Display Screen Activation

At power-up the FST020 display screen will display one of the following:

- The scrolling Siemens Welcome Screen (i.e., if no channel had been previously activated), or
- The active channel's last data screen displayed prior to turning off the instrument.

The alphanumeric LCD display screen of the FST020 provides visual access to all system variables and conditions. During initial power-up the 2 x 16 character alphanumeric display only allows access to the numerous installation menus offered by the FST020 system. Once a measurement channel is activated and begins operation it can display a wide variety of meter data.

After successful channel installation, use the Keypad and repeatedly press the <Left Arrow> until the display indicates flow data.

Note

Repeatedly press the <Left Arrow> key from any location within the Installation Menus to return to the flow display.

When satisfied with the item currently displayed, stop scrolling and use the <Right Arrow> key to move to the other display line. Once the display is set up in the desired configuration, execute no further commands and the selection cursor will eventually turn off.

Note

The System Menu can be invoked at any time by pressing the <ENTER> key.

Serial Interface Display

The data menu displays provided via the FST020 serial interface mimic the more complex SITRANS F 1010 graphic displays. Display and data item selection in these menus are accessed via the <Up/Down Arrow> keys only.

Note

The 2 x 16 alphanumeric display is not available via the serial port.

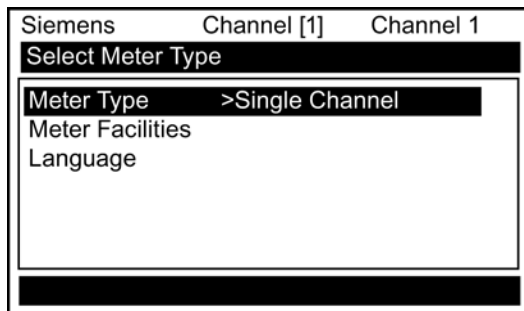

Figure 5-3 RS-232 Serial Port Menu Screen

Communications and Programming via the RS-232 Interface (optional)

To use the RS-232 Interface to program the transmitter instead of using the main unit display you must be familiar with the basics of the Windows HyperTerminal communications program or Siemens Si-Ware (download program at: <http://s13.me/ns/cv>). Most PC computers provide at least one serial port using a 9-pin D-type connector. The port designation can be either COM 1 or COM 2. **(See Quick Terminal Mode Setup procedure below.)**

1. Referring to the schematic below, wire the RS-232 Interface cable.

Note

Many newer Laptop PCs are not equipped with serial ports, having USB ports only. These PCs will require a USB RS-232 adapter that can be purchased commercially.

2. Connect the cable between the transmitter and the PC using a 9-pin or USB-to-RS-232 cable connector, depending upon the port's architecture.
3. Refer to the Commissioning (Page 65) section for details for accessing the Installation Menu.

RS-232 Interface Cable to PC RS-232 DB9 Connector

The figure below is the schematic of the serial interface cable (MLFB P/N 7ME39604CS00) needed to make the physical connection between the transmitter and your PC. Note that the connector has CTS pin shorted to the RTS pin (pins 7 and 8).

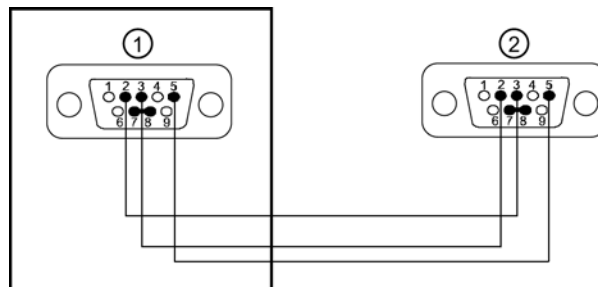

- ① 9-Pin Serial Connector (FST020)
Pin 2 - Red
Pin 3 - White
Pin 5 - Black
- ② 9-Pin solder side (PC)

Figure 5-4 RS-232-Interface Cable Wiring

Quick Terminal Mode Setup

1. Access Si-Ware (download program at: <http://s13.me/ns/cv>) or, if using [HyperTerminal], then select [HyperTerminal.exe].
2. In [Connection Description] dialog box, enter a connection name (e.g. FST020). Click [OK].
3. In [Phone Number] dialog box, select [Direct to COM 1 (or COM 2)]. Click [OK] to select.
4. In [Properties] dialog box, enter RS-232 parameters. Click [OK].
5. At terminal screen, click [File]. Select [Properties].
6. Select [Settings] tab. At [Emulation] box, select [VT-100].
7. Select [ASCII Setup]. In [ASCII Sending] uncheck boxes. In [ASCII Receiving] check [Append line feeds to incoming line ends.]. Click [OK].
8. At Terminal screen, type: Menu. Press <ENTER> to access Installation Menu.

5.1.2 ModBus/BACnet Setup

Introduction

Enter the FST020 configuration mode using either the display panel controls on the flow meter or via an RS-232 interface. The following configuration procedures are detailed in the programming section of the standard FST020 Operating Instructions.

BACnet

Select

[Meter Facilities] >>RS-485 Setup >>Protocol: *BACnet*

Under BACnet Protocol enter the following:

1. Baud Rate: *300, 1200, 2400, 4800, 9600, 38,00 (9600 is default)*
2. Address: *1-254* (devices on each RS-485 network should be limited for best communication update times e.g. <10)
3. Device Number: *1- 4194300* (must be unique system wide)
4. Network Number: *1-65530* (must be unique system wide)
5. Device Name: *xxxxxxxxxxxxxxxx* up to 15 ASCII characters)

ModBus

Select

[Meter Facilities] >>RS-485 Setup >>Protocol: *Modbus*

Under ModBus Protocol enter the following:

1. Baud Rate: *300, 1200, 2400, 4800, 9600, 38,00 (9600 is default)*
2. Parity: *None, Odd, Even* (None is default)
3. Word Format: *Normal, Reversed* (Normal is default)
4. Address: *1-254* (devices on each RS-485 network should be limited for best communication update times e.g. <10)

RS-485 Wiring

Use a recommended cable for RS-485 wiring such as Belden 9842 or Belden 3106. The two recommended BACnet routers for use with the FST020 are:

- Contemporary Controls BASRTLX-B High Performance BACnet router
- MBS GmbH UBR-01 Universal BACnet Router

Note

See manufacturer's manual for complete details on the Conversion Device wiring.

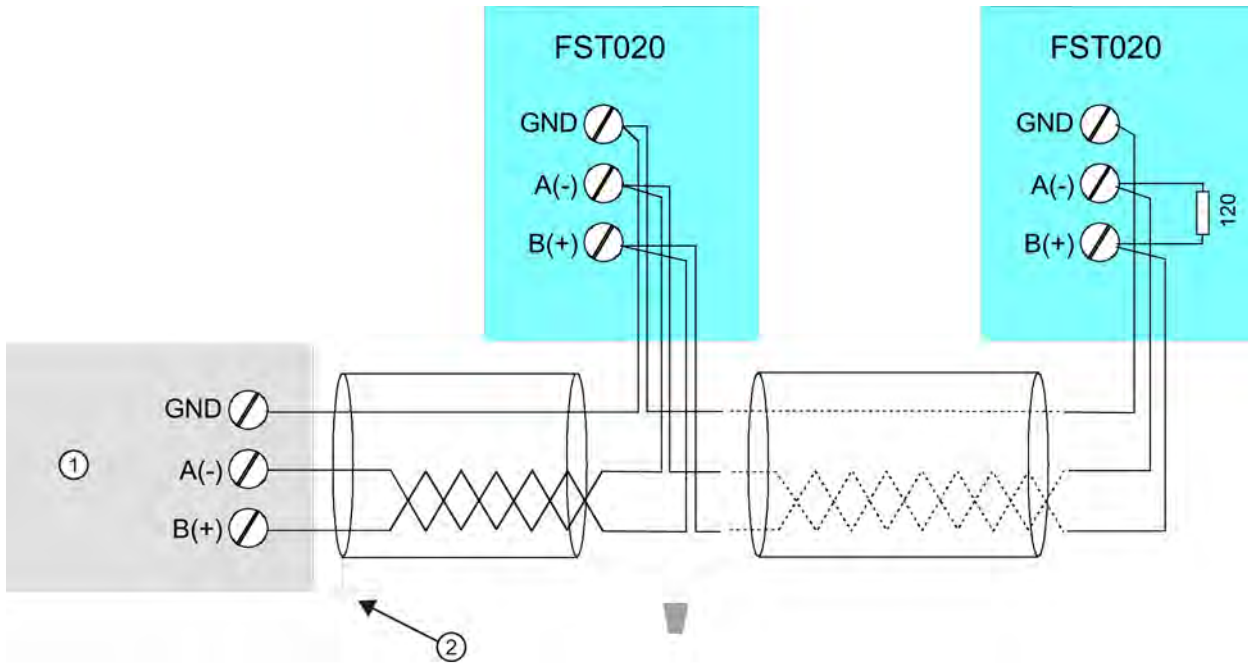

- ① Conversion Device (e.g. BACnet Router).
- ② Connect shield to chassis at one point only.

Figure 5-5 RS-485 Wiring Diagram

5.2 Navigating the Menu

Installation Menu Navigation

The Installation Menu Chart is a multi-level structure divided into three columns from left to right		
Level A - lists the major menu categories.		
Level B - list the menu cells associated with Level A. You can enter data into Level B menu cells		
Level C - lists the Level B data		
Level A	Level B	Level C
	Recall Site Setup	Pump 1 Pump 2
	Channel Enable	
	Create/name Site	
	Site Security	
	Delete Site Setup	
Save/Rename Site		

Table 5- 1 5-Key Touch Keypad and PC Keyboard Function Chart

Sensor	Description
ENTER Key	Store numeric data, select from option lists, etc.
Left / Right Keys	Menu navigation keys move cursor.
Up / Down Keys	Same as <Left> and <Right> keys. Scrolls option lists and graphic display screen.

Note

Use Left Key to return to previous menu.

Typical Installation Menu Screen Example

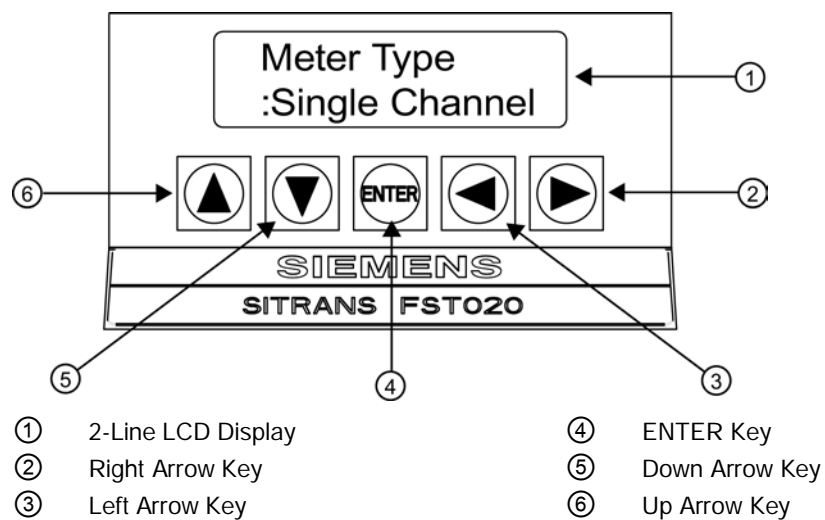

Figure 5-6 5-Key Touch Keypad

5.3 Programming the Transmitter

Note

Before creating a site select English or metric units from the Meter Facilities menu.

Select a Meter Type

1. After power-up, press <ENTER> key to access the top level of the Installation Menu.
2. [Single Channel] meter type appears.
3. Press <Right Arrow> key twice to select [Channel Setup] menu.

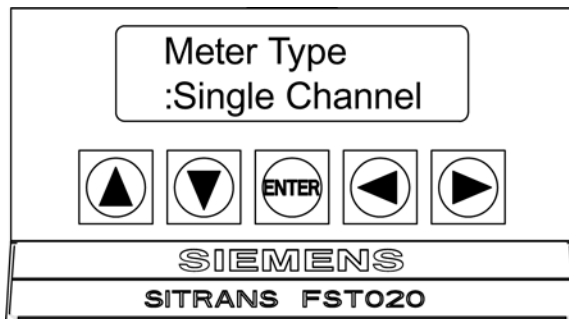

Note

IMPORTANT: Colon appears when menu item is selected for entry.

Create a Site

1. Press <Right Arrow> key and then <Up/Down Arrow> keys to select [Create/Name Site].
2. Press <Right Arrow> key to select the "?" symbol (see figure below).
3. To create site name use the <Up/Down> and <Right Arrow> keys to select a name.

4. Press <ENTER> key to save the Site name.

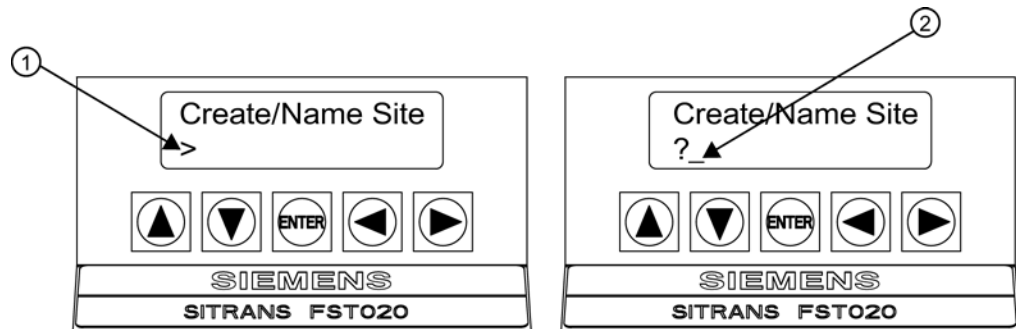

- ① Site name field is initially blank
- ② (?) Indicates cell is ready to accept data. Cursor shown in first character position.

Note

To set English or Metric units: In [Meter Type] menu, scroll to [Meter Facilities] menu. Press <Right Arrow> and select desired units. Press <ENTER> to select. Press <Left Arrow> and <Up Arrow> keys to return to [Meter Type] menu.

Note

To select alphanumeric characters: Press <Right Arrow> key to cursor and then press <Up/Down Arrow> keys to select letters and numbers.

-
5. Press <Left Arrow> key and return to [Channel Setup]. Press <Down Arrow> key to select [Pipe Data].

Note

After the site configuration procedures that follow are complete the newly created site must be saved again to retain the new site data. Refer to the Save/Rename Site procedure below.

Save/Rename Site Procedure

Whenever new site configurations are added to an existing site that site must be saved again to retain the new site changes.

1. To **save all programmed data to site**, press <Left Arrow> and then scroll up to [Channel Setup].
2. Press <Right Arrow> key and scroll to [Save/Rename Site].
3. Press <Right Arrow> key and then <ENTER> to save all programmed data to site.
4. To return to the top menu level, continue to press the <Left Arrow> key.

Select Pipe Class

1. Press <Right Arrow> key to select [Pick Pipe Class].
2. **Press <Right Arrow> key again.** Press the <Up/Down Arrow> keys to scroll to desired Pipe Class.

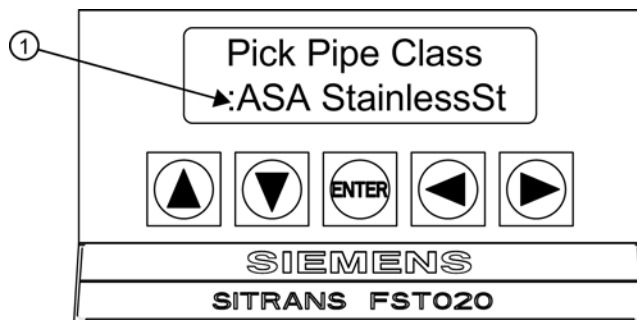

① Colon must appear first before Pipe Class can be selected.

3. Press <ENTER> key to select Pipe Class.
4. Press <Up/Down Arrow> keys to scroll down to [Select Pipe Size].
5. Press the <Right Arrow> key and then <Down Arrow> to select desired pipe size.

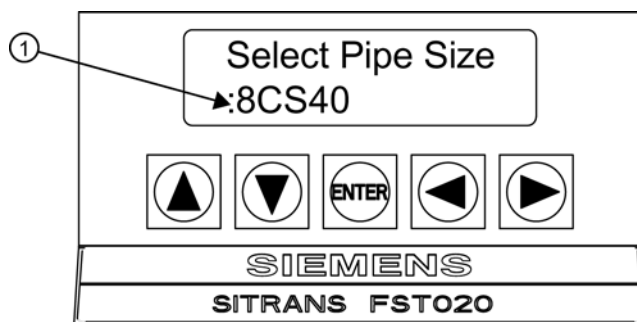

① Colon must appear first before Pipe Size can be selected.

Note

Pre-programmed Pipe Size and relevant pipe parameters will appear in menu cells. Enter dimensions manually if pre-programmed dimensions do not match application.

Note

The DN sizes listed in the [Select Pipe Size] menu option list are referenced to DIN Table 2448. After selecting pipe size, check pipe OD and wall thickness for correct dimensions.

6. Press <ENTER> key to save Pipe Size selection.

Select Liquid Class

1. Press <Left Arrow> key to select [Pipe Data] and then press <Down Arrow> key to select [Application Data].
2. Press <Right Arrow> key to select [Liquid Class].
3. Press <Right Arrow> key again to select [Select Liquid]. **Press <Right Arrow> key again.**

4. Press <Up/Down Arrow> keys to scroll to desired liquid.
5. Press <ENTER> key to save selection.

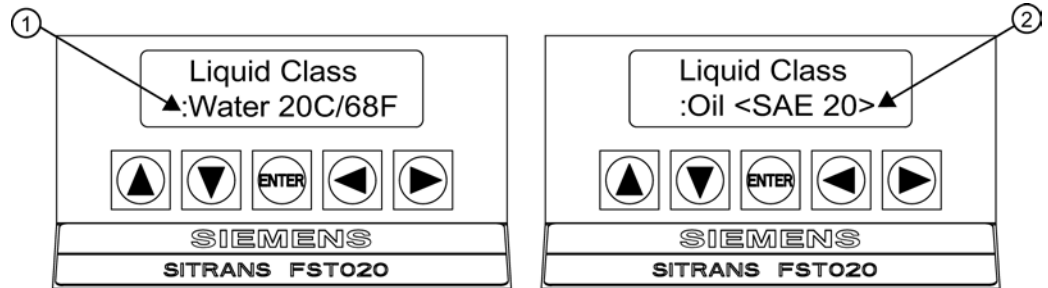

- ① Colon appears.
- ② Select new liquid from option list.

Select Pipe Configuration

1. Press <Left Arrow> key and then <Down Arrow> key to select [Pipe Config].
2. **Press <Right Arrow> key.**
3. Press <Up/Down Arrow> keys to select a configuration that approximates the conditions upstream of your sensor mounting location. (Refer to the definitions below.)
4. Press <ENTER> key to save selection. The [Anomaly Diams] menu will appear.

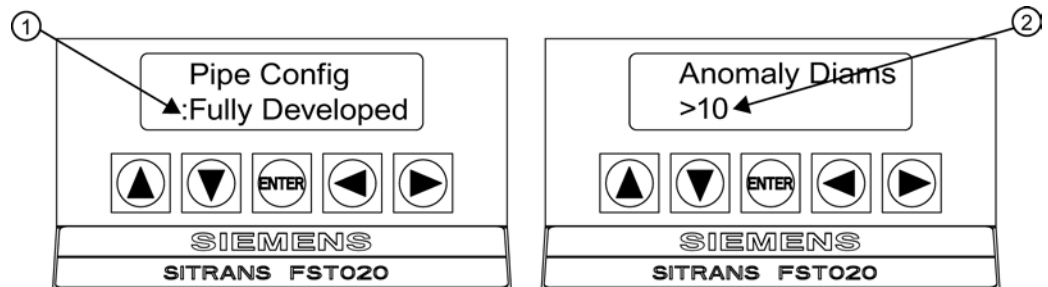

- ① Use this menu cell to select the pipe configuration that most accurately represents the upstream pipe condition.
- ② Use this menu cell to enter the number of pipe diameters between the upstream configuration and the sensor installation.

5. **Press <Right Arrow> key twice. =0 will appear.**

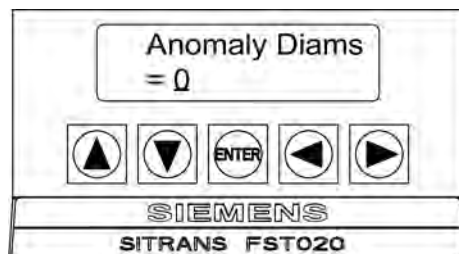

6. press <Right Arrow> and then the <Up/Down Arrow> keys to select number of pipe diameters.
7. Press <ENTER> key to save selection.

Table 5- 2 Pipe Configuration Option List Definitions

Options	Definitions
Fully Developed	Fully developed flow, as would be expected for very long straight pipe runs or installation downstream of a flow condition.
1 Elbow	Single 90 degree Elbow upstream of sensor installation.
Dble Elbow+	Double out-of-plane Elbows upstream of sensor installation.
Dble Elbow-	Double in-plane Elbows upstream of sensor installation.
Valve	Consult Factory.
Expander	Pipe expansion upstream of sensor installation.
Reducer	Pipe reduction upstream of sensor installation.
Norm Entry	Consult Factory.
Header Inlet	Header or pipe manifold upstream of sensor installation.
Intrusions	Consult Factory.

Save/Rename Site Procedure

Whenever new site configurations are added to an existing site that site must be saved again to retain the new site changes.

1. **To save all programmed data to site**, press <Left Arrow> and then scroll up to [Channel Setup].
2. Press <Right Arrow> key and scroll to [Save/Rename Site].
3. Press <Right Arrow> key and then <ENTER> to save all programmed data to site.

To return to the top menu level, continue to press the <Left Arrow> key.

Proceed to Sensor Installation (Page 37) if necessary.

Selecting a location for the sensors

1. Locate the sensors downstream from the center of the longest available straight run. A location ten pipe diameters or greater downstream from the nearest bend will provide adequate flow profile conditions.
2. Do not, if possible, install the sensors downstream from a throttling valve, a mixing tank, the discharge of a positive displacement pump or any other equipment that could possibly aerate the liquid. The best location will be as free as possible from flow disturbances, vibration, sources of heat, noise, or radiated energy.
3. Avoid mounting the sensors on a section of pipe with any external scale. Remove all scale, rust, loose paint, etc., from the location.
4. Do not mount the sensors on a surface aberration (pipe seam, etc.)
5. Do not mount sensors from different ultrasonic flowmeters on the same pipe. Also, do not run the sensor cables in common bundles with cables from other instrumentation. You can run these cables through a common conduit ONLY if they originate at the same transmitter.
6. Never mount sensors under water, unless you order submersible units and you install them in accordance with factory instructions.
7. Avoid mounting sensors on the top or bottom of a horizontal pipe. The best placement on a horizontal pipe is either the ten o'clock and two o'clock position for Reflect Mode, or one sensor at nine o'clock and one sensor at three o'clock for Direct Mode. Mounting on a vertical pipe is recommended only if flow is in the upward direction. When mounting on a vertical pipe flowing in a downward direction make sure there is sufficient back pressure in the system to maintain a full pipe.

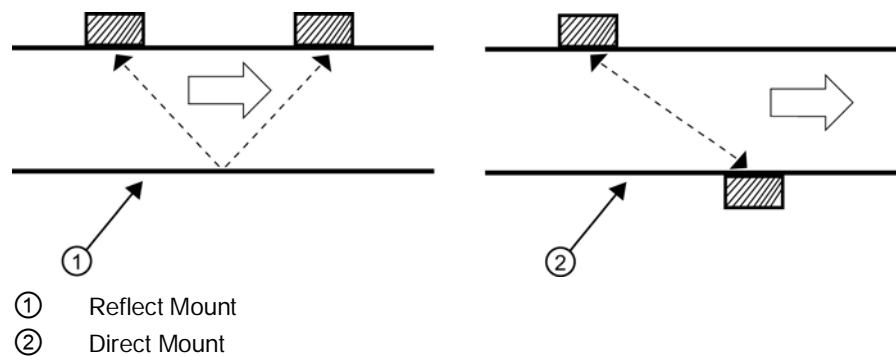
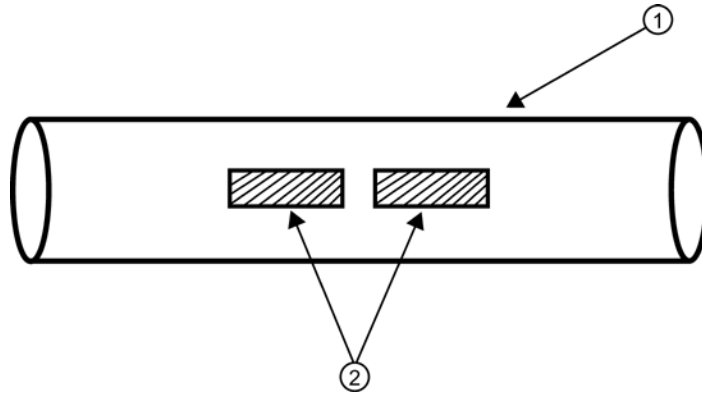

Figure 5-9 Sensor Alignment

Preparing the Pipe

1. Pick a mounting location with the longest straight run. You must have easy access to at least one side of your pipe. The pipe at the mounting location must remain full, even at zero flow.
2. Decide on your mounting mode (Direct or Reflect). Always use Reflect Mode whenever possible. You may only need to use Direct Mode if your pipe is plastic.

- After receiving the spacing dimensions from the Installation Menu, prepare the pipe surface. De-grease the surface, if necessary, and remove any grit, corrosion, rust, loose paint, etc. Use the provided abrasive materia to create a clean contact surface for the sensors.



- ① Pipe
- ② Cleaned Areas

Figure 5-10 Pipe Surface Preparation

- Clean an area 13 mm (1/2-inch) on either side of the sensors.
- Clean an additional 13 mm (1/2-inch) along the length of the sensors.

5.4.2 Sensor Identification and Selection

The sensor part number located on the front face provides a detailed identification. For example, the *Part Number: 1011HNS-D1T1-S2* means:

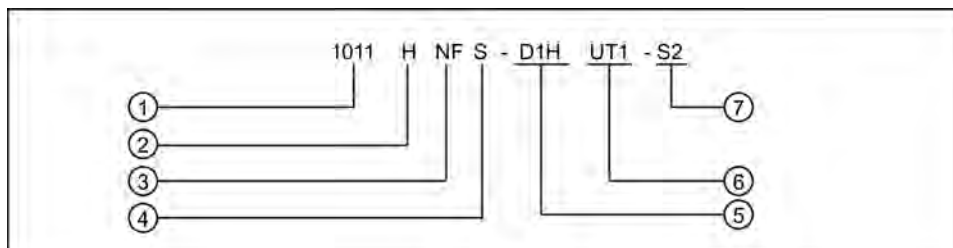

- ① Model
- ② Hi Precision
- ③ NEMA w/F-Conn
- ④ Pipe Material
- ⑤ Size
- ⑥ Temperature
- ⑦ Agency Approved

Note

Check to make sure that the sensors are a matched set with the same serial numbers and marked with an "A" and "B" (e.g., 19256A and 19256B).

Typical Sensor Labels

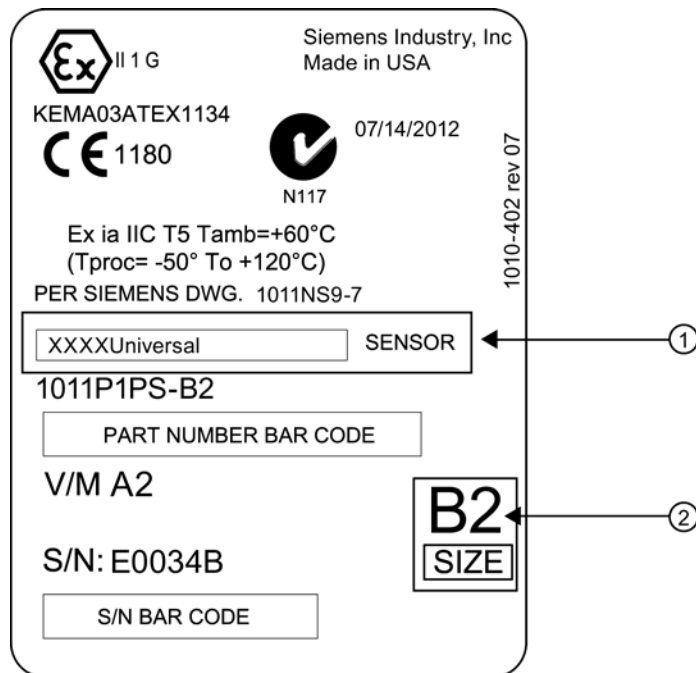

- ① Universal sensor model number
- ② Sensor size

Figure 5-11 Sample Universal Sensor Label

5.4 Installing the Sensor

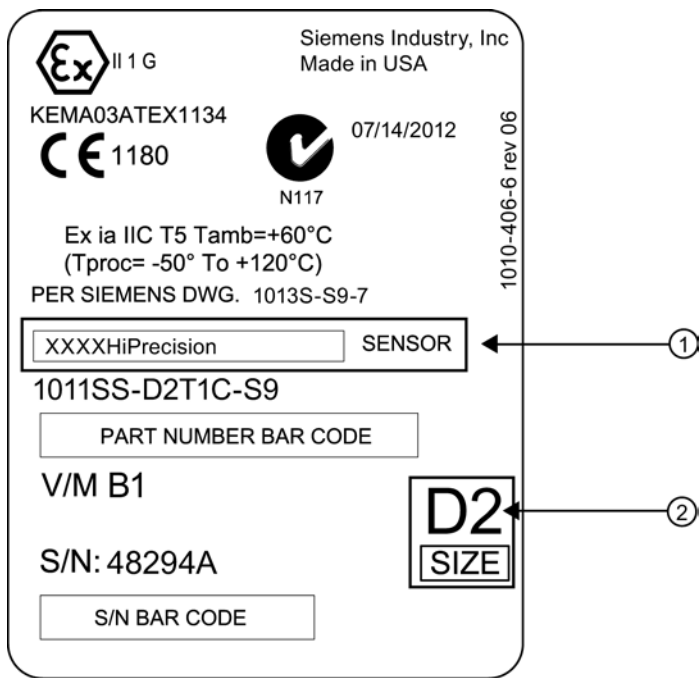

- ① Hi Precision sensor model number
- ② Sensor Size

Figure 5-12 Sample Hi Precision Sensor Label

Table 5-3 Universal Sensor Selection Chart

Sensor Size	Order Code	Outer Diameter Range (mm)		Outer Diameter Range (Inches)	
		Min.	Max.	Min.	Max.
A2	B	12,7	50,8	0.5	2
B3	C	19	127	0.75	5
C3	D	51	305	2	12
D3	E	203	610	8	24
E2	F	254	6096	10	240

Chart based on pipe size (pipes other than steel)

Table 5- 4 High Precision Sensor Selection Chart

Sensor Size	Order Code	Pipe Wall (mm)		Pipe Wall (Inches)	
		Min.	Max.	Min.	Max.
A1H	G	0,64	1,02	0.025	0.04
A2H	H	1,02	1,52	0.04	0.06
A3H	J	1,52	2,03	0.06	0.08
B1H	K	2,03	3,05	0.08	0.12
B2H	L	3,05	4,06	0.12	0.16
C1H	M	4,06	5,84	0.16	0.23
C2H	N	5,84	8,13	0.23	0.32
D1H	P	8,13	11,18	0.32	0.44
D2H	Q	11,18	15,75	0.44	0.62
D4H	R	15,75	31,75	0.62	1.25

Chart based on pipe wall thickness (steel pipes only).

Sensor Selection

The following is a typical sensor selection procedure.

Note

The transmitter must be powered up before you can select a sensor model. Refer to Transmitter Wiring (Page 21).

1. Press the <Down Arrow> key to select [Install Sensor].
2. Press the <Right Arrow> key to [Sensor Model]. Press <Right Arrow> key and scroll to select the sensor model found on the sensor label.
3. The drop down menu lists the following sensor selections:
 - 7ME39501G
 - 1011 Universal - Usable -40° to 120°C
 - 1011HP-T1 - Usable -40° to 120°C, recommended for Ø Temperature <40°C; Standard.
 - 1011HP-T2 - Usable -40° to 120°C, recommended for Ø Temperature >40°C - <80°C; Named as high temperature.
 - 1011HP-T3 - Usable -40° to 120°C, recommended for Ø Temperature >80°C <120°C; special request.
 - 1021 Sensor
 - 991 Universal

Note

The meter will automatically recommend a sensor depending on the application data that has been entered.

4. For this example, select the sensor model that appears on the sensor label and press <ENTER>. (Refer to sensor label figures above.)

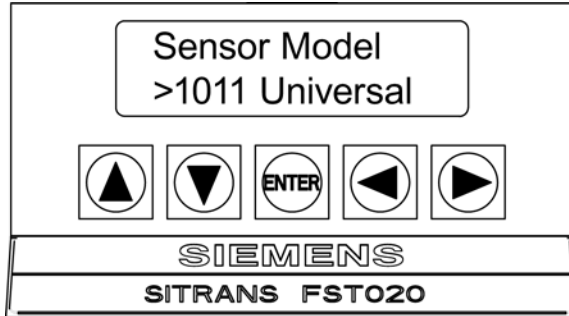

5. Press the <Down Arrow> key to [Sensor Size]. Press <Right Arrow> key and scroll to select the sensor size that matches the size indicated on sensor label then press <ENTER>.
6. At [Sensor Mount Mode] press <Right Arrow> key. Scroll to select [Reflect] or [Direct] mount then press <ENTER>.
7. **IMPORTANT:** Press the <Up/Down Arrows> keys to scroll to [Spacing Method] and [Number Index]. Record these numbers. They will be used to mount the sensors.
8. Sensors can now be mounted. Refer to the sensor mounting procedures and select the mounting mode desired.
9. Once sensor mounting is complete proceed to Commissioning (Page 65).

5.4.3 Reflect Mount using Spacer Bar

Sensor Installation using Mounting Frames and Spacer Bar

The spacer bar eliminates manual spacing measurements and provides rigidity for mounting the sensors while maintaining axial alignment. Refer to Programming the Transmitter (Page 32) before proceeding.

1. Perform all required menu steps taking note of the sensor model and size designation. The transmitter then issues the Number Index and prompts you to press <ENTER> to finish the sensor install routine. Stop at this point.

Note

Note the number index value displayed in the [Install Sensor] menu. You will use this index to properly space the sensors. Check to ensure that you have a matched set of sensors. They both should have the same S/N number but marked with either an "A" or "B" (e.g., 19256A and 19256B).

2. Prepare the pipe surface area where the sensors will be mounted. Degrease the surface and remove any grit, corrosion, rust, loose paint, etc.

Note

Before beginning refer to the Reflect Mount sensor installation diagram below.

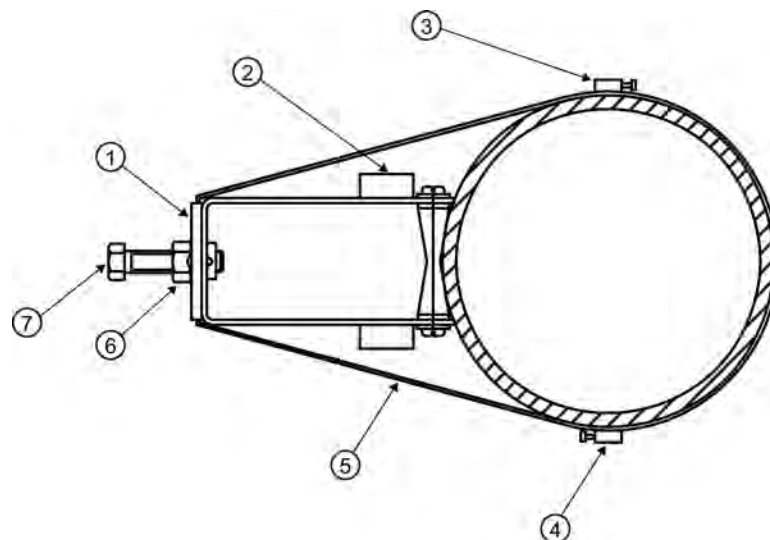

- | | |
|---|---|
| ① Mounting Frame | ⑤ Mounting Strap positioned around Mounting Frame |
| ② Spacer Bar Screw Hole | ⑥ Locking Nut |
| ③ Mounting Strap Adjusting Screw | ⑦ Sensor Clamping Screw |
| ④ Optional: On larger pipes, multiple lengths of straps can be linked together to surround pipe | |

Figure 5-13 Reflect Mount with Mounting Frames and Spacer Bar

Ltn Menu Cell

This view only menu cell shows the distance in inches or millimeters between the front faces of the sensors along the axis of the pipe. If you are mounting the sensors without a track or spacer bar, you have to space them according to this value. Note that Ltn may be a negative number for direct mount on very small pipes where the sensor spacing overlaps.

Preparing the Pipe

1. Assemble the mounting frames and sensors, with the cable connectors facing away from each other as shown below. The spacer bar is attached to each sensor using a sensor Reference Index screw. One sensor is attached using the "REF" hole on the spacer bar. The second sensor is attached to the spacer at the Number Index hole.

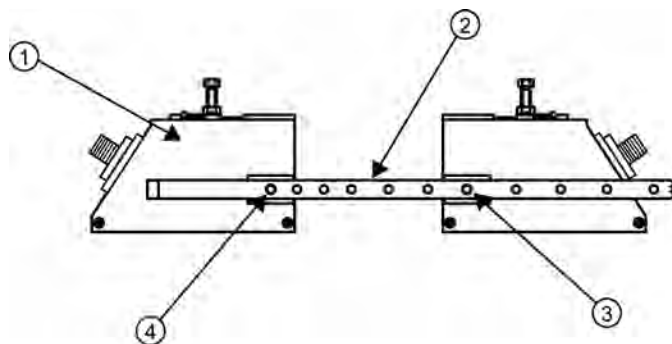

- ① 1012FNFS Mounting Frame & Sensor
- ② 1012BN Spacer Bar
- ③ Number Index Hole
- ④ REF hole

Figure 5-14 Reflect Mount, Spacer Bar-Side View

2. Temporarily position the assembly at the location where you have determined it would be mounted. Ensure that it is a smooth area without any raised spots or seams.
3. Mark a generous area around the sensors (13mm / 1/2" on either side) with a pencil or chalk. Remove the assembly.

4. Prepare the two areas you marked by degreasing the surface, if needed, and removing any grit, corrosion, rust, loose paint or surface irregularities with the abrasive pipe conditioning material provided. Clean the pipe of all debris and abrasive particles.

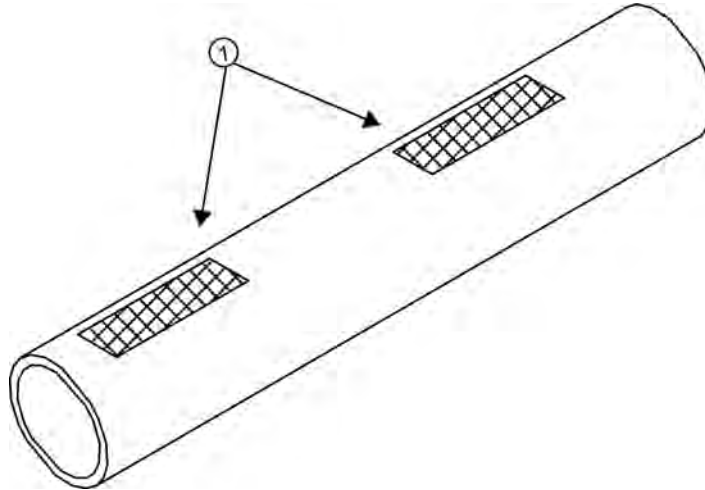

① Clean areas

Figure 5-15 Preparing the Pipe

5. Wrap a Mounting Strap around the pipe. Make sure to position strap so there is easy access to the Mounting Strap Adjusting Screw.
6. Place the assembled Mounting Frame so that it rests on the top of the pipe.
7. Engage the end of the Mounting Strap with the Mounting Strap Adjusting Screw.
8. Slide Mounting Strap under the spring clip of one of the Mounting Frames.
9. Tighten the Mounting Strap Screw enough to take up all the slack, but not enough to prevent rotation of the Frame Assembly. Repeat Mounting Strap procedure for the other Mounting Frame.
10. Rotate and align the Mounting Frame assembly to the final conditioned pipe surface location, ensuring that the assembly is straight along the pipe axis. (Refer to the sensor orientation in the Sensor Installation figure below.)
11. Tighten the Mounting Straps to seat the assembly firmly on the pipe. Do not over tighten.

Installing the Sensor

1. Take either sensor and apply a continuous lengthwise 3mm (1/8-inch) bead of coupling compound across the center of the sensor emitting surface.

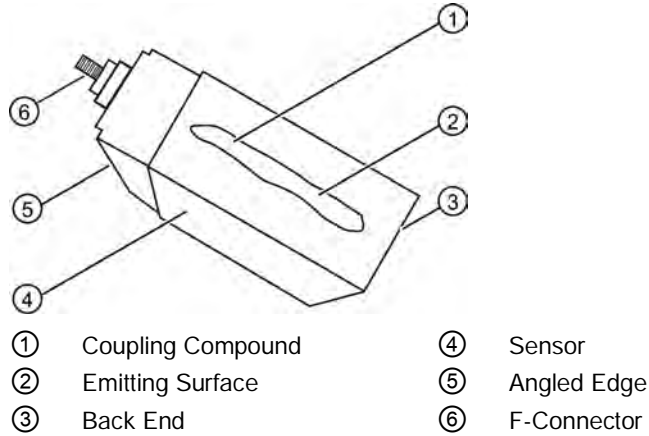
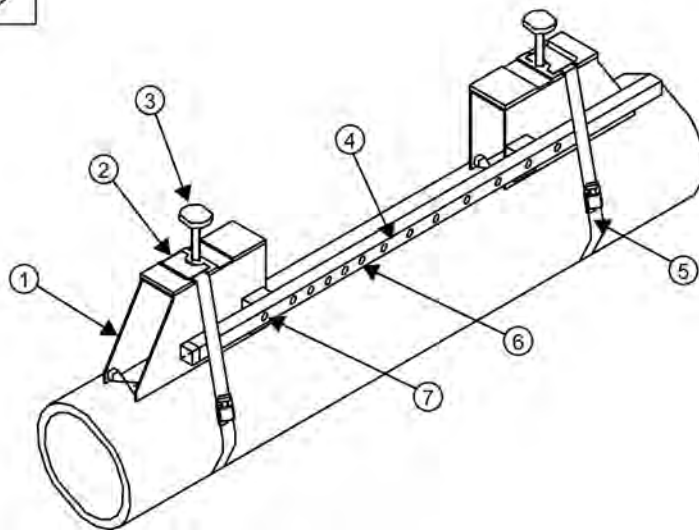
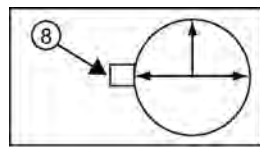

Figure 5-16 Sensor



- | | | | |
|---|---|---|--|
| ① | 7ME39600M Mounting Frame | ⑤ | Mounting Strap. Note: Optional 2nd Mounting Strap may be needed for additional support on larger pipes, over 76cm (30 inches). |
| ② | Spring Clip (not present on all models) | ⑥ | Index holes |
| ③ | Sensor Clamping Screw | ⑦ | Spacer Bar REF hole |
| ④ | 1012BN Spacer Bar | ⑧ | Orientation of sensor at 9 o'clock position |

Figure 5-17 Sensor Installation

2. Slide sensor into a Mounting Frame back end first aligning the angled edge of the sensor with the angled edge of the Mounting Frame. Keep sensor from making contact with the pipe until it butts up against the Mounting Frame stop. Push sensor down to mate with pipe.
3. Tighten the sensor clamping screws to hold the sensor firmly in place. Repeat procedure for the other sensor.
4. Proceed to Sensor Wiring (Page 63).

See also

Commissioning (Page 65)

5.4.4 Direct Mount

Sensor Installation using Mounting Frames, Spacer Bar and Spacing Guides

The combination of mounting frames, spacer bar and spacing guides is the recommended way to mount Direct Mode sensors. The mounting frame establishes the axial alignment of the sensors and allows you to remove and replace either sensor while preserving their exact mounting location.

For Direct Mode mounting, a spacer bar is used to establish the distance between sensors and a spacing guide to locate the sensors at the nine o'clock and three o'clock positions. Should the distance between sensors be beyond the span of a spacer bar, a measuring tape can be used. The Mylar spacing guide comes in various lengths and widths to accommodate most pipe sizes.

Spacing Guide Sizes	
Metric	English
5.08cm x 66.04cm	2" x 26"
5.08cm x 114.3cm	2" x 45"
10.16 cm x 205.7cm	4" x 81"
10.16cm x 393.7cm	4" x 155"
15.2cm x 497.8cm	6" x 196"

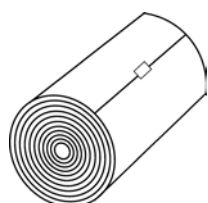
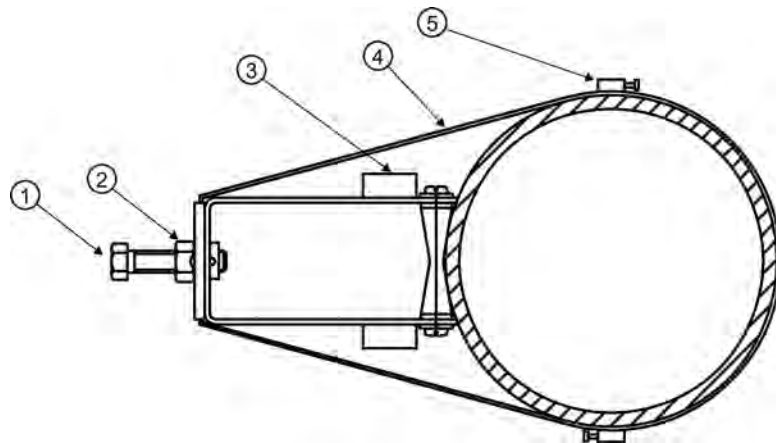

Figure 5-18 Mylar Spacing Guide

1. After receiving the spacing index from the Installation Menu, prepare the pipe surface area where the sensors will be mounted.
2. Degrease the surface and remove any grit, corrosion, rust, loose paint, etc.
3. Make a note of the Number Index displayed in the Install Sensor menu. Check to ensure that you have a matched set of sensors. They both should have the same S/N number but marked with either an "A" or "B" (e.g., 100A and 100B).
4. Temporarily position one of the frames on the pipe where you will be mounting it. Ensure that this is a smooth area without any raised areas (seams, etc.) With a pencil or chalk, mark a generous area around the frame 13 mm (1/2") on either side. Remove the assembly.
5. Prepare the area you marked by de-greasing surface, if needed, and removing any grit, corrosion, rust, loose paint or surface irregularities with the abrasive material provided.
6. Put a mounting strap around the pipe and engage an end into adjusting screw (screw should be pointing up). Position frame in the middle of area you have cleaned and centered on the pipe with its angled end facing away from where the other frame will sit.



- | | |
|-------------------------|----------------------------------|
| ① Sensor Clamping Screw | ④ Mounting Strap |
| ② Locking Nut | ⑤ Mounting Strap Adjusting Screw |
| ③ Spacer Bar Screw Hole | |

Figure 5-19 Wrap Strap Under Pipe and Attach to Adjusting Screw

7. Slide the mounting strap over it (and under the clip if there is one) and tighten with a screwdriver. While tightening, check to ensure that the center of the tapered roller is centered on the pipe.
8. Attach the second frame to the spacer bar with an index spacer screw into the Index hole specified in Step 1. The angle on the frame should be facing away from the direction that the length of the bar is going.

9. Now attach the free end of the spacer bar by inserting an index spacer screw through the REF hole on the spacer bar and then into the hole on the mounted frame. Tighten. Sight to ensure that this frame is lined up in the center of the pipe and, while holding this alignment, place a dot (with pencil or chalk) in the center of the tapered roller at the bottom of the frame (see A below). While holding alignment, also mark along the front edge of the frame with pencil or fine chalk line (see B below).

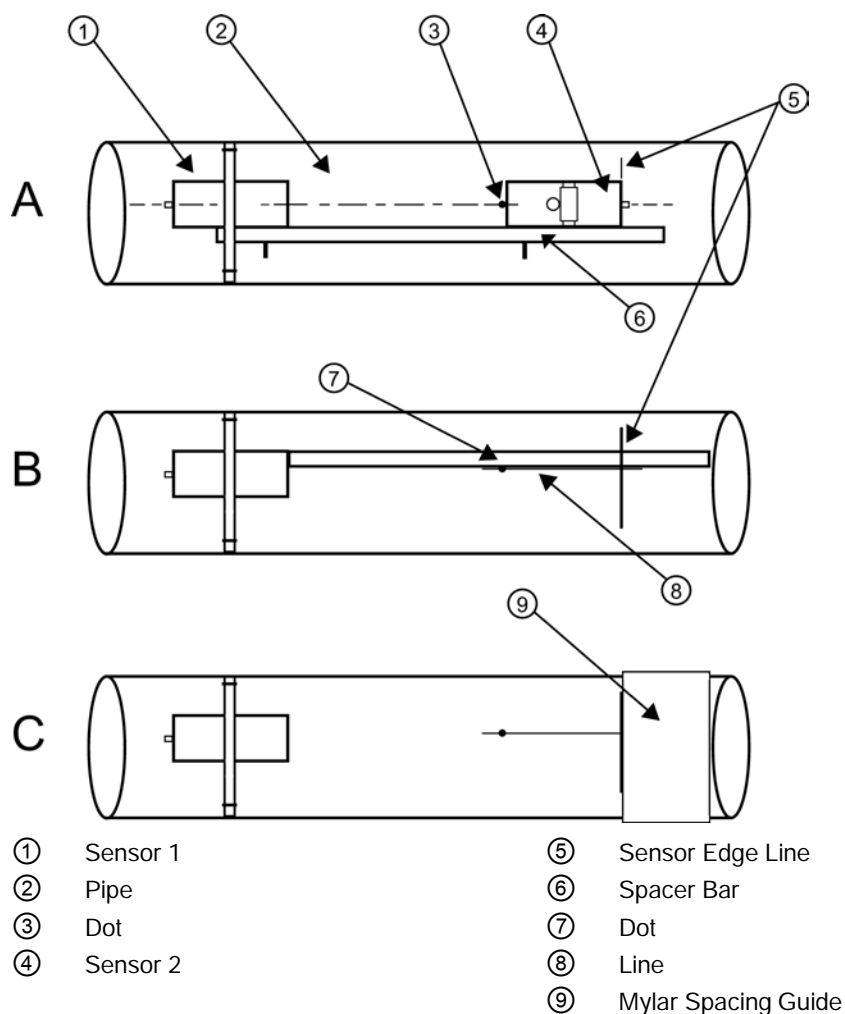
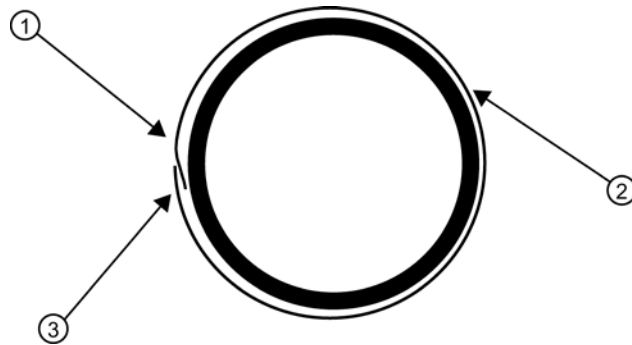

Figure 5-20 Aligning the Sensor to the Pipe

- Disassemble the spacer bar and the unmounted frame. Use the bar as a straight edge and, with one edge against the mounted frames tapered roller center and the other crossing the dot you drew, draw a line crossing the dot (see "B" above). Set the bar aside.



- ① Trim material from inner edge if necessary
- ② Mylar Spacing Guide
- ③ 8cm (3-inch) Overlapping Edge

Figure 5-21 Wrapping the Mylar Spacing Guide around the pipe (End View)

- Wrap the Mylar spacing guide around the pipe so that the left edge is against the sensor edge mark (see "C" above). Arrange so that one end overlaps the other by at least three inches. Trim to fit if necessary, but be sure not to trim at the overlapping end in order to keep it square.
- Realign left edge of the guide with the sensor edge mark. Line up both vertical edges of the guide and ensuring that it is snug around the pipe, mark along the overlapping edge.
- Remove Mylar spacing guide and lay it out on a flat surface. Either measure the exact distance half-way between the overlap edge and the mark at the overlap, or fold the guide from the overlap edge to overlap mark and draw a line at the fold or halfway point.

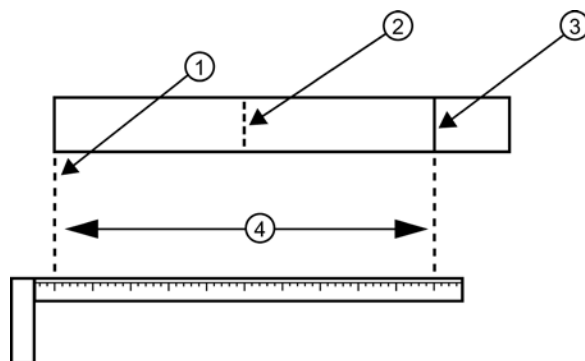

- ① Overlap Edge
- ② Mark (or fold) exactly at half-way point
- ③ Spacing Guide
- ④ Circumference

Figure 5-22 Finding the Halfway Distance

- Reinstall the spacing guide; its left edge abutting the sensors edge mark on the pipe and the overlapping edge in line with the dot (now a line) on the pipe (see "C"). Tape it in this position on the pipe. Take the second frame and place it against the edge of the guide with its tapered roller centered on the center mark on the guide.

15. Temporarily position the frame (in the 3 o'clock position opposite the mounted frame - see below) where it will be mounted. Ensure that this is a smooth area without any raised spots (seams, etc.). Mark a generous area of 13mm (1/2-inch) around the mounting frames on either side with a pencil or chalk. Remove the frame and the Mylar guide.

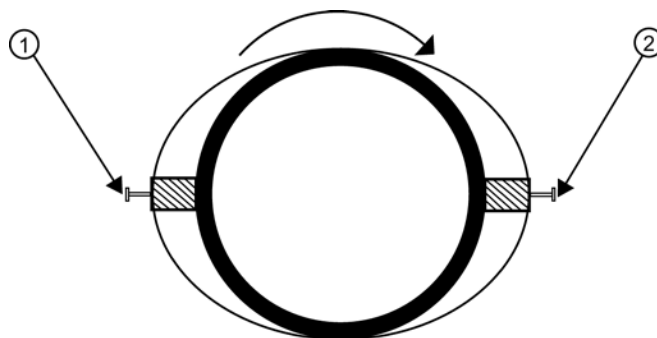

- ① 9 o'clock Sensor
 ② 3 o'clock Sensor

Figure 5-23 Aligning the Sensors for Direct Mode operation (End View)

16. Prepare the area you marked by de-greasing the surface, if needed, and removing any grit, corrosion, rust, loose paint or surface irregularities with the abrasive pipe conditioning material provided. Clean the pipe of any debris and abrasive particles.
17. Replace the Mylar guide back in the same position it was in and retape it to the pipe.
18. Put a mounting strap around the pipe and engage an end into adjusting screw (screw should be pointing up).
19. Position frame in the middle of area you have cleaned and centered on the pipe with its angled end facing away from where the other frame will sit and aligned with the edge and center marks on the guide. Slide the mounting strap over it (and under the clip if there is one) and tighten with a screwdriver. While tightening, check to ensure that the center of the tapered roller is centered on the pipe.
20. Take either sensor and apply a continuous lengthwise 3mm (1/8-inch) bead of coupling compound across the center of the sensor emitting surface.
21. Tighten the sensor clamping screws to hold the sensor firmly in place. *Repeat procedure for the other sensor.*
22. Slide sensor into a mounting frame back end first aligning the angled edge of the sensor with the angled edge of the mounting frame. Keep sensor from making contact with the pipe until it butts up against the mounting frame stop. Push sensor down to mate with pipe.
23. Open the transmitter top cover. Using a flat blade screwdriver, remove the Cable Strain Relief bracket.
24. Observing the upstream and downstream orientation, attach the UP (upstream) and DN (downstream) cables to the sensors and make snug. Attach the other ends to the UP and DN terminals of the transmitter.
25. Replace the Cable Strain Relief bracket. Close top cover.
26. Proceed to Sensor Wiring (Page 63) and then Commissioning (Page 65).

5.4.5 1012T Mounting Tracks

Using 1012T Sensor Mounting Tracks

The 1012TN and 1012TNH Mounting Tracks provide a rigid mounting platform for Series 1011 Universal or high precision size A or B sensors. The mounting tracks service pipe sizes up to a maximum of 5.00" (140 mm) outer diameter. Operating temperatures are supported up to 121°C (250°F). The assembly consists of lightweight aluminum track rails with integral sensor clamping screws. Attached index pins enable positive locating of the sensors at fixed spacing locations. Roller-chains and tension screws secure the assembly to the pipe.

The 1012T mounting tracks support both Direct and Reflect mounting modes. The transmitter recommends the appropriate sensors, mounting track and mounting mode, based on the pipe data entries. Refer to the sensor installation procedures, and if necessary, review how to select and prepare a pipe mounting location.

Installing a 1012T Mounting Track in Reflect Mode

The Sensor Installation procedures show how the automatic selection of sensors, mounting mode and spacing method are established. Examine the figure below, which illustrates a typical [Install Sensor] menu screen. The assignment of the mounting track part number and the designation of the number index are automatic. To view this data, at the [Install Sensor] menu, press the <Right Arrow> and scroll down to the appropriate menu cell.

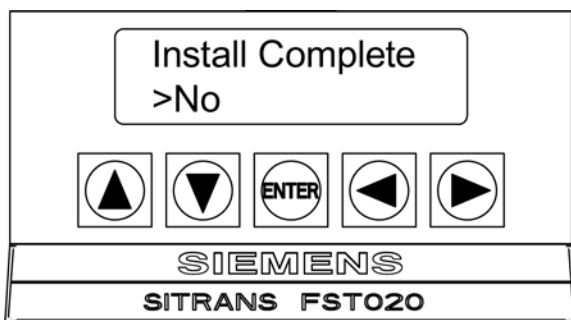

1. Perform all required menu steps up until the point where you respond to the [Install Complete] prompt.
2. Make note of the Number Index. Check to ensure that you have a matched set of sensors. They both should have the same serial number but marked with either an "A" or "B" (e.g. 100A and 100B).

Note

An index pin will be inserted into the track rail hole designated by the Number Index to position one of the sensors (see ⑪ in figure below).

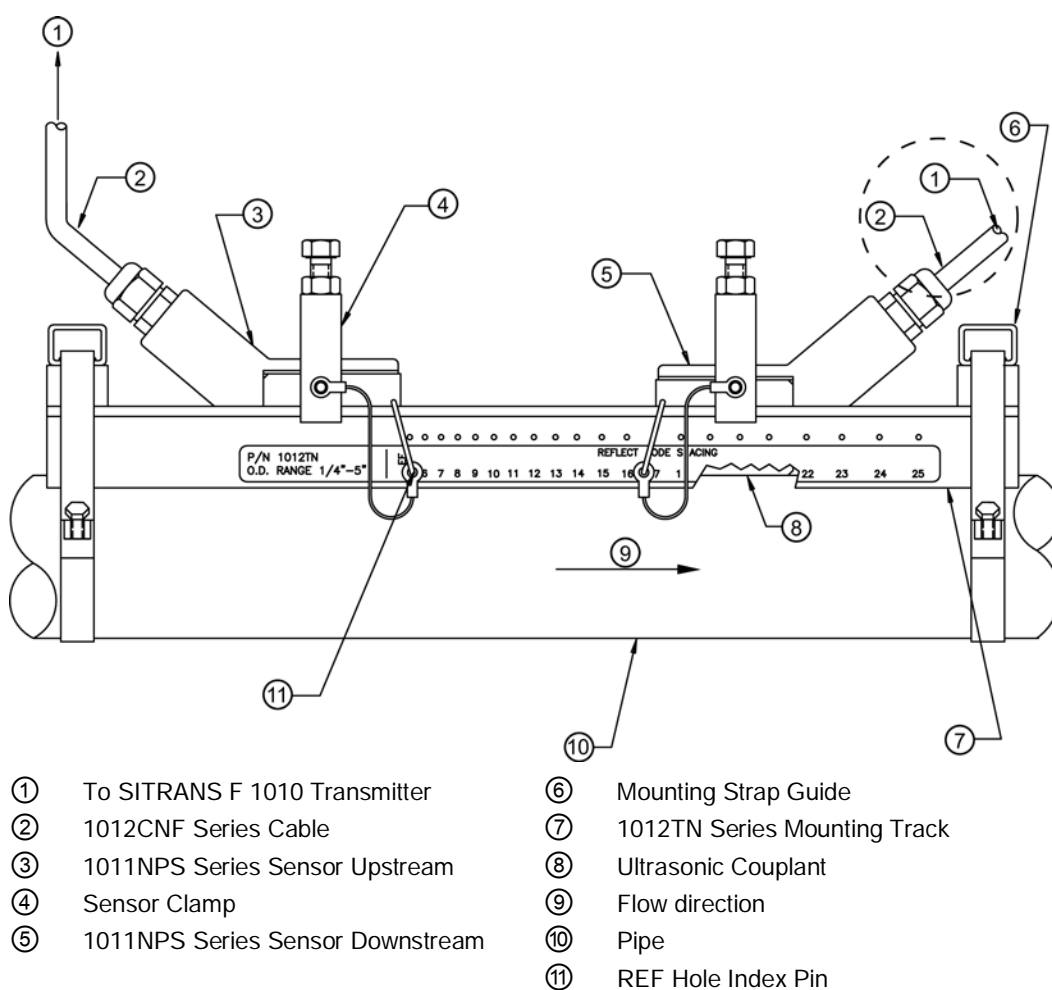

Figure 5-24 Reflect Mount with Model 1012TN Mounting Track (Side View)

3. Place the track rail assembly on the top surface of the pipe at the location where you have determined it would be mounted. Ensure that it is a smooth area without any raised spots or seams.
4. Holding the mounting track assembly in place, loop one of the strap clamps under the pipe, pull it around and maintain tension while slipping a link over the tension screw hook. Tighten the tension screw enough to hold the assembly on the pipe, but still allow rotation. Repeat for the other mounting strap.

5. Rotate the track rail assembly to the intended mounting position on the pipe, then tighten both tension screws just enough to prevent rotation. Do not over tighten.
6. With a pencil or chalk mark a generous area around the perimeter of the track assembly. Loosen and move the assembly away from marked area.
7. Prepare the area you marked by degreasing the surface, if needed, and removing any grit, corrosion, rust, loose paint or surface irregularities with the abrasive pipe conditioning material provided. Clean the pipe of all debris and abrasive particles.
8. Rotate the track into the position that was just cleaned. Insert the index pin into the REF hole.
9. Insert the index pin into the reference hole.
10. Select a sensor and apply a thin band of couplant compound to the sensor's emitting surface.
11. Place the sensor between the track rails, slightly behind the pin and under the clamping screw assembly. Slide it forward until it butts up firmly against the reference pin.
12. Once the sensor is in place secure it with the sensor clamping screw. Do not over tighten.
13. Repeat the procedure for the Number Index sensor making sure to insert an index pin into the correct Number Index hole. Refer to the Model 1012TN Mounting Track (side view) figure above.
14. Observing the upstream and downstream orientation, attach the UP (upstream) and DN (downstream) cables to the sensors and make snug. Attach the other ends to the UP and DN terminals of the transmitter.

Installing a 1012T Mounting Track in Direct Mode

The Sensor Installation procedures show how the automatic selection of sensors, mounting mode and spacing method are established. Examine the figure below, which illustrates a typical [Install Sensor] menu screen. The assignment of the mounting track part number and the designation of the number index are automatic. To view this data, at the [Install Sensor] menu, press the <Right Arrow> and scroll down to the appropriate menu cell.

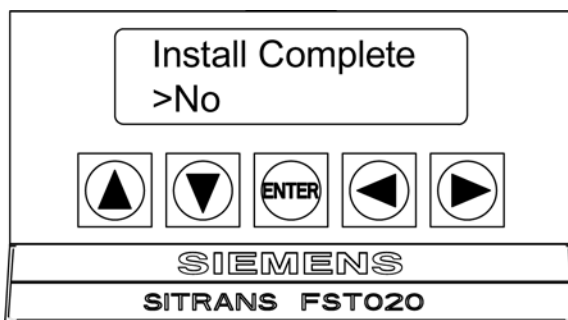

The combination of two Model 1012TN Mounting Tracks and a spacer guide is the recommended way to mount sensors in the Direct Mode. This method ensures that sensors will align exactly 180° from each other and remain spaced the proper distance apart.

The Direct Mount configuration uses a set of two track rail assemblies; one for each sensor, installed 180° apart on the pipe. The set includes:

- Reflect Mode Track Assembly - This track rail includes the Tension Screw and REF hole to position one sensor.
- Direct Mode Track Assembly - This track rail has number index holes for inserting an index pin to position the other sensor.

Note

A pin will be inserted into the hole designated by the Number Index on the Direct Mode track rail to position one of the sensors (see ⑩ in figure below).

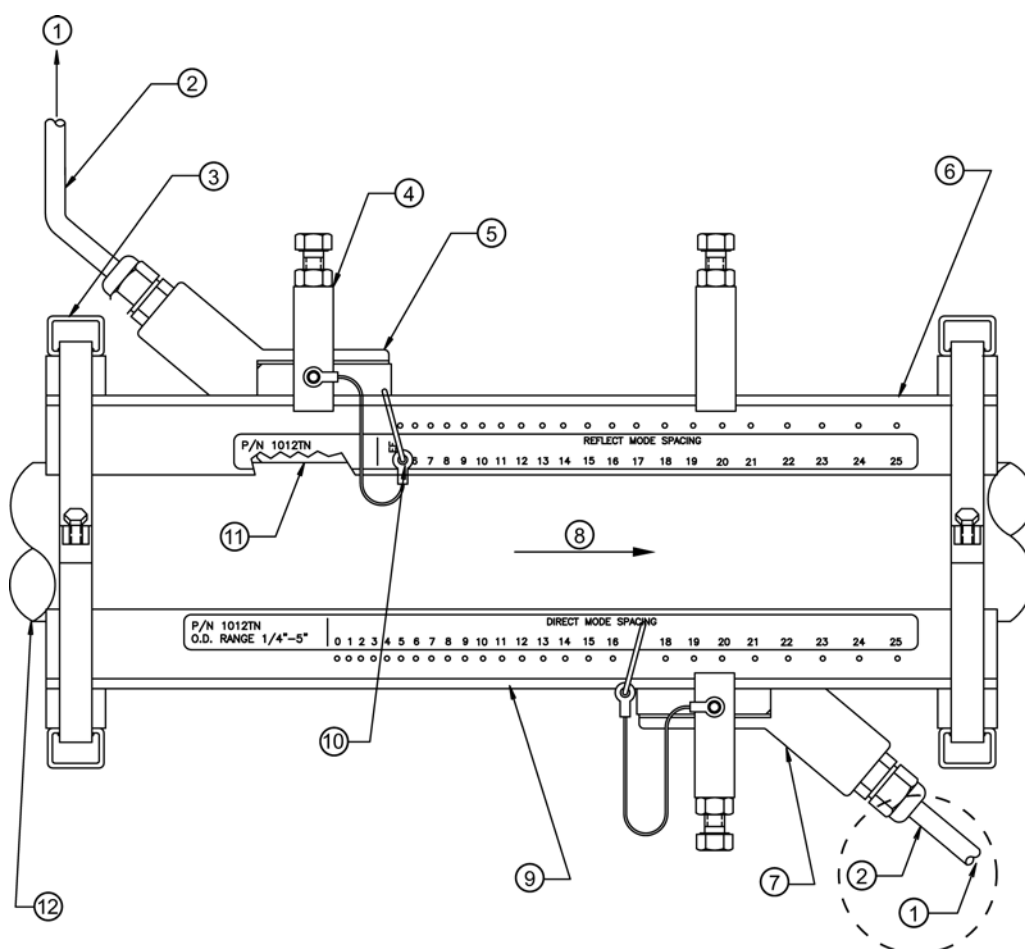

- | | |
|----------------------------------|------------------------------------|
| ① To SITRANS F Transmitter | ⑦ 1011NPS Series Sensor Downstream |
| ② 1012CNF Series Cable | ⑧ Flow direction |
| ③ Mounting Strap Guide | ⑨ 1012TN Series Mounting Track |
| ④ Sensor Clamp | ⑩ REF Hole Index Pin |
| ⑤ 1011NPS Series Sensor Upstream | ⑪ Ultrasonic Couplant |
| ⑥ 1012TN Series Mounting Track | ⑫ Pipe |

Figure 5-25 Direct Mount 180° opposed with Mounting Tracks

1. Perform all required menu programming steps up until the point where you respond to the [Install Complete?] prompt.
2. Make a note of the reported Number Index displayed in the [Install Sensor] menu. Check to ensure that you have a matched set of sensors. They both should have the same serial number but marked with either an "A" or "B" (e.g. 100A and 100B).

Note

Some sensors require a right-angle adapter. This adapter should be installed before placing the sensors in the tracks.

3. Prepare pipe for the track mounts by degreasing the surface, if needed, and removing any grit, corrosion, rust, loose paint or surface irregularities with the abrasive pipe conditioning material provided.
4. If this is a horizontal pipe, place the track rail assembly against the pipe. While holding track, place second track on pipe directly underneath (180°) and hold together in place.
5. Wrap the mounting strap around the pipe and through the strap guide.

Note

For a vertical pipe installation, use a tie, tape or bungee cord to hold the two tracks in place while mounting.

6. Finger-tighten the chain Tension Screw to secure the strap and tracks to the pipe.

Positioning Track Assemblies

1. Wrap a length of the Mylar spacing guide around the pipe and against the end of the track assemblies. Ensure that the spacer guide edges on both sides align. Arrange so that one end overlaps the other by at least 8 cm (3 inches). Trim to fit if necessary, but in order to keep the end square, be sure not to trim at the overlapping end.

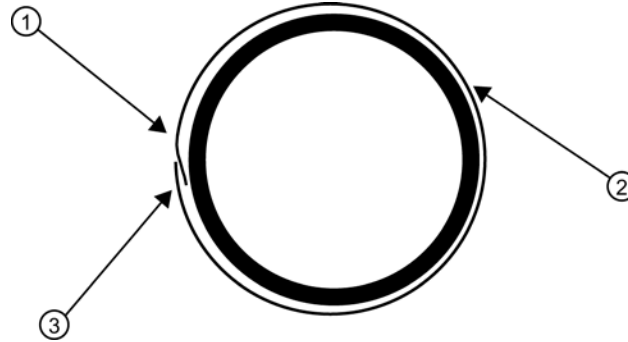

- ① Trim material from inner edge if necessary
- ② Mylar Spacing Guide
- ③ 8 cm (3-inches) Overlapping Edge

Figure 5-26 Wrapping the Mylar Spacing Guide around the pipe (End View)

2. Remove the spacer guide. Measure or fold spacer guide to find its halfway distance. Mark a center line and then tape spacer guide to pipe.

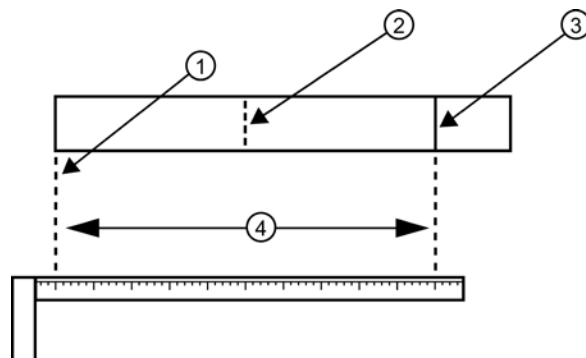

- ① Overlap Edge
- ② Mark (or fold) exactly at half-way point
- ③ Mark on Spacing Guide
- ④ Circumference

Figure 5-27 Finding the Halfway Distance

3. Use the edge of the Spacer Guide as a stop for both tracks to keep them parallel. Adjust tracks as necessary.

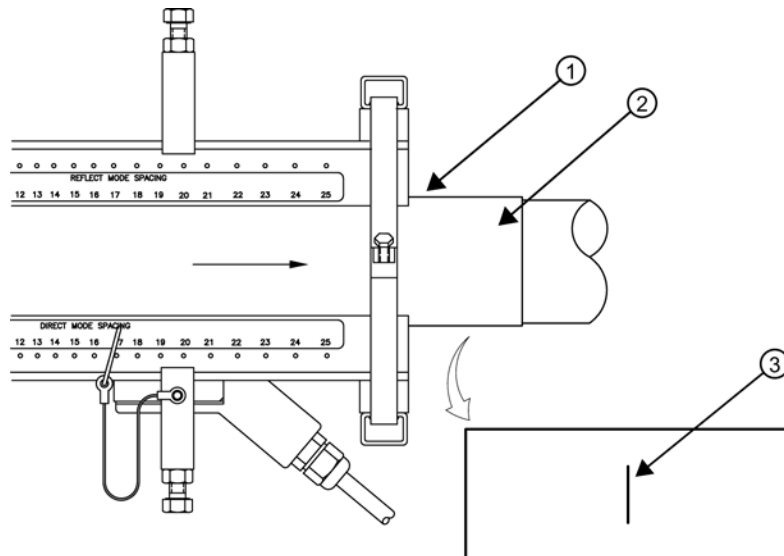

- ① Align tracks with Spacer Guide edge
- ② Mylar Spacer Guide
- ③ Halfway distance of Spacer Guide

Figure 5-28 Track Rail Alignment

4. Loosen the mounting straps enough to allow you to rotate the track assembly until the center of one track aligns with the center line on the Spacer Guide and the center of the other track aligns at the point where the Spacer Guide ends meet. The tracks should now be 180° apart. Tighten both chains but not too tight.

Sensor Installation

1. Insert an index pin into the REF hole of the track marked "Reflect Mode Spacing."
2. Take one of the sensors and insert it between the track rails and to the left of the index pin with the cable connector pointing away from the pin. Move the sensor until the pin stops it. Hold sensor in place. Move sensor clamping screw over the sensor and tighten.

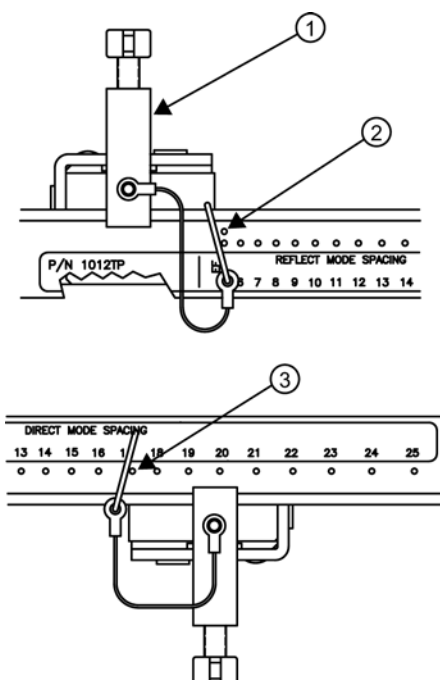

- ① Sensor Clamping Screw
- ② REF hole
- ③ Number Index hole

Figure 5-29 REF and Number Index Pin Locations

3. Insert the other index pin into the correct Number Index hole on the other track marked "Direct Mode Spacing."
4. Insert the second sensor into the track rail with its cable connector pointing away from the pin. Move the sensor until it's stopped by the pin. Move sensor clamping screw over the sensor and tighten.
5. Using a pencil or chalk, mark a generous area around where the sensors contact the pipe.
6. Release the tension on the sensors and remove them.
7. Loosen the mounting straps and rotate the track assembly on the pipe so you can gain access to the areas marked.
8. Prepare the areas you marked by degreasing the surface, if needed, and removing any grit, corrosion, rust, loose paint or surface irregularities with the abrasive pipe conditioning material provided.
9. Rotate the track assemblies into their original position on the pipe. Use the edge of the Mylar guide as a stop for both tracks and keep them parallel. Align each track with the "center line" you previously marked on the Spacing Guide. Tighten tracks securely.

10. This time, before installing each sensor, apply a 3mm (1/8-inch) continuous bead of couplant compound along the center (the long way) of the contact surface of the sensor. Also, keep the sensors lifted slightly from the pipe when installing until the sensor is against the pin; then push down against the pipe.

Note

Remember to install the sensors with the cable connectors facing away from each other.

11. Once the sensors are in place, secure with its clamping screws. Do not over tighten.
12. Observing the upstream and downstream orientation, attach the UP (upstream) and DN (downstream) cables to the sensors and make snug. Attach the other ends to the UP and DN terminals of the transmitter.
13. Proceed to Sensor Wiring (Page 63) and then Commissioning (Page 65).

5.5 Sensor Wiring

5.5.1 Wiring the Sensors

1. Using a flat blade screwdriver loosen the six securing screws and open the transmitter top cover.
2. Observing the upstream and downstream orientation, attach the UP (upstream) and DN (downstream) cables to the sensors and make snug. Thread cables through case gland and attach the other ends to the UP and DN terminals of the transmitter (see figure below).
3. Close top cover and tighten securing screws.

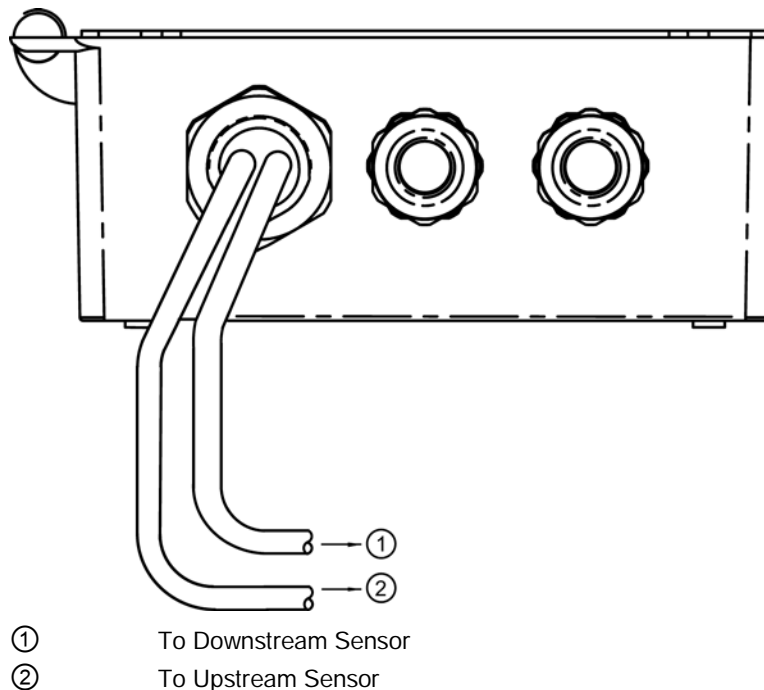

Figure 5-30 Connecting Sensor Cables to Transmitter

Commissioning

Before commissioning, it must be checked that the device has been installed and connected in accordance with the guidelines provided in chapter 4 "Installing/mounting (Page 15)" and 5 "Connecting (Page 21)".

6.1 Commissioning

1. Scroll down to [Install Complete]. Press the <Right Arrow> key.
2. Press the <Down Arrow> key and select [Install].
3. Press <ENTER> key. The flow meter will go through drives.
4. Observe the Measured Vs window and verify a correct sound velocity measurement (if known).
5. Press the <Down Arrow> key to accept sound velocity value. Auto Zero will follow.

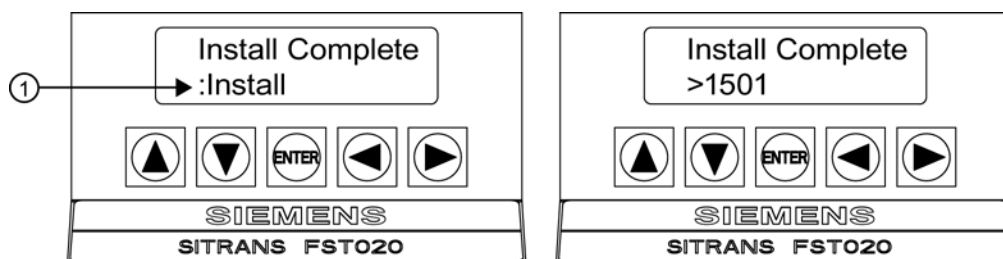

- ① Select [Install].

Note

Save and Rename Procedure

Whenever new site configurations are added to an existing site that site must be saved again to retain the new site changes.

1. **To save all programmed data to site**, press <Left Arrow> key and then scroll up to [Channel Setup].
 2. Press <Right Arrow> key and scroll to [Save/Rename Site].
 3. Press <Right Arrow> key and then <ENTER> to save all programmed data to site.
 4. To return to the top menu level, continue to press the <Left Arrow> key
-

6. **The flow meter is now ready to report flow.**

7. Press the <Left Arrow> key until the screen displays flow data or press <ENTER>.

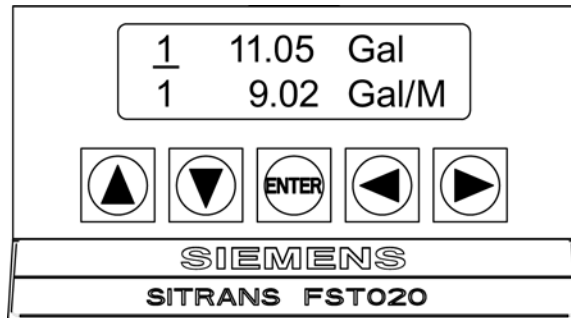

Figure 6-1 Measuring Flow

8. Use the <Right Arrow> and <Up/Down Arrow> keys to switch between display lines and to select flow data items.

See also

Refer to I/O Connection and Wiring (Page 127) for input/output wiring and data spanning procedures.

6.2 Empty Pipe Set

The flow meter performs the MTYmatic routine automatically during its Initial Make-up to establish a standard setting for the Empty Pipe alarm. This process is normally sufficient for setting this parameter. The [Empty Pipe Set] option list allows you to re-invoke MTYmatic, use an Actual MTY routine (if application conditions allow you to empty and refill the pipe) or use the Set Empty routine to set the empty pipe threshold by direct numeric entry.

Actual MTY Command

If application conditions allow you to empty and refill the pipe, then you may choose to perform the Actual Empty procedure; however, it is not required to do so.

Note

IMPORTANT

NEVER perform the Actual MTY procedure if the pipe can not be emptied.

To use the Actual MTY command:

1. From [Channel Setup] scroll down to [Install Sensor].
2. Press the <Right Arrow> key and scroll down to access the [Empty Pipe Set] option list.
3. Press the <Right Arrow> key.

4. Press the <Down Arrow> key to [Actual MTY] then press <ENTER>.

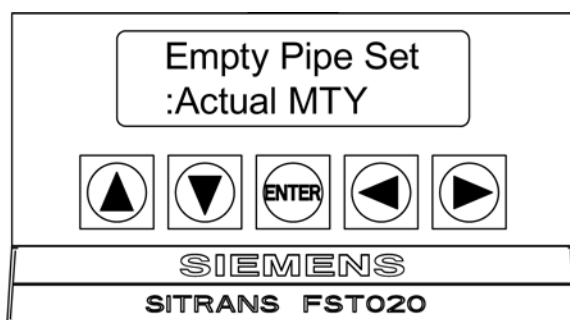

5. Empty Pipe Press [ENT] _ appears on the menu prompt lines.

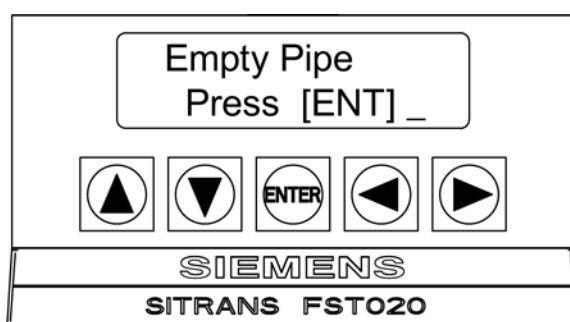

6. Empty the pipe completely, then press <ENTER>.
7. Fill Pipe Press [ENT] _ appears on the menu prompt lines.

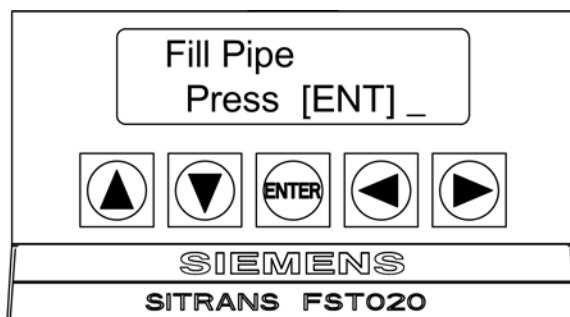

8. Refill the pipe completely, then press <ENTER>.

Using the MTYmatic command

You can repeat MTYmatic (performed during the Initial Makeup) to correct an inaccurate Actual MTY setting if conditions do not allow you to repeat the Actual Empty procedure.

Note

IMPORTANT

Only use the MTYmatic procedure when the pipe is full.

To start MTYmatic:

1. From [Channel Setup] scroll down to [Install Sensor].
2. Press the <Right Arrow> key and scroll down to access the [Empty Pipe Set] option list.

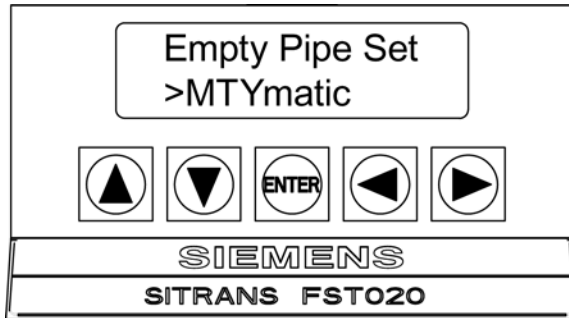

3. [MTYmatic] will be in the prompt line. (MTYmatic is the default selection.)
4. To invoke MTYmatic press <ENTER>.

Using the Set Empty command

Use [Set Empty] to enter a number that represents the signal strength level consistent with an empty pipe. [Set Empty] uses non-linear scaling. There is no direct correlation between the number you enter and any standard amplitude unit. If you set the number too low, the meter may not detect a true empty pipe. If you set it too high, it could trigger the empty pipe alarm, suspending flow measurement, even though the liquid is flowing.

To enter an Empty Pipe Alarm Threshold:

1. From [Channel Setup] scroll down to [Install Sensor].
2. Press the <Right Arrow> key and scroll down to access the [Empty Pipe Set] option list.
3. Press the <Right Arrow> key.
4. Press <Up Arrow> to move the cursor to [Set Empty].

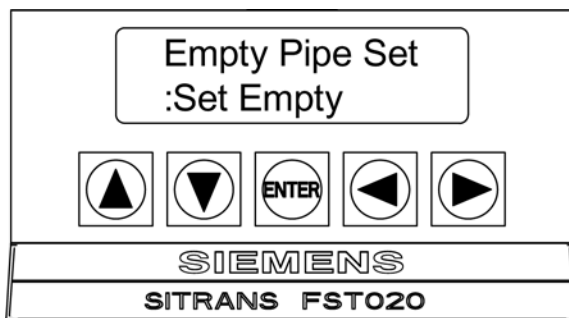

5. Press <ENTER> to view the current empty threshold number.

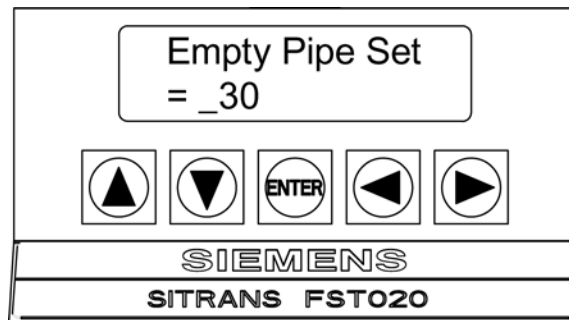

6. Use the numeric keys to type a new Set Empty number, if desired.
7. To store the Set Empty number press <ENTER>.

6.3 Installation Menus

FST020 Installation Menu Chart

Use <Left>, <Right>, <Up> and <Down> arrow buttons to navigate the menu between levels and sub menus.

For example: To navigate to [Sensor Size]:

1. Press <MENU> to return to Level A.
2. Press <Right Arrow> to Level B (Single Channel) then press <ENTER>.
3. Scroll using <Down Arrow> to [Install Sensor].
4. Press <Right Arrow> to Level D.
5. Scroll using <Down Arrow> to [Sensor Size].
6. Press <ENTER> select size from list.

Note

Menu items in bold are required entries to establish operation.

Level A	Level B	Level C	Level D (see manual)	Level E	Level F
Meter Type	Single Channel		Recall Site Setup	Enter From List	
		Channel Setup ⇒	Channel Enable	No/Yes	
			Create/Name Site	Enter From List	
			Site Security	On/Off	
			Delete Site	Enter From List	
			Save/Rename Site	Enter Name	
		Pipe Data	Pick Pipe Class	Enter From List	
			Select Pipe Size	Enter From List	
			Pipe OD (In)	Numeric Entry	
			Pipe Material	Enter From List	
			Wall Thickness	Numeric Entry	
			Liner Material	Enter From List	
			Liner Thickness	Numeric Entry	
		Application Data	Liquid Class	Select Liquid	Enter From List
				Estimated Vs M/S	Numeric Entry
				Viscosity <cS>	Numeric Entry
				Density S.G.	Numeric Entry
			Pipe Config	Enter From List	
			Anomaly Diams	Numeric Entry	
		Install Sensor	Sensor Model	Enter From List	
			Sensor Size	Enter From List	
			Sensor Mount Mode	Enter From List	
			Spacing Offset	Enter From List	
			Number Index	View Only	
			Spacing Method	View Only	
			Ltn Value <In>	View Only	
			Install Complete	No / Install	Select Install
			Empty Pipe Set	Enter From List	
			Zero Flow Adjust	Enter From List	
		Operation Adjust	Damping Control	Time Average / SmartSlew	
			Deadband Control	Numeric Entry	
			Memory/Fault Set	Fault / Memory	
			Memory Delay (s)	N/A	
		Flow Total Units	Flow Vol. Units	Enter From List	
			Flow Time Units	Enter From List	
			Flow Disp. Range	Enter From List	
			Flow Disp. Scale	Enter From List	
			Total Vol. Units	Enter From List	

Level A	Level B	Level C	Level D (see manual)	Level E	Level F
			Totalizer Scale	Enter From List	
			Total Resolution	Enter From List	
			Totalizer Mode	Enter From List	
			Batch/Sample Tot	Numeric Entry	
			Reset Totalizer	No/Yes	
		Span/Set/Cal	Span Data	Enter From List	Numeric Entry
			Set Alarm Levels	Enter From List	
			Calib. Flowrate	Intrinsic	
				Kc	
				MultiPoint	
		Logger Setup	Logger Mode	Enter From List	Logger Setup
			Logger Data	Enter From List	
			Logger Interval	Enter From List	
			Logger Events	Enter From List	
		I/O Data Control	Analog Out Setup	Enter From List	I/O Data Control
			Relay Setup	Enter From List	
			Pulse Output Setup	Enter From List	
		Diagnostic Data	Flow Data	Enter From List	Diagnostic Data
			Application Info	View Only	
			Liquid Data	View Only	
			Site Setup Data	View Only	
			Test Facilities	Enter From List	
			Print Site Setup	No/Yes	
			Site Created:	View Only	
Meter Facilities	Preferred Units	English			
		Metric			
	Table Setups	Pipe Table	Create/Edit Pipe	Enter From List	
			Delete Pipe	Enter From List	
		Sensor Type	Enter From List		
	Logger Control	Output Logger	Yes/No		
		Est LogTime Left	View Only		
		Clear Logger	Yes/No		
	Memory Control	Log Memory Left	View Only		
		Defragment	Yes/No		
	Analog Out Trim	Trim Io1	Operate / Trim @ 4mA		
	Clock Set	Date (MM.DD.YY)	Edit Date		
		Time (HH.MM)	Edit Time		

6.3 Installation Menus

Level A	Level B	Level C	Level D (see manual)	Level E	Level F
	RS-232 Setup	Data Logger Port	Baud Rate	Enter From List	
			Parity	Enter From List	
			Data Bits	7/8	
			Line Feed	Yes/No	
			Network ID	Numeric Entry	
			RTS Key Time	Enter From List	
	RS-485 Setup	Protocol	Modbus	Baud Rate	Enter From List
				Parity	Enter From List
				Word Format	Normal
					Reversed
				Address	Enter From List
			BACnet	Baud Rate	Enter From List
				Address	Enter From List
				Device Number	Numeric Entry
				Network Number	Numeric Entry
				Device Name	Enter
	System Info	Version	View Only		
		Reset Data/Time	View Only	mm.dd.yy.hh.mm.ss	
		Op System P/N	View Only		
		Checksum	View only		
		Code	View Only		
		System Time	View Only	mm.dd.yy.hh.mm.ss	
Language	Enter From List				

Functions

7.1 Selecting Flow Units

The [Flow/Total Units] menu is available after selecting a meter type and measurement channel. Use the [Flow/Total Units] menu to select volumetric flow units and an associated time base for the flow rate and total outputs. After making your selections, a view-only menu cell shows the resultant scaling. Another menu cell lets you adjust the output resolution by selecting a display range.

Selecting Flow Volume Units

The [Flow Vol. Units] option list allows you to select the rate units the flow meter uses to report volumetric or mass flow. If you select mass units, the flow meter uses the specific gravity parameter to convert volumetric flow to mass flow. The default in English Units for liquid is [Gallons].

To select a Volumetric unit:

1. From the [Meter Type] menu press the <Right Arrow> key to select [Single Channel] and then press <ENTER>.
2. The [Channel Setup] menu will appear.
3. Scroll down to the [Flow/Total Units] menu and press the <Right Arrow> key to select [Flow Vol. Units].

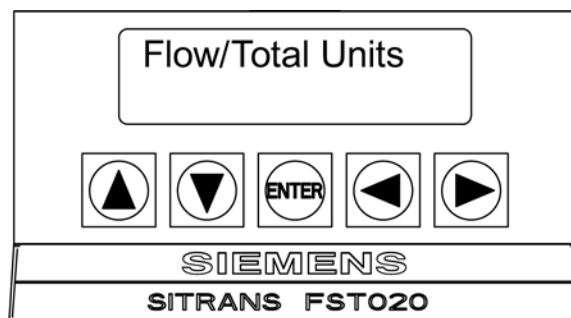

7.1 Selecting Flow Units

4. Press the <Right Arrow> key to select the option list and use the <Up/Down Arrow> keys to select the desired units.

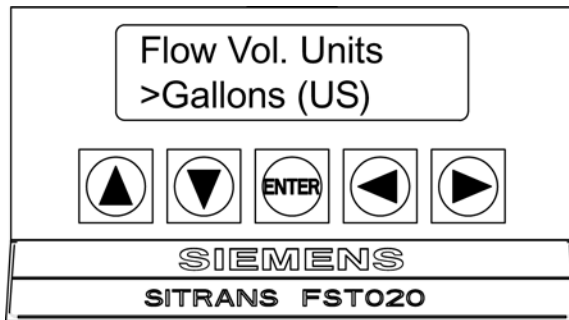

5. Press <ENTER> to store selection.
6. Repeat the similar selection procedures for the remaining Flow/Total Units menu functions:
 - Flow Time Units
 - Flow Disp. Range
 - Flow Disp. Scale
 - Total Vol. Units
 - Totalizer Scale
 - Total Resolution
 - Totalizer Mode
 - Batch/Sample Tot
 - Reset Totalizer

Totalizer Modes

The Totalizer function operates in any of the modes listed below:

Table 7- 1 Totalizer Modes

Mode	Flow Direction	Notes
POSFLOW	positive flow	Accumulates flow in positive direction only
NEGFLOW	negative flow	Accumulates flow in reverse direction only
NETFLOW	positive or negative flow	Adds to positive total; subtracts from reverse total

Note

NETFLOW (default) is best for applications where there may be zero flow for long periods. It minimizes false Totalizer register increments due to data scatter. Press the <Down Arrow> key to accept the default setting.

Selecting Totalizer modes

The Totalizer controls can only be accessed as follows:

- From the FST020 Keypad: Only the CLR TOT function is accessible from the keypad. In the [Flow/Total Units] menu, highlight the [Reset Totalizer] menu cell and select [Yes].
- From the PC board: The CLEAR (Reset Totalizer) and NOTOT (Freeze Totalizer) commands can be enabled when TB1 Pins 8 & 9 (Freeze Totalizer) and TB1 pins 11 & 12 (Reset Totalizer) are momentarily set high.
- From the RS-232 serial port

Totalizer Mode Controls

From the RS-232 Serial port all the Totalizer commands listed below can be executed using the normal PC keyboard function keys via VT100 terminal key emulation.

Note

Si-Ware or HyperTerminal should be in the Data Display mode when invoking the function keys referenced in the table below. Use the key sequence Ctrl L to display the Data Display mode.

Communications Setup

Connect the FST020 to your PC. Refer to Appendix A RS-232 Connection (Page 21), if needed.

1. Access Si-Ware or, if using a PC, access HyperTerminal from the PC [Programs] menu, then select [HyperTerminal].
2. In [Connection Description] dialog box, enter a connection name (e.g. FST020). Click [OK].
3. In [Phone Number] dialog box, select [Direct to COM 1 (or COM 2)]. Click [OK] to select.
4. In [Properties] dialog box, enter RS-232 parameters. Click [OK].
5. At terminal screen, click [File]. Select [Properties].
6. Select [Settings] tab. At [Emulation] box, select [VT-100].
7. Select [ASCII Setup]. In [ASCII Sending] uncheck boxes. In [ASCII Receiving] check [Append line feeds to incoming line ends.]. Click [OK].

Functions

7.1 Selecting Flow Units

8. At the Terminal screen, press <ENTER> and the Data Display mode appears.
9. If not, to enter the Data Display mode type MENU and then press <Ctrl L>.

Table 7- 2 Totalizer Controls

Key	PC #	Command	Description
F1	1	CLRTOT (also clears overflow)	Resetting the Totalizer registers clears all total data accumulated during operation. Note: The Clear Totalizer function (CLRTOT) can only be invoked from an external PC keyboard via the RS-232 serial port. Also invoked using digital input pins TB1-11 and TB1-12. Commands that can be invoked from Si-Ware or HyperTerminal: Terminal Command: CLRTOT 1
F1	2	NOTOT (Totalizer Freeze)	Invoking the NOTOT command disables the Totalizer. Totalization will not resume until you repeat the F1 and numeric 2 key sequence. Commands that can be invoked from Si-Ware or HyperTerminal: Terminal Command: NOTOT 2 = Stop Totalizer Terminal Command: NOTOT 2 = Starts Totalizer
F1	3	LAPTOT (Totalizer snapshot)	The LAPTOT command freezes the Totalizer screen display. However, the flow meter will continue to update its internal registers. The flow meter will show the current total when you repeat the F1 and numeric 3 key sequence. When you activate LAPTOT, an L precedes the TOTAL symbol (i.e., [LTOTAL]) on the PC HyperTerminal screen.
F1	4	CLEAR (Batch/Tot register)	Clears the Batch/Sample Totalizer register. The flow meter maintains a separate Totalizer register for Batching or Sampling applications but cannot be accessed directly. It is used for relay control only. If you assign the system relay to this function, a momentary (50 ms) relay pulse occurs whenever the BATCHTOT register accumulates a specified liquid quantity. In the [Batch/Sample Tot] menu cell the required total flow volume is entered to activate the relay. This numeric entry must reflect the selected flow total units. The [Totalizer Scale] menu cell shows the applicable flow total units. The sign of the Batch/Sample Total determines positive or negative accumulation.
F1	6	CLEAR (Makeup Latch)	Clears the Makeup Latch. Refer to the Span Data menu [Set Alarms] and then the [Makeup Latch] On / Off option.

The flow meter stores positive and negative accumulations in separate independent registers. Use the PC keyboard and numeric keys to control the flow Totalizer registers.

7.2 Zero Flow Adjust Menu

Zero Flow Compensation Methods

Unlike turbine flow meters ultrasonic transit-time flow meters provide active flow measurement right down to zero flow, however, the measurement of the transit-time delta is dependent on the similarity or "match" of the electronics, cables and ultrasonic sensors. Consequently some flow offset (or zero offset) may be present in any installation. To eliminate this residual zero offset Siemens has developed several different methods to insure proper zero flow compensation. The following paragraphs describe each method and when they should be used.

AutoZero

When the 1011HP sensors are mounted in the Reflect Mode configuration the AutoZero routine is automatically invoked at the end of the Initial Makeup. Flow does not have to be stopped to perform AutoZero since only the pipe wall signal is used in determining the zero offset and not the liquid component. The AutoZero routine performs a one-time analysis of the pipe wall component of the ultrasound signal to quantify any residual mismatch in the hardware. Once the AutoZero routine is complete, the system memorizes this measured zero offset and subtracts this value from the flow reading.

Actual Zero

The Actual Zero function simply averages the indicated "zero flow" readings (over a user defined time period) then stores this average value in memory. Under normal operation the indicated flow reading is zero compensated by simply subtracting this memorized value from the uncompensated flow reading. Actual Zero is the most positive method for zeroing the system; however, flow must be stopped with the line blocked (if possible) before invoking this function. If stopping flow is not possible then an alternate zeroing method should be selected.

ReversaMatic

This routine involves swapping the Up and Down sensors on the pipe (while keeping the cables attached) such that the difference in the transit-time change represents the zero offset. The fixed zero offset value is stored in memory in the same manner as described in Actual Zero. This routine would generally be used whenever flow cannot be stopped and the sensors cannot be mounted in the Reflect Mode configuration. Flow must be stable during the entire process.

ZeroMatic

When ZeroMatic is invoked the flow meter first performs the same analysis as described above in the AutoZero routine. However, after this analysis is complete the flow meter continues to interrogate the pipe wall signal and update the zero offset value under normal operation, such that the flow meter dynamically compensates for changing conditions which would normally result in zero drift. ZeroMatic will only operate with the sensors mounted in the Reflect Mode configuration and is recommended for applications which experience large temperature extremes.

Note

Invoking ZeroMatic will clear any existing "fixed" or memorized zero offset. If any zero offset remains after flow is stopped, an Actual Zero can be performed without interrupting ZeroMatic operation. To disable ZeroMatic, invoke it again, but then press <Left Arrow> to abort the installation.

Note

The ZeroClr command only resets the memorized zero offset registers not those set when the ZeroMatic routine is invoked.

Using Actual Zero

Note

Flow must be stopped with the line blocked (if possible) before invoking this function.

To invoke Actual Zero:

1. From the [Install Sensor] menu, scroll down to [Zero Flow Adjust].
 2. Access the [Zero Flow Adjust] option list by pressing the <Right Arrow> key.
 3. Press <ENTER>. Set the current flow rate (in selected rate units) to equal zero (0.000).
-

Note

If a flow offset is desired (i.e., to test analog outputs) then press <Right Arrow> key to enable numeric entry.

4. Press <ENTER> to start the Actual Zero process.

When you send the command, the flow meter analyzes the current flow rate for up to sixty seconds, integrating (averaging) the data for the best zero correlation. During this time, the menu prompt at the top of the display screen shows a timer that counts from zero to sixty. You can allow zero averaging for the entire period, or cancel the process at any time by pressing the <ENTER> key. This controls the amount of data the flow meter averages to obtain a zero level.

Using ReversaMatic

If site conditions do not permit stopping the flow rate at the mounting location, and you do not know the current flow rate, then you can use the ReversaMatic routine to establish the zero flow level. You should perform the ReversaMatic procedure as quickly as possible to ensure that the flow rate remains constant throughout the procedure.

To invoke ReversaMatic:

1. From the [Install Sensor] menu, scroll down to [Zero Flow Adjust].
2. To access the [ReversaMatic] option press <Right Arrow> key and then scroll to [ReversaMatic].
3. Press <ENTER> to invoke the routine.
4. The flow meter begins to measure the positive flow rate. "Positive" flow refers to flow moving from upstream sensor location to the downstream sensor location. Note top prompt line shows: **Reversamatic Action**
5. Upon completion, the flow meter beeps and the display screen shows: **Reverse Sensors / Press <ENTER>**
6. Now remove then remount the upstream and downstream sensors in their reversed positions. Mount the Up sensor (without removing its cable) in the Down sensor/cable location. Mount Down sensor with its cable in the Up sensor/cable location. When remounting the sensors, couple them to the pipe properly. Press <ENTER> (after re-installing the sensors).
7. The flow meter measures the negative flow rate briefly, then beeps and repeats the prompt: **Reverse Sensors / Press <ENTER>**
8. Now remount the sensors for normal operation (in their original orientation). When remounting sensors, couple them to the pipe properly. Press <ENTER> (after re-installing the sensors).

This completes the ReversaMatic procedure. The system's zero accuracy will be very close to that obtainable using the Actual Zero method, providing flow remained constant during this procedure.

NOTICE

Preventing Flow Mis-Registration

A caution on the use of upper and lower flow limits (used to prevent flow mis-registration) prior to using the Reversal Zero technique (ReversaMatic): If the negative flow rate that the flow meter reads in the step during which the sensors are reversed is more negative than the lower flow limit, the meter will re-register positive and the Reversal Zero cycle will thus be corrupted.

Therefore, postpone the installation of upper and lower flow limits until the reversal zero procedure is executed successfully. For pipes that combine large diameters with very high flow velocities, it may be necessary to move the upper and lower flow limits out of the way until the reversal zero is completed. Moreover, pipes of this size frequently have excellent intrinsic zero performance and may not even need zeroing.

ZeroMatic

Note

ZeroMatic is used in the Reflect Mode only. Invoking ZeroMatic clears any existing fixed zero offset.

Use this menu cell to select the ZeroMatic option. If conditions permit the use of the Auto Zero function then the ZeroMatic option can be used as well.

To select and enable the ZeroMatic option:

1. In the [Install Sensor] menu, press <Right Arrow> key and scroll to the [Zero Flow Adjust] menu cell.
2. To access the [Zero Flow Adjust] option list press <Right Arrow> key.

Note

If ZeroMatic is not running, the [Actual Zero] menu item will be displayed next to the [Zero Flow Adjust] menu cell.

3. Select the [ZeroMatic] menu cell by pressing <Up/Down Arrow> then press <ENTER>.

When the Initial Makeup of ZeroMatic is complete the screen will return to the [Install Sensor] menu and automatically scroll to [Operation Adjust], which is the next menu cell.

To disable the ZeroMatic function:

1. Select the [Install Sensor] menu cell again.
2. Scroll down to the [Zero Flow Adjust] menu cell by pressing <Up/Down Arrow>.

Note

The highlighted [ZeroMatic] menu item is the only indication that ZeroMatic is functioning.

3. Invoke the ZeroMatic initial makeup procedure as previously described above.
4. While ZeroMatic initial makeup is running, press <Left Arrow> to abort the process thereby disabling the function.
5. The screen will return to the [Zero Flow Adjust] menu cell.

7.3 Span Data

The Span Data menu allows you to set 0% and 100% output limits for volumetric flow (Vfo), absolute flow (Vfab) and sonic velocity (Vs). Each menu cell shows appropriate rate units and time base. If you change flow rate units after spanning the system, the flow meter automatically updates the output data setup to reflect the change. Span limits apply to the one analog output. The flow output operates as follows:

<p>Vfo <i>Spanned Volumetric:</i></p>	<p>The minimum and maximum flow rate entries establish the Vfo span. The Max Flow menu cell sets 100% of span. The Min Flow menu cell sets 0% of span. Use signed numbers for bi-directional spanning. Note that negative (reverse) flow always is lower than positive flow, whatever its absolute magnitude. For example, for a flow measurement range of -30 GPM to +10 GPM, the 4mA span will be -30 GPM, and the 20mA span will be +10 GPM.</p>
<p>Vfab <i>Spanned Absolute Volumetric Flow Rate:</i></p>	<p>Vfab is the absolute magnitude of the volumetric flow rate (Vfo). There are no menu cells provided to span this output. Vfab shares the Vfo span entries. The Vfab minimum span is always zero. The maximum span for Vfab is the largest absolute value of either the min. or the max. flow rate (Vfo) entries. For example, a span between +10 GPM and -30 GPM, spans the Vfab output from 0 GPM to 30 GPM.</p>
<p>Vs <i>Spanned liquid sonic Velocity:</i></p>	<p>Vs is the sonic velocity in meters-per-second (m/s) of the flowing liquid. The min. and max. Vs entries establish the Vs span. Max Vs (m/s) defines 100% of span. The Min Vs (m/s) defines 0% of span.</p>

Maximum span values represent:	Minimum span values represent:
<p>100% of span Current output of 20mA Pulse output of 5000 Hz</p>	<p>0% of span Current output of 4mA Pulse output of 0 Hz</p>

To change the default Span Data settings:

1. At [Meter Type], press <Right Arrow> key to [Single Channel] and press <ENTER>.
2. Scroll down to [Span/Set/Cal] and press <Right Arrow> key.

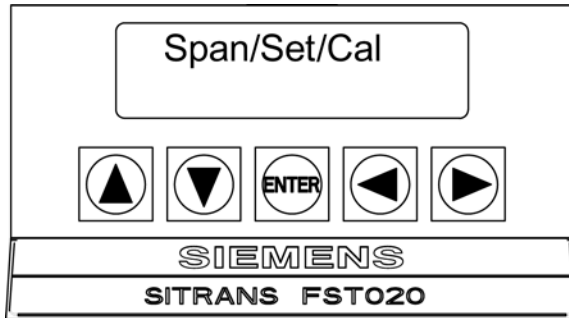

3. At [Span Data] press the <Right Arrow> key again.
4. Press <Down Arrow> to scroll to [Max Flow GAL/MIN]. Press <Right Arrow> key. Input 100% flow rate numeric data for 20mA. Press <ENTER> to store data.

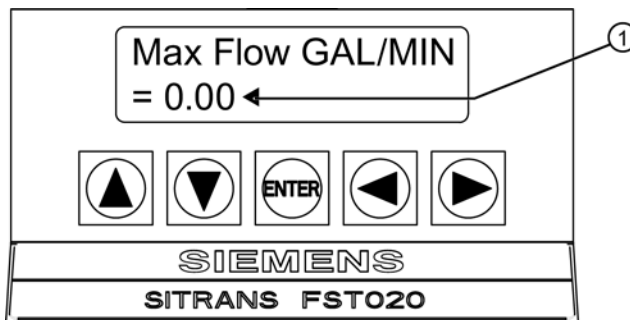

① Input numeric flow data here

5. [Min Flow GAL/MIN] will appear. Press <Right Arrow> key to input 0% flow rate numeric data for 4mA. Press <ENTER> to store data.

7.4 Logger Control

Logger Control Menu

The [Logger Control] menu in the [Meter Facilities] menu provides the Logger controls for the flow meter measurement channel. It allows the user to select data items/alarm events, a logging interval and a destination for Logger reports.

Table 7- 3 Logger Control Menu Option List

Logger Control	Output Logger	No Yes
	Est LogTime Left	-- ;--
	Clear Logger	No Yes

Output Logger

The [Output Logger] command sends data to an external device via the RS-232 serial port.

Est Logtime Left

The [Est LogTime Left] view-only menu cell shows an estimate of the hours and minutes of logging time remaining.

Clear Logger

The [Clear Logger] command erases the entire Logger file.

Output Logger Selection

This menu cell allows you to send the Logger contents to an external device (usually a computer or printer) via the flow meter's RS-232 Serial I/O port. This command is effective only after a successful install. In addition, you have to enable datalogging and select data items in the [Logger Setup] menu.

The flow meter interfaces with most serial printers or personal computers for Logger printouts. You must use the proper cabling between the flow meter and the external device. In addition, you must configure the RS-232 Setup correctly. You should turn off the Logger function before you transmit an extensive printout. This will avoid contaminating the printout with new Logger data. Logger reports are sequential ASCII text files.

To send Logger contents to the RS-232 Serial Port:

1. Check the flow meter-to-external device connections and your RS-232 Setup parameters. In needed, refer to RS-232 Connection (Page 21).
2. From the [Single Channel] menu press the <Right Arrow> and then <ENTER> key.

3. Press the <Down Arrow> key to the [Meter Facilities] menu.
4. From the [Meter Facilities] menu press the <Right Arrow> key and scroll down to the [Logger Control] menu.

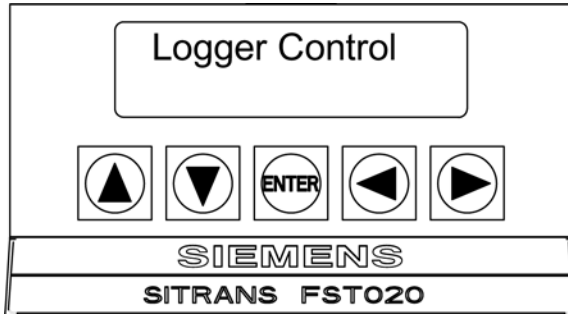

5. To access the [Output Logger] menu cell press the <Right Arrow> key and again to access the option list.
6. Scroll to [Yes] by pressing <Up/Down Arrow> key.

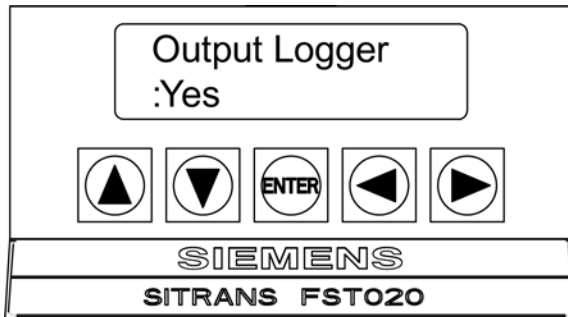

7. To transmit Logger contents to external device via the serial port press <ENTER>.
8. To stop printout press <Left Arrow> key.

Selecting Est LogTime Left

Est LogTime Left is a "view-only" menu cell that shows an estimate of the amount of Logger time remaining in hours and minutes. This menu cell becomes active after you enable datalogging. The time is an estimated minimum since data compression is employed for improved storage efficiency.

From the [Output Logger] menu cell, press the <Down Arrow> to view the [Est LogTime Left] data.

Clear Logger

If you use the Logger in its default mode, eventually you will use all the memory available for Logger storage. When this occurs, you will not be able to log more data until you free up the memory. The [Clear Logger] command erases ALL stored Logger data. Therefore, you should evaluate the currently stored data and print any valuable information before using this command.

Note

Saved Sites also consume Logger RAM.

Clearing Logger Memory

1. From the [Est LogTime Left] menu cell, press the <Down Arrow> key.
2. To access the [Clear Logger] option list press <Right Arrow> key.
3. Scroll to [Yes] by pressing the <Up/Down Arrow> keys.

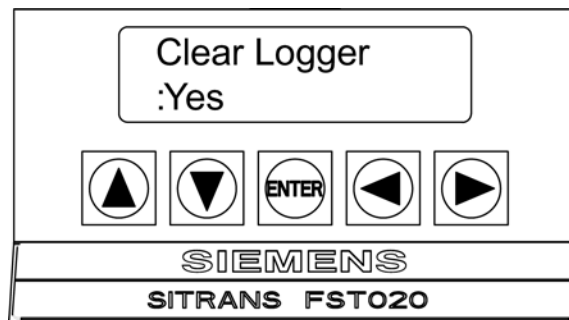

4. To clear the memory press <ENTER> key.

7.5 Operation Adjust Menu Settings

Introduction

The [Operation Adjust] menu becomes available after the meter type and measurement channel are active. It is recommended that you use it after the sensors are installed and operating to "fine-tune" the meter's output characteristics.

Each application presents different data display and output requirements due to unique pipe and liquid conditions. Use the [Operation Adjust] menu to match flow meter operation to the site. You can set damping controls for the primary flow rate output. You can define a Deadband, (usually a very low flow rate), below which the flow output will be forced to zero. You can also select the flow meter response to a continuous Fault condition.

Table 7- 4 Operation Adjust Menu

Operation Adjust	Damping Control ⇒	Time Average xx.x (numeric entry) SmartSlew x (numeric selection)
	Deadband Control ⇒	x.xx (numeric entry)
	Memory/Fault Set ⇒	Memory Fault
	Memory Delay (s) ⇒	xxx (numeric entry)

Damping Control

The flow meter provides two different data output filter types, Time Average and SmartSlew. Time Average (recommended) integrates the instantaneous flow rate over a selectable time period. Use the Time Average function when stability in flow reading is essential. A value entered (in seconds) sets the time it takes the flow meter to respond to a rate change. The default is 10 seconds. Enter any amount of time up to 60 seconds maximum.

SmartSlew performs data scatter damping during steady flow periods while maintaining the ability to respond to changing flow rates. SmartSlew values range from [1 to 9]. Pick a higher number to slow flow meter response to a rate change.

Setting the Time Average (default):

1. From the [Single Channel] menu press the <Right Arrow> and then <ENTER>.
2. Scroll to the [Operation Adjust] menu and press <Right Arrow>.
3. At the [Damping Control] menu press the <Right Arrow> to [Time Average] and then again.

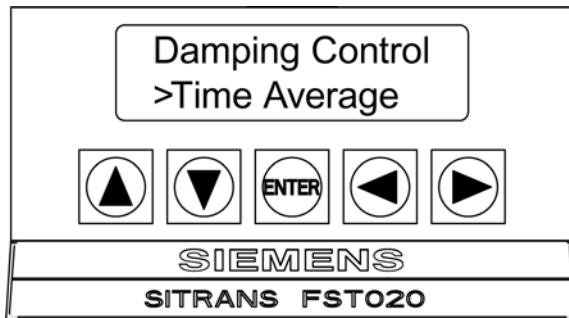

4. To enable Time Average entry press <Right Arrow>.
5. Use the keypad keys to type the new Time Average setting.
6. To register the new value press <ENTER>.

Setting SmartSlew :

1. From the [Single Channel] menu press the <Right Arrow> and then <ENTER>.
2. Scroll to the [Operation Adjust] menu and press <Right Arrow>.
3. At the [Damping Control] menu press the <Right Arrow> and scroll to [SmartSlew] and press <ENTER>.

4. To access [SmartSlew] option list press <Right Arrow>.
5. Use the keypad keys to type the new SmartSlew setting.
6. To register the new value press <ENTER>.

Deadband Control

Use the Deadband Control to instruct the flow meter to report zero flow if the flow rate falls below a specified level (usually a very low rate). It will prevent the possibility of data scatter (a natural result of digital computation) from causing false Totalizer accumulation during long non-flowing periods. Inspect the actual data scatter during zero flow conditions to find the proper Deadband setting for your application.

To edit Deadband default setting (0.000):

1. From the [Single Channel] menu press the <Right Arrow> and then <ENTER>.
2. Scroll to the [Operation Adjust] menu and press <Right Arrow>.
3. Scroll to the [Deadband Control] menu.
4. Press <Right Arrow> to enable numeric entry.
5. Use the keypad keys to type in the desired rate (using selected flow rate units).
6. To register the new value press <ENTER>.

Memory/Fault Set

Certain situations will interrupt data production (e.g., an empty pipe or excessive aeration). Use Memory/Fault Set to select the flow meter response to such an interruption. The Fault setting (default) will zero the flow rate output and declare an alarm on the flow display screen, the Datalogger report and an assigned relay output.

For some applications, occasional temporary Fault conditions may be a normal part of the process and would not require an alarm response. The flow meter offers a Memory operating mode to support such an application. Memory Mode suspends the flow meter Fault response by preventing the flow outputs from dropping to zero for the interval specified in the [Memory Delay] menu cell. During the Memory duration, the flow meter will maintain the last valid flow reading measured before the onset of the fault condition. The default Memory Delay is 60 seconds. You may select any duration from 3 to 604,800 seconds (one week).

Selecting Memory Mode

1. From the [Single Channel] menu press the <Right Arrow> and then <ENTER>.
2. Scroll to the [Operation Adjust] menu and press <Right Arrow>.
3. Scroll to the [Memory/Fault Set] and press <Right Arrow> to access option list.
4. Scroll to [Memory] by pressing <Up/Down Arrow>.
5. To make selection press <ENTER>.
6. The [Memory Delay (s)] menu cell appears.

Memory Delay (s)

The [Memory Delay (s)] menu cell allows you to specify the number of seconds that the flow meter maintains its last valid flow reading. When the memory delay expires, it triggers the fault alarm response described previously.

Setting Memory Delay

1. To enable numeric entry press <Right Arrow>.
2. Use the keypad keys to type the delay in seconds.
3. To register the new value press <ENTER>.

7.6 Analog Out Setup

The flowmeter provides current, voltage and pulse-rate analog outputs. The [Analog Out Setup] menu allows you to assign data functions for these signals. The transmitter terminal strip contains the analog output terminals.

Table 7- 5 Analog Outputs

Io (Isolated Current)	4 to 20mA varies in proportion to an assigned data function.
-----------------------	--

Table 7- 6 Analog Out Setup Data Categories

Vfo	Spanned volumetric/mass flow
Vfab	Spanned unsigned flow magnitude
Vs	Spanned liquid sonic velocity
Valc	Receive signal amplitude
Vaer	Relative degree of liquid aeration/cavitation

Note

Refer to Appendix A (Page 127) for Analog output connections.

Io Output Functions

The Io analog output is a loop-powered (or externally powered), isolated 4-20mA DC signal that varies linearly in relation to a selected data function.

This output also provides a fault indication by dropping to 2mA if assigned to flow rate and under fault conditions.

Assigning a function to the current output:

1. From the [Single Channel] menu press the <Right Arrow> key and scroll down to [I/O Data Control].

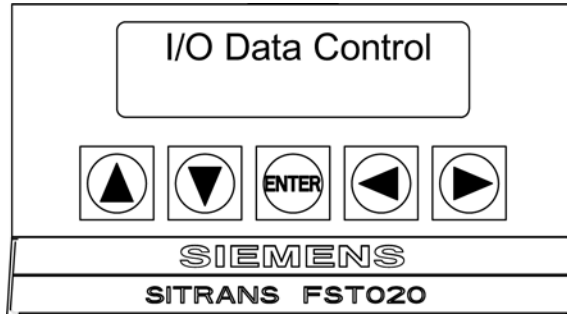

2. Press <Right Arrow> key to access the [Analog Out Setup] menu.
3. Press <Right Arrow> key twice to access the [Io1] option list.

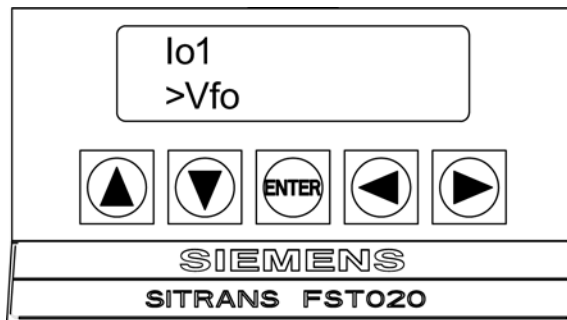

4. Scroll to the desired data function by pressing <Up/Down Arrow> keys.
5. To store selection press <ENTER>.

7.7 Setting Relays

Use the [Relay Setup] menu to assign a function to channel relays. The flow meter supports two types of relay outputs, Alarm Relay and Pulse Relay. Alarm Relay outputs operate in "fail-safe" mode. The relay(s) are energized under normal conditions - an alarm condition causes the relay(s) to de-energize until the alarm clears. The Pulse Relay output supports batch relay functions with an output pulse width of approximately 50 ms; maximum activation rate is 2.5 pulses per sec. If Totalizer pulses exceed this rate, excess pulses are stored in an overflow register. This allows the relay to "catch up" when flow decreases enough.

Note

The Reset Totalizer [Yes/No] menu command clears all channel Totalizers plus the overflow register described above.

Relay 1 Function Assignments

The flow meter provides one alarm relay. Please refer to the Appendix A (Page 127) for wiring details. Relays respond to any of the alarm conditions or data functions included on the Relay 1 option list.

Table 7- 7 Relay 1 Option List

Not Used	Not Active
Power Off	Power Off alarm occurs when power fails.
High Flow	Flow rate exceeds high flow set point.
Low Flow	Flow rate falls below low flow set point.
Flow Alarm	Flow rate exceeds or falls below flow set points.
Fault Alarm	System loses receive signal (all paths in fault).
Soft Fault	Fault condition - memory mode active.
Spacing	Sensor spacing needs adjusting.
Empty	Empty pipe alarm.
Aeration	Aeration percentage exceeds alarm set point.
Interface	Liquid interface setpoint exceeded.
Reverse Flow	Flow is in negative direction.
Batch Tot	Batch/Sample total advances.

Assigning functions to Relay 1:

1. From the [Single Channel] menu press the <Right Arrow> key and scroll down to [I/O Data Control].
2. Press <Right Arrow> key and scroll down to [Relay Setup].

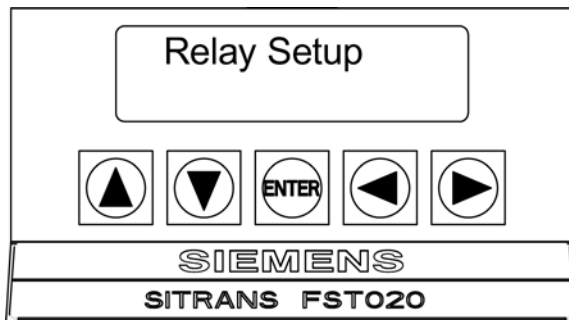

3. Press <Right Arrow> key to access the [Relay 1]. Press <Right Arrow> key again to access the option list.

4. Press the <Up/Down Arrow> keys to the desired Relay assignment.

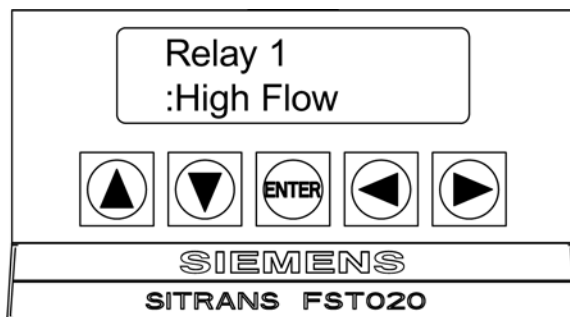

5. To store selection press <ENTER> key.

7.8 Pulse Out Setup

The flow meter pulse output can be configured for either a pulse output or a frequency output.

- Batch Tot - When the system relay is assigned to this function, a momentary (50 ms) relay pulse occurs whenever the BATCHTOT register accumulates a specified liquid quantity.
- PGEN - a frequency that can be programmed for a specific number of pulses/unit volume.
- Pos Total and Neg Total - POSTOT or NEGTOT pulse that represents volume as indicated by the Least Significant Digit (LSD) of the Totalizer Display.

The pulse output is accessed at terminals TB1-14, TB1-15 and TB16 (GND) and is loop-powered (30 VDC Max). Refer to the terminal block wiring diagram shown below.

7.8 Pulse Out Setup

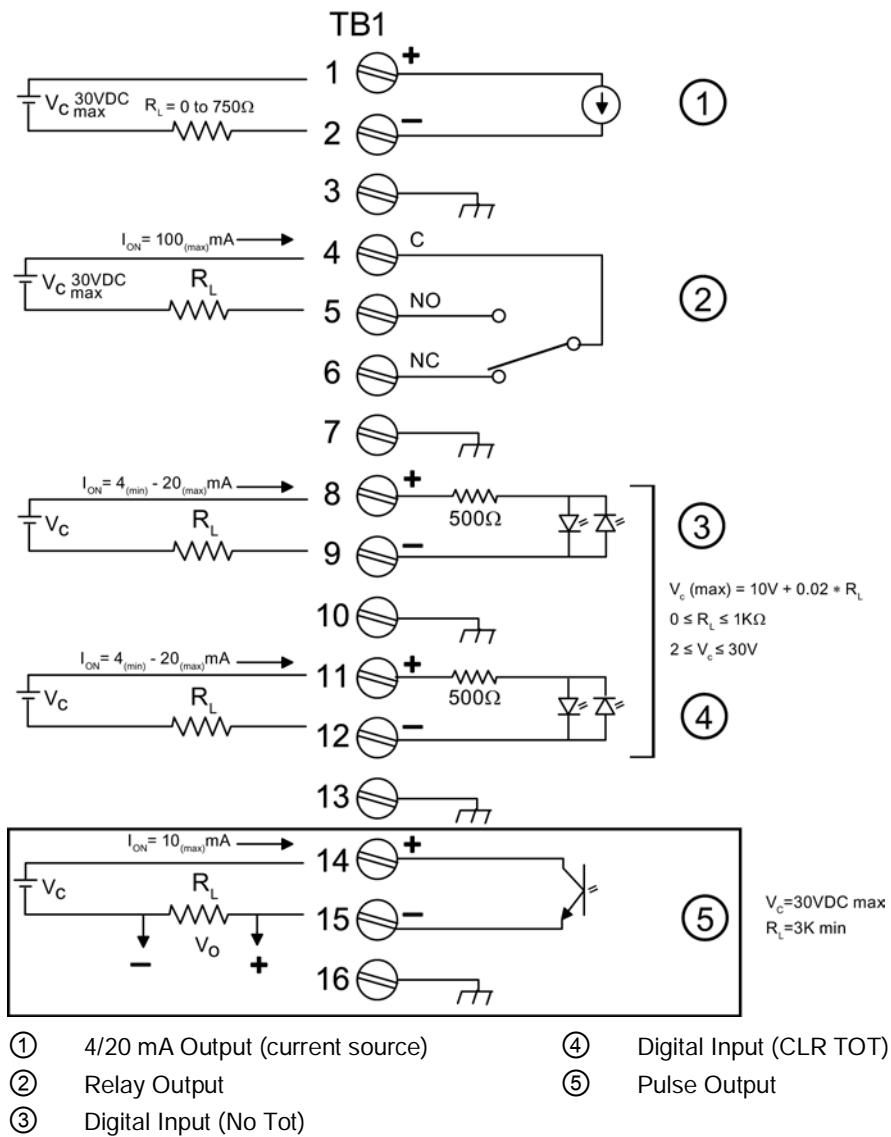
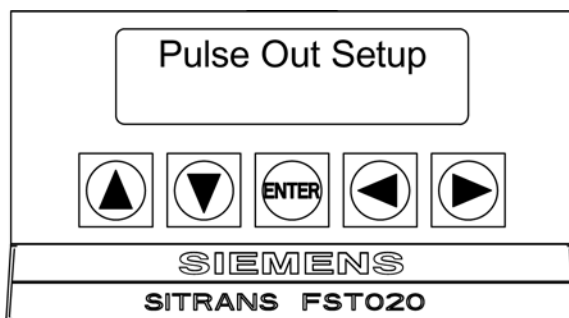

Figure 7-1 FST020 Output Wiring Terminals

Pulse Out Setup

The pulse output programming setup is accessed in the [I/O Data Control] menu.

1. From the [Single Channel] menu press the <Right Arrow> key and scroll down to [I/O Data Control].
2. Press the <Right Arrow> key and scroll down to [Pulse Out Setup].



3. Press the <Right Arrow> key to [PGEN] (default setting) for frequency pulses/unit volume.
4. To choose Totalizer pulses, press the <Right Arrow> key and then the <Down Arrow> key as needed to select [Pos Total] or [Neg Total] for single pulses per volume unit.
5. Press <ENTER> to save selection.
6. To set the frequency span, press the <Left Arrow> twice to access the [I/O Data Control] menu and then scroll up to the [Span/Set/Cal] menu.

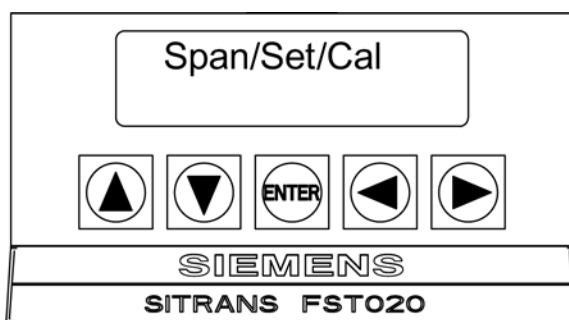

7. Press the <right Arrow> to select [Span Data].

Note

The volumetric units (e.g. gallons, liters, etc.) must be selected in the [Flow/Total Units] menu. The units in the following example are GAL (US).

8. Press the <Right Arrow> key to select [PGEN P/GAL]. Press the <Right Arrow> key again.

9. Use the <Up/Down Arrow> and <Left/Right Arrow> keys to program the desired pulses per gallon.

Note

Make sure to select a pulse value that will ensure a pulse rate of at least 20 pulses per second (20 Hz) at your lowest flow rate or data will be lost. PGEN produces a 50/50 duty cycle pulse output; therefore the pulse width is relative to the pulse rate at any given time.

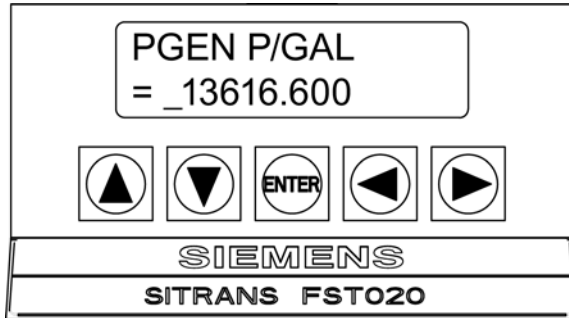

10. Press <ENTER> to save the new entry.

Totalizer Pulse Scaling

When pulse rates are required for counting, sampling, batching, etc., the Totalizer pulse can be selected. The FST020 offers a pulse output relative to either the positive flow direction Totalizer or the negative flow direction Totalizer. The Totalizer pulse output will produce 1 pulse each time the Least Significant Digit (LSD) of the Totalizer increments.

To program the desired pulse volume the user must configure the Totalizer scale and resolution settings to set the LSD of the Totalizer equal to the pulse volume desired. These settings are performed in the [Flow/Total Units] menu.

1. From the [Single Channel] menu press the <Right Arrow> key and scroll down to [Flow/Total Units].

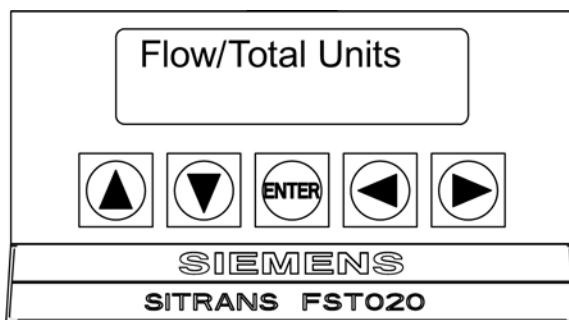

2. Press the <Right Arrow> key then scroll down to select [Total Vol. Units]. Press the <Right Arrow> key and then the <Up/Down Arrow> keys to select the desired units.

- For example, to set units for gallons select [Gallons (US)] and press [ENTER].

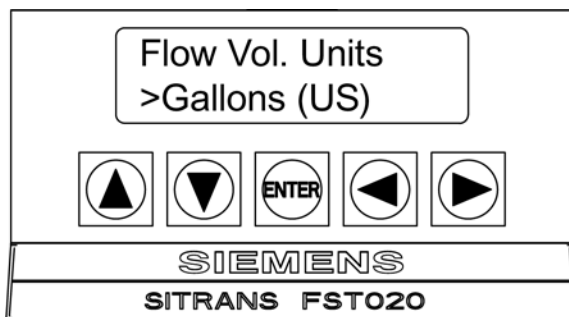

Note

Set Totalizer Scale and resolution so that the LSD equals the required volume/pulse. Refer to Table 1-1 below.

- Scroll down to [Totalizer Scale]. For example, to select [KGAL] press the <Right Arrow> key and then the <Down Arrow> key.
- Press < ENTER > to save selection.

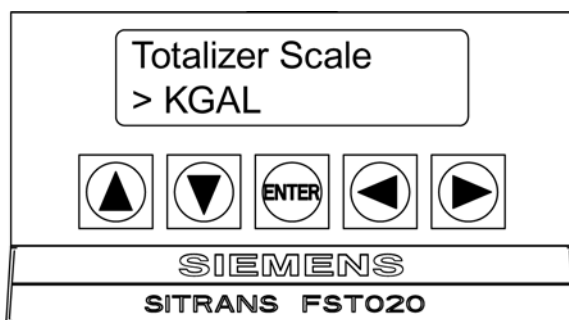

- The [Total Resolution] menu will now be displayed (x = decimal point).

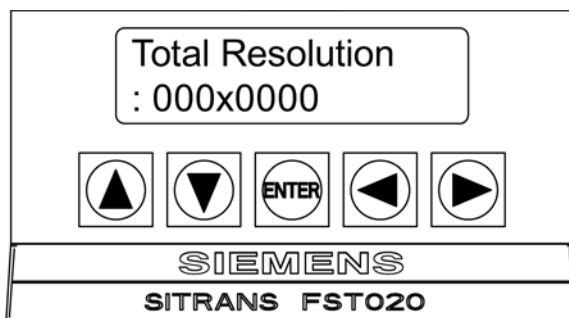

- Press the <Right Arrow> key and then the <Down Arrow> key to select the desired resolution.
- Press <ENTER> to save selection.

7.9 Memory Control

Table 7- 8 Pulse Output Values for Gallons (US)

Totalizer Volume Units	Totalizer Resolution	Totalizer Represents GAL/Pulse
Gallons	000x0000	0.0001 Gallons / pulse
Gallons	0000x000	0.001 Gallons / pulse
Gallons	00000x00	0.01 Gallons / pulse
K Gallons	000x0000	0.1 Gallons / pulse
K Gallons	0000x000	1 Gallon / pulse
K Gallons	00000x00	10 Gallons / pulse
M Gallons	000x0000	100 Gallons / pulse
M Gallons	0000x000	1000 Gallons / pulse
M Gallons	00000x00	10000 Gallons / pulse

Note
IMPORTANT

Totalizer pulse output conditions:

1. FST020 flow meters with firmware version 2.04.04 have an ON pulse width of 50 milliseconds and a maximum output pulse rate of 2.5 Hz. If the instantaneous rate exceeds 2.5 Hz, output pulses will be buffered in memory and will be outputted when the rate drops below 2.5 Hz.
2. FST020 flow meters with firmware version 2.04.05 have an ON pulse of 10 milliseconds and a maximum average output pulse rate of 50 Hz. If the instantaneous rate exceeds 50 Hz, output pulses will be buffered in memory and will be outputted when the rate drops below 50 Hz.

7.9 Memory Control

Introduction

Memory Control is a reference menu that shows the amount of bytes of data memory left. The data memory capacity depends on the number and complexity of the site setups stored in memory and the size of the current Datalogger file. The [Memory Control] menu is located within the [Meter Facilities] menu.

Table 7- 9 Memory Control Menu

Log Memory Left→	XXXXXXX
Defragment→	No Yes

Log Memory Left

This view only menu cell shows the minimum remaining number of characters available for Datalogger and site storage.

Defragment

Selecting YES for this item consolidates memory data blocks into contiguous storage; collapsing the filler regions. You may be able to use an additional block for site or Datalogger storage as a result. Use this command if you seem to be out of memory even though the [Log Memory Left] item indicates free capacity.

To access the [Memory Control] menu cells:

1. From the [Meter Type] menu scroll down to the [Meter Facilities] menu
2. Press the <Right Arrow> key and then scroll to the [Memory Control] menu.

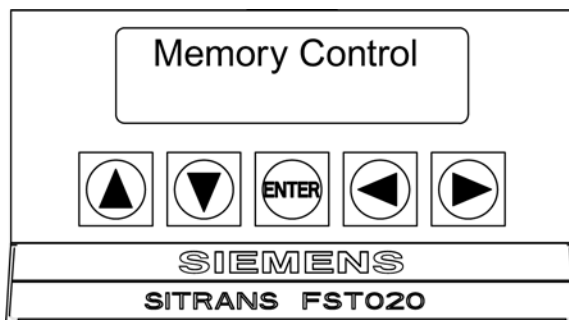

3. Press the <Right Arrow> key to access the [Log Memory Left] menu cell and view the data memory bytes available.
4. Press the <Down Arrow> key to select the [Defragment] menu.
5. To select [Yes] press the <Right Arrow> and then <ENTER> key.

7.10 Analog Output Trim

Introduction

Analog Out Trim function allows fine-tuning of the flow meter's analog current output using an ammeter connected to the output under test.

Table 7- 10 Analog Out Trim Menu Structure

Analog Out Trim	Io1	Operate Trim@4mA Indicated mA=x.xx
-----------------	-----	---------------------------------------

Note

The current trimming is limited by the 12-bit resolution of the flow meter's D/A Converter (DAC).

Current Output Trim Io1

Note

Can be trimmed to within .005mA of nominal.

To calibrate a current output:

1. From the [Meter Type] menu scroll down to the [Meter Facilities] menu.
2. From the [Meter Facilities] menu, scroll to the [Analog Out Trim] menu and press the <Right Arrow> key.

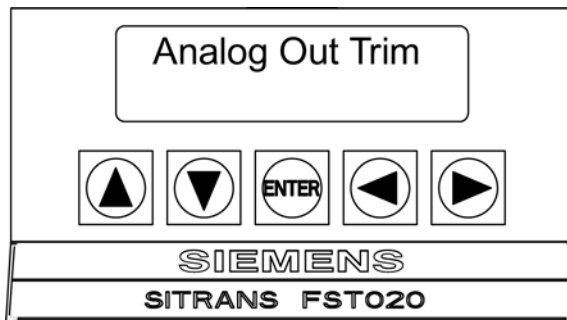

3. Press the <Right Arrow> key to access the option list.
4. Set up an ammeter to read Amps, then connect it to the supply and return terminals of the current output under test.
5. Press the <Up/Down Arrow> keys to select [Trim @ 4mA].

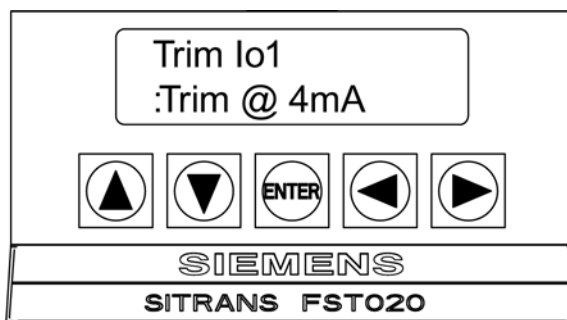

6. Press <ENTER>. The ammeter should now be reading 4.00mA.

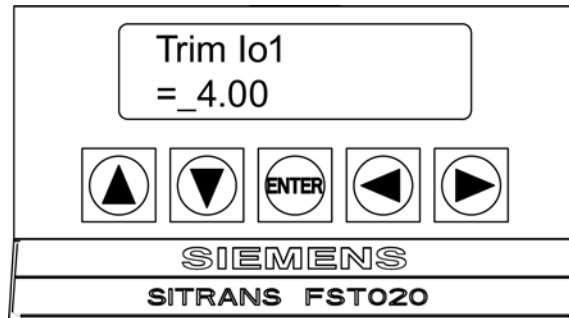

7. If the ammeter reading does not match, use the keypad keys to type in the current reading.
8. Press <ENTER> to register setting. This adjusts the flow meter's DAC (digital-to-analog converter) so that a 4mA output corresponds with 4mA on the ammeter.
9. Check the ammeter again to make sure that it is now reading 4mA.

Alarm, error and system messages

8.1 Alarm Codes

Letter Code	Alarm	Description
S	Spacing	Sensor spacing may need readjustment.
Z	ZeroMatic	ZeroMatic signal fault.
E	Empty	Pipe is empty.
R	Rate	Flow above High setting or below Low setting.
F	Fault	Three continuous seconds without new data update.
A	Aeration	Current aeration percentage exceeds the alarm set point.
M	Memory	Last valid reading for a selected interval during Fault condition.
K	Makeup	In-Process Makeup occurred.
I	Interface	Liquid Vs exceeds interface alarm set point.

The display shown below indicates where the Alarm Codes appear on the LCD display screen.

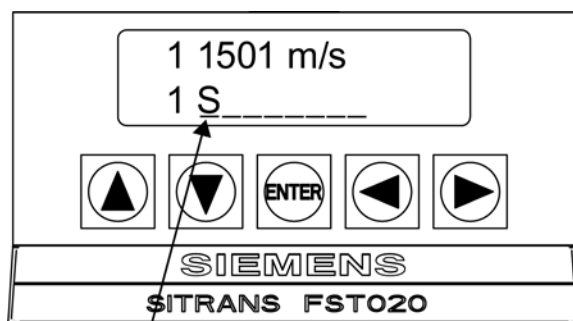

① Alarm Code

8.2 Setting Alarm Levels

The [Set Alarm Levels] menu allows you to select trip-points for system alarm functions. Alarms appear locally on the LCD digital display. In addition, you can use the [Relay Setup] menu to assign those functions to the system's relays. You may select from flow rate, liquid interface (Vs) and liquid aeration alarm functions. Entry of all alarm trip-points is accomplished using the selected rate units. When using RS-232 communication you can enable or disable a Makeup Alarm Latch to keep the makeup alarm active until you reset it manually by an <Fn>6 simultaneous key press on a PC keyboard or by selecting [Yes] or [No] in the [Set Alarms] menu via the keypad.

To access the [Set Alarm Levels] menu:

1. From the [Single Channel] menu, press the <Right Arrow> key.
2. Scroll down to [the Span/Set/Cal] menu and press the <Right Arrow> key.
3. Press the <Down Arrow> key and scroll to [Set Alarm Levels] menu. Press the <Right Arrow> key to access the option list.
 - Hi Flow
 - Low Flow
 - Interface Vs M/S
 - Aeration
 - Makeup Latch

Hi Flow

The [Hi Flow] alarm menu cell allows you to set the HI alarm relay trip-point.

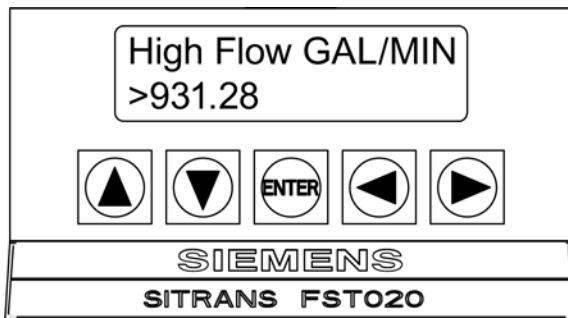

1. Press the <Right Arrow> key to activate numeric entry.
2. Use PC numeric keys or keypad keys to enter the Hi Flow alarm trip-point in the selected flow rate units.
3. To store data press <ENTER>.

Low Flow

The [Low Flow] alarm menu cell allows you to set the Low Flow alarm relay trip-point. To set the Low Flow alarm trip-point:

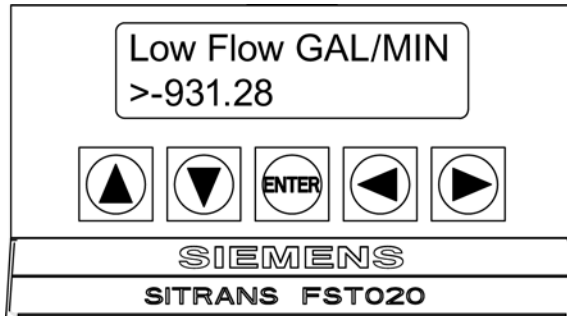

1. Press the <Right Arrow> key to activate numeric entry.
2. Use PC numeric keys or keypad keys to enter the Low Flow alarm trip-point in selected flow rate units.
3. To store data press <ENTER>.

Interface Vs M/S (meters-per-second)

The meter continuously measures liquid sonic velocity (Vs) and tracks changes in this parameter dynamically. It can compare sonic velocity differences in real-time. Its sonic velocity detection is so sensitive that it can quickly distinguish between two different liquids flowing through the same pipe. To set the interface alarm, you select a detection trip-point that falls in the middle of the Vs values of the two liquids.

For example, if Liquid "A" has a sonic velocity of 1249 m/s, and Liquid "B" has a sonic velocity of 767 m/s, 1008 m/s should be entered for the interface trip-point. The Interface Alarm becomes active when the measured Vs meets or exceeds the reference value you enter in this menu cell.

Note

The valid Interface Vs range is: 400 to 2100 m/s.

The [Interface Vs M/S] alarm menu cell allows you to set the Interface alarm relay trip-point.

To enter an Interface Vs alarm trip-point:

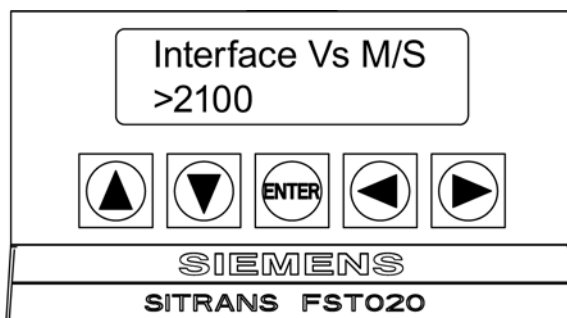

8.2 Setting Alarm Levels

1. Press the <Right Arrow> key to activate numeric entry.
2. Use PC numeric keys or keypad keys to enter the Low Flow alarm trip-point in selected flow rate units.
3. To store data press <ENTER>.

Aeration

The flow meter surpasses all other transit-time systems in its ability to operate with substantial aeration (caused by entrained gases, mixing condition or cavitation). Some applications may require an alarm indication if aeration exceeds a particular level. The meter detects this aeration level and provides this data as an output. The aeration percentage triggers the alarm relay whenever it meets or exceeds the threshold you set in this menu cell.

Note

Severely aerated conditions may induce flow meter fault. The 50% default setting usually allows enough leeway for continued operation. For intermittent faults, see memory interval in the Output Control menu.

The [Aeration] alarm menu cell allows you to set Aeration percentage alarm relay trip-point. To set the Aeration alarm:

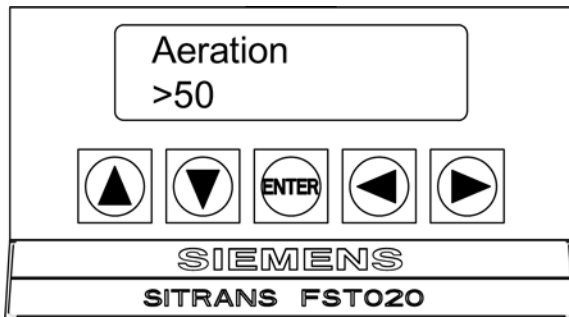

1. Press the <Right Arrow> key to activate numeric entry.
2. Use PC numeric keys or keypad keys to enter the [Aeration] percentage trip-point.
3. To store data press <ENTER>.

Makeup Latch

A fault condition (e.g., caused by an empty pipe or a transient loss of power, etc.) could temporarily interrupt operation. After recovery from the fault, the meter executes an In-Process Makeup to restore operating parameters. During the makeup the meter sets a Makeup Alarm flag that clears upon completion. Therefore, unless you were monitoring the unit continuously, you could miss the fact that an In-process Makeup occurred.

The [Makeup Latch] alerts you that the system implemented a Makeup Alarm by holding the Makeup Alarm active until you reset it manually, via the RS-232 serial connection, by pressing the simultaneous keystrokes: <Fn>6 (where "n" represents the measurement channel). In addition, if the Datalogger is active with Status Alarms selected, generating a Datalogger report will reset the Makeup Alarm Latch. This ensures that the alarm does not appear on succeeding Datalogger reports. A Makeup Alarm appearing on a subsequent report indicates that an In-Process Makeup must have occurred since the last Datalogger report.

The [Makeup Latch] alarm menu cell allows you to set the Makeup Latch alarm relay trip-point To Enable (or Disable) the Makeup Latch:

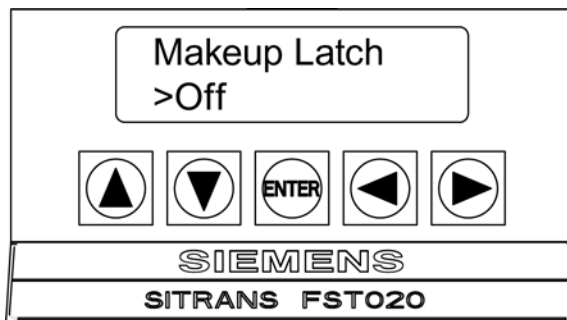

1. Press the <Right Arrow> key to access the [Makeup Latch] option list.
2. Pressing the <Up/Down Arrow> keys to select either [On] or [Off].
3. Press <ENTER> to turn the Makeup Latch [On] or [Off].

Maintenance and Service

9.1 Maintenance

 WARNING
Hazardous Voltage
May cause death or serious personal injury. Disconnect power before working on this product.

The device is maintenance-free, however; a periodic inspection according pertinent directives and regulations must be carried out.

An inspection can include the checking of:

- Ambient conditions
- Seal integrity of the process connections, cable entries, and cover screws
- Reliability of power supply, lightning protection, and grounds

9.2 Technical support

NOTICE
Repair and Service
Repair and service must be carried out by approved Siemens personnel only.

Note

Siemens defines sensors as non-repairable products.

Technical Support

If you have any technical questions about the device described in these Operating Instructions and do not find the right answers, you can contact Technical Support:

- Via the Internet using the **Support Request**:
Service and support (<http://www.siemens.com/automation/service&support>)
- Phone: +49 (0) 911 895 7222 / 1 800 333-7421

Further information (Page 8) about our technical support is available in the Internet at Technical support (<http://support.automation.siemens.com/WW/view/en/16604318>)

Service & Support on the Internet

In addition to our documentation, we offer a comprehensive knowledge base online on the Internet at:

Support request (<http://www.siemens.com/automation/support-request>)

There you will find:

- The latest product information, FAQs, downloads, tips and tricks.
- Our newsletter, providing you with the latest information about your products.
- A Knowledge Manager to find the right documents for you.
- Our bulletin board, where users and specialists share their knowledge worldwide.
- You can find your local contact partner for Industry Automation and Drives Technologies in our partner database.
- Information about field service, repairs, spare parts and lots more under "Services."

Additional Support

Please contact your local Siemens representative and offices if you have additional questions about the device

Find your contact partner at:

Local contact person (<http://www.automation.siemens.com/partner>)

9.3 Return procedures

Enclose the delivery note, the cover note for return delivery and the declaration of decontamination form on the outside of the package in a well-fastened clear document pouch.

Required forms

- **Delivery Note**
 - **Cover Note for Return Delivery** with the following information
 - Cover note (<http://support.automation.siemens.com/WW/view/en/16604370>)
 - product (ordering number)
 - number of devices or spare parts returned
 - reason for the return
 - **Declaration of Decontamination**
 - Declaration of Decontamination (http://pia.khe.siemens.com/efiles/feldg/files/Service/declaration_of_decontamination_en.pdf)
 - With this declaration you certify *that the returned products/spare parts have been carefully cleaned and are free from any residues.*
 - If the device has been operated together with toxic, caustic, flammable or water-damaging products, clean the device before return by rinsing or neutralizing. Ensure that all cavities are free from dangerous substances. Then, double-check the device to ensure the cleaning is completed.
 - We shall not service a device or spare part unless the declaration of decontamination confirms proper decontamination of the device or spare part. Shipments without a declaration of decontamination shall be cleaned professionally at your expense before further proceeding.
- You can find the forms on the Internet and on the CD delivered with the device.

Troubleshooting

10.1 Troubleshooting

The following is list of troubleshooting tips and messages that you may encounter. They include explanations and, in some cases, a recommended action. If a problem seems unsolvable, contact your local Siemens office or regional Ultrasonic Flow Representative for expert help at Partner (<http://www.automation.siemens.com/partner>).

Table 10- 1 Troubleshooting Tips

Error or Message	Probable Cause	Solution
Memory Full!	Response to an attempt to save site data, when data memory is full.	Delete an obsolete site or clear Datalogger memory to make room for the new data.
Memory Corrupted!	Memory read error occurred while accessing the active site data.	Refer to F4 reset procedure in the Operation Instructions manual.
Chan Not Setup	Response to an attempt to invoke an operation that requires a channel to be enabled.	Enable the channel [Channel Setup - Channel Enable - Yes]. Note that a channel cannot be enabled until an "Install" operation is completed.
Clr Active Memory?	Response to pressing and holding <ENTER> key during power-up.	Use this function to restore operation if a severe event (e.g. a violent power surge) disrupts the system operation.
Clr Saved Data?	[Clr Saved Data?] only appears after pressing the <Down Arrow> in response to [Clr Active Memory?].	Answering Yes to [Clr Saved Data?] will erase ALL saved data. To invoke in RS-232 serial mode, type @@@ and then press <ENTER> key.
<EOT>	Response to a request to output Datalogger data to the printer or the Graphics screen when no Datalogger data exists or at the end of a transmitted file..	Set up the Datalogger.
No Sites - Press <ENTER>	Response while trying to recall/delete a site setup when no sites are stored.	Create a site.
Security	Response upon changing previously entered data when security switch is in [Disable] position or security code has been entered.	<ul style="list-style-type: none"> Change switch position to [Enable]. Enter previously set security code.
RTC Error	Component level problem.	<ul style="list-style-type: none"> Meter requires service. Request RMA.
- - -F- - - Fault Alarm	<ul style="list-style-type: none"> Loss of signal strength (ALC) Change of Rx signal location (Beam Blowing) 	<ul style="list-style-type: none"> Recouple sensors with fresh couplant. Install sensors in Direct mount mode. Note: If problem persists call Tech support.
Re-space #	The measured liquid sonic velocity (Vs) is more than +/- 25% of the average Vs range.	<ul style="list-style-type: none"> Assure proper pipe dimensions and/or Liquid data entries are correct. Properly enter correct Sensor Size into the meter [Install Sensor] menu. Confirm sensor spacing is correct by checking [Install Sensor] menu spacing parameters.

Error or Message	Probable Cause	Solution
Invalid Setup (use Direct Mode)	<ul style="list-style-type: none"> During the Initial Makeup the system detects invalid sensor spacing, erroneous liquid pipe parameters, or some other factor that prevents it from completing the Initial Makeup. 	<p>This may be due to one of the following:</p> <ul style="list-style-type: none"> An out-of-range data entry. An invalid condition (e.g., overlapping sensors in Reflect Mode). If selecting Direct Mode does not resolve, review all site setup and sensor installation choices particularly data entered for pipe and liquid. In Reflect Mode the flow meter detects that the pipe wall signal may infringe upon the liquid signal. Use Direct Mode instead. <p>Press <ENTER>, <Up Arrow>, <Down Arrow>, or <Left Arrow> to abort install routine. Continue programming other site data in anticipation of resolving the difficulty later. Call technical support for help if necessary</p>
Low Signal - Press <ENTER>	<p>During the Initial Makeup the flow meter decides that the level of the receive signal is insufficient for proper operation.</p>	<p>Some reasons for low signal are:</p> <ul style="list-style-type: none"> Invoking [Install completed?] on an empty pipe. Coupling compound insufficient; not applied or evaporated. A disconnected or broken sensor cable. The pipe needs to be conditioned at the mounting location. Flush out large air bubbles. The sensor cables are defective or not connected to the correct channel. The Set Empty routine performed when pipe was NOT actually empty. <p>If you locate and correct the improper condition immediately, press <ENTER> to resume the installation procedure. Otherwise, press the <Left Arrow> to abort the installation and conduct a thorough investigation.</p>
Detection Fault	<p>If it appears that the flow meter cannot complete an Initial Makeup it means that the pipe and/or liquid conditions do not permit a receive signal that meets the flow detection standards. The system will not operate.</p>	<p>Attempt to improve operating conditions by reinstalling the sensors at a different spacing offset, or even at a different location on the pipe. Switching from Reflect to Direct Mount may solve the problem. However, operation may not be possible if there is poor liquid or pipe wall sonic conductivity.</p>

Note

If you receive a Detection Fault message, it is strongly recommended that the Services & Support (<http://www.siemens.com/automation/service&support>) be contacted.

10.2 Force Transmit

NOTICE
Force Transmit and Force Frequency diagnostic procedures
The Force Transmit and Force Frequency diagnostic procedures are preconfigured at the factory and should only be implemented by approved Siemens personnel.

This diagnostic software routine allows the user to "force" a transmitting condition that can be used to search for an amplitude level (ALC) when Detection Fault or Low Signal alarms are present. The routine forces the flow meter to generate constant transmit bursts while reporting current receive signal strength for the user. To initiate the Force Transmit function, refer to the Short Burst detection mode example shown below.

Note

The typical screens below are shown only when using a PC via the RS-232 port.

Setting a Force Transmit condition (via RS-232 serial port)

1. After [Install] command is invoked press the <ENTER> key.
2. As the meter goes through the drives press [ENTER] again.

Siemens	Dual Path [1]	ABC	Siemens	Dual Path [1]	ABC
Install Completed?			Drive 0		
Install Path	1		Install Path	1	
Sensor Model	1011HP-T1		Sensor Model	1011HP-T1	
Sensor Size	B3		Sensor Size	B3	
Sensor Mount Mode	Direct		Sensor Mount Mode	Direct	
Spacing Offset	Minimum		Spacing Offset	Minimum	
Number Index	4		Number Index	4	
Spacing Method	Spacer Bar 1012TP		Spacing Method	Spacer Bar 1012TP	
Ltn Value (in)	0.217		Ltn Value (in)	0.217	
Install Complete	No		Install Complete	Install	
Empty Pipe Set	Channel Not Setup		Empty Pipe Set	Channel Not Setup	
Zero Flow Adjust	Channel Not Setup		Zero Flow Adjust	Channel Not Setup	
Install Sensor			Install Sensor		

3. A typical menu screen will appear as shown below and indicate the current ALC (e.g., 50). This ALC number indicates the current receive signal strength and can be used for further diagnostic purposes.

Note

When using a PC the <ALT> and <Enter> keys must be pressed before the flow meter scans through all the drives, or the Force Transmit function must be initiated again.

Note

The FST020 flow meter does not display the Force Transmit data display line.

Siemens	Dual Path [1]	ABC	Siemens	Dual Path [1]	ABC
ForceN	fx=8	m=7	ALC=50		
Install Path	1		Install Path	1	
Sensor Model	1011HP-T1		Sensor Model	1011HP-T1	
Sensor Size	B3		Sensor Size	B3	
Sensor Mount Mode	Direct		Sensor Mount Mode	Direct	
Spacing Offset	Minimum		Spacing Offset	Detection Fault	
Number Index	4		Number Index	Press [ENT]	
Spacing Method	Spacer Bar 1012TP		Spacing Method		2TP
Ltn Value (in)	0.217		Ltn Value (in)	0.217	
Install Complete	Install		Install Complete	Install	
Empty Pipe Set	Channel Not Setup		Empty Pipe Set	Channel Not Setup	
Zero Flow Adjust	Channel Not Setup		Zero Flow Adjust	Channel Not Setup	
Install Sensor			Install Sensor		

4. To exit Force Transmit, press the <Left Arrow> key and a Detection Fault prompt will appear (see above).
5. Press the <Left Arrow> key again and the meter will return to the [Install Sensor] menu and highlight the [Empty Pipe Set] menu cell.

Setting a Forced Frequency

1. To force a frequency, repeat steps 1, 2 and 3 above, but press the <Right Arrow> key. The following typical display line will appear: **=Drive=0**
2. Using PC keys to enter the frequency and press <ENTER> key.
3. To complete the Install process after mounting the sensors, press <ENTER> key.
4. If the Force Transmit diagnostic procedure is not used, the normal [Install Complete] function occurs.

10.3 System Reset

Should an operating problem that blocks access to the Installation Menu occur, or the meter operates erratically after exposure to a power transient or some other traumatic event, this might require the use of the reset sequence in order to restore proper operation. System FST020 provides two system resets.

The first uses the Keypad and the second method uses a PC command sent via the RS-232 interface (providing you have access to the flow meter in this way).

The reset sequence operates on two levels.

- The first level deletes all the data currently in Active Memory, but leaves Datalogger data and all stored Site Setups intact. This is the most desirable method since to restore operation all you have to do is reload a saved Site Setup.
- If this fails then you have to use the second level, which clears ALL Saved Memory. Be aware that this action erases all saved Site Setups (including flow calibrated sites), any logged data and any user-defined pipe and sensor tables. This will require you to re-initialize the flow meter and sensors and repeat all desired site settings, custom pipe tables, etc.

Keypad System Reset

There is a power-on delay of a few seconds from the time power is applied to the flow meter to when the 16 x 2 Character LCD becomes active. The reason for the delay is to allow the following system reset procedure to be performed.

Clearing Active Memory

To clear Active Memory using the Keypad:

1. Turn off power (if it is currently on) and then reapply power to the system.
2. Press and hold the < ENTER > key during the power-on delay. Examine the first figure below and note the [Clr Active Mem?] message on the LCD display.

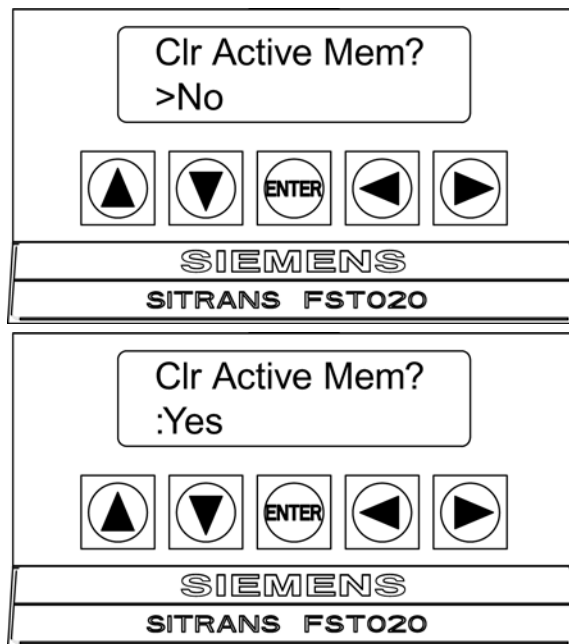

3. Press the <Right Arrow> key. Note that the greater than (>) symbol changes to a (:). Press the <Down Arrow> key to change the second line to [Yes] as shown in the figure above.
4. Press the <ENTER> key to clear the contents of Active Memory (but preserve any stored Site Setups).
5. To restore operation, create a new site setup or recall a stored site setup and then re-select any Meter Facilities items (e.g., RS-232 setup parameters) that you may have edited originally.

Clearing All Saved Memory

To clear ALL Saved Memory using the Keypad:

 CAUTION
Loss of RAM Data
Before proceeding further it is essential to understand that this function eliminates ALL data stored in RAM. This means that all saved Site Setups including the site data of a flow-calibrated site will be erased! In addition, the entire Datalogger file plus any custom factory or user-created pipe or sensor tables will be eliminated. The impact of this is such that we strongly recommend that you consult the Technical Service Department (Page 107) before continuing with this procedure. If you choose to continue, be aware that you will have to create a new Site Setup, re-enter all site specific parameters including pipe or sensor tables, plus all desired Meter Facilities entries.

1. Turn off power (if it is currently on) and then reapply power to the system.
2. Press and hold the < ENTER> key during the power-on delay. Examine the first figure below and note the [Clr Active Mem?] message on the LCD display.

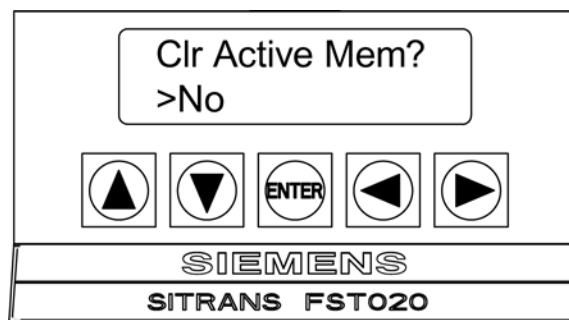

- Press <Right Arrow> key twice. The display switches to [Clr Saved Data? No] as shown in the figure below.

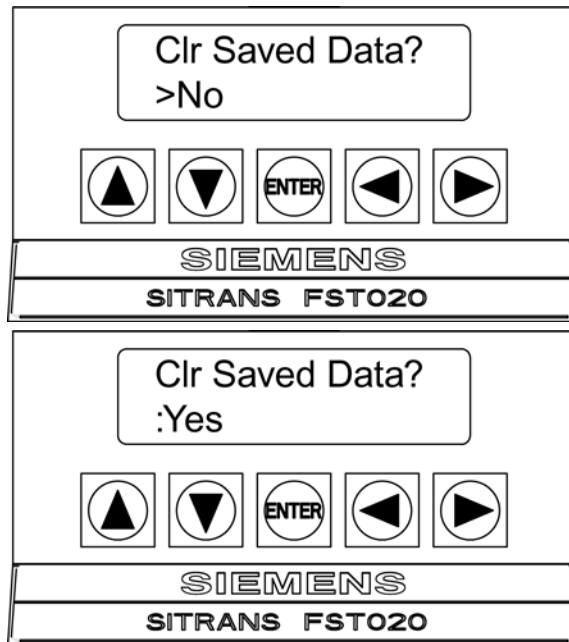

- Press <Right Arrow> key. Note that the greater than (>) symbol changes to a (:): colon. Press the <Down Arrow> key to change the second line to [Yes] (as shown in the figure above). Press the <ENTER> key to clear All Saved Memory.
- To restore operation, create a new Site Setup and then re-select any Meter Facilities items (e.g., RS-232 setup parameters) that you may have edited originally.

RS-232 Interface System Reset

The FST020 flow meter also allows you to perform a system reset via its RS-232 interface. The following instructions require the flow meter to be connected serially to a PC. Refer to RS-232 Connection (Page 21) for details on how to set up an RS-232 interface with a PC.

Clearing Active Memory

To clear Active Memory using the RS-232 Interface:

- Turn off power (if it is currently on). Turn power on. As soon as you apply power type the @ character three times. The prompt: [Clr Active Memory? No] appears at the top of the screen.
- Press the <Right Arrow> and then the <Down Arrow> key to switch the option list to [Clr Active Memory? Yes]. Press <ENTER> to clear all Active Site Data (but not saved Site Setups).
- To restore operation, type: MENU and press <ENTER> to access the Installation Menu. Create a new Site Setup or recall a stored Site Setup. Re-select any Meter Facilities items (e.g. RS-232 setup parameters).

Clearing All Saved Memory

To clear All Saved Memory using the RS-232 Interface:

1. Turn off power (if it is currently on).
2. Turn power on. As soon as you apply power type the @ character three times. The prompt: [Clr Saved Data? No] appears at the top of the screen. Press the <Down Arrow> key. Note that the prompt switches to [Clr Saved Data? No].
3. Press the <Right Arrow> and then the <Down Arrow> key to switch the option list to [Clr Saved Data? Yes]. Press <ENTER> to clear All Saved Memory.
4. To restore operation, type: MENU and press <ENTER> to access the Installation Menu. Create a new site setup and complete the installation procedure. Re-select desired Meter Facilities items (e.g., RS-232 setup parameters).

See also

Services & Support (<http://www.siemens.com/automation/service&support>)

10.4 Site Setup Data

This menu provides data pertaining to sensor characteristics and operation. Some menu items are for technical support interpretation only.

Table 10- 2 Site Setup Menu Items

fx Drive	Current Transmit drive code selected during Initial Makeup. The drive code controls the sonic transmit signal.
N (burst length)	Transmit burst duration selected during Initial Makeup. To change N count press <Right Arrow>. At equal sign enter numeric value (1 to 9 only).
Ltn (mm/in)	Spacing distance between the sensors. It will be in inches or millimeters, depending on default units.
Vf max	The flow velocity (in selected units) corresponding to one whole cycle offset between upstream and downstream receive signals.
Vs max M/S	Maximum Vs for current sensor spacing.
Vs min M/S	Minimum Vs for current sensor spacing.
Empty	Value of Empty Alarm Setting. The meter will declare an empty status if signal strength drops below this value.
Samples/Cycle	Digital sampling rate.
Max Damping	Maximum signal damping. Use to average digital data when an unstable condition occurs.
Min Damping	Minimum signal damping. Use to average digital data when an unstable condition occurs.
HF	Flow registration correction parameter.

[HF] Menu Item

The flow meter includes a Diagnostics Menu item that permits the entry of a flow registration correction parameter labeled [HF]. This "HF" parameter is the input for a proprietary algorithm that automatically compensates for signal beam blowing, thereby extending the upper flow limit of the flow meter. The HF parameter should only be adjusted in cases where the user suspects that extreme flow velocity or a large delta-time may be causing signal correlation problems.

Using the [HF] Menu Cell

Two methods for adjusting this parameter are provided via the [HF] menu cell, located within the [Diagnostics] / [Site Setup] submenu. The "Manual" method provides direct entry of this parameter and is primarily intended for the advanced user, whereas the "Automatic" method allows the flow meter to automatically measure the required correction and install the parameter.

Guidelines for use

- This menu is only accessible for the sensor channel.
- The flow meter will inhibit the "Automatic" installation of the [HF] parameter if the flow rate is insufficient (too low) to accurately measure the required correction. If the maximum flow rate for the application is relatively low then this correction is not be required.
- If the flow rate is very high and the flow meter is reporting erroneous or unstable flow, then the flow meter may already be having trouble resolving the upstream and downstream signals. In this event, it may be necessary to first lower the flow rate to a moderate level before performing the "Automatic" HF adjustment. Once this is done the flow meter should be able to properly measure the highest flow rates without problems.
- The limits of the "HF" parameter are +/- 0.7 and any attempt to manually install a larger value will cause the flow meter to abort the installation of the parameter.

Note

Pressing the <Left Arrow> key at any stage prior to accepting the measured value will abort the installation and return to the previous setting.

Accessing the [HF] Function

1. At the [Meter Type] Menu, press the <Right Arrow> and then <ENTER>.
2. Press the <Down Arrow> key and scroll to the [Diagnostic Data] menu cell. Press the <Right Arrow> key.
3. Press the <Down Arrow> key and scroll to the [Site Setup Data] menu cell.

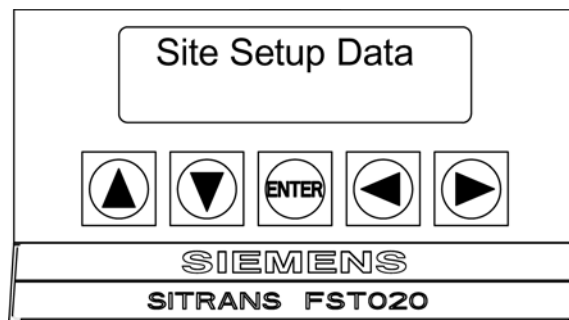

4. Press the <Right Arrow> key to select the option list.

Manual Adjustment Procedure

1. At the [Site Setup Data] Menu, press the <Right Arrow> key and scroll to the [HF] menu cell. Press the <Right Arrow> key and [Manual] will appear in the display.

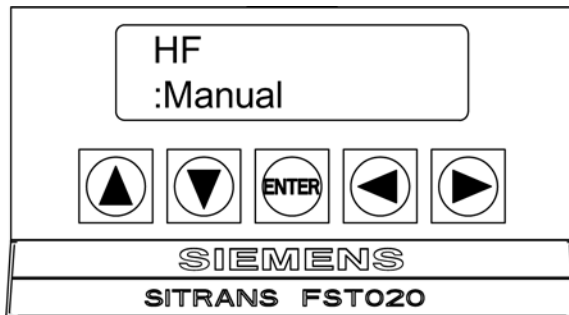

2. Press the <Right Arrow> key and use the keypad keys to input the desired correction value. Press <ENTER> to input value.

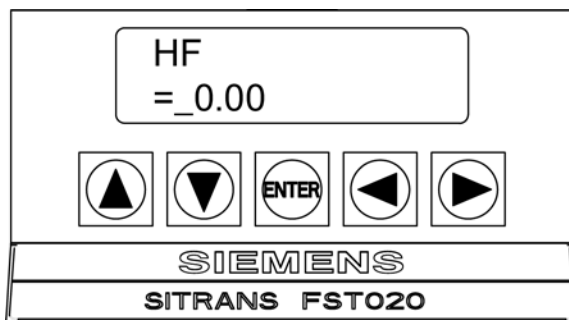

3. The new correction value will appear in the [HF] menu cell as shown below.

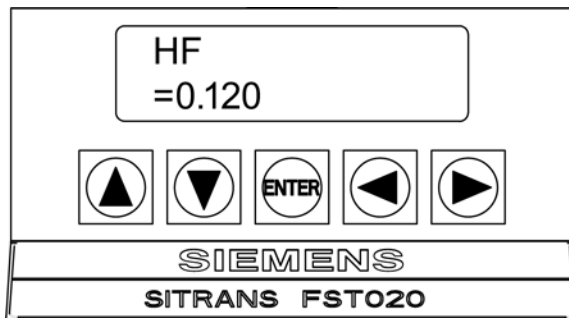

Automatic Adjustment Procedure

1. At the [Site Setup Data] Menu, press the <<Right Arrow> key and scroll to the [HF] menu cell.
2. Press the <Right Arrow> key and [Manual] will appear.
3. Press the <Up or Down Arrow> keys to select [Automatic] then press <ENTER>.

- The current measured correction value is displayed.

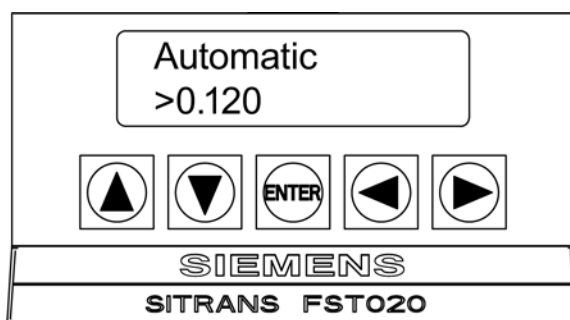

- Press <ENTER> again to install this correction value that will now appear in the [HF] menu cell.

Note

The value shown in the [Automatic] display line can not be changed and is for user information only.

- If you decide not to use the [Automatic] selection, press any key other than <ENTER> to abort the operation.

Technical data

Input

- Flow Range: ± 12 m/s (± 40 ft/s) bi-directional
- Flow Sensitivity: 0.0003 m/s (0.001 ft/s) flow rate independent

Digital Inputs

- Totalizer Hold Optically isolated diode
Input voltage: 2-10 VDC
- Totalizer Reset Optically isolated diode
Input voltage: 2-10 VDC

Output

- Current 4-20mA (Isolated)
externally powered 10-30 VDC
- Relay Programmable Form C
250mA, 30 VDC, 3 VA max
- Pulse Rate Optically isolated transistor
10mA, 30 VDC, max

Accuracy

- Flow, 0.5 - 1.0% for velocities ≥ 0.3 m/s (1 ft/s)
- 4...20mA $\pm 1.0\%$ - 2.0% of span for assigned parameters
- Pulse, relay output $\pm 0.5\%$ - 1.0% of flow
- Batch repeatability: $\pm 0.15\%$
- Zero Drift: 0.1% of rate: 0.0003 m/s (0.001 ft/s)
- Data refresh rate: 5 Hz

Transmitter Operating Conditions

- Operating Temperature: -10 to 50°C (14°F to 122°F)
- Storage Temperature: -20°C to 60°C (-4°F to 140°F)
- Degree of Protection: IP65/Type 4X/NEMA 4X

Design

- Weight 1.4 kg (3 lbs)
- Dimensions (WxHxD) 175.7 mm x 240.3 mm x 91.1 mm (6.92 in x 9.46 in x 3.59 in)
- Enclosure Material: Polycarbonate

Power Supply

- AC Version 100 - 240 VAC, 50/60 Hz, 20 VA max.
- DC Version 11.5 - 28.5 VDC, 10 watts max.

Certifications and approvals

Unclassified locations only UL Listing
ULc Listing

CE:

- EMC EN 61000-6-2,-4
C-TICK

Appendix

A.1 Certificates

All certificates are posted on the Internet. Additionally, the CE Declaration of Conformity as well as UL listings approvals are available on the Sitrans F literature CD-ROM Certificates (<http://www.siemens.com/processinstrumentation/certificates>)

A.2 Ordering

In order to ensure that the ordering data you are using is not outdated, the latest ordering data is always available on the Internet: Catalog process instrumentation (<http://www.siemens.com/processinstrumentation/catalogs>)

See also

Process instrumentation catalog (<http://www.siemens.com/processinstrumentation/catalogs>)

A.3 I/O Connections and Wiring

Terminal Block Wiring - FST020 Flow Meter

These connection diagrams apply to the part numbers listed below.

Table A- 1 Part Numbers and Connection Diagrams

SITRANS FST020	
FST020	7ME3570-*****

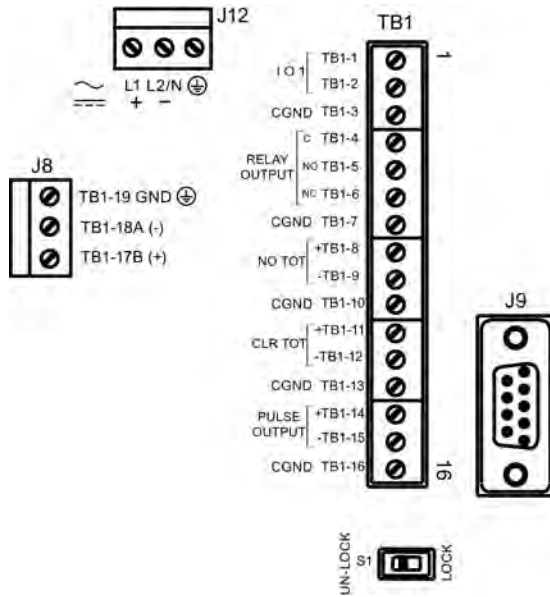

Figure A-1 Terminal TB1 including J8 Connector, DB9 Connector (J9), Power Connector (J12) and Menu Lockout Switch (S1)

Table A-2 J8 Connector

Pin#	Signal	Function	Description
TB1-19	GND	GND	Reference Ground
TB1-18	A (-)	RS-485	RS-485 Serial Communications Port
TB1-17	B (+)	RS-485	RS-485 Serial Communications Port

Table A-3 J9 Connector (DB9)

Pin #	Signal
1	N/C
2	RxD
3	TxD
4	DTR
5	Ground
6	N/C
7	RTS
8	CTS
9	N/C

Table A- 4 Input/Output Wiring (TB1)

Pin#	Signal	Function	Description
1	Io1+	Isolated Loop Supply	Spannable 4-20mA output (Loop Powered) This output also provides a fault indication by dropping to 2mA if assigned to flow rate and under fault conditions.
2	Io1-	Isolated Loop Return	
3	GND	Ground	Ground
4	C	Closed	Relay Output
5	NO	Normally Open	Relay Output
6	NC	Normally Closed	Relay Output
7	GND	Ground	Ground
8	NO TOT +	DIGITAL INPUT +	Stops Totalizer from incrementing.
9	NO TOT -	DIGITAL INPUT -	
10	GND	Ground	Ground
11	CLR TOT +	DIGITAL INPUT +	Clears Totalizer
12	CLR TOT -	DIGITAL INPUT -	
13	GND	Ground	Ground
14	PULSE OUTPUT +	Isolated Transistor	Menu selection: PGEN, POS TOTAL, NEG TOTAL
15	PULSE OUTPUT -	Isolated Transistor	
16	GND	Ground	Ground

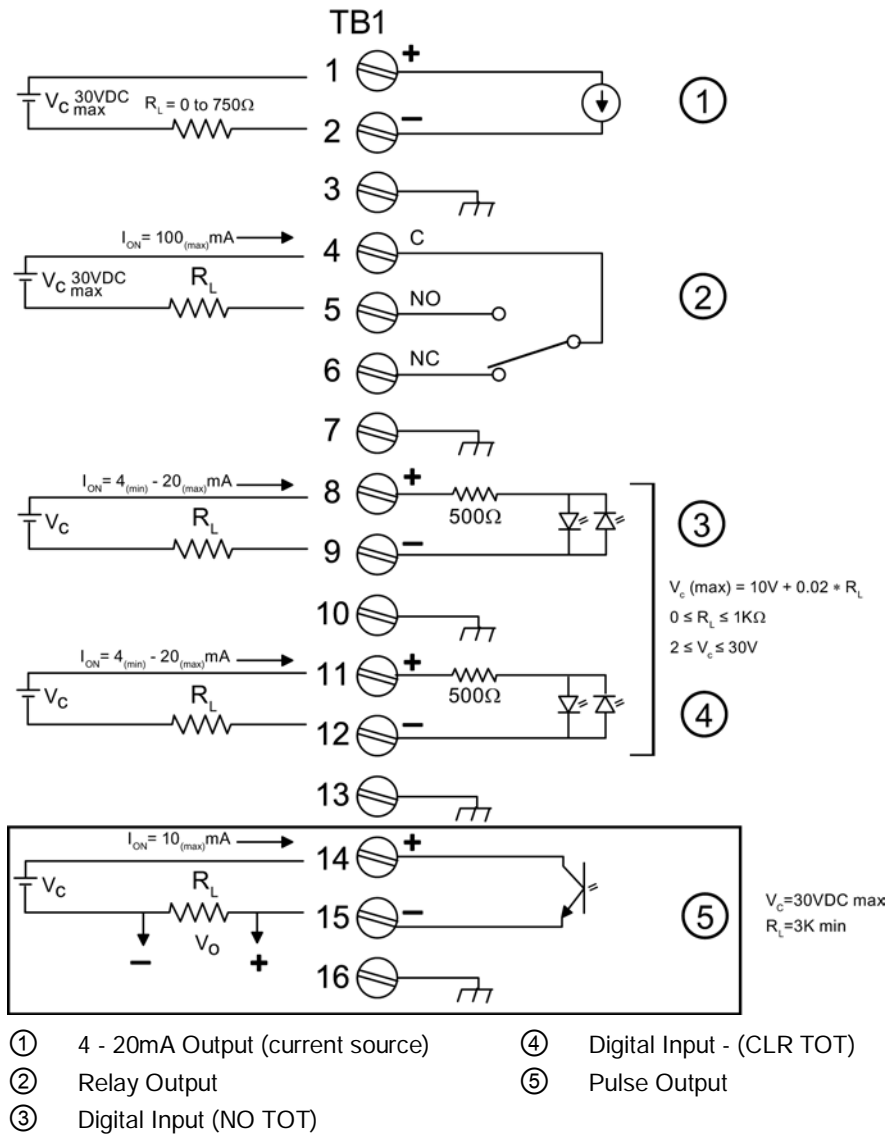

Figure A-2 Typical TB1 Wiring

Isolated 4-20mA Output TB1-1/2	
R	= 250 Ω typical, 750 Ω maximum
V _c	= 24 VDC typical / 30 VDC maximum
I	= 4-20mA
R _L	= Loop wire resistance (both ways) plus User's input load resistance.

PULSE OUTPUT TB1-14 / TB1-15	
V _c	= +30 VDC max.
R _L	= 3K Ω minimum

Relay TB1-4 / TB1-5 / TB1-6	
R_L	= 300 Ω minimum

Digital Inputs TB1-8 / TB1-9 and TB1-11 / TB1-12	
V_c	= (10V + 0.02 x R_L) max. $2 \leq V_c \leq 30$ VDC
$0 \leq R_L \leq 1000 \Omega$	

A.4 Flowrate Calibration

Flowrate Calibration Methods

The flow meter [Calib. Flowrate] menu option in the [Span/Set/Cal] menu provides three ways to condition the calibration performance of its flowrate output:

- Intrinsic (factory set)
- Kc (Slope Correction)
- MultiPoint (Non-Linear)

Intrinsic

When selected, the flow meter uses no slope adjustment at all. Output data is still zeroed and corrected for Reynolds number, but no slope adjustment is imposed on the flow meter's flow register.

Note

You can select Intrinsic (factory) and/or Kc (Slope Correction) calibration using the [Calib. Flowrate] menu cell. Selecting either of these external calibration modes will not eliminate the Intrinsic (factory) calibration. The [Calib. Flowrate] menu cell can be switched between Intrinsic and Kc at any time.

Kc Calibration

For most applications, the measured flow range produces a linear meter response. Therefore, the Kc (slope correction) calibration is the preferred method since it only requires a single correction factor for all the flow rates encountered.

Note

Changing the calibration can cause profound changes in flow meter operating characteristics. Use only the most respected flow standard to obtain a correction factor. The percentage entered must provide an accurate and consistent shift across the entire flow range anticipated for the application.

Kc Factor

To obtain the Kc factor, compare flow total data taken simultaneously from the flow meter and a reference meter whose accuracy meets the required standard. Allow both meters to accumulate flow total data long enough to average out any differences due to flow fluctuation between the two meter locations. Compare outputs of the two totalizers to determine percentage increase (+) or decrease (-) that is necessary to produce the best average correlation between the flow meter and the reference standard.

Selecting the Kc Factor

When the [Kc] menu cell is selected, the flow meter imposes this percentage slope adjustment of its rate output. Output data is zeroed and corrected for the Reynolds number (flow profile compensated); however, a percent change in the rate output is imposed based on the data entered in this cell. The number entered by the user is evaluated into a slope correction factor by dividing it by 100 and algebraically adding it to 1. The resulting factor is used as a multiplier on the rate register of the instrument. Thus an entry of -3% will multiply the rate register by 0.97, for example.

To calculate Kc:

$$Kc = \left(\frac{\text{Indicated Rate}}{\text{Reference Rate}} \right) \times 100$$

To enter the Kc Factor

1. From the [Meter Type] menu press the <Right Arrow> key and then <ENTER>.
2. Scroll down to the [Span/Set/Cal] menu, press the <Right Arrow> key and scroll down to [Calib. Flowrate].
3. To enable the Kc Factor press the <Right Arrow> key.

4. Press the <Right Arrow> again and use the keypad keys to enter the required Kc factor (as calculated above). Note that the Kc value can be negative or positive. Enter the - or + sign first and then enter the calibrated value.
5. To store the data press <ENTER>. Note that Kc now appears in the [Calib. Flowrate] menu cell with its new value. Also note that this Kc value can be viewed on the site printout.

MultiPoint Calibration

MultiPoint calibration serves applications that require a non-linear meter calibration. You can enter correction factors for up to ten significant points over the entire measurement range. This is accomplished by:

- Selecting up to 10 separate calibration points by entering a raw (un-calibrated) flow rate.
- Entering a negative or positive correction for each calibration point that you select.

Like the Kc slope correction described previously, you locate critical flow rate points by comparing flow total data taken simultaneously from the flow meter and a reference meter whose accuracy meets the required standard. Again, it is important to note that you must allow both meters to accumulate flow total data for long enough to average out any differences due to flow fluctuation between the meter locations.

Compare the two flow total readings to identify up to ten separate points (termed raw flow rates) where there are significant deviations between flow meter and the reference meter. Calculate correction factors (either negative or positive percentages) for up to ten points along the flow range. For example, entering [-0.1] for point 1 produces a negative 0.1% change in the meter output whenever the system measures the raw flow rate specified for point 1, etc. The valid range for each percent correction is from -50% to +50%. If you enter a value outside of this range, the flow meter will set the calibration factor to the nearest limit.

Use these to match the output of the flow meter with the response curve of the reference meter. Selected calibration points must increase in magnitude from point 1 to point 10 (or the last point that you want to calibrate).

Note

Raw flow rates must be entered in ascending order.

To perform a MultiPoint calibration:

1. From the [Meter Type] menu press the <Right Arrow> key and then <ENTER>.
2. Scroll down to the [Span/Set/Cal] menu, press the <Right Arrow> key and scroll down to [Calib. Flowrate].
3. Press the <Right Arrow> key and scroll to [Multipoint].

- 4. Press the <Right Arrow> key and then <ENTER>. This allows the following MultiPoint calibration selections:

Point #	Point 1 selected
Indicated Rate	Shows current rate for point #1
% correction	The amount of correction applied either (-) or (+) percentages

- 5. Press the <Down Arrow> key to move to the [Indicated Rate] field and then press the <Right Arrow>key to enable numeric entry.
- 6. Use PC numeric keys or keypad keys to enter a flow rate for point #1, then press <ENTER>. The [% Correction] field for point #1 will appear.
- 7. Press the <Right Arrow> key to enable numeric entry.
- 8. Use PC numeric keys or keypad to enter the required % correction for point #1.
- 9. Press <ENTER>. The [Point #] field returns.
- 10.To enable numeric entry press <Right Arrow> key and then enter [2] (for the second calibration point).The cursor moves to the point #2, which is the [Indicated Rate] field.
- 11.Use PC numeric keys or keypad keys to enter a flow rate for point #2. The value entered here must be of a greater magnitude than the value entered for point #1.
- 12.Press <ENTER>. The cursor moves to the [% Correction] field.
- 13.To enable numeric entry press <ENTER>.
- 14.Use PC numeric keys or keypad keys to enter the required % correction for point #2. Press <ENTER>.
- 15.Repeat this procedure for all required calibration points. After entering the last Flow Calibration Point press the <Right Arrow> to exit MultiPoint Calibration.

A.5 BACnet/ModBus Communications

A.5.1 Introduction

Introduction

The Siemens SITRANS FST020 Flow Meter firmware version 2.04.06 and later includes ModBus and BACnet communication selectable during the configuration of the meter.

Note**IMPORTANT**

To invoke BACnet or ModBus communications, RS-485 setup parameters must be enabled.

A.5.2 BACnet

BACnet Communication Protocol

BACnet is a standard communication protocol for **B**uilding **A**utomation and **C**ontrol **N**etworks developed by the American Society of Heating, Refrigerating and Air-Conditioning Engineers (ASHRAE). BACnet provides the communication infrastructure needed to integrate products made by different vendors. BACnet communication is based on standard objects. Each BACnet Device includes a Device Object and other optional objects within the device. Each object has associated properties. This document defines the FST020 BACnet objects and its properties. The FST020 includes (1) Device Object, (29) Analog Value Objects, and (11) Binary Value Objects.

The FST020 functions as a BACnet slave device on a BACnet MSTP RS485 network. A typical illustration of how this might be configured in a plant network is illustrated in the figure below.

Note**IMPORTANT**

The BACnet proxy router is not included and must be supplied by the user.

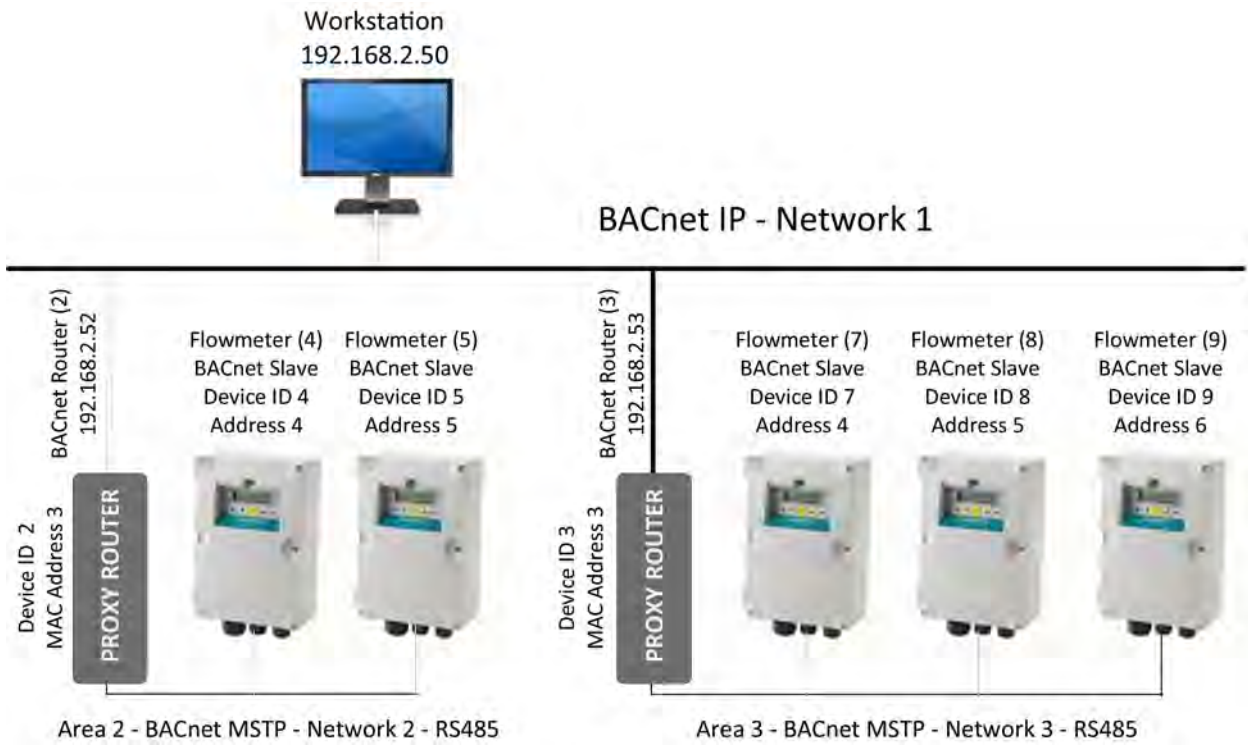

Figure A-3 Typical FST020 BACnet Application

Device Object

Property Identifier	Description and/or Example Value	R/W
Object_Identifier	BACnetObjectIdentifier	W
Object_Name	<i>Entered during FST020 Configuration</i> (15 characters)	W
Object_Type	DEVICE (8)	R
System_Status	OPERATIONAL (0)	R
Vendor_Name	Siemens Industry, Inc.	R
Vendor_Identifier	313	R
Model_Name	FST020	R
Firmware_Revision	2.04.06 (or later)	R
Application_Software_Version	012813-1338	R
Protocol_Version	1	R
Protocol_Revision	10	R
Protocol_Services_Supported	read property, read property multiple , write property	R
Protocol_Object_Types_Supported	Device , Analog Value, Binary Value	R
Object_List	Dx, AV0...AV28, BV0...BV10	R
Max_APDU_Length_Accepted	480	R
Segmentation_Supported	3 – no segmentation	R
Local_Time	10:36:13	R
Local_Date	1/21/2013	R
APDU_Timeout	0	R
Number_Of_ADPU_Retries	0	R
Device_Address_Binding	0	R
Database_Revision	2	R

Analog Value Object

Property Identifier	Description and/or Example Value	R/W
Object_Identifier	Unique Identifier (e.g. 8388608)	R
Object_Name	<i>(see Analog Value Object List)</i> (e.g. Flow)	R
Object_Type	2 – Analog Value	R
Present_Value	REAL (e.g. 402.3467)	R
Description	Character String (e.g. GAL/MIN)	R
Status_Flags	IN_ALARM,FAULT,OVERRIDDEN,OUT_OF_SERVICE (e.g. 0000)	R
Event_State	0 - Normal	R
Out_Of_Service	0 - False	R

Binary Value Object

Property Identifier	Description and/or Example Value	R/W
Object_Identifier	Unique Identifier (e.g. 20971525)	R
Object_Name	(see list of Binary Value objects (e.g. Aeration Alarm	R
Object_Type	5 – Binary Value	R
Present_Value	Binary (e.g. 1)	R
Description	Character String (e.g. Aeration Alarm)	R
Status_Flags	IN_ALARM,FAULT,OVERRIDEN,OUT_OF_SERVICE (e.g. 0000)	R
Event_State	0 - Normal	R
Out_Of_Service	0 - False	R

Object List

Analog Value Objects		Binary Value Object	
AV0	Flow	BV0	Totalizer Reset
AV1	Average Flow	BV1	Spacing Alarm
AV2	Raw Flow	BV2	Empty Alarm
AV3	Liquid Total	BV3	Rate Alarm
AV4	Sonic Velocity	BV4	Fault Alarm
AV5	Delta Time	BV5	Aeration Alarm
AV6	Valc	BV6	Memory Alarm
AV7	Aeration	BV7	Makeup Alarm
AV8	Deadband Control	BV8	Interface Alarm
AV9	Batch/Sample Total	BV9	Pig Alarm
AV10	High Flow Alarm Level	BV10	Zeromatic Alarm
AV11	Low Flow Alarm Level		
AV12	Vs Alarm Level		
AV13	Flow Velocity		
AV14	Signal		
AV15	Highest Expected Flow		
AV16	Lowest Expected Flow		
AV17	Aeration alarm Level		
AV18	Slew Mode Selection		
AV19	Time Averaging Period		
AV20	Smart Slew Seed		
AV21	Device Status		
AV22	Site Name		
AV23	Version Information		
AV24	Date/Time Last Reset		
AV25	Op Sys PN		

Analog Value Objects		Binary Value Object	
AV26	Firmware Checksum		
AV27	Compile Time Info		
AV28	System Date/Time		

A.5.3 BACnet Protocol Implementation Conformance Statement

Typical BACnet Conformance Statement

Date: April 13, 2012
Vendor Name: Siemens Industry, Inc.
Product Name: SITRANS FST020 Ultrasonic Flowmeter
Product Model Number: FST020
Application Software Version: 012813-1338
Firmware Revision: 2.04.06
BACnet Protocol Revision: 1
Product Description:
 Clamp-on ultrasonic flowmeter for liquids
BACnet Standardized Device Profile (Annex L):
 BACnet Operator Workstation (B-OWS)
 BACnet Advanced Operator Workstation (B-AWS)
 BACnet Operator Display (B-OD)
 BACnet Building Controller (B-BC)
 BACnet Advanced Application Controller (B-AAC)
 BACnet Application Specific Controller (B-ASC)
 BACnet Smart Sensor (B-SS)
 BACnet Smart Actuator (B-SA)
List all BACnet Interoperability Building blocks Supported (Annex K):
 K.1.2 BIBB – Data Sharing – ReadProperty-B (DS-RP-B)
 K.1.4 BIBB – Data Sharing – ReadPropertyMultiple-B (DS-RPM-B)
 K.1.8 BIBB – Data Sharing – WriteProperty-B (DS-WP-B)
Segmentation Capability:
 Segmented is not supported
Standard Object Types Supported:
 Device Object
 Binary Value Object
 Analog Value Object

Dynamically Creatable Object:

None

Dynamically Deletable Object:

None

Optional Properties Supported:

Device Object:

PROP_LOCAL_TIME

PROP_LOCAL_DATE

PROP_DESCRIPTION

Binary Value Object:

PROP_DESCRIPTION

Analog Value Object:

PROP_DESCRIPTION

Operational Writable Properties:

None

Operational Conditional Writable Properties:

None

Proprietary Properties:

None

Range Restrictions:

None

Data Link Layer Options:

- BACnet IP, (Annex J)
- BACnet IP, (Annex J), Foreign Device
- ISO 8802-3, Ethernet (Clause 7)
- ATA 878.1, 2.5 Mb. ARCNET (Clause 8)
- ATA 878.1, EIA-485 ARCNET (Clause 8), baud rate(s)
- MS/TP master (Clause 9), baud rate(s):
- MS/TP slave (Clause 9), baud rate(s): 300, 1200, 2400, 4800, 9600, 38400
- Point-To-Point, EIA 232 (Clause 10), baud rate(s):
- Point-To-Point, modem, (Clause 10), baud rate(s):
- LonTalk, (Clause 11), medium:
- BACnet/ZigBee (ANNEX O)
- Other:

Device Address Binding:

Is static device binding supported? (This is currently necessary for two-way communication with MS/TP slaves and certain other devices. Yes No

Networking Options:

- Router, Clause 6 - List all routing configurations, e.g., ARCNET-Ethernet, Ethernet-MS/TP, etc.
- Annex H, BACnet Tunneling Router over IP

- BACnet/IP Broadcast Management Device (BBMD)

Network Security Options:

- Non-secure Device - is capable of operating without BACnet Network Security
- Secure Device - is capable of using BACnet Network Security (NS-SD BIBB)
- Multiple Application-Specific Keys:
- Supports encryption (NS-ED BIBB)
- Key Server (NS-KS BIBB)

Character Sets Supported:

Indicating support for multiple character sets does not imply that they can all be supported simultaneously.

- ISO 10646 (UTF-8) IBM™ / Microsoft™ DBCS ISO 8859-1
- ISO 10646 (UCS-2) ISO 10646 (UCS-4) JIS X 0208 ANSI X3.4

If this product is a communication gateway, describe the types of non-BACnet equipment/networks(s) that the gateway supports:

This product is not a communications gateway.

A.5.4 ModBus

ModBus is an open protocol that has been in existence since 1980 and has become a de facto standard for communication in supervisory and data acquisition applications. It uses registers to address data which can be formatted in various types including, REAL, INTEGER, & BOOL (coils).

The following ModBus Function Codes are supported:

1	READ COIL	ReadCoil()
2	READ INPUT STATUS	ReadCoil()
3	READ HOLDING REGISTER(S)	ReadRegister()
4	READ INPUT REGISTER(S)	ReadRegister()
5	FORCE SINGLE COIL	WriteCoil()
6	PRESET SINGLE REGISTER	WriteRegister()
15	FORCE MULTIPLE COILS	WriteCoil()
16	PRESET MULTIPLE REGISTERS	WriteRegister()

Alarm Status Input Register (Read Only)

Description	Address	Register Type	Bytes	Data Type	Example
Alarm Status	295	3xxxx Input Register	16	STRING	__ERF__

Data Entry Holding Registers (Read & Write)

Description	Address	Register Type	Bytes	Data Type	Example
Aeration Alarm Level	1115	4xxxx Holding Register	2	INTEGER	50
Batch Sample Total	1107	4xxxx Holding Register	4	REAL	10.0
Deadband Control	1105	4xxxx Holding Register	4	REAL	0.0
Hi Flow Alarm Level	1109	4xxxx Holding Register	4	REAL	100.0
Lo Flow Alarm Level	1111	4xxxx Holding Register	4	REAL	10.0
Slew Mode Selection	1101	4xxxx Holding Register	2	INTEGER	1
Smart Slew	1104	4xxxx Holding Register	2	INTEGER	6
Time Average	1102	4xxxx Holding Register	4	REAL	10.0
Vs Alarm Level	1113	4xxxx Holding Register	4	REAL	2100.0

Holding Registers (Read Only)

Description	Address	Register Type	Bytes	Data Type	Example
Aeration	1015	4xxxx Holding Register	4	REAL	0.0
Average Flow	1003	4xxxx Holding Register	4	REAL	89.657
Delta Time	1011	4xxxx Holding Register	4	REAL	191.114
Liquid Flow	1001	4xxxx Holding Register	4	REAL	89.723
Liquid Total	1007	4xxxx Holding Register	4	REAL	5436.23
Raw Flow	1005	4xxxx Holding Register	4	REAL	1587.675
Signal Strength	1013	4xxxx Holding Register	4	REAL	73.0
Sonic Velocity	1009	4xxxx Holding Register	4	REAL	1495.36

Input Registers (Read Only)

Description	Addresses	Register Type	Bytes	Data Type	Example
Alarm Status	107	3xxxx Input Register	2	INTEGER	28
Day	103	3xxxx Input Register	2	INTEGER	13
Flow Velocity	1001	3xxxx Input Register	4	REAL	29.165
Highest Expected Flow	1005	3xxxx Input Register	4	REAL	260.368
Hour	104	3xxxx Input Register	2	INTEGER	16
Lowest Expected Flow	1007	3xxxx Input Register	4	REAL	-260.368
Minute	105	3xxxx Input Register	2	INTEGER	13
Month	102	3xxxx Input Register	2	INTEGER	7
Second	106	3xxxx Input Register	2	INTEGER	47
Signal	1003	3xxxx Input Register	4	REAL	195.1
Year	101	3xxxx Input Register	2	INTEGER	32 (+1980)

Coil Status

Description	Address	Register Type	Bytes	Data Type	Example
Reset Totalizer	1	0xxx Coil	1	BOOL	0

Input Status (Read Only)

Description	Address	Register Type	Bytes	Data Type	Example
Aeration	5	1xxxx Input Register	1	BOOL	1
Empty	2	1xxxx Input Register	1	BOOL	1
Fault	4	1xxxx Input Register	1	BOOL	1
Interface	8	1xxxx Input Register	1	BOOL	1
Makeup	7	1xxxx Input Register	1	BOOL	1
Memory	6	1xxxx Input Register	1	BOOL	1
Pig	9	1xxxx Input Register	1	BOOL	1
Rate	3	1xxxx Input Register	1	BOOL	1
Spacing	1	1xxxx Input Register	1	BOOL	1
Zeromatic	10	1xxxx Input Register	1	BOOL	1

Strings (Read Only)

Description	Address	Register Type	Bytes	Data Type	Example
Aeration Units	225	3xxxx Input Register	8	STRING	%
Checksum	261	3xxxx Input Register	8	STRING	09ACF200
Code Compile Info	265	3xxxx Input Register	16	STRING	050412-0724
Date Time Last Reset	241	3xxxx Input Register	20	STRING	05.04.12.08.39.57
Delta Time Units	229	3xxxx Input Register	8	STRING	nSec
Flow Units	205	3xxxx Input Register	8	STRING	CU M/HR
Flow Velocity Units	287	3xxxx Input Register	8	STRING	Feet/Sec
Liquid Total Units	213	3xxxx Input Register	8	STRING	LTR
Op Sys PN	251	3xxxx Input Register	20	STRING	FST020-2.04.06
Raw Flow Units	209	3xxxx Input Register	8	STRING	Culn/Sec
Signal Units	221	3xxxx Input Register	8	STRING	mV
Site Name	201	3xxxx Input Register	8	STRING	Chiller1
Slew Mode Units	303	3xxxx Input Register	16	STRING	Time Average
Sonic Velocity Units	217	3xxxx Input Register	8	STRING	M/S
System Time	273	3xxxx Input Register	20	STRING	07.20.12.16.48.34
Time Averaging Units	291	3xxxx Input Register	8	STRING	Sec
Valc Units	283	3xxxx Input Register	8	STRING	S
Version Info	233	3xxxx Input Register	16	STRING	2.04.06

Appendix

B.1 Installation/Outline Drawings

The following are the installation and outline drawings for the SITRANS FST020 IP65 NEMA 4X flow meter.

A5E32959662 Rev AA - Installation Drawing, 1011NFPS Series Dedicated Plastic Transducer

1011NFPS-8 Rev 002 - Outline Dimensions, 1011NFPS Series Dedicated Plastic Transducer

A5E32947129 Rev AA - Installation Drawing, 1011HNFS Series Dedicated Plastic Body Transducer

1011HNFS-8 Rev A2 - Outline Dimensions, 1011HNFS Series Dedicated Plastic Body Transducer

1012BN-8 Rev B - Outline Dimensions, 1010 Series Spacer Bar

1012FN-8 Rev B - Outline Dimensions, 1010 Series Dedicated Transducer Mounting Frames

1012MS-8 Rev F - Installation/Outline, Adjustable Mounting Strap

1012TN-7 Rev A - Installation Drawing, 1010 Series Transducer and Mounting Tracks

1012TN-8 Rev A - Outline Dimensions, 1012TN Series Mounting Track

1012TNH-7 Rev A - Installation Drawing, 1010 Series Transducer and Mounting Tracks

1012TNH-8 Rev A - Outline Dimensions, 1012 Series Mounting Tracks

990TDMVH-7B Rev F - Installation Drawing, 990 Series Transducer and Assembly, Very High Temp., Direct Mode

990TRMVH-7B Rev F - Installation Drawing, 990 Series Transducer and Assembly, Very High Temp., Reflect Mode

990THMVH-8B Rev D - Outline Dimensions, Transducers and Tracks, Dedicated, Hybrid Mode

INSTALLATION NOTES - SEE DRAWING REFERENCE **A**

1. USING THE INSTALLATION MENU AND THE PROCEDURE OUTLINED IN THE FLOW COMPUTER FIELD MANUAL, CONFIRM THAT YOU HAVE THE APPROPRIATE SENSORS AND SPACER BAR (IF USED) FOR REFLECT MODE OPERATION ON THE CHOSEN PIPE.
2. SELECT MOUNTING LOCATION:
 - 2.1. CHOOSE LOCATION WHICH REMAINS FULL AT ZERO FLOW
 - 2.2. WHERE POSSIBLE, LOCATE SENSORS TO PIPE DIAMETERS OR MORE FROM BEND TO ENSURE FULLY DEVELOPED AND STABLE FLOW PROFILE.
 - 2.3. ON HORIZONTAL PIPE, SELECT HORIZONTAL PLANE. IF POSSIBLE, TO AVOID SEDIMENT BLOCKAGE OF ULTRASONIC BEAM.
3. PREPARE PIPE FOR TRACK MOUNTING:
 - 3.1. REMOVE GRIT, CORROSION, COATING OR HEAVY PAINT
 - 3.2. CLEAN AND DEGREASE SURFACE
 - 3.3. DO NOT MOUNT OVER FROST.
 - 3.4. CONDITION PIPE SURFACE:
 - LOCALLY SMOOTH THE PIPE SURFACE TO ACCEPT THE SENSORS. USE THE ABRASIVE PAD PROVIDED.
4. INSTALLATION WITH MOUNTING FRAMES
 - 4.1. CONSULT THE 1010 FIELD MANUAL AND USE THE INSTALLATION MENU TO SELECT THE APPROPRIATE INDEX HOLE OR SPACING (LIN) FOR YOUR APPLICATION.
 - 4.2. IF SPACER BAR IS USED:
 - 4.2.1. CLAMP ONE MOUNTING FRAME AT THE UN-NUMBERED REFERENCE POSITION OF THE SPACER BAR. BE SURE THE INDEX PIN AND SPACER BAR INDEX SCREW ENGAGE THE HOLE IN THE SPACER BAR.
 - 4.2.2. CLAMP THE SECOND MOUNTING FRAME TO THE SPACER BAR IN THE SAME MANNER AT THE INDEX HOLE INDICATED DURING STEP 4.1.
 - 4.2.3. HOLD THE MOUNTING FRAME/SPACER BAR ASSEMBLY ON THE PIPE AT THE SELECTED LOCATION AND TEMPORARILY SECURE IT TO THE PIPE USING STRAPS FROM THE 1012MS STRAP MOUNTING KIT. GO TO 4.4.
 - 4.3. IF MOUNTING FRAMES ARE SPACED BY MEASURING "LIN":
 - 4.3.1. TEMPORARILY SECURE ONE OF THE MOUNTING FRAMES TO THE PIPE USING STRAPS FROM THE 1012MS STRAP MOUNTING KIT.
 - 4.3.2. MEASURE ALONG THE PIPE AND TEMPORARILY SECURE THE SECOND MOUNTING FRAME TO THE PIPE SO THAT SPACING "LIN" DETERMINED IN STEP 4.1 IS MEASURED BETWEEN THE MOUNTING FRAMES.
 - 4.4. IF THE PIPE SURFACE IS CLEAN AND SMOOTH, PROCEED TO SENSOR INSTALLATION ON SH3.3. IF PIPE SURFACE NEEDS CONDITIONING, MARK THE MOUNTING FRAME POSITION CAREFULLY, LOOSEN STRAPS AND MOVE THE MOUNTING FRAMES ASIDE. LOCALLY SMOOTH THE PIPE SURFACE IN THE MARKED AREAS USING THE ABRASIVE PAD SUPPLIED. SHIFT THE MOUNTING FRAMES BACK INTO THEIR APPROPRIATE LOCATIONS AND TIGHTEN THE MOUNTING STRAPS SECURELY.

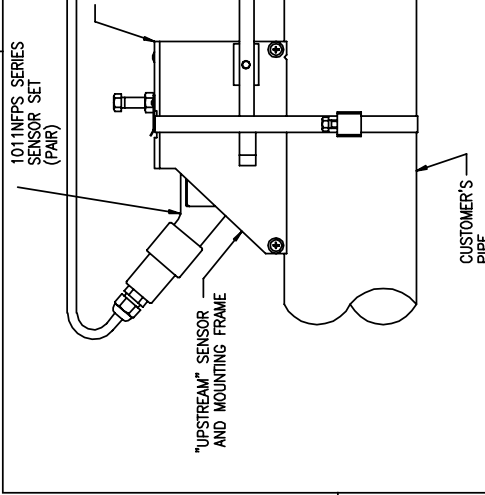
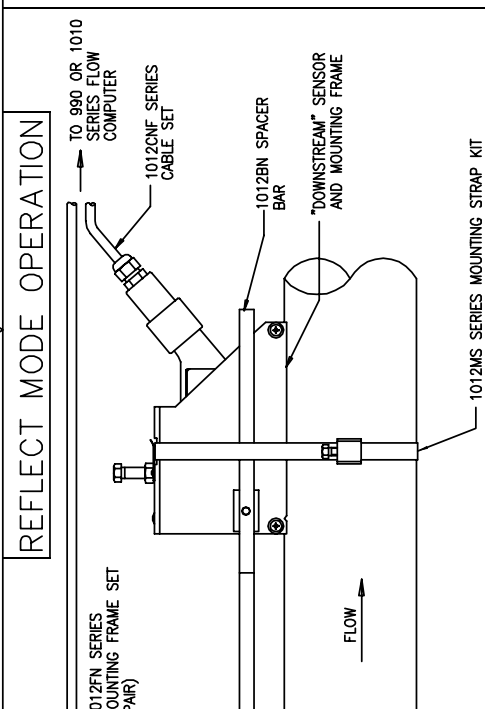

REFLECT MODE OPERATION

TO 990 OR 1010 SERIES FLOW COMPUTER

1012FN SERIES MOUNTING FRAME SET (PAIR)

1012BN SPACER BAR

"DOWNSTREAM" SENSOR AND MOUNTING FRAME

1012MS SERIES MOUNTING STRAP KIT

CUSTOMER'S PIPE

FLOW

SECURING MOUNTING FRAMES TO THE PIPE SURFACE

HOLD THE MOUNTING FRAME/SPACER BAR ASSEMBLY AGAINST THE PIPE AT THE SELECTED MOUNTING LOCATION. MARK THE APPROXIMATE OUTLINE OF THE MOUNTING FRAMES ON THE PIPE SURFACE. USING THE ABRASIVE PAD SUPPLIED, SMOOTH THE PIPE SURFACE IN THE MARKED AREAS. SECURE THE MOUNTING FRAMES TO THE PIPE USING THE MOUNTING STRAP KIT (1012MS). SEE DRAWING 1012MS-8.

ABRADE TO SMOOTH FINISH, TWO PLACES

4.4

4.2

4.3

PREFERRED MOUNTING PLANE

HORIZONTAL

2.3

MOUNT SENSORS/MOUNTING FRAMES IN HORIZONTAL PLANE TO PREVENT BLOCKING OF ULTRASONIC BEAM BY AIR OR SEDIMENT.

USING THE SPACER BAR TO SET SENSOR MOUNTING FRAME SPACING

USE THE SPACER BAR INDEX SCREW TO SECURE THE SPACER BAR TO ONE OF THE MOUNTING FRAMES AT THE UN-NUMBERED REFERENCE POSITION.

SPACER BAR INDEX SCREW

UN-NUMBERED REFERENCE POSITION

NUMBERED INDEX POSITIONS

SPACER BAR

4.2

4.3

SECURE THE SECOND MOUNTING FRAME TO THE SPACER BAR AT THE NUMBERED INDEX POSITION DETERMINED FROM THE INSTALLATION MENU.

SEE SHEET 3 FOR INSTRUCTIONS TO COMPLETE SENSOR INSTALLATION.

SEE SHEET 4 FOR SENSOR INSTALLATION WITHOUT MOUNTING FRAMES

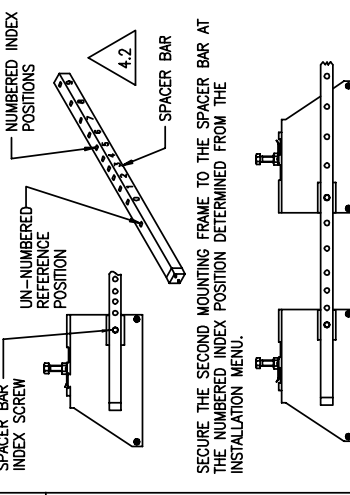

SIEMENS
Siemens Industry Inc.
Industry Automation Division
Hempstead, NY 11788

INSTALLATION, 1011NPF5 SERIES DEDICATED PLASTIC BODY SENSOR

SAP MATERIAL NO.	A5E32959662	REV AA
ITEM NO.	A5E32959662	RS AA
DOCUMENT NO.	1011NPF5 - 7	REV 003
DATE: 9/30/2013	SCALE: NONE	SHEET 1 OF 4

UNLESS OTHERWISE SPECIFIED, DIMENSIONS ARE IN INCHES

TOLERANCES ON:

FRACTIONS	DECIMAL	ANGLES	HOLES
± 1/64"	XX.XX/01	±0°30'	±.003
	XXX.X/0.005		

DRAWN BY: H.Jenkins

INSTALLATION NOTES - SEE DRAWING REFERENCE

1. USING THE INSTALLATION MENU AND THE PROCEDURE OUTLINED IN THE FLOW COMPUTER FIELD MANUAL, CONFIRM THAT YOU HAVE THE APPROPRIATE SENSORS AND SPACER BAR (IF USED) FOR DIRECT MODE OPERATION ON THE CHOSEN PIPE.
2. SELECT MOUNTING LOCATION;
 - 2.1 CHOOSE LOCATION WHICH REMAINS FULL AT ZERO FLOW.
 - 2.2 WHERE POSSIBLE, LOCATE SENSORS TO PIPE DIAMETERS OR WIDE PROFILE.
 - 2.3 ON HORIZONTAL PIPE, SELECT HORIZONTAL PLANE IF POSSIBLE TO AVOID SEDIMENT BLOCKAGE OF ULTRASONIC BEAM.
3. PREPARE PIPE FOR STRAP MOUNTING;
 - 3.1 REMOVE OIL, GREASE, COATING OR HEAVY PAINT
 - 3.2 CLEAN AND DEGREASE SURFACE.
 - 3.3 DO NOT MOUNT OVER FROST.
 - 3.4 CONDITION PIPE SURFACE.
4. INSTALLATION WITH MOUNTING FRAMES
 - 4.1 CONSULT THE 1010 FIELD MANUAL AND USE THE INSTALLATION MENU TO SELECT THE APPROPRIATE INDEX HOLE OR SPACING (LTN) FOR YOUR APPLICATION.
 - 4.2 IF SPACER BAR IS USED:
 - 4.2.1 CLAMP ONE MOUNTING FRAME AT THE UN-NUMBERED REFERENCE POSITION OF THE SPACER BAR. BE SURE THE INDEX PIN AND SPACER BAR INDEX SCREW ENGAGE THE HOLE IN THE SPACER BAR.
 - 4.2.2 CLAMP THE SECOND MOUNTING FRAME TO THE SPACER BAR IN THE SAME MANNER AT THE INDEX HOLE INDICATED DURING STEP 4.1.
 - 4.2.3 HOLD THE MOUNTING FRAME/SPACER BAR ASSEMBLY ON THE PIPE AT THE POSITION INDICATED IN THE 1012MS STRAP MOUNTING KIT. GO TO 4.4.
 - 4.3 IF MOUNTING FRAMES ARE SPACED BY MEASURING "LTN":
 - 4.3.1 TEMPORARILY SECURE ONE OF THE MOUNTING FRAMES TO THE PIPE USING STRAPS FROM THE 1012MS STRAP MOUNTING KIT.
 - 4.3.2 MEASURE ALONG THE PIPE AND TEMPORARILY SECURE THE SECOND MOUNTING FRAME TO THE PIPE. THE DISTANCE BETWEEN THE MOUNTING FRAMES IS MEASURED BETWEEN THE SPACING MARKS ON THE MOUNTING FRAMES. USE STRAIGHT EDGE OR OTHER MEANS TO ALIGN BOTH MOUNTING FRAMES WITH PIPE AXIS.
 - 4.4 USE THE MOUNTING GUIDE INCLUDED WITH THE 1012MS STRAP MOUNTING KIT TO TRANSFER ONE OF THE MOUNTING FRAMES TO THE OPPOSITE SIDE OF THE PIPE.
 - 4.4.1 WRAP THE MOUNTING GUIDE AROUND THE PIPE. POSITION IT SO THAT THE OVERLAPPING LENGTHS ARE EDGE-ALIGNED. MARK THE OVERLAPPED PORTION OF THE GUIDE AT THE EDGE OF THE OVERLAPPING PORTION. REMOVE THE GUIDE. MEASURE THE DISTANCE FROM THE END TO THE MARK AND MARK AGAIN HALFWAY BETWEEN.
 - 4.4.2 RE-POSITION THE GUIDE ON THE PIPE AND TAPE IN PLACE SO THAT ONE OF THE MARKS INDICATES THE CENTERLINE OF THE INSTALLED MOUNTING FRAMES AND THE MOUNTING GUIDE EDGE IS AGAINST THE END OF ONE OF THE MOUNTING FRAMES. MAKE SURE THE OVERLAPPING LENGTHS OF THE MOUNTING GUIDE ARE EDGE-ALIGNED. THIS ASSURES A DIMETRICAL TRANSFER OF THE MOUNTING FRAME POSITION.
 - 4.4.3 LOOSEN THE MOUNTING STRAP ON THE MOUNTING FRAME WITH THE STRAP CUTTERS. REMOVE THE STRAP. CENTER THE OPPOSITE SIDE MOUNTING PIPE MARK MADE IN STEP 4.4.1. TIGHTEN THE STRAP. REMOVE THE MOUNTING GUIDE.
 - 4.5 IF THE PIPE SURFACE IS CLEAN AND SMOOTH, PROCEED TO SENSOR INSTALLATION ON STEP 5. IF THE PIPE SURFACE NEEDS CONDITIONING, MARK THE MOUNTING FRAMES ASIDE. LOCALLY SMOOTH THE PIPE SURFACE IN THE MARKED AREAS USING THE ABRASIVE PAD SUPPLIED. SHUT THE MOUNTING FRAMES BACK INTO THEIR APPROPRIATE LOCATIONS AND TIGHTEN THE MOUNTING STRAPS SECURELY.

**** SEE SHEET 3 FOR INSTRUCTIONS TO COMPLETE SENSOR INSTALLATION.**

DIRECT MODE OPERATION

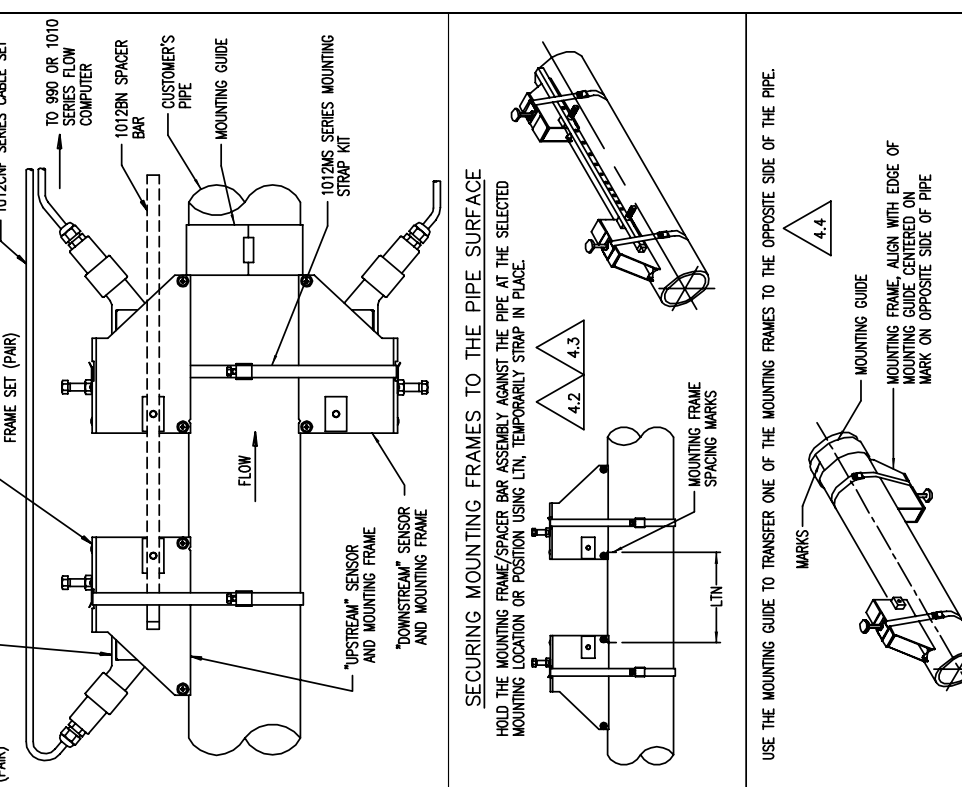

PREFERRED MOUNTING PLANE

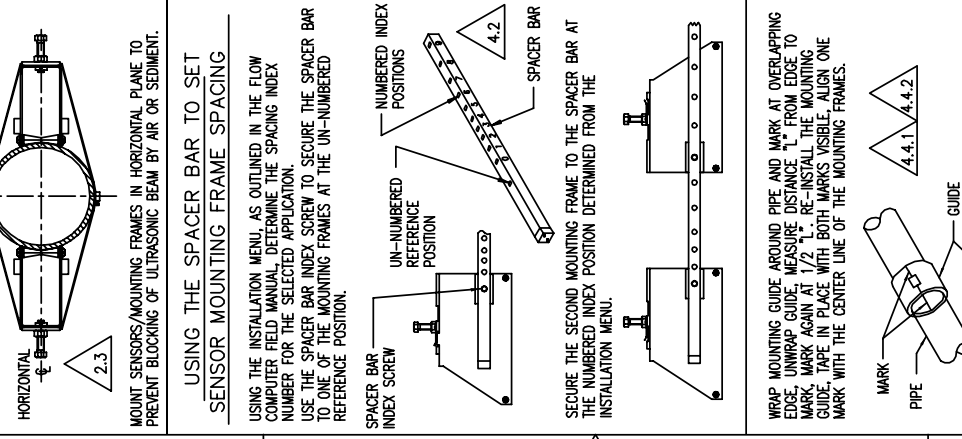

USING THE SPACER BAR TO SET SENSOR MOUNTING FRAME SPACING

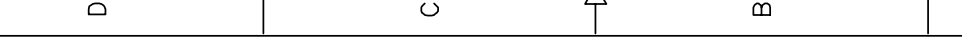

WRAP MOUNTING GUIDE AROUND PIPE AND MARK AT OVERLAPPING EDGE. UNWRAP GUIDE. MEASURE DISTANCE "L" FROM EDGE TO MARK. MARK AGAIN AT 1/2 "L". RE-INSTALL THE MOUNTING GUIDE. TAPE IN PLACE WITH BOTH MARKS VISIBLE. ALIGN ONE MARK WITH THE CENTER LINE OF THE MOUNTING FRAMES.



IF NECESSARY, USE THE ABRASIVE PAD SUPPLIED TO PRODUCE A SMOOTH FINISH ON THE PIPE AT THE SENSOR MOUNTING POSITIONS.



<p>SIEMENS Siemens Industry, Inc. Industry Automation Division Hauppauge, NY 11788</p>		<p>INSTALLATION, 1011NFPFS SERIES DEDICATED PLASTIC BODY SENSOR</p>	
		<p>SAP MATERIAL NO. A5E32959662</p>	<p>REV AA</p>
<p>ITEM NO. A5E32959662</p>		<p>RS AA</p>	
<p>DOCUMENT NO. 1011NFPFS - 7</p>		<p>REV 003</p>	
<p>DATE: 9/30/2013</p>		<p>SCALE: NONE</p>	<p>SHEET 2 OF 4</p>

<p>UNLESS OTHERWISE SPECIFIED: DIMENSIONS ARE IN INCHES TOLERANCES ON- FRACTIONS DECIMAL ANGLES ± 1/64" X X40.01 ±0°30' ±.003 XXX40.005</p>	<p>HOLES ±.003</p>
---	------------------------

<p>UNLESS OTHERWISE SPECIFIED: DIMENSIONS ARE IN INCHES TOLERANCES ON- FRACTIONS DECIMAL ANGLES ± 1/64" X X40.01 ±0°30' ±.003 XXX40.005</p>	<p>HOLES ±.003</p>
---	------------------------

1

2

3

4

1

2

3

4

1

2

3

4

1

2

3

4

1

2

3

4

1

2

3

4

1

2

3

4

1

2

3

4

1

2

3

4

1

2

3

4

1

2

3

4

1

2

3

4

1

2

3

4

1

2

3

4

1

2

3

4

1

2

3

4

1

2

3

4

1

2

3

4

1

2

3

4

1

2

3

4

1

2

3

4

1

2

3

4

1

2

3

4

1

2

3

4

1

2

3

4

1

2

3

4

1

2

3

4

1

2

3

4

1

2

3

4

1

2

3

4

1

2

3

4

1

2

3

4

1

2

3

4

1

2

3

4

1

2

3

4

1

2

3

4

1

2

3

4

1

2

3

4

1

2

3

4

1

2

3

4

1

2

3

4

1

2

3

4

1

2

3

4

1

2

3

4

1

2

3

4

1

2

3

4

1

2

3

4

1

2

3

4

1

2

3

4

1

2

3

4

1

2

3

4

1

2

3

4

1

2

3

4

1

2

3

4

1

2

3

4

1

2

3

4

1

2

3

4

1

2

3

4

1

2

3

4

1

2

4

MATING 1012CNF SERIES SENSOR CABLES WITH 1011NFPs SERIES TRANSDUCERS

- a) REMOVE PROTECTIVE CAPS.
- b) SEE APPROPRIATE CABLE ASSEMBLY DRAWING FOR 'F' CONNECTOR, NPT ADAPTER AND GLAND ASSEMBLY DETAIL.
- c) MATE 'F' CONNECTORS, CABLES TO TRANSDUCER.
- d) FOR BEST WEATHER SEAL, WRAP TEFLON PIPE TAPE (NOT SUPPLIED) AROUND MALE NPT THREADS ON SENSOR HOUSING.
- e) SCREW NPT ADAPTER TO SENSOR HOUSING (HAND TIGHT IS SUFFICIENT).
- f) TIGHTEN GLAND BODY WITH NPT ADAPTER AND SECURE CABLE BY TIGHTENING GLAND TOP NUT. (HAND TIGHT IS SUFFICIENT).

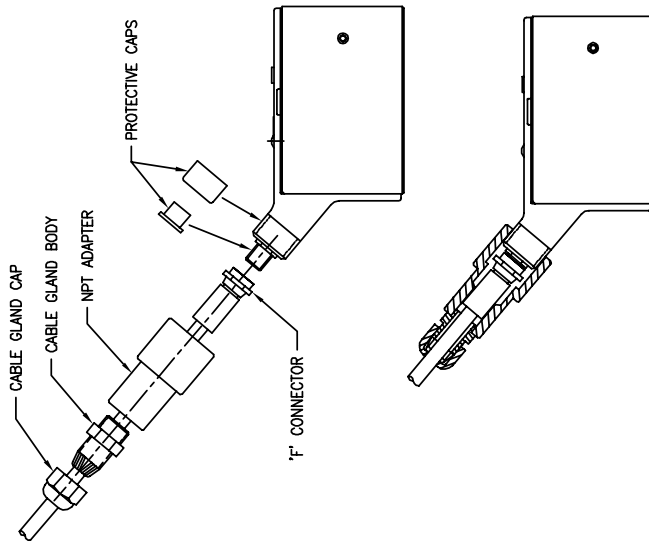

3

INSTALLING SENSORS IN MOUNTING FRAMES

APPLY A THIN BAND OF COUPLANT TO THE EMITTING SURFACE OF THE SENSORS. SLIP THE SENSORS INTO THE MOUNTING FRAMES, SEATING THEM SQUARELY ON THE PIPE SURFACE. PUSH FORWARD INTO THE FRAMES AGAINST THE FRONT SPACER. TIGHTEN THE SENSOR CLAMPING SCREW, FIRMLY SEATING THE SENSORS ON THE PIPE SURFACE. SECURE THE CLAMPING SCREW WITH THE LOCKNUT.

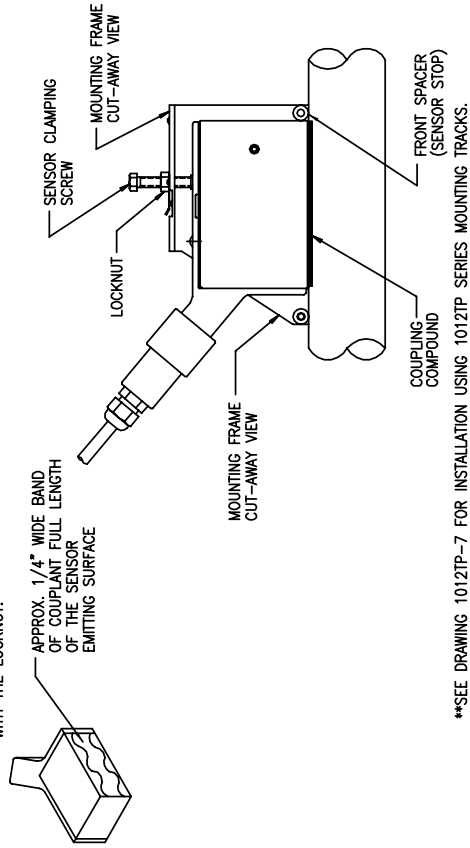

**SEE DRAWING 1012TP-7 FOR INSTALLATION USING 1012TP SERIES MOUNTING TRACKS.

USE OF FLEXIBLE CONDUIT WITH SENSORS

THE SENSOR WIRING HOUSING HAS INTEGRAL 1/2" N.P.T. THREADS TO ACCEPT A CONDUIT COUPLING IF FLEXIBLE CONDUIT IS USED. MAKE CONNECTION AS SHOWN, THEN PASS COUPLING AND CONDUIT OVER THE CABLE, SECURE TO THE SENSOR WIRING HOUSING.

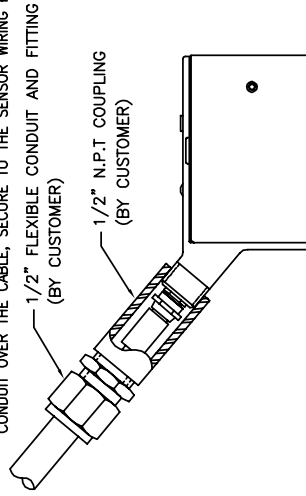

2

1

INSTALLATION NOTES - CONT'D FROM SHIT. 1 OR SHIT. 2

- 5. MAKE CABLE CONNECTIONS AT FLOW COMPUTER IN ACCORDANCE WITH APPROPRIATE FLOW COMPUTER INSTALLATION DRAWING AND 1010 FIELD MANUAL.
- 6. SEE DRAWINGS 1012FN-8 AND 1011NFPs-8 FOR MOUNTING FRAME AND SENSOR OUTLINE DIMENSIONS.

SIEMENS
Siemens Industry, Inc.
Industry Automation Division
Hauptstraße, NY 11788

INSTALLATION, 1011NFPs SERIES DEDICATED PLASTIC BODY SENSOR

SAP MATERIAL NO.	A5E32959662	REV AA
ITEM NO.	A5E32959662	RS AA
DOCUMENT NO.	1011NFPs - 7	REV 003
DATE: 9/30/2013	SCALE: NONE	SHEET 3 OF 4

UNLESS OTHERWISE SPECIFIED:
DIMENSIONS ARE IN INCHES
TOLERANCES ON:
FRACTIONS DECIMAL ANGLES HOLES
±.184" Xx60.01 ±0.030 ±.003
XXX60.005

DRAWN BY: H.Jenkins

4

3

2

1

INSTALLATION OF SENSORS WITHOUT MOUNTING FRAMES

THE SAME GENERAL NOTES AND PROCEDURES APPLY WHEN INSTALLING SENSORS WITHOUT THE BENEFIT OF MOUNTING FRAMES. APPLY THE FOLLOWING ALTERNATES TO THE INSTALLATION NOTES ON SHEETS 1 & 2.

4.2 IF SPACER BAR IS USED:
 dlt.4.2.1 SECURE ONE SENSOR AT THE UN-NUMBERED REFERENCE POSITION OF THE SPACER BAR BY ENGAGING ONE OF THE SCREWS STOWED IN THE SPACER BAR CAP WITH THE THREADED INSERT IN THE SIDE OF THE SENSOR BLOCK.
 dlt.4.2.2 SECURE THE SECOND SENSOR TO THE SPACER BAR IN THE SAME MANNER AT THE INDEX HOLE INDICATED DURING STEP 4.1.
 dlt.4.2.3 HOLD SENSOR/SPACER BAR ASSEMBLY ON THE PIPE AT THE SELECTED LOCATION AND TEMPORARILY SECURE IT TO THE PIPE USING STRAPS FROM THE 1012MS STRAP MOUNTING KIT.

4.3 IF SENSORS ARE SPACED BY MEASURING "LTN":
 dlt.4.3.1 TEMPORARILY SECURE ONE OF THE SENSORS TO THE PIPE USING STRAPS FROM THE 1012MS STRAP MOUNTING KIT.
 dlt.4.3.2 MEASURE ALONG THE PIPE AND TEMPORARILY SECURE THE SECOND SENSOR TO THE PIPE SO THAT SPACING "LTN" DETERMINED IN STEP 4.1 IS MEASURED BETWEEN THE SPACING MARKS ON THE FRONT FACES OF THE SENSORS. USE A STRAIGHT EDGE OR OTHER MEANS TO ALIGN BOTH SENSORS WITH THE PIPE AXIS.

FOR REFLECT MODE INSTALLATION GO TO STEP dlt.4.5
 FOR DIRECT MODE INSTALLATION CONTINUE WITH dlt.4.4

dlt.4.4 USE THE MOUNTING GUIDE INCLUDED WITH THE 1012MS STRAP MOUNTING KIT TO TRANSFER ONE OF THE SENSORS TO THE OPPOSITE SIDE OF THE PIPE. (SEE SHEET 2, ZONE AA)

dlt.4.4.1 WRAP THE MOUNTING GUIDE AROUND THE PIPE. POSITION IT SO THAT THE OVERLAPPING LENGTHS ARE EDGE-ALIGNED. MARK THE OVERLAPPED PORTION OF THE GUIDE AT THE EDGE OF THE OVERLAPPING PORTION. REMOVE THE GUIDE. MEASURE THE DISTANCE FROM THE END TO THE MARK AND MARK AGAIN HALFWAY BETWEEN.

dlt.4.4.2 RE-POSITION THE GUIDE ON THE PIPE AND TAPE IN PLACE SO THAT ONE OF THE MARKS INDICATES THE CENTERLINE OF THE INSTALLED SENSOR AND THE MOUNTING GUIDE EDGE IS AGAINST THE END OF ONE OF THE SENSORS. MAKE SURE THE OVERLAPPING LENGTHS OF THE MOUNTING GUIDE ARE EDGE-ALIGNED. THIS ASSURES A DIAMETRICAL TRANSFER OF THE SENSOR POSITION.

dlt.4.4.3 LOOSEN THE MOUNTING STRAP ON THE SENSOR WITH WHICH THE MOUNTING GUIDE HAS BEEN ALIGNED. ROTATE IT AROUND THE PIPE SURFACE UNTIL IT IS CENTERED ON THE OPPOSITE SIDE MOUNTING GUIDE MARK MADE IN STEP dlt.4.4.1. TIGHTEN THE STRAP. REMOVE THE MOUNTING GUIDE.

dlt.4.5 WITH THE SENSORS TEMPORARILY STRAPPED IN PLACE, MARK THE PIPE SURFACE AT THE SENSOR PERIMETER. REMOVE THE SENSORS FROM THE PIPE. IF THE PIPE SURFACE IS CLEAN AND CONDUCIVE, REMOVE THE STRAP AND THE MOUNTING GUIDE. IF THE PIPE SURFACE IS NOT CONDUCTIVE, LOCALLY SAND THE SURFACE IN THE MARKED AREAS USING THE ABRASIVE PAD SUPPLIED. DO NOT OBSCURE THE MARKED SENSOR LOCATIONS.

dlt.4.6 APPLY A THIN BAND OF COMPLANT TO THE EMITTING SURFACE OF BOTH SENSORS. CAREFULLY REPLACE THE SENSORS ON THE PIPE, REPEATING THE PROCEDURE ABOVE, IF REQUIRED, TO ASSURE ACCURATE POSITIONING.
 CONTINUE WITH INSTALLATION NOTE 5 AND CABLE CONNECTING INSTRUCTIONS ON SHEET 3.

REFLECT MODE OPERATION

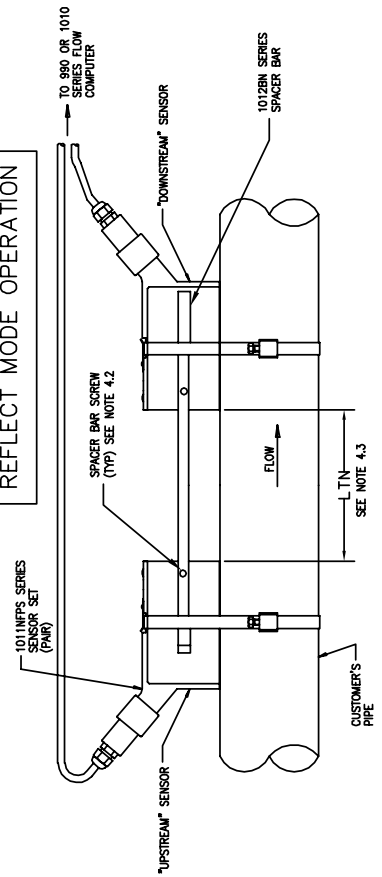

DIRECT MODE OPERATION

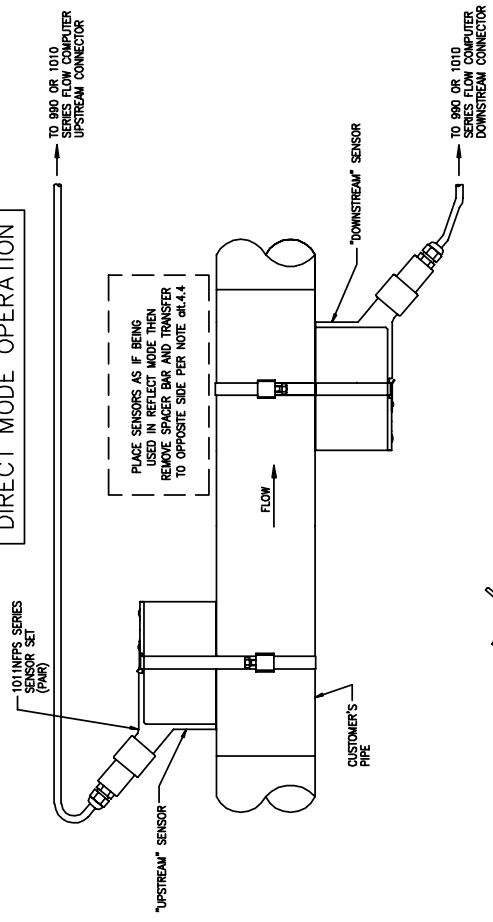

AUXILIARY VIEW

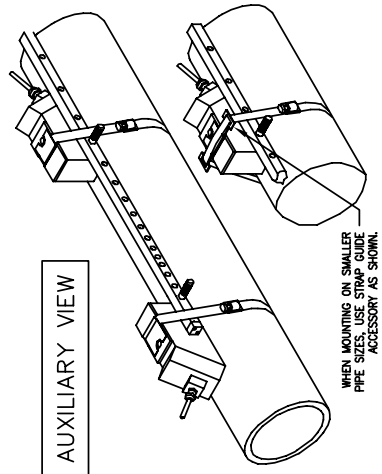

Siemens Industry, Inc.
 Industry Automation Division
 Hauppauge, NY 11788

UNLESS OTHERWISE SPECIFIED: DIMENSIONS ARE IN INCHES TOLERANCES ON: FRACTIONS DECIMAL ANGLES HOLES ±.164" X.60.01 ±0.30 ±.003 XXX.60.006		INSTALLATION, 1011NFPs SERIES DEDICATED PLASTIC BODY SENSOR	
SAP MATERIAL NO.	A5E32959662	REV AA	REV AA
ITEM NO.	A5E32959662	RS AA	RS AA
DOCUMENT NO.	1011NFPs - 7	REV 003	REV 003
DATE: 9/20/2013	SCALE: NONE	SHEET 4	OF 4

DRAWN BY: H.Jenkins

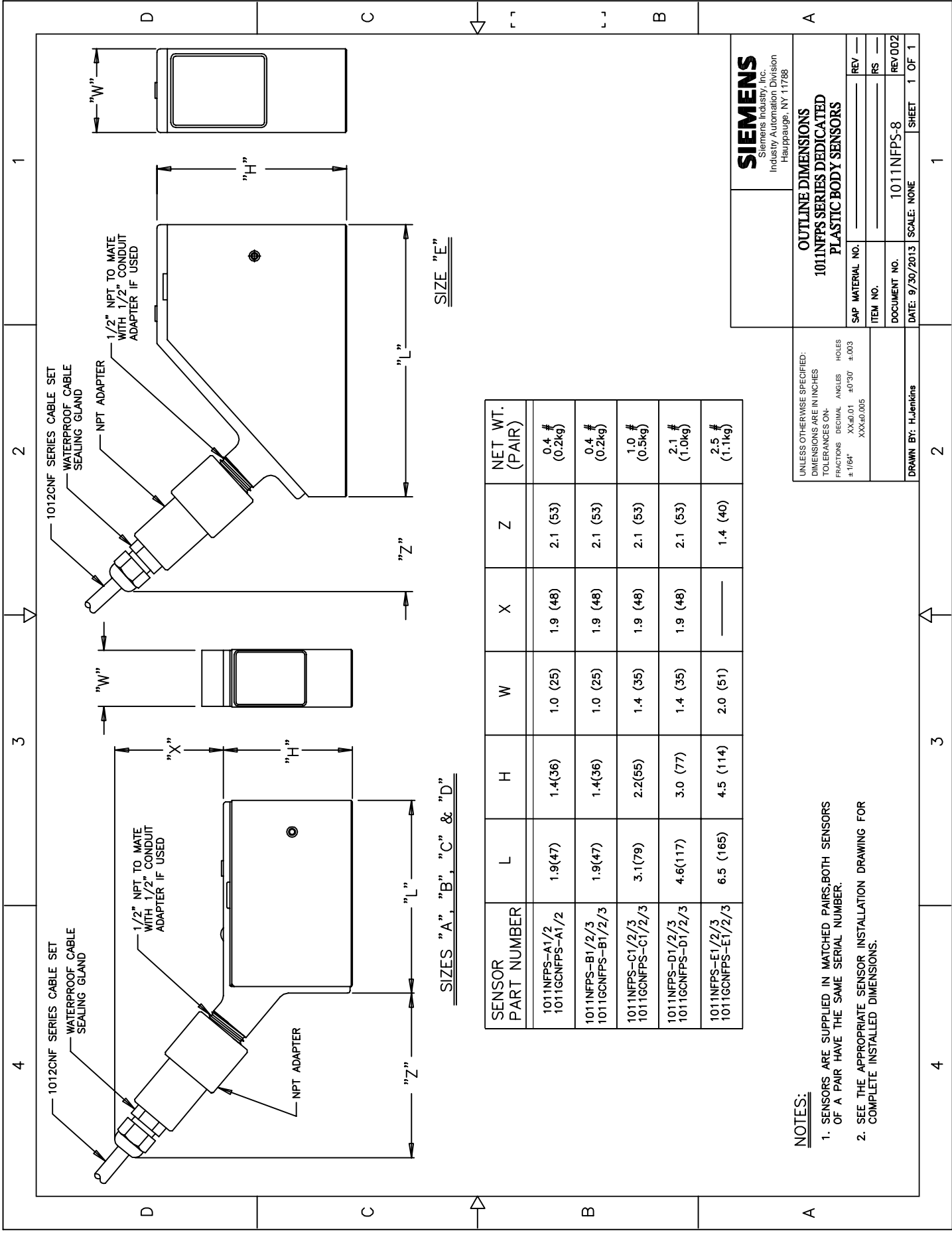

SIZE "E"

SIZES "A", "B", "C" & "D"

SENSOR PART NUMBER	L	H	W	X	Z	NET WT. (PAIR)
1011NFPS-A1/2 1011GCNFPS-A1/2	1.9(47)	1.4(36)	1.0 (25)	1.9 (48)	2.1 (53)	0.4 # (0.2kg)
1011NFPS-B1/2/3 1011GCNFPS-B1/2/3	1.9(47)	1.4(36)	1.0 (25)	1.9 (48)	2.1 (53)	0.4 # (0.2kg)
1011NFPS-C1/2/3 1011GCNFPS-C1/2/3	3.1(79)	2.2(55)	1.4 (35)	1.9 (48)	2.1 (53)	1.0 # (0.5kg)
1011NFPS-D1/2/3 1011GCNFPS-D1/2/3	4.6(117)	3.0 (77)	1.4 (35)	1.9 (48)	2.1 (53)	2.1 # (1.0kg)
1011NFPS-E1/2/3 1011GCNFPS-E1/2/3	6.5 (165)	4.5 (114)	2.0 (51)	—	1.4 (40)	2.5 # (1.1kg)

SIEMENS
Siemens Industry, Inc.
Industry Automation Division
Hempstead, NY 11788

OUTLINE DIMENSIONS			
1011NFPS SERIES DEDICATED PLASTIC BODY SENSORS			
SAP MATERIAL NO.	REV.	RS	REV002
ITEM NO.			
DOCUMENT NO.	1011NFPS-8		SHEET 1 OF 1
DATE: 9/30/2013	SCALE: NONE		

UNLESS OTHERWISE SPECIFIED:
DIMENSIONS ARE IN INCHES
TOLERANCES ON:
FRACTIONS DECIMAL ANGLES HOLES
±.1/64" XX.40.01 ±0°30' ±.003
XXX.40.005

DRAWN BY: H.Jenkins

- NOTES:**
- SENSORS ARE SUPPLIED IN MATCHED PAIRS, BOTH SENSORS OF A PAIR HAVE THE SAME SERIAL NUMBER.
 - SEE THE APPROPRIATE SENSOR INSTALLATION DRAWING FOR COMPLETE INSTALLED DIMENSIONS.

INSTALLATION NOTES - SEE DRAWING REFERENCE **A**

1. USING THE INSTALLATION MENU AND THE PROCEDURE OUTLINED IN THE FLOW COMPUTER FIELD MANUAL, CONFIRM THAT YOU HAVE THE APPROPRIATE SENSORS AND SPACER BAR (IF USED) FOR REFLECT MODE OPERATION ON THE CHOSEN PIPE.
2. SELECT MOUNTING LOCATION:
 - 2.1 CHOOSE LOCATION WHICH REMAINS FULL AT ZERO FLOW.
 - 2.2 WHERE POSSIBLE LOCATE TRACK ASSY TO PIPE DIAMETERS OR MORE FROM BEND TO ENSURE FULLY DEVELOPED AND STABLE FLOW PROFILE.
 - 2.3 ON HORIZONTAL PIPE, SELECT HORIZONTAL PLANE, IF POSSIBLE, TO AVOID SEDIMENT BLOCKAGE OF ULTRASONIC BEAM.
3. PREPARE PIPE FOR TRACK MOUNT:
 - 3.1 REMOVE GRIT, CORROSION, COATING OR HEAVY PAINT
 - 3.2 CLEAN AND DECREASE SURFACE
 - 3.3 DO NOT MOUNT OVER FROST.
 - 3.4 CONDITION PIPE SURFACE TO ACCEPT THE SENSORS. USE THE ABRASIVE PAD PROVIDED.
4. LOCATE MOUNTING FRAMES:
 - 4.1 CONSULT THE 1010 FIELD MANUAL AND USE THE INSTALLATION MENU TO SELECT THE APPROPRIATE INDEX HOLE OR SPACING (LTN) FOR YOUR APPLICATION.
 - 4.2 IF SPACER BAR IS USED:
 - 4.2.1 CLAMP ONE MOUNTING FRAME AT THE UN-NUMBERED REFERENCE POSITION OF THE SPACER BAR. BE SURE THE SPACER BAR INDEX SCREW FITS THROUGH THE HOLE IN THE SPACER BAR AND ENGAGES THE HOLE IN THE MOUNTING FRAME BLOCK.
 - 4.2.2 CLAMP THE SECOND MOUNTING FRAME TO THE SPACER BAR IN THE SAME MANNER AT THE INDEX HOLE INDICATED DURING STEP 4.1.
 - 4.2.3 HOLD THE MOUNTING FRAME/SPACER BAR ASSEMBLY ON THE PIPE AT THE SELECTED LOCATION AND TEMPORARILY SECURE IT TO THE PIPE USING STRAPS FROM THE 1012MS STRAP MOUNTING KIT. GO TO 4.4.
 - 4.3 IF MOUNTING FRAMES ARE SPACED BY MEASURING "LTN":
 - 4.3.1 TEMPORARILY SECURE ONE OF THE MOUNTING FRAMES TO THE PIPE USING STRAPS FROM THE 1012MS STRAP MOUNTING KIT.
 - 4.3.2 MEASURE ALONG THE PIPE AND TEMPORARILY SECURE THE SECOND MOUNTING FRAME TO THE PIPE SO THAT SPACING "LTN" DETERMINED IN STEP 4.1 IS MEASURED BETWEEN THE SPACING MARKS ON THE MOUNTING FRAMES.
 - 4.4 IF THE PIPE SURFACE IS CLEAN AND SMOOTH, PROCEED TO THE SENSOR INSTALLATION ON STEP 3.3. IF PIPE SURFACE NEEDS CONDITIONING, MARK THE MOUNTING FRAMES POSITION CAREFULLY, LOOSEN THE SPACER BAR AND MOVE THE MARKED AREAS USING THE ABRASIVE PAD SUPPLIED. SHIFT THE MOUNTING FRAMES BACK INTO THEIR APPROPRIATE LOCATIONS AND TIGHTEN THE MOUNTING STRAPS SECURELY.

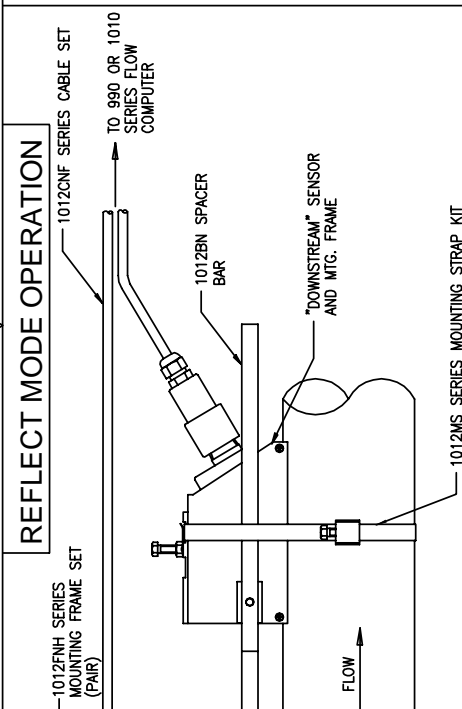

REFLECT MODE OPERATION

SECURING MOUNTING FRAMES TO THE PIPE SURFACE

HOLD THE MOUNTING FRAME/SPACER BAR ASSEMBLY AGAINST THE PIPE AT THE SELECTED MOUNTING LOCATION. MARK THE APPROXIMATE OUTLINE OF THE MOUNTING FRAMES ON THE PIPE SURFACE. USING THE ABRASIVE PAD SUPPLIED, SMOOTH THE PIPE SURFACE IN THE MARKED AREAS. SECURE THE MOUNTING FRAMES TO THE PIPE USING THE MOUNTING STRAP KIT (1012MS). SEE DRAWING 1012MS-8.

PREPARED MOUNTING PLANE

USING THE SPACER BAR TO SET SENSOR MOUNTING FRAME SPACING

USING THE INSTALLATION MENU, AS OUTLINED IN THE FLOW COMPUTER FIELD MANUAL, DETERMINE THE SPACING INDEX NUMBER FOR THE SELECTED APPLICATION.

USE THE SPACER BAR INDEX SCREW TO SECURE THE SPACER BAR TO ONE OF THE MOUNTING FRAMES AT THE UN-NUMBERED REFERENCE POSITION.

SECURE THE SECOND MOUNTING FRAME TO THE SPACER BAR AT THE NUMBERED INDEX POSITION DETERMINED FROM THE INSTALLATION MENU.

CONTROLLED DRAWING CHANGES TO THIS DRAWING REQUIRE RELEVANT AGENCY APPROVAL	SIEMENS Siemens Industry, Inc. Industry Automation Division Hauppauge, NY 11788		
	INSTALLATION, 1011HNFS SERIES DEDICATED PLASTIC BODY SENSOR		
SAP MATERIAL NO.	A5E32947129	REV AA	REV AA
ITEM NO.	A5E32947129	RS AA	RS AA
DOCUMENT NO.	1011HNFS-7	REV 004	REV 004
DATE: 9/20/2013	SCALE: NONE:	SHEET 1	OF 3

UNLESS OTHERWISE SPECIFIED: DIMENSIONS ARE IN INCHES	Holes
TOLERANCES ON- FRACTIONS DECIMAL ANGLES	Holes
± 1/64" X.XX-0.01 ±0°30' ±.003	
XXX-0.005	
DRAWN BY H.Jenkins:	

INSTALLATION NOTES - SEE DRAWING REFERENCE **A**

1. USING THE INSTALLATION MENU AND THE PROCEDURE OUTLINED IN THE FLOW COMPUTER FIELD MANUAL, CONFIRM THAT YOU HAVE THE APPROPRIATE SENSORS AND SPACER BAR (IF USED) FOR DIRECT MODE OPERATION ON THE CHOSEN PIPE.
2. SELECT MOUNTING LOCATION;
 - 2.1 CHOOSE LOCATION WHICH REMAINS FULL AT ZERO FLOW
 - 2.2 WHERE POSSIBLE LOCATE TRACK ASSTY TO PIPE DIAMETERS OR MORE FROM BEND TO INSURE FULLY DEVELOPED AND STABLE FLOW PROFILE.
 - 2.3 TO AVOID SEDIMENT BLOCKAGE OF ULTRASONIC BEAM.
3. PREPARE PIPE FOR TRACK MOUNT;
 - 3.1 REMOVE GRIT, CORROSION COATING OR HEAVY PAINT
 - 3.2 CLEAN AND DEGREASE SURFACE
 - 3.3 DO NOT MOUNT OVER FROST.
 - 3.4 CONDITION PIPE SURFACE;
 - LOCALLY SMOOTH THE PIPE SURFACE TO ACCEPT THE SENSORS. USE THE ABRASIVE PAD PROVIDED.
4. LOCATE MOUNTING FRAMES;
 - 4.1 CONSULT THE 1010 FIELD MANUAL AND USE THE INSTALLATION MENU TO SELECT THE APPROPRIATE INDEX HOLE OR SPACING (LTN) FOR YOUR APPLICATION.
 - 4.2 IF SPACER BAR IS USED:
 - 4.2.1 CLAMP ONE MOUNTING FRAME AT THE UN-NUMBERED REFERENCE POSITION OF THE SPACER BAR. BE SURE THE SPACER BAR INDEX SCREW FITS THROUGH THE HOLE IN THE SPACER BAR AND ENGAGES THE HOLE IN THE MOUNTING FRAME BLOCK.
 - 4.2.2 CLAMP THE SECOND MOUNTING FRAME TO THE SPACER BAR IN THE SAME MANNER AT THE INDEX HOLE INDICATED DURING STEP 4.1.
 - 4.2.3 HOLD THE MOUNTING FRAME/SPACER BAR ASSEMBLY ON THE PIPE AT THE SELECTED LOCATION AND TEMPORARILY SECURE IT TO THE PIPE USING STRAPS FROM THE 1012MS STRAP MOUNTING KIT. GO TO 4.4.
 - 4.3 IF MOUNTING FRAMES ARE SPACED BY MEASURING "LTN":
 - 4.3.1 TEMPORARILY SECURE ONE OF THE MOUNTING FRAMES TO THE PIPE USING STRAPS FROM THE 1012MS STRAP MOUNTING KIT.
 - 4.3.2 MEASURE ALONG THE PIPE AND TEMPORARILY SECURE THE SECOND MOUNTING FRAME TO THE PIPE SO THAT SPACING "LTN" DETERMINED IN STEP 4.1 IS MEASURED BETWEEN THE SPACING MARKS ON THE MOUNTING FRAMES. USE STRAIGHT EDGE OR OTHER MEANS TO ALIGN BOTH MOUNTING FRAMES WITH PIPE AXIS.
 - 4.4 USE THE MOUNTING GUIDE INCLUDED WITH THE 1012MS STRAP MOUNTING KIT TO TRANSFER ONE OF THE MOUNTING FRAMES TO THE OPPOSITE SIDE OF THE PIPE.
 - 4.4.1 WRAP THE MOUNTING GUIDE AROUND THE PIPE. POSITION IT SO THAT THE OVERLAPPING LENGTHS ARE EDGE-ALIGNED, MARK THE OVERLAPPING PORTION OF THE GUIDE AT THE EDGE OF THE OVERLAPPING PORTION. REMOVE THE GUIDE, MEASURE THE DISTANCE FROM THE END TO THE MARK AND MARK AGAIN HALFWAY BETWEEN.
 - 4.4.2 RE-POSITION THE GUIDE ON THE PIPE AND TAPE IN PLACE SO THAT ONE OF THE MARKS INDICATES THE CENTERLINE OF THE INSTALLED MOUNTING FRAMES AND THE MOUNTING GUIDE EDGE IS AGAINST THE END OF ONE OF THE MOUNTING FRAMES. MAKE SURE THE OVERLAPPING LENGTHS OF THE MOUNTING GUIDE ARE EDGE-ALIGNED. THIS ASSURES A DIAMETRICAL TRANSFER OF THE MOUNTING FRAME POSITION.
 - 4.4.3 LOOSEN THE MOUNTING STRAP ON THE MOUNTING FRAME WITH WHICH THE MOUNTING GUIDE HAS BEEN ALIGNED. ROTATE IT AROUND THE PIPE SURFACE UNTIL IT IS CENTERED ON THE OPPOSITE SIDE MOUNTING FRAME. USE THE STRAP FROM STEP 4.4.1. TIGHTEN THE STRAP, REMOVE THE MOUNTING GUIDE.
 - 4.5 IF THE PIPE SURFACE IS CLEAN AND SMOOTH, PROCEED TO TRANSDUCER INSTALLATION ON SHEET 3. IF PIPE SURFACE NEEDS CONDITIONING, MARK THE MOUNTING FRAME POSITION CAREFULLY, LOOSEN STRAPS AND MOVE THE MOUNTING FRAMES ASIDE. LOCALLY SMOOTH THE PIPE SURFACE IN THE MARKED AREAS USING THE ABRASIVE PAD SUPPLIED. SHUT THE MOUNTING FRAMES BACK INTO THEIR APPROPRIATE LOCATIONS AND TIGHTEN THE MOUNTING STRAPS SECURELY. ** SEE SHEET 3 FOR INSTRUCTIONS TO COMPLETE SENSOR INSTALLATION.

DIRECT MODE OPERATION

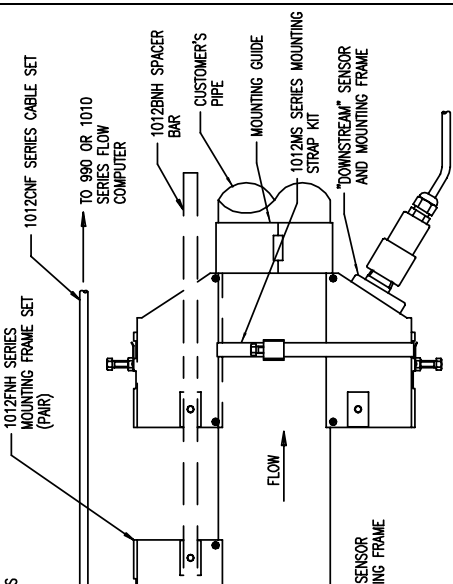

SECURING MOUNTING FRAMES TO THE PIPE SURFACE

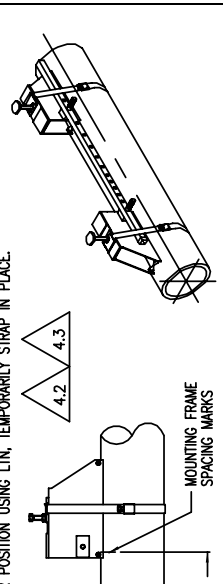

USE THE MOUNTING GUIDE TO TRANSFER ONE OF THE MOUNTING FRAMES TO THE OPPOSITE SIDE OF THE PIPE.

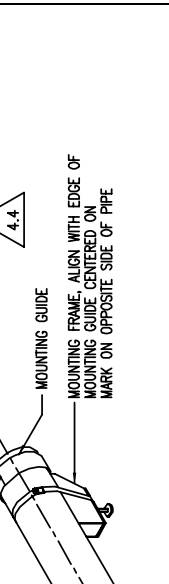

IF NECESSARY, USE THE ABRASIVE PAD SUPPLIED TO PRODUCE A SMOOTH FINISH ON THE PIPE AT THE SENSOR MOUNTING POSITIONS.



PREFERRED MOUNTING PLANE

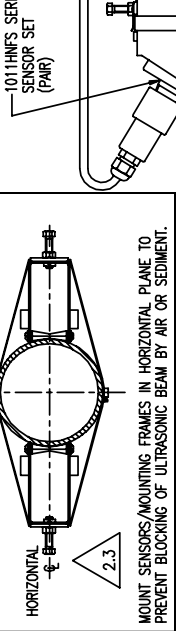

USING THE SPACER BAR TO SET SENSOR MOUNTING FRAME SPACING

USING THE INSTALLATION MENU, AS OUTLINED IN THE FLOW COMPUTER FIELD MANUAL, DETERMINE THE SPACING INDEX NUMBER FOR THE SELECTED APPLICATION. USE THE SPACER BAR INDEX SCREW TO SECURE THE SPACER BAR TO ONE OF THE MOUNTING FRAMES AT THE UN-NUMBERED REFERENCE POSITION.

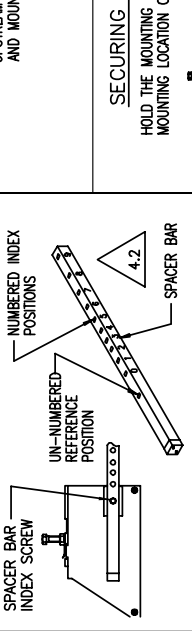

SECURE THE SECOND MOUNTING FRAME TO THE SPACER BAR AT THE NUMBERED INDEX POSITION DETERMINED FROM THE INSTALLATION MENU.

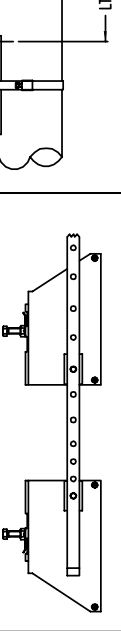

WRAP MOUNTING GUIDE AROUND PIPE AND MARK AT OVERLAPPING EDGE UNWRAP GUIDE, MEASURE DISTANCE "L" FROM EDGE TO MARK, MARK AGAIN AT 1/2 "L". RE-INSTALL THE MOUNTING GUIDE, TAPE IN PLACE WITH BOTH MARKS VISIBLE. ALIGN ONE MARK WITH THE CENTER LINE OF THE MOUNTING FRAMES.

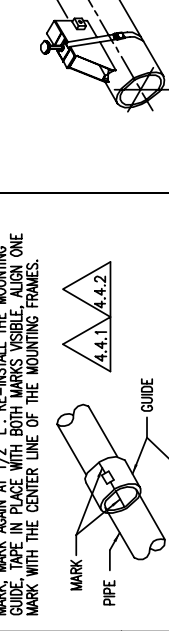

ALIGN OVERLAPPING EDGES

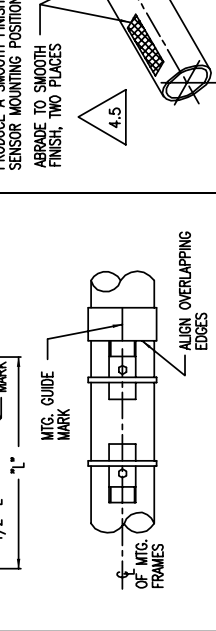

CONTROLLED DRAWING CHANGES TO THIS DRAWING REQUIRE RELEVANT AGENCY APPROVAL		SIEMENS Siemens Industry, Inc. Industry Automation Division Hauppauge, NY 11788	
INSTALLATION, 1011HNFS SERIES DEDICATED PLASTIC BODY SENSOR			
SAP MATERIAL NO.	A5E32947129	REV AA	REV AA
ITEM NO.	A5E32947129	RS AA	RS AA
DOCUMENT NO.	1011HNFS-7	REV 004	REV 004
DATE: 9/30/2013	SCALE: NONE:	SHEET 2	OF 3

UNLESS OTHERWISE SPECIFIED: DIMENSIONS ARE IN INCHES	Holes
TOLERANCES ON- FRACTIONS DECIMAL ANGLES	Holes
±.1/64" XX.00.01 ±0°30' ±.003	XXX.00.005

4 3 2 1

MATING 1012CNF SERIES SENSOR CABLES WITH 1011HNF SERIES SENSORS

- REMOVE PROTECTIVE CAPS.
- SEE APPROPRIATE CABLE ASSEMBLY DRAWING FOR 'F' CONNECTOR, NPT ADAPTER AND GLAND ASSEMBLY DETAIL.
- MATE 'F' CONNECTORS, CABLES TO SENSOR.
- FOR BEST WEATHER SEAL, WRAP TEFLON PIPE TAPE (NOT SUPPLIED) AROUND MALE NPT THREADS ON SENSOR HOUSING.
- SCREW NPT ADAPTER TO SENSOR HOUSING (HAND TIGHT IS SUFFICIENT).
- TIGHTEN GLAND BODY WITH NPT ADAPTER AND SECURE CABLE BY TIGHTENING GLAND TOP NUT. (HAND TIGHT IS SUFFICIENT).

SENSOR SIZE A & B

SENSOR SIZE C & D

SENSOR SIZE A & B

SENSOR SIZE C & D

INSTALLATION NOTES - CONT'D FROM SHT. 1 OR SHT. 2

- MAKE CABLE CONNECTIONS AT FLOW COMPUTER IN ACCORDANCE WITH APPROPRIATE FLOW COMPUTER INSTALLATION DRAWING AND 1010 FIELD MANUAL.
- SEE DRAWINGS 1012FNH-8 AND 1011HNF-8 FOR MOUNTING FRAME AND SENSOR OUTLINE DIMENSIONS.

INSTALLING SENSORS IN MOUNTING FRAMES

APPLY A THIN BAND OF COUPLANT TO THE EMITTING SURFACE OF THE SENSORS. SLIP THE SENSORS INTO THE MOUNTING FRAMES, SEATING THEM SQUARELY ON THE PIPE SURFACE. PUSH FORWARD INTO THE FRAMES AGAINST THE FRONT SPACER. LOCATE CLAMPING SCREW IN PROPER POSITION. TIGHTEN THE SENSOR CLAMPING SCREW, FIRMLY SEATING THE SENSORS ON THE PIPE SURFACE. SECURE THE CLAMPING SCREW WITH LOCK NUT.

SENSOR SIZE A & B

SENSOR SIZE C & D

**SEE DRAWING 1012THP-7 FOR INSTALLATION USING 1012THP SERIES MOUNTING TRACKS.

USE OF FLEXIBLE CONDUIT WITH SENSORS

THE SENSOR WIRING HOUSING HAS INTEGRAL 1/2" N.P.T. THREADS TO ACCEPT A CONDUIT COUPLING IF FLEXIBLE CONDUIT IS USED. MAKE CONNECTION AS SHOWN, THEN PASS COUPLING AND CONDUIT OVER THE CABLE, SECURE TO THE SENSOR WIRING HOUSING.

1/2" FLEXIBLE CONDUIT AND FITTING (BY CUSTOMER)

1/2" N.P.T. COUPLING (BY CUSTOMER)

1/2" FLEXIBLE CONDUIT AND FITTING (BY CUSTOMER)

1/2" N.P.T. COUPLING (BY CUSTOMER)

CONTROLLED DRAWING
 CHANGES TO THIS DRAWING REQUIRE RELEVANT AGENCY APPROVAL

SIEMENS
 Siemens Industry, Inc.
 Industry Automation Division
 Hauppauge, NY 11788

INSTALLATION, 1011HNF SERIES DEDICATED PLASTIC BODY SENSOR

SAP MATERIAL NO.	A5E32947129	REV AA
ITEM NO.	A5E32947129	RS AA
DOCUMENT NO.	1011HNF-7	REV 004
DATE: 9/30/2013	SCALE: NONE	SHEET 3 OF 3

UNLESS OTHERWISE SPECIFIED:
 DIMENSIONS ARE IN INCHES

FRACTIONS	DECIMAL	ANGLES	HOLES
± 1/64"	XX.XX,01	± 0°/30'	± .003
	XX.XX,±0.005		

DRAWN BY H.Jenkins:

4 3 2 1

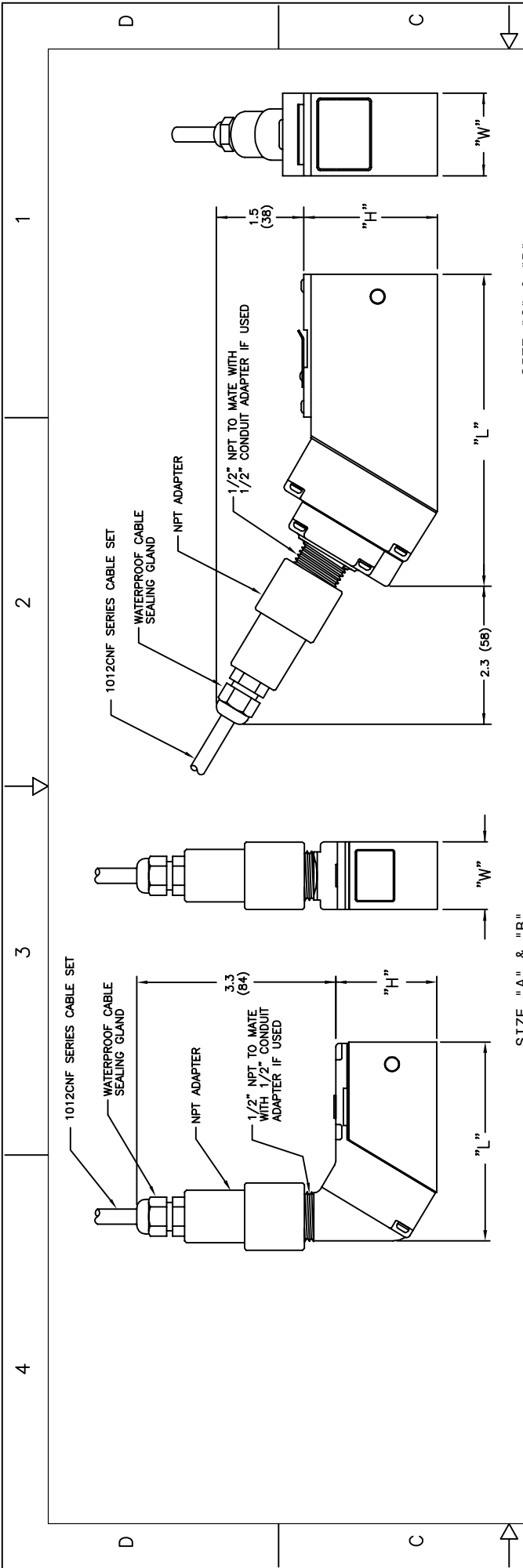

SIZE "C" & "D"

SIZE "A" & "B"

NOTES :

1. SENSORS ARE SUPPLIED IN MATCHED PAIRS. BOTH SENSORS OF A PAIR HAVE THE SAME SERIAL NUMBER.
2. SEE THE APPROPRIATE SENSOR INSTALLATION DRAWING FOR COMPLETE INSTALLED DIMENSIONS.
3. SENSOR PART NUMBER VARIES WITH OPERATING FREQUENCY AND APPLICATION TEMPERATURE.

SENSOR PART NUMBER	L	W	H	NET WT. (PAIR)
1011HNFS-A1/2/3	2.2 (56)	1.1 (28)	1.7 (43)	0.5# (0.23kg)
1011GCHNFS-A1/2/3	3.3 (84)	1.1 (28)	1.7 (43)	0.8# (0.36kg)
1011HNFS-B1/2/3	2.6 (66)	1.1 (28)	1.7 (43)	0.7# (0.32kg)
1011GCHNFS-B1	5.0 (127)	1.3 (33)	2.2 (56)	1.9# (0.86kg)
1011HNFS-C1/2	4.1 (104)	2.0 (51)	3.3 (84)	1.4# (0.64kg)
1011GCHNFS-C2	7.5 (191)	2.0 (51)	3.3 (84)	4.9# (2.2kg)
1011HNFS-D1/2/3/4	6.8 (173)	2.0 (51)	3.3 (84)	4.2# (1.9kg)
1011GCHNFS-D2/4				
1011GCHNFS-D1/3				

* SEE NOTE 3

SIEMENS
Siemens Industry, Inc.
Industry Automation Division
Hauptpauze, NY 11788

OUTLINE DIMENSIONS
1011HNF SERIES DEDICATED PLASTIC BODY SENSORS

SAP MATERIAL NO.	REV.
ITEM NO.	RS
DOCUMENT NO.	1011HNFS-8
DATE: 9/30/2013	SCALE: NONE
SHEET	1 OF 1

UNLESS OTHERWISE SPECIFIED:
DIMENSIONS ARE IN INCHES
TOLERANCES ON: ANGLES HOLES
FRACTIONS DECIMALS ±.003 ±.003 ±.003

DRAWN BY H.Jehliene

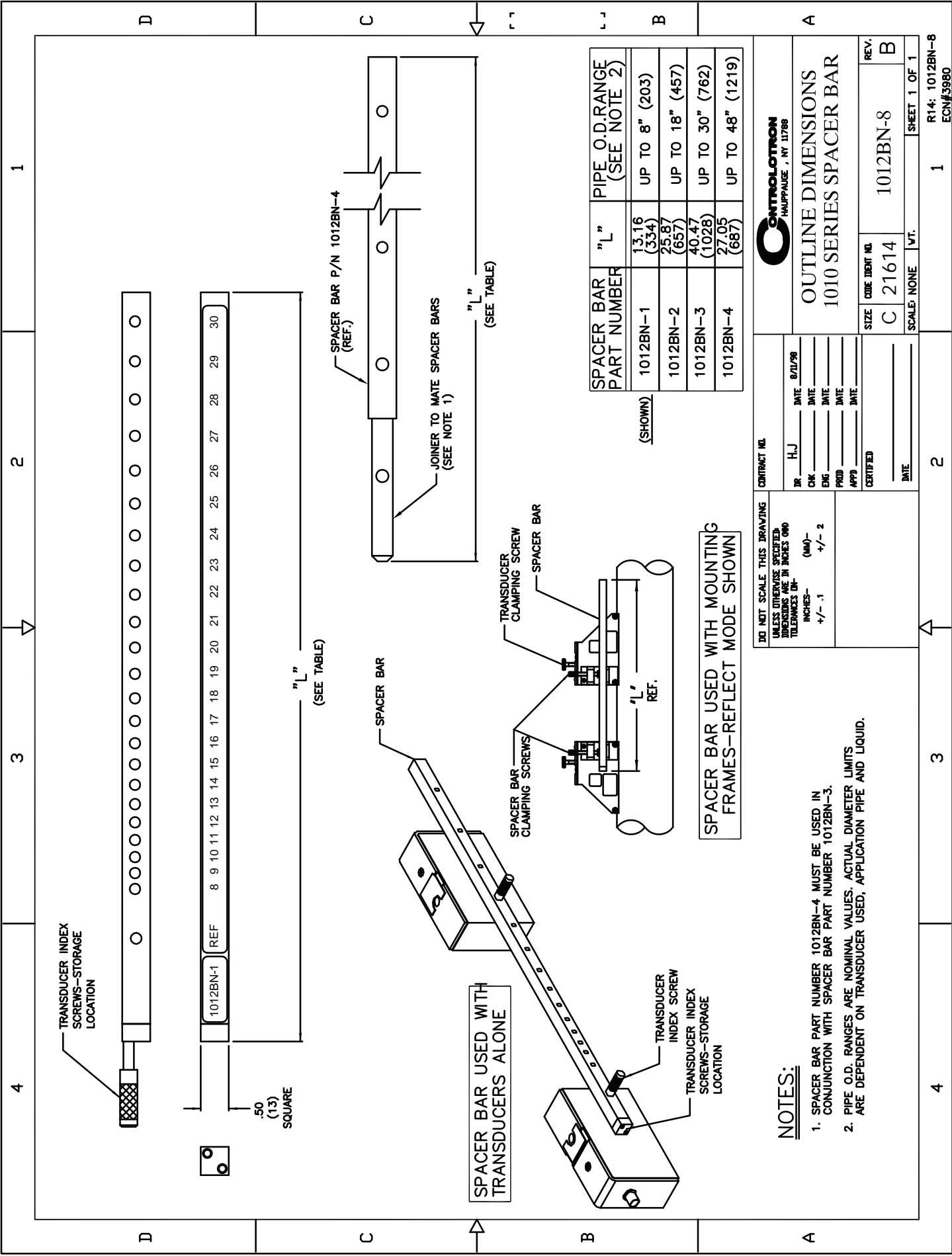

CONTROLTRON
HAUPPAUGE, NY 11788

OUTLINE DIMENSIONS
1010 SERIES SPACER BAR

SIZE: C 21614
CODE IDENT NO.: 1012BN-8
SCALE: NONE
REV. B

CONTRACT NO. _____
DATE: 8/11/98

DR: H.J.
CHK: _____
ENG: _____
PRD: _____
APPD: _____

CERTIFIED: _____
DATE: _____

DO NOT SCALE THIS DRAWING
UNLESS OTHERWISE SPECIFIED
DIMENSIONS ARE IN INCHES UN-
LESS OTHERWISE SPECIFIED
TOLERANCES UN-
INCHES: +/- .1 (MM): +/- .2

NOTES:

1. SPACER BAR PART NUMBER 1012BN-4 MUST BE USED IN CONJUNCTION WITH SPACER BAR PART NUMBER 1012BN-3.
2. PIPE O.D. RANGES ARE NOMINAL VALUES. ACTUAL DIAMETER LIMITS ARE DEPENDENT ON TRANSDUCER USED, APPLICATION PIPE AND LIQUID.

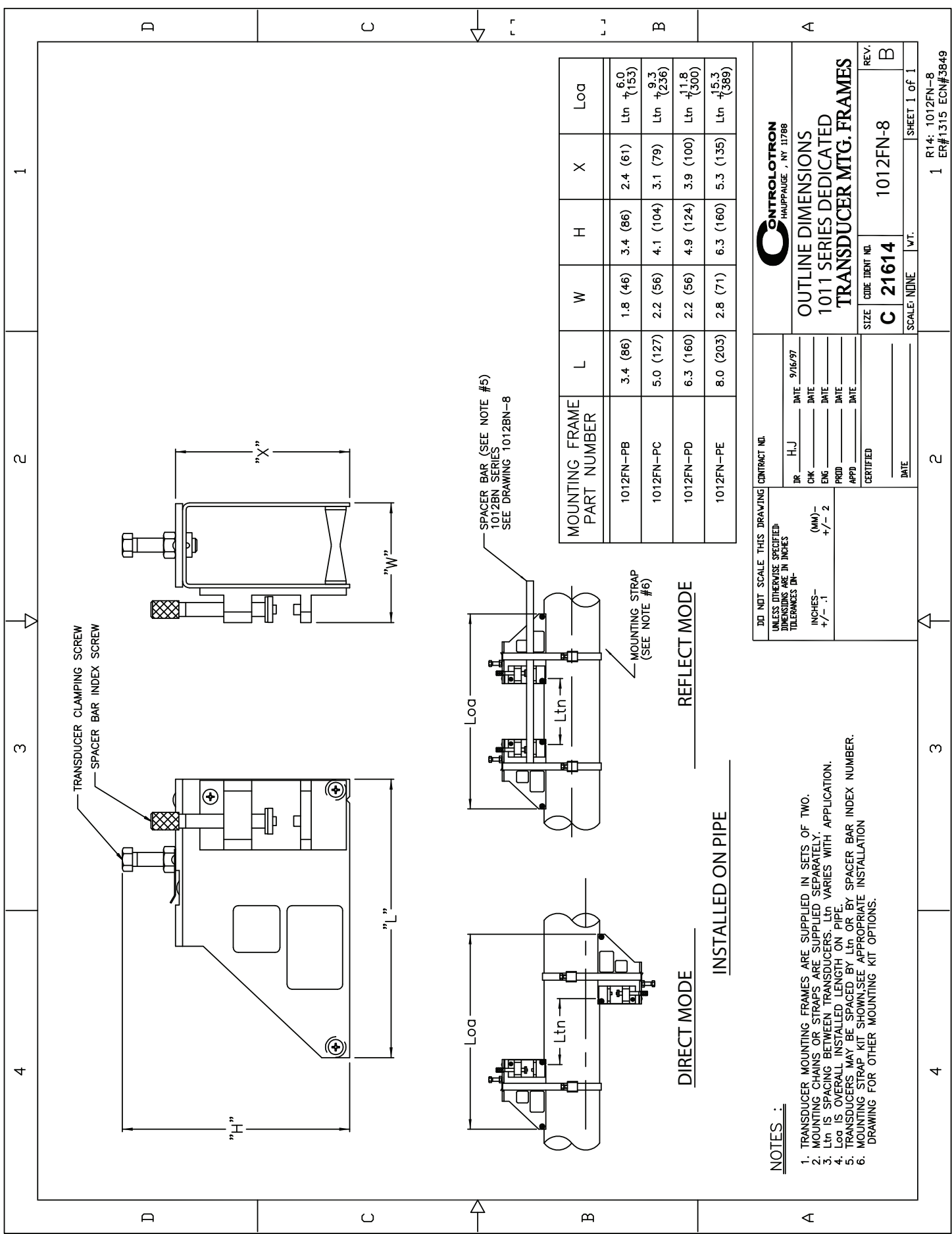

MOUNTING FRAME PART NUMBER	L	W	H	X	Loa
1012FN-PB	3.4 (86)	1.8 (46)	3.4 (86)	2.4 (61)	6.0 Ltn +1.53
1012FN-PC	5.0 (127)	2.2 (56)	4.1 (104)	3.1 (79)	9.3 Ltn +2.36
1012FN-PD	6.3 (160)	2.2 (56)	4.9 (124)	3.9 (100)	11.8 Ltn +3.00
1012FN-PE	8.0 (203)	2.8 (71)	6.3 (160)	5.3 (135)	15.3 Ltn +3.89

CONTROLTRON
HAUPPAUGE, NY 11788

OUTLINE DIMENSIONS
1011 SERIES DEDICATED
TRANSDUCER MTG. FRAMES

SIZE CODE IDENT NO. **C 21614** 1012FN-8 REV. **B**

SCALE: NONE WT. SHEET 1 OF 1

DO NOT SCALE THIS DRAWING CONTRACT NO. _____

UNLESS OTHERWISE SPECIFIED: DIMENSIONS IN INCHES TOLERANCES: DR _____ DATE 9/16/97

DR H-J _____ DATE _____

CHK _____ DATE _____

ENG _____ DATE _____

PRD _____ DATE _____

APPD _____ DATE _____

CERTIFIED _____ DATE _____

(MM) - +/-.2

INCHES - +/-.1

- NOTES :**
1. TRANSDUCER MOUNTING FRAMES ARE SUPPLIED IN SETS OF TWO.
 2. MOUNTING CHAINS OR STRAPS ARE SUPPLIED SEPARATELY.
 3. Ltn IS SPACING BETWEEN TRANSDUCERS. Ltn VARIES WITH APPLICATION.
 4. Loa IS OVERALL INSTALLED LENGTH ON PIPE.
 5. TRANSDUCERS MAY BE SPACED BY Ltn OR BY SPACER BAR INDEX NUMBER.
 6. MOUNTING STRAP KIT SHOWN; SEE APPROPRIATE INSTALLATION DRAWING FOR OTHER MOUNTING KIT OPTIONS.

INSTALLED ON PIPE

DIRECT MODE

REFLECT MODE

INSTALLATION PROCEDURE

MOUNTING STRAP KITS ARE TO FASTEN TRANSDUCERS OR MOUNTING FRAMES TO THE PIPE.

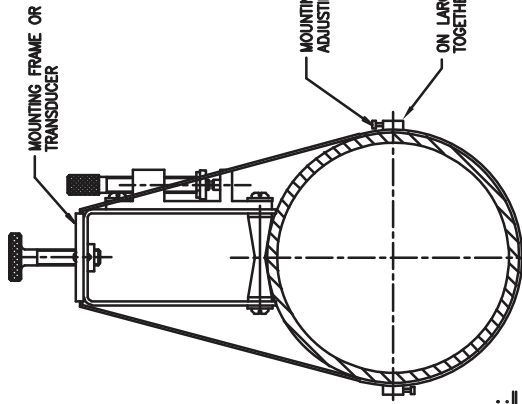

NOTES:

1. WRAP THE MOUNTING STRAP AROUND THE PIPE, PULL TAUT AND ENGAGE THE END OF MOUNTING STRAP WITH THE MOUNTING STRAP ADJUSTING SCREW.
2. TIGHTEN THE ADJUSTING SCREW TO SECURE THE ASSEMBLY TO THE PIPE.
3. TO SURROUND LARGER PIPES, LINK MOUNTING STRAP SECTIONS TOGETHER AS SHOWN.

STRAP MTC. KIT PART No.	PIPE DIA.	BAND SIZE (QTY)	SPACING GUIDE P/N (DESCRIPTION)	KIT NET WT.
1012MS-1A	2"-7"	#88 (2) #128 (2)	1012-145-1A (2" x 26")	
1012MS-1	2"-13"	#88 (2) #152 (2)	1012-145-1 (2" x 45")	
1012MS-2	13"-24"	#188 (2) #280 (2)	1012-145-2 (4" x 81")	
1012MS-3	24"-48"	#152 (4) #312 (4)	1012-145-3 (4" x 155")	
1012MS-4	48"-60"	36' OF 1/2" BAND AND FASTENER	1012-145-4 (6" x 196")	
1012MS-5	60"-84"	46' OF 1/2" BAND AND FASTENER	NOT SUPPLIED	
1012MS-6	84"-120"	65' OF 1/2" BAND AND FASTENER	NOT SUPPLIED	
1012MS-7	120"-216"	116' OF 1/2" BAND AND FASTENER	NOT SUPPLIED	
1012MS-8	216"-360"	190' OF 1/2" BAND AND FASTENER	NOT SUPPLIED	

TRANSDUCERS INSTALLED WITH SPACER BARS ONLY

SPRING CLIP (NOT PRESENT ON SOME TRANSDUCER MODELS)

SPACER BAR

1011 SERIES TRANSDUCER

CUSTOMER'S PIPE

MOUNTING STRAP

1012 SERIES MOUNTING FRAME

SPRING CLIP (NOT PRESENT ON SOME MTC. FRAME MODELS)

SPACER BAR

WHEN MOUNTING ON SMALLER PIPE SIZES, USE STRAP GUIDE ACCESSORY AS SHOWN.

TRANSDUCERS INSTALLED WITH MOUNTING FRAMES

TRANSDUCER CLAMPING

CUSTOMER'S PIPE

MOUNTING STRAP

ON LARGER PIPES, ADDITIONAL STRAPS MAY BE INSTALLED FOR A MORE SECURE MOUNT

SPACING GUIDE (SEE TABLE)

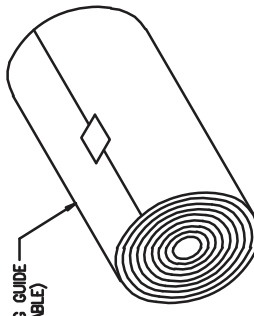

DO NOT SCALE THIS DRAWING UNLESS OTHERWISE SPECIFIED DIMENSIONS ARE IN INCHES UNLESS OTHERWISE SPECIFIED

CONTRACT NO.

DATE

DATE



INSTALLATION / OUTLINE ADJUSTABLE MOUNTING STRAP

SIZE	CODE IDENT. NO.	REV.
C	21614	1012MS-8
SCALE: NONE	VT.	SHEET 1 OF 2

BAND LENGTH TABLE	
PIPE DIA.	LENGTH TO CUT ON MARK
48"	167-5/16"
50"	173-9/16"
52"	177-7/8"
54"	180-3/16"
56"	186-7/16"
58"	188-3/4"
60"	195"
84"	267-3/8"
120"	380-1/2"

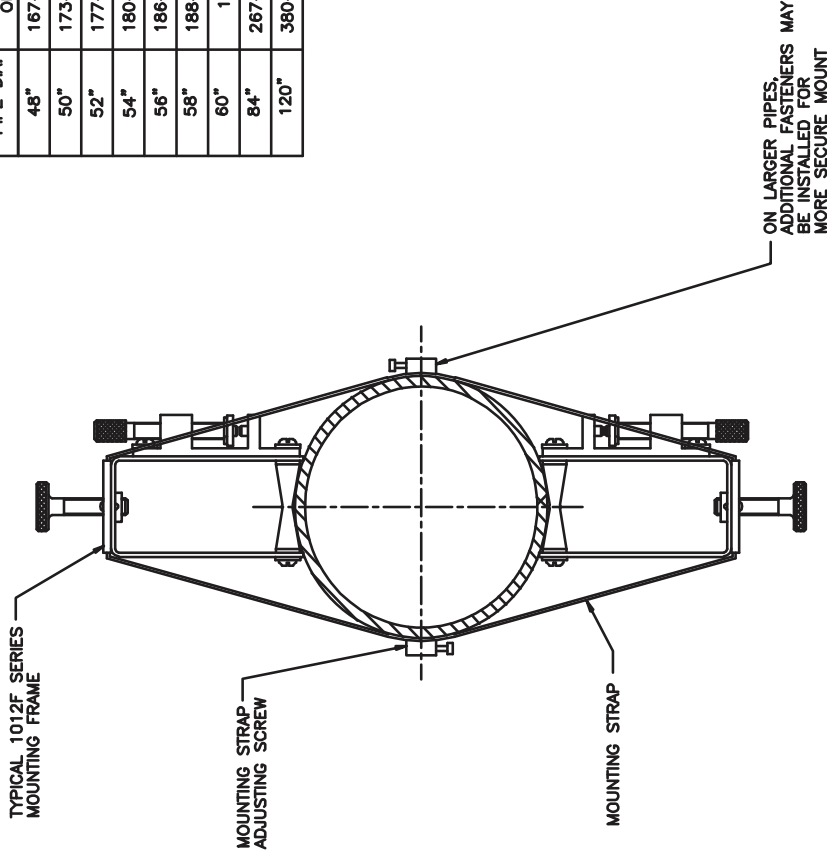

NOTES:

- BAND LENGTHS ARE APPROXIMATE AND CALCULATED FOR USE OF SIZE "D" OR "E" 1011 TRANSDUCERS.

STEP - 1
 DETERMINE PROPER BAND LENGTH ONE OF TWO WAYS:
 A) IF DIAMETER IS KNOWN, REFER TO BAND LENGTH TABLE OR CALCULATE MAXIMUM BAND LENGTH 3.14 x DIA. + 18", TRIM TO FIT WHEN INSTALLING.
 B) IF DIAMETER IS NOT KNOWN, MEASURE CIRCUMFERENCE WITH STRING, TWINE, etc., AND ADD 18" (TO ENCIRCLE FRAMES). THIS DIMENSION IS APPROXIMATE, TRIM BAND TO FIT WHEN INSTALLING.

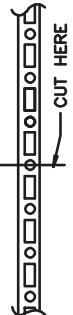
STEP - 2
 MEASURE BAND TO PROPER LENGTH AND CUT THROUGH CENTER OF NEAREST ROUND HOLE WITH SHEARS, SNIPS, HACKSAW etc.

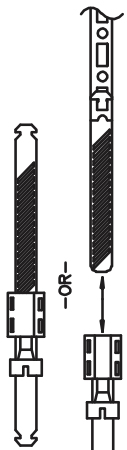
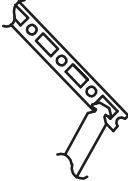
STEP - 3
 EITHER MATE FASTENER HALVES AND THEN LINK TO STRAP ALREADY IN PLACE AROUND PIPE, OR LINK FASTENER HALVES INDEPENDENTLY TO STRAP ENDS (HOLD IN PLACE WITH TAPE IF NECESSARY) AND ENGAGE FASTENER AFTER WRAPPING STRAP AROUND PIPE.

 -OR-

 DIAGONALLY INSERT FASTENER END INTO RECTANGULAR SLOTS TO LINK WITH STRAP (INSERT AT LOCATION BEST SUITED FOR TIGHT FIT).

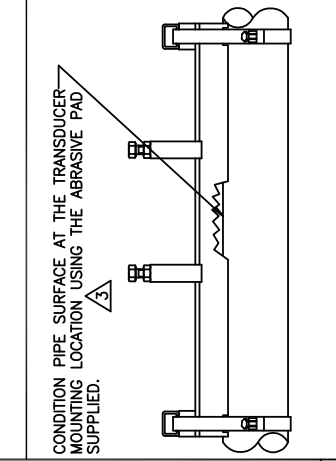
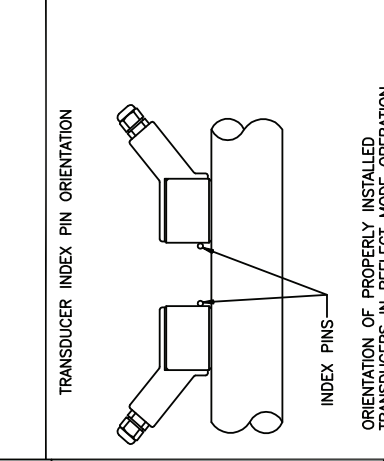
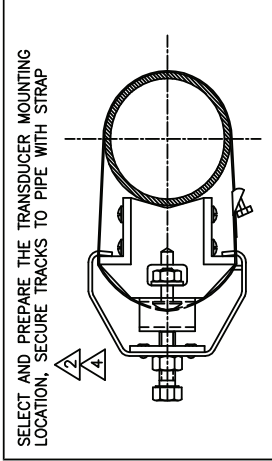
STEP - 4
 USING STRAPS MADE TO SIZE REQUIRED, INSTALL MOUNTING TRACKS AND TRANSDUCERS IN ACCORDANCE WITH APPROPRIATE INSTALLATION DRAWING FOR SPECIFIC TRACK ASSEMBLIES.

 CONTROLOTRON HAUPPAUGE, NY 11768	
INSTALLATION / OUTLINE ADJUSTABLE MOUNTING STRAP	
SIZE C 21614	REV. F
CODE IDENT NO. 1012MS - 8	SHEET 2 OF 2
SCALE: NONE / VT.	R14: 1012MS-8 sht.2 rev.F ECN#3974, ECN#4022
CONTRACT NO. DR: HJJ DATE: 2/14/97 CHK: DATE: ENG: DATE: PRD: DATE: APPD: DATE: CERTIFIED: DATE:	DO NOT SCALE THIS DRAWING UNLESS OTHERWISE SPECIFIED DIMENSIONS IN INCHES UNP TOLERANCES UN- INCHES (MM) ± .1 ± .2

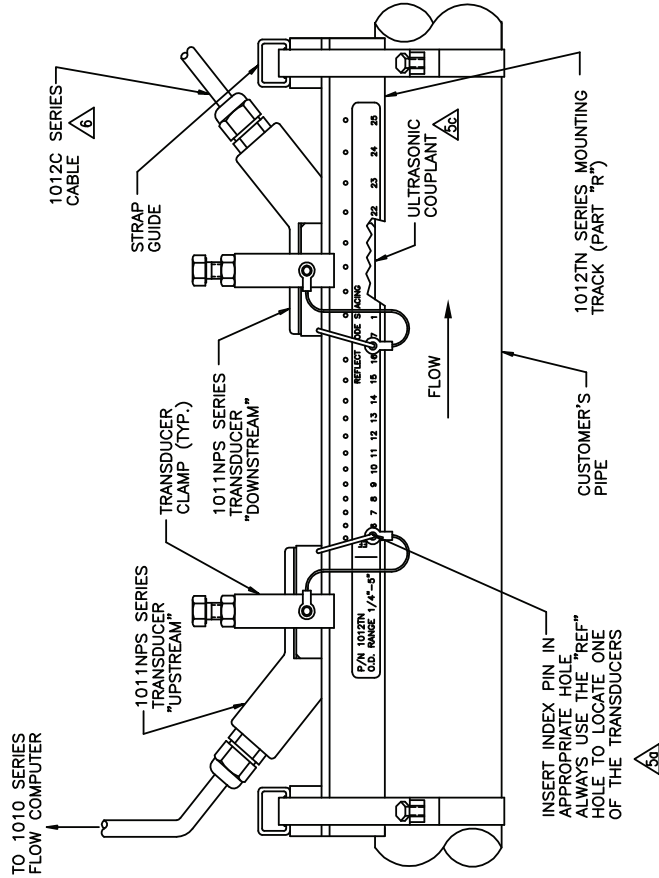

REFLECT MODE INSTALLATION
1011N UNIVERSAL TRANSDUCER AND TRACK



- INSTALLATION PROCEDURE - SEE DRAWING REFERENCES**
1. USING THE INSTALLATION MENU PROCEDURES PRESENTED IN THE 1010 FIELD MANUAL, CONFIRM THAT YOU HAVE THE APPROPRIATE TRANSDUCERS AND TRACK FOR REFLECT MODE OPERATION ON THE CHOSEN PIPE.
 2. SELECT MOUNTING LOCATION:
 - a) CHOOSE LOCATION WHICH REMAINS FULL AT ZERO FLOW.
 - b) WHERE POSSIBLE, LOCATE TRACK ASSY. TEN (10) PIPE DIAMETERS OR MORE FROM BEND TO ENSURE FULLY DEVELOPED AND STABLE FLOW PROFILE.
 - c) ON HORIZONTAL PIPE, SELECT HORIZONTAL PLANE, IF POSSIBLE; TO AVOID SEDIMENT BLOCKAGE OF TRANSDUCER SIGNAL.
 3. PREPARE PIPE FOR TRACK MOUNT:
 - a) REMOVE GRIT, CORROSION, COATING OR HEAVY PAINT
 - b) CLEAN AND DEGREASE SURFACE
 - c) DO NOT MOUNT OVER FROST.
 - d) CONDITION PIPE SURFACE:
 - i) LOCALLY SMOOTH THE PIPE SURFACE TO ACCEPT THE TRANSDUCERS. USE THE ABRASIVE PAD PROVIDED.
 4. MOUNT TRACK ON PIPE:
 - a) PLACE TRACK RAIL ASSY (ASSY WITH STRAP) AGAINST PIPE WHILE HOLDING TRACK, WRAP STRAP AROUND PIPE AND TIGHTEN.
 - b) ROTATE ASSY AROUND THE PIPE FOR PROPER POSITIONING. ONCE THAT HAS BEEN ACHIEVED, SECURE THE TRACK RAIL ASSY TO THE PIPE WITH THE STRAP.
 5. LOCATE TRANSDUCERS:
 - a) CONSULTING THE 1010 FIELD MANUAL, USE THE INSTALLATION MENU TO DETERMINE THE APPROPRIATE INDEX HOLES FOR YOUR APPLICATION AND INSERT PINS.
 - b) APPLY A THIN BAND OF THE ULTRASONIC COUPLANT PROVIDED TO THE BASE OF EACH TRANSDUCER.
 - c) INSERT TRANSDUCERS INTO TRACK AS SHOWN, BANKING AGAINST INDEX PINS. SECURE TRANSDUCERS WITH CLAMPS.
 6. MAKE TRANSDUCER CABLE CONNECTIONS IN ACCORDANCE WITH THE APPROPRIATE FLOW COMPUTER INSTALLATION DRAWING AND 1010 FIELD MANUAL.
 7. SEE DRAWING 1012TN-8 AND 1011NPS-8 FOR TRACK AND TRANSDUCER OUTLINE DIMENSIONS.

CONTROLTRON
HAUPPAUGE, NY 11788

INSTALLATION DRAWING
1010 SERIES TRANSDUCERS
AND MOUNTING TRACKS

CONTRACT NO.	DATE	6/10/98
DR H-J	DATE	
CHK	DATE	
ENG	DATE	
PRD	DATE	
APPD	DATE	
CERTIFIED	DATE	

DO NOT SCALE THIS DRAWING
UNLESS OTHERWISE SPECIFIED,
DIMENSIONS ARE IN INCHES (MM)
TOLERANCES IN-
INCHES
+/- .1
(MM)
+/- .2

SIZE	CODE IDENT NO.	REV.
C 21614	1012TN-7	A

SCALE: NONE WT. SHEET 1 OF 2

1 R14: 1012TN-7A rev.A

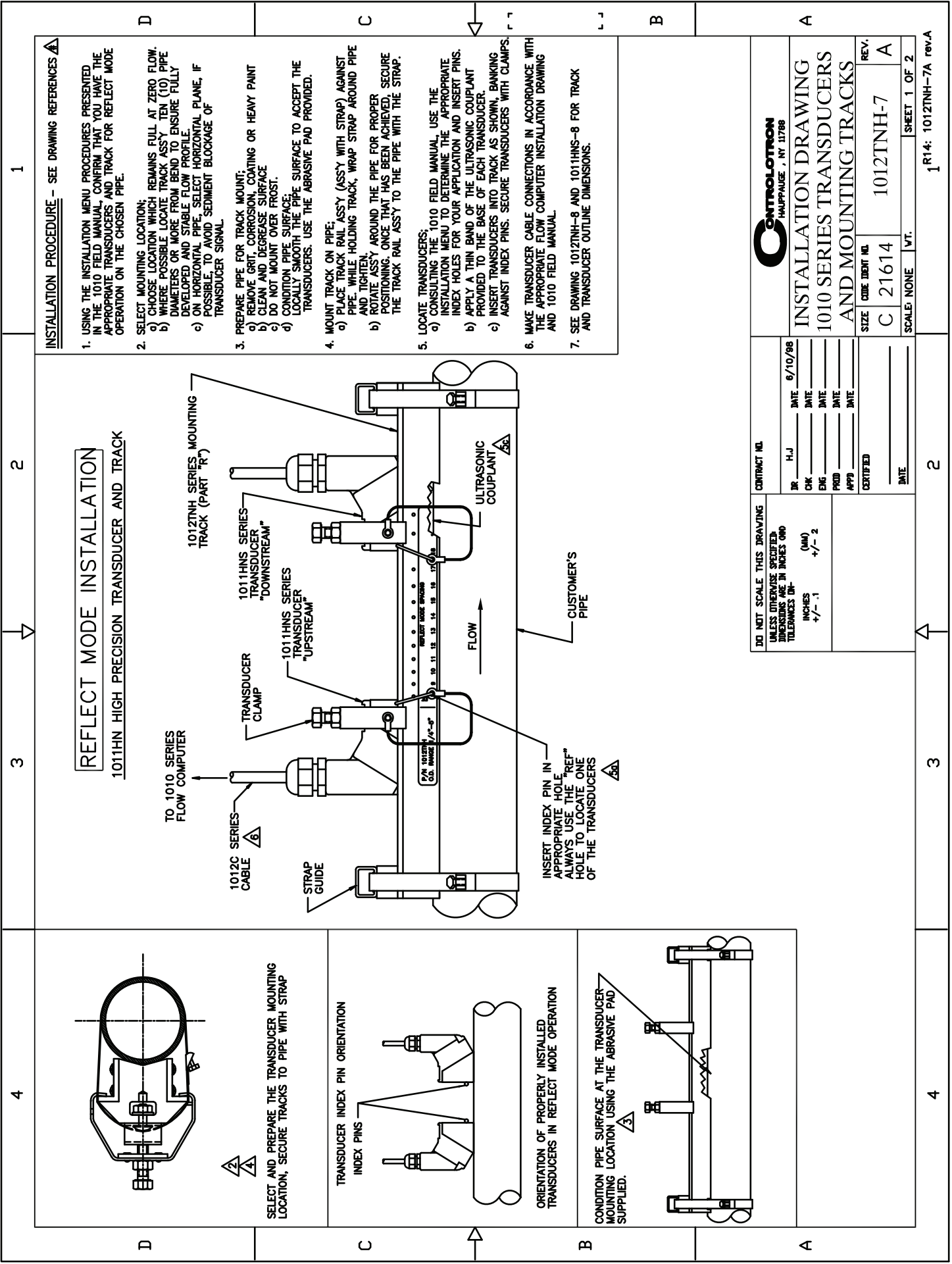

REFLECT MODE INSTALLATION

1011HN HIGH PRECISION TRANSDUCER AND TRACK

INSTALLATION PROCEDURE - SEE DRAWING REFERENCES

1. USING THE INSTALLATION MENU PROCEDURES PRESENTED IN THE 1010 FIELD MANUAL, CONFIRM THAT YOU HAVE THE APPROPRIATE TRANSDUCERS AND TRACK FOR REFLECT MODE OPERATION ON THE CHOSEN PIPE.
2. SELECT MOUNTING LOCATION:
 - a) CHOOSE LOCATION WHICH REMAINS FULL AT ZERO FLOW. WHERE POSSIBLE, LOCATE TRACK ASSY TEN (10) PIPE DIAMETERS OR MORE FROM BEND TO ENSURE FULLY DEVELOPED AND STABLE FLOW PROFILE.
 - b) ON HORIZONTAL PIPE, SELECT HORIZONTAL PLANE, IF POSSIBLE, TO AVOID SEDIMENT BLOCKAGE OF TRANSDUCER SIGNAL.
3. PREPARE PIPE FOR TRACK MOUNT:
 - a) REMOVE GRIT, CORROSION, COATING OR HEAVY PAINT
 - b) CLEAN AND DEGREASE SURFACE
 - c) DO NOT MOUNT OVER FROST.
 - d) CONDITION PIPE SURFACE: LOCALLY SMOOTH THE PIPE SURFACE TO ACCEPT THE TRANSDUCERS. USE THE ABRASIVE PAD PROVIDED.
4. MOUNT TRACK ON PIPE:
 - a) PLACE TRACK RAIL ASSY (ASSY WITH STRAP) AGAINST PIPE. WHILE HOLDING TRACK, WRAP STRAP AROUND PIPE AND TIGHTEN.
 - b) ROTATE ASSY AROUND THE PIPE FOR PROPER POSITIONING. ONCE THAT HAS BEEN ACHIEVED, SECURE THE TRACK RAIL ASSY TO THE PIPE WITH THE STRAP.
5. LOCATE TRANSDUCERS:
 - a) CONSULTING THE 1010 FIELD MANUAL, USE THE INSTALLATION MENU TO DETERMINE THE APPROPRIATE INDEX HOLES FOR YOUR APPLICATION AND INSERT PINS.
 - b) APPLY A THIN BAND OF THE ULTRASONIC COUPLANT PROVIDED TO THE BASE OF EACH TRANSDUCER.
 - c) INSERT TRANSDUCERS INTO TRACK AS SHOWN, BANKING AGAINST INDEX PINS. SECURE TRANSDUCERS WITH CLAMPS.
6. MAKE TRANSDUCER CABLE CONNECTIONS IN ACCORDANCE WITH THE APPROPRIATE FLOW COMPUTER INSTALLATION DRAWING AND 1010 FIELD MANUAL.
7. SEE DRAWING 1012TNH-8 AND 1011HNS-8 FOR TRACK AND TRANSDUCER OUTLINE DIMENSIONS.

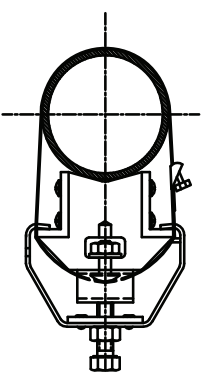

SELECT AND PREPARE THE TRANSDUCER MOUNTING LOCATION, SECURE TRACKS TO PIPE WITH STRAP

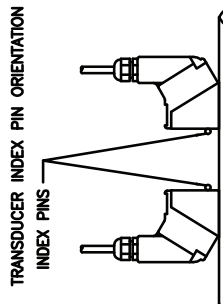

TRANSDUCER INDEX PIN ORIENTATION

ORIENTATION OF PROPERLY INSTALLED TRANSDUCERS IN REFLECT MODE OPERATION

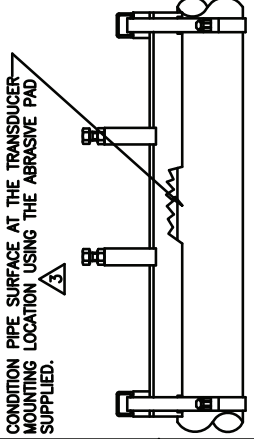

CONDITION PIPE SURFACE AT THE TRANSDUCER MOUNTING LOCATION USING THE ABRASIVE PAD SUPPLIED.

CONTROLTRON HAUPPAUGE, NY 11788	
INSTALLATION DRAWING 1010 SERIES TRANSDUCERS AND MOUNTING TRACKS	
SIZE: C CODE IDENT NO.: 21614 SCALE: NONE	REV.: A 1012TNH-7 SHEET 1 OF 2
CONTRACT NO. DR: H-J CHK: _____ ENG: _____ PRD: _____ APPD: _____ CERTIFIED: _____ DATE: _____	DATE: 6/10/98 DATE: _____ DATE: _____ DATE: _____ DATE: _____
DO NOT SCALE THIS DRAWING UNLESS OTHERWISE SPECIFIED DIMENSIONS ARE IN INCHES AND TOLERANCES UNLESS OTHERWISE SPECIFIED INCHES +/-.1 (MM) +/-.2	2

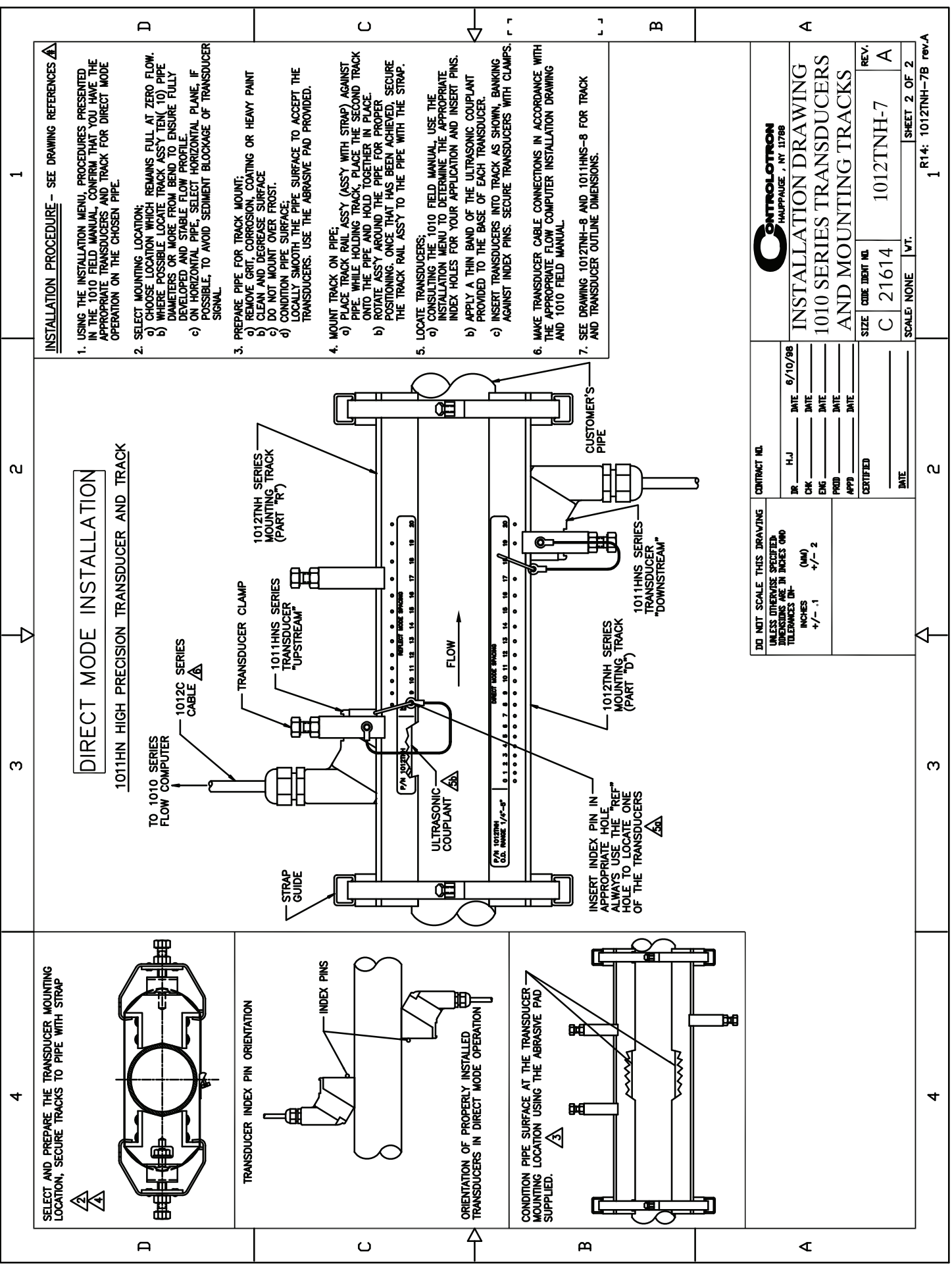

SELECT AND PREPARE THE TRANSDUCER MOUNTING LOCATION, SECURE TRACKS TO PIPE WITH STRAP

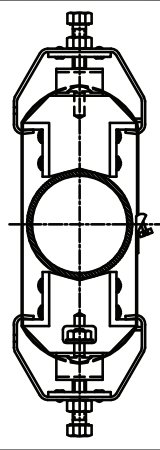

TRANSDUCER INDEX PIN ORIENTATION

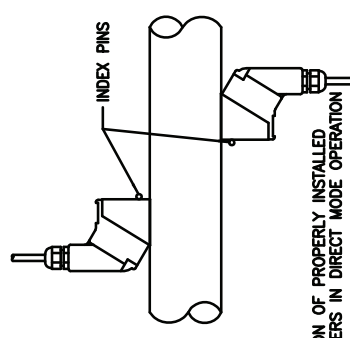

CONDITION PIPE SURFACE AT THE TRANSDUCER MOUNTING LOCATION USING THE ABRASIVE PAD SUPPLIED.

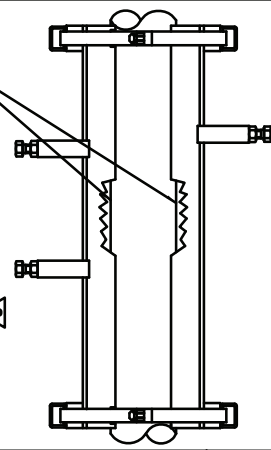

DIRECT MODE INSTALLATION

1011HN HIGH PRECISION TRANSDUCER AND TRACK

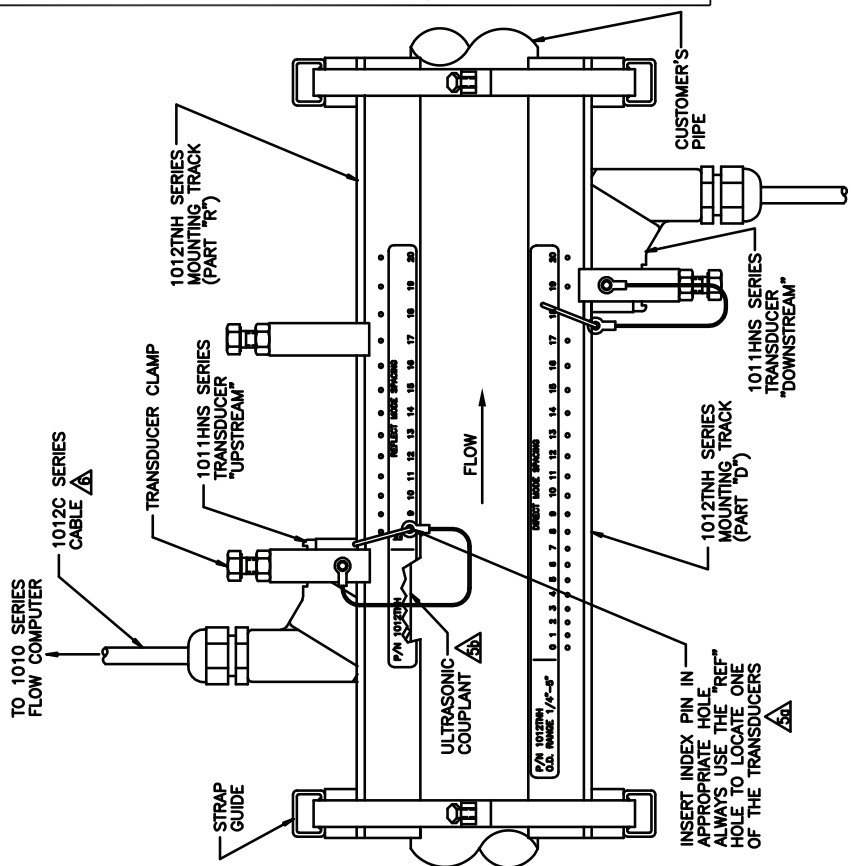

INSTALLATION PROCEDURE - SEE DRAWING REFERENCES

1. USING THE INSTALLATION MENU, PROCEDURES PRESENTED IN THE 1010 FIELD MANUAL, CONFIRM THAT YOU HAVE THE APPROPRIATE TRANSDUCERS AND TRACK FOR DIRECT MODE OPERATION ON THE CHOSEN PIPE.
2. SELECT MOUNTING LOCATION:
 - a) CHOOSE LOCATION WHICH REMAINS FULL AT ZERO FLOW.
 - b) WHERE POSSIBLE, LOCATE TRACK ASSY TEN (10) PIPE DIAMETERS OR MORE FROM BEND TO ENSURE FULLY DEVELOPED AND STABLE FLOW PROFILE.
 - c) ON HORIZONTAL PIPE, SELECT HORIZONTAL PLANE, IF POSSIBLE, TO AVOID SEDIMENT BLOCKAGE OF TRANSDUCER SIGNAL.
3. PREPARE PIPE FOR TRACK MOUNT:
 - a) REMOVE GRIT, CORROSION, COATING OR HEAVY PAINT
 - b) CLEAN AND DEGREASE SURFACE
 - c) DO NOT MOUNT OVER FROST.
 - d) CONDITION PIPE SURFACE.

LOCALLY SMOOTH THE PIPE SURFACE TO ACCEPT THE TRANSDUCERS. USE THE ABRASIVE PAD PROVIDED.
4. MOUNT TRACK ON PIPE:
 - a) PLACE TRACK RAIL ASSY (ASSY WITH STRAP) AGAINST PIPE. WHILE HOLDING TRACK, PLACE THE SECOND TRACK ONTO THE PIPE AND HOLD TOGETHER IN PLACE.
 - b) ROTATE ASSY AROUND THE PIPE FOR PROPER POSITIONING. ONCE THAT HAS BEEN ACHIEVED, SECURE THE TRACK RAIL ASSY TO THE PIPE WITH THE STRAP.
5. LOCATE TRANSDUCERS:
 - a) CONSULTING THE 1010 FIELD MANUAL, USE THE INDEX HOLES FOR YOUR APPLICATION AND INSERT PINS.
 - b) APPLY A THIN BAND OF THE ULTRASONIC COUPLANT PROVIDED TO THE BASE OF EACH TRANSDUCER.
 - c) INSERT TRANSDUCERS INTO TRACK AS SHOWN, BANKING AGAINST INDEX PINS. SECURE TRANSDUCERS WITH CLAMPS.
6. MAKE TRANSDUCER CABLE CONNECTIONS IN ACCORDANCE WITH THE APPROPRIATE FLOW COMPUTER INSTALLATION DRAWING AND 1010 FIELD MANUAL.
7. SEE DRAWING 1012TNH-8 AND 1011HNS-8 FOR TRACK AND TRANSDUCER OUTLINE DIMENSIONS.

CONTROLTRON
HAUPPAUGE, NY 11788

INSTALLATION DRAWING 1010 SERIES TRANSDUCERS AND MOUNTING TRACKS

SIZE	CODE IDENT NO.	REV.
C	21614	1012TNH-7 A
SCALE: NONE		SHEET 2 OF 2

DO NOT SCALE THIS DRAWING UNLESS OTHERWISE SPECIFIED. DIMENSIONS ARE IN INCHES (MM) TOLERANCES ARE: INCHES +/- .1 MM +/- .2		CONTRACT NO.
DR	HJJ	6/10/98
CHK		DATE
ENG		DATE
PRD		DATE
APPD		DATE
CERTIFIED		DATE

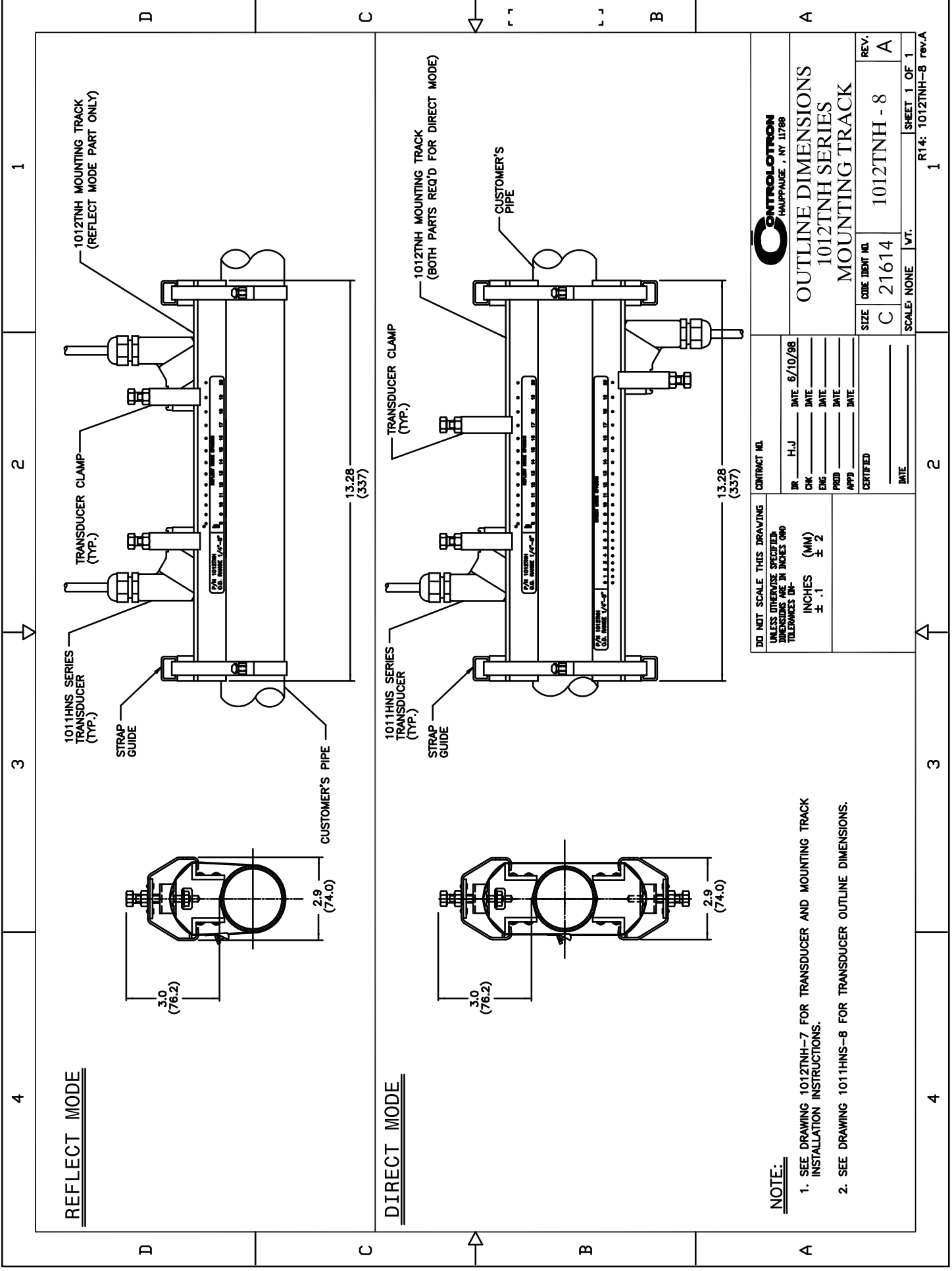

NOTE: 1. SEE DRAWING 1012TNH-7 FOR TRANSDUCER AND MOUNTING TRACK INSTALLATION INSTRUCTIONS. 2. SEE DRAWING 1011HNS-8 FOR TRANSDUCER OUTLINE DIMENSIONS.	DID NOT SCALE THIS DRAWING UNLESS OTHERWISE SPECIFIED DIMENSIONS ARE IN INCHES AND TOLERANCES UNLESS OTHERWISE SPECIFIED INCHES (MM) $\pm .1$ (± 2)	CONTRACT NO. IR H.J. DATE 6/10/98 CHK _____ DATE _____ ENG _____ DATE _____ PRD _____ DATE _____ APPD _____ DATE _____ CERTIFIED _____ DATE _____	CONTROLTRON HAUPPAUGE, NY 11768 OUTLINE DIMENSIONS 1012TNH SERIES MOUNTING TRACK	SIZE C 21614 CODE IDENT NO. 1012TNH-8 REV. A
	SCALE: NONE SHEET 1 OF 1 R14: 1012TNH-8 rev.A	1	2	3

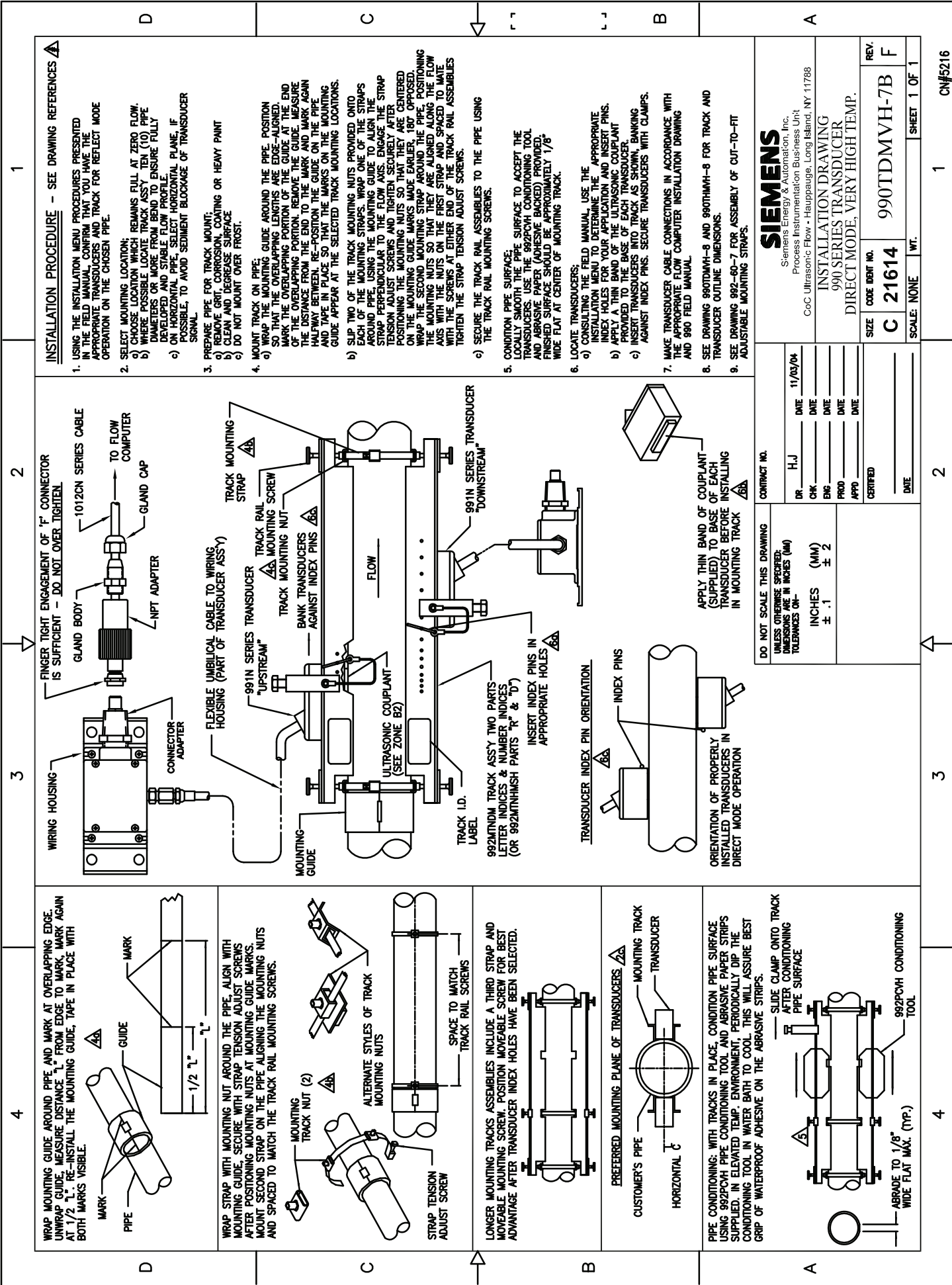

INSTALLATION PROCEDURE - SEE DRAWING REFERENCES

1. USING THE INSTALLATION MENU PROCEDURES PRESENTED IN THE FIELD MANUAL, CONFIRM THAT YOU HAVE THE APPROPRIATE TRANSDUCERS AND TRACK FOR REFLECT MODE OPERATION ON THE CHOSEN PIPE.
2. SELECT MOUNTING LOCATION;
 - a) CHOOSE LOCATION WHICH REMAINS FULL AT ZERO FLOW.
 - b) WHERE POSSIBLE, LOCATE TRACK ASSY TEN (10) PIPE DIAMETERS OR MORE FROM THE TRACK TO ENSURE FULLY DEVELOPED FLOW.
 - c) ON HORIZONTAL PIPE - SELECT HORIZONTAL PLANE, IF POSSIBLE, TO AVOID SEDIMENT BLOCKAGE OF TRANSDUCER SIGNAL.
3. PREPARE PIPE FOR TRACK MOUNT;
 - a) REMOVE GRIT, CORROSION, COATING OR HEAVY PAINT
 - b) CLEAN AND DEBRASS SURFACE
 - c) DO NOT MOUNT OVER FROST.
4. MOUNT TRACK ON PIPE;
 - a) WRAP THE MOUNTING GUIDE AROUND THE PIPE. POSITION SO THAT THE OVERLAPPING LENGTHS ARE EDGE-ALIGNED. MARK THE OVERLAPPING PORTION OF THE GUIDE AT THE END OF THE OVERLAPPING PORTION. REMOVE THE GUIDE. MEASURE THE DISTANCE FROM THE END TO THE MARK AND MARK AGAIN HALFWAY BETWEEN. RE-POSITION THE GUIDE ON THE PIPE AND TAPE IN PLACE SO THAT THE MARKS ON THE MOUNTING GUIDE APPEAR AT THE SELECTED TRACK MOUNTING LOCATIONS.
 - b) SLIP TWO OF THE TRACK MOUNTING NUTS PROVIDED ONTO EACH OF THE MOUNTING STRAPS. WRAP ONE OF THE STRAPS AROUND PIPE, USING THE MOUNTING GUIDE TO ALIGN THE STRAP PERPENDICULAR TO THE FLOW AXIS. ENGAGE THE STRAP TENSION ADJUST SCREWS AND TIGHTEN SECURELY AFTER POSITIONING THE MOUNTING NUTS SO THAT THEY ARE CENTERED ON THE MOUNTING GUIDE MARKS MADE EARLIER, 180° OPPOSED. WRAP THE SECOND MOUNTING STRAP AROUND THE PIPE, POSITIONING THE MOUNTING NUTS SO THAT THEY ARE ALIGNED ALONG THE FLOW AXIS WITH THE NUTS ON THE FIRST STRAP AND SPACED TO MATE WITH THE SCREWS AT EITHER END OF THE TRACK RAIL ASSEMBLY. TIGHTEN THE STRAP TENSION ADJUST SCREWS.
 - c) SECURE THE TRACK RAIL ASSEMBLY TO THE PIPE USING THE TRACK RAIL MOUNTING SCREWS.
5. CONDITION PIPE SURFACE;
 - a) LOCALLY SMOOTH THE PIPE SURFACE TO ACCEPT THE TRANSDUCERS. USE THE 992PCVH CONDITIONING TOOL AND ABRASIVE PAPER (ADHESIVE BACKED) PROVIDED. FINISHED SURFACE SHOULD BE APPROXIMATELY 1/8" WIDE FLAT AT CENTER OF MOUNTING TRACK.
6. LOCATE TRANSDUCERS;
 - a) CONSULTING THE FIELD MANUAL, USE THE INDEX HOLES FOR YOUR APPLICATION AND INSERT PINS.
 - b) APPLY A THIN BAND OF THE ULTRASONIC COUPLANT PROVIDED TO THE BASE OF EACH TRANSDUCER.
 - c) INSERT TRANSDUCERS INTO TRACK AS SHOWN, BANKING AGAINST INDEX PINS. SECURE TRANSDUCERS WITH CLAMPS.
7. MAKE TRANSDUCER CABLE CONNECTIONS IN ACCORDANCE WITH THE APPROPRIATE FLOW COMPUTER INSTALLATION DRAWING AND 990 FIELD MANUAL.
8. SEE DRAWING 990TDMVH-8 AND 990TDMVH-8 FOR TRACK AND TRANSDUCER OUTLINE DIMENSIONS.
9. SEE DRAWING 992-80-7 FOR ASSEMBLY OF CUT-TO-FIT ADJUSTABLE MOUNTING STRAPS.

DO NOT SCALE THIS DRAWING UNLESS OTHERWISE SPECIFIED. DIMENSIONS ARE IN INCHES (MM) TOLERANCES ON-

INCHES ± .1 (MM) ± .2

CONTRACT NO. _____

DR HJJ DATE 11/03/04

CHK _____ DATE _____

ENG _____ DATE _____

PROD _____ DATE _____

APPD _____ DATE _____

CERTIFIED _____ DATE _____

SCALE: NONE WT. _____ SHEET 1 OF 1

SIEMENS
Siemens Energy & Automation, Inc.
Process Instrumentation Business Unit
CoC Ultrason-c Flow - Hauppauge, Long Island, NY 11788

INSTALLATION DRAWING
990 SERIES TRANSDUCER
DIRECT MODE, VERY HIGH TEMP.

SIZE CODE IDENT NO. **C 21614** REV. **F**

990TDMVH-7B

DO NOT SCALE THIS DRAWING UNLESS OTHERWISE SPECIFIED. DIMENSIONS ARE IN INCHES (MM) TOLERANCES ON-

INCHES ± .1 (MM) ± .2

CONTRACT NO. _____

DR HJJ DATE 11/03/04

CHK _____ DATE _____

ENG _____ DATE _____

PROD _____ DATE _____

APPD _____ DATE _____

CERTIFIED _____ DATE _____

SCALE: NONE WT. _____ SHEET 1 OF 1

DO NOT SCALE THIS DRAWING UNLESS OTHERWISE SPECIFIED. DIMENSIONS ARE IN INCHES (MM) TOLERANCES ON-

INCHES ± .1 (MM) ± .2

CONTRACT NO. _____

DR HJJ DATE 11/03/04

CHK _____ DATE _____

ENG _____ DATE _____

PROD _____ DATE _____

APPD _____ DATE _____

CERTIFIED _____ DATE _____

SCALE: NONE WT. _____ SHEET 1 OF 1

DO NOT SCALE THIS DRAWING UNLESS OTHERWISE SPECIFIED. DIMENSIONS ARE IN INCHES (MM) TOLERANCES ON-

INCHES ± .1 (MM) ± .2

CONTRACT NO. _____

DR HJJ DATE 11/03/04

CHK _____ DATE _____

ENG _____ DATE _____

PROD _____ DATE _____

APPD _____ DATE _____

CERTIFIED _____ DATE _____

SCALE: NONE WT. _____ SHEET 1 OF 1

1

2

3

4

1

CN#5216

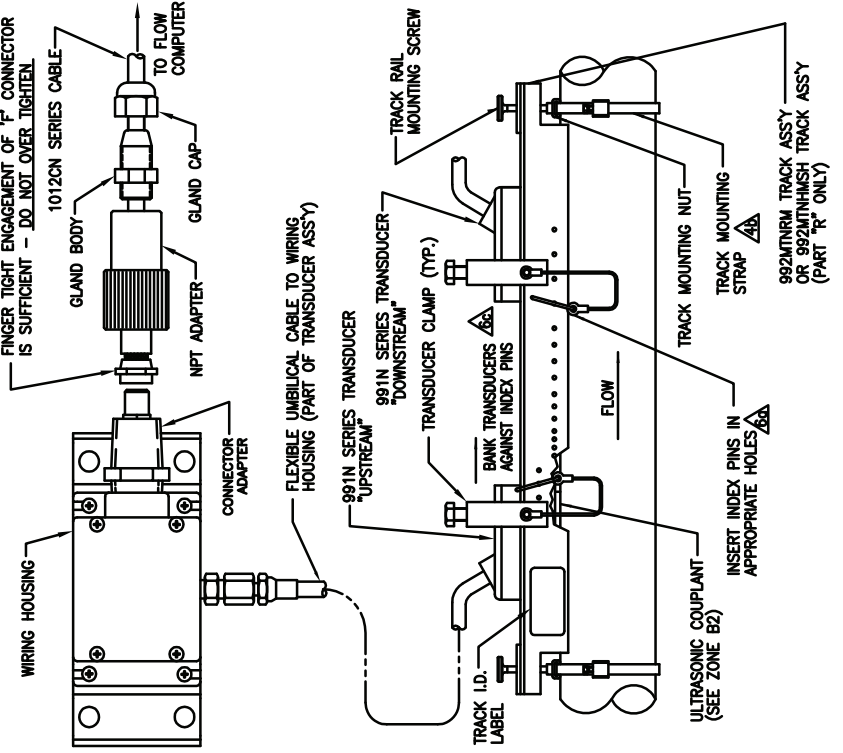
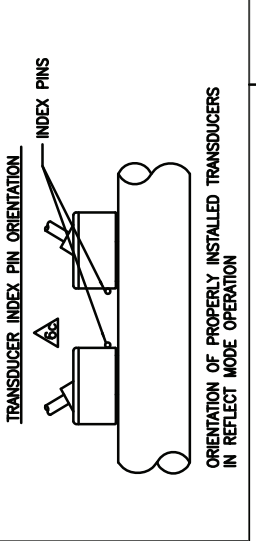
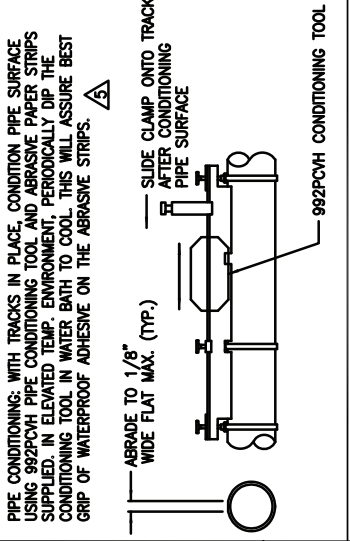
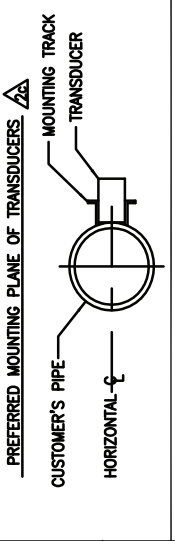
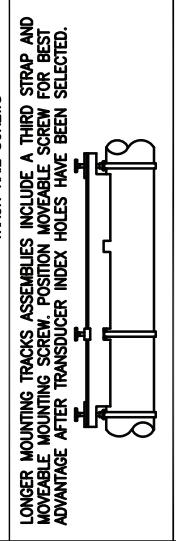
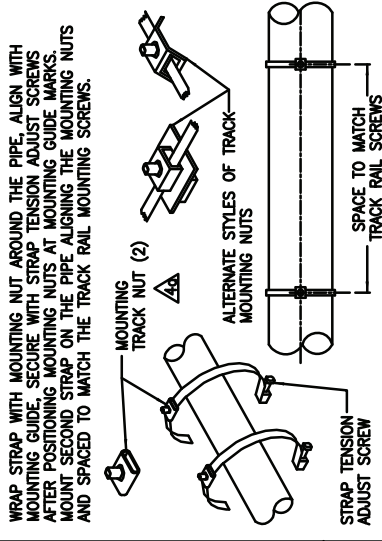

- INSTALLATION PROCEDURE - SEE DRAWING REFERENCES A**
- USING THE INSTALLATION MENU PROCEDURES PRESENTED IN THE FIELD MANUAL, CONFIRM THAT YOU HAVE THE APPROPRIATE TRANSDUCERS AND TRACK FOR REFLECT MODE OPERATION ON THE CHOSEN PIPE.
 - SELECT MOUNTING LOCATION:
 - CHOOSE LOCATION WHICH REMAINS FULL AT ZERO FLOW.
 - WHERE POSSIBLE LOCATE TRACK ASSY TEN (10) PIPE DIAMETERS OR MORE FROM BEND TO ENSURE FULLY DEVELOPED AND STABLE FLOW PROFILE.
 - ON HORIZONTAL PIPE, SELECT HORIZONTAL PLANE, IF POSSIBLE, TO AVOID SEDIMENT BLOCKAGE OF TRANSDUCER SIGNAL.
 - PREPARE PIPE FOR TRACK MOUNT:
 - REMOVE GRIT, CORROSION, COATING OR HEAVY PAINT
 - CLEAN AND DEGREASE SURFACE.
 - DO NOT MOUNT OVER FROST.
 - MOUNT TRACK ON PIPE:
 - SLIP ONE OF THE MOUNTING NUTS PROVIDED ONTO EACH OF THE MOUNTING STRAPS. WRAP THE STRAPS AROUND THE PIPE AT THE SELECTED LOCATION AND ENGAGE THE ADJUSTING SCREWS. POSITION THE MOUNTING NUTS IN LINE WITH THE FLOW AXIS AND SPACED TO MATE WITH THE STRAPS AT EITHER END OF THE TRACK ASSEMBLY. SECURE THE STRAPS (AND NUTS) BY TIGHTENING THE MOUNTING STRAP ADJUSTING SCREWS.
 - SECURE THE TRACK RAIL ASSEMBLIES TO THE PIPE USING THE TRACK RAIL MOUNTING SCREWS.
 - CONDITION PIPE SURFACE:
 - LOCALLY SMOOTH THE PIPE SURFACE TO ACCEPT THE TRANSDUCERS. USE THE 992PCVH CONDITIONING TOOL AND ABRASIVE PAPER (ADHESIVE BACKED) PROVIDED. FINISHED SURFACE SHOULD BE APPROXIMATELY 1/8" WIDE FLAT AT CENTER OF MOUNTING TRACK.
 - LOCATE TRANSDUCERS:
 - CONSULTING THE FIELD MANUAL, USE THE INSTALLATION MENU TO DETERMINE THE APPROPRIATE INDEX HOLES FOR YOUR APPLICATION AND INSERT PINS.
 - APPLY A THIN BAND OF THE ULTRASONIC COUPLANT PROVIDED TO THE BASE OF EACH TRANSDUCER.
 - INSERT TRANSDUCERS INTO TRACK AS SHOWN, BANKING AGAINST INDEX PINS. SECURE TRANSDUCERS WITH CLAMPS.
 - MAKE TRANSDUCER CABLE CONNECTIONS IN ACCORDANCE WITH THE APPROPRIATE FLOW COMPUTER INSTALLATION DRAWING AND 990 FIELD MANUAL.
 - SEE DRAWING 98TRMH-8 AND 980THMH-8 FOR TRACK AND TRANSDUCER OUTLINE DIMENSIONS.
 - SEE DRAWING 982-60-7 FOR ASSEMBLY OF CUT-TO-FIT ADJUSTABLE MOUNTING STRAPS.

<p>SIEMENS Siemens Energy & Automation, Inc. Process Instrumentation Business Unit CoC Ultrasonic Flow - Heppauge, Long Island, NY 11788</p>		<p>INSTALLATION DRAWING 990 SERIES TRANSDUCER REFLECT MODE, VERY HIGH TEMP.</p>	
<p>DO NOT SCALE THIS DRAWING UNLESS OTHERWISE SPECIFIED. DIMENSIONS ARE IN INCHES (MM) TOLERANCES ON-</p>	<p>CONTRACT NO.</p>	<p>DATE 11/03/04</p>	<p>REV. F</p>
<p>INCHES ± .1 (MM) ± .2</p>	<p>DR HJJ</p>	<p>DATE</p>	<p>SIZE C</p>
	<p>CHK</p>	<p>DATE</p>	<p>CODE IDENT NO. 990TRMH-7B</p>
	<p>ENG</p>	<p>DATE</p>	<p>SCALE: NONE</p>
	<p>PROD</p>	<p>DATE</p>	<p>WT.</p>
	<p>APPD</p>	<p>DATE</p>	<p>SHEET 1 OF 1</p>
	<p>CERTIFIED</p>	<p>DATE</p>	<p>CN#5216</p>

STAINLESS STEEL, HASTELLOY "C" & TITANIUM PIPE

Sched.	Size	1/2	3/4	1	1 1/4	1 1/2	2	2 1/2	3	3 1/2	4	5	6	8	10	12	14	16	18	20	22	24	
5S	O.D.	0.840	1.050	1.315	1.660	1.900	2.375	2.875	3.500	4.000	4.500	5.563	6.625	8.625	10.750	12.750	14.000	16.000	18.000	20.000	22.000	24.000	
	I.D.	0.710	0.920	1.185	1.530	1.770	2.245	2.709	3.334	3.834	4.334	5.345	6.407	8.407	10.482	12.438	13.688	15.670	17.670	19.634	21.624	23.563	
	Wall	0.065	0.065	0.065	0.065	0.065	0.083	0.083	0.083	0.083	0.083	0.109	0.109	0.109	0.134	0.156	0.156	0.165	0.165	0.188	0.188	0.218	
10S	I.D.	0.674	0.884	1.097	1.442	1.682	2.157	2.635	3.260	3.760	4.260	5.295	6.357	8.329	10.420	12.390	13.624	15.624	17.624	19.564	21.564	23.500	
	Wall	0.083	0.083	0.109	0.109	0.109	0.120	0.120	0.120	0.120	0.120	0.134	0.134	0.148	0.165	0.180	0.188	0.188	0.188	0.218	0.218	0.250	
	I.D.	0.622	0.824	1.049	1.380	1.610	2.067	2.469	3.068	3.548	4.026	5.047	6.065	7.981	10.020	12.000							
40S	Wall	0.109	0.113	0.133	0.140	0.145	0.154	0.203	0.216	0.226	0.237	0.258	0.280	0.322	0.365	0.375							
	I.D.	0.546	0.742	0.957	1.278	1.500	1.939	2.323	2.900	3.364	3.826	4.813	5.761	7.625	9.750	11.750	13.000	15.000	17.000	19.000	21.000	23.000	25.000
	Wall	0.147	0.154	0.179	0.191	0.200	0.218	0.276	0.300	0.318	0.337	0.375	0.432	0.500	0.500	0.500	0.500	0.500	0.500	0.500	0.500	0.500	0.500
80S	I.D.	0.252	0.434	0.599	0.896	1.100	1.503	1.771	2.300	2.728	3.152	4.063	4.897	6.875	8.750	10.750							
	Wall	0.294	0.308	0.358	0.400	0.436	0.552	0.600	0.636	0.674	0.750	0.864	0.875	1.000	1.000								
	I.D.																						

CARBON STEEL and PVC PIPE

Pipe	Size	1/2	3/4	1	1 1/4	1 1/2	2	2 1/2	3	3 1/2	4	5	6	8	10	12	14	16	18	20	22	24	26	28	30	32	34	36	42
Stand-ard	O.D.	0.840	1.050	1.315	1.660	1.900	2.375	2.875	3.500	4.000	4.500	5.563	6.625	8.625	10.750	12.750	14.000	16.000	18.000	20.000	22.000	24.000	26.000	28.000	30.000	32.000	34.000	36.000	42.000
	I.D.	0.622	0.824	1.049	1.380	1.610	2.067	2.469	3.068	3.548	4.026	5.047	6.065	7.981	10.020	12.000	13.250	15.250	17.250	19.250	21.250	23.250	25.250	27.250	29.250	31.250	33.250	35.250	41.250
	Wall	0.109	0.113	0.133	0.140	0.145	0.203	0.216	0.226	0.237	0.258	0.280	0.322	0.365	0.375	0.375	0.375	0.375	0.375	0.375	0.375	0.375	0.375	0.375	0.375	0.375	0.375	0.375	0.375
Extra Strong (XS)	I.D.	0.546	0.742	0.957	1.278	1.500	1.939	2.323	2.900	3.364	3.826	4.813	5.761	7.625	9.750	11.750	13.000	15.000	17.000	19.000	21.000	23.000	25.000	27.000	29.000	31.000	33.000	35.000	41.000
	Wall	0.147	0.154	0.179	0.191	0.200	0.218	0.276	0.300	0.318	0.337	0.375	0.432	0.500	0.500	0.500	0.500	0.500	0.500	0.500	0.500	0.500	0.500	0.500	0.500	0.500	0.500	0.500	0.500
	I.D.	0.252	0.434	0.599	0.896	1.100	1.503	1.771	2.300	2.728	3.152	4.063	4.897	6.875	8.750	10.750													
Double Extra (XXS)	Wall	0.294	0.308	0.358	0.400	0.436	0.552	0.600	0.636	0.674	0.750	0.864	0.875	1.000	1.000														
	I.D.																												
	Wall																												
Sched. 10	I.D.																												
	Wall																												
	I.D.																												
Sched. 20	I.D.																												
	Wall																												
	I.D.																												
Sched. 30	I.D.																												
	Wall																												
	I.D.																												
Sched. 40	I.D.																												
	Wall																												
	I.D.																												
Sched. 60	I.D.																												
	Wall																												
	I.D.																												
Sched. 80	I.D.																												
	Wall																												
	I.D.																												
Sched. 100	I.D.																												
	Wall																												
	I.D.																												
Sched. 120	I.D.																												
	Wall																												
	I.D.																												
Sched. 140	I.D.																												
	Wall																												
	I.D.																												
Sched. 160	I.D.																												
	Wall																												
	I.D.																												

NON-STANDARD CARBON

Size	10	20	24
O.D.	10.750	20.000	24.000
I.D.	10.192	19.375	23.375
Wall	0.279	0.312	0.312

The above sizes are produced by pipe mills but dimensions do not conform to any regular standard or schedule.

- △ These materials are generally available in Schedules 40 and 80 only.
- ◇ Wall Thickness of Schedule 5S & 10S does not permit threading in accordance with the American Standard for Pipe Threads (ASA No. B2.1)
- ⊗ Wall thickness identical with thickness of "Standard Weight" pipe.
- ▲ Wall Thickness identical with thickness of "Extra-Heavy" pipe.
- * These do not conform to American Standard B36. 10.

PIPE WEIGHT FORMULA FOR STEEL PIPE (lbs per foot)
10.68 (D-t), where D=Outside Diameter and t=Wall Thickness



Siemens Industry Inc.
Industry Automation Division
Coc Ultrasonic Flow
Hauptpage, New York 11788 USA
Web: www.usa.siemens.com

Glossary

Alphanumeric Field

An 8-character data entry field that allows you to specify a Site Name or a Security code.

Arrow Keys

Use the <Up, Down, Left and Right> Arrows to navigate through the Installation Menu in their respective directions. The <Up or Down> Arrows allow you also to scroll through option list items.

Asterisk

Refers to the marker used in the Installation Menu to indicate a current option list selection. When you access an option list, you can move the asterisk with the <Up or Down> Arrows to a new selection, then press <ENTER> to select the item.

BACnet

BACnet is a standard communication protocol for **B**uilding **A**utomation and **C**ontrol **N**etworks developed by the American Society of Heating, Refrigerating and Air-Conditioning Engineers (ASHRAE). The FST020 functions as a BACnet slave device on a BACnet MSTP RS485 network.

CLR (Clear) Key

Use the <CLR> key to erase a numeric value or clear a selection from a multiple select option list.

Cursor

This refers to the highlighted text and the arrow cursor that you move via the arrow direction when navigating through menus or menu cells.

Data Entry

Refers to data entered into a menu cell (either numeric or option list selection).

Datalogger Memory

Memory segment that stores data items logged during operation. You can view the Datalogger contents either on-screen or transmit it to an external device via the RS-232 serial port. The amount of Datalogger memory depends on how many sites reside in Site Storage memory.

ENTER Key

Use the <ENTER> key to store a current numeric value or option list item.

Flow meter

Refers to the flow meter itself (the transmitter and sensors combined).

Graphic Screen

Refers to the integral display screen.

Initial Makeup

An internal process performed during installation, where the flow meter acquires its receive signal and enhances other parameters for optimal operation at a site.

In-process Makeup

An internal process where the flow meter recovers its Initial Makeup parameters after a fault condition interrupts operation.

Installation Menu

The flow meter's overall menu structure. It allows you to define all aspects of operation for the flow meter.

Interface m/s

Refers to an alarm function that declares the passage of a liquid or gas interface by a comparison of the relative sonic velocities of the two liquids or two gases.

LAPTOT

Refers to a system function that freezes the Totalizer display, while the Totalizer continues to update its registers.

Local Display

Refers to the transmitter integral display screen.

Menu

Sub-sections of the Installation Menu that allow you to define specific operational functions (e.g., RS-232 Setup).

Menu Cell

A location within a menu where you define either a single numeric value or option list selection that supports the Sub-Menu's function. Certain view-only menu cells show reference data appropriate to the current application.

ModBus

ModBus is an open protocol that has been in existence since 1980 and has become a de facto standard for communication in supervisory and data acquisition applications. It uses registers to address data which can be formatted in various types including, real, integer, & binary (coils).

NEGFLOW

Totalizer mode for negative flow total only.

NETFLOW

Totalizer mode that combines positive and negative flow totals.

NOTOT

System function that disables the internal Totalizer.

Number Index

Computed sensor spacing index based on the estimated sonic velocity measurement. This Index can not be overridden by installer.

Numeric Data

Refers to a value entered into a menu cell. An example would be the pipe outer diameter.

Numeric Entry

Refers to a number you type into menu cell that stores numeric data.

Numeric Keys

Use the Numeric keys to type a numeric value where appropriate.

OpSys ROM

The Read-Only-Memory that stores its basic operating instructions and permanent defaults.

Option List

Lists of options presented at menu cells that allow you to select either a single item or multiple items (depending on the function that the menu cell controls).

Parameters

Refers to value (either numeric or list selection) stored in a menu cell.

POSFLOW

Totalizer mode for positive flow total only.

Register

Refers to a memory location used by the flow meter to store data such as the flow total, etc.

Sensor

Refers to entire spool piece in some instances. Flow sensors that the flow meter uses to measure the flow rate. Also called transducer and abbreviated as Xdcr.

Site Name

A user-entered name that the flow meter associates with a stored Site Setup. You retrieve a particular Site by selecting its name from a site name list.

Site Setup

A collection of parameters used by the flow meter to service a specific site (or location). The flow meter allows you to store several independent Site Setups.

Site Storage Memory

Section of RAM allocated for permanent data storage. This memory segment stores inactive site setups (including a backup of active site). The flow meter's Site Setup storage capacity depends on the dynamic memory allocation as dictated by each application. In addition, the flow meter uses Site Storage Memory to store configurable operating parameters such as pipe, liquid or gas tables.

Spacing Index

Refers to the Number Index used by the flow meter to determine the space between the upstream and downstream sensors on clamp-on systems.

Spacing Offset

Fixed sensor offset assigned by the flow meter. This can be overridden by the installer.

TOTCNT

A Totalizer pulse count function used for Batching or Sampling.

Transducer

Also known as sensor.

Vaer

The flow meter's aeration percent output.

Vps

The sonic propagation velocity of a pipe.

Vs

The sonic velocity of a liquid or gas.

Index

C

CE marked equipment, 11
CE-mark, 11
Customer Support Hotline, 107

D

Decontamination, 108
Device inspection, 7

H

History, 7
Hotline, 107

I

Internet
 Contact person, 108
 Support, 108

L

Lithium batteries
 Safety, 12

M

Maintenance, 107

R

Repair, 107
Return procedures, 108

S

Safety notes, 9
Service, 107, 108
SmartSlew, 86
Support, 108
Symbols, (Refer to warning symbols)

T

Time Average, 86

W

Warning symbols, 10

For more information

www.siemens.com/flow

Siemens Industry, Inc.
Industry Automation Division
Ultrasonic Flow
Hauppauge, NY 11788
USA

Subject to change without prior notice
Order No.: A5E03086487
Lit. No.: A5E03086487-AH
© Siemens AG 02.2014

www.siemens.com/processautomation