

SMARTLINK[®] METER

Digital Self-checking Thermal Mass Flow Meter



- Precise, repeatable mass flow measurement for fuel, air and combustion streams
- Displays instantaneous standard rate and totalized flow without calculations
- Advanced calibration extends accuracy over wider ranges of fluid temperatures
- Thermal mass flow technology provides reliable measurements with no moving parts
- Provides excellent accuracy over a wide turndown range
- Redundancy and an alarm output for “on-line” self-checking and fail-safe operation
- Monitors, displays, and outputs air/fuel ratio when two meters are electrically “linked”
- Viewable flow totalizer without batteries or external equipment
- In-line flow body incorporates conditioning screens to reduce straight-run piping requirements, eliminating many installation problems common to insertion type meters
- Large, convenient local display for ease of use. No PC or other interface necessary for configuration and operation
- Fail-safe alarm, limit and analog outputs for easy integration into PLC or DCS systems
- Factory Mutual (FM) approved for Hazardous Locations, Class I, Division 2, Groups A,B,C, and D and Class I, Zone 2, Group IIC

Product overview

SMARTLINK® METER is a highly accurate and repeatable mass flow meter well suited for monitoring fuel and air. The meter is built with a rugged NEMA 4X (IP66) enclosure for industrial applications. The design is based on a well established thermal mass flow sensing principle and innovative electronics that provide many self-checking functions to ensure measurement integrity.

The meter uses a constant temperature differential (ΔT) technique with two matched, platinum RTD (Resistive Temperature Device) elements in a rugged, stainless probe assembly. One RTD measures fluid temperature and an "intelligent" bridge circuit heats the second RTD element, maintaining a constant temperature differential above the temperature of the process fluid. Based on the amount of power delivered to the heated element, the precise mass flow rate is established by the on-board microprocessor. The highly integrated sensor probe and electronic design permits fully automated factory calibration, providing every manufactured unit with out-of-the-box measurement accuracy.

SMARTLINK® METER incorporates an input/output (I/O) module with analog 4-20mA current loops for monitoring flow and air/fuel ratio or fluid temperature. A redundant system design is employed for "on-line" flow meter test functions and fail-safe alarm, limit, and test status indication. A liquid crystal display (LCD) and a membrane switch keypad provide easy meter configuration and local viewing of meter status. Each unit is calibrated for air or natural gas and includes an "in-line" flow body that conditions the fluid velocity profile and sets the depth of the probe assembly for proper measurement in the flow stream.

Available SMARTLINK® METER models and sizes

In-line natural gas meters				
Model number	Nominal flow body size (in)	Minimum flow (scfh)	Maximum flow (scfh)	Max DP @ STP [1] [2] (" wc)
0200 SLM	2	160	8,000	10.0
0300 SLM	3	360	18,000	10.0
0400 SLM	4	640	32,000	11.4
0600 SLM	6	1500	75,000	10.9

[1] STP (Standard Temperature and Pressure) conditions for scfh (Standard Cubic Feet per Hour) units are 60°F and 14.73 psia as per ANSI/API MPMS (Manual of Petroleum Measurement Standards), 14.3.1

[2] Stated differential pressures (DP) assume STP conditions and the maximum rated in-line meter flow rate with a natural gas density of 0.0425 lb/ft³.

In-line air meters				
Model number	Nominal flow body size (in)	Minimum flow (scfh)	Maximum flow (scfh)	Max DP @ STP [1] [2] (" wc)
0800 SLM	8	2800	140,000	12.1
1200 SLM	12	6200	310,000	12.0
1600 SLM	16	9700	485,000	11.8
2000 SLM	20	15,000	750,000	11.0
2400 SLM	24	22,000	1,100,000	11.7
2800 SLM	28	30,000	1,500,000	11.7

[1] STP (Standard Temperature and Pressure) conditions for scfh (Standard Cubic Feet per Hour) units are 60°F and 14.73 psia as per ANSI/API MPMS (Manual of Petroleum Measurement Standards), 14.3.1

[2] Stated differential pressures (DP) assume STP conditions and the maximum in-line meter flow rate with an air density of 0.076 lb/ft³ and 25% RH (relative humidity)



Typical applications

SMARTLINK® METER is a rugged, industrial instrument for use with natural gas and air. In addition to single stream combustion flows and totalization, SMARTLINK® METER can be installed in sets to monitor ratios or relative flows. With intelligent, self-monitoring features, the meter provides ease of use and enhanced information on processes.

Typical SMARTLINK® METER installations also may include:

- Measuring gas consumption on industrial furnaces, ovens, oxidizers, or process heaters, especially in facilities with multiple combustion systems on one gas company meter
- Checking or controlling air and fuel ratio to industrial burners for efficiency optimization
- Verifying or controlling air and fuel ratio to industrial burners for emissions compliance
- Monitoring air and fuel ratio for products sensitive to reducing atmospheres or oxidizing environments
- Measuring burner air and fuel flows for set-up and adjustment
- Monitoring critical gas flows to alarm maximum or minimum rates
- Measuring and monitoring relative rates of process gases or combustion gases for critical process heating appliances
- Verification of gas usage to identify optimization targets or to expose wasted fuel within in-plant piping and equipment

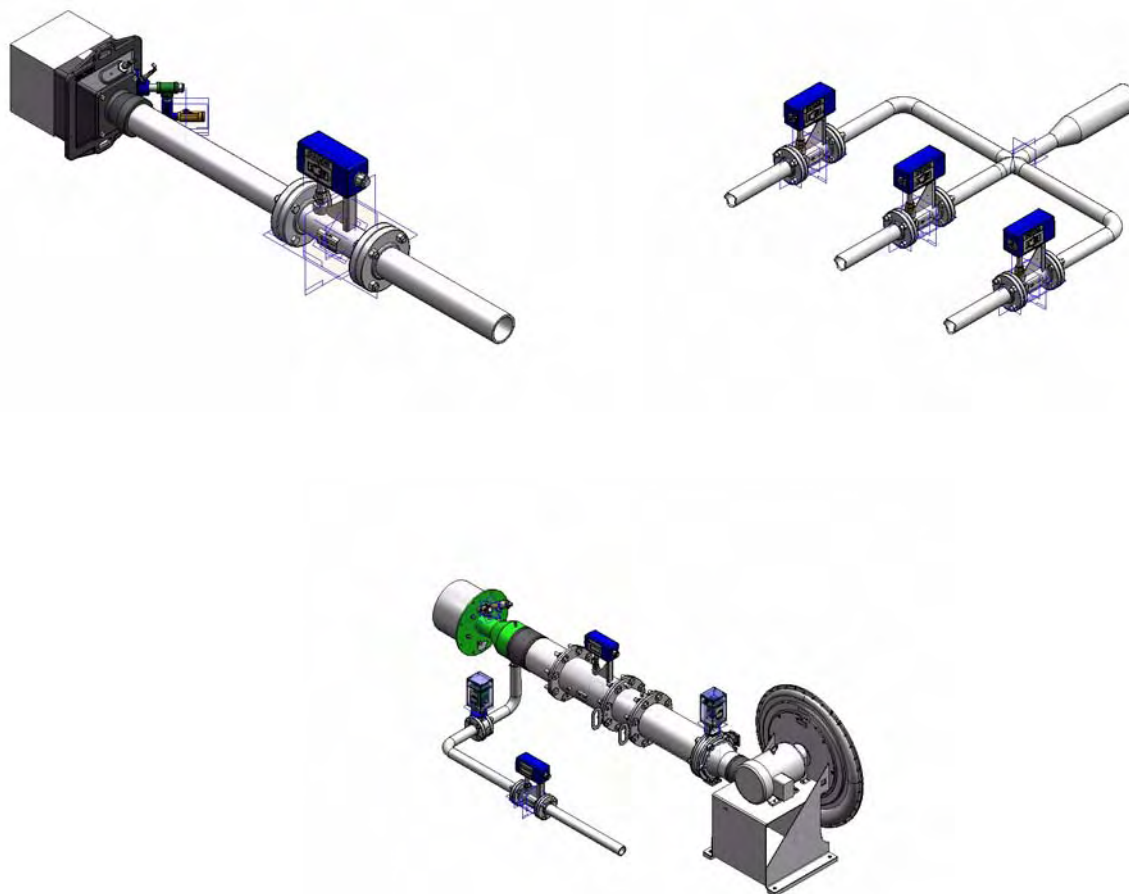

Dimensions and weights

Natural gas models

- 1) Over raised faces
- 2) Drawing of 0200 SLM only
- 3) Flow direction right to left

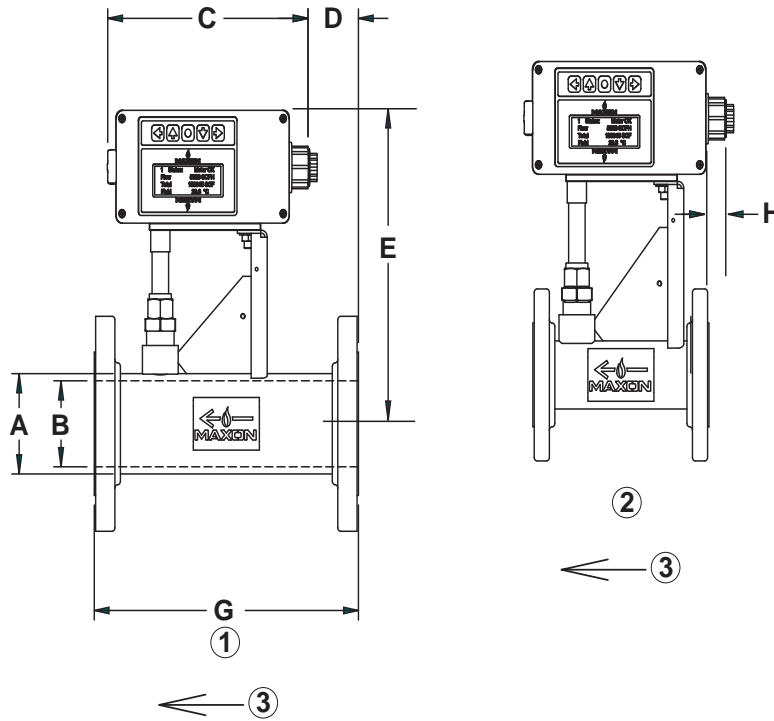

Dimensions in inches unless stated otherwise

Model	Nominal size	A	B	C	D	E	G	H	Approx. weight lb
0200 SLM	2.0	2.4	2.0	9.1	-	10.9	8.0	0.7	19
0300 SLM	3.0	3.5	3.0	9.1	2.3	10.9	12.0	-	32
0400 SLM	4.0	4.5	3.9	9.1	5.3	10.9	16.0	-	49
0600 SLM	6.0	6.6	6.0	9.1	11.3	11.8	24.0	-	83

Air models

- 1) Jack bolts
- 2) Over gaskets
- 3) Flow direction from right to left

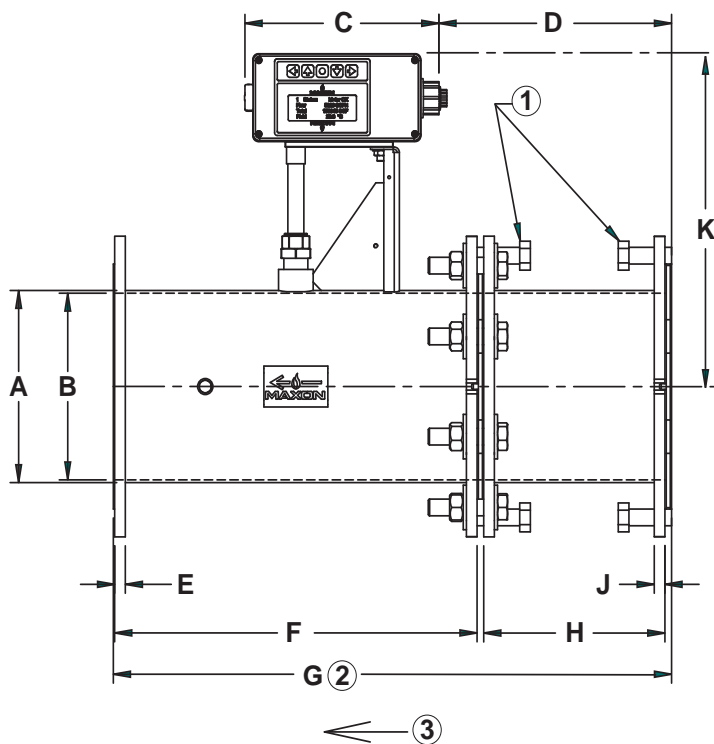

Dimensions in inches unless stated otherwise												
Model	Nominal size	A	B	C	D	E	F	G	H	J	K	Approx. weight lb
0800 SLM	8.0	8.6	8.4	9.1	10.9	0.5	17.0	26.2	8.5	0.5	14.9	74.0
1200 SLM	12.0	12.8	12.5	9.1	18.9	0.5	25.0	38.2	12.5	0.5	14.9	142.0
1600 SLM	16.0	16.0	15.8	9.1	25.9	0.5	32.0	48.7	16.0	0.5	16.4	225.0
2000 SLM	20.0	20.0	19.8	9.1	33.9	0.5	40.0	60.7	20.0	0.5	18.4	299.0
2400 SLM	24.0	24.0	23.8	9.1	41.9	0.5	48.0	72.7	24.0	0.5	20.4	401.0
2800 SLM	28.0	28.0	27.8	9.1	49.9	0.5	48.0	76.7	28.0	0.5	22.4	497.0