

# EnviroRanger ERS 500

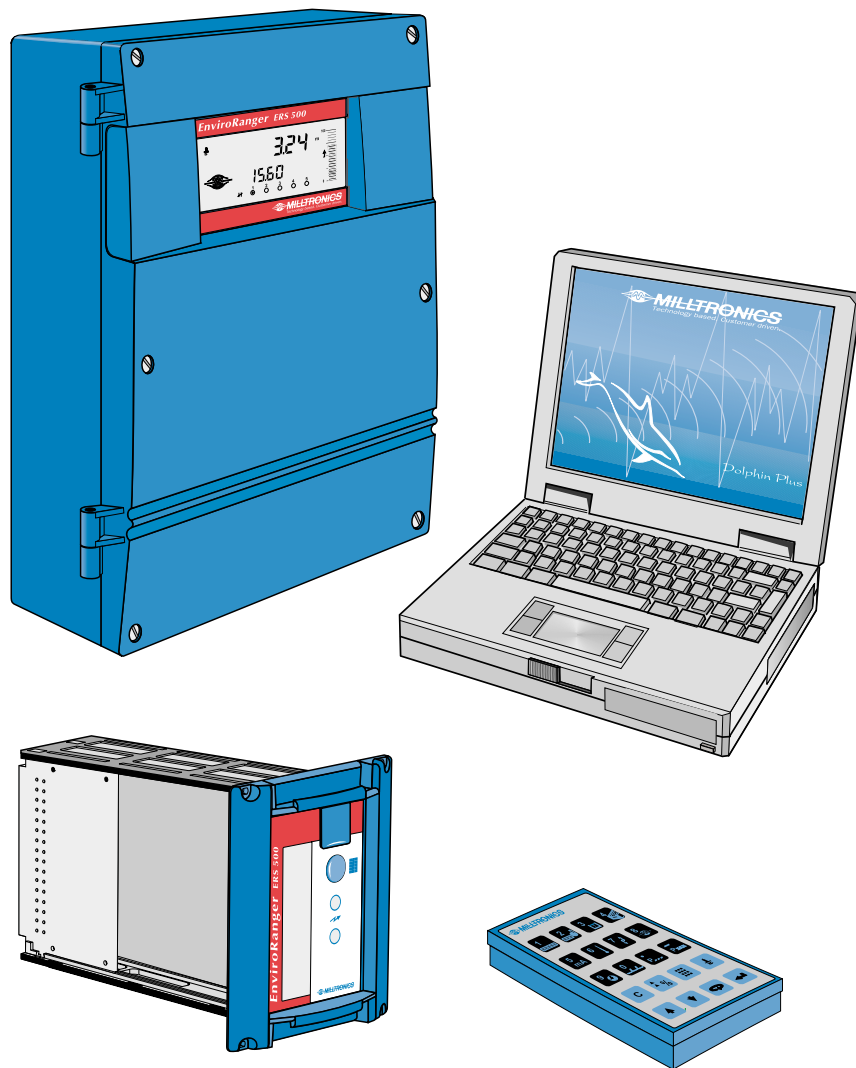

*Programming Reference*

*PL-556*

*Nov. 1999*

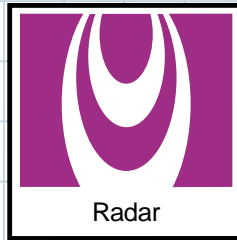

**A**t Milltronics, we endeavour to design equipment that is simple to use and reliable in its operation, with the aim of satisfying our customers' needs.

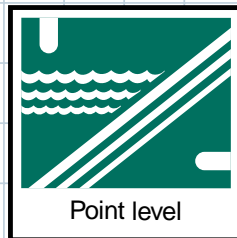
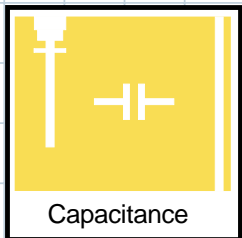

Milltronics has been designing and manufacturing electronics based process measurement equipment since 1954. Our fields of expertise include continuous and point level measurement, weighing and feeding systems and motion sensing. Technologies include ultrasonic, capacitance and microwave radar.

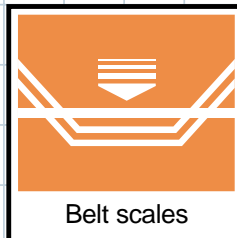

Milltronics sells and markets world wide through subsidiaries, distributors and representatives. Through continuous improvement, we are striving to provide our customers with first rate sales information, engineering assistance and after sales support.

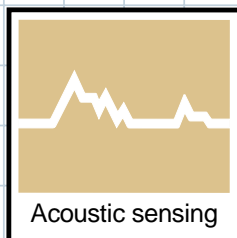
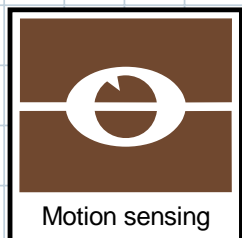
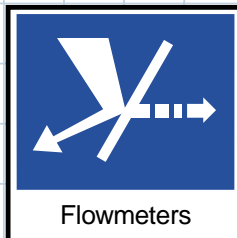

For more details on our products and services, please contact us and we will provide you with a listing of the offices or representatives nearest you.

# Table of Contents

---

<b>Introduction .....</b>	<b>7</b>
About this Manual .....	7
Using this Manual .....	8
<b>About the EnviroRanger .....</b>	<b>9</b>
Display .....	10
Hand Programmer .....	11
Readings in Run Mode .....	12
<b>Programming the EnviroRanger .....</b>	<b>15</b>
Starting Program Mode .....	16
Parameter Indexing.....	16
Changing Parameters (Dolphin Plus).....	17
Changing Parameters (Hand Programmer) .....	18
Using Units or Percent (%).....	18
Special Parameters.....	19
Parameter Reset.....	19
Security .....	20
Displays .....	20
<b>Planning Considerations .....</b>	<b>21</b>
Review the Application.....	21
Design the Control Scheme .....	21
Install the EnviroRanger.....	21
Program the EnviroRanger .....	21
Test the Installation.....	22
Document the Installation.....	22
<b>Application Examples .....</b>	<b>23</b>
Simple Level and Alarms .....	23
Pump Control .....	26
Open Channel Monitoring (OCM) .....	32
Gate Control.....	44
Rake (Screen) Control .....	46
<b>Testing the Configuration.....</b>	<b>49</b>
Simulation .....	49
I/O Checkout.....	51
Application Test .....	52
Programming Documentation .....	52
<b>Parameter Reference.....</b>	<b>55</b>
How to Read the Reference.....	55
Quick Start (P001 to P009) .....	57
Volume (P050 to P055).....	62

Display and Reading (P060 to P062) .....	66
Failsafe (P070 to P072) .....	69
Relays (P100 to P119) .....	72
Pump Setpoint Modifiers (P121 and P122) .....	88
Independent Relay Failsafe (P129) .....	90
Advanced Pump Control Modifiers (P130 to P136) .....	91
Pump Energy Cost Reduction (P140 to P145) .....	95
Overflow / Underflow (P160 to P169) .....	99
Flush Systems (P170 to P173) .....	103
Pump Efficiency (P180 to P186) .....	105
mA Input (P250 to P254) .....	108
mA Input Trim (P260 to P262) .....	110
Discrete Input Functions (P270 to P275) .....	111
Data Logging (P300 to P321) .....	115
Record Temperatures (P300 to P303) .....	115
Record Readings (P304 and P305) .....	117
Pump Records (P310 to P312) .....	118
Overflow (CSO) Records (P313 to P316) .....	119
Flow Records (P320 and P321) .....	120
LCD Totalizer (P322 and P323) .....	121
Profile Records (P330 to P337) .....	122
Auto Record "on" and "off" Setpoints (P334 to P337) ...	125
Installation Records (P340 to P342) .....	127
Pump Interlock Allocation (P500 to P509) .....	128
Pump Fault Status (P510 to P515) .....	134
Pump Control Source (P520 to P524) .....	138
OCM (P600 to P621) .....	140
Pumped Volume Totalizer (P622 to P623) .....	148
Totalizer (P630 to P645) .....	150
Range Calibration (P650 to P654) .....	154
Temperature Compensation (P660 to P664) .....	157
Rate (P700 to P708) .....	159
Measurement Verification (P710 to P713) .....	162
Transducer Scanning (P726 to P728) .....	164
Display (P730 to P739) .....	166
SmartLinx Reserved (750 to 769) .....	169
Communications (P770 to P782) .....	170
SmartLinx Hardware Testing .....	175
Echo Processing (P800 to P807) .....	176
Advanced Echo Processing (P810 to P825) .....	180
Profile Pointer (P817 to P825) .....	182
Advanced TVT Adjustment (P830 to P835) .....	185
Advanced Shot Adjustment (P840 to P852) .....	188
Test (P900 to P913) .....	190
Measurement (P920 to P927) .....	193
Master Reset (P999) .....	196

<b>Appendix A – Technical Reference</b> .....	<b>197</b>
Transmit Pulse .....	197
Echo Processing .....	197
Distance Calculation .....	198
Sound Velocity .....	199
Scanning .....	199
Volume Calculation .....	200
Flow Calculation.....	201
Maximum Process Speed .....	203
<b>Appendix B – Troubleshooting</b> .....	<b>205</b>
Common Problems Chart.....	205
Noise Problems.....	206
Measurement Difficulties.....	209
Fixed Reading.....	211
Wrong Reading .....	213
Transducer Ringing.....	214
<b>Appendix C – Pump Control</b> .....	<b>215</b>
Pump Control Options.....	215
Discrete Inputs .....	216
Pump Control Algorithms .....	216
Other Pump Controls .....	221
<b>Appendix D – Discrete inputs</b> .....	<b>223</b>
Wire the Discrete Input .....	223
Program the Discrete Input Logic.....	223
Program the Interlock Logic .....	224
Test the Interlock .....	226
<b>Index</b> .....	<b>227</b>



# Introduction

---

The EnviroRanger is intended for advanced water and wastewater applications. This device can handle virtually all of your pump control and level monitoring needs – often replacing expensive PLCs and integrating into a SCADA system for a fraction of the cost of competitive systems.

## **The EnviroRanger is programmable.**

It can be configured for nearly any water or wastewater application and control up to five pumps, gates, or alarms – and can communicate its status by way of direct serial connection, modem, or industrial communication network.

## **The EnviroRanger is flexible.**

It can take discrete input from pumps or other devices and modify its operation based on that input. It can also time events to maximize efficiency or minimize cost.

## About this Manual

This is the Programming Reference manual for the Milltronics EnviroRanger integrated level monitoring and control system.

The manuals in the EnviroRanger library are:

Manual	Uses
Programming Reference (PL-556)	<ul style="list-style-type: none"><li>• Parameter values</li><li>• Parameter uses</li><li>• Programming methods</li></ul>
Installation Guide (PL-557)	<ul style="list-style-type: none"><li>• Outline diagrams</li><li>• Wiring diagrams</li><li>• Installation requirements</li></ul>
Communications Reference (PL-558)	<ul style="list-style-type: none"><li>• MODBUS register mapping</li><li>• Modem configuration</li></ul>

---

## Using this Manual

Information	Section	Page
Learn the concepts behind how the EnviroRanger operates.	About the EnviroRanger	9
Learn how to change parameter values.	Programming	15
To configure the EnviroRanger for a particular application.	Application Examples	23
To test the unit's programming before putting it into full operation..	Testing the Configuration	49
Find detailed information about any parameter.	Parameter Reference	55
Find detailed information on how the EnviroRanger uses ultrasonic technology to detect levels and convert them to usable values.	Appendix A – Technical Reference	197
If your EnviroRanger installation is experiencing problems.	Appendix B – Troubleshooting	205
To look up a concept or keyword.	Index	227



# About the EnviroRanger

---

The EnviroRanger has two modes of operation:



## Program Mode

Program mode allows the programmer to change parameter values and alter the way the unit operates.

### Note:

- If the unit has been programmed and is in normal operation then putting it in program mode will de-energize all control relay outputs. Therefore it is advisable to bypass the EnviroRanger while programming the unit to avoid overflows.
- After a programming alteration, do not use the EnviroRanger to operate alarms or controls until system programming and performance is verified.

To enter Program mode from Run mode:

1. Press the program button on the front of the device (Rack or Panel only)
2. Look for the program icon on the display (■) (Rack or Panel only)
3. Press  and then .

If the EnviroRanger is idle in Program mode for more than 5 minutes, then Run mode is automatically entered.

For information on the individual programming parameters see the chapters Application Examples on page 23 or Parameter Reference on page 55.

## Run Mode

Run mode detects material level and provides control functions. The EnviroRanger automatically starts up in the Run mode when power is applied.

To enter Run mode from Program mode, press .

“----“ is displayed briefly while the measurement reading is calculated and verified. Reading level and other data is displayed and any relays are operated based on the unit’s programming.

While the unit is in Run mode you can view system status. This information is shown on the LCD on the front of the unit or can be accessed remotely using communications software.



# Display

Wall Mount

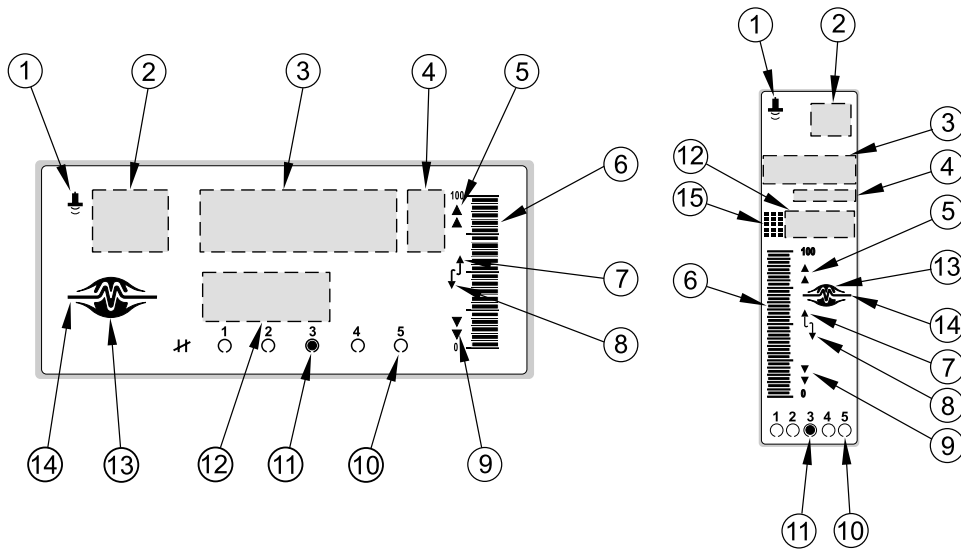
Rack or Panel Mount



About the EnviroRanger

	Program Mode	Run Mode
1	index type	index type
2	index	index
3	parameter value	primary reading
4	units	units
5	auxiliary function	hi and hi hi alarm
6	n/a	level display
7	scroll access tag	filling display
8	scroll access tag	emptying display
9	n/a	lo and lo lo alarm
10	relay # programmed flashing = unavailable	relay # programmed flashing = unavailable
11	relay # activated	relay # activated
12	parameter number	auxiliary reading
13	n/a	normal operation: 
14	n/a	failsafe operation: 
15	program mode	programming enabled

# Hand Programmer

**Note:**

The hand programmer is ordered separately from Milltronics.

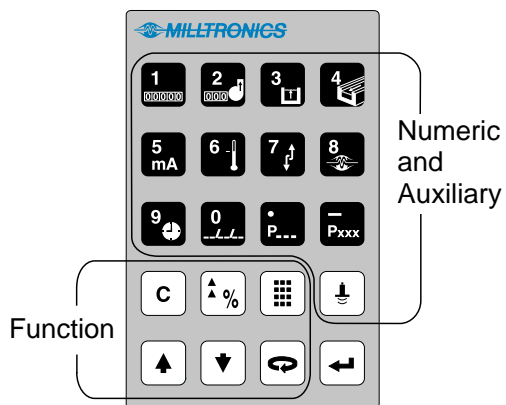

About the EnviroRanger

Key	Programming Mode	Run Mode
	1	8-digit Totalizer (toggle)
	2	Pump Running Time
	3	Head
	4	Flow based on Head
	5	
	6	Temperature
	7	Rate of Change
	8	Failsafe Time Left
	9	Time
	0	Date
	Decimal Point (TVT left)	Parameter Value
	Negative Value (TVT right)	Material Level (P731)
	Fire Transducer	Distance
	Run Mode	Program Mode (Key 1)
	Units or %	Units or % (Program Mode (Key 2))
	Next Display Field	Pause Display Toggle
	Increase Value	Next Index
	Decrease Value	Previous Index
	Enter Value	
	Clear to Preset	

# Readings in Run Mode

When the EnviroRanger is in run mode the values displayed can be changed by using keys on the hand programmer.

All readings are shown in the Auxiliary field except for the totalizer and P920.

Press this Key	Function	P#
	Toggle Readings between percent and units Level                      Space or Distance <sup>1</sup> 0 to 100%                      100 to 0%	P920
	Accumulated pump running hours <sup>2</sup> for numbered pump	P310
	Hold number key for five seconds to display the number of accumulated pump starts <sup>2</sup> for numbered pump	P311
	8-digit totalizer, uses index and reading areas, press again to toggle, P737 sets default Used for OCM and Pumped Volume.	P322, P323, P920
	Head measurement	P926
	Instantaneous flow based on head (OCM)	P925
	Temperature	P664
	Rate of level change	P707
	Failsafe Time Left (in %). When the Reading is updated, this value (Auxiliary Reading) resets to 100 and begins to decrease until the next valid measurement is made. If the Failsafe Time Left reaches 0, "LOE" flashes in the Reading display.	
	Hold for four seconds to show echo confidence	P805
	Time (hh:mm)	P009
	Date (dd:mm or mm:dd as P736)	P008
	Display the value of the entered parameter which is global or indexed by transducer	typed number
	Auxiliary reading, displays parameter specified in P731	P731
	Distance	P923

<sup>1</sup> Distances less than 0.3m (12") from the transducer face cannot be reliably measured so a 0% reading cannot be achieved during "distance" operation.

<sup>2</sup> If the associated relay is programmed for pump control.

## Scrolling Display

During “differential” or “average” Operation (P001 = 4 or 5), the display scrolls sequentially through Point Numbers 1, 2, and 3. Point Number 3 represents the difference between or average of Point Numbers 1 and 2.

See Display (P730 to P739) on page 166 for more information.



# Programming the EnviroRanger

To meet the needs of any given application the EnviroRanger must be correctly programmed. The EnviroRanger is programmed by changing parameter values. The available parameters are described in detail in the Parameter Reference on page 55 and sample applications are given in Application Examples on page 23.

## Rack or Panel Mount

To enter program mode on a rack or panel mount unit:

Press the program button on the front of the unit (shown at right)

This icon (⌘) appears when the unit can be placed in program mode.

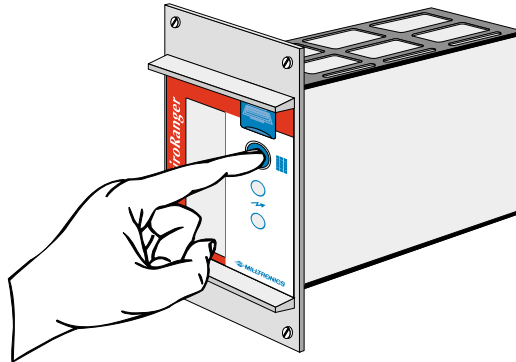

## Wall Mount

The wall mount version has no program button, it is always ready for program mode.

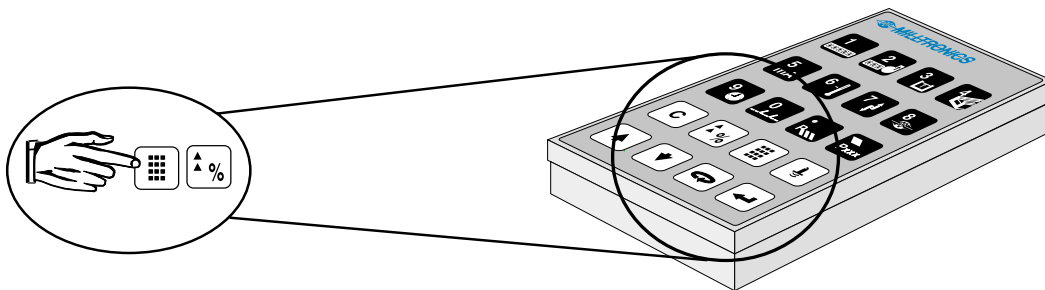

Aim the hand programmer and press the program keys on the hand programmer (shown above).

The program button allows multiple units to be installed close together and still be programmed one at a time.

Program mode is confirmed by the icon (⌘) appearing in the display. To disable programming, press again. Run mode is confirmed by absence of the icon in the display. Disable all nearby units to avoid inadvertent programming when using the infrared handheld programmer.

### Note:

Unless otherwise noted, each valid key press should produce a change in the LCD, look for this when programming the unit.

# Starting Program Mode

Entering program mode has the following effects:

- all operating data is retained in memory
- alarm relay status is held at last known values
- control relays are de-energized (unless affected by parameter alteration or  is pressed)
- discrete inputs are detected but not acted on

The Run mode is automatically re-entered if the EnviroRanger is left unattended in the program mode for an extended period (approximately 5 minutes).

## Parameter Indexing

Parameters are indexed if they can apply to more than one input or output. The index value defines to which input or output the particular parameter value relates. Indexed parameters contain a value for each index, even if that index is not used.

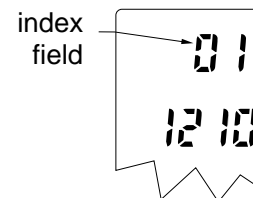

rack or panel display shown

**Note:**

To set all indexed values for a given parameter to the same value use index "0".

For example, to change the Relay Control Function (P111) for relay three you must ensure that "03" is displayed in the index field before you change the parameter value.





In this manual parameter index values are shown in brackets after the parameter number. For example P111[3] refers to parameter 111 index value 3.

**Note:**

Transducer parameters are indexed only if Operation (P001) is set to "Difference" (value=4) or "Average" (value=5). An indexed transducer is commonly referred to as a Point (short for measurement point). The term Point Number refers to indexed transducers.



To access the index of a particular parameter:

- Press  once
- Enter the parameter number
- Press  twice
- Press the number of the required index, or
- Press  or  to scroll through the available values

**Note:**

When dealing with indexed parameters it is critical to ensure that you set the values accurately. Take extra time to ensure that the correct index value is being changed for each parameter value.

## Changing Parameters (Dolphin Plus)

Programming

Tabs show groups of parameters

Parameters have roll-overs which show number

Parameters can be tracked while the EnviroRanger is running



The attached device can be programmed, debugged, and monitored from Dolphin Plus

The status bar informs you of program actions and data transfer status

Dolphin Plus is the primary method of changing EnviroRanger parameters. Most examples in this manual use the icons from the hand programmer but nearly all functions are also available through Dolphin Plus.

The Dolphin Plus software is available separately from Milltronics.

## Changing Parameters (Hand Programmer)

1. From Run mode, press  and then  to put the unit into Program mode.

**Note:**



If Parameter Value alteration is not permitted, access the Lock parameter (P000) and enter the security code, (see Programming Security).

2. Press  to select the Parameter Number field (see page 10)
3. Type the Parameter Number (e.g. 110)  
When you type the third digit the value for that parameter is shown

For lower numbered parameters, such as 007, you can type the number “7” and then press  to show that parameter.

4. Type the new value
5. Press  to enter the new value  
The EnviroRanger interprets the value and either accepts it, or replaces it with a valid value. See the Parameter Reference for descriptions of values.

The “?” icon indicates that the EnviroRanger has accepted the value but that it conflicts with other values entered. Double-check your programming.

By default the scroll keys ( or ) only show the Quick Start parameters and any that have been changed. Use P733 (G) Scroll Access on page 167 to allow all parameters to be scroll-accessed.

## Using Units or Percent (%)

Many parameters can be viewed in either measurement units (P005) or percent. View the parameter and then press the  key to toggle between units and percent. The LCD shows the current measurement type, either units (m, mm, ft, etc.) or percent (%).

# Special Parameters

## View Only

Some Parameter Values are for display purposes only and cannot be altered. These are referred to as view only parameters.

In the Parameter Reference section of this instruction manual, view only parameters are identified by a “(V)” beside the Parameter Number.

## Global

Some parameter values must be common for all inputs and outputs on the EnviroRanger. These are referred to as global parameters.

When a global parameter is accessed, the index display automatically disappears. When a non-global parameter is accessed, the index previously selected for that parameter is displayed.

In the Parameter Reference section of this manual, Global parameters are identified by a “(G)” beside the Parameter Number.

## Indexed

Some parameter values relate to indexed items. Examples of this are parameters which are different for each:

- Relay, shown with an “(IR)”
- Transducer, shown with an “(IT)”
- Discrete Input, shown with an “(IDI)”

For full descriptions of parameters and how they are indexed, see How to Read the Reference on page 55.

## Parameter Reset

To set any parameter back to the factory default:

- Display the appropriate parameter number
- Display the appropriate index value (if required)
- Press
- Press

To reset all parameters to preset values, see Master Reset (P999).



Perform a Master Reset (P999) to reset all parameters to “original” values before initial system installation, following a software upgrade, or whenever complete reprogramming is required. Use Dolphin Plus to store and retrieve parameter groups.

# Security

All operator programming is retained in non-volatile memory, immune to power interruptions. When programming is complete, the programmer may be locked away to prevent inadvertent programming alteration. As well, the Lock (P000) parameter may be used.

# Displays

The following displays are shown when the EnviroRanger cannot display a number.

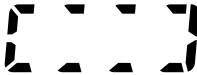
Display	Meaning
	parameter has not been set
	all values not same when viewing index 0
	parameter entered does not exist for this device

# Planning Considerations

---

## Review the Application

When reviewing the application into which the EnviroRanger will be installed, note the:

- Pump control system inputs and outputs
- Dimensions of the wet well or reservoir (especially if pumped volume will be used)
- Maximum measurement distance required (will determine transducer requirement)
- Communication type required (modem, industrial communication network)

## Design the Control Scheme

Choose the most appropriate pump control strategy from those available. See Appendix C – Pump Control on page 215 for a description of the EnviroRanger pump control strategies and options.

## Map the Control Scheme to EnviroRanger

Once the control scheme is designed, map its requirements to the EnviroRanger's parameters. Be aware of the EnviroRanger's abilities:

- Number of relay outputs (5)
- Number of discrete inputs (8)
- Number of mA inputs (1)

## Install the EnviroRanger

Mount and wire the EnviroRanger as detailed in the EnviroRanger Installation Guide (PL-557).

## Program the EnviroRanger

Use the Application Examples (page 23) and Parameter Reference (page 55) to determine the best method of programming the EnviroRanger to satisfy the control scheme.

Use either Dolphin Plus or a hand programmer to set the parameter values to those required.

## Test the Installation

Test the inputs and outputs as shown in Testing the Configuration on page 49.

## Document the Installation

Use Dolphin Plus to record your parameter values for later reference.

# Application Examples

## Note:

When the unit is first turned on it will give distance (P001=3) in meters from the transducer face to the material surface. If the wet well or reservoir is empty then this reading is the empty distance (P006) from the transducer face to the reservoir bottom. P006 is preset to 5.0m (16.4'), so reservoirs deeper than that will read LOE until P006 is updated.

## Output Limitations

The standard EnviroRanger comes with 5 relay outputs. Each relay is programmed using P111 (IR) Relay Control Function (see page 74) from a large number of options. Use these application examples as a guideline for the relay programming.

## Simple Level and Alarms

See Parameter Reference on page 55 for complete details on specific parameter values.

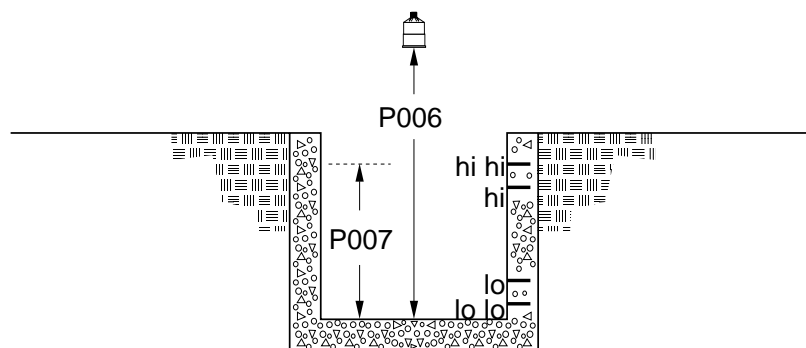

## Set the Common Parameters

**Prerequisite:** You must know the details of your application and substitute the values for the sample values provided. If you are bench testing the unit then set your test values to be the same as the sample values.

Parameter	Index	Value	Description
P001	G	1	Operation = level
P002	G	1	Material = liquid
P003	G	2	Maximum Process Speed = medium
P004	G	102	Transducer = XPS-10
P005	G	1	Units = meters
P006	G	1.8	Empty = 1.8m
P007	G	1.4	Span = 1.4m





## Setting a High High Alarm

Parameter	Relay Index	Value	Description
P111	1	1	These settings trip the alarm when the level rises above 1.2m and reset the alarm when the level falls below 1.15m.
P112	1	1.2m	
P113	1	1.15m	

## Setting a Low Alarm

Parameter	Relay Index	Value	Description
P111	3	1	These settings trip the alarm when the level falls below 0.3m and reset the alarm when the level rises above 0.4m.
P111	Aux.	L	
P112	3	0.3	The low alarm (▼) icon is displayed on the LCD when the alarm is tripped.
P113	3	0.4	

To select a Level Alarm Designation (L,LL,H,HH or blank) do the following:

1. Press  to display the Auxiliary Function symbol,
2. Press  or  as required to scroll to the alarm designation,
3. Press  to enter the value.

## Setting a Loss of Echo (LOE) Alarm

Parameter	Relay Index	Value	Description
P111	5	6	These settings trip the alarm when 0.5 minutes (30 seconds) pass without a valid echo being detected.
P070	G	0.5	

## Setting an Out of Bounds Alarm

Parameter	Relay Index	Value	Description							
P111	5	3	These settings do the following:							
P112	5	1.3		<table border="1"> <tr> <td><b>trips alarm</b></td> <td><b>resets alarm</b></td> </tr> <tr> <td>above 1.35m</td> <td>below 1.25m</td> </tr> <tr> <td>below 0.25m</td> <td>above 0.35m</td> </tr> </table>	<b>trips alarm</b>	<b>resets alarm</b>	above 1.35m	below 1.25m	below 0.25m	above 0.35m
<b>trips alarm</b>	<b>resets alarm</b>									
above 1.35m	below 1.25m									
below 0.25m	above 0.35m									
P113	5	0.3								
P116	5	0.05								



## Setting a Filling Rate Alarm

Parameter	Relay Index	Value	Description
P111	5	4	These settings trip the alarm when the reservoir is filling faster than 1m per minute and reset it at 0.9m per minute.
P112	5	1m	
P113	5	0.9m	

## Setting an Emptying Rate Alarm

Parameter	Relay Index	Value	Description
P111	5	4	These settings trip the alarm when the reservoir is emptying faster than 10% of span per minute and reset the alarm when emptying falls to 5%..
P112	5	-10%	
P113	5	-5%	

# Pump Control

See Parameters section for complete details on specific parameter values.

## Setting a Pump Down (Wet Well) Group

Sets a group of three pumps to pump down a wet well.

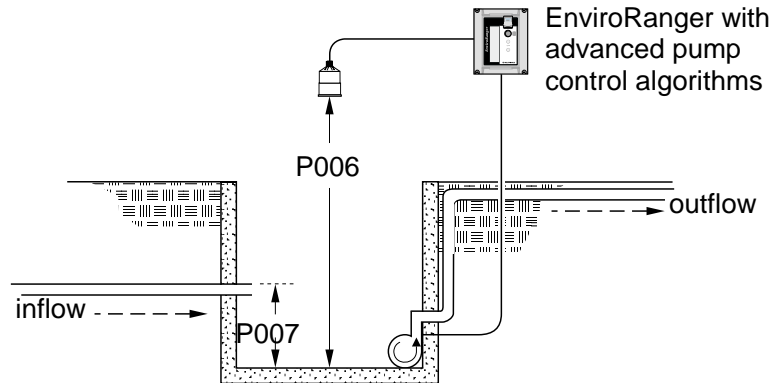

## Set the Common Parameters

**Prerequisite:** You must know the details of your application and substitute the values for the sample values provided. If you are bench testing the unit then set your test values to be the same as the sample values.

Parameter	Index	Value	Description
P001	G	1	Operation = level
P002	G	1	Material = liquid
P003	G	2	Maximum Process Speed = medium
P004	G	102	Transducer = XPS-10
P005	G	1	Units = meters
P006	G	1.8	Empty = 1.8m
P007	G	1.4	Span = 1.4m

## Set the Pump Relays to “Alternate duty assist”

Parameter	Relay Index	Value	Description
P111	1	52	Sets the pump relays (index 1, 2, and 3) to “alternate duty assist”.
P111	2	52	
P111	3	52	

## Set the “On” Setpoints

Parameter	Relay Index	Value	Description
P112	1	1.0m	Sets the three setpoints for the pump relays. The first cycle will use these setpoints. Subsequent cycles rotate the setpoints among the pumps.
P112	2	1.1m	
P112	3	1.2m	

## Set the “Off” Setpoints

Parameter	Relay Index	Value	Description
P113	0	0.5m	By using index 0 all five relays are set at the same time, <b>including any alarm relays</b> . Use index 0 with caution.

## Optional: Starting Pumps by Rate of Level Change

Parameter	Relay Index	Value	Description
P112	1	1.35	Starting pumps by rate allows all setpoints to be set higher to save money by pumping from the highest safe level of the wet well.
P112	2	1.35	
P112	3	1.35	
P113	1	0.5m	Notice that all indexed relays for both P112 and P113 are set to the same levels.
P113	2	0.5m	
P113	3	0.5m	
P121	1	1	The pumps will start on 20 second intervals until the rate set in P703 is met.
P121	2	1	
P121	3	1	
P132	G	20.0	

## Optional: Rotating Pumps by Service Ratio

**Prerequisite:** the pump relays must be set to a “service ratio” value (P111 = 54 or 55).



Parameter	Relay Index	Value	Description
P122	1	1	These values will start pump 2 50% of the time and pumps 1 and 3 25% of the time each.
P122	2	2	
P122	3	1	

## Optional: Totalizing Pumped Volume

Prerequisite: the volume of the wet well or reservoir must be known.

Parameter	Index	Value	Description
P001	G	7	Operation = pumped volume
P002	G	1	These parameters are “as above.”
P003	G	2	
P004	G	102	
P005	G	1	
P006	G	1.8	
P007	G	1.4	
P050	G	1	
P051	G	17.6	Max volume is 17.6 m <sup>3</sup> or 17,600 liters
P111	1	52	Sets relays 1, 2, and 3 as a pump group using Alternate Duty Assist control.
P111	2	52	
P111	3	52	
P112	1	1.0	Sets the “on” setpoints for the pump group.
P112	2	1.2	
P112	3	1.4	
P113	0	0.2	Sets the “off” setpoints for all relays.

### Run Mode

- Press  to enter Run mode.
- Press  to display the pumped volume on the totalizer.
- Press  to display the current level in the auxiliary reading area.

## Other Optional Functions

Function	Page	Description
Independent Failsafe	90	Overrides default per relay
Pump Run-on	91	Pumps past “off” setpoint
Pump Start Delay	92	Staggers pump starts
Power Resumption Delay	92	Delays first pump start
Pump Exercising	93	Pumps based on time
Wall Cling Reduction	93	Randomizes setpoints
Pump Group	94	Separates pump groups
Pump Energy Saving	95	Pumps during low cost periods
Overflow Handling	99	Reaction to overflow events
Flush Systems	103	Controls a flush device
Pump Efficiency Testing	105	Removes poor performing pumps

## Setting a Pump Up (Reservoir) Group

Sets a group of three pumps to pump up a reservoir.

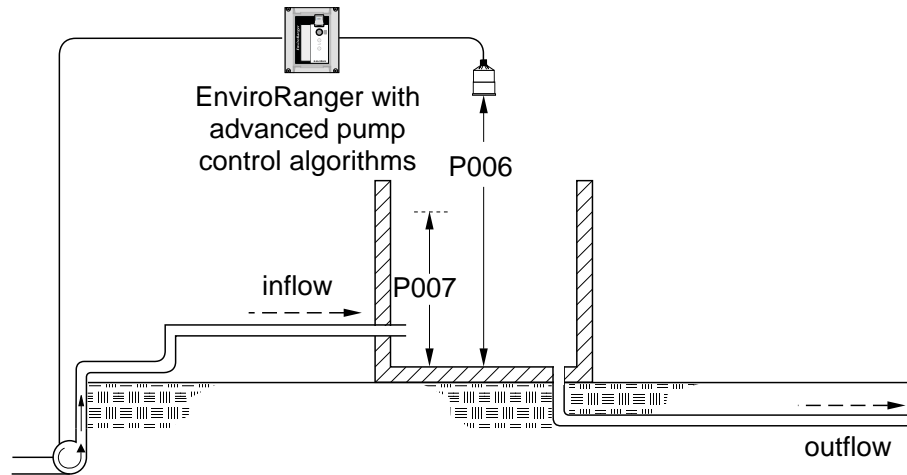

## Set the Common Parameters

**Prerequisite:** You must know the details of your application and substitute the values for the sample values provided. If you are bench testing the unit then set your test values to be the same as the sample values.

Parameter	Index	Value	Description
P001	G	1	Operation = level
P002	G	1	Material = liquid
P003	G	2	Maximum Process Speed = medium
P004	G	102	Transducer = XPS-10
P005	G	1	Units = meters
P006	G	1.8	Empty = 1.8m
P007	G	1.4	Span = 1.4m

## Set the Pump Relays to “Alternate Duty assist”

Parameter	Relay Index	Value	Description
P111	1	52	Sets the pump relays (index 1, 2, and 3) to “alternate duty assist”.
P111	2	52	
P111	3	52	

## Set the Relay “On” Setpoints

Parameter	Relay Index	Value	Description
P112	1	0.4m	Sets the three setpoints for the pump relays. The first cycle will use these setpoints. Subsequent cycles rotate the setpoints among the pumps.
P112	2	0.3m	
P112	3	0.2m	

## Set the Relay “Off” Setpoints

Parameter	Relay Index	Value	Description
P113	0	1.3m	By using index 0 all relays are set to the same value.

**Note:**

Optional parameters found on page 28.

## Connecting a Pump Control Interlock

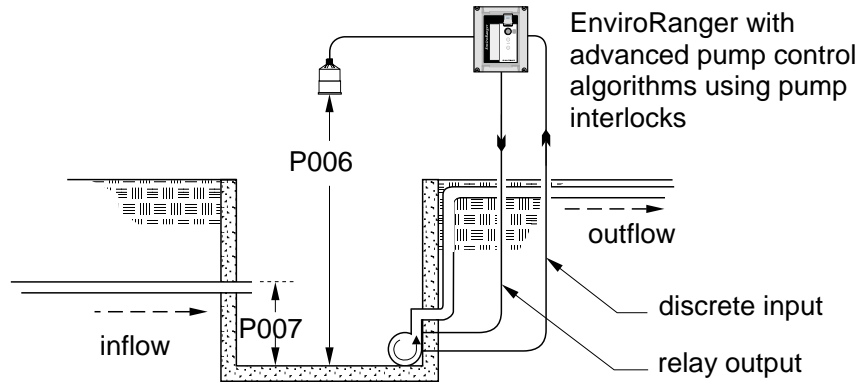

Parameter	Relay Index	Value	Description
P111	1	52	Sets the pump relays (index 1, 2, and 3) to "alternate duty assist".
P111	2	52	
P111	3	52	
P505	1	3	Sets discrete inputs 3, 4, and 5 as the inputs for the pumps attached to relays 1, 2, and 3 respectively.
P505	2	4	
P505	3	5	

These values will ensure that any pump reporting a failure is removed from the pumping rotation. For more information on pump interlocks and discrete inputs see:

- Discrete Input Functions (P270 to P275) on page 110
- Pump Interlock Allocation (P500 to P509) on page 128
- Appendix C – Pump Control on page 215

# Open Channel Monitoring (OCM)

See Parameters section for complete details on specific parameter values.

There are three ways of defining an OCM installation depending on your Primary Measuring Device (PMD). See the listed examples for required parameters.

- **Dimensional**  
is provided for some common weir and flume types. For these PMDs the dimensions (P602) are entered directly.
- **Exponential**  
is provided for most other weir and flume types. For these PMDs the exponent provided by the manufacturer is entered. Flow is calculated using the exponent (P601) and the maximum values (P603 and P604).
- **Universal**  
is provided to accommodate any installation not covered by the first two types. For all other PMDs the head-to-flow curve can be plotted and approximated based on known breakpoints, usually supplied by the PMD manufacturer.

## Dimensional (P600=2,3,6,7)

- BS-3680 / ISO 1438/1 Thin plate V notch weir on page 35
- BS-3680 / ISO 4359 Rectangular Flume on page 36
- Palmer Bowlus Flume on page 37
- H Flume on page 38

## Exponential (P600=1)

- Standard Weirs on page 39
- Parshall Flume on page 40
- Leopold Lagco on page 41
- Cut Throat Flume on page 42

## Universal (P600=4,5)

- Typical Flow Characterization on page 42
- Example Flumes on page 43
- Example Weirs on page 43



## Set the Common Parameters

These “Quick Start” parameters are required for all installations.

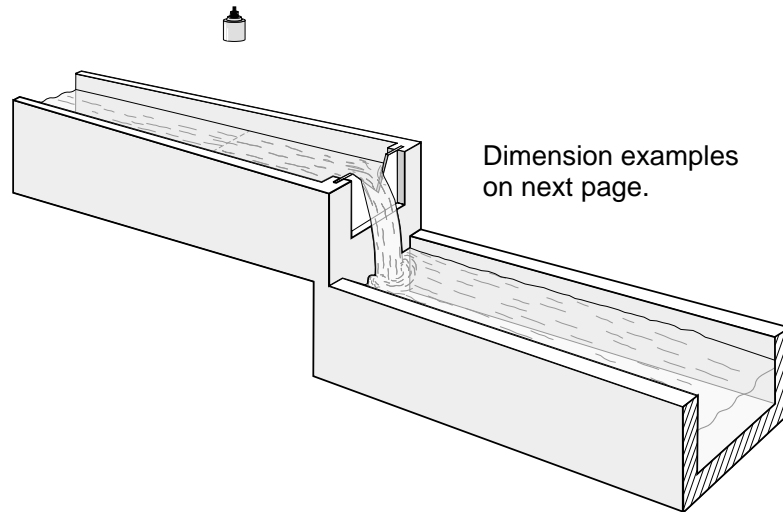

Parameter	Index	Value	Description
P001	G	6	Operation = OCM
P002	G	1	Material = liquid
P003	G	2	Maximum Process Speed = medium
P004	G	102	Transducer = XPS-10
P005	G	1	Units = meters
P006	G	1.8	Empty = 1.8m
P007	G	1.0	Span = 1.4m
P801	G	0.8	Range Extension to avoid “LOE”

## Setting Zero Head

Many PMDs trap a pool of liquid when there is no flow. There are two methods of accounting for this trapped liquid:

1. Use P605 Zero Head to raise the start of Span (P007) above the Empty distance (P006). See P605 (G) Zero Head on page 143.

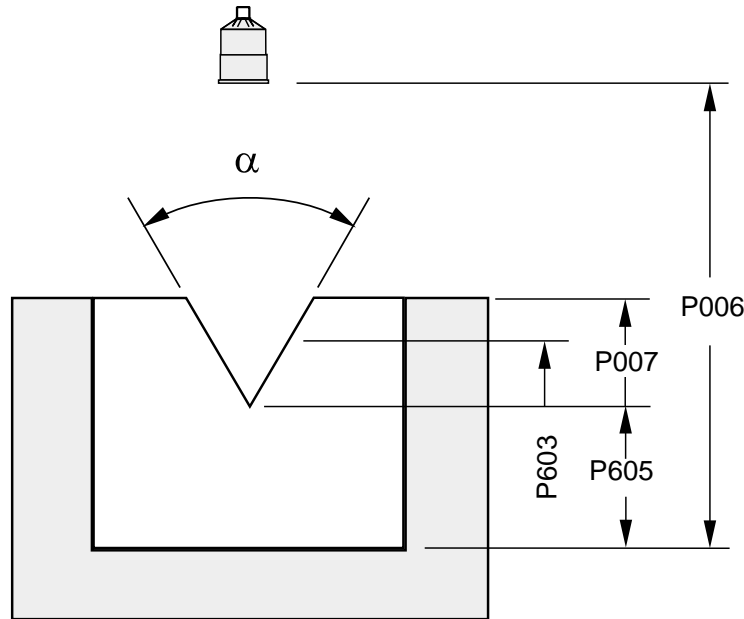

2. Use P801 Range Extension to ignore readings below the artificially-short Empty distance (P006). See P801 (G) Range Extension on page 176.

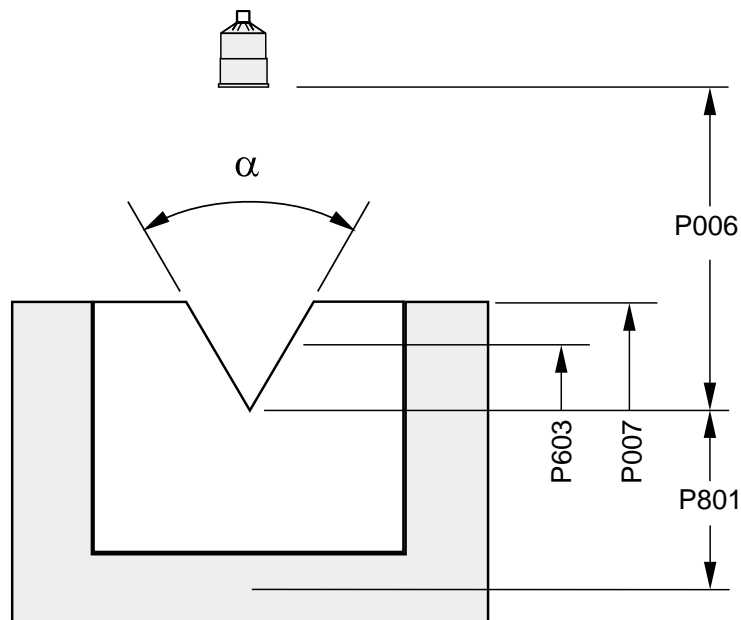

The examples on the following pages show both methods.

## Setting Totalized Volume

To display the totalized volume on the LCD use the following parameters:

Parameter	Index	Value	Description
P737	G	2	Show the eight digit totalizer in the primary display

## Direct Support

### BS-3680 / ISO 1438/1 Thin plate V notch weir

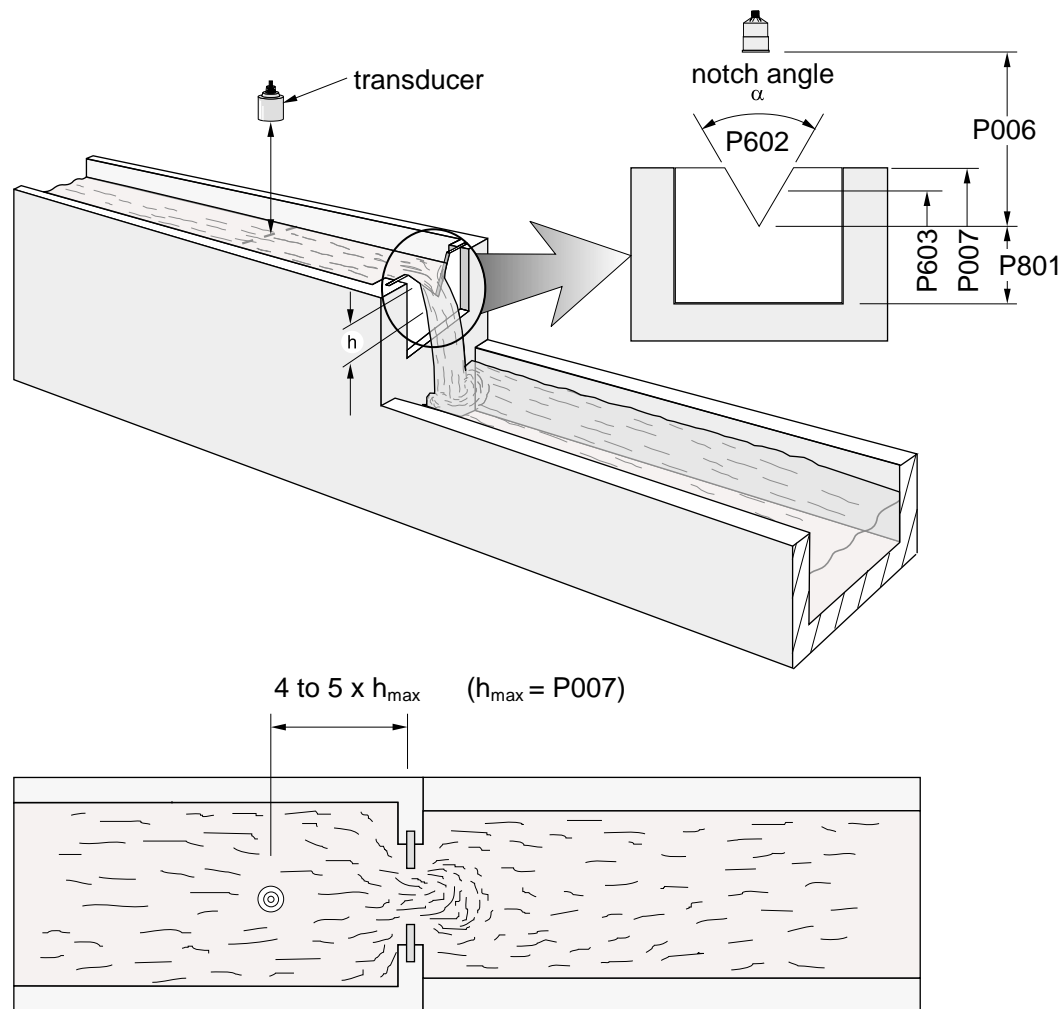

Parameter	Index	Value
P600	G	7 – ISO 1438/1 V Notch Weir
P602	1	Notch angle
(view only)	2	Discharge coefficient ( $C_e$ )
P603	G	Maximum Head (preset to P007)
P801	G	Range Extension
P608	G	Flowrate Units

# BS-3680 / ISO 4359 Rectangular Flume

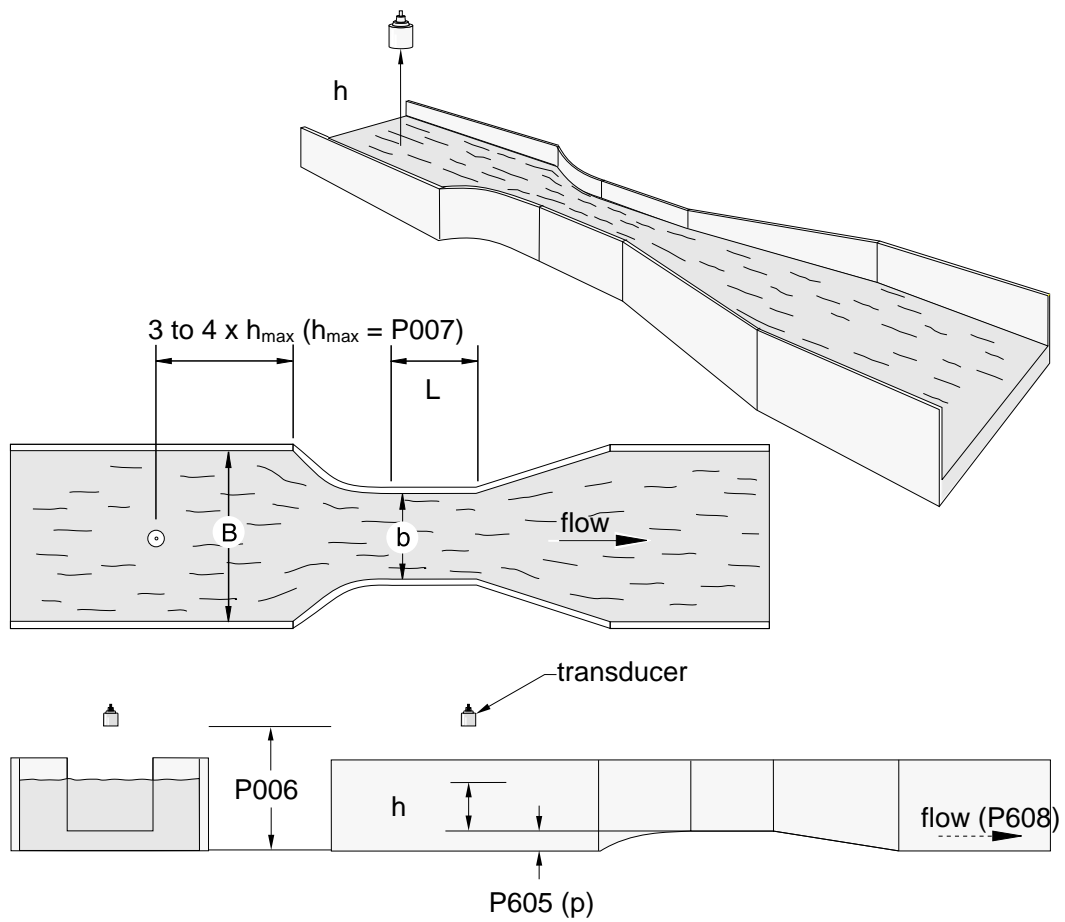

Parameter	Index	Value
P600	G	6 – ISO 4359 Rectangular Flume
P602	1	Approach width (B)
	2	Throat width (b)
	3	Hump Height (p)
	4	Throat length (L)
(view only)	5	Velocity coefficient (Cv)
(view only)	6	Discharge coefficient (Cd)
(view only)	7	Cross sectional area
P605	G	Zero Head
P608	G	Flowrate Units

## Palmer Bowlus Flume

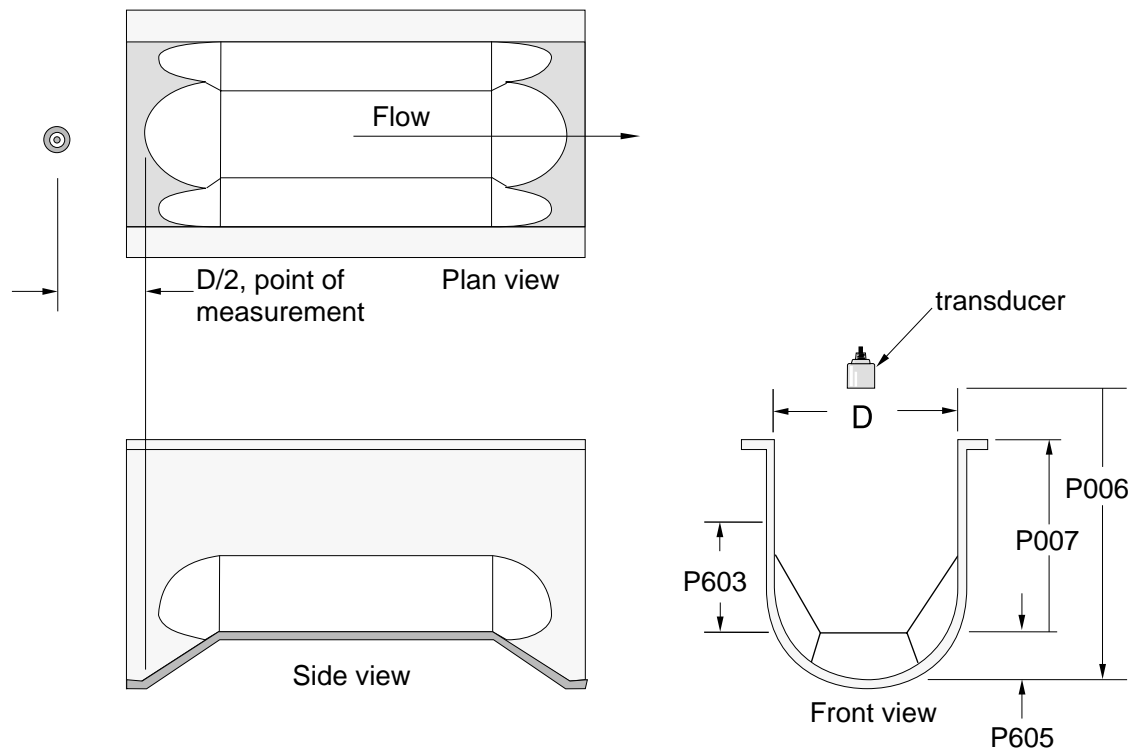

Parameter	Index	Value
P600	G	2 – Palmer Bowlus Flume
P602	1	Flume width (D)
P603	G	Maximum Head (preset = P007)
P604	G	Maximum Flow
P605	G	Zero Head
P606	G	Time Units

- Sized by pipe diameter, D
- Flume relief is trapezoidal
- Designed to install directly into pipelines and manholes
- Head is referenced to bottom of the throat, not bottom of the pipe
- For rated flows under free flow conditions, the head is measured at a distance of D/2 upstream from the beginning of the converging section

## H Flume

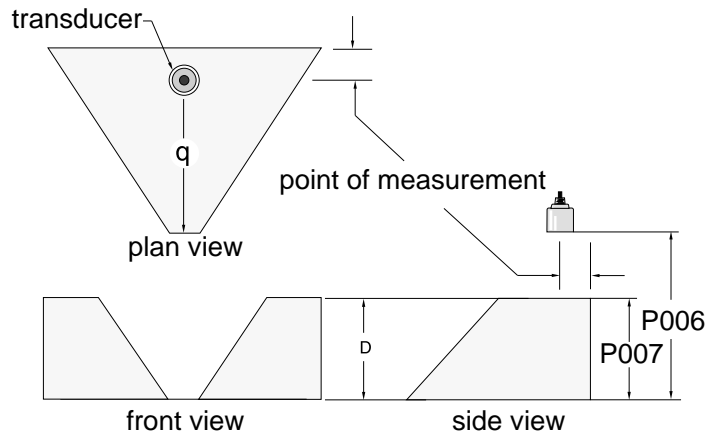

Parameter	Index	Value
P600	G	3 – H Flume
P602	1	Flume height (D)
P603	G	Maximum Head (preset = P007)
P604	G	Maximum Flow
P606	G	Time Units

- Sized by maximum depth of flume, D
- Approach is preferably rectangular, matching width and depth for distance 3 to 5 times the depth of the flume
- May be installed in channels under partial submergence (ratio of downstream level to head). Typical errors are:
  - 1% @ 30% submergence
  - 3% @ 50% submergence
- For rated flows under free flow conditions, the head is measured at a point downstream from the flume entrance

Flume Size (D in feet)	Point of Measurement	
	cm	inches
0.5	5	1¾
0.75	7	2¾
1.0	9	3¾
1.5	14	5½
2.0	18	7¼
2.5	23	9
3.0	28	10¾
4.5	41	16¼

- H flumes come with a flat or sloping floor. The same flow table can be used as error is less than 1%.

# PMDs with Exponential Flow to Head Function

For Primary Measuring Devices (PMDs) that measure flow by an exponential equation use these parameters. Ensure that you use the correct exponent for your PMD, the values below are samples only.

## Standard Weirs

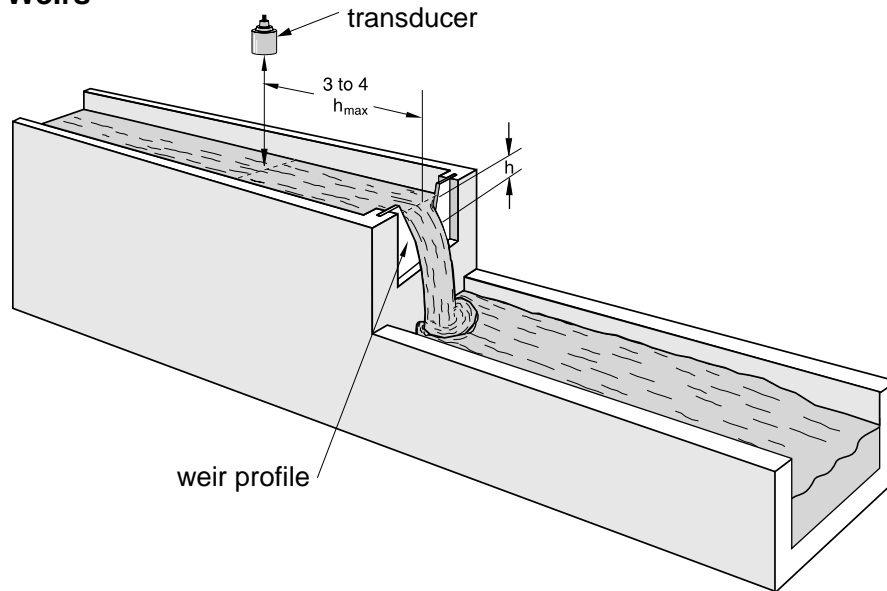

## Applicable Weir Profiles

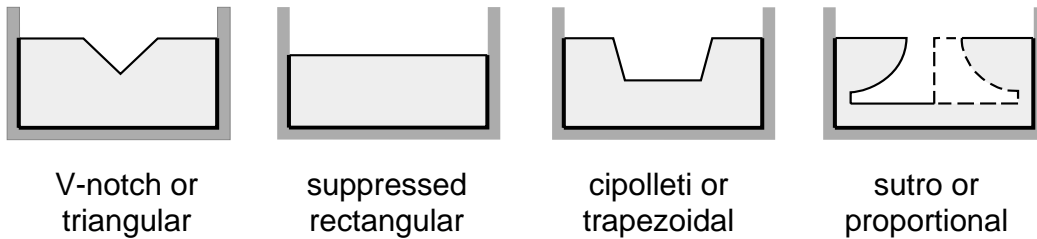

Parameter	Index	Value	
P600	G	1 – Exponential Function	
P601	G	<b>Weir Type</b>	
		<b>Value<sup>†</sup></b>	
		V-notch	2.50
		Suppressed rectangular	1.50
		Cipolletti or trapezoidal	1.50
		Sutro or proportional	1.00
P603	G	Maximum Head	
P604	G	Maximum Flow	
P606	G	Time Units	
P801	G	Range Extension	

† These values are samples only. Consult your weir manufacturer's documentation for the correct flow exponent.

## Non-Applicable Weir Profiles

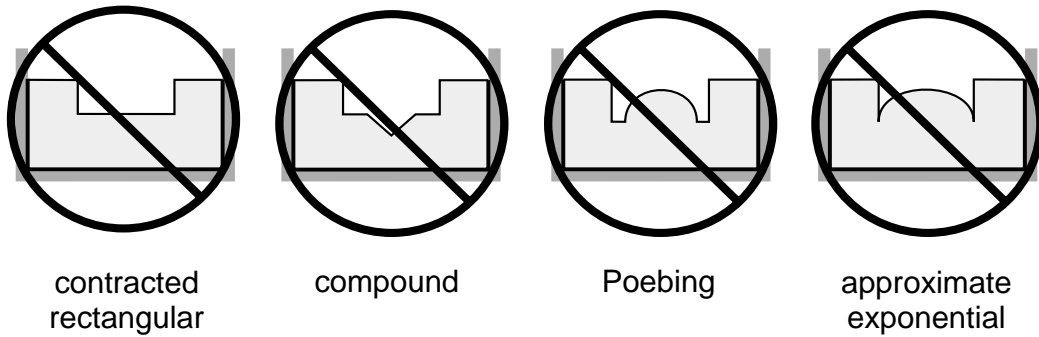

Flows through these weirs can be measured using the universal flow calculation  $P600 = 4$  or  $5$ . See Universal Calculation Support on page 42.

## Parshall Flume

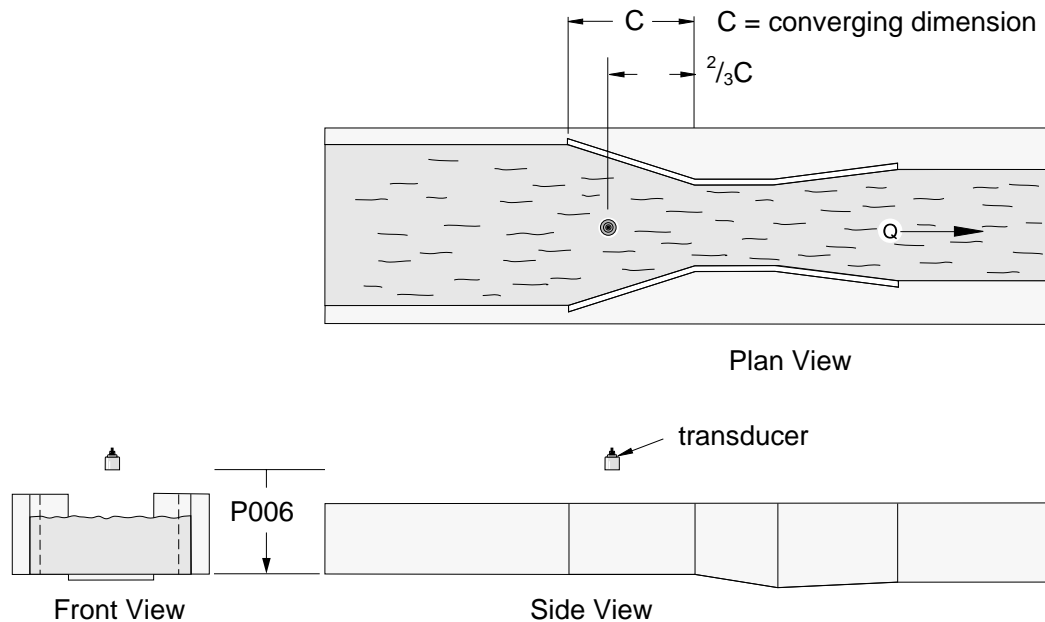

- sized by throat width
- set on solid foundation
- For rated flows under free flow conditions the head is measured at  $\frac{2}{3}$  the length of the converging section from the beginning of the throat section.

Parameter	Index	Value
P600	G	1 – Parshall Flume
P601	G	1.22 – 1.607 (consult your flume documentation)
P603	G	Maximum Head
P604	G	Maximum Flow (Q)
P606	G	Time Units



## Leopold Lagco Flume

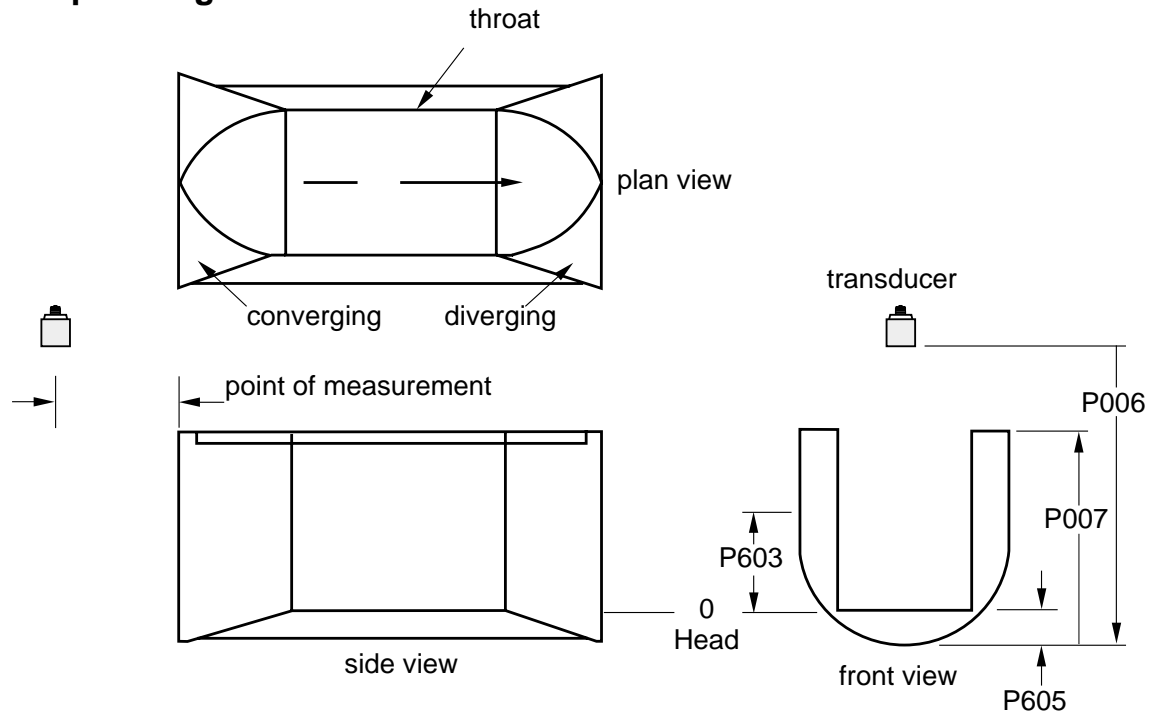

Parameter	Index	Value
P600	G	1 – Leopold Lagco Flume
P601	G	1.55
P603	G	Maximum Head (preset P007)
P604	G	Maximum Flow
P605	G	Zero Head
P606	G	Time Units

- Designed to be installed directly into pipelines and manholes
- Leopold Lagco may be classed as a rectangular Palmer-Bowlus flume
- Sized by pipe (sewer) diameter
- For rated flows under free flow conditions the head is measured at a point upstream referenced to the beginning of the converging section. Refer to the following table:

Flume Size (pipe diameter in inches)	Point of Measurement	
	cm	inches
4-12	2.5	1
15	3.2	1¼
18	4.4	1¾
21	5.1	2
24	6.4	2½
30	7.6	3
42	8.9	3½
48	10.2	4
54	11.4	4½
60	12.7	5
66	14.0	5½
72	15.2	6

## Cut Throat Flume

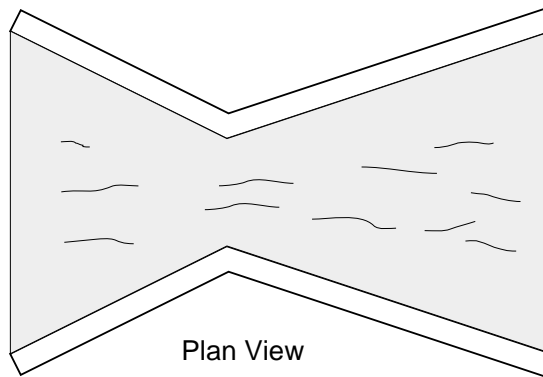

- Similar to Parshall flume except that the floor is flat bottomed and throat has no virtual length.
- Refer to manufacturer's specifications for flow equation and point of head measurement.

Parameter	Index	Value
P600	G	1 – Cut Throat Flume
P601	G	1.55
P603	G	Maximum Head (preset P007)
P604	G	Maximum Flow
P606	G	Time Units

## Universal Calculation Support

When the primary measuring device (PMD) doesn't fit one of the standard types it can be programmed using a universal characterization. When Universal is selected as the PMD type (P600) then both P610 and P611 must be entered to define the flow.

Two curve types are supported:

- P600 = 4 – linear (piecewise linear)
- P600 = 5 – curved (cubic spline)

Both are shown in the following chart:

## Typical Flow Characterization

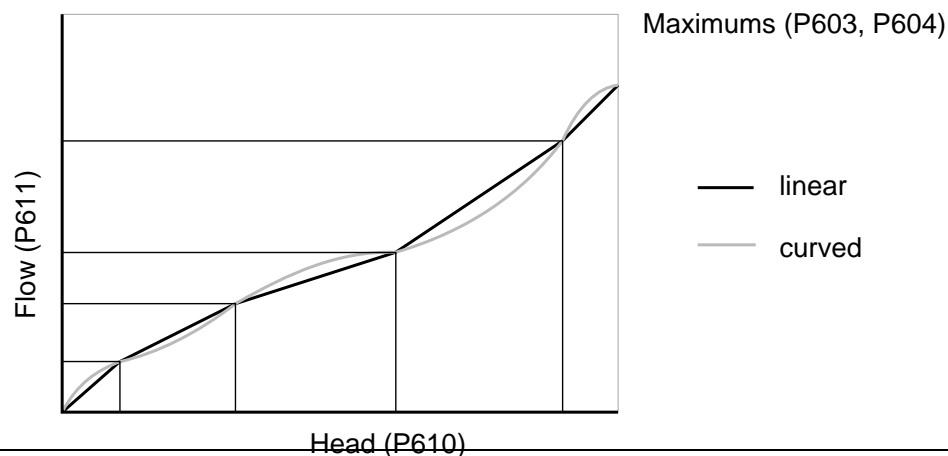

Characterization is achieved by entering the head (P610) and corresponding flow (P611), either from empirical measurement or from the manufacturer's specification. The more breakpoints that are defined, the more accurate will be the flow measurement. Breakpoints should be concentrated in areas exhibiting the higher degrees of non linear flow. A maximum of 32 breakpoints can be defined. The curve's end point is always specified by the parameters Maximum Head (P603) and Maximum Flow (P604) for a maximum total of 33 breakpoints.

Use as many breakpoints as required by the complexity of your PMD.

See Flow Calculation on page 201 for more information.

## Example Flumes

These example flumes would both require a universal calculation.

### Trapezoidal

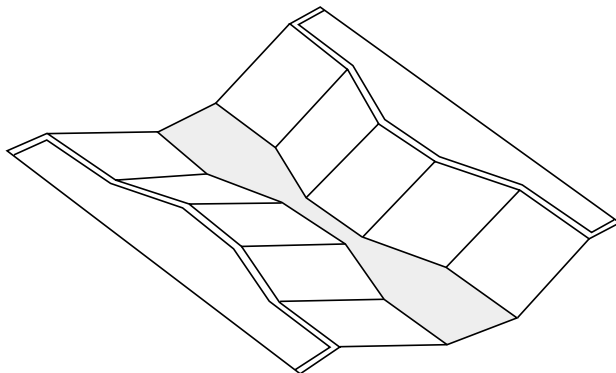

### Dual Range (nested) Parshall

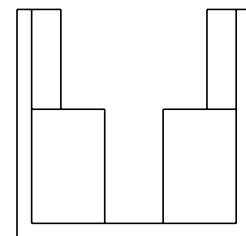
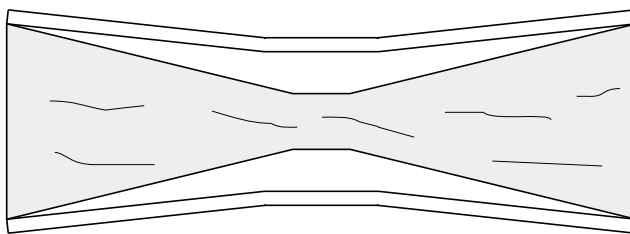

## Example Weirs

These weirs could require universal calculation.

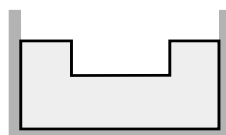

contracted  
rectangular

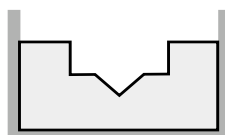

compound

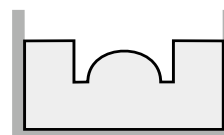

Poebing

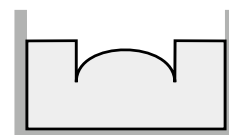

approximate  
exponential

For further information regarding universal flow calculations, see Flow Calculation on page 201.

# Gate Control

See Parameters section for complete details on specific parameter values. This technique can also be applied to some types of valves.

## Setting a Gate (Penstock) Control

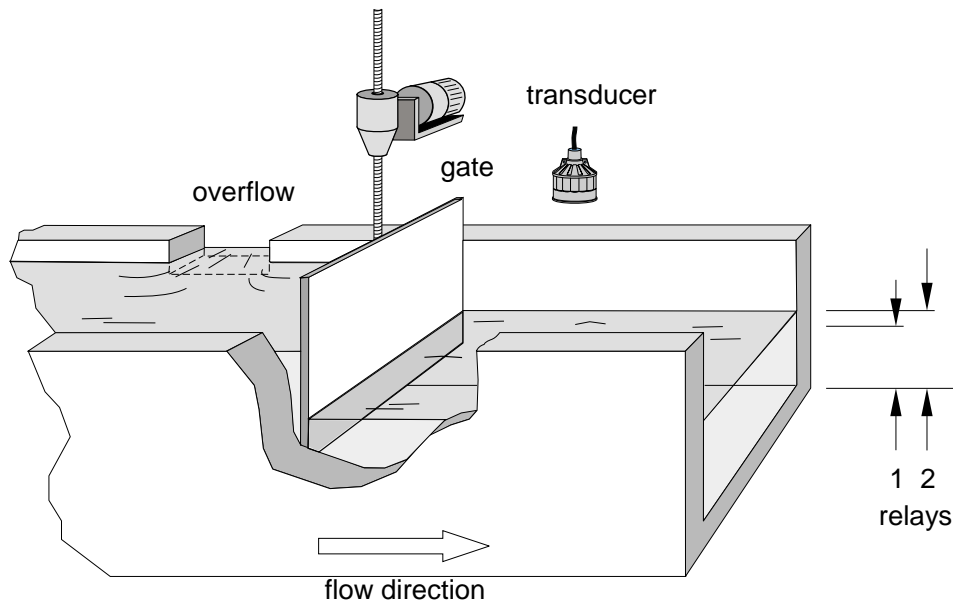

## Set the Common Parameters

**Prerequisite:** You must know the details of your application and substitute the values for the sample values provided. If you are bench testing the unit then set your test values to be the same as the sample values.

Parameter	Index	Value	Description
P001	G	1	Operation = Level
P002	G	1	Material = liquid
P003	G	2	Maximum Process Speed = medium
P004	G	102	Transducer = XPS-10
P005	G	1	Units = meters
P006	G	1.8	Empty = 1.8m
P007	G	1.4	Span = 1.4m

## Set Relay 1 (Open Gate)

Relay 1 is wired to the “open” connections on the gate control. When relay 1 is energized the gate moves up.

Parameter	Index	Value	Description
P111	1	63	Sets relay 1 to energize (open gate)
P112	1	45%	when the level is below 45% of the span (0.63m). The gate will open for 0.1
P113	1	----	minute (6 seconds) and this cycle will
P114	1	0.1	happen once per 0.02 hours (1 minute,
P115	1	0.02	12 seconds) until the level is above 45%

## Set Relay 2 (Close Gate)

Relay 2 is wired to the “close” connections on the gate control. When relay 2 is energized the gate moves down.

Parameter	Index	Value	Description
P111	2	63	Sets relay 2 to energize (close gate)
P112	2	55%	when the level is above 55% of the span (0.77m). The timing (P114, P115) of
P113	2	----	relay 2 is set from the relay 1 setpoints.

### Note:

Care must be taken to adjust P114 and P115 for proper proportional integral (PI) control without overshoot or cycling. P114 is equivalent to proportional band (P). P115 is equivalent to reset (I).

The transducer can also be placed upstream from the gate to control upstream head.

# Rake (Screen) Control

Screens or rakes are mounted on the inflow channel of the wastewater treatment plant to prevent debris from clogging the equipment. When material builds up on the screen a level differential is created with the water level higher in front of the screen than behind it. When this differential reaches the programmed setpoint the EnviroRanger activates a relay to run mechanical rakes to clean the screen and ensure a steady flow into the treatment process.

## Setting a Rake Control

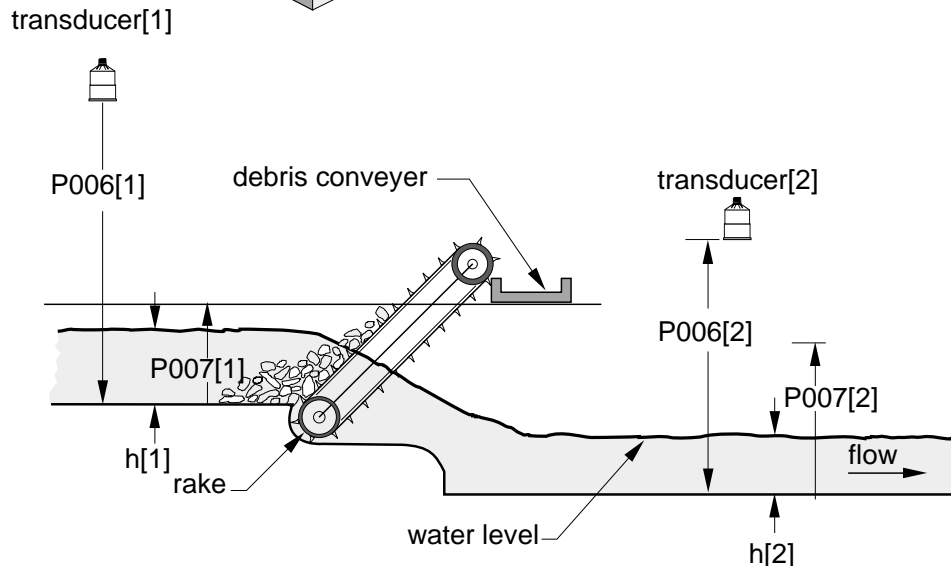
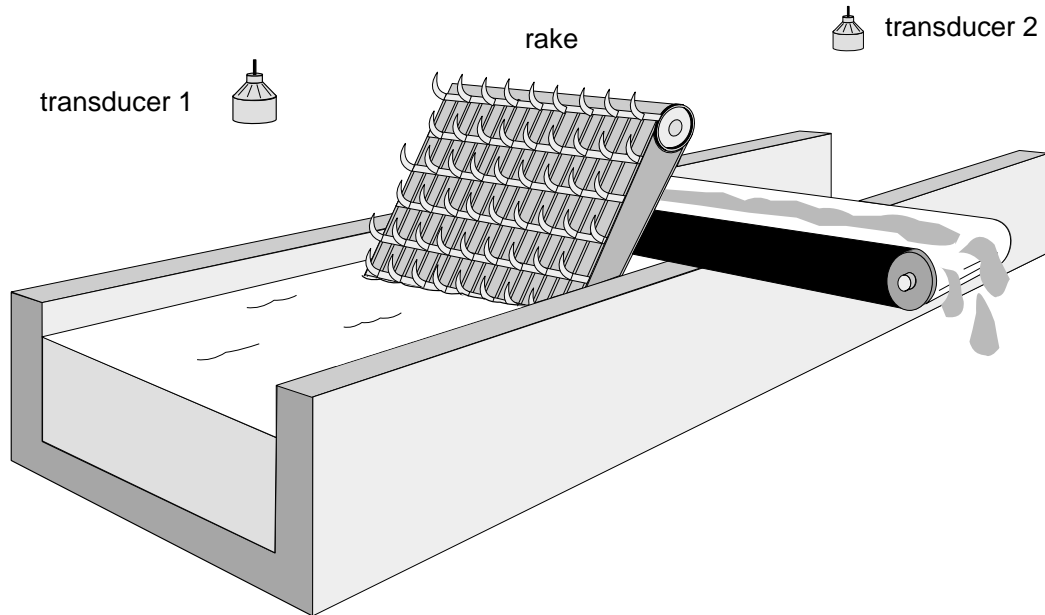

$$\text{Level difference (point 3)} = h[1] - h[2]$$

## Setting the Common Parameters

**Prerequisite:** You must know the details of your application and substitute the values for the sample values provided. If you are bench testing the unit then set your test values to be the same as the sample values.

Parameter	Index	Value	Description
P001	G	4	Operation = Differential
P002	G	1	Material = liquid
P003	1,2	2	Maximum Process Speed = medium
P004	1,2	102	Transducer = XPS-10
P005	G	1	Units = meters
P006	1	1.8	Empty = 1.8m
	2	2.2	Empty = 2.2m
P007	1	1.4	Span = 1.4m
	2	1.4	Span = 1.4m

## Set Relay 1 (Operate Rake)

Parameter	Index	Value	Description
P110	1	3	Starts the rake when the difference between the two levels rises above 0.4m and stop the rake when the difference falls below 0.1m.
P111	1	50	
P112	1	0.4	
P113	1	0.1	

## Set Relays 2 to 4 (Level Alarms)

Parameter	Index	Value	Description
P110	2	1	Sets relay 2 as a high level alarm for transducer 1 with an “on” setpoint of 1.3m and an “off” setpoint of 1.2m.
P111	2	1	
P112	2	1.3	
P113	2	1.2	
P110	3	2	Sets relay 3 as a low level alarm for transducer 2 with an “on” setpoint of 0.2m and an “off” setpoint of 0.4m.
P111	3	1	
P112	3	0.2	
P113	3	0.4	
P110	4	3	Sets relay 4 as a “rake failure” alarm as it uses the differential level point (3) with an “on” setpoint of 1.0m and an “off” setpoint of 0.9m.
P111	4	1	
P112	4	1.0	
P113	4	0.9	





# Testing the Configuration

---

Once you've programmed the EnviroRanger you must test the device to ensure that it performs to your specifications. This test can be run in simulation mode or by varying the level in the wet well. The latter is preferred as it more accurately represents running conditions. However, if it is not possible to do a physical test, the simulation mode will ensure that all control programming is correct.

## Simulation

When in simulation mode the LCD shows the EnviroRanger's reaction to level changes but any pump or control relays are held off. Alarm relays are allowed to operate based on the simulation.

To allow pump or control relays to operate based on the simulated level, set P000 to -1.



## Simulating a Single Measurement

Access the appropriate parameter (Press  and then Enter the parameter number).

Press ; repeat 5 times to overcome Echo Lock (P711), if applicable. The associated Reading is displayed in the Parameter Value field, and any "alarm" relays are set accordingly.

To verify Reading calculations (P920 to P926)...

1. Key in a material level in Units (P005) or % of Span (P007).
2. Press , the calculated Reading is displayed.
3. Verify the calculated Reading.









To start a simulation from the level entered, press  or .

## Simulating a Level Cycle

To start a (P920, P921, P922, or P923) simulation (from level = 0)...

Press  to simulate level rise and fall at 1% of Span / second.

Use the  and  keys to adjust the simulated rate of rise or fall.

	Rise at 4% of Span per second (maximum)
 	Rise at 1 % of Span per second (preset at start of simulation)
 	Stopped
 	Fall at 1% of Span per second
	Fall at 4% of Span per second (maximum)

When the level rises to 100% or falls to 0% it reverses direction at the same rate.

## Checking Volume Characterization

To check that the universal volume calculations (P050 = 9, 10) are accurate do the following:

1. Go to P920
2. Enter a level with a known volume
3. Press Enter
4. Check the returned volume against the manufacturer's chart
5. Change parameters P054 and P055, as required
6. Repeat steps 2 to 5 until the volume curve is verified

## Checking OCM Flow Characterization

To check that the universal flow calculations (P600 = 4, 5) are accurate do the following:

1. Go to P925
2. Enter a level with a known flow
3. Press Enter
4. Check the returned volume against the manufacturer's chart
5. Change parameters P610 and P611, as required
6. Repeat steps 2 to 5 until the flow curve is verified

## I/O Checkout

Once the EnviroRanger is installed a test is usually performed to verify the wiring.

## Relays

Use P119 (IR) Relay Logic Test (page 87) to force a state change and verify that the results are as expected (pump starts, alarm sounds, etc.).

## Discrete Inputs

Use P270 to force the input value and verify that the results are as expected (pump removed from rotation, overflow event, etc.).

1. Go to P270[n] where n = the discrete input to be tested
2. Set to 0 to force the input off
3. Go to P275[n] to verify that the value is forced
4. Check the state of outputs to ensure that they respond as expected
5. Go to P270[n]
6. Set to 1 to force the input on
7. Go to P275[n] to verify that the value is forced
8. Check the state of outputs to ensure that they respond as expected

For further information see:

- Discrete Input Functions (P270 to P275) on page 111
- Overflow / Underflow (P160 to P169) on page 99
- Pump Interlock Allocation (P500 to P509) on page 128
- Pump Fault Status (P510 to P515) on page 134
- Pump Control Source (P520 to P524) on page 138
- Discrete Inputs (for pump control algorithms) on page 216

## mA Input

Use P254 to test the mA input value against a true level. Use a trusted external mA source to generate the signal required for testing and verify the incoming signal with P260. As the mA level is changed ensure that the system responds as expected.

## Reset for Run Mode

Once testing is complete and the unit is ready for operation it is good practice to clear any pump interlocks. Do this by setting P510[0] to 0.

## Application Test

If the application is being tested by varying the material level (preferred) then ensure that none of the control devices are connected (or at least there is no power available to them).

If the application is being tested in simulation mode (and P000 is not -1) then control relays are not energized and they can remain connected.

While the level is being cycled, check the results of the discrete inputs by either closing the circuit externally (preferred) or using P270 (IDI) Discrete Input Function on page 111 to force the input on or off. Try all possible combinations to thoroughly test the setup. For each combination run a complete cycle to verify that the pumps operate as expected.

Monitor system performance carefully, under all anticipated operating conditions.

1. When the EnviroRanger performs exactly as required, programming is complete.
2. If alternate Reading units, failsafe action, or relay operation is desired, update the parameters for the new functionality.
3. If the system performance experiences problems, see Appendix B – Troubleshooting on page 205.

If all operating conditions cannot be observed during the System Performance Evaluation, refer to Measurement (P920 to P927) on page 193 for simulation instructions. Perform a Reading Measurement simulation to verify programming.

Usually, when a simulation is run, alarm relays will energize based on programming but control relays will not.

Conduct a System Performance Evaluation following any installation modification or programming (parameter) alteration.

## Programming Documentation

With programming complete, record all parameter alterations.

1. If the keypad programmer is used, enter the program mode and scroll to altered parameters (skipping parameters left at preset values). Record all parameter alterations.
2. If Dolphin Plus software is used, save a file to disk. If you require hardcopy use the Dolphin Plus Reports feature to print either the full list or only those parameters changed from factory default.

For normal operation, return to the Run mode. The EnviroRanger will perform reliably, requiring little or no maintenance.

Connect (or enable) process control/alarm equipment to the EnviroRanger only after satisfactory performance is verified for all possible operating conditions.



# Parameter Reference

---

## How to Read the Reference

Each item in the programming reference has five sections:

### Title

The number, type and name of the parameter.

Possible types are:

Type	Name	Description
G	Global	This parameter applies to the entire unit
V	View only	This parameter can not be set, only viewed
IT	Transducer	Indexed by transducer (if P001=4 or 5)
IL	Level Point <sup>3</sup>	Indexed by level point (if P001=4 or 5))
IR	Relay	Indexed by relay (5)
IDI	Discrete Input	Indexed by discrete input (8)
IP	Comm. Port	Indexed by communications port (2)
ID	Dimension	Indexed by PMD dimension (up to 6)
IE	Echo Profile	Indexed by stored echo profile (10)
IB	Breakpoint	Indexed by breakpoint (10 or 32)
IC	CSO Log	Indexed by CSO log entry (20)

### Description

*The first, italic, paragraph describes the purpose of the parameter, when you would change it, and for which applications.*

### Details

The following paragraphs detail the parameter and include any side-effects of using it.

### Values or Choices

The table shows the possible values in units or numbered choices for the parameter with short descriptions. **The preset is marked with an asterisk (\*) or listed as a value.**

### Related

A listing of any related parameters.

---

<sup>3</sup> The three level points are: transducer 1, transducer 2, and the calculated point which can be difference (P001=4) or average (P001=5).

## P000 (G) Lock

*Use this parameter to secure the EnviroRanger from changes.*

### WARNING

**Use this lock as backup security only. It uses a fixed value which can be discovered by unauthorized personnel.**

Access this parameter directly (type the number 000) and enter any value (other than 1954) to secure the programming lock. To unlock the EnviroRanger, access this parameter and enter the value "1954".

When lock is activated, the EnviroRanger may be switched from the RUN mode to the program mode and the value of any parameter may be viewed but not altered.

Normally, during a measurement simulation (see Measurement Parameters, P920 - P926), pump or control relays remain de-energized. If desired, set Lock for "simulation controls" to have pump or control relays function based on the simulated level.

Simulation mode reverts to 1954 after the unit is idle for 10 minutes.

Simulate using P920 usually does not energize control relays. If this parameter is set to -1 then all relays will energize when the P920 simulation is run.

### Values

1954	*	off (programming permitted)
-1		simulation controls (relays energize based on simulated level)
other		lock activated (programming secured)

### Related

- P132 (G) Pump Start Delay on page 92
- Simulation on page 49



# Quick Start (P001 to P009)

## P001 (G) Operation

*Sets the type of measurement required for the application.*

If 0 – “out-of-service” is entered alarm relay(s) energize (set “off”), and pump relay(s) de-energize (set “off”).

If “DPD” or “DPA” is entered, either 2 transducers of the same type are required, or one transducer and one mA input. If two transducers are used all transducer parameters become indexed, and a third level point is calculated:

- $DPD \text{ (difference)} = \text{Point 1} - \text{Point 2}$
- $DPA \text{ (average)} = (\text{Point 1} + \text{Point 2}) / 2$

For these operations any of three level points (transducer 1, transducer 2, or the calculated point) can be used to trigger relays (see P110 (IR) Level Source on page 74).

### Values

0	Out-of-service
1	Level – how full the vessel is (a.k.a. volume – P050)
2	Space – how empty the vessel is (a.k.a. ullage – P050)
3	* Distance – distance from transducer to material
4	DPD – dual point difference
5	DPA – dual point average
6	OCM – flow rate in an open channel
7	Pump Totalizer – total pumped volume

## P002 (G) Material

*The type of material being measured, normally liquid.*

For most EnviroRanger applications this entry will be liquid or slurry (value 1) but the application could also involve solids.

### Values

1	* Liquid or horizontal solid surface
2	Solid or angled surface

## P003 (IT) Maximum Process Speed

*Determines how quickly the EnviroRanger reacts to level changes.*

Use the setting which is just fast enough to keep up with your process. Slower settings provide higher accuracy while faster settings allow for more level fluctuations.

### Values

1		Slow (0.1 m/min)
2	*	Medium (1 m/min)
3		Fast (10 m/min)

### Related

- Failsafe (P070 to P072) on page 69
- P121 (G) Pump by Rate on page 88
- Measurement Verification (P710 to P713) on page 162
- Transducer Scanning (P726 to P728) on page 164
- Rate (P700 to P708) on page 159

## P004 (G) Transducer

*Specifies the Milltronics transducer connected.*

Enter the type of transducer(s) connected to the EnviroRanger. If multiple transducers are used they must be of the same type.

### Values

0		No transducer attached
1		ST-25
2		ST-50
100		STH
101		XCT-8
102	*	XPS-10
103		XCT-12
104		XPS-15
112		XRS-5
250		Auxiliary (see mA Input)

### Related

- mA Input (P250 to P254) on page 108

## P005 (G) Units

*Specifies the units used for dimensional values.*

Changing this value automatically changes the units displayed for all parameters. Existing values are converted and do not have to be re-entered.

### Values

- |   |   |             |
|---|---|-------------|
| 1 | * | Meters      |
| 2 |   | Centimeters |
| 3 |   | Millimeters |
| 4 |   | Feet        |
| 5 |   | Inches      |

### Related

- P060 (IT) Decimal Position on page 66

## P006 (IT) Empty

*The distance in “units” from the face of the transducer to the process empty point.*

Setting this value also sets Span (P007) unless Span was already set to another value.

### Values

0.000 to 9999  
Preset: 5.000m (or equivalent depending on units)

### Related

- P007 (IT) Span on page 60
- P800 (G) Near Blanking on page 176

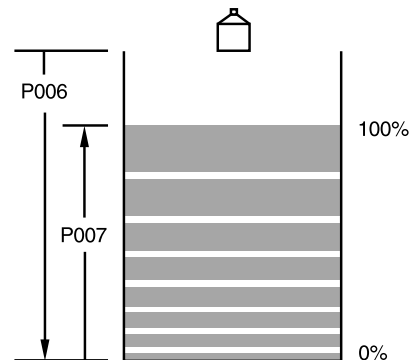

## P007 (IT) Span

*Span is the range of levels that the equipment is set to measure.*

Span is preset for a value close to the maximum available. Enter a value that reflects the maximum range of your application.

Always prevent the monitored surface from approaching within 0.33 m (1 ft) of the transducer face as this is the minimum blanking for most Milltronics transducers (some require more blanking – see your transducer manual).

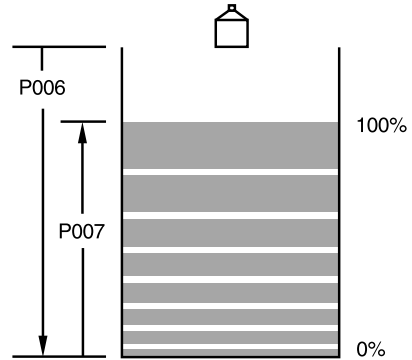

Many other parameters are set as a percentage of span (even if they are entered in units). The values of these other parameters may change if the span is altered after installation and they are measured based on level (upwards from Empty towards the transducer face).

All volumes are based on span so it should be set for the maximum volume point if volume calculations are needed.

### Values

0.0 to 9999

Preset: based on Empty (P006)

### Related

- P800 (G) Near Blanking on page 176
- P006 (IT) Empty on page 59
- P005 (G) Units on page 59
- Volume (P050 to P055) on page 62
- P112 (IR) Relay “on” Setpoint on page 84
- P113 (IR) Relay “off” Setpoint on page 84

## P008 (G) Date

*Date is the current date in the format: YY.MM.DD.*

The date is entered by using the numeric keypad and the decimal “.” key. For example, to enter December 10, 1998 you would type in the value “98.12.10”.



rack or panel display shown

## Year 2000 Compliance

00-69	Assumed to be the years 2000 to 2069
70-99	Assumed to be the years 1970 to 1999

### Values

70:01:01 to 69:12:31

## P009 (G) Time

*Time is the current time in 24-hour format: HH.MM.SS.*

The time is entered using the numeric keypad and the decimal “.” key. For example, to enter 9:34:45 p.m. you would type in the value “21.34.45”.

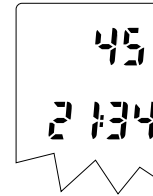

rack or panel  
display shown

### Values

00:00:00 to 23:59:59

Parameter Reference

## Volume (P050 to P055)

To enable the EnviroRanger to show readings based on vessel or wet well volume (rather than level) use these parameters.

If one of the “universal” tank shapes is used then follow this procedure:

- Plot a volume to height chart
- Enter the curve values from this chart into P054 and P055
- Ensure extra points are added around sharp transitions in the chart/reservoir

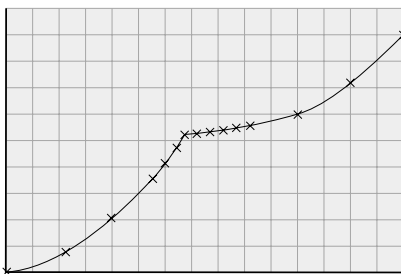

If you require volume display only (based on linear multiplication of span) then use P061 (IT) Convert Reading on page 66. This method does not calculate volume and must not be used in place of these parameters if any volume dependent features (such as pump efficiency) are used.

### P050 (G) Tank Shape

*Enter the Tank Shape value that matches the monitored vessel or wet well.*

When Operation is "level" (P001 = 1), liquid (material) volume is calculated. Alternatively, when Operation is "space" (P001 = 2), remaining vessel capacity is calculated.

In the RUN mode, Readings are displayed in percent maximum volume. To convert Readings to volumetric units, see Max Volume (P051).

## Values

0 = volume calculation not required (preset)

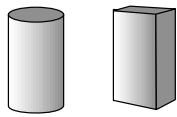

1 = flat level bottom

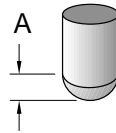

4 = half sphere bottom

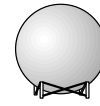

8 = sphere

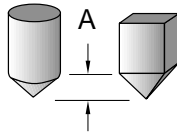

2 = cone / pyramid bottom

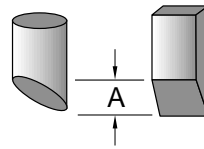

5 = flat sloped bottom

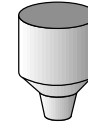

9 = universal linear

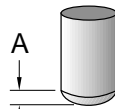

3 = parabola bottom



6 = flat ends



10 = universal curved

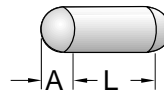

7 = parabola ends

## Related

- P051 (G) Max Volume on page 63
- Pump Efficiency (P180 to P186) on page 105
- P001 (G) Operation on page 57
- Pumped Volume Totalizer (P622 to P623) on page 148
- P920 (IL) Reading Measurement on page 193

## P051 (G) Max Volume

*For Readings in volumetric units (rather than percent), enter the vessel volume between Empty (P006) and Span (P007).*

The units of measurement for this reading are arbitrary. The volume is calculated from the empty position to the maximum span position and is scaled according to the Tank Shape (P050) value. This enables the use of any volume units required.

### Note:

Ensure that the chosen units allow the total volume to be displayed in the four digits on the LCD.

## Example

1. If max. volume =  $3650 \text{ m}^3$ , enter 3650.
2. If max. volume = 267500 gallons, enter 267.5 (1000's of gallons).

**Values**

0.0 to 9999  
Preset: 100.0

**Related**

- P006 (IT) Empty on page 59
- P007 (IT) Span on page 60
- P060 (IT) Decimal Position on page 66

**P052 (G) Tank Dimension 'A'**

*This is dimension 'A' as used in P050 (G) Tank Shape on page 62.*

Enter the height of the tank bottom if P050 = 2,3,4, or 5, or the length of one end section of the tank if P050 = 7, in Units (P005).

**Values**

0.000 to 9999  
Preset: 0.000

**P053 (G) Tank Dimension 'L'**

*This is dimension 'L' as used in P050 (G) Tank Shape on page 62.*

Enter the tank length (excluding both end sections) if P050 = 7.

**Values**

0.000 to 9999  
Preset: 0.000

**P054 (IB) Breakpoint Levels (Universal Volume Calculation)**

*When the tank shape is too complex for any of the preconfigured shapes you can specify the volume based on segments.*

Enter up to 10 level breakpoints (where volume is known) if P050 = 9 or 10.

These values should be provided by the tank manufacturer.

**To enter a Level Breakpoint...**

1. Go to Parameter P054
2. For each index enter a breakpoint in measurement units
3. Ensure that each breakpoint corresponds to the same index for P055

**Values**

0.000 to 9999



## P055 (IB) Volume Breakpoints (Universal Volume Calculation)

Each segment defined by the level breakpoints (P055) requires a volume to allow the EnviroRanger to make the level-to-volume calculations.

These values should be provided by the tank manufacturer.

Some typical volume calculations are:

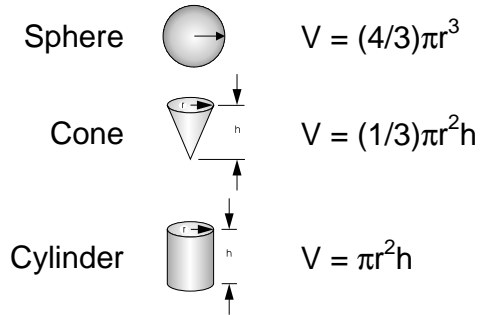

Enter the volume corresponding to each Level Breakpoint entered.

### To enter a Volume Breakpoint...

1. Go to Parameter P055
2. For each index enter a volume
3. Ensure that each volume corresponds to the same index for P054

### Values

0.0 to 9999

Preset: 0.000

# Display and Reading (P060 to P062)

Alter the following parameters to:

- Change the number of decimal places displayed
- Convert the Reading to alternate units
- Reference measurements to other than Empty (P006) or Span (P007)

## P060 (IT) Decimal Position

*Defines the maximum number of decimal places used on the LCD.*

In the RUN mode, the number of decimal places displayed is automatically adjusted (if necessary) to prevent the number of digits from exceeding the display capabilities (4 digits). To keep the decimal place from shifting, and make reading the display easier, reduce the number of decimal places to the number shown at 100%.

For example, if 100% equals 15 metres then use two decimal places to allow for readings such as 15.00 or 12.15.

This value is automatically altered when Units (P005) or Max Volume (P051) is altered.

### Values

- |   |   |   |
|---|---|---|
| 0 |   | no digits after the decimal point                               |
| 1 |   | 1 digit after the decimal point                                 |
| 2 | * | 2 digits after the decimal point                                |
| 3 |   | 3 digits after the decimal point (limited by device resolution) |

### Related

- P005 (G) Units on page 59
- P051 (G) Max Volume on page 63
- P920 (IL) Reading Measurement on page 193

## P061 (IT) Convert Reading

*Multiplies the current value by the specified amount to allow for any scaling required.*

### Examples:

- If the measured value is in feet enter 0.3 to display the number of yards
- For simple linear volume conversions you can enter the volume measurement per unit to get the correct conversion. For example, if the reservoir contains 100 litres per vertical meter, use 100 to get the reading in liters.

This method does not calculate volume and must not be used in place of the volume parameters if any volume dependent features (such as pump efficiency) are used. To calculate true volumes see Volume (P050 to P055) on page 62.

Avoid entering a value that, when multiplied by the maximum current Reading, could exceed five digits before the Decimal Position or the device will not display the value correctly.

If a value does exceed five digits then the value “EEEE” is displayed.

### Values

-999 to 9999

Preset: 1.000

### Related

- P920 (IL) Reading Measurement on page 193

## P062 (IT) Offset Reading

*Adds the specified value to the level reading, usually to reference the reading to sea level or another datum level.*

The operation of the device is not affected by the Offset Reading. This value is used for display purposes only. All control measurements are still referenced to Empty.

### Example

To reference the displayed level to sea level, enter the distance in Units (P005), between Empty (P006) and sea level. (Enter a negative value if Empty is below sea level.)

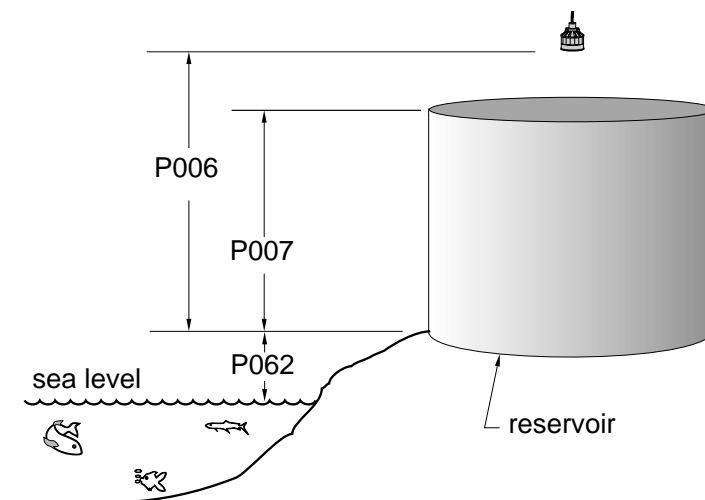

### Values

-999 to 9999

Preset: 0.000

**Related**

- P920 (IL) Reading Measurement on page 193

## Failsafe (P070 to P072)

The failsafe parameters are used to ensure that if no valid level reading is available then the devices controlled by the EnviroRanger default to an appropriate state.

By default, if an error condition is detected then the display and relay status are held at their last "known" values and the Failsafe Timer (see below) is activated. If the Failsafe Timer expires and the unit is still in an error condition then P071 (IT) Failsafe Material Level determines the level reading.

Control the reaction of the EnviroRanger to extended error conditions by configuring parameter P071 (IT) Failsafe Material Level, described on page 70, and ensure that the fail state is optimal for your application.

If Failsafe Operation activates frequently, see Appendix B – Troubleshooting on page 205.

### P070 (G) Failsafe Timer

*The time elapsed, in minutes, of invalid measurements before Failsafe State is activated.*

Once activated, the Failsafe state initiates the following:

1. P071 (IT) Failsafe Material Level (described on page 70) is activated as the material level reading.
  - a. The unit responds to the new level as programmed (control and alarm relays activate as defined by the programming)
  - b. Individual relays can have independent failsafe responses. See P129 (IR) Relay Failsafe on page 90.
2. The appropriate error is displayed:
  - a. **LOE** for loss of echo from the transducer
  - b. **Short** for a shorted transducer cable
  - c. **Open** for a cut transducer cable
  - d. **Error** for all other problems

When modifying the preset value, use one that is short enough to protect the process but long enough to avoid false alarms. Use 0 (no delay) only for testing purposes.

This value is automatically altered when P003 (IT) Maximum Process Speed (page 58) is altered.

**Values**

0.000 to 9999  
 Preset: 10.00 minutes

**Related**

- P003 (IT) Maximum Process Speed on page 58
- P129 (IR) Relay Failsafe on page 90

**P071 (IT) Failsafe Material Level**





*The material level reported when a Failsafe State is initiated.*

There are four possible settings for this parameter:

<b>HOLD</b>	Keep the last known material level
<b>HI</b>	Use the full Span (P007) as the material level
<b>LO</b>	Use Empty (P006) as the material level
<b>Measurement</b>	Use an arbitrary value (between 0 and 150% of span)

Select the Failsafe Material Level based upon the relay operation required during failsafe operation.

**Selecting HI, LO, or HOLD**

1. Press  to display the Auxiliary Function symbol,
2. Press  or  as required to scroll to the desired option,
3. Press  to enter the value.

**Entering a Measurement**

To enter a specific Failsafe Material Level within -50 to 150% of Span (P007), in Units (P005) or % of Span.

**Relay reaction**

The way in which relay programming reacts to the failsafe level depends on P129 (IR) Relay Failsafe (page 90 ). By default:

- Alarm relays have P129 = “OFF” and so react to the Failsafe Material Level.
- Control relays (all pumps and some others) have P129 = “dE” and so de-energize the relay when the unit enters Failsafe mode regardless of the Failsafe Material Level.

**Values**

0.000 to 9999	Value in units or % (to 150% of span)
HI	Level goes to maximum span
LO	Level goes to 0 span (Empty)
HOLD	* Level remains at last reading

**Related**

- P001 (G) Operation on page 57
- P006 (IT) Empty on page 59
- P007 (IT) Span on page 60
- P111 (IR) Relay Control Function on page 74
- P112 (IR) Relay “on” Setpoint on page 84
- P113 (IR) Relay “off” Setpoint on page 84
- P129 (IR) Relay Failsafe on page 90

**P072 (IT) Failsafe Level Advance**

*The speed at which the EnviroRanger advances to and returns from the Failsafe Material Level.*

When "Restricted" (preset), the EnviroRanger advances to/from the Failsafe Material Level, as determined by Maximum Process Speed (P003) or the Max Fill / Empty Rate (P700/P701) values entered.

When "Immediate" is selected, the Failsafe Material Level is assumed immediately.

When "Fast Back" is selected, the Failsafe Level Advance is restricted, however the return to a new measured material level is immediate.

**Values**

1	*	Restricted
2		Immediate
3		Fast Back

**Related**

- P003 (IT) on page 58
- P700 (G) Max Fill Rate on page 159
- P701 (G) Max Empty Rate on page 159
- P070 (G) Failsafe Timer on page 69
- P071 (IT) Failsafe Material Level on page 70

# Relays (P100 to P119)

The EnviroRanger comes with five relays, sometimes called digital outputs, typically used to control devices and alarms. While the number of devices directly controlled is limited by the relays all control functions are accessible through software. Refer to the EnviroRanger Communications Reference for information on accessing information through software.

Each parameter is indexed to the five relays. See Special Parameters on page 19 for more information.

## Preset Applications (P100)

The EnviroRanger makes standard applications easier to program by providing an extensive list of presets.

## Control Functions (P111)

Each relay can be configured independently to take advantage of the flexibility built into the EnviroRanger. Configure the relays independently to take advantage of the advanced features of the EnviroRanger. Start with a preset application and then change only the required parameters to make the task more efficient.

## Setpoints (P112, P113, P114, P115)

Each relay is triggered by one or more setpoints. The setpoints can be based on absolute level (P112, P113), rate of change (P702, P703), or time (P114, P115). Each different control function specifies which setpoints are required.

## P100 (G) Preset Applications

*There are six preset applications which can help configure the EnviroRanger for typical use or for bench testing before commissioning.*

If your application is similar to those listed here then select the appropriate one and then change only the parameters required. If none of these preset applications suits your needs then move on to P111 (IR) Relay Control Function on page 74.

**Note:**

Programming the relays independently is the most common method used.

For screen applications (P100=5) the EnviroRanger's operation must be set to difference (P001=4).

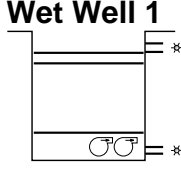
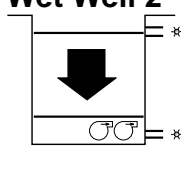
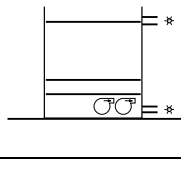
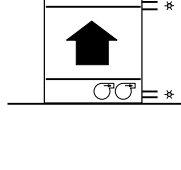
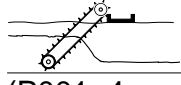
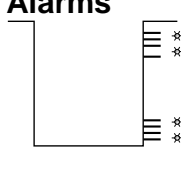

## Parameters Affected by Pre-set Applications

Value	#	Parameters affected					
Off	0	All relays set "off"					
<b>Wet Well 1</b> 	1	Pump down with the following level settings:					
		Parameter	Relay #				
			1	2	3	4	5
		P111	52	52	1 (H)	1 (L)	0
		P112	70%	80%	90%	10%	–
P113	20%	20%	85%	15%	–		
<b>Wet Well 2</b> 	2	Pump down with the following level and rate settings:					
		Parameter	Relay #				
			1	2	3	4	5
		P111	52	52	1 (H)	1 (L)	0
		P112	80%	80%	90%	10%	–
		P113	20%	20%	85%	15%	–
P121	1						
Because the pumps are started by rate you must change P702 and P703 to appropriate values.							
<b>Reservoir 1</b> 	3	Pump up with the following level settings:					
		Parameter	Relay #				
			1	2	3	4	5
		P111	52	52	1 (H)	1 (L)	0
		P112	30%	20%	90%	10%	–
P113	80%	80%	85%	15%	–		
<b>Reservoir 2</b> 	4	Pump up with the following level and rate settings:					
		Parameter	Relay #				
			1	2	3	4	5
		P111	52	52	1 (H)	1 (L)	0
		P112	20%	20%	90%	10%	–
		P113	80%	80%	85%	15%	–
P121	1						
Because the pumps are started by rate you must change P702 and P703 to appropriate values.							
<b>Screen</b>  (P001=4 only)	5	Differential control of a screen or rake:					
		Parameter	Relay #				
			1	2	3	4	5
		P110	3	1	2	3	0
		P111	50	1 (H)	1 (L)	1 (H)	–
P112	80%	90%	10%	90%	–		
P113	20%	85%	15%	10%	–		
<b>Alarms</b> 	6	General alarms at four setpoints:					
		Parameter	Relay #				
			1	2	3	4	5
		P111	1 (H)	1 (L)	1 (HH)	1 (LL)	0
P112	80%	20%	90%	10%	–		
P113	75%	25%	85%	15%	–		

Parameter Reference

## P110 (IR) Level Source

*The level source on which the indexed relay matches setpoints.*

This value is reset if Relay Set Up (P100) is altered. Points 2 and 3 are available only if Operation is set for difference or average (P001 = 4 or 5).

### Values

- 1 \* Point # 1 = transducer 1
- 2 Point # 2 = transducer 2
- 3 Point # 3 = difference (P001=4) or average (P001=5)

### Related

- P001 (G) Operation on page 57

## P111 (IR) Relay Control Function

*The control algorithm used to trip the relay.*

Use 0 (preset) to disable control of the indexed relay.

Complete table of values on next page.

## Values

Control	Type	# <sup>4</sup>	Relay Control
General	Off	0	Relay set off, no action
Alarm page 76	Level	1	based on level setpoints “on” and “off”
	In Bounds	2	when level enters the range between “on” and “off” setpoints
	Out of Bounds	3	when level exits the range between “on” and “off” setpoints
	Rate of Change	4	based on rate setpoints “on” and “off”
	Temperature	5	based on temperature setpoints “on” and “off”
	Loss of Echo (LOE)	6	when echo is lost
	Cable Fault	7	when the circuit to a transducer is opened
	Pump Efficiency	8	based on pump volume calculations (P512)
	Time of Day	9	based on the clock
	Clock Failure	10	if the clock module fails
	Pump Failure	11	based on P510
	Power Failure	12	based on P519
Flow page 79	Totalizer	40	every 10 <sup>y</sup> units (P640-P645)
	Flow Sampler	41	every n x 10 <sup>y</sup> units (P641-P645) or time duration (P115)
Pump page 80	Fixed Duty Assist	50	at fixed “on” and “off” setpoints and allows multiple pumps to run
	Fixed Duty Backup	51	at fixed “on” and “off” setpoints and allows only one pump to run
	Alternate Duty Assist	52	at rotating “on” and “off” setpoints and allows multiple pumps to run
	Alternate Duty Backup	53	at rotating “on” and “off” setpoints and allows only one pump to run
	Service Ratio Duty Assist	54	on service ratio at “on” and “off” setpoints and allows multiple pumps to run
	Service Ratio Duty Backup	55	on service ratio at “on” and “off” setpoints and allows only one pump to run
	First In First Out (FIFO)	56	as Alternate Duty Assist, resets the relay from staggered “off” setpoints.
Control page 82	Time	60	based on “duration” and “interval” setpoints
	Overflow	61	based on overflow event.
	Aeration	62	based on “duration” and “interval” setpoints timed from when pump relays shut off
	Gate	63	used to drive a gate based on “on”, “interval”, and “duration” setpoints
	Flush Valve	64	used to control a pump flushing device based on Flush Systems (P170 to P173)
	Communication	65	based on input from external communications. See the EnviroRanger Communications Reference for further information.

<sup>4</sup> When reading and setting this parameter through Modbus or SmartLinx communications the parameter values are mapped to different numbers. See the EnviroRanger Communications Reference (PL-558) for Modbus information and the appropriate SmartLinx manual for SmartLinx information.

## P111 (IR) Alarms (values 0-12)

EnviroRanger alarm relays are normally closed but can be adjusted using P118 (IR) Relay Output Logic on page 86.

### Power Failure

When power is cut to the EnviroRanger its relays fail in the following states:

Rack or Panel Mount		Wall Mount	
Relay	Fail State	Relay	Fail State
1-4	Open	1-4	Open
5	Closed	5	Open or Closed <sup>5</sup>

When programming the Rack or Panel versions to use relay 5 as a general alarm indicator, set P118 (IR) Relay Output Logic to value “3 – negative logic” and wire the alarm for normally open operation. When an alarm event occurs (described below) or when power is cut to the EnviroRanger the circuit closes and the alarm sounds.

### LCD Status Indicators

- Alarm off  
Relay contact closed  
P118 as preset
- Alarm on  
Relay contact open  
P118 as preset

### Level (1)

#### High level alarm

set the “on” setpoint (P112) above “off” setpoint (P113) in units (P005) or percent of span (P007).

#### Low level alarm





set the “on” setpoint (P112) below the “off” setpoint (P113) in units (P005) or percent of span (P007).

Level alarms can show other icons on the LCD if they are given a designation. The designation identifies the different alarms on the LCD and through communications.

Designation	Purpose	LCD Icon	Setpoints
(blank)	no indicator	none	as desired
HH	“Hi Hi” Alarm	▲▲	P112 > P113
H	High Alarm	▲▲▲	P112 > P113
L	Low Alarm	▼	P112 < P113
LL	“Lo Lo” Alarm	▼▼	P112 < P113

<sup>5</sup> Relay 5 is a Form C type on the Wall mount so you can wire it either normally open or normally closed. Check the wiring before programming.

To select a Level Alarm Designation (L,LL,H,HH or blank)...

1. Press  to display the Auxiliary Function symbol,
2. Press  or  as required to scroll to the alarm designation,
3. Press  to enter the value.

## In Bounds (2)

Use the “on” setpoint (P112) to define the top of the bounded area. Use the “off” setpoint (P113) to define the bottom of the bounded area. Use P116 (IR) Dead Band on page 86 to define the actual “on” and “off” setpoints around each boundary.

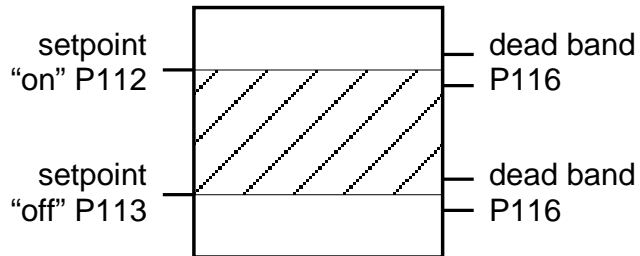

## Out of Bounds (3)

Use the “on” setpoint (P112) to define the top of the bounded area. Use the “off” setpoint (P113) to define the bottom of the bounded area. Use P116 (IR) Dead Band on page 86 to define the actual “on” and “off” setpoints around each boundary.

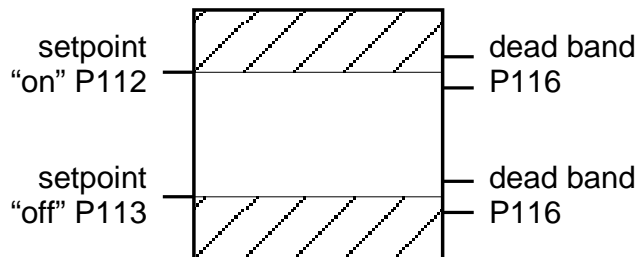

## Rate of Change (4)

Use the “on” setpoint to define the filling or emptying rate at which the alarm is tripped. This setpoint can be in:

- percent of span per minute
- units per minute

### Filling alarm

set the “on” and “off” setpoints as positive numbers

### Emptying alarm

set the “on” and “off” setpoints as negative numbers

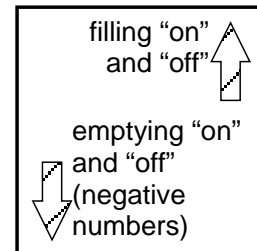

Any rate of change alarms must be set equal to or lower than the appropriate rate parameters or they will never trip. Check:

- P700 (G) Max Fill Rate on page 159
- P701 (G) Max Empty Rate on page 159

## Temperature (5)

Use the “on” and “off” setpoints to define the temperatures to trip and reset the alarm relay. All temperatures are specified in °C.

## Loss of Echo (6)

Use the loss of echo (LOE) alarm to trip a relay when the device fails to read echos. The timer for this fault is P070 (G) Failsafe Timer on page 69.

## Transducer Cable Fault (7)

Use the cable fault alarm to trip a relay when the device detects an open or short circuit on a transducer.

## Pump Efficiency (8)

Use the pump efficiency alarm to trip a relay when calculated pump efficiency falls. See Pump Efficiency (P180 to P186) on page 105 for details on how this alarm is set up.

## Time of Day (9)

Use the time of day alarm to trip a relay at the same time every day. Use the following two parameters to set when the alarm is tripped and for how long:

- P146 (IR) Time of Day Setpoint on page 98
- P114 (IR) Relay “duration” Setpoint on page 85

## Clock Failure (10)

Use the clock failure alarm to trip a relay if the clock module fails.

## Pump Failure (11)

Uses the status of P510 (IR) Pump Failed Status on page 134 to trip an alarm relay. The failure of any pump results in an alarm.

The alarm relay is reset when the status parameter is reset.

## Power Failure (12)

Uses the status of P519 (V) Power Failure Status to trip an alarm relay. When the power returns and P519 resets the alarm is reset.

# P111 (IR) Flow Totals (values 40-41)

EnviroRanger pump relays are normally open but can be adjusted using P118 (IR) Relay Output Logic on page 86.

## LCD Status Indicators

- Normal  
Relay contact open  
P118 as preset
- Totalizer pulse (momentary)  
Relay contact closed  
P118 as preset

The relay is activated by units of totalized flow from Pumped Volume or OCM:

## Pumped Volume (P001=7)

Calculates volume based on wet well draw down and pump run times. See Pumped Volume Totalizer (P622 to P623) on page 148 for details.

### Multiple Contacts

Pumped volume is calculated at the end of the pump cycle. Totalized volume given through a relay set up for “totalizer (40)” will be given in bursts at this time. Both the open and closed times for the relay contact are provided by P645 and are preset to 0.2 seconds. Partial units are added to the next pump cycle.

### Example

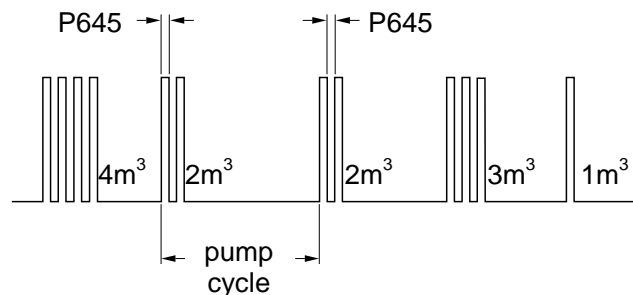

The example shows a relay set up to make 1 contact for every cubic metre (m³) of liquid.

## OCM (P001=6)

Calculates volume based on flow over the primary measuring device. See Open Channel Monitoring (OCM) on page 32 for details.

## Totalizer (40)

Use the totalizer to provide relay contact to an external counter using the following formula:

$$1 \text{ Contact per } 10^{P640} \text{ units}$$

P640 is preset to “0” so the default number of contacts for a pumped volume cycle is equivalent to P051 (G) Max Volume.

The source of units varies depending on the operation:

Operation	Units Source Parameter
OCM (P001=6)	P604 (G) Maximum Flow on page 143 P608 (G) Flowrate Units on page 145
Pumped Volume (P001=7)	P051 (G) Max Volume on page 63

#### Related

- P640 (G) Remote Totalized Multiplier on page 151
- P645 (G) Relay Duration on page 152
- P051 (G) Max Volume on page 63
- P645 (G) Relay Duration on page 152

### Flow Sampler (41)

A liquid flow sampler, as supported by the EnviroRanger, is a device which removes some liquid from a flow and stores it for later testing. To trigger a flow sampler based on volume use this value (P111=41). To trigger a flow sampler based on time use the Time control (P111=60).

The flow sampler triggers the relay by the following algorithm:

$$1 \text{ Contact per } P641 \times 10^{P642} \text{ units}$$

Operation	Units Source Parameter
OCM (P001=6)	P604 (G) Maximum Flow on page 143 P608 (G) Flowrate Units on page 145

By using a mantissa (P641) and an exponent (P642) the relay contacts can be based on a volume other than a multiple of ten.

#### Related

- P641 (G) Flow Sampler Mantissa on page 151
- P642 (G) Flow Sampler Exponent on page 152
- P645 (G) Relay Duration on page 152

### P111 (IR) Pumps (values 50-56)

For a comprehensive description of the available pump control strategies see Appendix C – Pump Control on page 215.

EnviroRanger pump relays are normally open but can be adjusted using P118 (IR) Relay Output Logic on page 86.

#### Pump Down (wet well)

set the “on” setpoint (P112) above the “off” setpoint (P113) in units (P005) or percent of span (P007).



### Pump Up (reservoir)

set the “on” setpoint (P112) below the “off” setpoint (P113) in units (P005) or percent of span (P007).

## LCD Status Indicators

- Pump off  
Relay contact open  
P118 as preset
- Pump on  
Relay contact closed  
P118 as preset

## Values

Duty	Assist	Backup
Fixed	50	51
Alternate	52	53
Service	54	55
FIFO	56	—

Discrete inputs can be used to remove pumps from the duty schedule. See Pump Interlock Allocation (P500 to P509) on page 128 for details.

### Assist (50, 52, 54, 56)

When more than one pump is started they run simultaneously.

### Backup (51, 53, 55)

When more than one pump is started the previously running pump is switched off. Only one pump at a time is ever running.

### Fixed (50, 51)

The “on” and “off” setpoints remain static (as programmed) for each pump relay.

### Alternate (52, 53)

The “on” and “off” setpoints are shared for the pump group and are rotated each time the material level cycles.

### Service (54, 55)

The “on” and “off” setpoints are shared for the pump group and pumps are started in order of run time based on a user-defined ratio. Ratios are specified using P122 (IR) Pump Service Ratio on page 89.

#### A Word on Pump Rotation

The EnviroRanger groups pumps together based on the Relay Function and the indexed transducer.

If there are four pumps indexed to a single transducer with two pumps assigned value 52 and two pumps assigned value 54 then the EnviroRanger groups both “52’s” and both “54’s” and performs the rotation on each group separately.

If all four pumps were assigned value “52” then all four would be grouped and rotation would happen on all four. The only way to circumvent this grouping is to use P137 (IR) Pump Group on page 52).

## FIFO (56)

The “on” and “off” setpoints are shared for the pump group and pumps are started using the alternate algorithm but are shut off using the “first in, first out” rule.

“Off” setpoints are generally staggered.

**Note:**

Do not use “FIFO” pump sequencing with volume totalization because for totalization to work all of the pump “off” setpoints must be the same.

## P111 (IR) Control (values 60-65)

EnviroRanger control relays are normally open but can be adjusted using P118 (IR) Relay Output Logic on page 86.

### LCD Status Indicators

- |  |  |
|--|--|
| <p><input type="radio"/> Control off<br/>Relay contact open<br/>P118 as preset</p> | <p><input checked="" type="radio"/> Control on<br/>Relay contact closed<br/>P118 as preset</p> |
|--|--|

### Values

Function	Description	Setpoints
Time	relay operation on elapsed time	P114, P115, P645
Overflow	relay operation on overflow conditions	P160-P165
Aeration	timed relay operation if pumps off	P114, P115
Gate	timed relay operation triggered by level	P112, P114, P115
Flush Valve	timed relay operation on pump cycles	P170-P173
Communication	relay operation controlled remotely	

## Time (60)

Use the "Time Control" Relay Function to activate a device based upon elapsed time.

e.g. Timed rake control to keep ram lubricated if idle for long periods or prevent ice build up in winter.

## Overflow (61)

Use the "Overflow Control" Relay Function to activate a device based upon high levels associated with Overflow conditions.

e.g. Open gate (valve) to divert overflow into a holding vessel and optionally turn off pumps. See Overflow / Underflow (P160 to P169) on page 99 for details.

## Aeration (62)

Use the "Aeration Control" Relay Function to activate a device based upon elapsed time since all pumps have been "OFF".

e.g. Timed fresh air introduction to reduce gas concentration or aerate sewage in a wet well.

## Gate (63)

Use the "Gate Control" Relay Function (EnviroRanger relays 1 and 2 only) to activate a drive motor for a specific time if level is outside a specified band.

Both relays must be used to control the gate (penstock), one for opening and one for closing.

See Gate Control on page 44 for more information.

e.g. Maintain constant level by time-step adjusting upstream gate based on downstream head.

## Flush Valve (64)

Use the "Flush Valve" Relay Function to activate a device for a specific time based upon pump cycle frequency.

e.g. Re-circulate into wet well periodically to stir up bottom solids so that they will be pumped out.

## Communication (65)

Use the "Communication" Relay Function to control the relay from an external device. This device communicates with the EnviroRanger using the built in Modbus protocol or optional SmartLinx card.

e.g. Control EnviroRanger relays via a digital communications port from a remote PC running a SCADA package.

## P112 (IR) Relay “on” Setpoint

*The process point at which the relay changes from its “normal” state.*

For most applications this is the point at which the relay is tripped. For “in-bounds” and “out-of-bounds” alarms it is the high point in the specified range.

This parameter is set according to Span (P007) even when another reading, such as volume, is shown on the LCD.

### Values

-999 to 9999

Preset: ----

### Related

- P100 (G) Preset Applications on page 72
- P111 (IR) Relay Control Function on page 74
- P113 (IR) Relay “off” Setpoint on page 84

## P113 (IR) Relay “off” Setpoint

*The process point at which the relay returns to its “normal” state.*

For most applications this is the point at which the relay is reset. For “in-bounds” and “out-of-bounds” alarms it is the low point in the specified range.

This parameter is set according to Span (P007) even when another reading, such as volume, is shown on the LCD.

### Values

-999 to 9999

Preset: ----

### Related

- P100 (G) Preset Applications on page 72
- P111 (IR) Relay Control Function on page 74
- P112 (IR) Relay “on” Setpoint on page 84

## P114 (IR) Relay “duration” Setpoint

*The length of time in minutes the relay is to be energized.*

This value must be less than the “interval” setpoint or the relay will never reset.

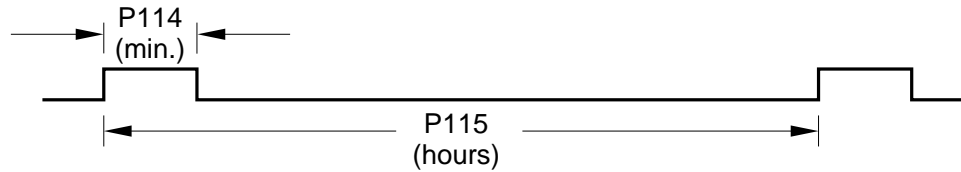

### Values

0.000 to 9999

Preset: ----

### Related

- P100 (G) Preset Applications on page 72
- P111 (IR) Relay Control Function on page 74 (P111=9,60,62,63)
- P115 (IR) Relay “interval” Setpoint on page 85
- P134 (IR) Pump Exercising on page 93 (P111=50 to 56)

## P115 (IR) Relay “interval” Setpoint

*The length of time in hours between timed starts.*

This value must be greater than the “duration” setpoint or the relay will never reset.

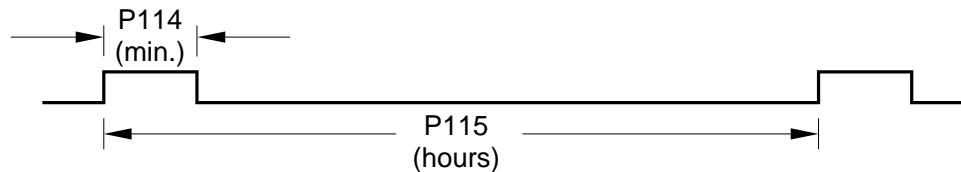

### Values

0.000 to 9999

Preset: ----

### Related

- P100 (G) Preset Applications on page 72
- P111 (IR) Relay Control Function on page 74 (P111=9,60,62,63)
- P114 (IR) Relay “duration” Setpoint on page 85
- P134 (IR) Pump Exercising on page 93 (P111=50 to 56)

## P116 (IR) Dead Band

*The distance above and below the bound alarm setpoints which actually energizes and de-energizes the alarm relays.*

For “in-bounds” and “out-of-bounds” Relay Functions (P111 = 2 and 3 respectively) a dead band prevents relay chatter due to material level fluctuations at both the upper and lower setpoints.

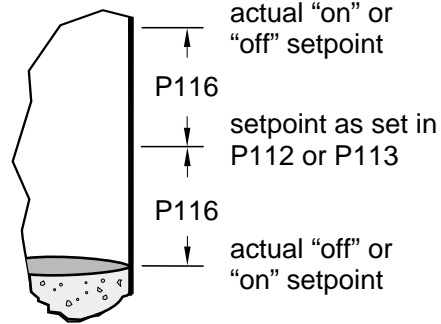

Enter the dead band in either percent of span or units of measure (P005). The dead band value is applied both above and below the upper and lower bound setpoints as shown in the figure.

### Values

0.000 to 9999  
Preset: 2% of span

### Related

- P100 (G) Preset Applications on page 72
- P111 (IR) Relay Control Function on page 74
- P112 (IR) Relay “on” Setpoint on page 84
- P113 (IR) Relay “off” Setpoint on page 84

## P118 (IR) Relay Output Logic

*The logic applied to relays to determine the contact open or closed state.*

The relay contact operation is “normally closed” for alarms and “normally open” for controls. See P111 (IR) Relay Control Function for more information.

### Power Failure

When power is cut to the EnviroRanger its relays fail in the following states:

Rack or Panel Mount		Wall Mount	
Relay	Fail State	Relay	Fail State
1-4	Open	1-4	Open
5	Closed	5	Open or Closed <sup>6</sup>

<sup>6</sup> Relay 5 is a Form C type on the Wall mount EnviroRanger so you can wire it either normally open or normally closed. Check the wiring before programming.

To use relay 5 as a general alarm indicator, set P118 to value “3 – negative logic” and wire the alarm for normally open operation. When an alarm event occurs (described below) or when power is cut to the EnviroRanger the circuit closes and the alarm sounds.

## Positive Logic

In software all relays are programmed the same way, with “on” setpoints indicating when to change the relay contact state (open or closed). This parameter allows the reversal of the operation so that relay contacts can be “normally closed” or “normally open.” P118 is preset to “2” which is positive logic.

## Negative Logic

When P118 = 3 (negative logic) the operation for the indexed relay is reversed from normal.

Values	Logic	Alarm Contact	Pump or Control Contact
2 *	positive logic	Normally Closed	Normally Open
3	negative logic	Normally Open	Normally Closed

### Related

- P111 (IR) Relay Control Function on page 74

## P119 (IR) Relay Logic Test

*Forces the relay control logic into an “activated” or “de-activated” state.*

Use this parameter to test your site wiring and control logic programming. Forcing the relay to an activated or de-activated state is similar to the EnviroRanger detecting an event and responding to it. This is helpful in testing new installations and diagnosing control problems.

### Values

0	*	off – control from EnviroRanger algorithms
1		activate relay control
2		de-activate relay control

### Related

- P111 (IR) Relay Control Function on page 74

# Pump Setpoint Modifiers (P121 and P122)

These parameters provide alternate ways of starting the pumps in the pump group. See Appendix C – Pump Control on page 215 for descriptions of the pump control algorithms.

## P121 (G) Pump by Rate

*Sets the pump relays to accept control by rate of level change once the first “on” setpoint is reached.*

Use this function when there are multiple pumps which should be controlled by rate of level change rather than setpoints. Pumping costs can be less because only the highest “on” setpoint needs to be programmed and this results in a lower difference in head to the next wet well which, in turn, results in less energy being used to pump out the well.

When the first “on” setpoint is reached the pumps will start, one by one, until the material level is changing at a rate the same or greater than the one specified in:

- P703 (G) Emptying Indicator on page 160 (pump down application)
- P702 (G) Filling Indicator on page 160 (pump up application)

The delay between pump starts is set by P132 (G) Pump Start Delay on page 92.

This parameter only applies to any relays set to pump control (P111 = 50 to 56).

### Notes:

- All pump control relay “on” and “off” setpoints must be set to the same value.
- If the level is within 5% of Span (P007) of the “off” setpoint then the next pump is not started.

### Values

- |   |   |                     |
|---|---|---------------------|
| 0 | * | off (pump by level) |
| 1 |   | on (pump by rate)   |

### Related

- P007 (IT) Span on page 60
- Rate (P700 to P708) on page 159
- P111 (IR) Pumps (values 50-56) on page 80



## P122 (IR) Pump Service Ratio

*Selects pump usage based on the run time ratio rather than last used.*

This parameter only relates to relays with P111=54 or 55.

To make this parameter useful, assign it to all of the pump relays. The number assigned to each pump relay represents the ratio that is applied when determining the next pump to start or stop.

### Example

Pump	Assigned Relay	Service Ratio
1	1	2
2	2	1

This service ratio would run pump one twice as often as pump two.

#### Notes:

- The EnviroRanger will not sacrifice other pumping strategies to ensure that the ratio is held true.
- If the pump relays are set to the same value then the ratio equals 1:1 and all pumps are used equally (preset).

Use this feature to predetermine pump usage if a "Pump Service Ratio" Relay Function (P111 = 54 or 55) is selected.

When more than one pump is assigned a Pump Service Ratio value (in any time units) and a pump start is required (Relay Setpoint "on", P112), the pump with the least running hours (with respect to the assigned ratio values) is started.

Conversely, when a pump stop is required (Relay Setpoint "off" (P113), the pump with the most running hours (as compared to the assigned ratio values), stops.

### Values

0.000 to 9999

Preset: 20.00

### Related

- P111 (IR) Relay Control Function on page 74
- Service on page 81

# Independent Relay Failsafe (P129)

## P129 (IR) Relay Failsafe

*Sets the failsafe operation per relay to allow for more flexible programming.*





Use this feature for relay failsafe operation independent from the Failsafe Material Level (P070).

Relay Failsafe is only available for the following relay functions (P111).

Relay Function (P111)	Preset (P129)
1 – level alarm	OFF
2 – in bounds alarm	
3 – out of bounds alarm	
4 – rate of change alarm	
5 – temperature alarm	
9 – time of day alarm	dE
50 to 56 – all pump controls	

Relay Failsafe is not used for any other relay control function.

To select an independent Relay Failsafe value:

1. Press  to display to the Auxiliary Function symbol,
2. Press  or  to scroll to the failsafe options.
3. Press  with the desired option displayed.

### Values

- OFF \* relay response governed by P071 (IT) Failsafe Material Level on page 70
- HOLd for "last known" relay state retention
- dE \* to have the relay de-energize immediately on failsafe
- En to have the relay energize immediately on failsafe

### Related

- P070 (G) Failsafe Timer on page 69
- P111 (IR) Relay Control Function on page 74

# Advanced Pump Control Modifiers (P130 to P136)

These parameters affect only relays set to pump operation (P111 = 50 to 56).

## P130 (G) Pump Run-On Interval

*Sets the number of hours between pump run-on occurrences.*

One technique of clearing sediment in a “pump-down” wet well is to occasionally run the pump, after the normal “off” setpoint is reached, to force some of the solid material through. This parameter indicates how many hours should elapse between pump run-on occurrences.

Only the last pump running is allowed to run-on.

### Values

0.000 to 1000  
Preset = 0.000

## P131 (G) Pump Run-On Duration

*Sets the number of seconds that the pump runs-on.*

Enter the duration of pump run-on in seconds. Care must be taken when choosing this value because the amount of material pumped out of the reservoir will vary with the pump capacity.

Choose a value long enough to clean out the vessel bottom, yet short enough not to run the pump dry (if that would damage the pump).

Because the duration is measured in seconds and the interval is measured in hours overlap is highly unlikely, however, ensure that the values used do not overlap. The timing should look something like this:

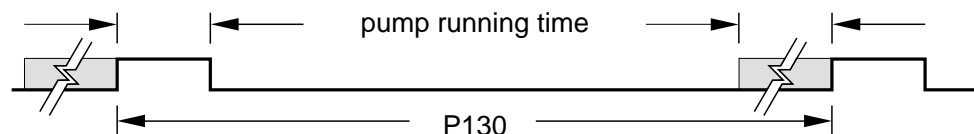

### Values

0.0 to 9999  
Preset = 0.000

## P132 (G) Pump Start Delay

*Stagger pump start times to reduce power surges.*

Use this feature to reduce the power surge that would occur if all pumps started simultaneously.

Enter the time to elapse (in seconds) after a pump has started before the next pump is permitted to start (if called for).

### Note

This value is divided by 10 when in simulation mode.

### Values

0.0 to 9999

Preset: 10 seconds

### Related

- P121 (G) Pump by Rate on page 88

## P133 (G) Pump Power Resumption Delay

*Delays the first pump restart after a power failure to reduce power surges.*

Use this feature to reduce the power surge that would occur if the first pump started immediately on power resumption.

Enter the time, in seconds, to elapse after power resumption (following a power interruption) before the first pump is permitted to start. Once this delay expires then the other pumps will start subject to the value specified for P132 (G) Pump Start Delay (above).

### Values

0.000 to 9999

Preset: 10 seconds

### Related

- P132 (G) Pump Start Delay on page 92

## P134 (IR) Pump Exercising

*Reduces pump corrosion or sediment build up by running the pump if it is idle for a long time.*

If a pump remains idle for the time (in hours) specified by P115 (IR) Relay “interval” Setpoint value entered then the pump runs for the time specified by P114 (IR) Relay “duration” Setpoint.

### Values

0	*	off
1		on (use P114 and P115 for timing information)

## P136 (G) Wall Cling Reduction

*Varies the upper and lower setpoints (Relay Setpoint “on” and “off”) to reduce material buildup on the reservoir walls at those points.*

This value is the range in which the setpoints are allowed to deviate in percent or units.

The Relay Setpoints “on” and “off” values are randomly varied inside the range to ensure that the material level does not consistently stop at the same point.

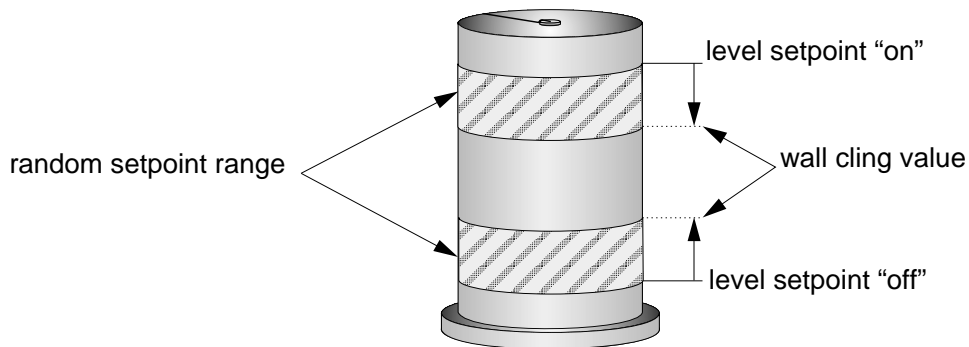

### Values

0.000 to 9999  
Preset: 0.000

## P137 (IR) Pump Group

*Assigns pumps to groups to allow for multiple pump rotations on one transducer.*

Use this feature to group pumps (relay points 1 - 5) into group 1 or 2.

The feature is applied to pump rotation and occurs independently within each group. Only the following values of P111 are affected by this parameter:

P111	Name
52	Alternate duty assist
53	Alternate duty backup

### Values

1	*	group 1
2		group 2

# Pump Energy Cost Reduction (P140 to P145)

These parameters affect only relays set to pump operation (P111 = 50 to 56).

Using these parameters you can configure an EnviroRanger to maximize its operation during periods of low energy cost and minimize its operation during periods of high-energy cost. The methods used to achieve this are:

1. Emptying the wet well just prior to the high cost period, regardless of material level (P141, P142, and P143)
2. Changing setpoints for high cost and low cost periods (P144 and P145)

## P140 (G) Energy Saving

*Maximizes pump use during periods of low energy costs and minimizes use during periods of high-energy cost.*

### Values

- |   |   |   |
|---|---|---|
| 0 | * | off   |
| 1 |   | on (do not pump during peak energy cost, if possible) |

## P141 (IB) Peak Start Times

*The time of day when high-energy costs (to be avoided) start.*

This value, in conjunction with Peak End Time, defines the high energy cost period. This value is indexed by the number of high energy cost periods required in a 24-hour span. Up to 10 periods may be programmed though one is usually sufficient.

All times are entered in 24-hour format.

### Values

HH.MM  
Preset: 00:00

## P142 (IB) Peak End Time

*The time of day when high energy costs (to be avoided) end.*

This value, in conjunction with Peak Start Time, defines the high energy cost period. This value is indexed by the number of high energy cost periods required in a 24-hour span. Up to 10 periods may be programmed though one is usually sufficient.

All times are entered in 24-hour format.

All end times must have the same index value as the corresponding start time.

### Values

HH.MM

Preset: 00:00

## P143 (G) Peak Lead Time

*The time (in minutes) before the Peak Start Time that the EnviroRanger will begin pumping.*

Enter the estimated pump running time (in minutes) required to pump the level from the highest Relay Setpoint “on” (P112) to the lowest Relay Setpoint “off” (P113) levels.

This value defines the time before the high energy cost period, when the EnviroRanger should start pumping to ensure the level is as far as possible from the Relay Setpoint “on” (P112) level.

(If the level is already within 5% of Span from the Relay Setpoint “off” (P113) level, no action is taken).

If multiple pump stations are series linked, ensure the Peak Lead Times entered are sufficient to attain the desired level in all stations before the high-energy cost period occurs.

### Values

0.000 to 1440

## P144 (IR) Peak “on” Setpoint

Enter the value (similar to Relay Setpoint “on”, P112) to be used for the high-energy cost period.

This feature allows the level to go beyond the normal Relay Setpoint “on” before a pump is started.

### Values

0.000 to 9999

Preset: 0.000



## P145 (IR) Peak “off” Setpoint

Enter the value (similar to Relay Setpoint “off”, P113) to be used for the high-energy cost period.

This feature allows the pump(s) to be stopped before the normal Relay Setpoint “off”, to reduce pump-running time during the high energy cost period.

### Values

0.000 to 9999

Preset: 0.000

## Energy Savings Example

The following example illustrates high energy cost usage reduction and/or elimination by utilizing the EnviroRanger Pump Energy Cost Reduction features on a wet well (pump down application).

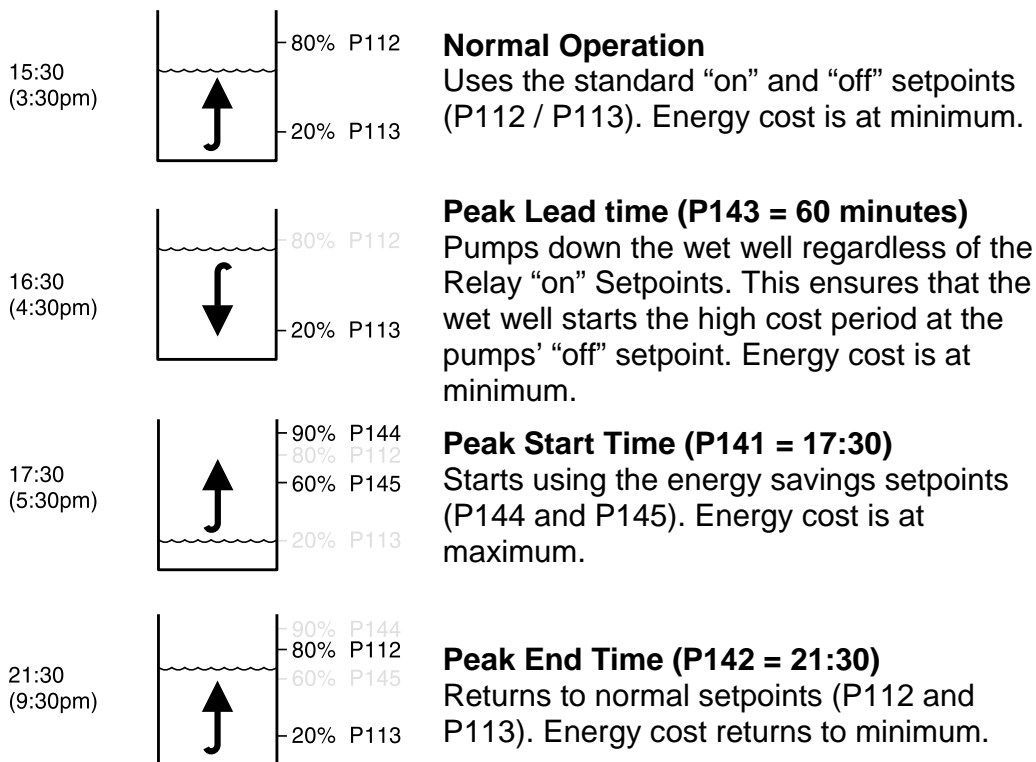

### Note:

When the Peak “on” Setpoint is not reached, no energy is used during the “high cost” period. If the Peak “on” Setpoint is reached, the Wet Well is only pumped down to 60%, thereby minimizing “high cost” energy usage.

## P146 (IR) Time of Day Setpoint

Use this feature to set the time at which a relay set for time day alarm (P111=9) will trip. Enter the time in HH.MM (24 hour) format.

### Values

00:00 to 23:59

# Overflow / Underflow (P160 to P169)

The overflow / underflow parameters allow the EnviroRanger to react to flow conditions caused by storms or other unusual events.

When the EnviroRanger enters a flow event the following actions are taken:

- **Logging starts.**  
See Overflow (CSO) Records (P313 to P316) on page 119 for details.
- **Relays are overridden.**  
See P165 (IR) Overflow / Underflow Relay Action on page 102 for details.
- **Control relays are tripped.**  
See P111 (IR) Control (values 60-65) on page 82 for details of option “61.”
- **Communications are updated.**  
See the EnviroRanger Communications Reference for details.
- **P169 is updated.**  
See P169 (V) Flow Condition on page 102 for details.

When the EnviroRanger ends a flow event the logging is stopped and all other actions are ended.

## P160 (G) Overflow / Underflow Level Source

*Defines the source used to detect a flow condition.*

The input for the flow condition is specified as x:y where:

	Input Type	x value	y value
<b>Overflow:</b>	Transducer	1	1 – transducer 1 2 – transducer 2 3 – average or difference (P001=4 or 5)
	Discrete Input	2	1 to 8 – references the DI used
<b>Underflow:</b>	Transducer	3	1 – transducer 1 2 – transducer 2 3 – average or difference (P001=4 or 5)
	Discrete Input	4	1 to 8 – references the DI used

For example, to configure a float to trigger an overflow event you would connect it to one of the discrete inputs, in this example 5, and the value for P160 would be 2:5.

**Note:**

You must specify the correct overflow or underflow settings for your “on” and “off” setpoints. If these values don’t match (for example, Overflow set as 1:1 and “on” setpoint below “off” setpoint) then no action is taken.

Use 0:0 to disable overflow logging. If either value is set to “0” then no overflow or underflow action is enabled.

To enter a colon “:”, press the decimal “.” button on the keypad.

**Values**

x:y

Preset: 0:0

**P161 (G) Overflow / Underflow Setpoint “on”**

*The point at which the flow event is triggered.*

This setpoint is used only if the level source (P160) is a transducer or mA input. If a discrete input is used to detect overflow or underflow then this parameter is ignored.

**Notes:**

- For overflow events the “on” setpoint must be above the “off” setpoint or no events are logged.
- For underflow events the “off” setpoint must be above the “on” setpoint or no events are logged.

**Values**

0.000 to 9999

Preset: 0.000

**P162 (G) Overflow / Underflow Setpoint “off”**

*The point at which the flow event is reset.*

This setpoint is used only if the level source (P160) is a transducer or mA input. If a discrete input is used to detect overflow or underflow then this parameter is ignored.

**Notes:**

- For overflow events the “on” setpoint must be above the “off” setpoint or no events are logged.
- For underflow events the “off” setpoint must be above the “on” setpoint or no events are logged.

## Values

0.000 to 9999

Preset: 0.000

## P163 (G) Overflow / Underflow Time Delay

*Defines the time, in seconds, used to calm (debounce) the flow condition inputs.*

The time delay is used only when the level source (P160) is a discrete input. Otherwise, the “off” setpoint is used.

The Overflow / Underflow Time Delay is a debounce timer used to keep the EnviroRanger from logging momentary flow conditions. The timer is used when the level source is no longer “on”. The flow condition remains in effect for the number of seconds specified in case the level source detects a flow condition again.

A value of 0 disables the timer.

## Values

0.000 to 9999

Preset: 5.0

## P164 (G) Overflow / Underflow Maximum Duration

*Defines the maximum time, in minutes, that a flow condition can remain in effect.*

A flow condition is reset by one of three events:

- The measured level moves past the “off” setpoint (P162)
- The discrete input (if used) is reset and the time delay (P163) expires
- The time of the flow condition exceeds the Flow Max Duration (P164) value

When the flow condition is reset, any forced relays revert back to their normally-programmed state. Ensure that the time given here is appropriate for the application.

Use 0 to disable this feature.

## Values

0.000 to 9999

Preset: 360.0

## P165 (IR) Overflow / Underflow Relay Action

*Determines how relays operate during a flow condition.*

When a flow condition is detected each relay can be forced on, forced off, or left in its normal state. Use this feature when you want a control device to activate on an overflow or underflow condition. This is useful for tracking CSO or for using floats to bypass the normal pump control.

Only relays that have been configured with a Relay Control Function (P111) of “alarm” or “pump” can be used. Relays with other programming cannot be overridden.

### Values

0	*	no action
1		forced on during overflow event
2		forced off during overflow event

### Related

- P111 (IR) Relay Control Function on page 74

## P169 (V) Flow Condition

*Indicates if the unit is in an overflow or underflow condition.*

### Values

0	*	normal operation
1		in overflow condition
2		in underflow condition

# Flush Systems (P170 to P173)

Use this feature to control an electrically operated flush valve on a pump. When a flush valve is run it usually diverts some pump output back into the wet well to stir up sediment.

**Note:**

The settings of these parameters affect the operation of all relays with P111 set to “64 – Flush Valve.”

For these parameters to work, all of them must be set to a value, if any of them are set to 0 then there is no effect.

## P170 (G) Flush Pump

*The number of the pump relay which triggers the flushing device.*

Enter the EnviroRanger relay number of the pump with the flush valve. The activation of this pump relay drives the usage of the flush system. Both P172 (G) Flush Interval and P171 (G) Flush Cycles are based on the operation of this relay and controls any relay set to P111 = 64, Flush Valve (see page 83).

**Values**

0 to 5  
Preset: 0

**Related**

- P111 = 64, Flush Valve on page 82

## P171 (G) Flush Cycles

*The number of pump cycles for which flush control is required.*

For example, if three flush cycles are required after every 10 pump cycles then:

- Flush Interval = 10
- Flush Cycles = 3

**Values**

0 to 9999  
Preset: 0

## P172 (G) Flush Interval

*The number of pump cycles which occur before flush control is enabled.*

To start a new flush cycle every ten times the pumps are run use the value "10" in this parameter.

### Values

0 to 9999

Preset: 0

## P173 (G) Flush Duration

*The length of time for each flush cycle that the flush control is active.*

This parameter holds the number of seconds that the flush control device is activated (through the flush control relay(s), P111=64).

### Values

0.000 to 9999

Preset: 0.000



## Pump Efficiency (P180 to P186)

The efficiency of the pumps is calculated on volume change in the wet well or reservoir. Any application using pump efficiency must have accurate values in the Volume (P050 to P055) parameters starting at page 62.

Pump faults can also be indicated by input from pump interlocks. See Pump Interlock Allocation (P500 to P509) on page 128 for more information.

### P180 (IR) Pump Capacity Reference

*The setpoint of Pump Capacity (P183) which triggers a pump low efficiency alert.*

The reference value is compared to the calculated value when the pump is started. If the level does not change as quickly as it should then a pump low efficiency alert is triggered.

This value is entered in percent of P183 (IR) Pump Rated Capacity.

#### Values

0.000 to 100.0

Preset = ----

#### Related

- Pump Efficiency (8) on page 78
- Appendix C – Pump Control on page 215
- Volume (P050 to P055) on page 62

### P181 (G) Pump Capacity Time

*The time, in seconds, that the actual pump capacity (P182) is calculated.*

If another pump is about to start or stop, or this pump is about to stop, the time is cut short and the calculation is done prematurely. The user can ensure that another pump does not start before the pump rate has achieved its operating value by increasing the pump start delay (P132).

#### Values

0.000 to 9999

Preset = 180 (sec)

## P182 (V)(IR) Pump Measured Capacity

*Displays the value of the actual Pump Capacity as calculated over the Pump Capacity time (P181).*

This parameter can be used to estimate the Pump Rated Capacity (P183) by running a pump cycle, then viewing this parameter. The units used depend on whether the volume parameters are configured.

### **If Volume has been set**

The result is given in volume (P051) units or percent per minute of pumped material.

### **If Volume has not been set**

The result is given in units (P005) or percent of span (P007) per minute of pumped material.

### **Values**

0 to 9999

## P183 (IR) Pump Rated Capacity

*The capacity for which the pump is rated.*

This is the value against which P180 is referenced given in units per minute. The units used depend on whether the volume parameters are configured.

### **If Volume has been set**

Enter the value in volume (P051) units per minute.

### **If Volume has not been set**

Enter the value in level units (P005) per minute.

### **Values**

0 to 9999

Preset: 100

## P184 (IR) Pump Low Efficiency Counter Setpoint

*The number of consecutive low efficiency events (defined by P180) before a low efficiency action (P185) is taken.*

This counter is reset every time the pump reaches the minimum efficiency as defined by P180.

### **Values**

0 to 9999

Preset: 3

## P185 (IR) Pump Low Efficiency Action

*The action taken when a pump's low efficiency counter (P184) expires.*

When the action removes a pump from the duty schedule P512 Pump Low Efficiency Fault is set. See the description on page 135 for details.

### Values

0	* No action
1	Alarm (any relays set for P111=8), set P512=1
2	Alarm, remove indexed pump from the duty schedule, set P510=1, P512=1

## P186 (V)(IR) Pump Low Efficiency Counter

*The current count of low efficiency events.*

This counter is iterated when the Pump Capacity Reference (P180) value isn't achieved by the indexed pump.

When this value reaches the Pump Low Efficiency Counter Setpoint (P184) then a Pump Low Efficiency Action (P185) is taken.

The value is reset to 0 when:

- The Pump Capacity Reference percent is achieved
- P510 is reset

### Values

0 to 9999

## mA Input (P250 to P254)

The mA input can be used as a level measurement or passed on to a SCADA system.

To use the mA input as a level set the transducer to "Auxiliary" (P004 = 250).

To pass the mA input on to a SCADA system, read the value from the appropriate communication registers. See the EnviroRanger Communications Reference for details.

### P250 (G) mA Input Range

*The mA output range of the connected mA device.*

Ensure this range is set to correspond to the output range of the external device. All level measurements will equate % of Span with the % of the mA range reading.

#### Values

1		0 to 20 mA
2	*	4 to 20 mA

#### Related

- P007 (IT) Span on page 60
- P006 (IT) Empty on page 59
- P004 (G) Transducer on page 58

### P251 (G) 0/4 mA Input Level

*The process level that corresponds to the 0 or 4 mA value.*

When using an external mA signal to determine level the input range must be scaled to give accurate results.

The preset value is 0% of Span (or equivalent units).

#### Values

-999 to 9999  
Preset: 0% of Span

#### Related

- P006 (IT) Empty on page 59
- P007 (IT) Span on page 60

## P252 (G) 20 mA Input Level

*The process level that corresponds to the 20 mA value.*

When using an external mA signal to determine level the input range must be scaled to give accurate results.

The preset value is 100% of Span (or equivalent units).

### Values

-999 to 9999

Preset: 100% of Span

### Related

- P006 (IT) Empty on page 59
- P007 (IT) Span on page 60

## P253 (G) Input Filter Time Constant

*The time constant used in the mA input filter to dampen unnecessary signal fluctuations.*

This value is the number of seconds used in the damping calculations. Larger values damp more, smaller values damp less. Using the value 0 disables the signal filter.

### Values

0 to 9999

Preset: 0

## P254 (V) Scaled mA Input Value

*The resulting level value after scaling.*

This parameter is view-only and cannot be changed as it is calculated from the input mA signal.

### Values

0 to 9999

## mA Input Trim (P260 to P262)

The EnviroRanger's mA inputs are calibrated at the factory. Use these parameters only if you know that your EnviroRanger requires recalibration.

**Note:**

Ignore any values given in P261 or P262.

### P260 (V) mA Raw Input

*Shows the raw mA input supplied by the external device.*

**Values**

0.000 to 20.00

### P261 (G) 4 mA Trim

*Calibrates the mA input to the bottom (4 mA) level.*

To calibrate the unit:

1. Connect a trusted 4 mA source to the mA inputs on the terminal block
2. Press 
3. L.CAL is shown on the LCD

The unit is now calibrated for 4 mA.

**Values:**

0.000 to 9999

### P262 (G) 20 mA Trim

*Calibrates the mA input to the top (20 mA) level.*

To calibrate the unit:

1. Connect a trusted 20 mA source to the mA inputs on the terminal block
2. Press 
3. H.CAL is shown on the LCD

The unit is now calibrated for 20 mA.

**Values:**

0.000 to 9999

# Discrete Input Functions (P270 to P275)

Discrete inputs can be used for the following:

- P160 (G) Overflow / Underflow Level Source as described on page 99
- Pump Interlock Allocation (P500 to P509) as described on page 128
- Passing other information to a remote system through communications

Use the following parameters to configure the discrete input itself. Use the referenced parameters above to use the discrete inputs to modify the EnviroRanger's operation.

See also Appendix C – Pump Control on page 215 for a detailed description of the EnviroRanger's pump control algorithms, including how the discrete inputs alter its operation.

## P270 (IDI) Discrete Input Function

*The way in which discrete signals are interpreted by the EnviroRanger.*

Use values 0 and 1 to test an installation. They simulate the discrete input in an on or off state.

Use 2 and 3 for normal operation based on how the inputs are wired.

Neither the 4 or 5 values (pulse counter and frequency input) affect the pump control algorithms. They can be used to communicate status to a SCADA system. These functions are only available for the advanced inputs (index 7 and 8).

### Values

0	Forced Off
1	Forced On
2	* Normally Open – 0 (DI open), 1 (DI closed)
3	Normally Closed – 0 (DI closed), 1 (DI open)
4	Pulse Counter
5	Frequency Input

### Related

- Pump Interlock Allocation (P500 to P509) on page 128
- Appendix C – Pump Control on page 215
- P275 (V)(IDI) Scaled Discrete Input Value on page 114

## P271 (IDI) Frequency Input 0Hz Offset

The value associated with 0Hz frequency input.

When the discrete input receives a signal of less than 1Hz this parameter determines what the scaled value is.

This parameter is valid only for discrete inputs set to the “Frequency Input (5)” function.

### Values

-999 to 9999

Preset: 0 (frequency input)

---- (for other inputs)

## Scaling Frequency Inputs

### Minimum Frequency = 0

To set discrete input 8 to report a scaled frequency range from 12 to 24 with a maximum input frequency of 10KHz use the following settings.

Parameter	Index	Value
P271	8	12
P272	8	24
P273	8	10

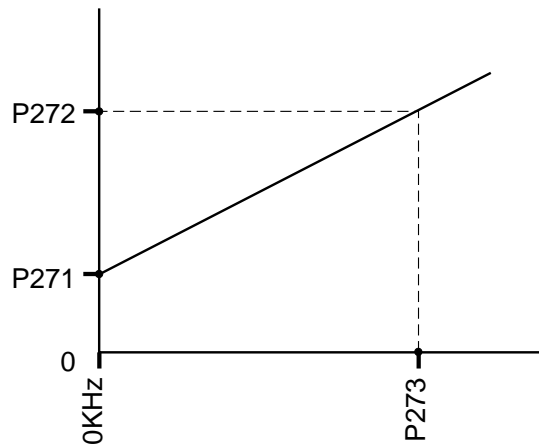

### Minimum Frequency > 0

To set discrete input 8 to report a scaled frequency range from 0 to +12 with a minimum frequency input of 5KHz and a maximum input frequency of 10KHz use the following settings.

Parameter	Index	Value
P271	8	-12
P272	8	24
P273	8	10

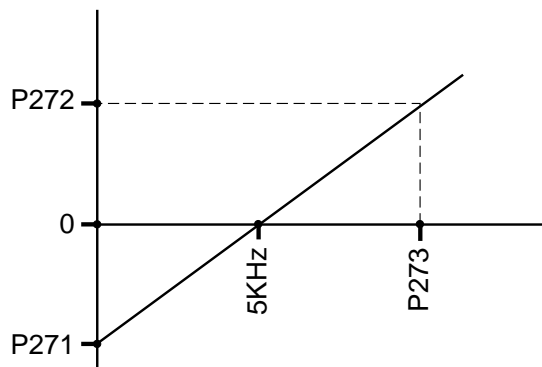



## P272 (IDI) Discrete Input Multiplier

*The upper value for Frequency Input or the increment value for a Pulse Counter.*

This parameter works with both the “Pulse Counter (4)” and the “Frequency Input (5)” functions.

### **Pulse Counter (P270 = 4)**

Sets the value to iterate for every pulse received. This allows the input value to be scaled as it is totalized. For example, a value of 10 here adds 10 to the count for every pulse received.

If you change this value the pulse counter resets to 0.

### **Frequency Input (P270 = 5)**

Sets the displayed value when the input is at the upper frequency range. Use with P273 (IDI) Frequency Input Upper Frequency.

### **Values**

0.0 to 9999  
Preset: 1.0 (pulse counter input)  
100.0 (frequency input)  
---- (for other inputs)

## P273 (IDI) Frequency Input Upper Frequency

*The maximum frequency allowed on a discrete input.*

This value is set in kHz and determines the point at which the scaled value shows the value of P272. Frequency inputs greater than the value specified are scaled above P272.

### **Value**

0.000 to 20.00  
Preset: 20.0 (frequency input)  
---- (other)

## P274 (IDI) Frequency Input Filter Time Constant

*The time constant used in the discrete input filter to dampen unnecessary signal fluctuations.*

This value is the number of seconds used in the damping calculations. Larger values damp more, smaller values damp less. Using the value 0 disables the signal filter.

This parameter is valid only for discrete inputs set to the “Frequency Input (5)” function.

**Values**

0.000 to 9999  
 Preset: 0 (frequency input)  
 ---- (other)

**P275 (V)(IDI) Scaled Discrete Input Value**

*The current value of the discrete input after any scaling is applied.*

These readings are updated continuously, even in program mode.

The value indicated here is used by pump interlocks or overflow detection to signal an event. 0 is a logical false and 1 is a logical true.

Frequency inputs can also be viewed as percent of P273 by pressing the percent button ( $\text{A}\%$ ) on the hand programmer.

Press  $\text{C}$  and then  $\text{↩}$  to reset the pulse counter (P270 = 4 only).

**Values**





The possible values of this parameter depend on the function of the discrete input:

Function	Range of Values
Forced On	1
Forced Off	0
Normally Open	0 (DI open), 1 (DI closed)
Normally Closed	0 (DI closed), 1 (DI open)
Pulse Counter	0 to 9999 (higher through communications)
Frequency Input	0 to 9999 (higher through communications)

**Related**

- Pump Interlock Allocation (P500 to P509) on page 128
- Pump Fault Status (P510 to P515) on page 134
- Pump Control Source (P520 to P524) on page 138

## Data Logging (P300 to P321)

- To view Data Logging time stamps press  and then .
- To view date stamps press  and then .

If the unit is powered up without a temperature sensor connected the value – 50C is displayed. This information can help trace problems with both built in and external temperature sensors.

All records can be reset by pressing  and then .



## Record Temperatures (P300 to P303)

*Use these features to view the occurrence of record high and / or low temperatures as recorded in °C.*

When a parameter relating to a TS-3 Temperature Sensor is accessed, the Point Type display changes to the TS-3 symbol.

### P300 (V)(IT) Temperature, Transducer Max

*View the highest temperature encountered, as measured by the temperature sensor in the transducer (if applicable).*



Press  and then  to reset the log after experiencing a short circuit on the transducer wiring.

#### Values

- 50 to 150°C  
Preset: -50°C

### P301 (V)(IT) Temperature, Transducer Min

*View the lowest temperature encountered, as measured by the temperature sensor in the transducer (if applicable).*

Press  and then  to reset the log after experiencing an open circuit on the transducer wiring.

#### Values

- 50 to 150°C  
Preset: 150°C

## P302 (V) Temperature, Sensor Max

*View the highest temperature encountered, as measured by the TS-3 Temperature Sensor (if applicable).*

Press  and then  to reset the log after experiencing a short circuit on the temperature sensor wiring.

### Values

- 50 to 150°C  
Preset: - 50°C

## P303 (V) Temperature, Sensor Min

*View the lowest temperature encountered, as measured by the TS-3 Temperature Sensor (if applicable).*

Press  and then  to reset the log after experiencing an open circuit on the temperature sensor wiring.

### Values

- 50 to 150°C  
Preset: 150°C

## Record Readings (P304 and P305)

Use these features to identify the occurrence of the record high and low level readings.

Press  and then  to reset these values once the installation is working correctly.

### P304 (V)(IT) Reading Max

*View the highest Reading calculated (in normal Reading units or %).*

#### Values

-999 to 9999

### P305 (V)(IT) Reading Min

*View the lowest Reading calculated (in normal Reading units or %).*

#### Values

-999 to 9999

## Pump Records (P310 to P312)

Use these features to identify pump usage.

These features are enabled if the associated Relay Function (P111) is set for any "pump control" feature. The value displayed pertains to the pump connected to the associated EnviroRanger terminals.

Enter a value to set the current record to that value. This can be used if a pump is added with a known number of hours logged or the value can be reset to zero "0" after maintenance.

### P310 (IR) Pump Hours

*View or reset the accumulated "ON" time for the displayed Relay Number.*

This value is displayed with a floating decimal point. (i.e. the more figures displayed before the decimal, the fewer displayed after).

This is the value displayed when is pressed in the RUN mode as described on page 12.

#### Values

0.000 to 9999

### P311 (IR) Pump Starts

*View or reset the accumulated number of times the displayed Relay Number has been "on".*

This is the value displayed when is pressed and held for five seconds in the RUN mode as described on page 12.

#### Values

0 to 9999

### P312 (IR) Pump Run Ons

*View or reset the accumulated number of times the displayed Relay Number has been held "on" via Run On Interval (P130).*

#### Values

0 to 9999





# Overflow (CSO) Records (P313 to P316)

These records cannot be reset.

The index contains 20 entries with 1 being the most recent and 20 being the least recent. When more than 20 records are stored new ones will “wrap” and write over the oldest ones.

Flow events are logged immediately, so if the system is in overflow state when the overflow records are viewed then the first record shows the current event.

## To view Overflow Records

1. Enter Program mode
2. Press  and then  again to highlight the index field  
The field shows two underscores \_\_
3. Type the index number (for example, 02)  
The indexed record is shown and the data often overwrites the index number
4. Use  and  to scroll through the records

## P313 (V) Overflow Event Dates

View the dates of the 20 most recent overflow events in the format (YY:MM:DD).

The year overwrites the index number.

Blank entries show as 70:01:01.



rack or panel display shown

## P314 (V) Overflow Event Times

View the times, in 24-hour format (HH:MM:SS) of the 20 most recent overflow events.

The seconds overwrite the index number.

Blank entries show as 00:00:00.

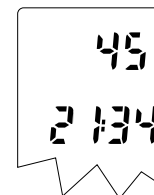

rack or panel display shown

## P315 (V) Overflow Event Duration

View the duration, in minutes of the 20 most recent overflow events.

Blank entries show as 0.00.

# Flow Records (P320 and P321)

These features are enabled if Operation is set for "OCM" (P001 = 6). Use these features to identify the occurrence of the record high and low flow rates as displayed in OCM Max Flow (P604) units, or as a percent of OCM Max Flow.

Press  and then  to reset these values once the installation is working correctly.

## P320 (V) Flow Max

*View the highest flow rate calculated (in units or %).*

### Values

-999 to 9999

## P321 (V) Flow Min

*View the lowest flow rate calculated (in units or %).*

### Values

-999 to 9999



# LCD Totalizer (P322 and P323)

Use these features to view, reset, or preset the 8 digit display totalizer.

These features may be enabled if Operation is set for "OCM" or "Pumped Volume" (P001 = 6 or 7).

The 8 digit totalizer is divided into 2 groups of 4 digits. The 4 least significant totalizer digits are stored in P322 and the 4 most significant digits are stored in P323. Adjust these values separately to set a new total.

## Example

P323	P322	Totalizer Display
0017	6.294	00176.294

Totalizer units are dependent upon programming.

Enter "0" (if desired) when these parameters are accessed, to reset the totalizer to zero. Alternatively, enter any other (applicable) value, to preset the totalizer to the value desired.

## P322 (G) LCD Total Low

*View and / or alter the 4 least significant digits of the totalizer value.*

### Values

0.000 to 9999

### Related

- P630 (G) LCD Totalized Multiplier on page 150
- P633 (G) LCD Totalized Decimal Position on page 150
- P737 (G) Primary Reading on page 168

## P323 (G) LCD Total High

*View and / or alter the 4 most significant digits of the totalizer value.*

### Values

0000 to 9999

### Related

- P630 (G) LCD Totalized Multiplier on page 150
- P633 (G) LCD Totalized Decimal Position on page 150
- P737 (G) Primary Reading on page 168

# Profile Records (P330 to P337)

## WARNING:

The following parameters are for authorized Milltronics service personnel or Instrumentation Technicians familiar with Milltronics echo processing techniques.

Use these features to record and save a total of up to 10 Echo profiles, initiated manually (P330), or automatically (P331 et al). See Scope displays (P810) for echo profile viewing hardware / software requirements.

If 10 Echo Profiles are already saved, addresses 1 through 10 are filled, the oldest automatically initiated record is overwritten. Manually initiated records are not automatically overwritten. All records are automatically deleted in the event of a power interruption.

When a record is displayed, results are based on current programming (which may have been altered since the record was saved). This permits the effect on the echo profile to be observed when changing an echo parameter.





## P330 (IE) Profile Record.

*Records profiles for later viewing.*

In addition to serving as a library for profile records, this parameter provides two functions:

- manually records and saves echo profiles
- displays an echo profile, recorded manually or automatically, e.g. via an oscilloscope.

### To select a record address

1. Enter Program mode
2. Press  and then  again to highlight the index field  
The field shows two underscores \_ \_
3. Type the index number (for example, 02)  
The profile record information is shown (codes described below)
4. Use  and  to scroll through the records

### Profile Record Information

Code	Description
----	no record
A1	automatically recorded profile from transducer 1
A2	automatically recorded profile from transducer 2
U1	manually recorded profile from transducer 1
U2	manually recorded profile from transducer 2

**To manually record a profile**

Press  to fire the transducer and record the echo profile into the internal scope buffer for display.



For differential or average operation (P001 = 4 or 5), access scope Displays (P810) parameter to select the transducer number.

**To save a manual record**



Press  to copy the echo profile record in the scope buffer and save it in the selected address in the record library. The parameter value field displays the new record information.

**To display a record**

Press  to enter display auxiliary mode and then:

- Press  to display the time the profile was taken
- Press  to display the date the profile was taken
- Press  to copy the current echo profile into the scope buffer for display on an oscilloscope or Dolphin Plus

**To delete a record**

Press  and then  to delete the echo profile record in the selected address. The value returns to - - - -.

**P331 (G) Auto Record Enable**

*Use this feature to enable / disable the Auto Profile Record function.*

**Values**

0	*	Off
1		On

**P332 (G) Auto Record Transducer**

*Use this feature to specify the Transducer Point Number for which Auto Profile Records are saved.*

This feature is preset to Point Number 1. (Alteration is only required if "differential" or "average" Operation (P001 = 4 or 5) is selected).

**Values**

0		Any transducer
1	*	Transducer 1
2		Transducer 2

## P333 (G) Auto Record Interval

*Enter the time (in minutes) to elapse after an Auto Profile Record is saved before another Auto Profile Record can be saved (subject to all other restrictions).*

### Values

0.0 to 9999

Preset: 120

# Auto Record “on” and “off” Setpoints (P334 to P337)

Use Auto Record “on” Setpoint (P334) and Auto Record “off” Setpoint (P335) to define the boundaries within which the level must be, for the resultant Echo Profile to be considered for an Auto Profile Record.

If "----" is displayed for either P334 or P335, Auto Profile Records are saved regardless of current level (subject to all other restrictions).

Enter the level value in Units (P005) or percent of Span (P007) as referenced to Empty (P006).

## P334 (G) Auto Record “on” Setpoint

*Enter the critical level which, in conjunction with Auto Record “off” Setpoint, defines the boundaries for Auto Profile Records to be saved.*

### Values

-999 to 9999

## P335 (G) Auto Record “off” Setpoint

*Enter the critical level which, in conjunction with Auto Record “on” Setpoint, defines the boundaries for Auto Profile Records to be saved.*

### Values

-999 to 9999

## P336 (G) Auto Record Filling / Emptying

*Use this feature to restrict Auto Profile Records from being saved unless the level is rising, falling or either.*

If the level changes at a rate in excess of the corresponding Filling / Emptying Indicator (P702 / P703) values, the Echo Profile is saved subject to this and other Auto Profile Record restrictions.

### Values

- 0 \* Auto Profile Record on filling or emptying
- 1 Auto Profile Record on filling only
- 2 Auto Profile Record on emptying only

## P337 (G) Auto Record LOE Time

*Use this feature to restrict Auto Profile Records from being saved unless an extended loss of echo (LOE) condition occurs.*

If the LOE condition exceeds the period entered (in seconds) the Echo Profile is saved, subject to this and other restrictions.

When set for "0" (preset), LOE is not required for an Auto Profile Record to be saved.

### Values

0.0 to 9999

Preset: 0.0

## Installation Records (P340 to P342)

Use these features to view data relating to this specific EnviroRanger installation.

### P340 (V) Date of Manufacture

*View the date of manufacture of this EnviroRanger.*

#### Values

YY:MM:DD format

### P341 (V) Run Time

*View the accumulated number of days this EnviroRanger has been operating, since the Date of Manufacture (P340).*

This value is updated once each day. Therefore, if the EnviroRanger is powered down at least once every 24 hour period, this value will always be less than 1.

#### Values

0.000 to 9999

### P342 (V) Start Ups

*View the accumulated number of times power has been applied to the EnviroRanger (following a power interruption), since the Date Of Manufacture.*

#### Values

1 to 9999

## Pump Interlock Allocation (P500 to P509)

Discrete inputs allow you to feed pump information to the EnviroRanger so that it can modify pump algorithms. See Appendix C – Pump Control on page 215 or Appendix D – Discrete inputs on page 223 for more information.

All of these parameters are indexed by pump relay. All relays are available for indexing but only those set to pump control in the Relay Control Function (P111 = 50 to 56) will be affected by these parameters. For most pump applications only a simple discrete input is required. Inputs 7 and 8 can be used but must be configured as P270 = 3 or 4.

When a pump is determined to be in failed state the appropriate Pump Fault Status (P510 to P515) parameter (page 134) is set to “1” and any programmed actions take place.

### See Also

- Connecting a Pump Control Interlock on page 31
- Discrete Input Functions (P270 to P275) on page 111
- Pump Fault Status (P510 to P515) on page 134
- Pump Control Source (P520 to P524) on page 138
- Appendix C – Pump Control on page 215
- Appendix D – Discrete inputs on page 223

## P500 (IR) Pump Auto Allocation

*Determines whether the indexed pump relay is controlled by the EnviroRanger or by a manual override switch.*

A value of zero “0” indicates that the pump relay does not use a physical manual override switch. A value of 1 to 8 indicates the discrete input to watch for auto or manual status.

With P270 as preset (NO circuit), the value generated by the discrete input (P275) is interpreted:

P275 Value	P500 Meaning
0	Pump in manual
1	Pump in auto

### Note:

P500 is reversed from most other interlock parameters, “1” is the normal state and “0” is the exception state.



### For Example

If a three-position “Run/Off/Auto” switch is connected to discrete input 3 with the following contacts:

Switch Position	Discrete Input #3 Circuit
Run	Open
Off	Open
Auto	Closed

Then, for an EnviroRanger with three pumps, the following parameters would be set

Parameter	Index	Value	Description
P500	1	3	Sets all three pumps to respect the switch position.
P500	2	3	
P500	3	3	
P270	3	2	Auto operation = closed circuit

### Values

0 to 8  
Preset: 0

### Related

- P275 (V)(IDI) Scaled Discrete Input Value on page 114
- P111 (IR) Pumps (values 50-56) on page 80
- P520 (V)(IR) Pump Available on page 138
- P521 (V)(IR) Pump in Local Auto on page 138

## P501 (IR) Pump Remote Control Allocation

*Determines whether remote access to pump control is enabled.*

A value of “0” indicates that no discrete inputs are used. In this case P515 (V)(IR) Pump Remote Control Status defaults to “0” and can be set through communications.

A value of 1 to 8 indicates the discrete input to watch for remote control status.

When remote control is disabled then remote hosts cannot affect pump control directly. See the EnviroRanger Communications Reference for more information on controlling the device from a remote system.

The value is reported in P515 and comes from P275 indexed to the specified input.

P275 Value	P501 Meaning
0	Pump in local only
1	Pump available for remote control

**Note:**  
 This parameter allows for remote control of the pump but does not automatically set it up. Remote control must be initiated from the remote system through the Pump Control and Status register. See the EnviroRanger Communications Reference (PL-558) for details.

**Values**

0 to 8  
 Preset: 0

**Related**

- P275 (V)(IDI) Scaled Discrete Input Value on page 114
- P515 (V)(IR) Pump Remote Control Status on page 136

**P502 (G) Power Failure Allocation**

*Determines if the site is experiencing a power failure.*

Use this parameter when the EnviroRanger is supplied with backup power and the pumps are not. If a power failure is detected on the specified discrete input then:

- A power failure event is initiated and any relays set for power failure alarm (P111 = 12) are triggered
- All new pump alarms are ignored (existing alarms remain in effect)
- Pumps are stopped

When the power resumes and the discrete input returns to its normal state:

- The power failure event ends and alarms reset
- The pumps start based on their setpoints (P112 and P113) and the delay parameters (P132 and P133)

P275 Value	P502 Meaning
0	Power normal
1	Power failure detected

**Values**

0 to 8  
 Preset: 0

**Related**

- P275 (V)(IDI) Scaled Discrete Input Value on page 114
- P519 (V) Power Failure Status on page 137
- P111 (IR) Alarms (values 0-12) on page 76

## P503 (IR) Pump Run Status Allocation

*Determines whether the indexed pump is running.*

When EnviroRanger activates a pump relay it assumes that the pump is running. To verify this assumption a circuit can be set up to confirm the run status from the motor starter to a discrete input.

A value of zero “0” indicates that the pump does not use a “running” interlock. A value of 1 to 8 indicates the discrete input to watch for running status.

The value is reported in P511 and comes from P275 indexed to the specified input.

P275 Value	P503 Meaning
0	Pump not running
1	Pump running

If the pump is activated by the EnviroRanger and the Run Status input is not set then the EnviroRanger assumes that the pump has failed and will remove that pump from the duty cycle.

### Values

0 to 8  
Preset: 0

### Related

- P275 (V)(IDI) Scaled Discrete Input Value on page 114
- P504 (IR) Pump Run Status Time Delay on page 131
- P511 (V)(IR) Pump Run Fault Status on page 135

## P504 (IR) Pump Run Status Time Delay

*Specifies the time, in seconds, between when the EnviroRanger commands a pump to run and when it checks the status of the discrete input.*

To use this time delay a relay must have P503 (IR) Pump Run Status Allocation set to a discrete input.

### Values

0000 to 9999  
Preset: 5 (sec)

### Related

P503 (IR) Pump Run Status Allocation on page 131

## P505 (IR) Pump Fault “A” Allocation

*Detects whether there is a fault on the indexed pump.*

When a pump is capable of reporting faults in operation it can be connected to a discrete input and this information can be used by EnviroRanger to modify its pump control algorithms.

A value of zero “0” indicates that the pump does not use fault interlocks. A value of 1 to 8 indicates the discrete input to watch for operation status.

The value is reported in P513 and comes from P275 indexed to the specified input.

P275 Value	P505 Meaning
0	Pump ok
1	Pump in fault condition

When the pump enters a fault condition it is removed from the duty cycle.

### Values

0 to 8  
Preset: 0

### Related

- P275 (V)(IDI) Scaled Discrete Input Value on page 114
- P111 (IR) Pumps (values 50-56) on page 80
- P513 (V)(IR) Pump Fault “A” Status on page 136

## P506 (IR) Pump Fault “B” Allocation

*Detects whether there is a fault on the indexed pump.*

When a pump is capable of reporting faults in operation it can be connected to a discrete input and this information can be used by EnviroRanger to modify its pump control algorithms.

A value of zero “0” indicates that the pump does not use fault interlocks. A value of 1 to 8 indicates the discrete input to watch for operation status.

The value is reported in P514 and comes from P275 indexed to the specified input.

P275 Value	P506 Meaning
0	Pump ok
1	Pump in fault condition

When the pump enters a fault condition it is removed from the duty cycle.

**Values**

0 to 8  
Preset: 0

**Related**

- P275 (V)(IDI) Scaled Discrete Input Value on page 114
- P514 (V)(IR) Pump Fault “B” Status on page 136

## P509 (IR) Pump Reset Allocation

*Resets the pump fault status parameters using a momentary contact.*

When a contact is made on the referenced discrete input all pump faults are reset for the indexed pump and that pump is put back into the duty schedule.

A value of zero “0” indicates that no discrete inputs are watched for reset. In this case any pump faults must be reset using the hand programmer and P510 or through communications. A value of 1 to 8 indicates the discrete input to watch for pump reset.

To allow the contact to reset all pumps use index 0.

The discrete input only works in run or simulation modes and is triggered by the change in state of P275 from 0 to 1.

**Values**

0 to 8  
Preset: 0

**Related**

- P275 (V)(IDI) Scaled Discrete Input Value on page 114
- P510 (IR) Pump Failed Status on page 134

## Pump Fault Status (P510 to P515)

Use these parameters to determine which condition failed the indexed pump. All relays are available for indexing but only those set to pump control in the Relay Control Function (P111 = 50 to 56) will be affected by these parameters. Once the cause of the failure condition is fixed, use a push button connected to a discrete input (P509) or the parameter P510 to reset a failure condition.

Once back in run mode, if the indexed pump relay symbol stops flashing on the LCD then that pump has returned to normal status. If it keeps flashing then there is still a failure reported and the pump relay will not be used.

All of these parameters are latched and will not reset automatically. Use P510 to reset all status parameters for an indexed pump relay.

To reset the fault status, do one of the following:

- Change the parameter value to 0 using Dolphin Plus or a hand programmer
- Change the pump low volume alarm bit to 0 using communications. See the EnviroRanger Communications Reference for complete details.

### P510 (IR) Pump Failed Status

*Reports whether the indexed pump has failed and allows for reset.*

When any of the other status parameters (listed below) is set to 1 (failed) then this parameter is also set to 1. The parameter is indexed by relay.

Before resetting this parameter to 0, check the other 510-series parameters to determine which one caused the fault. This parameter will show a “1” rather than a “0”.

When a pump fails the value for the indexed relay changes from 0 to 1. It remains in failed state (1) until reset through communications, the hand programmer, or a push button connected to a discrete interlock (P509).

Reset this latched parameter by changing the indexed value to 0.

Resetting this parameter resets all of these other parameters to 0:

- P510 (IR) Pump Failed Status
- P511 (V)(IR) Pump Run Fault Status
- P512 (V)(IR) Pump Low Efficiency Fault (from P185)
- P513 (V)(IR) Pump Fault “A” Status
- P514 (V)(IR) Pump Fault “B” Status
- P186 (V)(IR) Pump Low Efficiency Counter

**Values**

0	*	normal operation
1		pump failed

**Related**

- P503 (IR) Pump Run Status Allocation on page 131
- P505 (IR) Pump Fault “A” Allocation on page 131
- P506 (IR) Pump Fault “B” on page 132
- P509 (IR) Pump Reset on page 133
- P185 (IR) Pump Low Efficiency Action on page 107
- P186 (V)(IR) Pump Low Efficiency Counter on page 107

**P511 (V)(IR) Pump Run Fault Status**

*Reports status of P503 (IR) Pump Run Status Allocation after P504 (IR) Pump Run Status Time Delay has expired.*

**Values**

0	*	normal operation
1		fault detected

**Related**

- P503 (IR) Pump Run Status Allocation on page 131
- P504 (IR) Pump Run Status Time Delay on page 131

**P512 (V)(IR) Pump Low Efficiency Fault Status**

*Reports pump efficiency status based on efficiency calculations.*

See Pump Efficiency (P180 to P186) on page 105 for details.

The value of P185 (IR) Pump Low Efficiency Action determines how these parameters are updated:

P185 value	Updated Parameters
0 – no action	no action
1 – Alarm	P512 = 1
2 – Alarm and fail pump	P510 = 1, P512 = 1

**Values**

0	*	normal operation
1		fault detected

**Related**

- Pump Efficiency (P180 to P186) on page 105

## P513 (V)(IR) Pump Fault “A” Status

*Reports status of P505 (IR) Pump Fault “A” Allocation.*

### Values

0	*	normal operation
1		fault detected

### Related

- P275 (V)(IDI) Scaled Discrete Input Value on page 114
- P505 (IR) Pump Fault “A” Allocation on page 132

## P514 (V)(IR) Pump Fault “B” Status

*Reports status of P506 (IR) Pump Fault “B” Allocation.*

### Values

0	*	normal operation
1		fault detected

### Related

- P275 (V)(IDI) Scaled Discrete Input Value on page 114
- P506 (IR) Pump Fault “B” Allocation on page 132

## P515 (V)(IR) Pump Remote Control Status

*Reports status of P501 (IR) Pump Remote Control Allocation or remote control bit.*

If P501 (IR) Pump Remote Control Allocation is used then this parameter reports the result of the discrete input.

If P501 is not used then this parameter reports the value of the remote control bit which is set in communications. See the EnviroRanger Communications Reference for details.

### Values

0	*	pump in local mode, remote disabled
1		pump in remote mode, remote enabled

### Related

- P275 (V)(IDI) Scaled Discrete Input Value on page 114
- P501 (IR) Pump Remote Control Allocation on page 129



## P519 (V) Power Failure Status

*Reports the status of P502 (G) Power Failure Allocation.*

### Values

0	*	power available
1		power failure

### Related

- P275 (V)(IDI) Scaled Discrete Input Value on page 114
- P502 (G) Power Failure Allocation on page 130
- P111 (IR) Alarms (values 0-12) on page 76

# Pump Control Source (P520 to P524)

Use these parameters to determine from where the EnviroRanger pump relays are controlled:

	Auto	Manual
Local	P521	P522
Remote	P523	P524

## P520 (V)(IR) Pump Available

*Indicates whether the pump is available to the EnviroRanger pump control routines.*

When operating normally pumps will always be available. The pump can become not available if it is put into “manual” mode or if there is a detected pump fault through the discrete inputs.

### Values

0		pump not available
1	*	pump available

## P521 (V)(IR) Pump in Local Auto

*Indicates that control of the indexed pump is exclusively through the EnviroRanger pump control algorithms.*

See Appendix C – Pump Control on page 215 for a description of these algorithms.

### Values

0		pump not in local / auto
1	*	pump in local / auto

## P522 (V)(IR) Pump in Local Manual

*Indicates that control of the indexed pump is exclusively from a discrete input.*

Usually a three-way (on-off-auto) switch mounted near the EnviroRanger is used to put the unit into Local Manual mode and to control the pump.

### Values

0	*	pump not in local / auto
1		pump in local / manual

## P523 (V)(IR) Pump in Remote Auto

*Indicates that control of the indexed pump is from the EnviroRanger pump control algorithms and that remote control is enabled.*

See the EnviroRanger Communications Reference for details on the pump controls available through communications.

### Values

0	*	pump not in remote / auto
1		pump in remote / auto

## P524 (IR) Pump in Remote Manual

*Indicates that control of the indexed pump is exclusively through communications from a remote system.*

See the EnviroRanger Communications Reference for details on the pump controls available through communications.

### Values

0	*	pump not in remote / manual
1		pump in remote / manual

# OCM (P600 to P621)

If the EnviroRanger is used to monitor open channel flow, alter the following parameters as required and run a calibration as described in P621.

**Note:**

See Open Channel Monitoring (OCM) on page 32 for application examples involving common weirs and flumes.

The EnviroRanger calculates "head" as referenced to Empty (P006) or OCM Zero Offset (P605), when Operation is set for "OCM" (P001 = 6). Flowrate, based on head (at the "point of measure" specified by the PMD fabricator) is also calculated and displayed on the LCD.

Some PMDs require a larger Range Extension (P801) to avoid entering the LOE failure state if the water level falls below the bottom of the PMD. See P801 (G) Range Extension on page 176 for more information.

## P600 (G) Primary Measuring Device

*The type of primary measuring device (PMD) used.*

The EnviroRanger is pre-programmed for common PMD flow calculations. If the PMD used is not listed below, select the appropriate Universal Flow Calculation.

Associated parameters (as indicated below), Max Head (P603), Max Flow (P604), and Min Head (P605) may be scroll accessed.

If Operation is not set for "OCM" (P001 = 6), this value is preset to "0". If Operation is set for "OCM", this value is preset to "1".

### Values

0	*	off (no calculation)
1		Exponential (see P601)
2		Palmer-Bowlus Flume (see P602)
3		H-Flume (see P602)
4		Universal Linear Flow Calculation (see P610, P611)
5		Universal Curved Flow Calculation (see P610, P611)
6		BS-3680/ISO 4359 Rectangular Flume (see P602)
7		BS-3680/ISO 1438/1 Thin Plate V-Notch Weir (see P602)

### Related

- P601 (G) Flow Exponent on page 141
- P602 (ID) PMD Dimensions on page 142
- P610 (IB) Head Breakpoints on page 145
- P611 (IB) Breakpoint on page 146

# P601 (G) Flow Exponent

*The Exponent for the flow calculation formula.*

Use this parameter if the Primary Measuring Device (P600) is set to 1 (exponential). It creates an exponential curve with end points set by Max Head (P603) and Zero Head (P604) and with the curve based on the specified exponent.

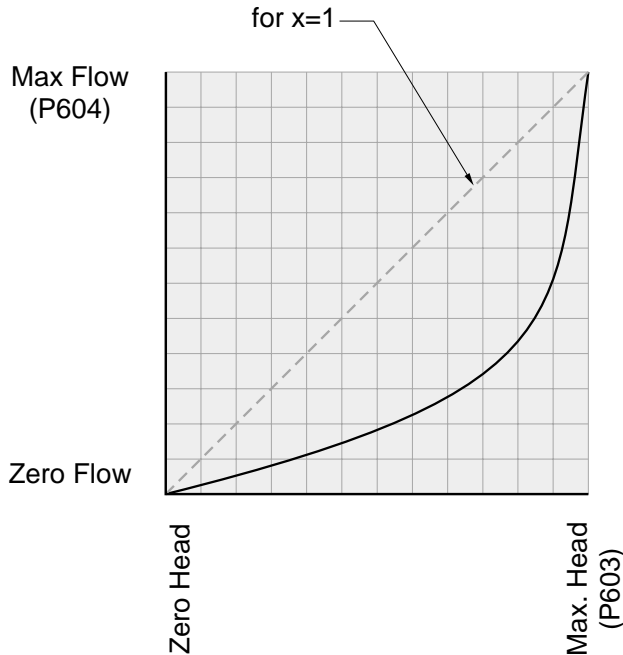

## A Word on Exponents

The exponential equation is:

$$Q = KH^{P601}$$

Where:

Q = flow  
K = internal constant  
H = head

Parameter Reference

Use the exponent specified by the PMD manufacturer, if available, or the sample value given below.

## Example Exponents

PMD Type	Exponent (sample only)
Suppressed Rectangular Weir	1.50
Cipolletti Weir	1.50
Venturi Flume	1.50
Parshall Flume	1.22 to 1.607
Leopold Lagco	1.547
V-Notch Weir	2.50

## Values

-999 to 9999

Preset: 1.55

## Related

- P603 (G) Maximum Head on page 142
- P604 (G) Maximum Flow on page 143
- P605 (G) Zero Head on page 143

## P602 (ID) PMD Dimensions

*The dimensions of the Primary Measuring Device (PMD).*

Use this parameter if the Primary Measuring Device is directly supported (P600=2,3,6,7). The dimensions required for each PMD vary. See the examples on page 32 for full descriptions of the required values (listed below for reference).

### Index Values for Supported PMDs

Parameter Reference

Supported PMD Type (page reference of example)							
ISO 1438/1 (pg. 35)		ISO 4359 (pg. 36)		Palmer Bowlus (pg. 37)		H Flume (pg. 38)	
1	Notch Angle	1	Approach width	1	Flume width	1	Flume height
2	Discharge Coefficient	2	Throat width				
		3	Hump Height				
		4	Throat Length				
		5	Velocity coefficient				
		6	Discharge coefficient				

## P603 (G) Maximum Head

*The head value associated with Maximum Flow, in Units (P005).*

Use this parameter when the Primary Measuring Device (PMD) requires a maximum head and flow reference point. These PMDs are:

- P600 = 1, Exponential
- P600 = 2, Palmer Bowlus Flume
- P600 = 3, H Flume
- P600 = 4 and 5, Universal breakpoints

This value represents the highest head level supported by the PMD. It works in conjunction with Maximum Flow (P604) to define the highest point in the exponential curve.

### Values

-999 to 9999

Preset = Span (P007) value

### Related

- P604 (G) Maximum Flow on page 143
- P605 (G) Zero Head on page 143

## P604 (G) Maximum Flow

*The maximum flowrate associated with Maximum Head (P603).*

Use this parameter when the Primary Measuring Device (PMD) requires a maximum head and flow reference point. These PMDs are:

- P600 = 1, Exponential
- P600 = 2, Palmer Bowlus Flume
- P600 = 3, H Flume
- P600 = 4 and 5, Universal breakpoints

This value represents the flow at the highest head level supported by the PMD. It works in conjunction with Maximum Head (P603) to define the highest point in the exponential curve.

Use this parameter with Time Units (P606) to define the flowrate units.

The limitation of four digits is for the LCD only. The flowrate value is available with greater precision through communications.

e.g. If flowrate is to be displayed in millions of gallons / day, and the maximum flowrate is 376,500,000 gallons / day, enter “376.5” for Maximum Flow (P604) and “4” for Time Units (P606).

### Values

-999 to 9999  
Preset = 1000

### Related

- P603 (G) Maximum Head on page 142
- P606 (G) Time Units on page 144

## P605 (G) Zero Head

*The distance above Empty (P006) in Units (P005) representing zero head (and zero flow).*

This feature can be used for most weirs and some flumes (e.g. Palmer Bowlus) where the zero reference is at a higher elevation than the channel bottom.

### Note:

When a value is specified for P605 the Span (P007) is raised by the same amount. This can result in the top of the Span being too close to the transducer face. Ensure that Span is correct when using P605.

**Values**

-999 to 9999  
 Preset = 0.000

**Related**

- P006 (IT) Empty on page 59
- P801 (G) Range Extension on page 176

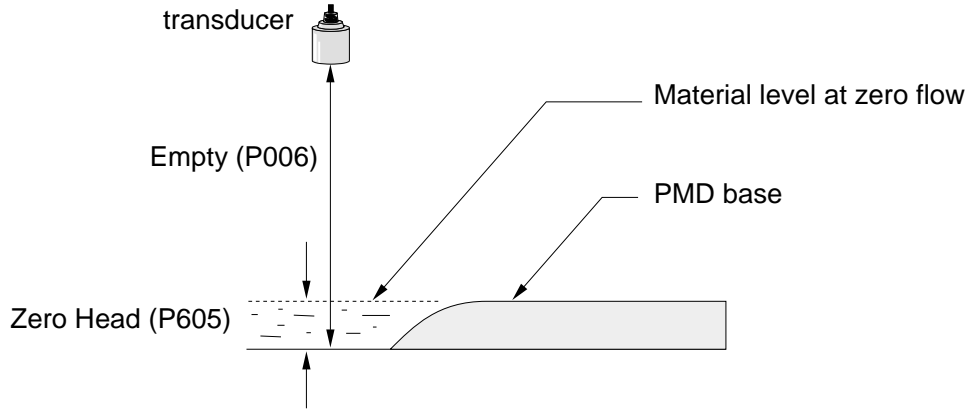

**P606 (G) Time Units**

*Determine the time units used when displaying current flow and logging flow values.*

This parameter is used when the Primary Measuring Device is “Ratiometric” (P608=0).

e.g. If flowrate is to be displayed in millions of gallons / day, and the maximum flowrate is 376,500,000 gallons / day, enter “376.5” for Maximum Flow (P604) and “4” for Time Units (P606).

**Values**

- 1        seconds
- 2        minutes
- 3        hours
- 4        \*    days

**P607 (G) Flowrate Decimal**

*The maximum number of decimal places to be displayed.*

In the Run mode, the number of decimal places displayed is automatically adjusted (if necessary) to prevent the number of Flowrate digits from exceeding display capabilities.

The max. number of "head" decimal places is controlled by Decimal Position (P060).



## Values

0	no digits after the decimal point
1	1 digit after the decimal point
2	2 digits after the decimal point
3	3 digits after the decimal point

## Related

- P060 (IT) Decimal Position on page 66

## P608 (G) Flowrate Units

*The volume units used to display total flow.*

This parameter is enabled only if the primary measuring device (PMD) supports absolute calculations (P600=6,7).

For absolute PMDs (P600=6,7) volume units can be specified using this parameter. If required absolute PMDs can still use the ratiometric (P608=0) setting to accommodate other units.

## Values

### Ratiometric (P600=all)

0	*	Ratiometric calculation (units defined by P604)
---	---	---

### Absolute (P600=6,7 only)

1	litres / second
2	cubic metres / hour
3	cubic metres / day
4	cubic feet / second
5	gallons / minute – Imperial
6	million gallons / day – Imperial
7	gallons / minute – U.S.
8	million gallons / day – U.S.

## P610 (IB) Head Breakpoints

*The head breakpoints for which flowrate is known.*

These are the values in the Span for which flowrates are known. See Universal Calculation Support on page 42 for a description of how to specify universal flows.

## Values

0.000 to 9999

## Head vs. Flowrate (P610 and P611)

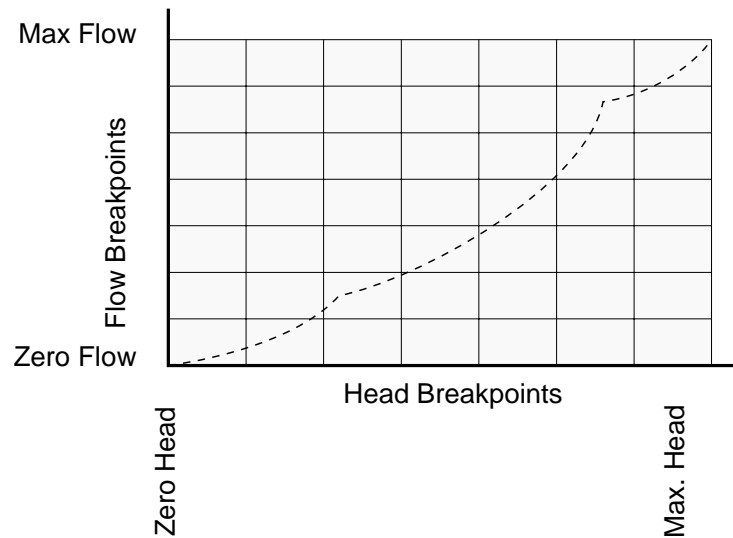

### P611 (IB) Breakpoint Flowrates

*The flowrate corresponding to each Head Breakpoint entered.*

These are the flowrates for the related breakpoints. See Universal Calculation Support on page 42 for a description of how to specify universal flows.

#### Values

0.000 to 9999

### P620 (G) Low Flow Cutoff

*Eliminates totalizer activity for flows at or below the cutoff value.*

Use this feature to enter the minimum head in units (P005) or as a percent of span.

#### Values

0.000 to 9999

Preset = 5.000 %, or equivalent units

#### Related

- P005 (G) Units on page 59
- P007 (IT) Span on page 60

## P621 (G) Auto Zero Head

*Calibrates Zero Head (P605) based on actual head measurements.*

Use this parameter when the reported head is consistently high or low by a fixed amount.

Before using this feature, verify the following parameters are correct:

- Empty (P006)
- Temperature (P664)
- Offset Reading (P062=0)
- Zero Head Offset (P605)

### Procedure

With "head" steady ...

1. Press  to display the calculated head
2. Repeat step 1 at least 5 times to verify repeatability
3. Measure the "actual" head (e.g. with a tape measure or solid rule)
4. Enter the "actual" head value

The deviation between the entered Empty (P006) value and the calibrated Empty value, is stored in Offset Correction (P652). Alternatively, the Empty parameter (P006) can be corrected directly.

### Values

-999 to 9999

# Pumped Volume Totalizer (P622 to P623)

If the 8 digit totalizer display, or a remote totalizer contact closure is desired, alter the following parameters as required.

## P622 (G) Inflow / Discharge Adjust

*The method used to calculate the volume pumped, for "pumped total" Operation (P001 = 7).*

### Values

#### 1 = inflow \* / pump cycle

When the pump is off, the EnviroRanger estimates the volume of inflow by recording the rate at which the liquid level changes. When the pump is operating, the estimated inflow volume is added to the pumped volume total. When the pump stops, the pumped volume of the previous pump cycle is added to the total volume pumped in the totalizer.

#### 2 = inflow \* ignored

Inflow is assumed to be 0 while pumps are running.

#### 3 = inflow \* / rate (preset)

Volume pumped is adjusted for inflow. Inflow rate is estimated by assuming that the rate calculated (P708) just prior to the start of the pump cycle remained constant during the pump cycle. Inflow rate is averaged using rate filter (P704), rate update time (P705) and rate update distance (P706) to control how the average rate is calculated.

\* or discharge

## P623 (G) Pump Total Method

This parameter determines the method used for updating the pumped volume totalizer.

### Values

#### 1 = Volume readings at Start and End

Volume pumped is calculated from the volume readings at the start and end of the pump cycle. The result is compensated for estimated inflow which is added to the total volume change while pumps are running. Inflow rate is estimated as selected by the inflow / discharge adjust (P622).

#### 2 = Pump Capacity and Running Time (preset)

Volume pumped is calculated from the Pump Capacity (P182) for each pump, and the running time of each pump. Pump Capacity is recalculated on each pump cycle, based on the rate of change of level or volume before and after each pump starts. Accuracy of the totalizer when using this selection is

entirely dependent on the accuracy of the rate calculation, so the user must ensure that appropriate settings are entered for Pump Capacity Time (P181) and Pump Start Delay (P132).

# Totalizer (P630 to P645)

## P630 (G) LCD Totalized Multiplier

Use this feature if the LCD Total increments by too large (or too small) an amount.

Enter the factor (powers of 10 only) by which actual volume is divided, prior to display on the LCD. Use a value such that the eight-digit totalizer doesn't roll over between readings.

e.g. for an LCD Total display in 1000's of volume units, enter 3.

### Values

-3		.001
-2		.01
-1		.1
0	*	1
1		10
2		100
3		1000
4		10,000
5		100,000
6		1,000,000
7		10,000,000

### Related

- LCD Totalizer (P322 and P323) on page 121

## P633 (G) LCD Totalized Decimal Position

Enter the maximum number of decimal places to be displayed.

In the RUN mode, the number of decimal places displayed is not automatically adjusted. When the LCD Total value is so large as to exceed display capabilities, the total "rolls over" to "0" and continues incrementing.

### Values

0	no digits after the decimal point
1	1 digit after the decimal point
2	2 digits after the decimal point
3	3 digits after the decimal point

### Related

- LCD Totalizer (P322 and P323) on page 121

## P640 (G) Remote Totalized Multiplier

Use this feature if the remote totalizer (device connected to the relay set for "totalizer operation" Relay Function, P111 = 40), updates too slowly or rapidly.

This parameter is relevant only if Operation is set to OCM or Pumped Volume (P001 = 6 or 7).

The relays on the EnviroRanger have a maximum frequency of 2.5 Hz.

Enter the factor (powers of 10 only) by which actual volume is divided, prior to Remote Totalizer count increment.

e.g. for a Remote Totalizer update by 1000's of volume units, enter 3.

### Values

-3		.001
-2		.01
-1		.1
0	*	1
1		10
2		100
3		1000
4		10,000
5		100,000
6		1,000,000
7		10,000,000

### Related

- P001 (G) Operation on page 57
- P111 (IR) Relay Control Function on page 74
- P114 (IR) Relay "duration" Setpoint on page 85
- P115 (IR) Relay "interval" Setpoint on page 85
- P645 (G) Relay Duration on page 152

## P641 (G) Flow Sampler Mantissa

Use this feature in conjunction with Flow Sampler Exponent (P642) to establish the number of flow units required to increment the Flow Sampler (device connected to the EnviroRanger relay set for the "flow sampler operation" Relay Function, P111 = 41).

This parameter is relevant only if Operation is set to OCM (P001 = 6).

Enter the mantissa (Y) for the exponent (Z) in the formula...

Flow Sampler Increment =  $Y \times 10^Z$  Flow units.

e.g. To count once every 4310 ( $4.31 \times 10^3$ ) flow units, set P641 to 4.31 and P642 to 3.

**Values**

0.001 to 9999  
 Preset = 1.000

**Related**

- P001 (G) Operation on page 57
- P111 (IR) Relay Control Function on page 74
- OCM (P600 to P621) on page 140

**P642 (G) Flow Sampler Exponent**

Use this feature in conjunction with Flow Sampler Mantissa (P641) to establish the number of flow units required to increment the Flow Sampler (device connected to the EnviroRanger relay set for the "flow sampler operation" Relay Function, P111 = 41).

This parameter is relevant only if Operation is set to OCM (P001 = 6).

Enter the exponent (Z) for the mantissa (Y) in the formula...

$$\text{Flow Sampler Increment} = Y \times 10^Z \text{ Flow units.}$$

**Values**

-3 to +7 (integers only)  
 Preset = 0

**Related**

- P001 (G) Operation on page 57
- P111 (IR) Relay Control Function on page 74
- OCM (P600 to P621) on page 140

**P645 (G) Relay Duration**

Use this feature (if desired) to adjust the minimum contact closure duration of a relay set as a totalizer or flow sampler (P111 = 40 or 41).

Enter the minimum contact closure duration (in seconds) required by the device connected.

For the flow sampler function this value is used for both the "on" time of the relay and the "off" time between contacts.

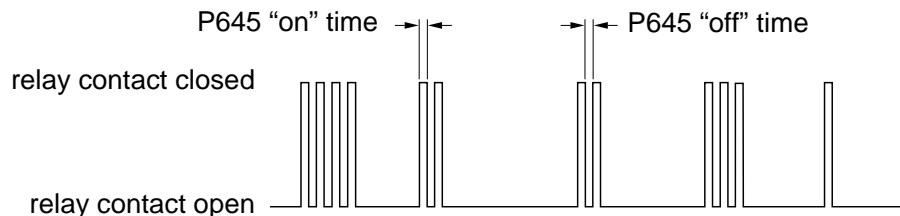



**Values**

0.1 to 1024

Preset = 0.2 (sec)

**Related**

- P111 (IR) Relay Control Function on page 74

## Range Calibration (P650 to P654)

There are two types of calibration possible:

### Offset

Adjusts the measurements by a fixed amount.

### Sound Velocity

Adjusts the speed of sound and changes the measurement calculations.

Do Offset calibration at any steady level unless a Sound Velocity calibration is also done. If both calibrations are done then do Offset at a known high level and Sound Velocity at a known low level.

## P650 (G) Offset Calibration

*Calibrates Empty (P006) if the reported level is consistently high or low by a fixed amount.*

Before using this feature, verify the following parameters are correct:

- Empty (P006)
- Temperature (P664)
- Offset Reading (P062)
- Zero Head Offset (P605)

With the level steady...

1. Press  to display the calculated reading
2. Repeat step 1 at least 5 times to verify repeatability
3. Measure the actual reading (e.g. with a tape measure)
4. Enter the actual value

The deviation between the entered Empty (P006) value and the calibrated "Empty" value, is stored in Offset Correction (P652).

### Values

-999 to 9999

## P651 (G) Sound Velocity Calibration

*Changes the speed of sound constant.*

Use this feature if:

- The acoustic beam atmosphere is other than "air"
- The acoustic beam atmosphere temperature is unknown
- The Reading accuracy is acceptable at higher material levels only

For best results do this calibration with the level at a known value near empty.

With the level steady at some low value...

1. Allow sufficient time for the vapour concentration to stabilize
2. Press  to display the calculated reading
3. Repeat step 2 at least 5 times to verify repeatability
4. Measure the actual reading (e.g. with a tape measure)
5. Enter the actual value

(Velocity parameters P653 and P654 are adjusted accordingly).

Repeat this procedure if the atmosphere type, concentration, or temperature varies from that present when the last sound velocity calibration was performed.

**Note:**

In gasses other than air the temperature variation may not correspond with the speed of sound variation. In these cases turn off the temperature sensor and use a fixed temperature.

**Values**

-999 to 9999

## P652 (G) Offset Correction

*The value altered when an Offset Calibration is performed.*

Alternatively, if the amount of Offset Correction required is known, enter the amount to be added to the Reading before display.

**Values**

-999 to 999.0

## P653 (G) Velocity

*The value adjusted based on the "Sound Velocity at 20 °C (P654) vs. Temperature (P664) characteristics of air".*

Alternatively, enter the current sound velocity (if known), or perform a Sound Velocity Calibration (P651).

The units used are m/s if P005 = 1, 2, or 3 (ft/s if P005 = 4 or 5).

**Values**

50.01 to 2001 m/s (164.1 to 6563 ft/s)

## P654 (G) Velocity at 20°C

*This value is used to automatically calculate Sound Velocity (P653).*

After performing a Sound Velocity Calibration, check this value to verify the acoustic beam atmosphere is "air" (344.1 m/s or 1129 ft/s).

Alternatively, if the acoustic beam atmosphere sound velocity at 20°C (68 °F) is known, and the sound velocity vs. temperature characteristics are similar to that of "air", enter the sound velocity.

The units used are m/s if P005 = 1, 2, or 3 (or ft/s if P005 = 4 or 5).

### Values

50.01 to 2001 m/s (164.1 to 6563 ft/s)

# Temperature Compensation (P660 to P664)

## P660 (IT) Temp Source

*Source of the temperature reading used to adjust the speed of sound.*

The EnviroRanger measures the TS-3 temperature sensor assigned to the transducer. If a TS-3 sensor is not connected, the temperature measurement from the ultrasonic/temperature transducer is used. If the transducer used does not have an internal temperature sensor, the Temp Fixed (P661) value is used.

If the acoustic beam atmosphere temperature varies with distance from the transducer, connect a TS-3 Temperature Sensor and ultrasonic / temperature transducers, and select "average".

In gasses other than air the temperature variation may not correspond with the speed of sound variation. In these cases turn off the temperature sensor and use a fixed temperature.

### Values

- |   |   |                                   |
|---|---|-----------------------------------|
| 1 | * | AUTO                              |
| 2 |   | Temp Fixed                        |
| 3 |   | Ultrasonic/Temperature Transducer |
| 4 |   | TS-3 Temperature Sensor           |
| 5 |   | Average (TS-3 and transducer)     |

## P661 (IT) Temp Fixed

*Use this feature if a temperature sensing device is not used.*

Enter the temperature (in °C) of the atmosphere within the transducer acoustic beam. If the temperature varies with distance from the transducer, enter the average temperature.

### Values

-199 to 199 (preset = 20 °C)

## P663 (IT) Temperature Transducer Allocation

*This feature may only be used for "differential" or "average" Operation (P001 = 4 or 5).*

As preset, the temperature measurements of Ultrasonic / Temperature Transducer # 1 and 2 are allocated to Point Number 1 and 2 respectively.

Use this feature (if desired) if the temperature measurement from both transducers should be identical, however one transducer is mounted in

direct sunlight (or near some other radiant heat source). Allocate the temperature measurement of the other transducer to both transducer Point Numbers.

Enter the Transducer Number whose temperature measurement will be used for the distance calculation of the Point Number displayed.

When both transducers are allocated to a Point Number, the temperature measurements from each transducer are averaged.

**Values**

1	*	Transducer # 1
2		Transducer # 2
1:2		Transducer # 1 and 2 average

**P664 (V)(IT) Temperature**

*View the transducer temperature in °C.*

This is the value displayed when  is pressed in RUN mode as described on page 12.

If Temp Source (P660) is set to any value other than Fixed Temp, the value displayed is the temperature measured. If Temp Source is set to Fixed Temp, the P661 value is displayed.

**Values**

-50 to 150

## Rate (P700 to P708)

The Rate parameters determine how the EnviroRanger reports changes in material level.

### P700 (G) Max Fill Rate

*Adjusts the EnviroRanger response to increases in the actual material level (or advance to a higher Failsafe Material Level, P071).*

Enter a value slightly greater than the maximum vessel filling rate.

This value, in Units (P005) or % of Span (P007) per minute, is automatically altered when Maximum Process Speed (P003) is altered.

P003 Value	Meters / Minute
1	0.1
2	1
3	10

Any fill rate above this value will trigger any alarms set to “rate”.

#### Values

0.000 to 9999

### P701 (G) Max Empty Rate

*Adjusts the EnviroRanger response to decreases in the actual material level (or advance to a lower Failsafe Material Level, P071).*

Enter a value slightly greater than the maximum vessel emptying rate.

This value, in Units (P005) or % of Span (P007) per minute, is automatically altered when Maximum Process Speed (P003) is altered.

P003 Value	Meters / Minute
1	0.1
2	1
3	10

Any empty rate above this value will trigger any alarms set to “rate”.

#### Values

0.000 to 9999

## P702 (G) Filling Indicator

*The fill rate required to activate the LCD Filling indicator (†).*

This value (in Units (P005) or % of Span (P007) per minute) is automatically set to 1/10 of the Max Fill Rate (P700).

### Values

-999 to 9999

## P703 (G) Emptying Indicator

*The empty rate required to activate the LCD Emptying indicator (†).*

This value (in Units (P005) or % of Span (P007) per minute) is automatically set to 1/10 of the Max Empty Rate (P701) .

### Values

-999 to 9999

## P704 (G) Rate Filter

*Damps Rate Value (P707) fluctuations.*

This value is automatically altered when Maximum Process Speed (P003) is altered. See Maximum Process Speed on page 203.

This value automatically alters the Rate Update Time (P705) and / or Rate Update Distance (P706). Alternatively, these parameter values may be altered independently.

Enter the time or distance interval over which the Rate Value is to be calculated before the display updates.

### Values

0 rate display not required

### Filtered Output

1 continuously filtered and updated

### Interval Output

2 1 minute or 50 mm (2 in)  
 3 5 minutes or 100 mm (3.9 in)  
 4 10 minutes or 300 mm (11.8 in)  
 5 10 minutes or 1000 mm (39.4 in)



### Related

- P003 (IT) Maximum Process Speed on page 58
- P705 (G) Rate Update Time on page 161
- P706 (G) Rate Update Distance on page 161

## P705 (G) Rate Update Time

*The time period (in seconds) over which the material level rate of change is averaged before Rate Value update.*

### Values

0.000 to 9999

## P706 (G) Rate Update Distance

*The material level change (in metres) to initiate a Rate Value update.*

### Values

0.000 to 9999

## P707 (V)(IT) Rate Value

*The rate of material level change (in Units (P005) or % of Span (P007) per minute).*

(A negative rate indicates the vessel is emptying).

This is the value displayed when  is pressed in the run mode as described on page 12.

### Values

-999 to 9999

## P708 (V)(IT) Volume Rate Display

*The rate of change of volume in “percent of maximum volume” per minute.*

This value is used internally to calculate inflow in pumped volume applications (P622=3 and P623=1).

Press  to toggle between percent and volume.

### Values

-999 to 9999

# Measurement Verification (P710 to P713)

## P710 (G) Fuzz Filter

*Use this feature to stabilize the reported level, due to level fluctuations (such as a rippling or splashing liquid surface), within the Echo Lock Window (P713).*

This value (in % of Span, P007) is automatically altered when Maximum Process Speed (P003) is altered.

The higher the value entered, the greater the fluctuation stabilized.

### Values

0 to 100 (0 = off)

## P711 (G) Echo Lock

*Use this feature to select the measurement verification process.*

If a material agitator (mixer) is used in the vessel monitored, set Echo Lock for "maximum verification" or "material agitator", to avoid agitator blade detection. Ensure the agitator is always "on" while the EnviroRanger is monitoring the vessel, to avoid stationary blade detection.

When set for "max verification or material agitator", a new measurement outside of the Echo Lock Window (P713), must meet the sampling criterion (P712).

For "total lock", Echo Lock Window (P713) is preset to "0". The EnviroRanger continuously searches for the best echo according to the algorithm chosen (P820). If the selected echo is within the window, the window is then centered about the echo. If not, the window widens with each successive shot until the selected echo is within the window. The window then returns to its normal width.

When Echo Lock is "off", the EnviroRanger responds immediately to a new measurement as restricted by the Max Fill / Empty Rate (P700 / P701), however measurement reliability is affected.

### Values

0	off
1	maximum verification
2	* material agitator
3	total lock

## P712 (G) Echo Lock Sampling

*The sampling criterion sets the number of consecutive echoes appearing above or below the echo currently locked onto, that must occur before the measurements are validated as the new reading (for Echo Lock P711 values: 1 or 2).*

P711 value	P712 preset value
1, max verification	5:5
2, material agitator	5:2

e.g.: P711 = 2, material agitator P712 = 5:2

This means that a new reading will not be validated unless 5 consecutive measurements higher or 2 consecutive measurements lower than the current reading occurs.

### Values

1:1 to 99:99 (x:y)

x = # of “above” echoes

y = # of “below” echoes

Resetting P711 returns P712 to the respective preset values.

## P713 (G) Echo Lock Window

*Adjusts the size of the Echo Lock Window.*

The Echo Lock Window is a “distance window” (in units, P005) centred on the echo used to derive the Reading. When a new measurement falls within the window, the window is re-centred and the new Reading is calculated. Otherwise, the new measurement is verified by Echo Lock (P711) before the EnviroRanger updates the reading.

When “0” is entered (preset) the window is automatically calculated after each measurement. For slower P003 (IT) Maximum Process Speed values the calculated window is narrow, for faster P003 values the window becomes increasingly wider.

### Values

0.000 to 9999

Preset: 0.000

# Transducer Scanning (P726 to P728)

## P726 (G) Level System Sync

*Enables the System Sync on the terminal block.*

Use this parameter if another level measurement system is mounted near the EnviroRanger and they are wired together on the Sync terminal.

See the Installation Guide for further information.

### Values

0		not required
1	*	synchronize level monitors

## P727 (G) Scan Delay

*The delay, in seconds, between measurements from transducer points.*

This feature may only be used for "differential" or "average" Operation (P001 = 4 or 5), to adjust the delay before the next point is scanned.

Enter the amount of delay in seconds. This value is automatically altered when Maximum Process Speed (P003) is altered.

### Values

0.000 to 9999  
Preset: 5.0

### Related

- P003 (IT) Maximum Process Speed on page 58

## P728 (IT) Shot Delay

*The delay, in seconds, between transducer shots.*

Use this parameter if transient acoustic noise within the vessel is causing measurement difficulties due to echoes from one shot being received on the next.

If more than one ultrasonic unit is installed for redundancy then this value should be zero "0".

### Values

0.1 to 4.0  
Preset = 0.5

## P729 (V)(IT) Scan Time

*View the elapsed time (in seconds) since the point displayed was last scanned.*

This value may be viewed as an Auxiliary Reading in the RUN mode, and is particularly useful when "differential" or "average" Operation (P001 = 4 or 5) is selected.

### Values

0.000 to 9999

## Display (P730 to P739)

### P730 (G) Auxiliary Reading





*Use this feature to display operator selected Auxiliary Readings temporarily or indefinitely (as desired).*

Select "OFF" to display Auxiliary Readings temporarily.

Select "HOLd" to display Auxiliary Readings until another Auxiliary Reading is selected or programming mode is entered.

See Hand Programmer on page 11 for run mode auxiliary readings.

To select the Auxiliary Reading operation desired...

1. Press  to display the Auxiliary Function symbol.
2. Press  or  to access the "OFF" or "HOLd" option desired.
3. Press .

If desired, also enter the Parameter Number to default in the Auxiliary Reading display. That parameter value will show in the auxiliary reading area by default. Other values are available but will reset to the parameter defined here.

#### Values

000 to 999 or "OFF", "HOLd"

### P731 (G) Auxiliary Reading Key

*Enter the Parameter Number whose value is to be displayed in the Auxiliary Reading field when...*

 is pressed in the RUN mode.

See Hand Programmer on page 11 for run mode auxiliary readings.

#### Values

000 to 999

Preset to Material Reading, P921

## P732 (G) Display Delay

*Adjusts the Point Number display scroll speed.*

Use this feature (if desired) when "differential" or "average" Operation (P001 = 4 or 5) is selected, to adjust the delay (in seconds) before the display advances to the next Point Number.

(Display scrolling is independent from transducer scanning.)

### Values

0.5 to 10 (preset to 1.5 seconds)

## P733 (G) Scroll Access

*Use this feature to select the parameter scroll access option desired.*

### off



to scroll to all parameters (P001 to P999)

### smart

for Quick Start, altered, and tagged parameters

### tagged

to scroll to operator tagged parameters only

Press  and then  to tag / untag any accessed parameter.

 is displayed to indicate the parameter accessed is tagged.

### Values

0		off
1	*	smart
2		tagged

## P735 (G) Backlight

*Controls the LCD backlighting.*

The backlight can be forced on or off or can be controlled by interaction with a programmer. If the backlight is controlled with the programmer then it will turn off 30 seconds after the last key is pressed.

### Values

0		off
1	*	on
2		keypad activated

## P736 (G) Date Format

*The order of days and months in date readings in run mode.*

This parameter determines the order of days and months of dates shown in run mode. It does not affect the way dates are set in program mode.

### Values

0	*	DD:MM
1		MM:DD

## P737 (G) Primary Reading

*The reading shown on the primary reading display when in run mode.*

When this value indicates “toggle” then both readings (default and totalizer) are shown in the time specified in display delay (P732).

### Values

1	*	default reading (P920) based on operation (P001)
2		LCD totalizer (P322, P323)
3		automatically toggle between 1 and 2

### Related

- LCD Totalizer (P322 and P323) on page 121
- P920 (IL) Reading Measurement on page 193

## P739 (G) Time Zone

*The offset from GMT (Greenwich Mean Time) of local time.*

This parameter does not affect any timed events because all times are local. It can be accessed by a remote computer for synchronization purposes.

While this parameter will accept the values shown below, valid values are – 12.00 to +12.00.

### Values

-999 to 9999  
Preset: 0.0



## SmartLinx Reserved (750 to 769)

These parameters are reserved for optional SmartLinx communications cards and vary by card. Refer to the SmartLinx documentation to determine if any of them are used.

# Communications (P770 to P782)

The EnviroRanger communication ports are setup by a series of parameters which are indexed by port. See the Communications Reference for a complete description of setting up the EnviroRanger for communications.

The parameters listed below are indexed to the two communication ports, unless otherwise noted:

Port	Description
1	RS-232 port (RJ-11 modular telephone) on front of unit
2	RS-232 port on terminal block

## P770 (IP) Protocol

*The communications protocol used between the EnviroRanger and other devices.*

The EnviroRanger supports Milltronics' proprietary "Dolphin" data format plus the internationally recognized Modbus standard in both ASCII and RTU formats.

The Milltronics protocol is compatible with the Dolphin Plus configuration program. See the Milltronics web site for information on this PC product (<http://www.milltronics.com/>).

The Modbus protocol is an open standard developed by AEG Schneider Automation Inc.

Other protocols are available with optional SmartLinx cards.

### Values

- 0 Communications port disabled
- 1 \* Milltronics "Dolphin" protocol (preset for port 1)
- 2 Modbus ASCII slave serial protocol
- 3 \* Modbus RTU slave serial protocol (preset for port 2)

## P771 (IP) Network Address

*The unique identifier of the EnviroRanger on the network.*

For devices connected with the Milltronics protocol this parameter is ignored.

For devices connected with a serial Modbus protocol this parameter is a number from 1-247. The network administrator must ensure that all devices on the network have unique addresses.

Do not use the value “0” for Modbus communications as this is the broadcast address and is inappropriate for a slave device.

### Values

0 to 9999  
Preset: 1

## P772 (IP) Baud Rate

*The communication rate with the master device.*

This parameter specifies the rate of communication in Kbaud. Any value may be entered but only the values shown below are supported.

The baud rate chosen should reflect the speed of the connected hardware and protocol used.

### Values

4.8		4800 baud
9.6		9600 baud
19.2	*	19,200 baud (preset for port 2)
115.2	*	115,200 baud (preset for port 1)

## P773 (IP) Parity

*The serial port parity.*

Ensure that the communications parameters are identical between the EnviroRanger and all connected devices.

For example many modems default to N-8-1 which is No parity, 8 data bits, and 1 stop bit.

### Values

0	*	No Parity
1		Odd Parity
2		Even Parity
3		Mark Parity (=1)
4		Space Parity (=0)

## P774 (IP) Data Bits

*The number of data bits per character.*

Protocol	P774 Value
Modbus RTU	8
Modbus ASCII	7 or 8
Dolphin Plus	7 or 8

### Values

5 to 8  
Preset: 8

## P775 (IP) Stop Bits

*The number of bits between the data bits.*

### Values

1 or 2  
Preset: 1

## P776 (IP) Port Flow Control

*The flow control used on the serial port.*

The EnviroRanger supports hardware flow control (RTS/CTS). If your connected device requires this control then select it. Otherwise, select no flow control.

### Values

0 \* No flow control  
1 RTS/CTS (Hardware flow control)

## P777 (IP) Key up Delay

*The delay, in milliseconds, between asserting RTS and transmitting the first data bit.*

This delay is built into the communications protocol to allow for older radio modems which do not buffer data and require “key up” time. Consult your modem documentation for further information.

### Values

0-3000  
Preset: 0

## P778 (IP) Modem Available

*Sets the EnviroRanger to use an external modem on the RS-232 port.*

Any connected modem must be set up to auto-answer incoming calls. The EnviroRanger does not automatically configure the modem.

### Autobaud (enabled by P778=1)

When the EnviroRanger is powered up or the P779 Modem Inactivity Timeout expires three carriage returns are sent to the modem to allow it to set its serial connection to P772 Baud Rate.

If a connection is made with the modem at a different baud rate the EnviroRanger will attempt to use that rate instead of the P772 value. For troubleshooting purposes the baud rate on the modem can be hard-coded to the rate set on the EnviroRanger. See your modem documentation for information on fixing the baud rate.

### Values

0	*	No modem connected
1		Modem connected

## P779 (IP) Modem Inactivity Timeout

*Sets the time in seconds that the EnviroRanger will keep the modem connected even though no activity is happening.*

To use this parameter ensure that P778=1.

This parameter allows for reconnection to the EnviroRanger unit after an unexpected disconnect. Ensure that the value is low enough to avoid unnecessary delays when an unexpected disconnect occurs but long enough to avoid timeout while you are still legitimately connected.

### Hanging Up

If the line is idle and the P779 Modem Inactivity Timeout expires then the modem is directed to hang up the line. This is done with the Hayes commands:

- two second delay
- +++
- two second delay
- ATH

Ensure that P779 is set longer than the standard polling time of the connected master device.

0 disables the inactivity timer.

**Values**

0-9999  
 Preset: 0

**P782 (G) Parameter Index Location**

*Determines where index information is stored for the parameter access area.*

EnviroRanger parameters can be indexed by a primary and secondary index value. These values determine which item the parameter affects. For example, a parameter which affects relays will have a primary index with five possible values, each representing a relay.

**Note:**  
 See the EnviroRanger Programming Reference (PL-566) for descriptions of all the device's parameters.

The index values can be stored in two different areas:

**Global (0)**

The primary and secondary index values are global (they affect all of the parameter access area at once) and stored in:

- primary index – R43,999
- secondary index – R43998

**Parameter-Specific (1)**

The primary and secondary index values are encoded into the format words found between R46,000 and R46,999. Each format work corresponds with the R44,000-series number in the parameter access map.

For example, the format register R46,111 corresponds to the parameter P111 and the value is stored in R44,111.

If the Modbus protocol (P770 = 2 or 3) is not used this parameter is ignored.

**Values**

0	*	Global
1		Parameter-Specific

# SmartLinX Hardware Testing

These parameters are used to test and debug an installed SmartLinX card. If there is no SmartLinX card installed in the EnviroRanger ignore these parameters.

## P790 (G) Hardware Error

*Displays the results of ongoing hardware tests within the communications circuitry.*

If any test does not meet the PASS requirements, communication halts and tests are repeated until PASS requirements are met. Communication then resumes.

### Values

PASS	*	no errors
FAIL		faulty SmartLinX module or EnviroRanger
ERR1		unknown protocol, upgrade software

## P791 (G) Bus Error

*Indicates if an error condition is occurring on the bus.*

### Values

0	*	no error
∅		error code, refer to the SmartLinX module documentation for explanation of the code

## P792 (G) Bus Error Count

*A count that increments by 1 each time a bus error (P752) is reported.*

The register is factory set at 0 and but can be preset to any value. The register is reset to 0 on a master reset (P999).

### Values

0 to 9999  
Preset: 0

# Echo Processing (P800 to P807)

## P800 (G) Near Blanking

*The space close to the transducer face which cannot be measured*

Use this feature if the surface monitored is incorrectly reported as near the transducer face and the true level is further away. Extend Near Blanking to overcome measurement difficulties which cannot be corrected by transducer relocation, mounting, or aiming.

Ensure that Span (P007) < Empty(P006) – Near Blanking (P800)

The causes of measurement difficulties which may be corrected include:

- Vessel obstruction partly blocking the transducer acoustic beam
- Transducer standpipe mount that is too narrow for its length or not cut at 30 to 45°
- Transducer mounting which is resonant at the transducer frequency (ringing)

### Values

0.000 to 9999

### Preset (minimum allowed)

0.300m	Most transducers
0.450m	XCT-8, XCT-12

### Related

- P006 (IT) Empty on page 59
- P007 (IT) Span on page 60

## P801 (G) Range Extension

*Allows the material level to fall below the Empty setting without reporting LOE.*

Use this parameter if the surface monitored can fall past the Empty (P006) level in normal operation. Range Extension is preset to 20% of Span (P007).

This feature is particularly useful for OCM applications where the Empty level is set to the bottom of the weir, and above the bottom of the channel.

The value of this parameter is added to Empty (P006) to get the full range that the EnviroRanger will accept. The full range can be greater than the range of the transducer.

If the surface monitored can extend beyond Empty (P006), increase Range Extension (in Units (P005) or % of Span) such that Empty plus Range Extension is greater than the transducer face to furthest surface to be



monitored distance. This is often the case with OCM when using weirs and some flumes.

### Values

0.000 to 9999  
20% of Span (P007)

### Related

- P006 (IT) Empty on page 59
- P007 (IT) Span on page 60
- P004 (G) Transducer on page 58

## P802 (G) Submergence Transducer

*Used when the transducer has a submergence shield attached and the transducer is expected to be submerged on occasion.*

With the submergence shield in place and the transducer submerged the trapped air pocket creates a special echo that is recognized by the EnviroRanger. It immediately advances the reading to the highest level and operates displays and outputs accordingly.

This feature is particularly useful when power is returned while the transducer is submerged.

### Values

0	*	off
1		submergence transducer

### Related

- P006 (IT) Empty on page 59
- P071 (IT) Failsafe Material Level on page 70
- Relays on page 72

## P803 (G) Shot / Pulse Mode

*Determines what type of ultrasonic shots are fired.*

Use this feature (if desired) to increase EnviroRanger response when the monitored surface is close to the transducer face.

Select "short and long" to have short and long acoustic shots fired for each measurement, regardless of the transducer to surface distance.

Select "short" to have only short shots fired if the Echo Confidence (P805) produced by a short shot exceeds the short Confidence Threshold (P804) and the monitored surface is always within the Short Shot Range (P852).

**Values**

- 1 short
- 2 \* short and long

**Related**

- P006 (IT) Empty on page 59
- P805 (V)(IT) Echo Confidence on page 178
- P804 (G) Confidence Threshold on page 178
- P852 (G) Short Shot Range on page 189

**P804 (G) Confidence Threshold**

*Determines which echoes are evaluated by software.*

Use this feature when an incorrect material level is reported.

The short and long shot Confidence Thresholds are preset to 10 and 5 respectively. When Echo Confidence (P805) exceeds the Confidence Threshold, the echo is evaluated by Sonic Intelligence™.

Values are entered as two numbers separated by a decimal point. The first number is the short shot confidence and the second number is the long shot confidence.

When you type the decimal point “.” it is replaced with a colon “:” on the display.

**Values**

- 0 to 99:0 to 99
- Preset: 10:5

**Related**

- P805 (V)(IT) Echo Confidence on page 178

**P805 (V)(IT) Echo Confidence**

*Displays the echo confidence of the measurement echo from the last shot.*

Use this feature to monitor the effect of transducer aiming, location, and mechanical transducer / mounting isolation.

Both short and long shot Echo Confidence is displayed. (To display this value in the auxiliary display while the unit is running, press  for 4 seconds).

Display	Description
"x:--"	short shot confidence value, (long shot not used).
"--:y"	long shot confidence value, (short shot not used).
"x:y"	short and long shot confidence values (both used).
"E"	transducer cable is open or short circuited.
"--:--"	no shots were processed for Sonic Intelligence™ evaluation.

### Values

x:y

x = short (0 to 99), y = long (0 to 99)

## P806 (V)(IT) Echo Strength

*Displays the strength (in dB above 1 uV RMS) of the echo which was selected as the measurement echo.*

### Values

0 to 99

## P807 (V)(IT) Noise

*Displays the average and peak ambient noise (in dB above 1 uV RMS) being processed.*

The noise level is a combination of transient acoustic noise and electrical noise (induced into the transducer cable or receiving circuitry).

See Noise Problems on page 206.

### Values

x:y

x = average (-99 to 99), y = peak (-99 to 99)

# Advanced Echo Processing (P810 to P825)

## Note:

The following parameters are for authorized Milltronics Service personnel or Instrumentation Technicians familiar with Milltronics echo processing techniques.

## Anatomy of an Echo Profile

The relevant parts of an echo profile are listed here. These are visible in either Dolphin Plus or an oscilloscope.

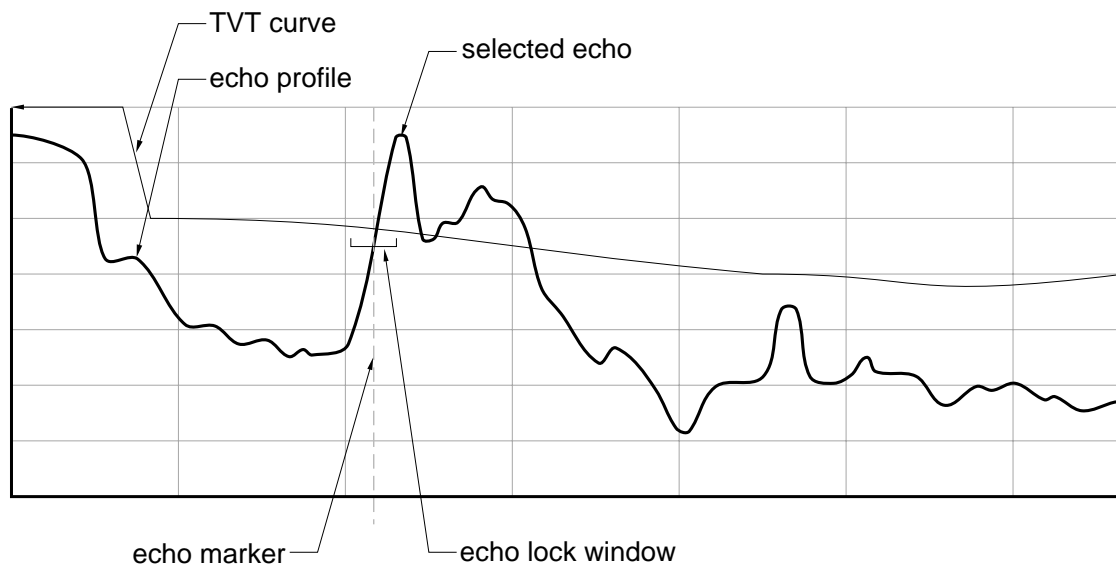

## P810 (IT) Scope Displays

*Captures echo profiles for display on an oscilloscope.*

The best way to display and compare echo profiles is by using Dolphin Plus. This software is available from your Milltronics representative.

Use this feature to monitor the effects of Echo Processing changes.

Connect an oscilloscope to Display Board TP1, TP2, and TP3.

Sweep = 10 us / div. to 1 ms / div. (x 100 for real time)

Amplitude = 1 V / div.





Trigger = external

Any combination of the following Scope Displays are available.

Display	Symbol			
	P	C	n	u
Echo Profile	▲			
TVT Curve		▲		
Echo Marker			▲	
Echo Lock Window				▲

There are two methods of selecting the Scope Displays:

### Scrolling

1. Press  to display the Auxiliary Function symbol.
2. Press  or  to access the desired Reading display symbols.
3. Press  with the desired display symbols displayed.

### 1/0 Values

Alternatively, a 4 digit binary value may be entered, where a “0” turns the associated signal display “off”, and a “1” turns the display “on”.

e.g. 1110 = PCn\_ = Echo Profile, TVT Curve, and Echo Marker displays on, Echo Lock Window display off.

See Echo Processing on page 197 for illustrations and more information.

Use the Scope Displays after pressing  (in the program mode) to observe the result of Echo Processing parameter alterations. (Take several measurements to verify measurement repeatability and overcome Echo Lock (P711) restrictions).

As preset, all displays are off.

### Values

P, C, n, u, \_  
Preset: \_ \_ \_ \_

## P816 (V)(IT) Echo Time

*The time (in ms) from the transmit pulse to the echo processed.*

### Values



0.0 to 9999

## Profile Pointer (P817 to P825)

When a Profile Pointer Parameter is accessed, the Echo Lock Window scope display changes to a Profile Pointer display. The Profile Pointer may be moved to a number of points on the Echo Profile, to gain specific information dependent upon the Profile Pointer Parameter used.

To move the Profile Pointer to a specific point, enter the desired value. The Profile Pointer will move to the nearest acceptable Echo Profile point. The Profile Pointer is preset to "0".

Alternatively, to scroll the Profile Pointer along the Echo Profile...

1. Press  to display the Auxiliary Function symbol.
2. Press  or  to move the Profile Pointer to the left or right respectively.

When the Profile Pointer Parameters are exited and is pressed or the RUN mode is entered, the Profile Pointer display automatically changes back to the Echo Lock Window display.

### P817 (V) Profile Pointer Time

*The time (in ms) from the transmit pulse to the Profile Pointer.*

#### Values

0.000 to 9999

### P818 (V) Profile Pointer Distance

*The distance (in P005 Units) between the transducer face and the Profile Pointer.*

#### Values

0.000 to 9999

### P819 (V) Profile Pointer Amplitude

*The amplitude (in dB above 1 uV) of the Echo Profile at the Profile Pointer position.*

#### Values

0 to 99





## P820 (G) Algorithm

*Chooses the algorithm used to generate the measured value from the echo profile.*

Use this feature to select the algorithm(s) which the Sonic Intelligence™ echo selection is based on. Use P805 (V)(IT) Echo Confidence (page 178) to determine which algorithm gives the highest confidence under all level conditions.

If the wrong echo is processed, select an alternate algorithm, while observing the resultant echo processing displays.

To select an Algorithm...

1. Press  to display the Auxiliary Function symbol.
2. Press  or  to access the desired Reading display symbols.
3. Press  with the desired algorithm is displayed.

Alternatively, enter the numeric value desired.

### Values

1	ALF	= flat Area, Largest, and First average
2	A	= flat Area only
3	L	= flat Largest only
4	F	= flat First only
5	AL	= flat Area and Largest average
6	AF	= flat Area and First average
7	LF	= flat Largest and First average
8	* bLF	= smooth Largest or First
9	bL	= smooth Largest only
10	bF	= smooth First only

## P821 (G) Spike Filter

*Dampens spikes in the echo profile to reduce false readings.*

Activate the Spike Filter if interference spikes are observed on the long shot Echo Profile display.

### Values

0	off
1	* on

## P822 (G) Narrow Echo Filter

*Filters out echoes of a specific width.*

Use this feature if transducer acoustic beam interference (e.g. ladder rungs) is processed.

Enter the width of false echoes (in ms), to be removed from the long shot Echo Profile.

When a value is keyed in, the nearest acceptable value is entered.

### Values

0 = off (preset), greater = wider

## P823 (G) Reform Echo

*Smooths jagged peaks in the echo profile.*

Use this feature, when monitoring solids (P002 = 2), if the reported level fluctuates slightly, though the monitored surface is still).

Enter the amount (in ms) of long shot Echo Profile smoothing required.

When a value is keyed in, the nearest acceptable value is entered.

### Values

0 = off (preset), greater = wider

## P825 (G) Echo Marker Trigger

*Specifies the point on the primary echo on which the measured value is based.*

Use this feature if the reported material level fluctuates slightly, due to a variable rise in the leading edge of the true echo on the Echo Profile.

Enter the value (in percent of echo height) to ensure the Echo Lock Window intersects the Echo Profile at the sharpest rising portion of the Echo Profile representing the true echo. This value is preset to 50%.

### Values

5 to 95%



# Advanced TVT Adjustment (P830 to P835)

**Note:**

The following parameters are for authorized Milltronics Service personnel or Instrumentation Technicians familiar with Milltronics echo processing techniques.

## P830 (G) TVT Type

*Selects the TVT Curve used.*

This feature is automatically altered when Material (P002) is altered. Do not use "TVT Slopes" with the "bF" or "bLF" Algorithm (P820).

Select the TVT type which gives the highest confidence (P805) under all level conditions. Use this parameter with caution.

**Values**

- |   |                       |
|---|-----------------------|
| 1 | TVT Short Curved      |
| 2 | TVT Short Flat        |
| 3 | TVT Long Flat         |
| 4 | TVT Long Smooth Front |
| 5 | TVT Long Smooth       |
| 6 | TVT Slopes            |

## P831 (G) TVT Shaper

*Turns the TVT Shaper "on" or "off".*

Turn the TVT Shaper "on" before altering TVT Shaper Adjust. After using TVT Shaper Adjust (to avoid a false echo or pick up the true echo), turn the TVT Shaper "on" and "off" while monitoring the effect.

**Values**

- |   |   |     |
|---|---|-----|
| 0 | * | off |
| 1 |   | on  |

## P832 (IB) TVT Shaper Adjust

*Allows manual adjustment of the TVT curve.*





Use this feature to bias the shape of the TVT curve to avoid crossing false echoes from fixed objects.

Adjustment to this parameter is best done while viewing the echo profile with Dolphin Plus. Refer to the Dolphin Plus online help for details on using the software.

If Dolphin Plus is not available then an oscilloscope can be used. When using an oscilloscope, the Echo Lock Window display becomes the TVT Curve Pointer. See P810 (IT) Scope Displays on page 180 for more information.

The TVT curve is divided into 40 breakpoints, accessible by enabling the point number as the breakpoint index field. Each breakpoint is normalized to a value of 0, as displayed in the parameter value field. By changing the breakpoint value, up or down, the intensity of the bias applied to that breakpoint of the curve is respectively changed. By changing the value of adjacent breakpoints, the effective bias to the shaper can be broadened to suit the desired correction. In the case of multiple false echoes, shaping can be applied along different points of the curve. Shaping should be applied sparingly in order to avoid missing the true echo.

To change a breakpoint ...

1. Go to P832
2. Press  twice to highlight the index value
3. Press  or  to scroll through the 40 points (or type in the desired point)
4. Enter the value from -50 to 50
5. Press 

P831, TVT shaper, must be `on'.

#### Values

-50 to 50  
Preset: 0

#### Related

- P831 (G) TVT Shaper on page 185

## P833 (G) TVT Start Min

*Use this feature to adjust the TVT Curve height to ignore false echoes (or pick up true echoes) near the start of the Echo Profile.*

Enter the minimum TVT Curve start point (in dB above 1 uV RMS).

This feature should only be used if increased Near Blanking (P800) would extend farther than desired into the measurement range.

#### Values

30 to 225 (preset = 50)

## P834 (G) TVT Start Duration

*Use this feature in conjunction with TVT Start Min (P833) to ignore false echoes (or pick up true echoes) near the start of the Echo Profile.*

Enter the time (in ms) for the TVT Curve to decrease from the TVT Start Min (P833) point to the TVT Curve baseline.

**Values**

0 to 9999 (preset = 30)

## **P835 (G) TVT Slope Min**

*Enter the minimum slope (in dB/s) for the middle of the TVT Curve.*

This feature (preset to 200) is used in conjunction with TVT Start Duration (when a long flat TVT Type is selected) to ensure the TVT Curve remains above false echoes which appear in the middle of the Echo Profile.

Alternatively, if TVT Type is set for "TVT Slopes" (P830 = 6), this value is preset to 2000. Use this feature to adjust the slope declination, as required.

**Values**

0 to 9999 (preset = 200)

# Advanced Shot Adjustment (P840 to P852)

**Note:**

These parameters are for Milltronics service personnel only.

## P840 (G) Short Shot Number

Enter the number of short shots to be fired (and results averaged) per transmit pulse.

**Values**

0 to 100

Preset: 1

## P841 (G) Long Shot Number

Enter the number of long shots to be fired (and results averaged) per transmit pulse.

This value is automatically altered by Maximum Process Speed (P003).

**Values**

0 to 200

Preset: 5

## P842 (G) Short Shot Frequency

Adjust the short shot transmit pulse frequency (in kHz).

This feature is automatically altered when Transducer (P004) is altered.

**Values**

10.00 to 60.00

## P843 (G) Long Shot Frequency

Adjust the long shot transmit pulse frequency (in kHz).

This feature is automatically altered when Transducer (P004) is altered.

**Values**

10.00 to 60.00

## P844 (G) Short Shot Width

Adjust the width (in ms) of the short shot transmit pulse.

This feature is automatically altered when Transducer (P004) is altered.

### Values

0.000 to 5.000

## P845 (G) Long Shot Width

Adjust the width (in ms) of the long shot transmit pulse.

This feature is automatically altered when Transducer (P004) is altered.

### Values

0.000 to 5.000

## P850 (G) Short Shot Bias

Use this feature to slant the echo evaluation in favour of the short shot echo when both short and long shots are evaluated (see Shot Mode, P803).

### Values

0 to 100  
Preset: 20

## P851 (G) Short Shot Floor

Enter the minimum echo strength (in dB above 1 uV), derived from a short shot, to be considered for evaluation.

### Values

0 to 100  
Preset: 50

## P852 (G) Short Shot Range

Enter the maximum distance in Units (P005) to be measured using short shot echoes.

This feature is automatically altered when Transducer (P004) is altered.

### Values

0.000 to 9999

# Test (P900 to P913)

**Note:**

Test Parameters are intended for use by Milltronics Service personnel.

## P900 (V) Software Revision #

View the EPROM Rev. #.

**Values**

00.00 to 99.99

## P901 (V) Memory

Press  to activate the EnviroRanger memory test.

**Values**

PASS	(memory test successful)
F1	RAM
F2	NOVRAM
F3	FLASH data
F4	FLASH code

## P902 (V) Watchdog

Press  to put the CPU into an infinite loop to test the watchdog timer.

On successful completion (10 seconds) the RUN mode is entered and the EnviroRanger is reset. Programming is kept and the unit responds as if there had been a power failure.

## P903 (V) Display

Press  to activate the display test.

All LCD segments and symbols are temporarily displayed.

## P904 (G) Keypad

Press each keypad key in the following sequence:



As each key is pressed, the associated keypad number is displayed. On successful test completion, "PASS" is displayed. "FAIL" is displayed if a key is pressed out of sequence or the programmer keypad malfunctions.

## P905 (IT) Transmit Pulse

Press  to supply repeated transmit pulses, at the frequency entered, to the transducer and / or view the transducer operating frequency (automatically altered by (P004) Transducer) for the Point Number displayed.

This feature may be used to monitor the transmit pulse with an oscilloscope connected to the transducer terminals.

### Values

10.00 to 60.00

## P906 (G) Rear RS-232 Port

Press  to test the RS-232 port on the terminal block.

On successful test completion, "PASS" is displayed. Otherwise, "FAIL" is displayed. An external device must be connected to the RS-232 port for this test to pass.

## P907 (G) Infrared Interface

Press  to activate the programmer interface (two way infrared communications) test.

On successful test completion, "PASS" is displayed. Otherwise, "FAIL" is displayed.

## P909 (G) Front RS-232 Port

Press  to test the RS-232 port on the front of the unit.

On successful test completion, "PASS" is displayed. Otherwise, "FAIL" is displayed. An external device must be connected to the RS-232 port for this test to pass.

## P912 (IT) Transducer Temperature

Use this feature to display the temperature in °C (as monitored by the connected transducer). "Err" is displayed if the transducer is not equipped with an internal temperature sensor.

### Values

-50 to 150

## P913 (G) Sensor Temperature

Access this parameter to display the temperature in °C (as monitored by the TS-3). "OPEn" is displayed if a TS-3 is not connected.

### Values

-50 to 150

## P914 (G) mA Input

Use this feature to display the mA input value (in mA).

### Values

0.000 to 24.00



## Measurement (P920 to P927)

Use these parameters to verify EnviroRanger programming. All of these parameters are available in run mode. See Readings in Run Mode on page 12 for more information.

The range and values shown for each of these parameters depends on the Operation (P001) chosen. The readings for each operation are listed below.

### To Access in Run Mode

1. Ensure the device is in run mode
2. Press The Auxiliary Reading field becomes underscores P\_ \_ \_
3. Type the parameter number  
The field changes to the value of the specified parameter

These parameters are also available in simulation mode. See Simulation on page 49 for instructions on how to control the simulation direction and rate.

## P920 (IL) Reading Measurement

*Corresponds to the final reading after all EnviroRanger programming is applied.*

In general this means that:  $P920 = \text{Reading} \times P060 + P061$

### Reading Measurements by Operation

P001	P050 = 0	P050 ≠ 0
0 – Off	----	----
1 – Level	P921	P924
2 – Space	P922	100% - P924
3 – Distance	P927	P927
4 – Difference	P921 (indexed)	P921 (indexed)
5 – Average	P921 (indexed)	P921 (indexed)
6 – OCM	P925	P925
7 – Pump Totalizer	P925	P925

### Values

-999 to 9999

## P921 (IL) Material Measurement

*Corresponds to the distance, in units (P005) or percent of span (P007), between Empty (P006) and the monitored surface.*

### Values

-999 to 9999

## P922 (IT) Space Measurement

*Corresponds to the distance, in units or percent, between the monitored surface and Span (P007).*

### Values

0.000 to 9999

## P923 (IT) Distance Measurement

*Corresponds to the distance, in units, between the monitored surface and the transducer face.*

### Values

0.000 to 9999

## P924 (G) Volume Measurement

*Corresponds to the calculated vessel capacity used displayed in Max Volume (P051) units or % of Max Volume.*

### Values

0.000 to 9999

## P925 (G) Flow Measurement

*Corresponds to the calculated flowrate in Max Flow (P604) units or % of Max Flow.*

### Values

0.000 to 9999

## P926 (G) Head Measurement

*Corresponds to Head (the distance from Zero Head (P605) to the monitored surface) in Units (P005) or % of Span (P007).*

### Values

-999 to 9999

## P927 (IT) Distance Measurement

*Corresponds to the distance, in units (P005) or percent of empty (P006), between the monitored surface and the transducer face.*

Use P923 unless the distance information is required in percent of span.

### Values

0.000 to 9999

# Master Reset (P999)

## P999 (G) Master Reset

This feature resets all parameters to original values.

Use this feature prior to initial programming if arbitrary Parameter Values were used during a "bench test", or after upgrading the EnviroRanger software.

Following a Master Reset, complete reprogramming is required.

To perform a Master Reset...

1. Press
2. Press

"C.ALL" is displayed until the reset is complete.

# Appendix A – Technical Reference

---

## Transmit Pulse

The EnviroRanger transmit pulse consists of one or more electrical “shot” pulses, which are supplied to the Transducer connected to the EnviroRanger terminals.

The transducer fires an acoustic “shot” for each electrical pulse supplied. After each shot is fired, sufficient time is provided for echo (shot reflection) reception, before the next (if applicable) shot is fired. After all shots of the transmit pulse are fired, the resultant echoes are processed.

The transmit pulse shot number, frequency, duration, delay, and associated measurement range are defined by parameters P803 and P840 to P852.

## Echo Processing

Echo processing consists of echo enhancement, true echo selection, and selected echo verification.

Echo Enhancement is achieved by filtering (P821 and P822) and reforming (P823) the echo profile (P810).

The true echo (echo reflected by the intended target) is selected when that portion of the echo profile meets the evaluation criteria of Sonic Intelligence™.

Insignificant portions of the echo profile outside of the measurement range (Span P006 + Range Extension P801), below the TVT Curve (P830, and P832 to P835), and less than the Confidence Threshold (P804) and Short Shot Floor (P851) are automatically disregarded.

The remaining portions of the Echo Profile are evaluated using the Algorithm (P820) and Short Shot Bias (P850). The Echo Profile portion providing the best Echo Confidence (P805), is selected.

True echo verification is automatic. The position (relation in time after transmit) of the “new” echo, to the previously accepted echo position, is compared. When the new echo is within the Echo Lock Window (P713), it is accepted and displays, outputs, and relays are updated per the Fuzz Filter (P710) and Rate Parameters (P700 to P703). If the new echo is outside of the Echo Lock Window, it is not accepted until Echo Lock (P711) requirements are satisfied.

## Scope Display (P810)

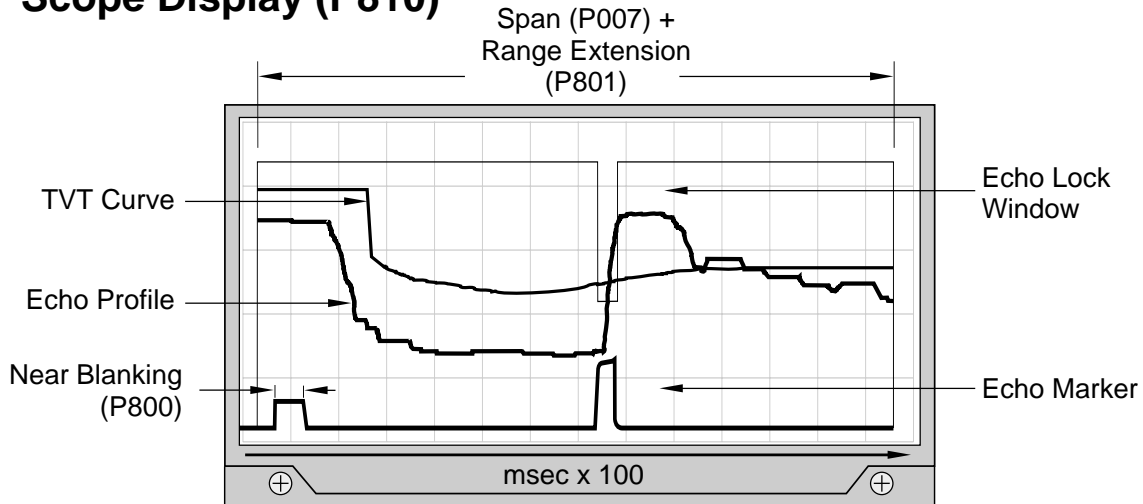

## Dolphin Plus Display

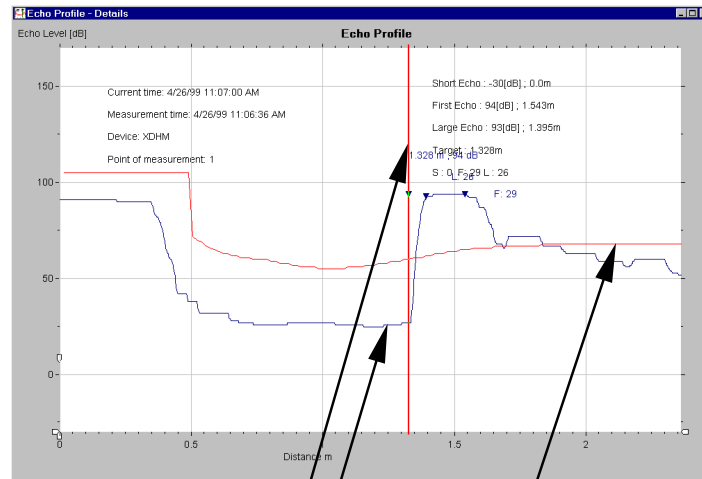

Technical Reference

echo marker  
 echo profile  
 TVT curve

## Distance Calculation

To calculate the transducer to material level (object) distance, the transmission medium (atmosphere) sound velocity (P653) is multiplied by the acoustic transmission to reception time period. This result is divided by 2 to calculate the “one way” distance.

$$\text{Distance} = \text{Sound Velocity} \times \text{Time} / 2$$

The Reading displayed is the result of performing any additional modification to the calculated distance (as determined by Operation P001, Units P005, Volume Conversion, P050 to P054, Reading, P060 to P063, OCM, P600 to P611, and/or Totalizer P622 to P633 parameters).

# Sound Velocity

The sound velocity of the transmission medium is affected by the type, temperature, and vapour pressure of the gas or vapour present. As preset, the EnviroRanger assumes the vessel atmosphere is air at 20 °C (68 °F). Unless altered, the sound velocity used for the distance calculation is 344.1 m / s (1129 ft / s).

Variable air temperature is automatically compensated when a Milltronics ultrasonic / temperature transducer is used. If the transducer is exposed to direct sunlight, use a sunshield or better yet, a separate TS-3 temperature sensor.

Also, if the temperature varies between the transducer face and the liquid monitored, use a TS-3 temperature sensor, (submerged in the liquid) in combination with an ultrasonic / temperature transducer. Set Temp Source (P660) for “both”, to average the transducer and TS-3 temperature measurements.

Atmosphere composition other than air can pose a challenge for ultrasonic level measurement. However, excellent results may be obtained if the atmosphere is homogeneous (well mixed), at a fixed temperature, and consistent vapour pressure, by performing a Sound Velocity Calibration (P651).

The EnviroRanger automatic temperature compensation is based on the sound velocity / temperature characteristics of “air” and may not be suitable for the atmosphere present. If the atmosphere temperature is variable, perform frequent Sound Velocity Calibrations to maintain optimum measurement accuracy.

Sound Velocity calibration frequency may be determined with experience. If the sound velocity in two or more vessels is always similar, future calibrations may be performed on one vessel and the resultant Velocity (P653) entered directly for the other vessel(s).

If the sound velocity of a vessel atmosphere is found to be repeatable at specific temperatures, a chart or curve may be developed. Then, rather than performing a Sound Velocity Calibration each time the vessel temperature changes significantly, the anticipated Velocity (P653) may be entered directly.

## Scanning

When the EnviroRanger is programmed for “differential” or “average” level Operation (P001 = 4 or 5), two transducers must be used. In this case, the transmit pulse is time shared between the transducers via the “Scanner” relay.

When echo processing is complete, (if more than 1 vessel is monitored) the scanning relay changes state to supply the transmit pulse to the other transducer after the Scan Delay (P727).

Scan Delay is automatically set by Maximum Process Speed (P003). When high speed scanning is required (sometimes the case for equipment position monitoring), the Scan Delay may be reduced. Reduce the Scan Delay only as required, otherwise premature scanning relay fatigue could occur.

## Volume Calculation

The EnviroRanger provides a variety of volume calculation features (P050 to P055).

If the vessel does not match any of the 8 preset Tank Shape calculations, a Universal Volume calculation may be used. Use the level/volume graph or chart provided by the vessel fabricator (or create one based on the vessel dimensions).

Based on the graph, choose the Universal Volume calculation, and select the level vs. volume breakpoints to be entered (32 max). Generally, the more breakpoints entered, the greater the volume calculation accuracy.

### Universal, Linear (P050 = 9)

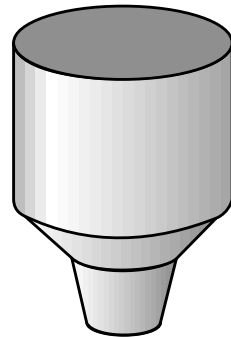
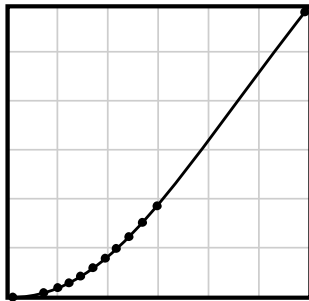

This volume calculation creates a piece-wise linear approximation of the level/volume curve. This option provides best results if the curve has sharp angles joining relatively linear sections.

Enter a Level Breakpoint at each point where the level/volume curve bends sharply (2 minimum).

For combination curves (mostly linear but include 1 or more arcs), enter numerous breakpoints along the arc, for best volume calculation accuracy.

See also: Checking Volume Characterization on page 50.



## Universal, Curved (P050 = 10)

This calculation creates a cubic spline approximation of the level/volume curve, providing best results if the curve is non-linear, and there are no sharp angles.

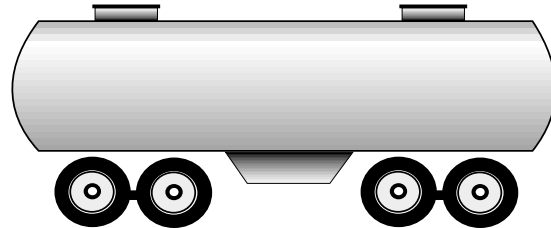
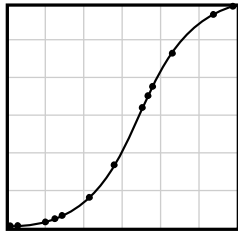

Select at least enough breakpoints from the curve to satisfy the following:

- 2 breakpoints very near the minimum level
- 1 breakpoint at the tangent points of each arc
- 1 breakpoint at each arc apex
- 2 breakpoints very near the maximum level

For combination curves, enter at least 2 breakpoints immediately before and after any sharp angle (as well as 1 breakpoint exactly at the angle) on the curve.

See also: Checking Volume Characterization on page 50.

## Flow Calculation

The EnviroRanger provides numerous OCM flow calculation features (P600 to P611).

If the PMD (primary measuring device) does not match any of the 8 preset PMD calculations, or if a PMD is not used, select a Universal Volume calculation. Use the head/flow graph or chart provided by the PMD fabricator (or create one based on the PMD or channel dimensions).

Based on the graph, choose the Universal Flow calculation, and select the head Vs flow breakpoints to be entered (32 max). Generally, the more breakpoints entered, the greater the flow calculation accuracy.

## Universal, Linear (P600 = 4)

This flow calculation creates a piece-wise linear approximation of the head/flow curve. This option provides best results if the curve has sharp angles joining relatively linear sections.

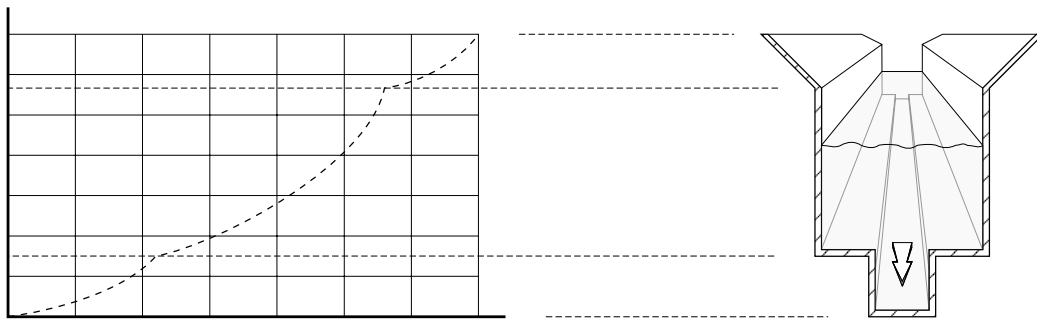

Enter a Head Breakpoint at each point where the head/flow curve bends sharply (2 minimum). For combination curves (mostly linear but include 1 or more arcs), enter numerous breakpoints along the arc, for best flow calculation accuracy.

See also: Checking OCM Flow Characterization on page 50.

## Universal, Curved (P600 = 5)

This calculation creates a cubic spline approximation of the head/flow curve, providing best results if the curve is non-linear, and there are no sharp angles.

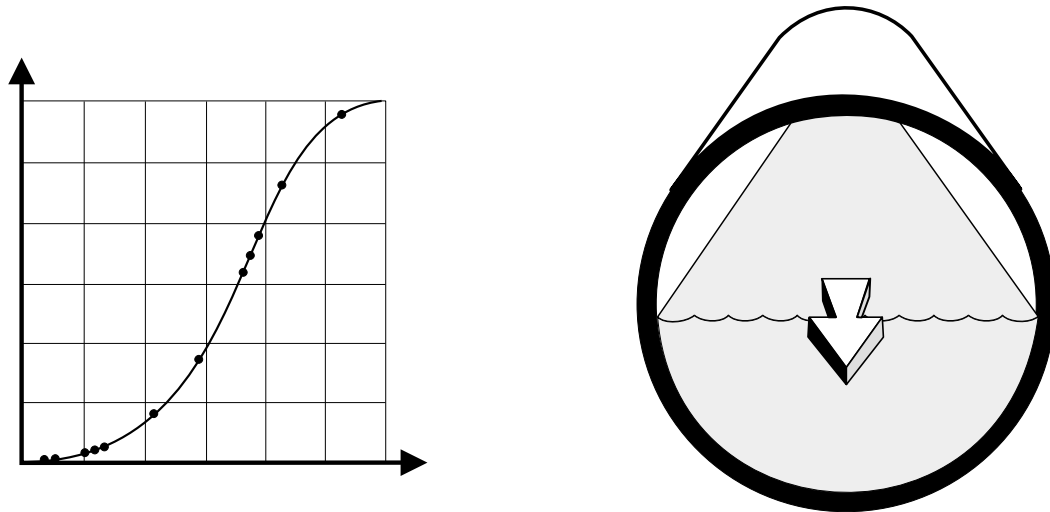

Select at least enough breakpoints from the curve to satisfy the following:

- 2 breakpoints very near the minimum head
- 1 breakpoint at the tangent points of each arc
- 1 breakpoint at each arc apex
- 2 breakpoints very near the maximum head

For combination curves, enter at least 2 breakpoints immediately before and after any sharp angle (as well as 1 breakpoint exactly at the angle) on the curve. See also: Checking OCM Flow Characterization on page 50.

# Maximum Process Speed

The EnviroRanger's ability to respond to material level changes is designed to exceed even the most demanding installation requirements.

The Maximum Process Speed setting automatically presets various parameters affecting the EnviroRanger response to material level changes as follows:

Parameter (units)	Values Dependent on Maximum Process Speed (P003)		
	1 (slow)	2 (medium)	3 (fast)
P070 Failsafe Timer (min)	100	10	1
P700 Max Fill Rate (m/min)	0.1	1	10
P701 Max Empty Rate (m/min)	0.1	1	10
P702 Filling Indicator (m/min)	0.01	0.1	1
P703 Emptying Indicator (m/min)	0.01	0.1	1
P704 Rate Filter (option)	4	2	2
P710 Fuzz Filter (% of Span)	100	50	10
P713 Echo Lock Window	(per P701 / P702 and time since last valid measurement).		
P727 Scan Delay (seconds)	5	5	3
P841 Long Shot Number	10	5	2

If any of these parameters are independently altered, a Maximum Process Speed (P003) parameter alteration automatically resets the independently altered value.

Slower Maximum Process Speed (P003) provides greater measurement reliability. Faster independently set Max Fill (P700) and Max Empty (P701) Rates may be impeded by Echo Lock (P711), Scan Delay (P727) and Shot Delay (P728) values.



# Appendix B – Troubleshooting

**Note:**

Many of the parameters and techniques described here require extensive knowledge of ultrasonic technologies and Milltronics echo processing software. Use this information with caution.

If the EnviroRanger setup becomes too confusing use P999 to reset the parameters and start again.

## Common Problems Chart

Symptom	Cause	Action
Display blank, transducer not pulsing.	No power.	Check power supply, wiring, or power fuse.
No response to programmer.	Obstructed infrared interface, defective programmer, exhausted programmer battery.	Check programmer usage: <ul style="list-style-type: none"> <li>• 15 cm (6") from faceplate</li> <li>• pointed at upper target</li> </ul> Or, check battery
Displays "Short" and "tb:(#)".	Short circuited transducer cable, or defective transducer at indicated terminal block number.	Repair or replace as necessary.
Displays "Open" and "tb:(#)".	Transducer not connected or connection reversed	Check connection to displayed terminal blocks
	Open circuited transducer cable, or defective transducer at indicated terminal block number.	Repair or replace as necessary.
Displays "LOE".	Weak or non-existent echo.	Relocate and/or re-aim transducer at material.
		Proceed to Measurement Difficulties (page 209).
Displays "Error" and "tb:(#)".	Transducer connected backwards.	Reverse black and white wires on terminal block.
	Transducer connected in "two wire" method.	Do not tie white and shield together, use all three terminal blocks.
	Wrong transducer selected (P004).	Verify transducer type and re-enter value.

Troubleshooting

Symptom	Cause	Action
Displays "EEEE".	Value too large to display in 4 or 5 characters.	Select larger Units (P005), or lower Convert Reading (P061).
Reading fluctuates while material level is still, (or vice versa).	Incorrect measurement stabilization.	Alter Maximum Process Speed (P003) or damping (P704) accordingly. See Maximum Process Speed on page 203.
Reading is fixed, regardless of the actual material level.	Transducer acoustic beam obstructed, standpipe too narrow, or transducer ringing (reads over 100%).	Relocate and / or re-aim transducer at material level or object.
		Proceed to Measurement Difficulties below.
		See also: Transducer Ringing on page 214.
Material level reported is always "off" by the same amount.	Incorrect Empty (zero) reference for level operation (P001 = 1).	See Empty (P006), Reading Offset (P063), Offset Calibration (P650), & Offset Correction (P652).
Measurement accuracy improves as level nears transducer.	Incorrect Sound Velocity used for distance calculation.	Use a transducer with a built-in temperature sensor or a TS-3 temperature sensor.
		See Sound Velocity on page 199.
Reading is erratic, with little or no relation to material level.	True echo too weak or wrong echo being processed.	Relocate and / or re-aim transducer at material.
		Check noise parameters. See Noise Problems on page 206.
Pump relay icon ( ● ) is flashing and pump does not run.	Pump has been removed from duty schedule.	Review Appendix C – Pump Control on page 215 for discrete inputs used as pump interlocks.

## Noise Problems

Incorrect readings can be the result of noise problems, either acoustic or electrical, in the application.

The noise present at the input to the ultrasonic receiver can be determined by viewing parameter P807. The display reads ##:##, where the first number is the average noise, and the second is the peak noise. In general, the most useful value is the average noise.

With no transducer attached the noise is under 5 dB. This is often called the noise floor. If the value with a transducer attached is greater than 5 dB, then signal processing problems can occur. High noise decreases the maximum

distance that can be measured. The exact relationship between noise and maximum distance is dependent on the transducer type and the material being measured. Any noise level greater than 20 dB is probably cause for concern unless the distance is much shorter than the maximum for the transducer.

## Determine the Noise Source

Disconnect the transducer from the EnviroRanger. If the measured noise is below 5 dB, then continue here. If the measured noise is above 5 dB go to Non-Transducer Noise Sources on page 208.

1. Connect only the shield wire of the transducer to the EnviroRanger.

If the measured noise is below 5 dB, continue with the next step. If the noise is above 5 dB, go to Common Wiring Problems on page 208.

2. Connect the white and black transducer wires to the EnviroRanger.

Record the average noise.

3. Remove the positive wire of the transducer.

Record the average noise.

4. Re-connect the positive wire and remove the negative wire.

Record the average noise.

Using the table below, determine the appropriate next step. The terms higher, lower and unchanged refer to the noise recorded in the previous steps.

These are guidelines only. If the suggested solution does not solve the problem, try the other options also.

	- removed	+ removed	Go to ...
noise	higher	higher	Reducing Electrical Noise
		unchanged	Common Wiring Problems
		lower	Reducing Acoustical Noise
	unchanged	higher	Reducing Electrical Noise
		unchanged	Contact Milltronics
	lower	lower	Reducing Acoustical Noise
lower	higher	Common Wiring Problems	
	unchanged	Common Wiring Problems	
	lower	Reducing Acoustical Noise	

## Acoustical Noise

To confirm that the problem is acoustical, place several layers of cardboard over the face of the transducer. If the noise is reduced, the noise is definitely acoustical.

## Non-Transducer Noise Sources

Remove all input and output cables from the EnviroRanger individually while monitoring the noise. If removing a cable reduces the noise, that cable may be picking up noise from adjacent electrical equipment. Check that low voltage cables are not being run adjacent to high voltage cables, or near to electrical noise generators such as variable speed drives.

Filtering cables is an option but is not recommended unless all other options have been exhausted.

The EnviroRanger is designed to work near heavy industrial equipment such as variable speed drives. Even so, it should not be located near high voltage wires or switch gear.

Try moving the electronics to a different location. Often moving the electronics a few meters farther from the source of noise will fix the problem. Shielding the electronics is also an option, but it should be a last resort. Proper shielding is expensive and is difficult to install properly – the shielding box must enclose the EnviroRanger electronics completely, and all wires must be brought to the box through grounded metal conduit.

## Common Wiring Problems

- Make sure that the transducer shield wire is connected at the electronics end only. Do not ground it at any other location.
- Do not connect the transducer shield wire to the white wire.
- The exposed transducer shield wire must be as short as possible.
- Connections between the wire supplied with the transducer, and any customer installed extension wire should be done in grounded metal junction boxes.

On Milltronics transducers the white wire is negative and the black wire is positive. If the extension wire is colored differently, make sure that it is wired consistently.

Extension wire must be shielded twisted pair. See the installation manual for specifications.



## Reducing Electrical Noise

- Ensure that the transducer cable does not run parallel to other cables carrying high voltage or current.
- Move the transducer cable away from noise generators such as variable speed drives.
- Put the transducer cable in grounded metal conduit.
- Filter the noise source.

## Reducing Acoustical Noise

- Move the transducer away from the noise source.
- Use a stilling well.
- Install a rubber bushing between the transducer and the mounting surface.
- Relocate or insulate the noise source.
- Change the frequency of the noise. The EnviroRanger is only sensitive to noise between 25 KHz and 65 KHz.

## Measurement Difficulties

If the Failsafe Timer (P070) expires due to a measurement difficulty, "LOE" flashes alternately with the last known Reading. In rare cases, the EnviroRanger may "lock on" to a false echo and report a fixed or wrong Reading.

### Flashing "LOE" Display

The loss of echo (LOE) display appears when the echo confidence is below the threshold value set in P805 Echo Confidence. This happens when:

- The echo is lost and no echo is shown above the ambient noise
- Two echos are too similar to differentiate

If "LOE" is displayed, ensure the:

- Surface monitored is within the transducer maximum range
- Transducer model (P004) matches the transducer used
- Transducer is located and aimed properly
- Transducer is not submerged without a submergence shield

## Adjust Transducer Aiming

See the Transducer manual for range, mounting, and aiming details. For optimum performance, adjust transducer aiming to provide the best Echo Confidence (P805) and Echo Strength (P806) for all material levels within the measurement range.

The most efficient method of checking echos is with Milltronics' Dolphin Plus software.

### To display echos...

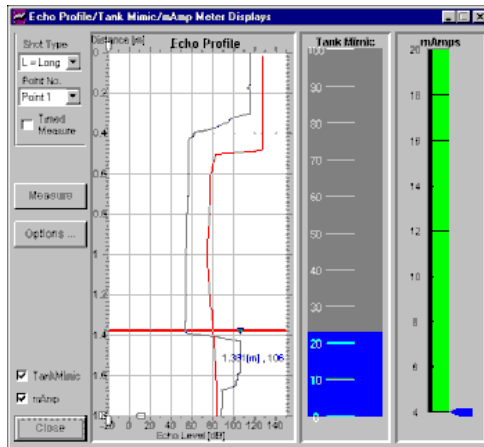

### To edit parameters...

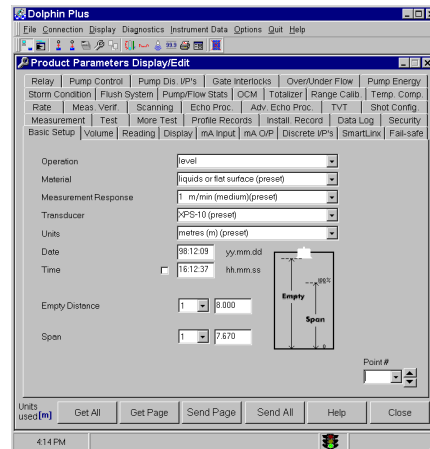

Use Dolphin Plus to graphically display the echo profile at the installation. Interpret the echo profile and change relevant parameters.

Edit the parameter values. Use F1 to get online help at any time.

### To display Echo Confidence in the RUN mode...

Press  and hold for 4 seconds (Failsafe Time Left changes to the Short:Long Confidence display).

To display Echo Confidence in the program mode, access the Echo Confidence (P805) parameter.

To update the value displayed after each aiming adjustment...

Press  (5 times or more to verify stability and overcome any echo lock P711)

### Increase Failsafe Timer Value

Increase the Failsafe Timer (P070) value, if failsafe operation will not be compromised by the larger value.

Try this only if LOE shows for short periods of time.

## Install a Transducer with a Narrower Beam

Sometimes the interference echos from the sides of a vessel can cause the EnviroRanger to lock onto a consistent, incorrect level. Try installing a longer range (narrower beam) transducer, enter the new transducer model (P004), and (if necessary) optimize aiming and frequency again.

Always contact your Milltronics service personnel before selecting a transducer to solve this type of problem.

## Use Dolphin Plus to Debug Echo

If a narrower beam transducer is not available, use Dolphin Plus to view live sonic profiles and make adjustments to the Advanced Echo Processing (P810 to P825) parameters found on page 180.

If you do not own Dolphin Plus, connect an oscilloscope and use the hand programmer to adjust the same parameters.

## Fixed Reading

If the Reading is a fixed value, regardless of the transducer to material surface distance, ensure the:

1. Transducer acoustic beam is free from obstruction.
2. Transducer is properly aimed
3. Transducer is not in contact with any metal object.
4. Material mixer (if used) is operating while the EnviroRanger is operating. If it is stopped, ensure that the mixer blade is not stopped under the transducer.

## Obstructions in the Sound Beam

Check for (and remove if present) any acoustic beam obstruction, or relocate the transducer.

If an obstruction cannot be removed or avoided, adjust the Time Varying Threshold (TVT) Curve to reduce the Echo Confidence derived from the sound reflected by the obstruction. Use Dolphin Plus to adjust the TVT curve or use an oscilloscope and a hand programmer to adjust the required parameters. (See Scope Displays, P810 and TVT Shaper, P832).

## Standpipe Mountings

If the transducer is mounted on or in a standpipe, grind smooth any burrs or welds on the inside or open end, (the end that opens into the vessel). If the problem persists, install a larger diameter or shorter length standpipe, bevel the inside of the bottom end, or cut the open end of the standpipe at a 45 angle.

See the transducer manual for complete mounting instructions.

For "ST-series" and XPS-10 transducers use the plastic conduit / flange adapter supplied with the unit.

If the mounting hardware is overtightened, loosen it. Overtightening changes the resonance characteristics of the transducer and can cause problems.

## Set the EnviroRanger to Ignore the Bad Echo

If the preceding remedies have not fixed the problem, the false echo has to be ignored.

### If the Echo is Close to the Transducer

If there is a static, incorrect, high level reading from the EnviroRanger there is probably something reflecting a strong echo back to the transducer. If the material level never reaches that point extend the Near Blanking (P800) to a distance to just past the obstruction.

### Adjust the TVT to Ignore the Echo

If increasing Near Blanking is unacceptable then the TVT Curve must be raised in the area of the false echo to ignore the false echo.

Use Dolphin Plus to view live sonic profiles and make adjustments to the TVT curve.

If you do not own Dolphin Plus, connect an oscilloscope and use the hand programmer to adjust the same parameters.

Continue making minor TVT Curve adjustments and taking new measurements while observing the Echo Marker position until the Echo Lock Window repeatedly locks onto the true echo. Verify the false echo is still ignored, regardless of the vessel material level, or empty / fill activity. Finally, ensure that the true material level can still be measured in the area where the TVT was adjusted.

# Wrong Reading

If the Reading is erratic, or jumps to some incorrect value periodically, ensure the:

1. Surface monitored is not beyond the EnviroRanger's programmed range or the transducer's maximum range
2. Material is not falling into the transducer's acoustic beam
3. Material is not inside the blanking distance of the transducer

## Types of Wrong Readings

If a periodic wrong Reading is always the same value, see Fixed Reading.

If the wrong Reading is random, ensure the material surface to transducer distance is less than the Empty value entered plus 20%. If the material/object monitored is outside this distance, increase Range Extension (P801) as required. This error is most common in OCM applications using weirs.

## Liquid Splashing

If the material monitored is a liquid, check for splashing in the vessel. Enter a lower Maximum Process Speed (P003) value to stabilize the Reading, or install a stilling well. (Contact Milltronics or your local distributor).

## Adjust the Echo Algorithm

Use Dolphin Plus to view live sonic profiles and make adjustments to the P820 (G) Algorithm parameter found on page 183.

If you do not own Dolphin Plus, connect an oscilloscope and use the hand programmer to adjust the same parameter.

If the "Area" algorithm is used and narrow noise spikes are evident on the (long shot) Echo Profile, turn the Spike Filter (P821) on and/or widen the Narrow Echo Filter (P822). Also, if the true echo has jagged peaks, use Reform Echo (P823).

If multiple echoes appear on the Echo Profile, typical of a flat material profile (especially if the vessel top is domed), use the "first" Algorithm.

If the Echo Profile repeatedly switches from short to long, adjust the Short Shot Range (P852) to stabilize the "shot" mode used for the echo evaluation. Also, adjust the Short Shot Bias to increase (or decrease the amount of preference given to short shot echoes over long shot echoes.

Should a stable measurement still not be attainable, contact Milltronics or your local distributor.

## Transducer Ringing

If the transducer is mounted too tightly, or if it is mounted so that its side touches something, its resonance characteristics change and this can cause problems.

### Normal Ringdown

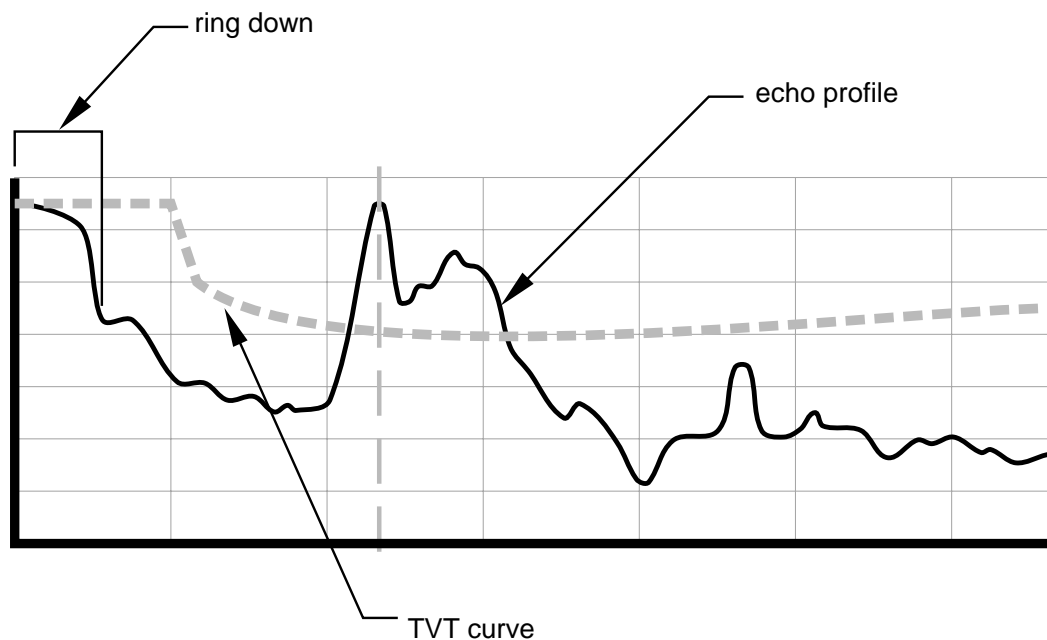

### Poor Ringdown

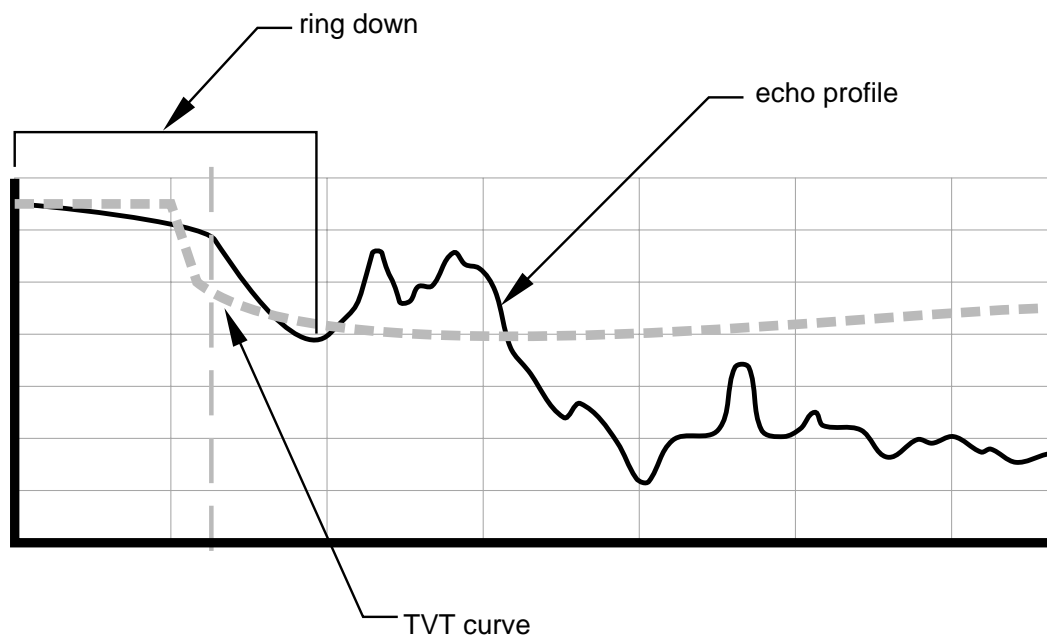

Troubleshooting

Ring down times that extend past the near blanking area can be interpreted by the EnviroRanger as the material level and are characterized by a steady high level being reported.

# Appendix C – Pump Control

---

The EnviroRanger has the pump control strategies to solve nearly any water / wastewater application. This section details these strategies for engineers requiring in-depth knowledge of the system and how it operates.

## Pump Control Options

The various methods of pump control are made up of a combination of two control vectors:

### Pump Duty

The pump duty indicates in what sequence pumps are started.

### Pump Start Method

The start method indicates whether new pumps start and run with any currently running pumps (most common) or whether new pumps start and shut off currently running pumps.

## Pump Availability

The way pumps are affected by interlocks depends on a number of parameters, mostly in the 500 series. They can be local or remote meaning that commands to run can come from the EnviroRanger itself or an external system through one of the communication ports. They can be auto or manual meaning that commands to run can come from EnviroRanger's pump control algorithms or from a manual / local switch.

See Pump Control Source (P520 to P524) on page 138 for information on how pump availability is reported.

## Pump Groups

The EnviroRanger groups pumps that use identical pumping strategies based on the value of P111 (IR) Relay Control Function. Generally, one group of pumps corresponds to one wet well or reservoir.

## Pump by Rate

To trigger pump starts by the rate of change in material level use P121 (G) Pump by Rate found on page 88. New pumps are started, one at a time, until the rate setpoint (P702 (G) Filling Indicator on page 160, or P703 (G) Emptying Indicator on page 160) is reached.

# Discrete Inputs

Some pumps can tell the EnviroRanger through contacts that they are running (confirmation) or experiencing a fault.

Pumps can be removed from the rotation if they are not pumping efficiently or they are reporting a failure. Failures are reported using the discrete interlocks provided on the EnviroRanger.

To configure the EnviroRanger to pull a pump out of the rotation based on the discrete input, follow these steps:

1. Wire the discrete inputs for the pumps to the appropriate terminals on the terminal block (see the EnviroRanger Installation Guide for terminal block information)
2. Configure the Discrete Input Functions (P270 to P275) (see page 111)
3. Configure the Pump Interlock Allocation (P500 to P509) (see page 128)
4. Test the setup (see Testing the Configuration on page 49)

## Pump Failure

When a pump fails it is automatically taken out of service.

To put the pump back into service an operator must go to the location and manually set P510 back to “0” from “1”, or a SCADA system must be in place to reset the pump control bits. See the EnviroRanger Communications Reference for details on the Modbus register to use.

A reset push-button wired to a discrete input and programmed with P509 allows pump faults to be reset.

## Auto / Manual

A pump can be controlled based on an “Auto / Manual” switch connected to a discrete input. The pump is returned to EnviroRanger control as soon as the switch is set back to “auto.”

This ability is also available through communications so that a remote system can control a pump directly.

## Pump Control Algorithms

All of these algorithms can be used to start multiple pumps (assist) or one pump at a time (backup). The EnviroRanger has three main methods of pump control:



**Fixed**

Starts pumps based on individual setpoints and always starts the same pumps in the same sequence.

**Alternate**

Starts pumps based on the duty schedule and always leads with a new pump.

**Service Ratio**

Starts pumps based on user-defined ratio of running time.

**Fixed Duty Assist (P111 = 50)**

*Ties the indexed pump relay directly to the indexed setpoint.*

**Relay Operation (for P118 = 2)**

The relay contact closes at the “on” setpoint and opens at the “off” setpoint. Multiple relay contacts in the pump group can be closed at the same time.

**Relay Table**

The following table shows relay status when each setpoint is reached.

		Relays		
Setpoints	index	1	2	3
	on 3	On	On	On
	on 2	On	On	Off
	on 1	On	Off	Off
	off 0	Off	Off	Off

**Fixed Duty Backup (P111 = 51)**

*Ties the indexed pump relay directly to the indexed setpoint.*

**Relay Operation (for P118 = 2)**

The relay contact closes at the “on” setpoint and opens at the “off” setpoint. When a new relay trips the previously closed relay contact opens to shut down the running pump.

Only one relay contact in the pump group can be closed at any one time.

## Relay Table

The following table shows relay status when each setpoint is reached.

		Relays		
Setpoints	index	1	2	3
	on 3	Off	Off	On
	on 2	Off	On	Off
	on 1	On	Off	Off
	off 0	Off	Off	Off

## Alternate Duty Assist (P111 = 52)

*Alternates the lead pump each time the material level cycles and runs all pumps together.*

## Relay Operation (for P118 = 2)

The setpoints associated with the relays are grouped so that they can be rotated.

Setpoint one does not relate directly to relay one. The pumping algorithm manages the mapping of setpoints to relays.

When pumps are run, they run in parallel.

## Relay Table

When the material level cycles, these are the results:

Cycle 1		Relays		
		1	2	3
Setpoints	on 3	On	On	On
	on 2	On	On	Off
	on 1	On	Off	Off
	off 0	Off	Off	Off
Cycle 2		Relays		
		1	2	3
Setpoints	on 3	On	On	On
	on 2	Off	On	On
	on 1	Off	On	Off
	off 0	Off	Off	Off
Cycle 3		Relays		
		1	2	3
Setpoints	on 3	On	On	On
	on 2	On	Off	On
	on 1	Off	Off	On
	off 0	Off	Off	Off

## Alternate Duty Backup (P111 = 53)

*Alternates the lead pump each time the material level cycles and runs only one pump at a time.*

### Relay Operation (for P118 = 2)

The setpoints associated with the relays are grouped so that they can be rotated.

Setpoint one does not relate directly to relay one. The pumping algorithm manages the mapping of setpoints to relays.

When pumps are run, they can run only one at a time.

### Relay Table

When the material level cycles, these are the results:

Cycle 1		Relays		
		1	2	3
Setpoints	on 3	Off	Off	On
	on 2	Off	On	Off
	on 1	On	Off	Off
	off 0	Off	Off	Off
Cycle 2		Relays		
		1	2	3
Setpoints	on 3	On	Off	Off
	on 2	Off	Off	On
	on 1	Off	On	Off
	off 0	Off	Off	Off
Cycle 3		Relays		
		1	2	3
Setpoints	on 3	Off	On	Off
	on 2	On	Off	Off
	on 1	Off	Off	On
	off 0	Off	Off	Off

## Service Ratio Duty Assist (P111 = 54)

*Selects the lead pump based on number of hours each pump has run and the specified ratios that each pump requires. Multiple pumps can run at one time.*

## Relay Operation (for P118 = 2)

The setpoints associated with the relays are grouped so they can be redistributed based on pump run time ratios. The next pump to start or stop is the one with the required time to actual time ratio.

Over time the number of hours demanded of each pump will conform to the ratios specified. Usually, the ratios are specified in percent values.

To create a grouping of pumps where two pumps make up 50% of the run time and the third pump makes up the other 50% P122 is set to these values:

P122 index	value
1	25
2	25
3	50

## Service Ratio Duty Backup (P111 = 55)

*Selects the lead pump based on number of hours each pump has run and the specified ratios that each pump requires. Only one pump can run at a time.*

This algorithm is the same as Service Ratio Duty Assist except that it will only start one pump at a time.

## First In First Out (FIFO) (P111 = 56)

*Selects the lead pump based on the "Alternate" duty but uses staggered off setpoints and shuts down pumps based on the "first in, first out" rule.*

This algorithm starts pumps in the same way as Alternate Duty Assist but uses staggered "off" setpoints to shut the pumps down. When the first "off" setpoint is reached the FIFO rule shuts down the first pump started. If the pumps started in sequence 2,3,1 then they would be shut down in sequence 2,3,1.

## Pump by Rate (P121)

*Starts pumps until the level is changing at the rate specified in P702 or P703.*

Pumping costs can be less because only the highest "on" setpoint needs to be programmed and this results in a lower difference in head to the next wet well which, in turn, results in less energy being used to pump out the well.

# Other Pump Controls

There are a number of other controls available to modify pump behaviour.

## **Pump Run-on (page 91)**

Extends the run period for a pump based on the number of pump starts. This allows for the wet well to be pumped lower than usual and reduces sludge build-up on the well bottom.

## **Pump Exercising (page 93)**

Runs idle pumps and reduce the chance of seizing.

## **Wall Cling Reduction (page 93)**

Varies the “on” and “off” setpoints to keep a fat ring from forming around the walls of the wet well.

## **Pump Group (page 94)**

Allows for two different Alternate Duty Assist or Alternate Duty Backup pump groups in the same application.

## **Energy Savings (page 95)**

Modifies pump setpoints based on the time of day to minimize head and run time (and subsequent cost) during high cost periods.

## **Overflow (page 99)**

Takes special action (open valve, stop pumps, start all pumps) when a 3Hi alarm (overflow) occurs. This can also be used as a 3Lo alarm (underflow).

## **Flush Device (page 103)**

Operates a flush valve or special flush device based on the number of pump starts, usually to aerate wet well wastewater.



# Appendix D – Discrete inputs

The discrete inputs on the EnviroRanger allow the unit to be more flexible by interlocking control functions with external conditions in the wet well.

To configure a discrete input on the EnviroRanger, follow these steps.

## Wire the Discrete Input

The discrete input contacts are either normally-open or normally-closed when the system state is normal. The normal state refers to standard operation with the EnviroRanger sensing the material level and controlling the pumps.

**Example:**

The normal state for a pump is “operational” and the contacts on the discrete input are wired as normally-open.

See the EnviroRanger Installation Guide (PL-557) for complete details on wiring the discrete inputs.

## Program the Discrete Input Logic

The P270 series of parameters allows for control over the discrete input.

If the DI is...	Set P270 to...
Normally Open	P270 = 2
Normally Closed	P270 = 3

The current value of the discrete input is reported in P275:

P275 is...	The EnviroRanger is in...
0	Normal State
1	Exception State

**Note:**

For P500 (IR) Pump Auto Allocation 1 is the normal state (pump in auto mode) and 0 is the exception state (pump in manual mode) which is reversed from the other pump interlocks.

**Example:**

The pump interlock is programmed to return “0” for the normal state and “1” for the fault state.

# Program the Interlock Logic

The interlock can take one of three forms, detailed below.

## Overflow or Underflow Event

Used to detect an unusual flow event such as a storm overflowing a wet well.

### Determine the Source

Set P160 (G) Overflow / Underflow Level Source as described on page 99.

### Determine the Action

Set P165 (IR) Overflow / Underflow Relay Action as described on page 102.

Check the status of the unit via a SCADA system or by viewing P169. See the EnviroRanger Communications Reference (PL-558) for details on connecting to a SCADA system.

## Power Failure

Used to keep the EnviroRanger from running the pumps when a power failure occurs. If the EnviroRanger attempts to run the pumps and any efficiency, run status, or fault interlocks are programmed then it can erroneously flag all of the pumps as not available and require a reset before they become available once again.

To avoid this P502 (G) Power Failure Allocation (page 130) should be used.

This only applies if the EnviroRanger is on a separate power supply from the pumps so that it remains operational even when the pump power supply fails.

## Pump Control Source

Used to determine from where a pump is controlled. This is generally from a manual switch, the EnviroRanger's pump control algorithms, or from a remote SCADA system.

### Manual Override Switch

- Use P500 (IR) Pump Auto Allocation (page 128) to define how the switch works.
- Use the Pump Control Source (P520 to P524) parameters found on page 138 to determine a pump's current state.

### Remote Control

- Use P501 (IR) Pump Remote Control Allocation (page 129) to define how the switch works.
- Use the Pump Control Source (P520 to P524) parameters found on page 138 to determine a pump's current state.



## Pump Status

Used to confirm that a pump is operating correctly and to remove it from the duty schedule if it is not.

The interlock events that can remove a pump from the duty schedule are<sup>7</sup>:

### Failure to Start

Use P503 (IR) Pump Run Status Allocation and P504 (IR) Pump Run Status Time Delay as detailed on page 131. P503 determines the discrete input to watch and P504 sets a timer to allow the pump time to start.

Use P510 (IR) Pump Failed Status (page 134) to determine if a pump has failed and P511 (V)(IR) Pump Run Fault Status to determine if it was due to a failure to start.

### Fault

Use P505 (IR) Pump Fault “A” Allocation or P506 (IR) Pump Fault “B” Allocation as detailed on page 132. The EnviroRanger can handle up to two fault conditions per pump.

Use P510 (IR) Pump Failed Status (page 134) to determine if a pump has failed and either...

- P513 (V)(IR) Pump Fault “A” Status, or
- P514 (V)(IR) Pump Fault “B” Status

...to determine if it was due to a pump fault.

#### Example:

The pump has P513 configured to detect a fault. This parameter watches P275 for a “1” state and changes itself and P510 if a “1” is detected.

The status parameters (Pump Fault Status (P510 to P515) on page 134) are latched and must be reset before the pump(s) will resume operation.

#### Example:

Once a fault state is detected then P509[0] must be reset to “0” before the pump will be returned to the duty schedule.

## Pump Reset

To make resetting the pumps easier, attach a push-button to a discrete input and program it with P509 (IR) Pump Reset Allocation (page 133). This allows an operator to reset the pumps without using the hand programmer or Dolphin Plus.

<sup>7</sup> A pump efficiency event can also remove a pump from the duty schedule. See Pump Efficiency (P180 to P186) on page 105 for details.

## Test the Interlock

Once wired and programmed test the interlocks to verify operation.

Use P270 (IDI) Discrete Input Function (page 111) to force the input “on” or “off” and verify that the unit responds as expected.

Testing the interlocks is part of a complete system test as described in Testing the Configuration on page 49.

# Index

0 index .....	16	application examples .....	23
0/4 mA input level .....	108	application testing .....	52
20 mA input level .....	109	applications	
about the enviro ranger .....	9	alarms .....	23
about this manual .....	7	OCM .....	32
advanced echo processing .....	180	preset .....	72
advanced shot adjustment .....	188	pump control .....	26
advanced TVT adjustment .....	185	simple level .....	23
aeration .....	83	testing .....	49
alarm		auto / manual .....	216
designation .....	76	auto record “off” setpoint .....	125
emptying .....	77	auto record “on” setpoint .....	125
emptying rate .....	25	auto record enable .....	123
filling .....	77	auto record filling / emptying .....	125
filling rate .....	25	auto record interval .....	124
high high .....	24	auto record LOE time .....	126
in bounds .....	77	auto record on / off setpoints .....	125
level .....	76	auto record transducer .....	123
LOE .....	24	auto zero head .....	147
loss of echo (loe) .....	78	autobaud .....	173
low .....	24	auxiliary reading .....	12, 166
out of bounds .....	24, 77	auxiliary reading key .....	166
rate of change .....	77	availability	
temperature .....	78	pumps .....	138
transducer cable fault .....	78	average	
alarm control .....	74	display .....	13
alarms .....	23, 76	backlight .....	167
clock failure .....	78	backup duty	
power failure .....	78	parameter (P111) .....	81
pump efficiency .....	78	baud rate .....	171
pump failure .....	78	blanking	
time of day .....	78	parameter .....	176
algorithm		troubleshooting .....	212
echo .....	183	with span .....	60
pump control .....	74	breakpoint flowrates .....	146
alternate .....	217	breakpoint levels .....	64
alternate duty		breakpoints	
parameter (P111) .....	81	flow .....	145
alternate duty assist .....	218	head .....	145
alternate duty backup .....	26, 29, 219	volume .....	64
analog input .....	See mA input	BS-3680 / ISO 1438/1 .....	140
application		BS-3680 / ISO 4359 .....	140
documentation .....	52	bus error .....	175

bus error count .....	175	data logging parameters.....	115
calibration .....	154	date.....	12, 60
changing parameters		date format .....	168
dolphin plus .....	17	date of manufacture.....	127
hand programmer.....	18	dead band.....	86
characterization		dead zone.....	See blanking
flow .....	145	decimal position.....	66
volume.....	64	default values .....	19
Cipolletti weir .....	141	design the control scheme.....	21
clock failure.....	78	differential	
close gate .....	45	display .....	13
common problems .....	205	digital inputs.....	See discrete inputs
communication .....	83	digital outputs .....	See relay parameters
communications.....	170	dimensions	
baud rate .....	171	OCM.....	142
data bits.....	172	PMD .....	142
flow control .....	172	discrete input	
front port test .....	192	pump interlock.....	31, 128
inactivity timeout.....	173	discrete input 0Hz scaling .....	112
index location .....	174	discrete input filter time constant.....	113
key up delay .....	172	discrete input function.....	111
modem available .....	173	discrete input functions.....	111
network address .....	170	discrete input upper frequency .....	113
parity.....	171	discrete inputs .....	216, 223
protocol.....	170	indexing .....	16
rear port test .....	191	overview .....	223
register map .....	174	testing.....	51
SmartLinx reserved .....	169	display	
SmartLinx testing.....	175	any parameter .....	12
stop bits .....	172	auxiliary reading .....	12
Communications Reference .....	7	date .....	12
confidence threshold .....	178	distance .....	12
control.....	82	echo confidence .....	12
aeration .....	83	failsafe time left .....	12
communication .....	83	flow .....	12
flush valve .....	83	head (OCM).....	12
gate .....	83	panel mount.....	10
other devices .....	82	parameter (P903) .....	190
overflow .....	83	pump hours .....	12
penstock.....	83	pump starts.....	12
pumps.....	80	rack mount.....	10
storm .....	83	rate of change .....	12
time.....	82	readings.....	12
control function .....	74	temperature .....	12
convert reading.....	66	time.....	12
data bits .....	172	totalizer.....	12

wall mount .....	10	failsafe time left.....	12
display and reading parameters .....	66	FIFO	
display delay.....	167	parameter (P111) .....	82
display parameters .....	166	filling indicator.....	160
displays.....	20	filling rate alarm .....	25
distance .....	12	finding information .....	8
distance calculation .....	198	first in first out (FIFO).....	220
distance measurement .....	194, 195	fixed .....	217
document the installation.....	22	fixed duty	
documentation .....	52	parameter (P111) .....	81
dolphin plus .....	17	fixed duty assist.....	217
dolphin plus display .....	198	fixed duty backup.....	217
echo		fixed reading.....	211
LOE timer .....	69	flashing LOE display.....	209
echo confidence		flow .....	12
parameter (P805) .....	178	flow calculation .....	201
run mode .....	12	flow control .....	172
echo lock .....	162	flow exponent .....	141
echo lock sampling.....	163	flow max .....	120
echo lock window .....	163	flow measurement.....	194
echo marker trigger .....	184	flow min .....	120
echo processing .....	197	flow records parameters.....	120
advanced.....	180	flow sample mantissa .....	151
basic.....	176	flow sampler .....	80
shot adjustment.....	188	flow sampler exponent.....	152
TVT adjustment.....	185	flow setpoint "on" .....	100
echo processing .....	176	flow totals.....	79
echo profile example .....	180	flowrate decimal.....	144
echo strength.....	179	flowrate units .....	145
echo time.....	181	flume dimension "D" .....	142
empty.....	59	flumes	
emptying indicator .....	160	cut throat .....	42
emptying rate alarm.....	25	H flume.....	38
energy saving .....	95	Leopold Lagco.....	41
energy savings example.....	97	Palmer Bowlus .....	37
engineering units .....	59	Parshall .....	40, 43
entering values .....	18	rectangular .....	36
error codes .....	20	universal trapezoidal .....	43
exponential .....	140	flush control relay .....	103
factory values .....	19	flush cycles.....	103
failsafe		flush duration.....	104
per relay .....	90	flush interval .....	104
timer .....	69	flush systems.....	103
failsafe level advance .....	71	flush valve.....	83
failsafe material level.....	70	frequency input.....	111
failsafe parameters .....	69	frequency inputs	

scaling .....	112	LCD total low .....	121
function		LCD totalized multiplier.....	150
general .....	82	LCD totalizer.....	150
other devices .....	82	LCD totalizer parameters.....	121
pumps.....	80	Leopold Lagco .....	141
fuzz filter .....	162	Leopold Lagco flume .....	41
gate.....	83	level alarm .....	76
gate control.....	44	level alarm designation.....	77
close .....	45	level change rate .....	159
open .....	45	level source .....	74
global reset.....	133	level system sync .....	164
H flume .....	38, 140	library.....	7
hand programmer .....	11	books.....	7
hanging up.....	173	lock	
hardware error .....	175	description .....	20
head breakpoints .....	145	parameter .....	56
head measurement.....	12, 194	LOE alarm .....	24
head vs. flowrate breakpoints.....	146	long shot frequency .....	188
high high alarm .....	24	long shot number.....	188
hysteresis .....	See dead band	long shot width.....	189
in bounds .....	77	loss of echo .....	78
incorrect reading.....	213	during testing.....	12
independent failsafe relays.....	90	recording .....	126
index 0 .....	16	timer .....	69
indexing		low alarm .....	24
parameters .....	16	low efficiency action.....	107
points.....	16	low efficiency counter .....	107
inflow / discharge adjust .....	148	low efficiency counter setpoint.....	106
infrared interface test.....	191	low flow cutoff .....	146
input filter time constant.....	109	mA input .....	108, 192
install the enviro ranger .....	21	20 mA calibration.....	110
installation		20 mA trim .....	110
testing.....	49	4 mA calibration.....	110
Installation Guide.....	7	calibration .....	110
installation records.....	127	raw value .....	110
interlock		trim .....	110
pump .....	31, 128	mA input range .....	108
interlocks .....	223	mA input trim .....	110
introduction .....	7	maintaining operation .....	52
key up delay .....	172	master reset.....	196
keypad .....	191	material.....	57
program mode .....	11	material measurement.....	193
run mode .....	11	max empty rate.....	159
LCD level alarm designation.....	77	max fill rate .....	159
LCD total decimal .....	150	max volume .....	63
LCD total high.....	121	maximum flow.....	143

maximum frequency .....	113	off setpoint .....	27, 30
maximum head .....	142	offset calibration .....	154
maximum process speed		offset correction .....	155
parameter .....	58	offset reading.....	67
technical reference .....	203	on setpoints .....	27, 30
measurement.....	193	open channel monitoring	
measurement difficulties.....	209	applications .....	32
measurement units .....	59	parameters .....	140
measurement verification parameters		open gate.....	45
.....	162	operation.....	57
memory.....	190	optional parameters.....	28
Modbus		other codes.....	20
index location .....	174	other manuals.....	7
mode		other pump controls.....	221
program .....	9	out of bounds.....	77
run .....	9	out of bounds alarm.....	24
modem		overflow .....	83, 99
available .....	173	overflow (CSO) records .....	119
inactivity timeout.....	173	overflow action.....	102
modes of operation.....	9	overflow condition.....	102
narrow echo filter .....	184	overflow delay time.....	101
near blanking .....	176	overflow event dates.....	119
troubleshooting.....	212	overflow event duration .....	119
with span .....	60	overflow event times.....	119
network address .....	170	overflow level source .....	99
noise .....	179	overflow setpoint “off” .....	100
noise problems .....	206	overflow setpoint “on” .....	100
noise sources .....	208	overflow max duration .....	101
OCM .....	32	P000 (G) Lock .....	56
common parameters .....	33	P001 (G) Operation .....	57
cut throat .....	42	P002 (G) Material .....	57
direct support.....	35	P003 (IT) Maximum Process Speed... 58	
flow characterization chart.....	42	P004 (G) Transducer.....	58
flow exponent support .....	39	P005 (G) Units.....	59
H flume .....	38	P006 (IT) Empty .....	59
Leopold Lagco flume .....	41	P007 (IT) Span .....	60
Palmer Bowlus flume.....	37	P008 (G) Date .....	60
Parshall flume.....	40	P009 (G) Time .....	61
rectangular flume.....	36	P050 (G) Tank Shape.....	62
testing flow values .....	50	P051 (G) Max Volume.....	63
universal .....	42	P052 (G) Tank Dimension .....	64
universal Parshall flume .....	43	P053 (G) Tank Dimension ‘L’ .....	64
universal trapezoidal flume.....	43	P054 (IB) Breakpoint Levels.....	64
V notch weir.....	35	P055 (IB) Volume Breakpoints .....	65
weirs .....	39	P060 (IT) Decimal Position.....	66
OCM parameters .....	140	P061 (IT) Convert Reading.....	66

P062 (IT) Offset Reading.....	67	P182 (IR) Pump Measured Capacity	106
P070 (G) Failsafe Timer .....	69	P183 (IR) Pump Rated Capacity .....	106
P071 (IT) Failsafe Material Level.....	70	P184 (IR) Pump Low Efficiency Counter Setpoint.....	106
P072 (IT) Failsafe Level Advance .....	71	P185 (IR) Pump Low Efficiency Action .....	107
P100 (G) Preset Applications .....	72	P186 (V) Pump Low Efficiency Counter .....	107
P110 (IR) Level Source .....	74	P250 (G) mA Input Range .....	108
P111 (ir) Relay Control Function .....	74	P251 (G) 0/4 mA Input Level .....	108
P112 (IR) Relay “on” Setpoint .....	84	P252 (G) 20 mA Input Level .....	109
P113 (IR) Relay “off” Setpoint .....	84	P253 (G) Input Filter Time Constant.	109
P114 (IR) Relay “duration” Setpoint ...	85	P254 (V) Scaled mA Input Value.....	109
P115 (IR) Relay “interval” Setpoint.....	85	P260 (V) mA Raw Input.....	110
P116 (IR) Dead Band .....	86	P261 (G) 4 mA Trim .....	110
P118 (IR) Relay Output Logic.....	86	P262 (G) 20 mA Trim .....	110
P119 (IR) Relay Logic Test .....	87	P270 (IDI) Discrete Input Function ...	111
P121 (G) Pump by Rate .....	88	P271 (IDI) Discrete Input 0Hz Scaling .....	112
P122 (IR) Pump Service Ratio .....	89	P272 (IDI) Discrete Input Upper Frequency Scaling .....	113
P129 (IR) Relay Failsafe .....	90	P273 (IDI) Discrete Input Upper Frequency .....	113
P130 (G) Pump Run-On Interval .....	91	P274 (IDI) Discrete Input Filter Time Constant.....	113
P131 (G) Pump Run-On Duration .....	91	P275 (V) Scaled Discrete Input Value .....	114
P132 (G) Pump Start Delay.....	92	P300 (V) Temperature, Transducer Max .....	115
P133 (G) Pump Power Resumption Delay .....	92	P301 (V) Temperature, Transducer Min .....	115
P134 (IR) Pump Exercising .....	93	P302 (V) Temperature, Sensor Max.	116
P136 (G) Wall Cling Reduction.....	93	P303 (V) Temperature, Sensor Min..	116
P137 (IR) Pump Group .....	94	P304 (V) Reading Max .....	117
P140 (G) Energy Saving.....	95	P305 (V) Reading Min .....	117
P141 (IB) Peak Start Time.....	95	P310 (IR) Pump Hours .....	118
P142 (IB) Peak End Time.....	95	P311 (IR) Pump Starts .....	118
P143 (G) Peak Lead Time.....	96	P312 (IR) Pump Run Ons.....	118
P144 (IR) Peak “on” Setpoint .....	96	P313 (V) Overflow Event Dates.....	119
P145 (IR) Peak “off” Setpoint .....	97	P314 (V) Overflow Event Times .....	119
P146 (IR) Time of Day Setpoint.....	98	P315 (V) Overflow Event Duration ...	119
P160 (G) Overflow Level Source.....	99	P320 (V) Flow Max.....	120
P161 (G) Overflow Setpoint “on” .....	100	P321 (V) Flow Min .....	120
P162 (G) Overflow Setpoint “off” .....	100	P322 (G) LCD Total Low .....	121
P163 (G) Overflow Time Delay.....	101	P323 (G) LCD Total High .....	121
P164 (G) Overflow Maximum Duration .....	101	P330 (IE) Profile Record.....	122
P165 (IR) Overflow Relay Action.....	102	P331 (G) Auto Record Enable.....	123
P169 (V) Overflow Condition .....	102	P332 (G) Auto Record Transducer...	123
P170 (G) Flush Control Relay .....	103		
P171 (G) Flush Interval .....	104		
P172 (IR) Flush Cycles.....	103		
P173 (G) Flush Duration.....	104		
P180 (IR) Pump Capacity Reference	105		
P181 (G) Pump Capacity Time.....	105		



P333 (G) Auto Record Interval .....	124	P633 (G) LCD Totalized Decimal .....	150
P334 (G) Auto Record “on” Setpoint	125	P640 (G) Remote Totalized Multiplier	
P335 (G) Auto Record “off” Setpoint	125	.....	151
P336 (G) Auto Record Filling / Emptying		P641 (G) Flow Sample Mantissa.....	151
.....	125	P642 (G) Flow Sampler Exponent....	152
P337 (G) Auto Record LOE Time.....	126	P645 (G) Relay Duration .....	152
P341 (V) Run Time.....	127	P650 (G) Offset Calibration .....	154
P342 (V) Start Ups .....	127	P651 (G) Sound Velocity Calibration	154
P500 (IR) Pump Local Auto Allocation		P652 (G) Offset Correction.....	155
.....	128	P653 (G) Velocity .....	155
P501 (IR) Remote Control Allocation	129	P654 (G) Velocity at 20°C .....	156
P502 (G) Power Failure Allocation ...	130	P660 (IT) Temp Source.....	157
P502 (IR) Pump Run Allocation.....	131	P661 (IT) Temp Fixed.....	157
P504 (IR) Pump Run Status Time Delay		P663 (IT) Temperature Transducer	
.....	131	Allocation .....	157
P505 (IR) Pump Fault “A” Allocation	132	P664 (V) Temperature.....	158
P506 (IR) Pump Fault “B” Allocation	132	P700 (G) Max Fill Rate .....	159
P509 (IR) Pump Global Reset Allocation		P701 (G) Max Empty Rate .....	159
.....	133	P702 (G) Filling Indicator.....	160
P510 (IR) Pump Failed Status.....	134	P703 (G) Emptying Indicator .....	160
P511 Pump Run Status .....	135	P704 (G) Rate Filter .....	160
P512 Pump Low Efficiency Fault.....	135	P705 (G) Rate Update Time.....	161
P513 Pump Fault “A” Status.....	136	P706 (G) Rate Update Distance.....	161
P514 Pump Fault “B” Status.....	136	P707 (V) Rate Value.....	161
P515 Pump Remote Control Status .	136	P708 (V) Volume Rate Display.....	161
P519 (V) Power Failure Status .....	137	P710 (G) Fuzz Filter .....	162
P520 (V)(IR) Pump Available .....	138	P711 (G) Echo Lock .....	162
P521 (V)(IR) Pump in Local Auto .....	138	P712 (G) Echo Lock Sampling .....	163
P522 (V)(IR) Pump in Local Manual.	138	P713 (G) Echo Lock Window .....	163
P523 (V)(IR) Pump in Remote Auto .	139	P726 (G) Level System Sync .....	164
P524 (IR) Pump in Remote Manual..	139	P727 (G) Scan Delay.....	164
P600 (G) Primary Measuring Device	140	P728 (IT) Shot Delay .....	164
P601 (G) Flow Exponent .....	141	P729 (IT) Scan Time .....	165
P602 (ID) PMD Dimensions .....	142	P730 (G) Auxiliary Reading.....	166
P603 (G) Maximum Head.....	142	P731 (G) Auxiliary Reading Key.....	166
P604 (G) Maximum Flow.....	143	P732 (G) Display Delay .....	167
P605 (G) Zero Head .....	143	P733 (G) Scroll Access .....	167
P606 (G) Time Units.....	144	P735 (G) Backlight .....	167
P607 (G) Flowrate Decimal .....	144	P736 (G) Date Format .....	168
P608 (G) Flowrate Units .....	145	P737 (G) Primary Reading .....	168
P610 (IB) Head Breakpoints.....	145	P739 (G) Time Zone.....	168
P611 (IB) Breakpoint Flowrates.....	146	P770 (IP) Protocol .....	170
P620 (G) Low Flow Cutoff .....	146	P771 (IP) Network Address.....	170
P621 (G) Auto Zero Head.....	147	P772 (IP) Baud Rate .....	171
P622 (G) Inflow / Discharge Adjust ..	148	P773 (IP) Parity .....	171
P623 (G) Pump Total Method.....	148	P774 (IP) Data Bits.....	172
P630 (G) LCD Totalized Multiplier....	150		

P775 (IP) Stop Bits .....	172	P904 (G) Keypad.....	191
P776 (IP) Port Flow Control.....	172	P905 (IT) Transmit Pulse.....	191
P777 (IP) Key Up Delay .....	172	P906 (G) Rear RS-232 Port .....	191
P778 (IP) Modem Available.....	173	P907 (G) Infrared Interface.....	191
P779 (IP) Modem Inactivity Timeout	173	P909 (G) Front RS-232 Port.....	192
P782 (G) Parameter Index Location.	174	P912 (IT) Transducer Temperature..	192
P790 (G) Hardware Error .....	175	P913 (G) Sensor Temperature .....	192
P791 (G) Bus Error.....	175	P914 (G) mA Input.....	192
P792 (G) Bus Error Count .....	175	P920 (IT) Reading Measurement .....	193
P800 (G) Near Blanking .....	176	P921 (IT) Material Measurement.....	193
P801 (G) Range Extension.....	176	P922 (IT) Space Measurement .....	194
P802 (G) Submergence Transducer	177	P923 (IT) Distance Measurement.....	194
P803 (G) Shot / Pulse Mode.....	177	P924 (G) Volume Measurement.....	194
P804 (G) Confidence Threshold.....	178	P925 (G) Flow Measurement .....	194
P805 (V) Echo Confidence .....	178	P926 (G) Head Measurement .....	194
P806 (V)(IT) Echo Strength.....	179	P927 (IT) Distance Measurement.....	195
P807 (V)(IT) Noise.....	179	P999 (G) Master Reset.....	196
P810 (IT) Scope Displays.....	180	Palmer Bowlus flume.....	37, 140
P816 (V)(IT) Echo Time.....	181	parameter	
P817 (V) Profile Pointer Time.....	182	scrolling .....	18
P818 (V) Profile Pointer Distance....	182	parameter index.....	17
P819 (V) Profile Pointer Amplitude...	182	parameter indexing.....	16
P820 (G) Algorithm .....	183	parameter reference .....	55
P821 (G) Spike Filter .....	183	how to read.....	55
P822 (G) Narrow Echo Filter .....	184	parameter reset .....	19
P823 (G) Reform Echo .....	184	parameters	
P825 (G) Echo Marker Trigger .....	184	alarms.....	76
P830 (G) TVT Type .....	185	changing.....	18
P831 (G) TVT Shaper.....	185	communications .....	170
P832 (IB) TVT Shaper Adjust.....	185	control.....	82
P833 (G) TVT Start Min.....	186	flow totals .....	79
P834 (G) TVT Start Duration .....	186	global.....	19
P835 (G) TVT Slope Min .....	187	indexed.....	19
P840 (G) Short Shot Number .....	188	pumps.....	80
P841 (G) Long Shot Number.....	188	special .....	19
P842 (G) Short Shot Frequency .....	188	types.....	55
P843 (G) Long Shot Frequency.....	188	view only.....	19
P844 (G) Short Shot Width.....	189	parity.....	171
P845 (G) Long Shot Width .....	189	Parshall flume.....	141
P850 (G) Short Shot Bias .....	189	peak "off" setpoint.....	97
P851 (G) Short Shot Floor.....	189	peak "on" setpoint.....	96
P852 (G) Short Shot Range .....	189	peak end time .....	95
P900 (V) Software Revision # .....	190	peak lead time .....	96
P901 (V) Memory .....	190	peak start time .....	95
P902 (V) Watchdog .....	190	penstock .....	83
P903 (V) Display.....	190	penstock control .....	44

percent.....	18	optional.....	28
performance test results .....	52	pump down.....	26
planning considerations.....	21	pump up .....	29
PMD dimensions .....	142	reservoir .....	29
points		service ratio.....	27
indexing.....	16	totalizing volume .....	28
power failure		wet well.....	26
alarm .....	78	pump availability.....	138
power failure allocation.....	130	overview .....	215
power failure status .....	137	pump available .....	138
power resumption delay .....	92	pump by rate.....	88, 220
preset application chart .....	73	overview .....	215
preset applications.....	72	pump capacity reference .....	105
primary measuring device .....	140	pump capacity time.....	105
primary reading.....	168	pump control	
profile pointer.....	182	alternate duty.....	81
profile pointer amplitude .....	182	applications .....	26
profile pointer distance .....	182	backup duty.....	81
profile pointer time .....	182	FIFO .....	82
profile record.....	122	fixed duty .....	81
profile records parameters.....	122	overview .....	215
program button .....	15	parameter (P111) .....	74
program mode .....	9	service ratio .....	81
starting.....	16	pump control algorithms .....	216
program the enviro ranger .....	21	pump control modifiers .....	91
programmer interface test .....	191	pump control options .....	215
programming		pump control source.....	138
by hand.....	11	pump down .....	26
index.....	17	pump duty.....	215
panel mount.....	15	pump efficiency.....	105
parameter index .....	17	alarm .....	78
rack and panel mount.....	15	pump energy cost reduction .....	95
rack mount.....	15	pump exercising .....	93
programming guide.....	15	pump failed status .....	134
programming reference .....	55	pump failure.....	216
Programming Reference .....	7	alarm .....	78
protocol.....	170	pump fault "A" allocation.....	132
pulse counter input .....	111	pump fault "A" status .....	136
pump		pump fault "B" allocation.....	132
alternate duty backup .....	26, 29	pump fault "B" status .....	136
by rate .....	27	pump global reset allocation.....	133
discrete input .....	31	pump group	
fault.....	31	overview .....	215
interlock.....	31	parameter (P137) .....	94
off setpoint.....	27, 30	pump hours.....	12, 118
on setpoints .....	27, 30	pump in local auto .....	138

pump in local manual.....	138	recording profiles .....	123
pump in remote auto.....	139	rectangular flume.....	36
pump in remote manual.....	139	reform echo .....	184
pump interlock .....	31	relay	
pump interlock allocation .....	128	aeration .....	83
pump interlock status.....	134	communication .....	83
pump local auto .....	128	flush valve .....	83
pump low efficiency fault .....	135	logic.....	86
pump measured capacity .....	106	logic test.....	87
pump rated capacity .....	106	negative logic .....	87
pump records parameters .....	118	overflow .....	83
pump remote control status .....	136	penstock.....	83
pump run allocation .....	131	positive logic.....	87
pump run ons.....	118	storm .....	83
pump run status.....	135	time.....	82
pump run status time delay .....	131	relay “duration” setpoint.....	85
pump run time ratio.....	89	relay “interval” setpoint .....	85
pump run-on duration .....	91	relay “off” setpoint.....	84
pump run-on interval.....	91	relay “on” setpoint.....	84
pump setpoint modifiers .....	88	relay control function .....	74
pump start method.....	215	relay duration.....	152
pump starts.....	12, 118	relay failsafe .....	90
pump status .....	134	relay output logic .....	86
pump strategies .....	215	relay parameters.....	72
pump total method.....	148	relays	
pump up.....	29	flow sampler .....	80
pumped volume totalizer parameters	148	indexing .....	16
pumps.....	80	totalizer.....	79
pumps by rate.....	27	remote control allocation .....	129
quick start .....	57	remote total factor.....	151
rake control.....	46	reset	
range calibration parameters.....	154	parameters .....	19
range extension .....	176	review the application .....	21
rate .....	159	run mode .....	9
rate filter.....	160	readings.....	12
rate of change.....	12, 77	run time.....	127
rate pump .....	88	saving parameter values .....	52
rate update distance .....	161	scaled discrete input value .....	114
rate update time.....	161	scaled mA input value .....	109
rate value .....	161	scaling frequency inputs .....	112
reading max.....	117	scan delay .....	164
reading measurement.....	193	scan time .....	165
reading min.....	117	scanning	
readings in run mode.....	12	technical reference.....	199
record readings parameters .....	117	transducer .....	164
record temperatures .....	115	scope displays	

parameter (P810) .....	180	start ups.....	127
technical reference .....	198	starting program mode .....	16
screen cleaner control .....	46	status	
scroll access .....	167	pump .....	134
scrolling display .....	13	stop bits .....	172
scrolling parameters .....	18	storm.....	83
scum line .....	See wall cling	submergence transducer.....	177
security .....	20	suppressed rectangular weir .....	141
sensor temperature .....	192	synchronization.....	164
service ratio		tank shape .....	62
applications .....	27	tank dimension 'A' .....	64
overview .....	217	tank dimension 'L' .....	64
parameter (P111) .....	81	technical reference .....	197
service ratio duty assist .....	219	temp fixed.....	157
service ratio duty backup.....	220	temp source.....	157
setpoint		temperature	
duration .....	85	alarm .....	78
interval.....	85	parameter (P664) .....	158
off .....	84	run mode .....	12
on .....	84	sensor max.....	116
short shot bias .....	189	sensor min.....	116
short shot floor.....	189	transducer max.....	115
short shot frequency .....	188	transducer min.....	115
short shot number.....	188	temperature compensation parameters	
short shot range.....	189	.....	157
short shot width .....	189	temperature transducer allocation....	157
shot / pulse mode .....	177	test parameters.....	190
shot delay .....	164	test the installation.....	22
simulation .....	See also testing	testing	
full cycle.....	50	application .....	52
OCM flow characterization .....	50	discrete inputs .....	51
parameter (P000) .....	56	full cycle.....	50
parameters (P920 to P926) .....	193	I/O.....	51
single measurement .....	49	relays.....	51
volume characterization .....	50	simulation .....	49
single measurement .....	49	single measurement .....	49
SmartLinx hardware testing.....	175	testing the configuration .....	49
SmartLinx reserved .....	169	time	
software revision #.....	190	parameter (P009) .....	61
sound velocity.....	199	relay control.....	82
sound velocity calibration .....	154	run mode .....	12
space measurement .....	194	time of day alarm .....	78
span.....	60	time of day setpoint .....	98
special parameters .....	19	time units .....	144
spike filter .....	183	time variance threshold .....	See TVT
start delay .....	92	time zone .....	168

totalized OCM.....	33	units .....	59
totalized volume		units or percent.....	18
OCM .....	35	upper frequency.....	113
totalizer		using this manual.....	8
flow sample mantissa .....	151	V notch weir.....	35, 141
flow sampler exponent .....	152	values	
high digits .....	121	entering .....	18
LCD total decimal .....	150	velocity.....	155
low digits.....	121	velocity at 20°C.....	156
parameter (P111) .....	79	Venturi flume .....	141
parameters .....	150	volume breakpoints .....	65
pumped volume.....	148	volume calculation.....	200
relay duration.....	152	volume characterization	
remote total factor .....	151	testing.....	50
run mode .....	12	volume measurement.....	194
totalizing pumped volume.....	28	volume parameters.....	62
transducer.....	58, 74	volume rate display.....	161
transducer cable fault .....	78	wall cling reduction .....	93
transducer scanning .....	164	wastewater .....	7
transducer temperature .....	192	watchdog .....	190
transducers		water.....	7
indexing.....	16	weirs .....	39
transmit pulse		V notch .....	35
parameter (P905) .....	191	wet well.....	26
technical reference .....	197	wiring	
troubleshooting.....	205	testing.....	51
TVT shaper.....	185	wiring problems .....	208
TVT shaper adjust .....	185	wrong reading.....	213
TVT slope min .....	187	Y2K compliance.....	61
TVT start duration.....	186	year 2000 compliance .....	61
TVT start min .....	186	zero head.....	143
TVT type .....	185	zero index.....	16





#### **CANADA**

1954 Technology Dr., P.O. Box 4225,  
Peterborough, Ontario, Canada K9J 7B1  
Tel.: (705) 745-2431 Fax: (705) 741-0466

#### **AUSTRALIA**

182 Normanby Rd., Box 339, South Melbourne, Australia  
Tel.: +011-613-9695-2400 Fax: +011-613-9695-2450

#### **BELGIUM**

August van de Wielelei 97, 2100 Deurne, Antwerp, Belgium  
Tel.: +32(0)3326 45 54 Fax: +32(0)3326 05 25

#### **ENGLAND**

Century House, Bridgwater Road, Worcester, England WR4 9ZQ  
Tel: +44 1905 450500 Fax: +44 1905 450501

#### **FRANCE**

Parc de la Sainte Victoire, Bât. 5, 13590, Meyreuil, France  
Tel.: +33 4 42 65 69 00 Fax: +33 4 42 58 63 95

#### **GERMANY**

Werftstrasse 47, D-40549, Dusseldorf, Germany  
Tel: +00 49 211 562 3925 Fax: +00 49 211 562 6030

#### **HONG KONG**

1 Hoi Wan Street, Suite 602, Quarry Bay, Hong Kong  
Tel.: +011 852-2856-3166 Fax: +011 852-2856-2962

#### **MEXICO**

Amores No. 1155, Col. Del Valle, 03100, Mexico D.F.,  
Mexico  
Tel.: +52 5 575-27-28 Fax: +52 5 575-26-86

#### **THE NETHERLANDS**

Nikkelstraat 10, NL-4823 AB Breda, The Netherlands  
Tel.: +31(0)76 542 7 542 Fax: +31(0)76 542 8 542

#### **THE UNITED STATES**

709 Stadium Drive, Arlington, Texas U.S.A. 76011  
Tel.: (817) 277-3543 Fax: (817) 277-3894

A joint venture in **Singapore**, a sales office in **Brazil** and  
distributors in 56 countries.



Visit our web site at:  
[www.milltronics.com](http://www.milltronics.com)