

SCANNER/ANNUNCIATOR

Model PD118 MINIMUX®

Microprocessor-based 8 Channel Scanner
with Built-in Annunciator

Instruction Manual

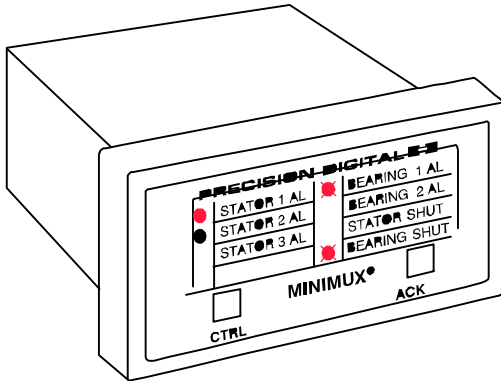

- ✦ 8 Inputs Per Unit
- ✦ Unlimited Number of Units Per System
- ✦ Thermocouples, RTDs, Process, AC & DC Inputs
- ✦ Internally or Externally Controlled Scanning
- ✦ Adjustable Dwell Time for Each Channel
- ✦ Independent Alarm Input for Each Channel
- ✦ First-out Alarm Indication
- ✦ Alarms Indicated by LEDs, Built-in Horn, and Relay
- ✦ Stop-On-Alarmed Channel (field select)
- ✦ FREE Custom Printed Message Labels, *at any time*
- ✦ Removable Screw Terminal Connectors

Precision Digital Corporation
Corporate Headquarters
19 Strathmore Rd • Natick MA 01760 USA
www.predig.com



TABLE OF CONTENTS

Description	3	
Ordering Information	4	
Specifications		5-6
Setup & Programming Overview	7	
Power Selection		8
Connections:		
Overview		9
AC Voltage	10	
Signal Inputs & Output	11-13	
Multiple PD118s		14-15
Alarm-in		16
Alarm Relay		17
Channel Select/Channel ID		18
External CTRL and ACK		19
Programming:		
Overview		20
External or Internal Scan		21
Programming Dwell Time		21-22
Alarm Sequences		23
Stop-On-Alarm		23
Operation:		
Overview		24
Internal Scan, Stop Scan, Quick-scroll		24-25
External Scan		25
Multiple Units		26
Alarms		27-30
Typical Applications:		
Scan 4 Thermocouples into a PD750		31-32
Scan 5 RTDs into a PD750 & PLC	33-34	
Scan 16 RTDs into a PLC		35
Scan 4 Tanks into a PD690, PLC & Annunciate on a PD128		36
PDA-CL (4-20 mA Scanning) Installation	37-38	
Message Labels		39
Mounting Dimensions	40	

PRODUCT DESCRIPTION

The Minimax[®] is a microprocessor-based eight channel analog input scanner/multiplexer and annunciator that provides low cost automatic switching for multi-point display and alarm systems. Each Minimax[®] can automatically switch up to eight inputs to another device such as a digital panel meter, controller, or PLC. Multiple units can be connected together to scan an unlimited number of points. Front panel push-buttons allow for easy programming of independent adjustable dwell times as well as rapid channel skipping. External scanning allows an external device such as a PLC or DCS to direct which channel to scan and for how long. The built-in annunciator logic can detect and indicate which input signals are in alarm condition. The built-in horn, alarm relay, and front panel LEDs are sure to catch the operators attention. Signal switching is done with reed relays making the Minimax[®] ideal for switching thermocouples, RTDs, control loops, and AC & DC signals.



WARNING

Hazardous voltages exist within enclosure. Installation and service should be performed only by trained service personnel.



AVERTISSEMENT

Les pièces à l'intérieur du boîtier portent des tensions dangereuses. Seules des personnes qualifiées et bien entraînées devraient entreprendre l'opération et la maintenance.

Notice

The information contained in this document is subject to change without notice. Unauthorized reproduction is prohibited. © 1997 Precision Digital Corporation

ORDERING INFORMATION

MODEL:	DESCRIPTION:
PD118	8 Channel Scanner/Annunciator; 115 or 230 VAC (field select)
PD118-CL	8 Channel Scanner/Annunciator; 115 or 230 VAC (field select) with current loop resistor network installed (for 4-20 mA inputs)
PDA-CL	Current Loop Resistor Network (for 4-20 mA inputs)

Notes:

- All units are shipped from the factory set for 115 VAC power. See Voltage Selection on page 8 to change power to 230 VAC.
- Message labels for the PD118 may be specified at time of order or later. See page 39 for details.
- Removable screw terminal connectors are standard on the PD118.
- There is no special cable required to connect multiple PD118s together.

Ordering Examples

1. A system to automatically scan and display eight type J thermocouples and check each one for alarm condition, powered from 115 VAC:

Model:	Description:	Quantity:
PD118	8 Channel scanner/annunciator	1
PD750-3-14	Universal temperature meter with 2 relay alarm option, 115 VAC	1

2. A system that switches 24 100 ohm platinum RTDs through a single digital panel meter and then into a PLC. The PLC controls the scan sequence on the PD118 and also uses the PD118 to indicate alarm conditions. The 4-20mA output from the digital panel meter provides a convenient way to bring temperature data into the PLC. Power is 230 VAC:

Model:	Description:	Quantity:
PD118	8 Channel scanner/annunciator	3
PD750-4-15	Universal temperature meter with 4-20 mA output option, 230 VAC	1

SPECIFICATIONS

Number of Channels Per Minimux®: 8 double-pole channels per unit

Number of Channels Per System: Unlimited

Signal Switching: DPST reed relays

Contact Resistance: 0.2 ohms maximum

Maximum Input Voltage: 200 V (switched or common mode)

Maximum Current Switched: 0.5 A

Maximum Power Switched: 10W

Dwell Time (Internal-scan): Each channel adjustable from 0.6 to 30 seconds.

Dwell Time (External-scan): Determined by external device such as a PLC or DCS, 1.5 seconds per channel minimum.

Non-volatile Memory: All programming values are stored in non-volatile memory for ten years if power is lost.

Scan Method: Internal or externally controlled (PLC, etc.)

Channel Select/Channel ID: Input Impedance; 10 Kohm pull-up to 5 V.

Each channel on the Minimux® has a Channel Select/Channel ID line which is used to either select or identify a channel on the PD118. For instance, in External Scan Mode, an external device such as a PLC can drive the Channel Select/Channel ID line low for the channel it wants to see, the PD118 will then go to that channel. In Internal Scan Mode, the Channel Select/Channel ID line for the currently scanned channel goes low to provide identification of the current channel to an external device.

Channel Indication: Green LED on front panel; Channel Select/ID line goes low.

Disabling channels: Channels may be disabled during setup with front panel CTRL button.

Scan Stop: The scan may be stopped by pressing and holding the CTRL button for more than 0.5 seconds. The scan may be resumed by pressing and releasing the CTRL button quickly (less than 0.5 seconds).

Alarm Input: Independent alarm input for each channel. Input Impedance; 25 Kohm, typical pull-up to 5V.

Alarm Sequence: Sequence A or Sequence F2A (first out).

Alarm Outputs: Alarm condition indicated by:

- Front panel red LED for each channel.
- Relay, 1 SPDT (form C); rated 2 Amp @ 30 VDC or 2 Amp @ 250 VAC resistive load; 1/14 HP @ 125 / 250 VAC for inductive loads. For failsafe operation, the relay is energized in the non-alarm state. In the case of a power failure, the relay will go to the alarm state, (NC contact is connected to common).
- Built-in Horn, 75 dB.
- Stop-on-alarmed-channel (user select).

Alarm Acknowledgment: Front panel ACK and rear connector terminals.

External CTRL function: The functions of the CTRL button are available at screw terminals at the rear of the instrument.

Message Labels: Free, custom printed, 1 line per message at 14 characters per line. Factory or field printable.

Connections: Removable screw terminal connectors provided:

J1 - Power: 22 to 12 AWG

J2, J4 - Alarm Input, Channel Select/ID: 28 to 16 AWG

J3 - Analog Signal: 22 to 14 AWG

Environmental:

- Operating temperature: -10°C to 65°C

- Storage temperature: -40°C to 85°C

- Relative humidity: 0 to 95% non-condensing

Power: 115 or 230 VAC (field select), $\pm 10\%$, 50/60 Hz, 4VA.

LED Test: All LEDs are tested on power-up.

Enclosure: 1/8 DIN, high impact plastic, UL94V-0.

Front Panel: NEMA 4X, panel gasket provided.

Warranty: 1 year parts and labor.

Extended Warranty: Warranty may be extended an additional 12 months by returning the Product Registration Form within 2 months from date of purchase.

SETUP AND PROGRAMMING OVERVIEW

Programming and installing the PD118 involves three basic steps:

1. Power Selection: (page 8)

- a. Changing to 230 VAC power if needed. 115 VAC is factory default.

2. Connections: (page 9-19)

- a. AC power
- b. Signal inputs and output
- c. Multiple PD118s (if needed)
- d. Alarm-in (if needed)
- e. Alarm relay (if needed)
- f. Channel Select/Channel ID lines (if needed)
- g. External CTRL and ACK (if needed)

3. Programming the PD118 for various functions: (page 20-23)

- a. Internal or external scan
- b. Dwell times if using internal scanning
- c. Sequence A or Sequence F2A alarm operation (if needed)
- d. Stopping-on-alarm or to continue scanning on alarm (if needed)

VOLTAGE SELECTION

WARNING! All units are shipped from the factory set for 115 VAC power. Do not apply 230 VAC without first setting up the PD118 to accept this voltage.

WARNING! Disconnect power prior to performing the following procedures.

The PD118 is field selectable for either 115 VAC or 230 VAC power. Changing the voltage selection involves the removal of the unit from its case and selecting 230V on switch S4 located on the lower circuit board.

Removing The PD118 From Its Case

The PD118's front cover is held in place by 6 latches that snap into notches on the cover. To remove the front cover grasp it firmly on its top and bottom edges and pull it forward. The latch plate remains around the case.

To remove the circuit board from the case, unscrew the 4 front panel retaining screws and remove the screw terminal connectors at the rear of the unit. Push the boards through the case by applying pressure to the circuit boards at the rear of the unit. Do not apply pressure to the vertical LED board at the front of the unit.

Changing Voltage Selection

Once the unit is removed, switch S4 can be accessed from the rear right side. The switch is a large black component with a red slide switch on the top. Push the switch toward the rear (toward screw terminals) to set the unit for 230 VAC (a screwdriver may aid in this step).

To avoid electric shock, re-install the circuit boards in the case prior to applying power. Install washers and retaining screws in 4 corners of the PD118 and install the front cover.

All programming can be performed with the circuit boards installed in the case.

Voltage Labeling

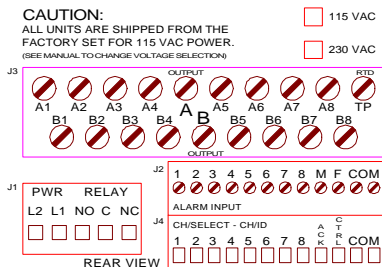

The label on top of the PD118 contains a place for the user to indicate if the unit is to be powered from 115 or 230 VAC.

CONNECTIONS OVERVIEW

All connections are made to removable screw terminal connectors which are supplied with each PD118.

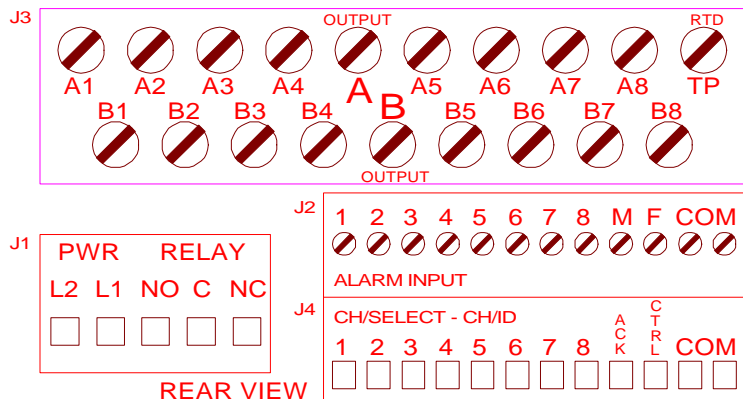

Connector:

J1	Power input and Alarm relay
J2	Alarm-In, Master-Follower
J3	Signal Inputs and Output
J4	Channel Select/Channel ID with External ACK & CTRL

Wire Size:

J1	22 to 12 AWG
J2	28 to 16 AWG
J3	22 to 14 AWG
J4	18 to 16 AWG

Access to screw terminals J2 and J4 are made by first removing terminal J3. To remove terminal J3 grasp it on the left and right edges and pull it away from the unit.

Connector J2 can be removed by pulling it straight up and J4 can be removed by pulling it away from the unit.

Install screw terminal J2 first followed by J4 and J1. Terminal J3 should be installed last.

POWER CONNECTIONS

WARNING! Refer to VOLTAGE SELECTION above to make sure meter is setup to accept proper voltage before applying power.

WARNING! Disconnect power to the PD118 while making any connections.

WARNING! Connecting 230 VAC with 115 VAC selected will result in damage to the instrument as well as endanger personnel.

WARNING! Do not connect Power or Earth Ground to any unused or COM terminals.

Connect line power (115 VAC or 230 VAC) to terminal L2 and L1 on screw terminal J1 located on the rear of the instrument.

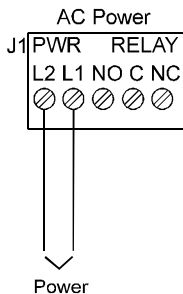

Notice:

Primary voltages must not be accessible to the user.
Must be installed in accordance to the applicable standards.
Keep primary wires separated from signal cables.

SIGNAL CONNECTIONS

Signal input and output connections for the Minimux[®] are made to a 19 position removable screw terminal connector (J3) supplied with each unit.

The following table gives the input and output terminal assignments:

SCREW TERMINAL			
CHANNEL:	+ Line:	- Line:	RTD Common:
3-wire RTD tie point			RTD-TP
Input 1	A1	B1	
Input 2	A2	B2	
Input 3	A3	B3	
Input 4	A4	B4	
Input 5	A5	B5	
Input 6	A6	B6	
Input 7	A7	B7	
Input 8	A8	B8	
Output	Output A	Output B	

Three-Wire RTD Inputs

PD118

J3

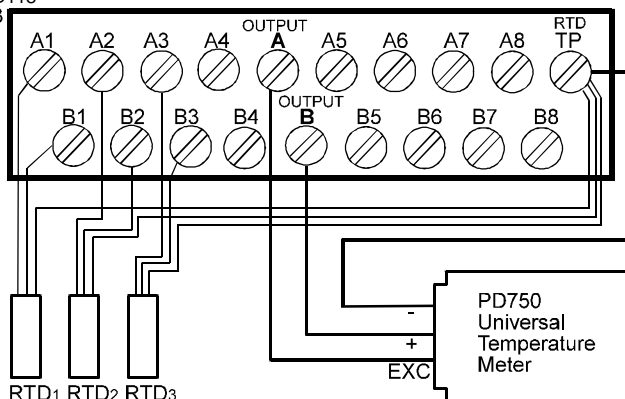

Notes:

Three-wire inputs such as thermistors and RTDs can be handled by switching the two common wires and connecting the third wire of each sensor to the RTD-TP terminal and to the temperature meter.

- Connect like color leads to terminals A1 & B1, A2 & B2, A3 & B3, etc.
- Connect odd color leads to terminal RTD-TP.
- Connect outputs A, B and RTD-TP to the temperature meter.

The example above shows three 3-wire RTDs multiplexed into 1 temperature meter.

Thermocouple Inputs

PD118

J3

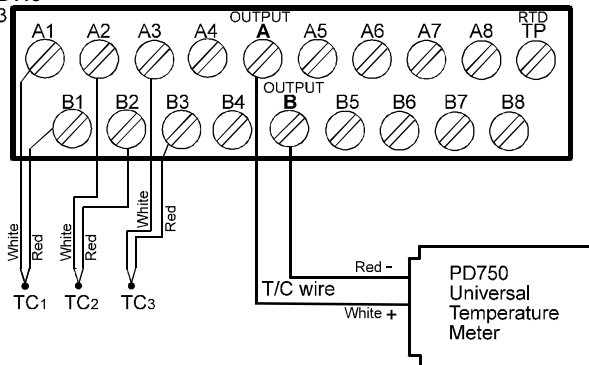

Notes:

Thermocouple wire must be used between the Minimax[®] and the meter.

The example above shows 3 type J thermocouples multiplexed into 1 temperature meter.

4-20 mA Inputs

PD118-CL

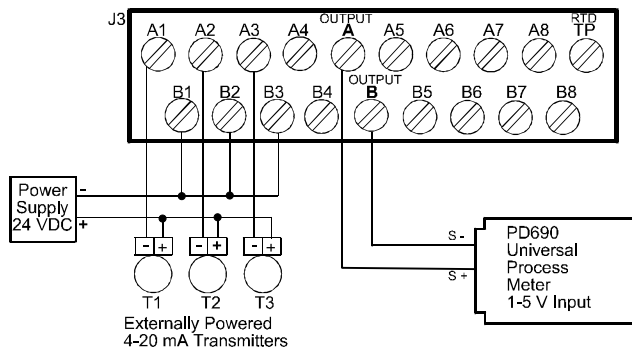

A special version of the Minimax[®] is used to switch 4-20 mA signals. The PD118-CL, has a built-in resistor network that eliminates loop interruptions. This resistor network, model PDA-CL, may be ordered separately and field installed into existing PD118s. The process meter must be setup for 1-5 V input and the complete system should be calibrated together.

PD118

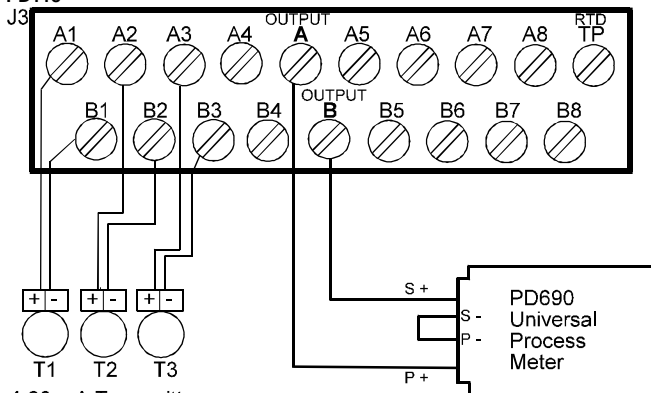

4-20 mA Transmitters
Powered by the PD690

The PD690's internal transmitter power supply may be used to power the transmitters. However, only the transmitter that is currently selected will be powered and all others will not be powered. Care should be taken to provide the transmitter with sufficient time to stabilize to provide an accurate output.

Voltage Inputs

PD118

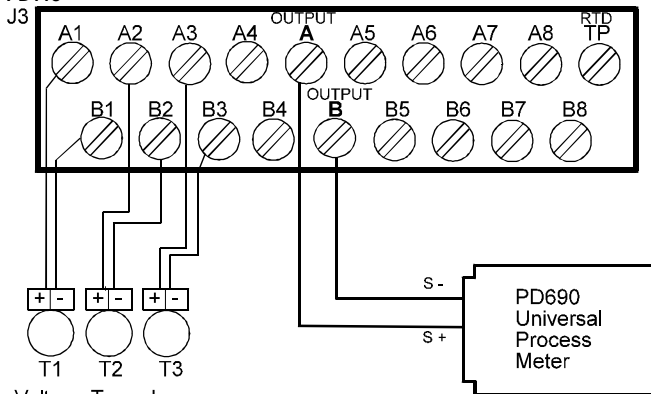

Voltage Transducers

MULTIPLE PD118 CONNECTIONS

Multiple Minimux[®] can be connected together to increase multiplexing capacity for an unlimited number of points. When connecting several units together, one unit of the group is designated the master unit and all other units function as follower units. Multiple unit configuration is simply done by connecting the units together as shown below. The system will self-determine if there are two or more Minimux[®] connected together.

No special cable is needed to connect multiple PD118s together.

There are three connections that must be made to connect multiple PD118s into a system:

1. Master/Follower Connections

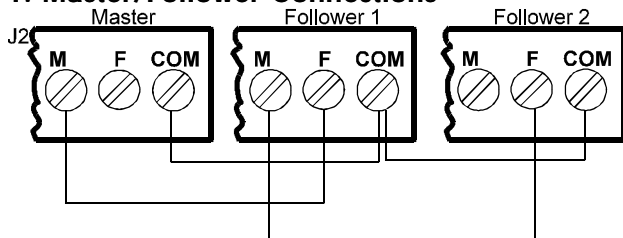

2. Multiplexer Output Signal Connections

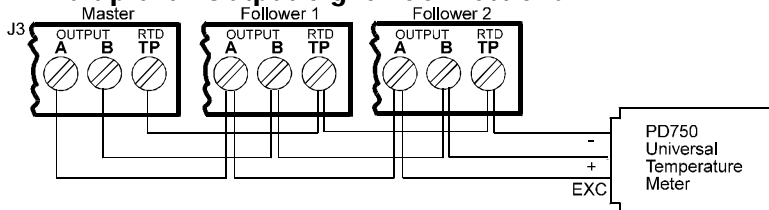

The inputs to each unit are connected as for single units. The outputs of all Minimux[®] (terminals output A, output B, and RTD-TP) are connected in parallel and then connected to the display meter.

Notes:

1. Use thermocouple wire when interconnecting a thermocouple system.
2. Terminals RTD-TP are only used in a three-wire RTD application.

3. Acknowledge & Control Connections

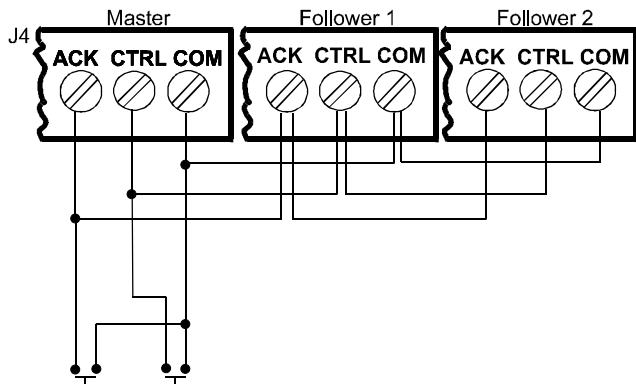

Optional external N.O. Pushbuttons
used for remote
ACK & CTRL functions.

Connecting the ACK & CTRL terminals of all units in a multiple-unit system allows the operator to control and acknowledge alarms from any unit in the system or via external switches. However, each Minimux's[®] relay will operate independently, so it may be necessary to wire them in parallel to drive a single alarm device. Also, each Minimux's[®] internal horn operates independently.

Other Connections

Connections for Power, Signal Inputs, Alarm-in, Alarm Relay, Channel Select/Channel ID are all made the same way as for single units.

ALARM-IN CONNECTIONS

Each channel on the PD118 has its own Alarm-in line that provides independent alarm indication capability for each channel. The alarm input lines of the PD118 are normally high (pull-up to 5V). Relay contacts from a Precision Digital meter or a low level logic output from a PLC can be used to drive the PD118 alarm input lines.

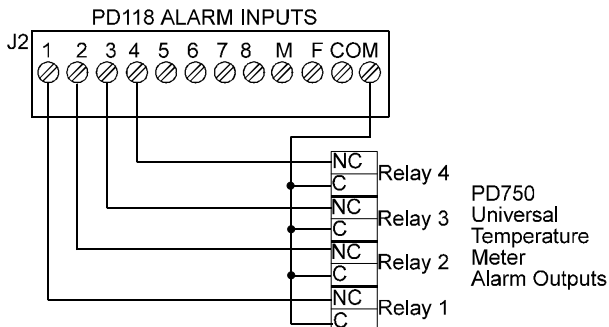

Note:

Under normal condition the NC contact of the PD750 is opened (failsafe). When the PD750 goes to alarm the corresponding relay transfers connecting the NC and C contacts together causing an alarm condition to be detected on the PD118.

ALARM RELAY CONNECTIONS

One SPDT Relay is provided with each unit. This alarm relay is common to all channels and is activated when the PD118 detects an alarm. The relay resets when the alarm is acknowledged.

Connections

Refer to the diagram below to wire up the alarm relay.

When connecting two or more Minimux[®] together it may be necessary to wire the relays in parallel to drive a single alarm device.

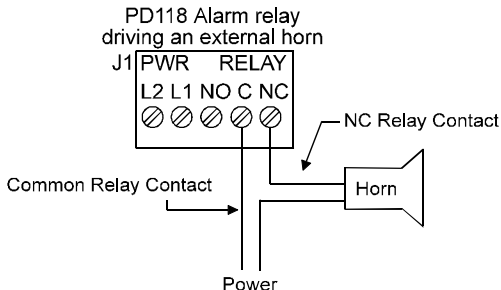

For failsafe operation, the relay is energized in the non-alarm state. In the case of a power failure, the relay will go to the alarm state, (NC contact is connected to common).

CHANNEL SELECT/CHANNEL ID CONNECTIONS

Each channel on the Minimax[®] has a Channel Select/Channel ID line which is used to either select or identify a channel on the PD118. For instance, in External Scan Mode, an external device such as a PLC can drive the Channel Select/Channel ID line for the channel it wants to see low and the PD118 will go to that channel. In Internal Scan Mode, the Channel Select/Channel ID line for the currently scanned input goes low (all others are high) to provide identification of the current channel to an external device.

The Channel Select inputs to the PD118 are normally high (pull-up to 5V). Connections are made across a Channel Select/ID Terminal and the COM terminal.

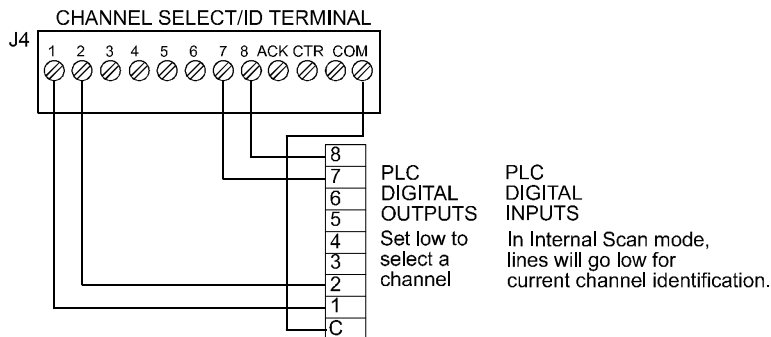
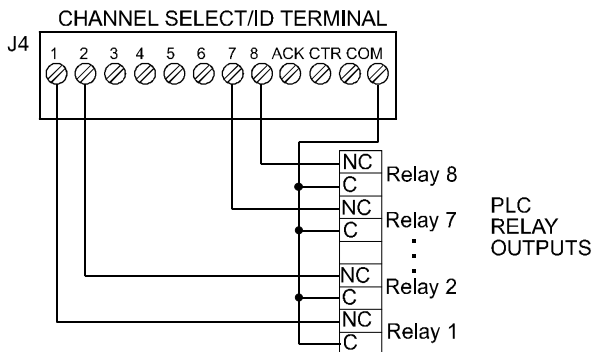

EXTERNAL ACK & CTRL CONNECTIONS

Terminals at the rear of the instrument allow the functions of the ACK and CTRL buttons to be performed externally. For instance, if the PD118 is mounted inside a NEMA 4X enclosure, switches mounted outside the enclosure could be wired to these terminals to provide the user with access to the ACK and CTRL functions.

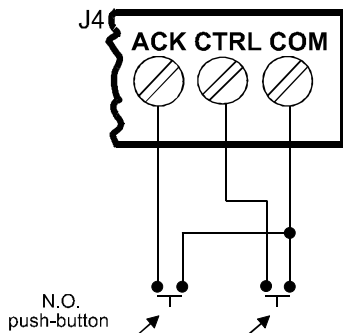

PROGRAMMING OVERVIEW

The PD118 is programmed for scanning and alarm functions using the CTRL button and a four-position DIP switch (S1). The CTRL button is used to set the dwell time for each channel (if using internal scanning) and DIP switch S1 is used to program the following:

S1 Switch:	Function:
S1-1	Sequence A or F2A alarm operation (if needed)
S1-2	Stopping-on-alarm or continuous scan-on-alarm (if needed)
S1-3	Internal or external scanning
S1-4	RUN or SETUP mode

The PD118's front cover is held in place by 6 latches that snap into notches on the cover. To remove the cover grasp it firmly on its top and bottom edges and pull it forward. The latch plate remains around the case.

DIP switch S1 is located below the right bank of LEDs. These switches program the unit for alarm Sequence A or F2A, stop-on-alarm, and for internal or external scanning.

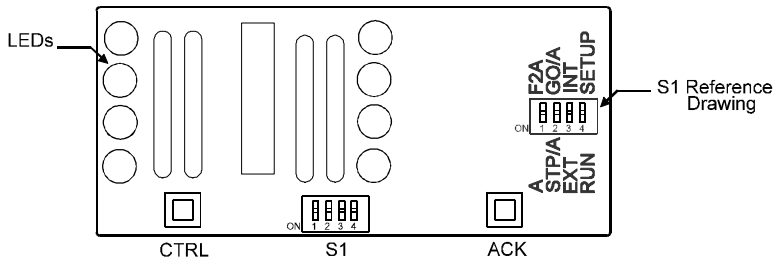

Internal or External Scanning

The PD118 is programmed for internal or external scanning with DIP switch S1-3 in the following manner:

- a. Move switch S1-3 to the EXT (on/down) position to program the PD118 for external scan control.

External scanning requires an external device such as a PLC to direct the PD118 which channel to scan by bringing that channel's Channel Select/Channel ID line low. See 'Channel Select/Channel ID' on page 18.

- b. Move switch S1-3 to the INT (off/up) position for internal scanning. Internal scanning allows the unit to automatically scan each selected channel.

Programming Dwell Time (Internal Scan Only)

The default dwell time for the PD118 is four seconds per channel and it can be adjusted for any time between 0.6 and 30 seconds per channel. A channel can be disabled from the scan sequence by programming that channel's dwell time for less than 0.5 seconds during setup.

To program a dwell time for other than the four second default or to disable a channel altogether:

- a. Set switch S1-4 to the SETUP (off/up) position.
- b. Unit will beep and channel 1 will illuminate, indicating PD118 is ready to be programmed.
- c. Dwell times are programmed with the CTRL button;
 - Press and release CTRL button within 0.5 seconds to disable a selected channel.
 - Press and release CTRL button after the 0.5 seconds beep to program channel for minimum dwell time.
 - Press and hold CTRL button for desired length of dwell time up to 30 seconds maximum.
- d. After the CTRL button is released the unit will beep and go to the next channel.
- e. Program the remaining channels in a similar fashion.
- f. When the dwell times for all eight channels have been programmed, a red LED will light up next to channels that have been disabled.
- g. To make sure the dwell times have been programmed as desired, set switch S1-4 to the RUN (on/down) position and the PD118 will begin scanning.
- h. To make any corrections to the dwell times, set switch S1-4 back to the SETUP (off/up) position and press the ACK button to advance to the desired channel.
- i. When the dwell times have been programmed as desired set switch S1-4 to the RUN (on/down) position.

Programming Dwell Time for Multiple PD118 System

The dwell times for each PD118 in a multiple PD118 system need to be programmed individually. Set switch S1-4 to SETUP (off/up) position on all units to be programmed and program the first PD118 as described above. After the first unit has been programmed, set that unit's S1-4 switch back to the RUN (on/down) mode and if the next unit's S1-4 switch is in the SETUP mode, it will be ready to be programmed. If it is in the RUN mode, all enabled channels will be scanned.

Once all PD118s in the system have been programmed and all S1-4 switches are set to the RUN (on/down) mode the scanning will begin.

Returning to Four Second Default Dwell Time

To return to the default dwell time of four seconds per channel:

- a. Turn the power off
- b. Apply power while holding the CTRL button.
- c. Release the CTRL button two seconds after power has been applied.

All dwell time programming is stored in non-volatile memory for 10 years if power is lost.

PROGRAMMING ALARM SEQUENCES

The first two positions on DIP switch S1 described on page 20 are used to program the following alarm functions:

S1 Switch:	Function:
S1-1	Sequence A or F2A alarm operation (if alarming is needed)
S1-2	Stop-on-alarm or continuous scan-on-alarm (if needed)

Selecting Alarm Sequence

The PD118 can be programmed to respond to alarm conditions either via Sequence A or Sequence F2A. Refer to page 28,29 for a description of these sequences.

S1-1 Position:	Alarm Sequence:
A (on/down)	A
F2A (off/up)	F2A

Stop or Continuous Scanning On Alarm

The PD118 can be programmed to either stop or continue scanning when it encounters a channel in alarm by setting DIP switch S1-2 in the following way:

S1-2 Position:	Function:
STP/A (on/down)	Stop-On-Alarm
GO/A (off/up)	Continuous Scan

See page 30 for further details on this function.

OPERATION

Overview

In its most basic form, the PD118 is the electrical equivalent of a double-pole, eight position automatic switch. That is, whatever input is brought into the PD118 is dwelled on for a certain amount of time while being switched back out to another device. For example, a typical application may involve switching eight type J thermocouples into a single digital panel meter.

The PD118 is made more useful by adding the ability for an external device to control the dwell times and scan sequence and the ability to indicate alarm conditions. The PLC is the most common external device that could be used to control the PD118. It can easily be programmed to make the PD118 scan any channel it wants, for as long as it wants, and in any order it wants. The PD118 can be programmed for either of two alarm sequences and it will indicate alarm conditions in three ways: a red LED lights up next to a message label, a built-in horn sounds and a 2 amp relay transfers.

Once all the connections have been made to the PD118 and it has been programmed for the particular application, it operates pretty much on its own. The only intervention it might receive from an operator would be to stop the scan on a particular channel or to acknowledge an alarm.

Internal Scan, Stop Scan & Quick-Scroll

When a PD118 has been programmed for internal scan, it automatically scans through each active channel, dwells on that channel for the programmed dwell time, while at the same time switching the signal to an external device.

While the PD118 is on a particular channel, that channel's Channel Select/Channel ID line is driven low. This provides a convenient way for a PLC to know which channel is currently being scanned.

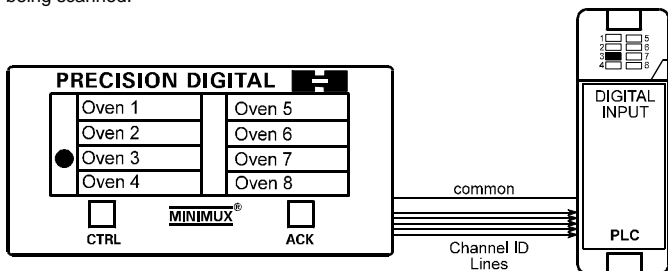

PD118 is currently scanning channel 3 and telling the PLC it is on this channel by sending Channel 3's Channel Select/Channel ID line low. All other lines are high.

Stop Scan

The PD118 can be stopped on the current channel by pressing and holding the CTRL key for more than 0.5 seconds. The PD118 will beep once to announce that scanning has stopped. To resume scanning, press and release the CTRL key quickly (less than 0.5 seconds).

Quick-Scroll

To quickly scroll through the channels press the CTRL button quickly (less than 0.5 seconds). Repeat until desired channel is reached.

External Scan

When a PD118 has been programmed for external scan, an external device such as a PLC controls the scan sequence and the dwell times. The PLC controls these two functions by sending the desired Channel Select/Channel ID line low and holding it low for as long as it wants to stay on that channel.

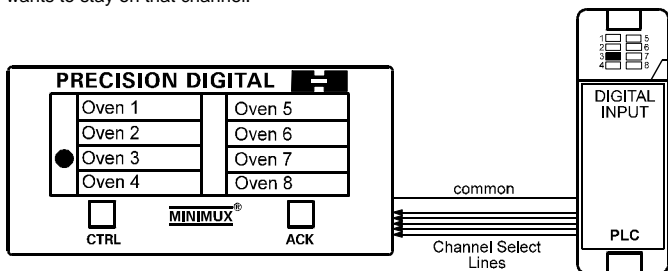

The PLC has directed the PD118 to channel 3 by sending Channel 3's Channel Select/Channel ID line low. All other lines are high.

Note:

CTRL key functions become inoperative under external scan.

Multiple Units

A system made up of multiple PD118s does not require any special setup or programming. In fact, the model number is the same for all units and they operate in the same manner as single units. There are several terminals on each PD118 in the system that have to be connected together, but this does not require a special cable. Instructions for these connections are described in the 'MULTIPLE PD118 CONNECTIONS' section on page 14.

Internal Scan

If the multiple unit system is programmed for internal scan, the scan will progress through each channel on the first PD118, move onto the first channel on the second PD118, scan through its active channels and then move onto additional PD118s in the same manner and then finally come back around to the first channel of the first PD118.

External Scan

In external scanning mode, the external device can direct the system to any channel on any PD118 at any time. For instance it could look at channel 3 on one PD118 and then channel 7 on another and then channel 5 on another.

Built-in Horn

Each PD118 has an independent built-in horn. In a multiple unit system the built-in horn of the unit where the alarm condition occurred will activate.

Alarm Relay

In a multiple unit system, only the alarm relay of the unit where the alarm occurred will transfer. The user can wire the alarm relays for all units in parallel to drive a single alarm device.

CTRL & ACK Buttons

Connecting the CTRL and ACK terminals at the rear of all units in a multiple-unit system allows the operator to control and acknowledge alarms from any unit in the system.

External CTRL & ACK Terminals

Connecting a N.O. push-button switch across all the CTRL & COM terminals in a multiple-unit system allows the operator to control the Minimux[®] at a remote location. Connecting a N.O. push-button switch across all the ACK & COM terminals in a multiple-input system allows the operator to acknowledge alarms at a remote location.

Alarms

Each channel of the Minimax[®] has an independent 'Alarm-in' terminal that allows an external device to trigger an alarm on the Minimax[®]. The external device may be the relay contacts on a digital panel meter, such as the PD750-3-14, or the digital output from a PLC. When an external device detects an alarm condition, it drives the appropriate Alarm-in line on the Minimax[®] low. When the PD118 reaches this channel, its LED will turn red and flash, the built-in horn will sound and the alarm relay will transfer.

Alarms are acknowledged by pressing the ACK button or closing a switch wired across terminals at the rear of the instrument. When an alarm is acknowledged, the horn will silence and the relay will change state. The alarmed LED (red) will not return to normal until the alarm condition has been corrected and that channel is scanned again.

The PD118 can be field programmed to react to alarm conditions in one of two ways: Sequence A or Sequence F2A (first out). Sequence A detects both momentary and maintained alarms. Sequence F2A also detects both momentary and maintained alarms as well as which alarms occurred first on a complete scan cycle.

First-out Alarms (F2A)

The main feature of Sequence F2A is its ability to indicate which alarms occurred first. In a system where all inputs are monitored simultaneously, this is a fairly straightforward concept. However, in a scanned system such as one using a PD118, where the inputs are monitored one at a time, it is not really possible to tell which alarm really occurred first. All that is known is which alarm was detected first. For this reason, **the PD118 recognizes first-out alarms as all alarms that occur during the first complete scan. This is from the time the unit detects the first alarm until the scanning goes around and passes through that first alarmed point once again. First-out alarms are indicated by flashing red LEDs. Secondary alarms are indicated by steady red LEDs.**

The PD118 detects an alarm only if the alarm is present (alarm-in line is low) while the channel is being scanned. For dwell times greater than 2 seconds, the 'alarm-in' line is poled after the PD118 has been on that channel for 2 seconds. If the dwell time is less than 2 seconds, the 'alarm-in' line is poled 0.05 seconds before the PD118 moves on to the next channel.

Alarm Indication

The PD118 indicates alarms in 3 ways: a normally green LED turns to red and flashes, an internal horn sounds, and an alarm relay transfers. The way red LEDs behave during an alarm depends on whether the PD118 was programmed to respond to alarms via Sequence A or Sequence F2A. Both of these sequences handle both momentary and maintained alarms; Sequence F2A also indicates which group of alarms occurred first.

ALARM SEQUENCE EXAMPLES

Sequence A

The PD118 is scanning all the selected inputs and is currently at channel 2, as indicated by a green LED.

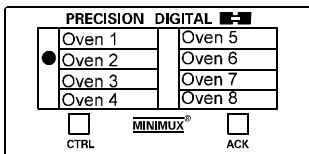

After the Minimax[®] has dwelled on channel 3 for the appropriate settling time, it poles channel 3's alarm-in line and finds it to be in alarm. The LED starts flashing orange (red and green), the horn sounds and the alarm relay transfers.

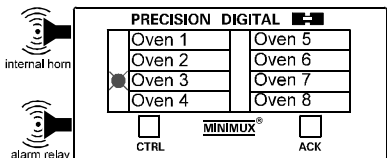

The unit continues to scan other points and an operator acknowledges the alarm. The internal horn is silenced, the alarm relay transfers, and the number 3 LED goes to steady red.

Momentary alarm

When the Minimax[®] returns to channel 3, the LED will appear orange (a combination of green and red). Before the Minimax[®] moves on to the next channel it will check the alarm-in line for channel 3 and find the alarm is gone (momentary) and turn off the red LED. Channel 3's LED will appear green before the Minimax[®] moves on to channel 4.

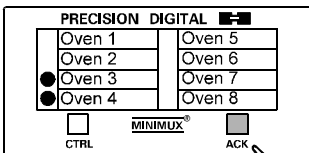

Maintained alarm

When the Minimax[®] returns to channel 3, the LED will appear orange (a combination of green and red). Before the Minimax[®] moves on to the next channel it will check the alarm-in line for channel 3 and find the alarm is still there (maintained) and it will not turn the red LED off.

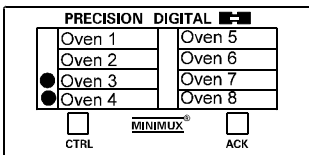

Sequence F2A

The main feature of Sequence F2A is its ability to indicate which alarms occurred first (on a scan cycle, see page 27).

The PD118 is scanning all the selected inputs and is currently at channel 2, as indicated by a green LED.

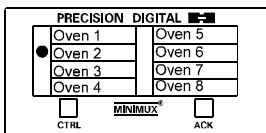

After the Minimax[®] has dwelled on channel 3 for the appropriate settling time, it poles channel 3's alarm-in line and finds it to be in alarm. The LED starts flashing orange (red and green), the horn sounds and the alarm relay transfers.

Channel 5 is also found to be in alarm and the LED flashes because it was detected during the same scan cycle that the first alarm was detected.

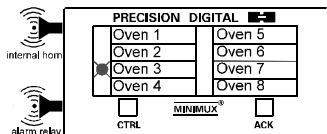

Channel 4 is found to be in alarm and is indicated by a steady LED because it was found after a complete scan of all inputs after the first alarm was detected.

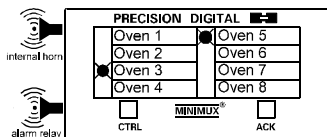

Acknowledge

The unit continues to scan and an operator acknowledges the alarm. All LEDs go to steady, the internal horn is silenced, and the alarm relay transfers. When the Minimax[®] returns to channel 3, the LED will appear orange. Just before the Minimax[®] moves on to the next channel it will check the alarm-in line and find the alarm is still there and it will not turn the red LED off.

The Minimax[®] continues to scan and again returns to channel 3, the LED will appear orange. Just before the Minimax[®] moves on to the next channel it will check the alarm-in line and find the alarm is gone and turns off the red LED. Channel 3's LED will appear green before the Minimax[®] moves on to channel 4, which will appear orange.

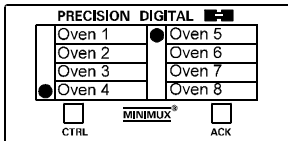
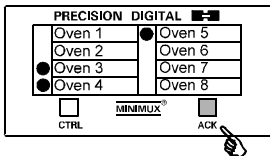
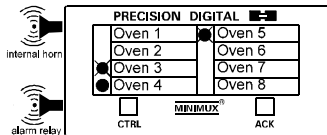

Stop-On-Alarm

The PD118 can be programmed to stop scanning when an alarm condition is detected by setting DIP switch S1-2 to the STP/A (on/down) position, as described on page 23.

If DIP switch S1-2 is in the STP/A (on/down) position, the PD118 will stop when it encounters an alarm and the LED will begin to flash orange (combination of red and green), the horn will sound and the alarm relay will transfer.

There are now two ways to proceed:

1. Acknowledge the alarm and move on to the next channel by pressing the ACK button. This will cause the horn to silence and the relay to transfer.
2. Remain on the alarmed channel and acknowledge the alarm by pressing and holding the CTRL button for more than 0.5 seconds to freeze the scan and then pressing the ACK button to acknowledge the alarm. To resume the scan, press and release the CTRL button quickly (less than 0.5 seconds).

If the original alarm has been acknowledged but has not been corrected by the time the scan reaches it again, the scan will stop, but the horn and the relay will not alarm. If the alarm condition has been corrected, the PD118 will continue scanning as normal and the red LED will turn off. If the alarm has not been corrected press the ACK button to continue scanning.

This feature is only available in internal scan mode.

TYPICAL APPLICATIONS

Application #1

Using a PD118 and a PD750 to scan 4 thermocouples.

In this example, four thermocouples are being scanned by a PD750 Universal Temperature Meter and checked for independent alarm conditions.

The PD118 Minimax[®] is programmed in the following manner to satisfy this application:

- select internal scan
- select alarm Sequence A
- stop-on-alarm is off
- program alarm dwell times:
 - channel 1 for ten seconds
 - channel 2 for five seconds
 - channel 3 for fifteen seconds
 - channel 4 for five seconds
 - channels 5-8 are disabled

The PD750-3-17 is programmed in the following manner to satisfy this application:

- select thermocouple
- select Fahrenheit
- program alarm set and reset points:
 - #1 alarm set point 150, reset point 145
 - #2 alarm set point 175, reset point 170
 - #3 alarm set point 300, reset point 295
 - #4 alarm set point 325, reset point 320

The Minimax[®] scans each channel and is currently switching input #3 to the PD750-3-17 where thermocouple #3 is reading 250°F. Relay #3 does not detect an alarm because the temperature has not reached 300°. The Minimax[®] only responds to alarm conditions detected on the currently active channel, which is why relays #1 and #2 in the PD750 have transferred, but have not been detected by the PD118.

The PD118 also avoids false alarms by detecting alarm conditions only after dwelling on a channel for 2 seconds or 0.05 seconds before it goes onto the next point, if dwelling on a channel for less than 2 seconds. This gives the PD750 time to stabilize and accurately display the temperature and check for alarm conditions.

continued on next page

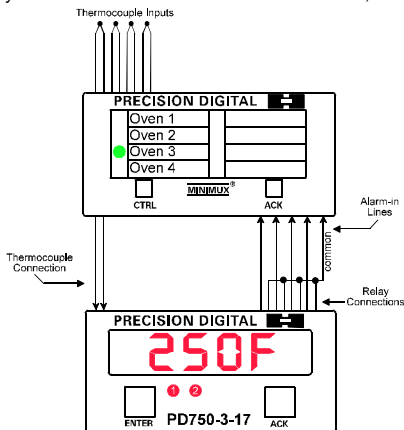

The Minimax[®] switches input #4 to the PD750-3-17 where a temperature of 345°F is found to be in alarm condition. Relay #4 on the PD750 transfers and after two seconds the PD118 detects this. The PD118 is programmed for Sequence A so channel #4 LED begins to flash orange, the internal horn sounds and the PD118's alarm relay transfers causing an external horn to sound.

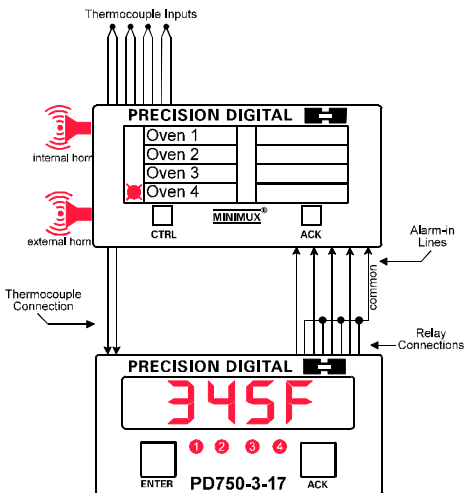

The Minimax[®] scan has moved to channel #2 where the temperature is 160°F. The operator acknowledges the alarm that occurred on channel #4 by pressing the ACK button on the PD118. This causes the internal and external horn to silence, and the #4 LED on the PD118 to go from flashing to steady red. Channel #4 will remain in alarm condition until the temperature for channel #4 falls below 320°F and the PD118 re-scans that channel.

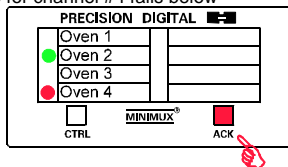

Application #2

Using a PD118, PD750 with 4-20 mA output, and a PLC to scan five RTDs

Five 100 ohm RTDs measuring stator and bearing temperatures on a motor are connected to a PD118 Minimax[®] and are being switched to a PD750. The PD750-3-15's isolated 4-20 mA output option linearizes and re-transmits each RTD signal to a PLC which controls alarming and scanning.

Each input to the Minimax[®] has a corresponding Channel Select/Channel ID Terminal which is wired to a digital output on the PLC. The PLC selects which channel to scan by setting the appropriate Channel Select/ID line low. This simple procedure allows the PLC or other device to select any channel it wants and stay on that channel for as long as it wants.

When a channel is selected by the PLC, the RTD signal is sent to the PD750-3-15 where it is converted into a 4-20 mA signal and then brought into an A/D converter on the PLC, where the signal is checked for an alarm condition. If an alarm condition exists for that channel, the PLC will send the corresponding Alarm-in Terminal low on the PD118. This causes the LED to flash, the internal horn to sound, and the PD118 alarm relay, which is connected to an external horn to transfer.

The PD118 is programmed in the following manner to satisfy this application:

- a. select external scan
- b. select alarm Sequence A

The PD750-3-15 is programmed in the following manner to satisfy this application:

- a. select RTD type
- b. select Celsius
- c. program 4-20 mA output:
 - 4 mA = 0°C
 - 20 mA = 150°C

continued on next page

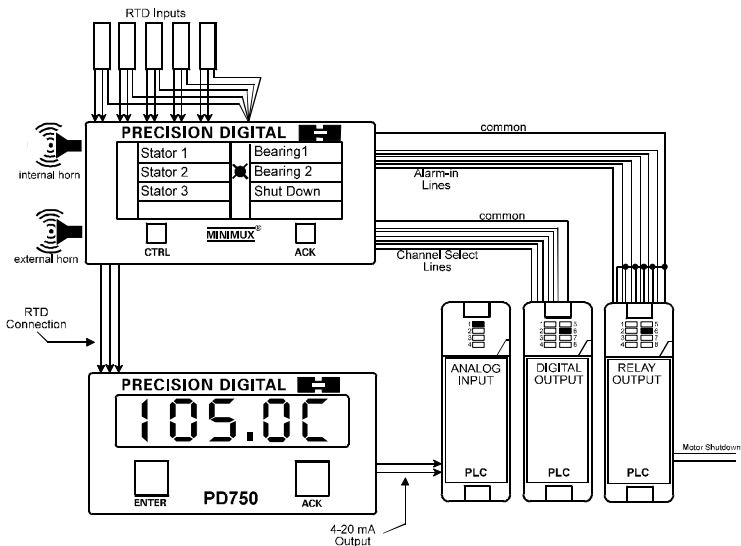

The PLC is scanning the inputs through the PD118 when it lands on channel #6 where the temperature has exceeded 100°. The PLC sends the #6 Alarm-in signal to the PD118 low which causes channel #6 LED to flash, the internal horn to sound and the alarm relay to transfer. The PLC has also been programmed to stop-on-alarm so it will stay on this channel to monitor bearing 2.

The operator acknowledged the alarm that occurred on channel #6 by pressing the ACK button on the Minimax®. This causes the internal horn to silence, the alarm relay to transfer, and the #6 LED to go from flashing to steady on.

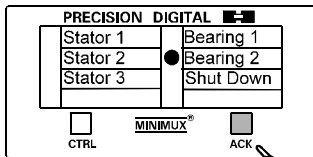

Bearing 2 temperature continues to rise and exceeds the shutdown temperature of 110°. The PLC shuts down the motor, and briefly goes to input #7 and sends its Alarm-in line low to light up the LED to indicate the motor has been shutdown. The horn goes on and the alarm relay transfers.

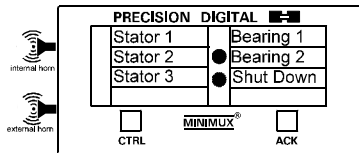

Application #3

Using Two PD118s and a PLC to scan 16 RTDs

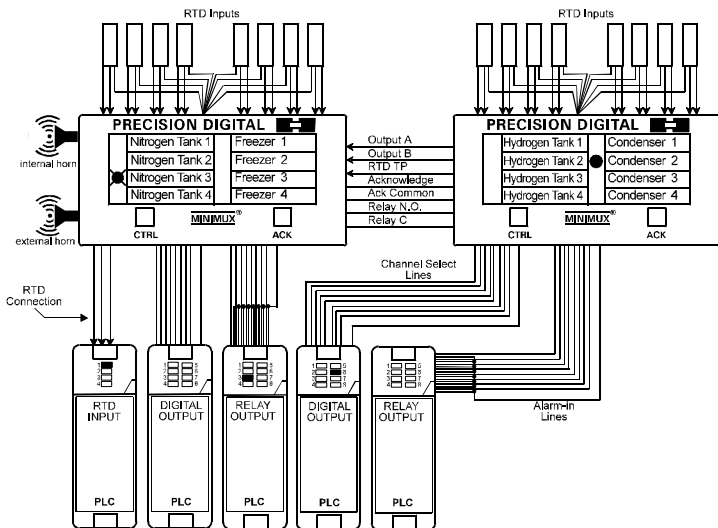

16 RTDs are connected to two Minimax[®] and switched one at a time directly into a single analog input on the PLC. Each input on the Minimax[®] has a Channel Select/ID line which is wired to a digital output on the PLC. The PLC selects which channel it wants to read by setting the Channel Select/ID line for that channel low. This simple procedure allows the PLC to select any channel it wants and stay on that channel as long as it wants. When the PLC selects a channel, the PD118 goes to that channel and sends the data for that input into the analog input on the PLC.

Alarm set points are programmed in the PLC, however the Minimax[®] is used to indicate alarm conditions. To indicate an alarm condition, the PLC drives the appropriate alarm-in line to the PD118 low. This causes the appropriate LED to flash, the internal horn to sound and the alarm relay to transfer.

Application #4

Using a PD118-CL, PLC and a PD128 to scan four 4-20 mA Inputs with a PD690 for Indication

The PD118-CL has a built-in resistor network that eliminates loop interruptions.

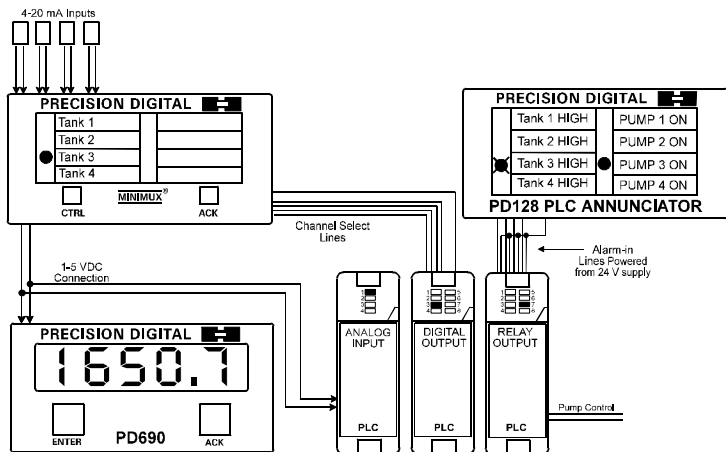

In this application, four 4-20 mA signals representing tank levels are being switched by the PD118 to a PD690 for indication and to a PLC for alarming and pump control. The PD128 PLC Annunciator is being used to indicate alarms and pump status. The PLC is controlling the scan and dwell times on each input for two seconds.

The PLC has detected that Tank 3 needs to be emptied so it turns on Tank 3's pump. The PLC is programmed to lock on this channel for 5 seconds and then take a scan through all the rest of the channels to look for other alarm conditions. If it finds another alarm condition, it will lock on that channel for 5 seconds. Even though the Minimux[®] is now locked on another channel, the operator still knows that pump 3 is ON because the 'Pump 3 On' LED is still on. If the PLC does not find any other channels in alarm it goes back to Tank 3 and stays there for 5 seconds. There are infinite other ways the PLC could be programmed to handle such applications.

PDA-CL INSTALLATION (4-20 mA Scanning)

Switching 4-20 mA signals requires that an optional resistor network (PDA-CL) be installed inside the Minimax[®] to avoid loop interruptions. This resistor network converts the 4-20 mA signal to 1-5 V. Refer to the following instructions and illustrations. To attain the best display accuracy, the reading device should be calibrated with the PDA-CL in place.

To order a PD118 from the factory with the PDA-CL installed simply call out a model PD118-CL, see page 4 for ordering information.

WARNING! Disconnect power prior to performing the following operation.

The PD118's front cover is held in place by six latches that snap into notches on the cover. To remove the front cover grasp it firmly on its top and bottom edges and pull it forward. The latch plate remains around the case.

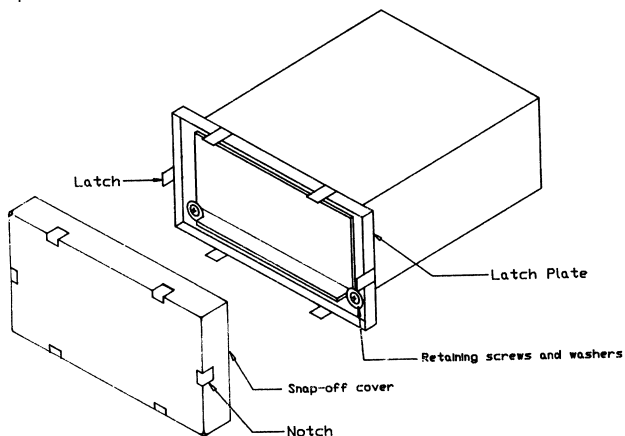

To remove the circuit board from the case, unscrew the four front panel retaining screws and remove the screw terminal connectors at the rear of the unit. Push the boards through the case by applying pressure to the circuit boards at the rear of the unit. Do not apply pressure to the vertical LED board.

The PDA-CL Current Loop Resistor Network snaps into the Resistor Network Socket RP1 located on the upper PC board. The upper board is connected to the LED board with a six pin connector.

Separate the upper PC board by holding the lower and vertical LED board together firmly and lifting the upper board straight up.

continued on next page

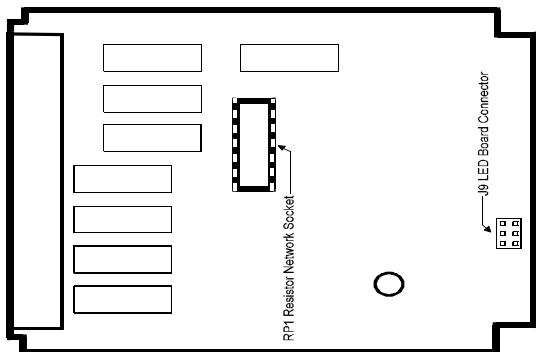

(PD118 Upper PC Board)

To install the resistor network simply press it into the socket (RP1) on the upper PC board. Check to be sure all 16 pins are seated fully into the socket (orientation is not important).

To re-install the PD118 in its case, place the upper PC board over the LED board and engage J9 socket on the upper board with J8 pins on the LED board. Insert all boards together into the case. Be sure both the top and bottom boards engage the rails which hold them in place. Do not press on the vertical LED board when seating the assembly in the case.

Install washers and retaining screws in four corners of the PD118 and install the front cover.

To order a PD118 from the factory with the PDA-CL installed simply call out a model PD118-CL, see page 4 for ordering information.

MESSAGE LABELS

Alarm message labels for the PD118 may be factory-printed at no charge, or field-printed using a laser printer with clear self-adhesive labels. Factory-printed message labels may be ordered at any time by completing the following form. (Note: message #1 is the top message on the left side and #2 is below it. Number 5 is the top message on the right side.)

Make copies of this page for additional message labels.

_____ Please include label with my order.
 _____ I have the PD118, please send ASAP.

Quantity _____
 Name _____
 Title _____
 Company _____
 Mailing Address _____
 City, St, Zip _____
 Phone _____
 Fax _____
 E-mail _____
 PO# _____

Message No. 1

--	--	--	--	--	--	--	--	--	--	--	--	--	--	--

Message No. 2

--	--	--	--	--	--	--	--	--	--	--	--	--	--	--

Message No. 3

--	--	--	--	--	--	--	--	--	--	--	--	--	--	--

Message No. 4

--	--	--	--	--	--	--	--	--	--	--	--	--	--	--

Message No. 5

--	--	--	--	--	--	--	--	--	--	--	--	--	--	--

Message No. 6

--	--	--	--	--	--	--	--	--	--	--	--	--	--	--

Message No. 7

--	--	--	--	--	--	--	--	--	--	--	--	--	--	--

Message No. 8

--	--	--	--	--	--	--	--	--	--	--	--	--	--	--



MOUNTING DIMENSIONS

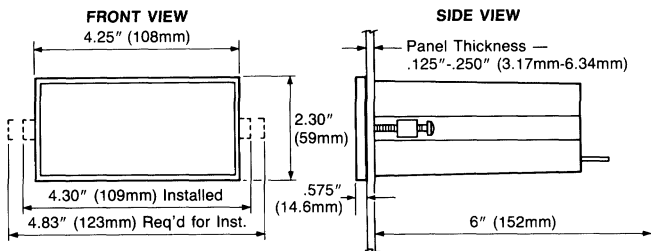

Notes:

1. Panel cutout required: 1.772 x 3.622" (45mm x 92mm) 1/8 DIN
2. Panel thickness: 0.125" - 0.250" (3.17 mm - 6.34 mm)
3. Allow 6 inches (152 mm) behind the panel
4. Weight 16 oz. (454 g)

How to Contact Us:

- For Technical Assistance please call, (800) 610-5239;
or fax (508) 655-8990
- For Sales Support or to place an order please call, (800) 343-1001;
or fax (317) 272-2873
- For Warranty Registration and Double Your Warranty on-line,
please visit our home page @ www.predig.com

LIM118 Rev B