

# **HC900 Controller Redundancy Overview & System Operation**

Doc. No.: 51-52-25-133  
Revision: 4  
Date: December 2013

---

## Notices and Trademarks

Copyright 2006 by Honeywell  
Revision 4 December 2013

### Warranty/Remedy

Honeywell warrants goods of its manufacture as being free of defective materials and faulty workmanship. Contact your local sales office for warranty information. If warranted goods are returned to Honeywell during the period of coverage, Honeywell will repair or replace without charge those items it finds defective. The foregoing is Buyer's sole remedy and is **in lieu of all other warranties, expressed or implied, including those of merchantability and fitness for a particular purpose**. Specifications may change without notice. The information we supply is believed to be accurate and reliable as of this printing. However, we assume no responsibility for its use.

While we provide application assistance personally, through our literature and the Honeywell web site, it is up to the customer to determine the suitability of the product in the application.

**Honeywell Process Solutions**  
1250 W Sam Houston Pkwy S  
Houston, TX 77042

Honeywell is a U.S. registered trademark of Honeywell

Other brand or product names are trademarks of their respective owners.

# About This Document

## Abstract

This manual gives an overview of the HC900 Redundancy architecture and products.

## References

The following list identifies all documents that may be sources of reference material for topics discussed in this publication.

Document Title	Doc ID
HC900 Process Controller Specification	51-52-03-31
HC900 Module Specification	51-52-03-41
Process Control Designer Specification	51-52-03-43
HC900 Controlware Specification	51-52-03-42
HC900 Process Controller Installation and User Guide	51-52-25-Process
HC900 Process Controller Designer User Guide	51-52-25-110
HC900 Process Controller Utilities User Guide	51-52-25-126
HC900 Process Controller Designer Function Block Reference Guide	51-52-25-109
HC900 Process Controller Communications User Guide	51-52-25-111
900 Control Station User Guide	51-52-25-148
900 Station Designer Software UG	51-52-25-149
HC900 Control System Safety Manual	51-52-25-153

## Support & Contact Information

For Europe, Asia Pacific, North and South America contact details, refer to the back page of this manual or the appropriate Honeywell Solution Support web site:









Honeywell Organization	WWW Address (URL)
Corporate	<a href="http://www.honeywell.com">http://www.honeywell.com</a>
Honeywell Process Solutions	<a href="http://www.hpsweb.honeywell.com/ps">http://www.hpsweb.honeywell.com/ps</a>
HPS Technical tips	<a href="http://hpsweb.honeywell.com/Cultures/en-US/Products/Instrumentation/hybrid/hc900/TechnicalTips/documents.htm">http://hpsweb.honeywell.com/Cultures/en-US/Products/Instrumentation/hybrid/hc900/TechnicalTips/documents.htm</a>

## Telephone and Email Contacts

Area	Organization	Phone Number
United States and Canada	Honeywell Inc.	1-800-343-0228 Customer Service
		1-800-423-9883 Global Technical Support
Global Email Support	Honeywell Process Solutions	Email: (Sales) <a href="mailto:FP-Sales-Apps@Honeywell.com">FP-Sales-Apps@Honeywell.com</a> or (TAC) <a href="mailto:hfs-tac-support@honeywell.com">hfs-tac-support@honeywell.com</a>

# Symbol Definitions

The following table lists those symbols that may be used in this document to denote certain conditions.

Symbol	Definition
	This <b>DANGER</b> symbol indicates an imminently hazardous situation, which, if not avoided, <b>will result in death or serious injury</b> .
	This <b>WARNING</b> symbol indicates a potentially hazardous situation, which, if not avoided, <b>could result in death or serious injury</b> .
	This <b>CAUTION</b> symbol may be present on Control Product instrumentation and literature. If present on a product, the user must consult the appropriate part of the accompanying product literature for more information.
<b>CAUTION</b>	This <b>CAUTION</b> symbol indicates a potentially hazardous situation, which, if not avoided, <b>may result in property damage</b> .
	<b>WARNING</b> <b>PERSONAL INJURY:</b> Risk of electrical shock. This symbol warns the user of a potential shock hazard where HAZARDOUS LIVE voltages greater than 30 Vrms, 42.4 Vpeak, or 60 Vdc may be accessible. <b>Failure to comply with these instructions could result in death or serious injury.</b>
	ATTENTION, Electrostatic Discharge (ESD) hazards. Observe precautions for handling electrostatic sensitive devices
	Protective Earth (PE) terminal. Provided for connection of the protective earth (green or green/yellow) supply system conductor.
	Functional earth terminal. Used for non-safety purposes such as noise immunity improvement. NOTE: This connection shall be bonded to protective earth at the source of supply in accordance with national local electrical code requirements.
	Earth Ground. Functional earth connection. NOTE: This connection shall be bonded to Protective earth at the source of supply in accordance with national and local electrical code requirements.
	Chassis Ground. Identifies a connection to the chassis or frame of the equipment shall be bonded to Protective Earth at the source of supply in accordance with national and local electrical code requirements.



---

# Contents

Symbol Definitions .....	iv
Introduction .....	1
Overview.....	1
Purpose of this document .....	1
What's in this document.....	1
Documentation.....	1
Purpose of the product.....	2
Product architecture .....	2
Key components.....	3
Redundant Controller Rack.....	3
CPU.....	4
Power .....	4
Redundant Switch Module (RSM) .....	4
Remote I/O Racks.....	5
Dual-Port Scanner2 Module.....	5
Power Status Module .....	5
I/O Modules .....	5
Operator Interfaces & Serial Ports.....	6
Networking .....	7
System Network.....	7
System Network Supervisory Functions .....	8
To PC Applications.....	8
To Peer HC900 Controllers.....	9
Connection options.....	9
I/O Network to Remote Racks .....	10
Device Network (Serial).....	11
Modbus Master .....	11
Modbus Slave .....	11
Modbus Master and/or Slave .....	11
Remote Access.....	11
Configuration.....	12
Lead Controller configuration .....	12
Configuration & Setup Parameters for Redundant Controllers.....	12
Reserve Controller configuration .....	12
Software .....	13

HC Designer & HC Utilities PC Software .....	13
Downloading configuration from PC to controller .....	13
Configuration storage .....	13
Configuration edits .....	13
Uploading configuration from controller to PC.....	13
Downloading to multiple controllers.....	14
Configuration backup.....	14
Configuration conversion.....	14
Monitoring configurations.....	14
Operation .....	15
Overview.....	15
Start-Up.....	15
Modes of operation .....	15
RUN Mode (Locked).....	16
RUN/PROGRAM Mode (Unlocked).....	16
PROGRAM Mode (Locked) .....	16
Steady State Operations .....	16
Execution time .....	17
Execution sequence .....	17
Lead/Reserve controller synchronization.....	17
Failover.....	18
Automatic Failover.....	18
Manual Failover .....	19
Failover Performance .....	19
Redundancy Diagnostic Monitoring.....	19
Installation .....	20
Installing the Redundant Controller Rack.....	20
Installing the I/O Racks .....	20
Installing Networking Equipment .....	21
I/O Network.....	21
Supervisory / Peer Network .....	21
Installing a Panel-Mounted Operator Interface.....	21
Honeywell OI-1042 & OI-559 .....	<b>Error! Bookmark not defined.</b>
3rd Party Panel-Mounted OI .....	21
Installing PC Hosts.....	22
Honeywell HC Designer & HC Utilities Software .....	22
Honeywell Vista Software .....	22
3rd Party PC Application Software .....	22
Troubleshooting .....	23
Diagnostic Indicators.....	23
Diagnostic Monitoring from HC Designer and HC Utilities PC Software.....	23
Status data available via Supervisory PC .....	23
Servicing.....	27
Module Replacement.....	27
C75 Module Replacement .....	27
Redundancy Switch Module Replacement .....	27



Scanner2 Module Replacement ..... 27  
 C75 Power Supply Replacement ..... 27  
 Non-Redundant Power Supply for I/O Rack Replacement ..... 27  
 Optional Redundant Power Supply for I/O Rack Replacement ..... 27  
 Power Status Module Replacement ..... 28  
 I/O Module Replacement ..... 28

Sales and Service ..... **Error! Bookmark not defined.**

## Figures

Figure 1 HC900 Redundant Controller architecture .....	2
Figure 2 Redundant controller rack components .....	3
Figure 3 Ethernet switch with redundant controller .....	7
Figure 4 Redundant Ethernet switches with redundant networks .....	8
Figure 5 Peer Data Exchange, Redundant Controllers, Non-Redundant Network .....	9
Figure 6 Peer Data Exchange, Redundant & Non-Redundant Controllers, Non-Redundant Network .....	10
Figure 7 Peer Data Exchange, Redundant Controllers, Redundant Networks .....	10
Figure 8 Connection from Lead controller to PC .....	12
Figure 9 Modes of operation on RSM .....	16
Figure 10 Lead/Controller synchronization .....	18

---

# Introduction

## Overview

### Purpose of this document

Provide an overview of the Redundant HC900 product.

### What's in this document

Topic	Page
Purpose of the Product	2
Product Architecture	2
Key Components	3
Networking	7
Configuration	12
Operation	15
Installation	20
Troubleshooting	23

## Documentation

See References on page iii.

## Purpose of the product

The HC900 Controller with redundancy minimizes the impact on a process resulting from a single failure of a critical component of the control system. Availability is improved with:

- Redundant Controller Processors - Provides redundant controllers with seamless failover under fault conditions,
- Independent power supplies for each of the Redundant Controllers,
- Redundant host networks - Provides interfaces to survive a single network failure,
- Redundant I/O Power – Provides redundant power for I/O racks on a per rack basis.

## Product architecture

The Redundant HC900 controller uses a separate rack for controller processors mounted separately from I/O Racks

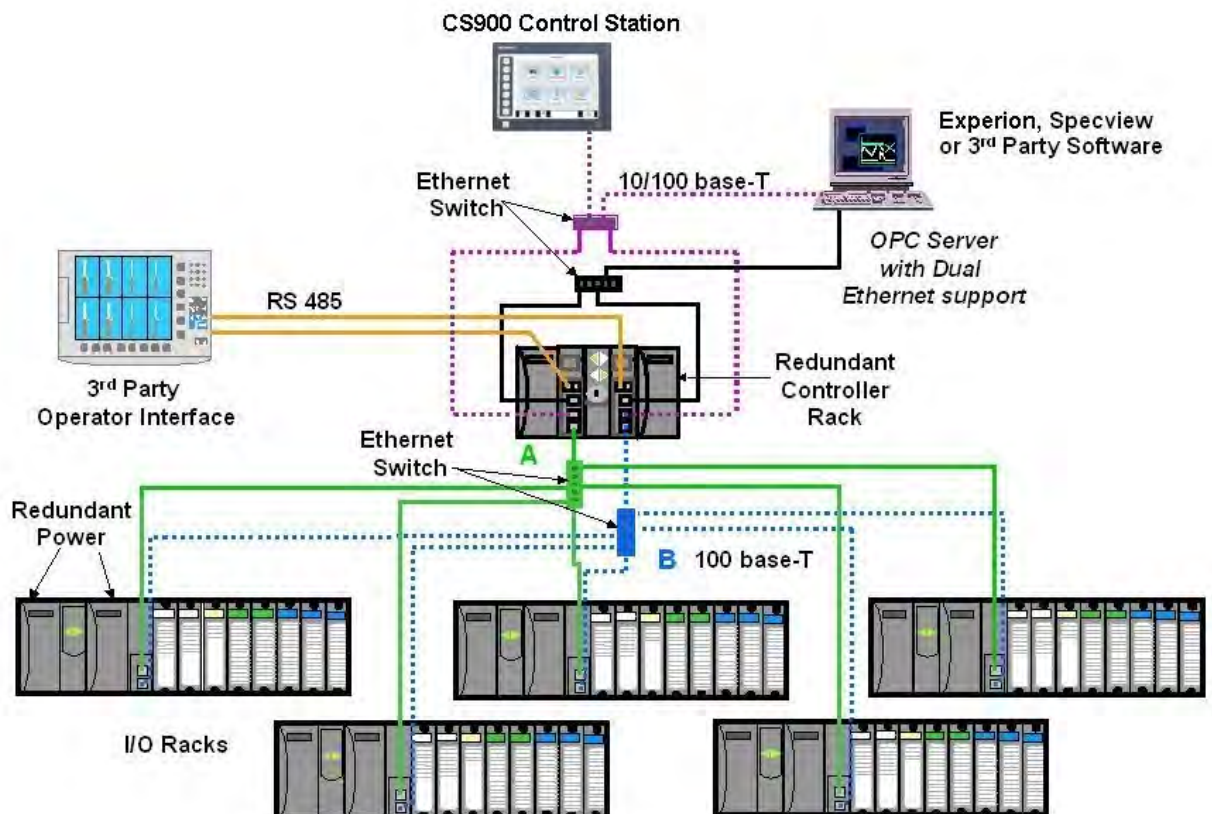
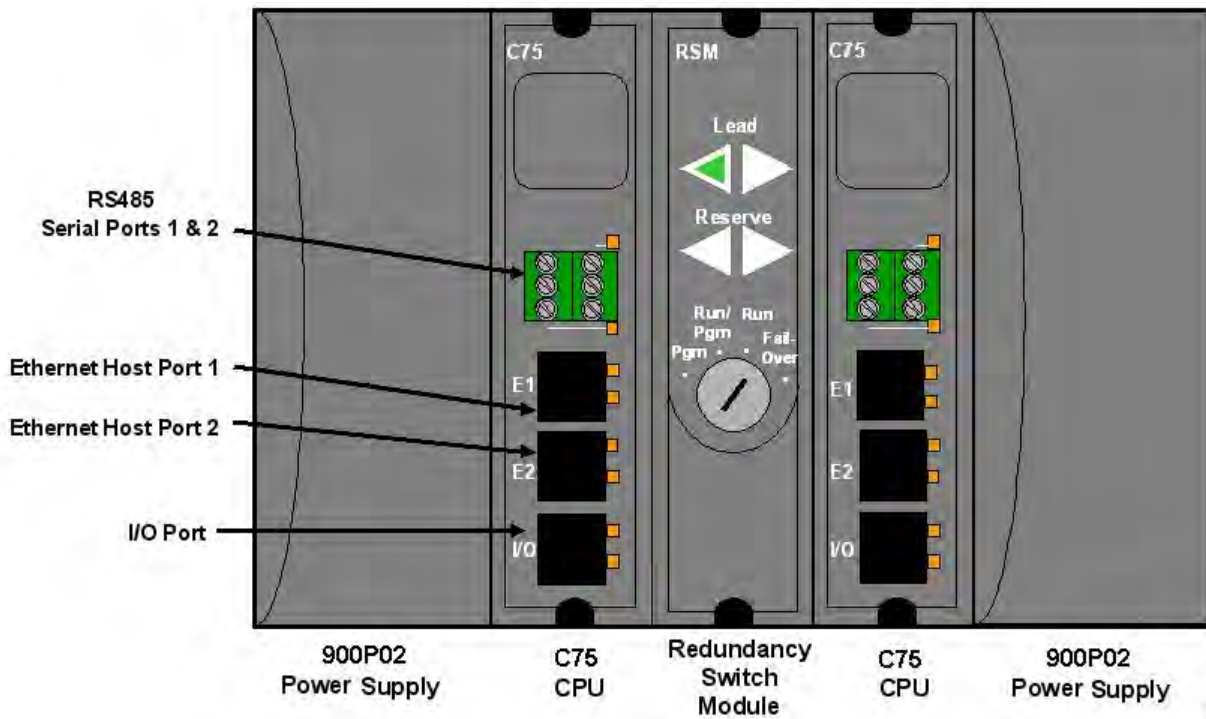

Figure 1 HC900 Redundant Controller architecture

## Key components

### Redundant Controller Rack



**Figure 2 Redundant controller rack components**

- Holds two redundant C75 CPUs, two power supplies, and one Redundancy Switch Module (RSM).
- Contains the back-plane for C75-to-C75 communications, power, and interface to RSM.
- The C75 Controller Rack does not support any I/O Modules; I/O Modules are read from and written to directly from a Scanner2 module.
- Cannot be used with C50 or C70 CPU's. C70R must be matched with another C70R CPU and must be used in 900RR0-0001racks. C75/C75S CPUs must be matched with C75/C75S CPUs and must be used in 900RR-0100 racks

## **CPU**

- Requires Scanner2 module(s)
- Reads inputs from I/O Racks through Scanner2 modules
- Executes control strategy (5000 function blocks)
- Writes outputs to I/O Racks through Scanner2 modules
- Dual Ethernet communication ports to host systems
- Each C75 Controller CPU has a dedicated, single Ethernet communication port to I/O racks
- Two RS485 serial ports – Modbus or ELN protocols for interface to OI, Modbus Host, or Modbus Slaves
- Lead Controller CPU – writes to the physical outputs; serves as the single external interface to other devices and systems (i.e., responds to requests from PC Hosts, a local Operator Interface, communicates to HC900 peers, and polls network slave devices)
- Reserve Controller CPU – executes control strategy in sync with Lead but does not write to physical outputs; does not respond to Hosts or OI.
- Reserve Controller CPU receives configuration updates and run-time data (operator entries, supervisory changes) from the Lead CPU with no manual user interaction. Configuration changes to a Reserve CPU are not permitted, except through the Lead CPU where both CPUs receive the change.
- The C75 is not recommended for non-redundant applications.

## **Power**

- Each C75 CPU has a dedicated Power Supply (two in the controller rack). Failure of the Lead CPU power supply will cause a failover condition.
- Two 900P02 model power supplies are required for the controller rack.

## **Redundant Switch Module (RSM)**

- One RSM is installed in the redundant controller rack.
- Provides indicators to identify Lead and Reserve Controller CPU's.
- Provides a key switch to set the controller mode (RUN, PROGRAM, RUN/PROG), and to force a manual failover from the Lead to the Reserve. The Reserve CPU tracks the mode selection of the Lead CPU.
- RSM may be replaced under power.

## Remote I/O Racks

- Each CPU has a separate Ethernet 100base T physical connection for up to 5 Remote I/O racks.
- Racks are available in three sizes: 4 I/O modules, 8 I/O modules, 12 I/O modules
- Systems with only one remote rack may have the remote rack connected directly to the CPU without a switching hub.
- Systems with more than one remote rack require a separate switching hub for each CPU connection. The switching hubs used in the I/O network must be Honeywell recommended industrial grade hubs.
- Remote racks require a dual-ported Scanner2 module to interface with the Redundant Controllers.
- Remote racks hold one Scanner2 module, one power supply, and up to 4, 8, or 12 I/O modules.
- The 8 and 12 Slot racks are available with a redundant power supply option. A Power Status Module (PSM) provides power supply status when two power supplies are used.
- The PSM monitors the power supply outputs and turns the green status LED off if a fault is detected.
- The load is distributed between the two supplies during normal operation when two power supplies are used.
- Racks with four I/O slots do not support the redundant power option.

## Dual-Port Scanner2 Module

- Reads inputs from the modules in the rack.
- Writes outputs to the modules in the rack.
- Has two Ethernet ports – one dedicated to each of the redundant C75 Controller CPU's
- Maintains communications with both Lead and Reserve C75 CPU's to facilitate failover.
- One Scanner2 Module is installed in each I/O Rack
- Required for the interface to C75 redundant controllers (cannot use non-redundant Scanner modules with C75 CPUs)

## Power Status Module

- Indicates current status of both Power Supplies
- May be replaced under power

## I/O Modules

- The full complement of HC900 Analog and Digital I/O modules are available for use in I/O racks using the Scanner2 module connected to redundant C75 Controller CPU's.
- Any module may be inserted into any rack slot location.
- Redundant I/O modules are not supported in the HC900 system.
- I/O modules may be replaced under power- user to take proper precautions.

## Operator Interfaces & Serial Ports

- The C75 CPU provides two RS 485 serial ports.
- Only one Honeywell Control Station may be connected to a controller.
- Lead controller communicates with the operator interface.
- Baud rates of 1200 to 115K are supported for communications to the Operator Interfaces for distances up to 2000 feet, 610M.
- The RS 485 twisted pair cable should be connected from the interface to each C75 CPUs of a redundant system to maintain communication following a failover event.
- The same serial port (S1 or S2) must be used on both CPUs of a redundant system to maintain compatibility with the common configuration.
- Failure of a lead CPU will cause the reserve CPU to assume the serial port function.
- Failure of a serial port of the Lead controller will not cause a failure of the CPU.
- The S1 and S2 serial ports may also be used to interface the controller to 3<sup>rd</sup> party operator interfaces using RS 485 and Modbus RTU slave protocol.



# Networking

## System Network

Each C75 CPU provides two 10/100base T Ethernet Host ports with Modbus TCP protocol. A total of 10 sockets are available and are shared by the two ports of the CPU for host device interfacing. Either port may be used in a non-redundant connection for host systems that do not support redundant network communications.

- Requires Honeywell (PN 50008930-001) or commercially available industrial switches, routers, etc for 10/100-baseT connection to the host/peer network. See **Figure 3**.
- Supports single or dual network interface to PC Hosts.  
Test: E1 and E2 ports must be configured for separate subnets.
- Supports single or dual network interface to peer HC900 Redundant Controllers.
- Supports single network interface to peer HC900 Non-Redundant Controllers or other Modbus/TCP devices.
- Network changes such as setting IP addresses must be made with the controller in the Program mode.  
See Modes of operation on page 15.
- Maximum distance of system network (per 10/100 baseT specification, 100 meters per segment).
- Host devices or Managed switches (if used) must be configured to Auto Negotiate (speed and duplex).

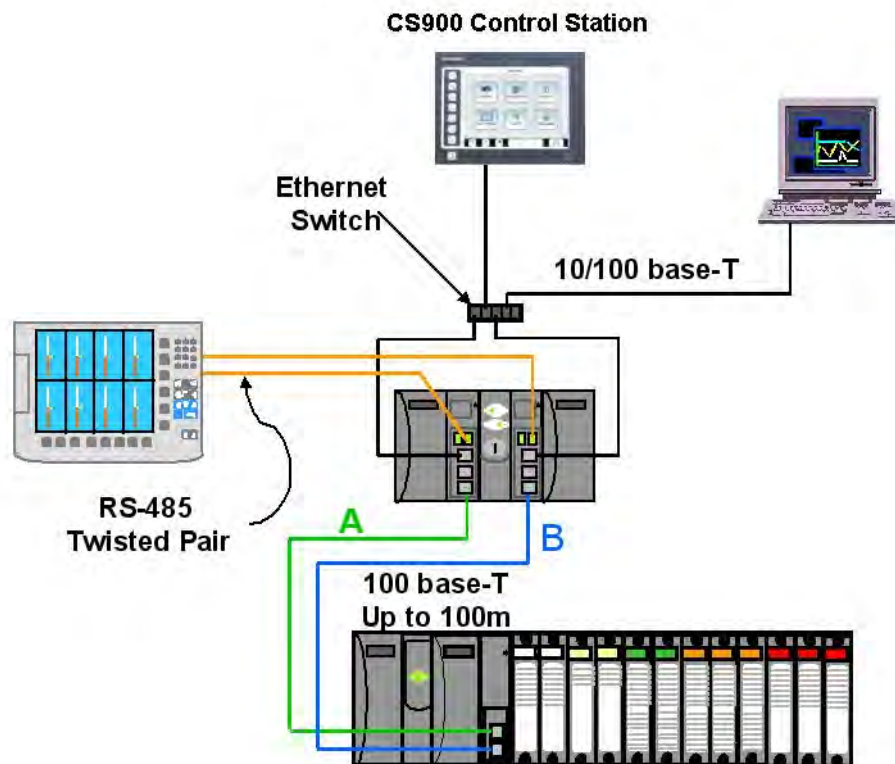

**Figure 3 Ethernet switch with redundant controller**

For applications where the host supports redundant networks, two separate Ethernet switches are required, one for each port of the CPUs. See Figure 4.

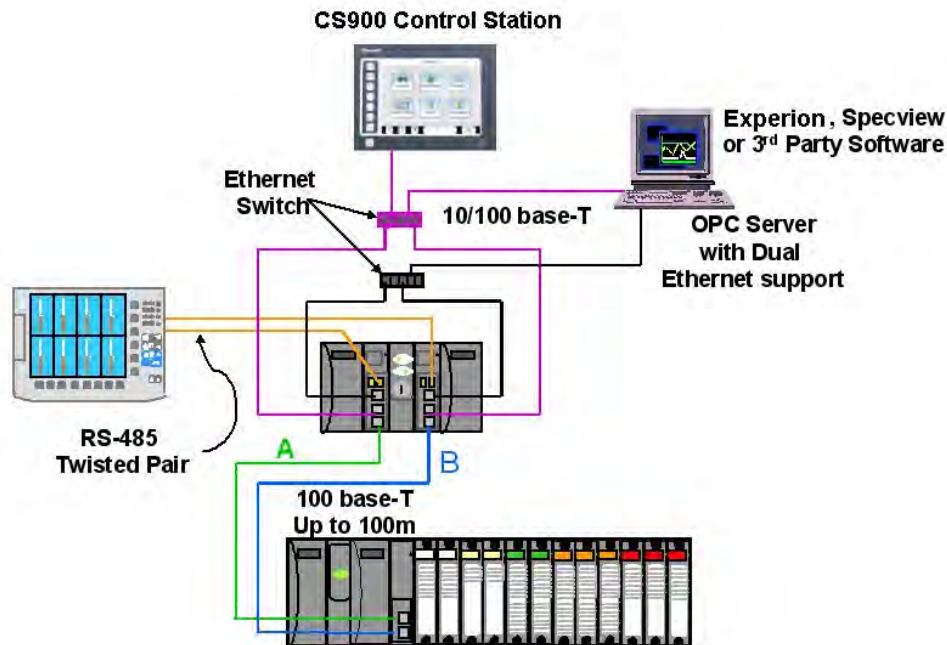

**Figure 4 Redundant Ethernet switches with redundant networks**

In this configuration a second communication path is available between the Host and the controller in the event of a Ethernet hub or connection failure.

## System Network Supervisory Functions

### To PC Applications

Network communications of a host system to the controller is directed to the Lead controller. Communication to the Reserve controller is not supported. Following a failover event, the new Lead controller assumes this function.

- Native Applications – HC Designer & HC Utilities
  - Communicate to HC900 Controllers over Ethernet
  - Applications provide a choice of either a single port to verify proper port operation, or two ports with automatic connection where the PC will use the first available port capable of communicating to the controller.
- OPC Client Applications - Honeywell's Matrikon's OPC server is a PC application with an embedded communication driver to support simplex and redundant network communications to HC900 controllers and other Modbus/TCP compatible devices. The database export files generated by Process Control Designer software may be used to transfer the database from the controller to the application, minimizing the amount of user entered data needed to apply the application. The OPC server is used to interface products such as Experion and Specview to HC900 controllers with dual Ethernet capability.
- Supports single or dual network interface to C75 CPUs
- Communicate to Honeywell Experion Software

- Communicate to 3rd Party OPC-Client aware PC applications
  - Communicate to HC900 Controllers over Ethernet
  - OPC server detects a failure of an Ethernet connection and automatically fails-over to a second port.

### To Peer HC900 Controllers

- Peer-to-Peer communications to C30, C50, C70 or other C75 Controllers
- All peer controllers must be on same subnet.
- Lead Controller handles all peer communications
- C70 and C75 peers will switch E1/E2 networks to support peer communications (assumes no non-redundant peers)
- Automatic failover of function to the new Lead Controller
- Auto-Discovery of peer network addresses; Easy to configure & set-up
- Peer controllers do not consume Ethernet sockets.
- A controller can support up to 32 peers in its configuration database.

### Connection options

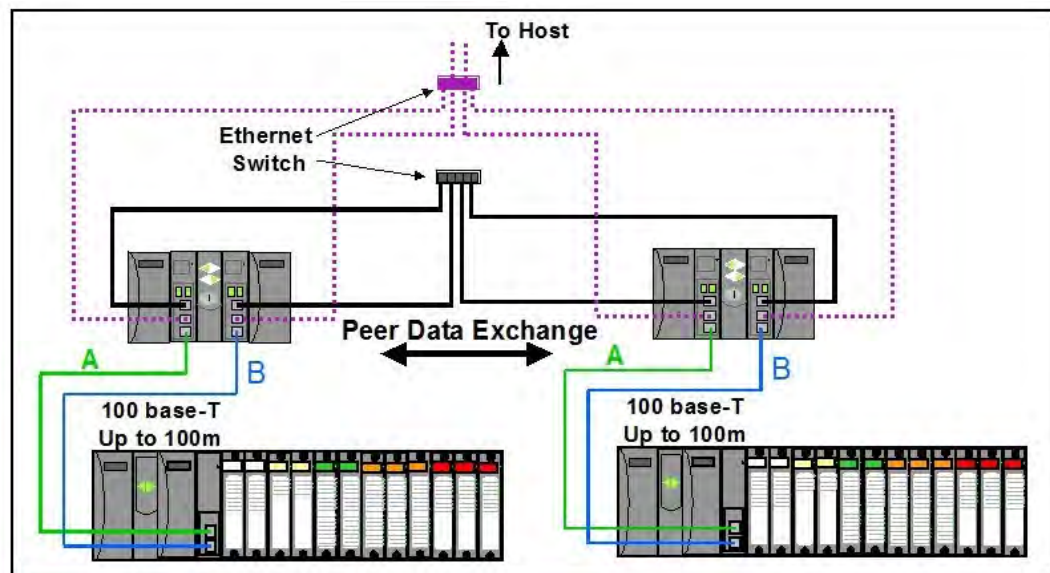

Figure 5 Peer Data Exchange, Redundant Controllers, Non-Redundant Network

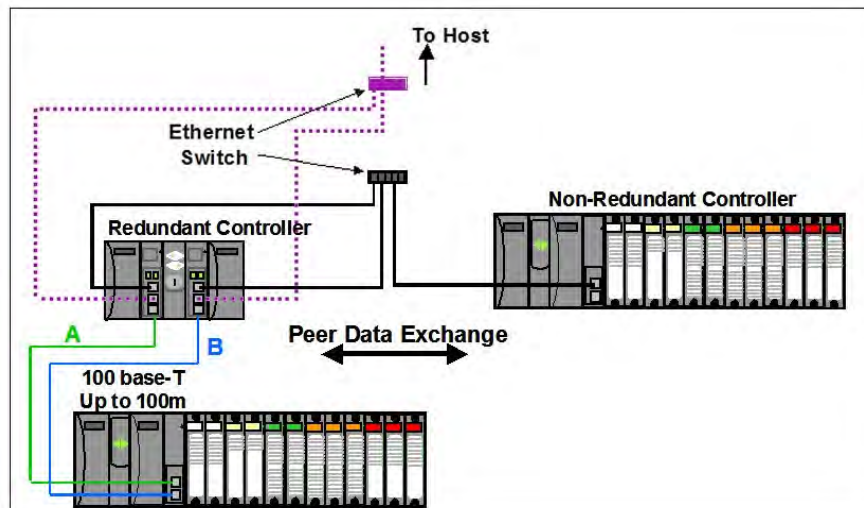

Figure 6 Peer Data Exchange, Redundant & Non-Redundant Controllers, Non-Redundant Network

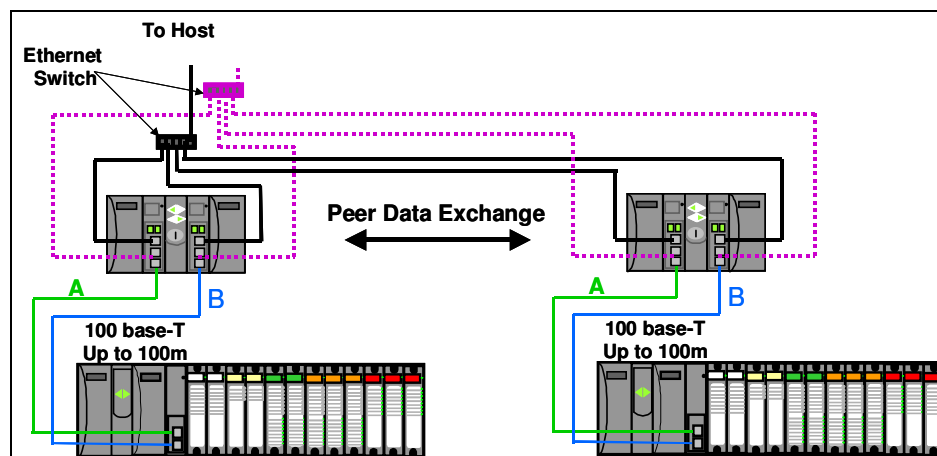

Figure 7 Peer Data Exchange, Redundant Controllers, Redundant Networks

## I/O Network to Remote Racks

- IEEE 802.4 Physical Layer Ethernet
- Two networks must be used for the I/O rack connections in a redundant system, one for each C75 CPU. See Figure 1.
- May be direct connected for single I/O rack systems.
- Two Ethernet switching hubs must also be used for installations with 2 or more I/O racks
- **Must use Honeywell recommended industrial grade switching hubs (PN 50008930-001). Performance of the system is not warranted if an alternate switching hub is used for this connection.**
- Up to 5 I/O Racks per configuration
- Separate hub required for interface from each C75 CPU

- Requires Ethernet cable: Shielded CAT5 cable with RJ-45 connectors.
- Maximum distance from Redundant Controller Rack to I/O Racks is 100 meters without hubs, 300 meters using two hubs. Fiber optic cable and switches can extend distance to up to 1500 meters.

## Device Network (Serial)

### Modbus Master

- RS-485 Serial Interface with Modbus RTU Protocol
- Two ports available, each can be set as a Master or Slave.
- Only one of the two ports may be selected for Modbus RTU Master operation.
  - The same port on each CPU must be used for this function to maintain consistency between controller configurations.
  - Both CPUs of the redundant controller should be connected to the slave devices.
- Up to 32 Slave Devices supported per configuration.
- Up to 1024 total slave register addresses supported per configuration.

### Modbus Slave

- The two serial ports of the C75 CPU may each be set to RS 485 or RS 232 and Modbus slave operation.
- Supports data exchange with an external Modbus master such as a local operator panel or PC application.
- Port connections to redundant C75 CPUs should be made to both CPUs in the rack.
- Uses same local Modbus unit address for both RS 485 serial ports of the two C75 CPUs.
- A modem configuration selection extends the 3-character timeout limit of Modbus protocol for remote access.

### Modbus Master and/or Slave

- Lead Controller transmits on the link.
- Automatic failover of Master/Slave functions to the new Lead Controller.
- Failure of the Modbus Master serial port of the Lead Controller will not cause a failover of the CPU.
- Supports transmission speeds from 1200 to 115200 baud.
- Up to 609 Meters, 2000 feet, total network length

## Remote Access

- Requires an external modem.
- Available with HC Designer software.
- Lead Controller provides communications.

# Configuration

## Lead Controller configuration

- Develop the initial control strategy or convert C30, C50 or C70 configurations.
- Make incremental changes to existing control strategies as required.
- Upload & Download a control strategy from the PC.

## Configuration & Setup Parameters for Redundant Controllers

- Upon initial power-up, prior to configuration, either CPU may be assigned Lead status by the system.
- Configurations are loaded into a Lead Controller only.
- The PC is connected to the Lead Controller as viewed from the indicators on the Redundant Switch Module (RSM).
- All controller data needed for synchronization between the Lead and Reserve Controllers is automatically transferred; no user-programming required.
- Single or Dual (Supervisory) Network interfaces available, no selection required.

## Reserve Controller configuration

- Controller configurations loaded into the Lead Controller are automatically transferred to the Reserve Controller.
- The Reserve Controller's status indicator on the RSM is illuminated when database synchronization exists.
- Powering a Reserve CPU with an on-line Lead Controller will trigger the Lead to reprogram the Reserve.
- If both CPUs of a redundant controller are being powered with valid configurations, but only one has the desired configuration, the CPU with the desired configuration should be powered first.

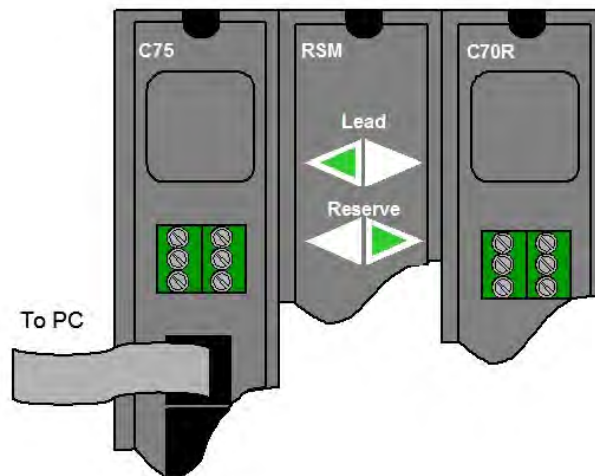

Figure 8 Connection from Lead controller to PC

---

## Software

### HC Designer & HC Utilities PC Software

- The version number of the software should be equal to or greater than the version number of the controller CPU being configured.
- The same software is used to configure both redundant and non-redundant HC900 controllers.
- Supports forward migration of existing C30, C50 and C70 configurations to the C75.

### Downloading configuration from PC to controller

- Downloading configurations to a Lead Controller can be performed using a serial port or a network port.
- The Lead Controller has two Ethernet ports, each supplied with a default IP address from the Honeywell factory.
  - Ethernet Port #1 (E1) is supplied with IP address 192-168-1-254 and Ethernet Port #2 (E2) is supplied with IP address 192-168-2-254. Users should change the default addresses to make them compatible with their local network(s). Each port must be configured for a separate subnet.
  - IP addresses entered into the Lead Controller are automatically transferred to the Reserve Controller.
- The Reserve Controller does not communicate on a network.
  - If the Reserve Controller transitions to become a Lead Controller in a system, it assumes the network communication function for the control system.

### Configuration storage

- Controller configurations downloaded to the controller are stored in battery backed RAM memory and non-volatile Flash memory.
  - The controller CPU executes its program from RAM memory. The battery backed RAM memory also stores the controller dynamic status during a loss of power to allow graceful resumption of controller operation following the interruption. If the battery is not available, startup following a power loss will use the configuration stored in Flash memory.

### Configuration edits

- On-line edits to the configuration may be downloaded to the controller.
  - On-line edits made to C75 CPU configurations are stored in both RAM and Flash memory.
  - HC Designer software lets you monitor the controller's live configuration to verify edits. All edits are made to the configuration of the Lead controller. The Reserve controller's configuration is automatically updated following a change to the Lead controller's configuration.

### Uploading configuration from controller to PC

- Controller configurations may be uploaded from the controller's RAM memory, and may include a user's annotations, eliminating the risk of selecting an inappropriate file from the PC's memory for editing when making changes to a running controller. Upload requests are serviced by the Lead Controller.

### Downloading to multiple controllers

- Controller configuration files ending with extension .cde do not include serial port and network port setups.
  - This facilitates downloading the same configuration file to multiple controllers on the same network or serial link without creating network address duplications or bus contention problems.
  - Require the port parameters to be manually entered as a separate task while HC Designer is in communication with the controller.

### Configuration backup

- Controller configurations may be uploaded and saved as Backup Files.
  - Backup files contain all of the information needed to restore a CPU to the operating conditions at the time the backup file was created, eliminating the need to for separate manual entries.
  - Useful facility to quickly get a controller back on-line following CPU replacement.
  - Backup configuration files use file extension .cbk.

### Configuration conversion

- Configurations built for use with C30, C50 or C70 CPUs may be saved and downloaded into C75 CPUs following a file conversion performed using the appropriate version of HC Designer software.
  - To convert a C30 or C50 configuration files for used with C75 CPUs, open the files to be converted using HC Designer and perform a “Save As” operation and select a C75 file type.

### Monitoring configurations

- Monitoring the configuration of the Lead Controller may be performed using Process Control Designer software.
- Controller connection via Ethernet or serial.
- When Ethernet is used, HC Designer consumes one network socket.
- While in the monitor mode, viewing the function block diagram allows the user to view the input and output values for each function block.
- Watch windows allow viewing data by parameter type and in a user specified group.
- System Monitor (ASYS) function blocks provide an output to indicate the Reserve status of the CPU.
- Redundant controller status may be monitored from HC Designer.
- A redundancy icon is provided to allow access to information in the monitor menu.
- Selections under the Utilities Tab allow users to view diagnostic status and perform maintenance level activities.



---

# Operation

## Overview

In a redundant HC900 system, the Lead Controller performs all primary tasks including interfacing with remote I/O racks, communicating with a local HMI, exchanging data with peer controllers, interfacing with Modbus slave devices, and communicating with a Host PC application. Detection of a fault or removing power from a Reserve Controller will initiate a diagnostic prompt in the Lead Controller, but will have no impact on the process under control. The detection of a fault or removing power from a Lead Controller will initiate failover, that is, transfer all primary tasks to the available Reserve Controller, establishing this controller as the new Lead. Following a failover, the new Lead Controller will remain the Lead, even if the condition that caused the failover is corrected.

## Start-Up

- Assignment of Lead and Reserve status is determined at start-up
  - First available C75 assumes Lead
  - In case of a tie, CPU mounted in the left position of the rack will Lead
  - No user configuration or manual operations required to establish Lead / Reserve status
- Lead Controller assumes control of I/O and all external communication interfaces.
- Reserve Controller receives the configuration from the Lead Controller

## Modes of operation

The modes of operation are:

- Run
- Run/Program
- Program

You can change modes with:

- key-switch on the redundancy control module
- HC Designer software
- HC Utilities software
- a command from a supervisory host (address 0000h, bit 6)

Both Lead and Reserve Controllers maintain the same mode. Placing the Lead Controller into the Program mode will also place the Reserve Controller in the Program mode.

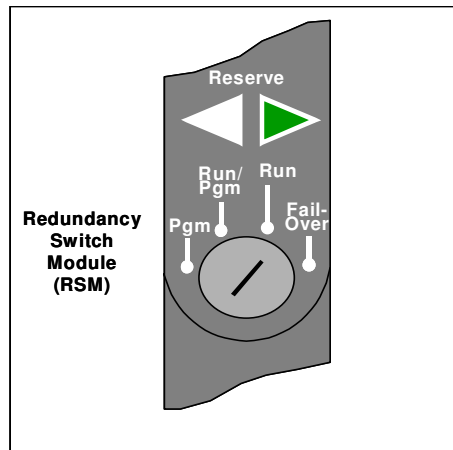

**Figure 9 Modes of operation on RSM**

### **RUN Mode (Locked)**

In the Run mode, the controller performs all control and communication tasks needed for steady-state operation. On-line configuration edits and configuration changes are inhibited.

### **RUN/PROGRAM Mode (Unlocked)**

In the Run/Program mode, steady-state tasks are executed and on-line configuration edits are permitted. Configuration changes made in this mode are retained in both RAM and Flash memory in the controller.

### **PROGRAM Mode (Locked)**

In the program mode, all outputs are turned OFF, function blocks do not execute and configuration changes are permitted. Exiting the Program Mode performs a cold-start, which clears all timers, counters, totalizers and other function blocks with residual data. Function blocks are initialized to their initial state with no reference to previous history. Exiting the Program mode updates the RAM and Flash memory of the controller with the most recent configuration data.

## **Steady State Operations**

- Lead Controller issues polls to I/O Racks for inputs
- Both Lead and Reserve read I/O responses from I/O Racks
- Lead and Reserve both execute function blocks in the control strategy
- Only the Lead Controller writes physical outputs to the I/O Racks
- Lead Controller responds to communication messages from host devices on the Supervisory Network and RS-232/RS-485 interfaces
- Lead Controller handles communications with HC900 peers
- Lead Controller handles communications with Modbus RTU slave devices
- Lead and Reserve exchange system status data to determine conditions for failover.
- I/O Scanners relay system status data between each Controller to determine conditions for failover

---

## Execution time

HC900 Controllers are designed to execute control functions within fixed scan cycles for analog data types and logic data types. In redundant controllers, the minimum scan time is 500ms for analog data types and **53ms** for logic data types; scan time varies depending on configuration.

## Execution sequence

- The type of control functions executed during a scan is determined by the system configuration.
  - Controller configurations contain a series of algorithms in the form of function blocks that get executed in a fixed sequence. The first 100 function blocks are pre-assigned by the system to handle communication tasks, alarm processing, system monitoring functions, etc. and cannot be changed by the user. Starting with function block number 101, the user may select the type of function to be executed.
- The sequence of function block execution is initially determined by the sequence in which the function blocks are placed on the graphic diagram in HC Designer.
  - Final desired sequence must be set by the user to achieve proper and optimum performance.
  - Incorrect execution sequences can contribute to delays in processing outputs and/or improper or unexpected operation.
- The HC900 controller samples all inputs before the start of a controller scan.
  - Each input being used in the configuration must be assigned to a function block. The sequence order of the function block determines when in time the actual value will be updated. It is important that algorithms that need updated input values for their calculations have the inputs execute first in the sequence.
- Except for Time Proportioning Output (TPO), Three-Position-Step-Control (TPSC) and Position Proportional Output (PPO) function block types that update their physical output values while the function blocks are being executed, all physical outputs are updated at the end of a scan.

## Lead/Reserve controller synchronization

- Lead Controller automatically synchronizes the Reserve with the configuration database
  - During download of a configuration from a Host to the Lead
  - During process operation to bring a Reserve Controller from the Unavailable state to the On-Line state
- Lead Controller automatically synchronizes the Reserve with run-time data during each function block execution cycle
- Both the Lead and Reserve Controllers execute the function blocks in the control strategy, but only the Lead Controller writes the physical outputs to the I/O Racks. See Figure 10.
- The Lead and Reserve controllers exchange system status to determine conditions for failover.

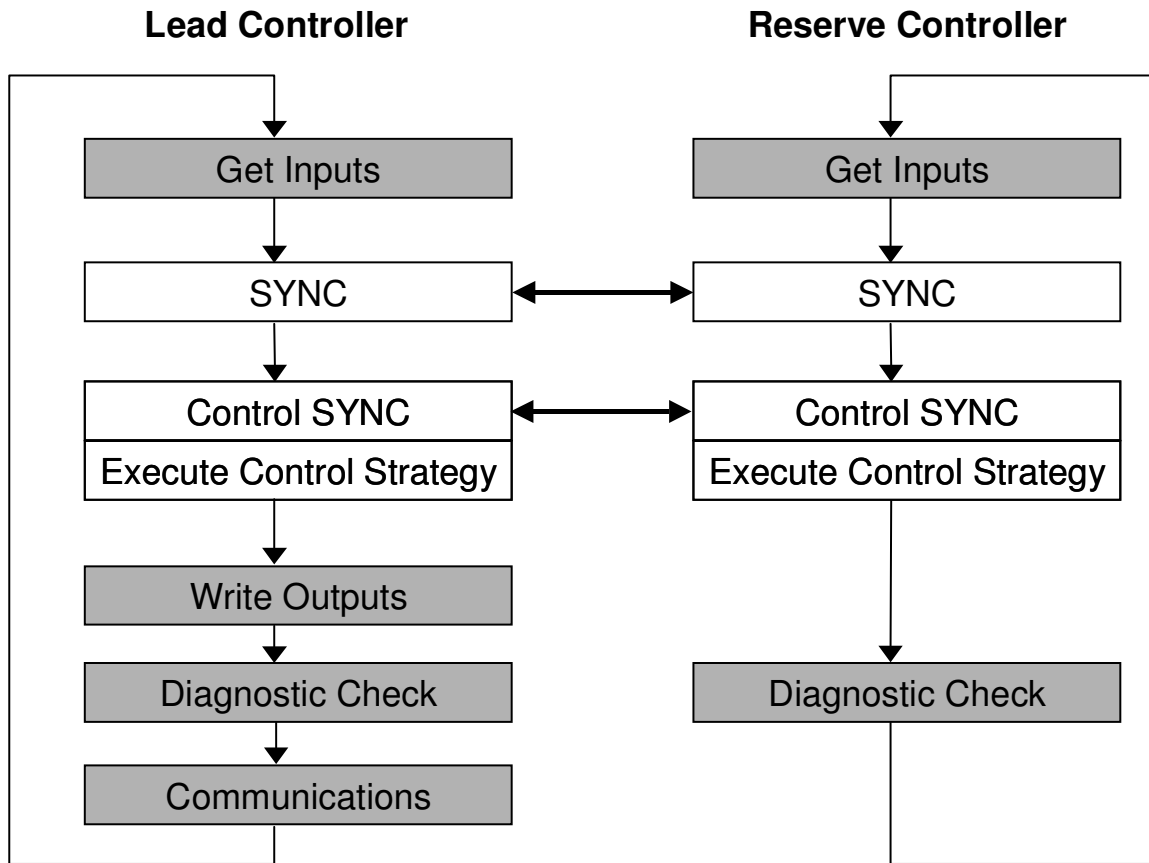

Figure 10 Lead/Controller synchronization

## Failover

### Automatic Failover

- Triggered on any of the following conditions of the Lead Controller:
  - Loss of communications with I/O Rack(s)
  - Processor exception conditions
- Error conditions that occur in the following areas will not cause a failover:
  - Loss of communications to a Host on a network
  - Loss of communications to Modbus Slave devices
  - Loss of communications to Operator Interface
  - Loss of communications with a Peer controller
- During the transition from the Lead to the Reserve, analog and digital output status is maintained at the I/O racks.

**Manual Failover**

- Via Key Switch on the Redundancy Switch Module in the Redundant Controller Rack
- Via Software Command from HC Designer & HC Utilities PC Software
- Via Software Command from Modbus / TCP & Serial Modbus RTU Hosts
- Via command from RSTAT Function Block

**Failover Performance**

Failure condition detection and failover from Lead to Reserve CPU executed in 4 analog control cycles or less.

**Redundancy Diagnostic Monitoring**

- From HC Designer and HC Utilities PC Software
  - Redundant System Status - current status of Lead/Reserve Controller CPU's
  - On-Line Monitoring, Controller Diagnostics, Communications Loop-Back tests
  - Redundant Link Status – status of communications between Lead and Reserve controllers.
  - Lead CPU status
  - Reserve CPU status
  - Scanner status

## Installation

### Installing the Redundant Controller Rack

- Rack must be installed in an enclosure and oriented for ventilation with mounting holes on top and bottom
- A Redundancy Switch Module (RSM) mounts in the center slot of the rack
- One Power Supply and C75 Controller mount to the left of the RSM
- One Power Supply and C75 Controller mount to the right of the RSM
- Ethernet ports (E1 & E2) are host network ports
- Ethernet port (labeled I/O) is the dedicated I/O rack port
- An optional Honeywell Operator Interface connects to Serial port S2
- Power with over-current protection and separate disconnects should be connected to each Power Supply

### Installing the I/O Racks

- Rack must be installed in an enclosure and oriented for ventilation with mounting holes at top and bottom of rack
- When installing a single Power Supply in the rack:
  - The Power Supply mounts in the first slot on the left in the rack.
- When installing redundant Power Supplies in the proper rack to support this feature:
  - Mount the Power Status Module (PSM) to the left of the first power supply.
  - The second Power Supply installs to the left of the PSM.
- A Scanner2 CPU mounts to the right of the Power Supply.
- I/O Modules mount to the right of the Scanner2 module.
- Power with over-current protection and separate disconnects should be connected to each Power Supply.

---

## Installing Networking Equipment

### I/O Network

- Required for configurations using multiple I/O Racks; Not required for configurations using only one I/O Rack.
- Must use Honeywell qualified industrial un-managed Ethernet switches between controller rack and I/O Racks
- Follow installation instructions in HC900 Process Controller Installation and User Guide 51-52-25Process.
- Use a separate un-managed Ethernet switch for each C75 Controller CPU.
- Each Scanner2 connects to both un-managed Ethernet switches using consistent port assignments for each I/O rack.
- Only use Shielded CAT 5 cable for network connections.

### Supervisory / Peer Network

- Any Ethernet switching device that meets the specifications for the specific site can be used.
- Follow the supplier's installation instructions
- Each C75 CPU connects to each switching device
- Use consistent C75 port assignments when connecting the CPUs to their respective switching devices.
- Only use shielded CAT5 cable for Supervisory/Peer Network connections.

## Installing a Panel-Mounted Operator Interface

### 3rd Party Panel-Mounted OI

- Follow the supplier's installation instructions
- The RS-485 Serial Interface is Daisy-chained to both C75 Controllers
- Use the same serial port, S1 or S2 on both C75 CPUs.

## Installing PC Hosts

### Honeywell HC Designer & HC Utilities Software

- Operating Systems supported: Windows XP Professional, Win 7 Professional (32 and 64 bit)
- PC hardware requirements (minimum):
  - Pentium 200 MHz with 64 MB of RAM (minimum)
  - Screen resolution – SVGA (1024x768 recommended)
  - CD ROM drive (for loading software)
- Connects to the C75/C75S Controllers using Ethernet, USB to RS-485 converter or Modbus RTU
- Available on CD

### Honeywell Experion Software

- See document 51-52-03-38 Experion Specification
- Connects to the C75/C75S Controllers using Ethernet
- Interfaced through Honeywell-supplied OPC Server for redundant networks or embedded drive
- For simplex connections

### 3rd Party PC Application Software

- Interfaced through Honeywell Matrikon OPC Server
- Requires 3rd Party PC Software to be an OPC Client
- Connect to the C75/C75S Controllers using Ethernet
- OPC Server available on CD



# Troubleshooting

## Diagnostic Indicators

- LEDs on the front of each module are provided to indicate the module's health. These include:
  - C75/C75S Controller Status LEDs
  - Scanner2 Status LEDs
  - I/O Module Status LEDs
- The HC900 modules use a combination of color and flashing patterns to indicate fault conditions and the type of fault detected. See the HC900 controller manual for a detailed explanation of fault conditions.
- LEDs on the front of the Redundancy Switch Module indicate the Lead/Reserve status of the two redundant C75/C75S controllers
  - Reserve indicator will flash while Reserve CPU is being updated by Lead.
  - Reserve controller is not available during this period.
- LEDs on the front of the Power Status Module indicate the status of the redundant Power Supplies for an I/O Rack
  - ON if the power supply is functioning properly
  - Off if either the 5 volt or the 24 volt source of a power supply has a fault.

## Diagnostic Monitoring from HC Designer and HC Utilities PC Software

- Monitor the current status of Lead/Reserve Controller CPU's
- View a Historical log of controller failover events
- Monitor Lead controller function block execution
- View controller diagnostic status
- Perform communications Loop-Back tests

## Status data available via Supervisory PC

- Current status of Lead/Reserve Controller CPU's
- Status of I/O Rack Power, including optional redundant power supplies

## Troubleshooting

**Note:** This table assumes the system was properly commissioned and all devices and cabling were proven and only one failure existed prior to the failover occurrence. It also assumes Honeywell recommended I/O Switches are being used and all Ethernet cables are properly shielded.

Fault Condition On Previous Lead	Detection Method / Failover Trigger	Observable Indication after failover	Corrective Action
User momentarily moves key RSM key switch to FAILOVER while in RUN or RUN/PROG	Lead detects switch in FAILOVER position	RSM arrow LEDs flip such that prior Reserve indicates it is now the Lead. The prior Lead will go through the transitions to synchronizing with the new Lead (flashing Reserve LED on the RSM) and then to ready Reserve (solid Reserve LED on the RSM).	None
FOVER Pin of the RSTAT function block	Lead detects the FOVER pin rising edge	RSM arrow LEDs flip such that prior Reserve indicates it is now the Lead. The prior Lead will go through the transitions to synchronizing with the new Lead (flashing Reserve LED on the RSM) and then to ready Reserve (solid Reserve LED on the RSM).	None
Cable between Scanner2 and I/O Ethernet switch fails hard or intermittently	Lead determines that the Reserve can communicate to more scanner2's than it can	<p>If the cable is in a failed state at the time of observation:</p> <ol style="list-style-type: none"> <li>1. On Scanner2 module look at the port's upper LED associated with prior Lead. It will be off. This port's lower LED may or may not be off depending on the nature of the cable failure.</li> <li>2. On the I/O Link Switch associated with the prior Lead look at port associated with the Scanner2. Both of this port's LEDs will be off.</li> </ol>	<ol style="list-style-type: none"> <li>1. Make sure cable is plugged into Scanner2</li> <li>2. Make sure cable is plugged into network switch</li> <li>3. Replace the cable</li> <li>4. Make sure cable is properly shielded</li> </ol>
Cable between I/O Ethernet switch and prior Lead fails hard or intermittently	Lead determines that the Reserve can communicate to more scanner2's than it can	<p>If the cable is in a failed state at the time of observation:</p> <ol style="list-style-type: none"> <li>1. On prior Lead look at the I/O port. Both of this port's LEDs will be off. If observed during the transition into the cable failure these LEDs will transition over a brief time from on to off.</li> <li>2. On the I/O Link Switch associated with the prior Lead look at port associated with the C70R. Both of this port's LEDs will be off.</li> </ol>	<ol style="list-style-type: none"> <li>1. Make sure cable is plugged into prior Lead</li> <li>2. Make sure cable is plugged into network switch</li> <li>3. Replace the cable</li> <li>4. Make sure cable is properly shielded</li> </ol>

Lead I/O Ethernet switch power supply is hard-failed	Lead determines that the Reserve can communicate to more scanner2's than it can	On the I/O Link Switch associated with the prior Lead all of its LEDs will be off.	Apply power to this I/O Link Switch
Lead I/O Ethernet switch electronics failure	Lead determines that the Reserve can communicate to more scanner2's than it can	If the switch is in a failed state at the time of observation: 1. On this I/O Switch check the LEDs for abnormal activity 2. On each Scanner2 check the LEDs for abnormal activity 3. On the prior Lead check the LEDs for abnormal activity	1. Replace the Switch with a Honeywell recommended Switch 2. Check for and correct any improper grounding.
Lead I/O Ethernet switch is power cycled.	Lead determines that the Reserve can communicate to more scanner2's than it can	The I/O Link Switch associated with the prior Lead will show all its LEDs off while power is off and then should return to normal operations after power is re-applied (unless the switch was damaged during the power cycle)	1. Investigate why power was temporarily lost 2. Check that the switch is operating properly. Replace if it is not. 3. Check for and correct any improper grounding.
Scanner2's I/O port to prior Lead failed hard or intermittently.	Lead determines that the Reserve can communicate to more scanner2's than it can	If the port is in the failed state at the time of observation: 1. On Scanner2 module look at the port's LEDs associated with prior Lead. One or both should be off.	Replace the Scanner2 module
I/O port on the prior Lead failed hard or intermittently.	Lead determines that the Reserve can communicate to more scanner2's than it can	If the port is in the failed state at the time of observation: 1. On prior Lead look at the port's LEDs associated with prior Lead. One or both should be off.	Replace the prior Lead C70R module
Lead C70R lost power	Reserve is not receiving data messages from the Lead, AND Reserve is not receiving any replies from any Scanner2's, AND Reserve is not sensing the physical presence of the Lead	On RSM module both LEDs for the prior Lead Controller will be off and all LEDs will be off on the Lead Controller. The associated power supply module's LED will also be off.	Restore power to prior Lead C70R

<p>Power was cycled to Lead C70R</p>	<p>Reserve is not receiving data messages from the Lead, AND</p> <p>Reserve is not receiving any replies from any Scanner2's, AND</p> <p>Reserve is not sensing the physical presence of the Lead</p>	<p>On RSM module Reserve LED for the prior Lead C70R will be on to indicate it is a ready reserve or it will be flashing to indicate it is synchronizing with the Lead prior to becoming a ready reserve.</p>	<p>Investigate why power was temporarily lost</p>
<p>Lead C70R resets due to CPU exception occurrence</p>	<p>Reserve is not receiving data messages from the Lead, AND</p> <p>Reserve is not receiving any replies from any Scanner2's, AND</p> <p>Reserve is not sensing the physical presence of the Lead</p>	<p>On RSM module Reserve LED for the prior Lead C70R will be on to indicate it is a ready reserve or it will be flashing to indicate it is synchronizing with the Lead prior to becoming a ready reserve.</p>	<ol style="list-style-type: none"> <li>1. Replace the C70R module</li> <li>2. Check and correct improper grounding</li> </ol>
<p>Lead C70R hard or intermittent unit failure</p>	<p>Reserve is not receiving data messages from the Lead, AND</p> <p>Reserve is not receiving any replies from any Scanner2's, BUT</p> <p>Reserve is still sensing the physical presence of the Lead</p>	<ol style="list-style-type: none"> <li>1. RSM module will indicate the prior Reserve is now the Lead</li> <li>2. The prior Lead may be in one of several observable states ranging from being unpowered to being an unavailable Reserve.</li> </ol>	<ol style="list-style-type: none"> <li>1. Replace the C70R module</li> <li>2. Check and correct improper grounding</li> </ol>
<p>Very high burst of network traffic on E1 and/or E2 ports</p>		<ol style="list-style-type: none"> <li>1. RSM module will indicate the prior Reserve is now the Lead</li> <li>2. The prior Lead may be in one of several observable states ranging from being unpowered to being an unavailable Reserve.</li> </ol>	<p>Analyze network traffic to check for any periods of high traffic</p>

---

## Servicing

### Module Replacement

- Servicing a failed module is accomplished by replacing only that module

### C75 Module Replacement

- Power for the module should be turned off during replacement.
- Replacement module must have same firmware revision
- Does not impact the other C75/C75S CPU module, which will continue to control the process
- Contains start-up diagnostics after replacement to verify proper operation
- If there is a Lead Controller, the configuration database is automatically copied from the Lead to the newly replaced C75/C75S 5 CPU module.

### Redundancy Switch Module Replacement

- May be removed or inserted under power
- The C75/C75S CPU modules will remain in the last used mode while the Redundancy Switch Module is removed.
- Does not induce a controller failover during replacement

### Scanner2 Module Replacement

- Power to the rack to be turned off during replacement. **Lost of communication to the IO rack will result in the IO modules going to the configured fail safe state.**
- Caution field power may still be present on the IO modules.
- Redundant controllers will operate with the affected I/O in failsafe state during Scanner2 module replacement
- Does not impact other I/O Racks in the same configuration, unless configured to do so.
- Contains start-up diagnostics after replacement to verify proper operation

### C75/C75S Power Supply Replacement

- Requires power for the module to be turned off during replacement, which supplies power to a single C75/C75S CPU
- Does not impact the Lead C75/C75S CPU module, which will continue to control the process

### Non-Redundant Power Supply for I/O Rack Replacement

- Requires power for the module to be turned off during replacement, which supplies power to a single I/O Rack

### Optional Redundant Power Supply for I/O Rack Replacement

- Requires power for the module to be turned off during replacement
- Power is maintained for the I/O Rack by the other Power Supply of the redundant pair

---

### **Power Status Module Replacement**

- May be removed or inserted under power
- No impact on the Scanner2 or I/O modules during replacement

### **I/O Module Replacement**

- May be removed or inserted under power
- Removable terminal blocks preserve field wiring during module replacement
- Removal of the module is detected by the Scanner2 and a diagnostic is posted
- Contains start-up diagnostics after replacement to verify proper operation



---

## Sales and Service

For application assistance, current specifications, pricing, or name of the nearest Authorized Distributor, contact one of the offices below.

### ASIA PACIFIC

Honeywell Process Solutions,  
(TAC) [hfs-tac-support@honeywell.com](mailto:hfs-tac-support@honeywell.com)

#### Australia

Honeywell Limited  
Phone: +(61) 7-3846 1255  
FAX: +(61) 7-3840 6481  
Toll Free 1300-36-39-36  
Toll Free Fax:  
1300-36-04-70

#### China – PRC - Shanghai

Honeywell China Inc.  
Phone: (86-21) 5257-4568  
Fax: (86-21) 6237-2826

#### Singapore

Honeywell Pte Ltd.  
Phone: +(65) 6580 3278  
Fax: +(65) 6445-3033

#### South Korea

Honeywell Korea Co Ltd  
Phone: +(822) 799 6114  
Fax: +(822) 792 9015

### EMEA

Honeywell Process Solutions,  
Phone: + 80012026455 or  
+44 (0)1344 656000

Email: (Sales)

[FP-Sales-Apps@Honeywell.com](mailto:FP-Sales-Apps@Honeywell.com)

or

(TAC)

[hfs-tac-support@honeywell.com](mailto:hfs-tac-support@honeywell.com)

### AMERICA'S

Honeywell Process Solutions,  
Phone: (TAC) 1-800-423-9883 or  
215/641-3610  
(Sales) 1-800-343-0228

Email: (Sales)

[FP-Sales-Apps@Honeywell.com](mailto:FP-Sales-Apps@Honeywell.com)

or

(TAC)

[hfs-tac-support@honeywell.com](mailto:hfs-tac-support@honeywell.com)

### For more information

To learn more about SmartLine Transmitters,  
visit [www.honeywellprocess.com](http://www.honeywellprocess.com)  
Or contact your Honeywell Account Manager

### Process Solutions

Honeywell  
1250 W Sam Houston Pkwy S  
Houston, TX 77042

Honeywell Control Systems Ltd  
Honeywell House, Skimped Hill Lane  
Bracknell, England, RG12 1EB

Shanghai City Centre, 100 Jungi Road  
Shanghai, China 20061

[www.honeywellprocess.com](http://www.honeywellprocess.com)



51-52-25-133 Rev.4  
December 2013  
©2013 Honeywell International Inc.

---