

**DCP 100**  
**Digital Controller Programmer**

**Installation Manual**

**Honeywell**

**DCP 100**  
**Digital Controller Programmer**  
**Installation Manual**

Ref: EN11-6173

Issue : 1

September 1996

# PREFACE

This manual is intended for use in support of installation, commissioning, configuration etc. of the Honeywell DCP 100 Digital Controller Programmer. For information on day-to-day operation, refer to the associated Operator's Manual (see below).

## Associated Documents

Title	Document No.
DCP 100 Digital Controller Programmer Operator's Manual	EN11-6174



The procedures described in this manual must be undertaken by technically competent servicing personnel.

## Contents

<b>SECTION 1</b>	<b>INTRODUCTION</b> . . . . .	<b>1-1</b>
<b>SECTION 2</b>	<b>INSTALLATION</b> . . . . .	<b>2-1</b>
2.1	Unpacking Procedure . . . . .	2-1
2.2	Panel-Mounting the Digital Controller Programmer . . . . .	2-1
2.3	Connections and Wiring . . . . .	2-4
2.3.1	Mains (Line) Input . . . . .	2-5
2.3.2	24V (Nominal) AC/DC Supply . . . . .	2-5
2.3.3	Thermocouple Input . . . . .	2-7
2.3.4	RTD Inputs . . . . .	2-7
2.3.5	Linear Inputs . . . . .	2-7
2.3.6	Digital Inputs . . . . .	2-7
2.3.7	Relay Outputs . . . . .	2-8
2.3.8	SSR Drive Outputs . . . . .	2-8
2.3.9	DC Outputs . . . . .	2-8
2.3.10	Event Outputs . . . . .	2-8
2.3.11	RS485 Serial Communications Link . . . . .	2-8
<b>SECTION 3</b>	<b>INTERNAL LINKS AND SWITCHES</b> . . . . .	<b>3-1</b>
3.1	Removing the Digital Controller Programmer from its Housing . . . . .	3-1
3.2	Removing/Replacing the Output 2/Output 3 Option PCBs . . . . .	3-3
3.3	Removing/Replacing the RS485 Communications Option PCB . . . . .	3-3
3.4	Installing/Removing the Digital Input Option PCB . . . . .	3-4
3.5	Installing/Removing the Event Output Option PCB . . . . .	3-5
3.6	Replacing the Digital Controller Programmer in its Housing . . . . .	3-5
3.7	Selection of Input Type . . . . .	3-6
3.8	Selection of Primary Output (Output 1) Type . . . . .	3-7
3.9	Output 2 Type/Output 3 Type . . . . .	3-8
<b>SECTION 4</b>	<b>CONFIGURATION MODE</b> . . . . .	<b>4-1</b>
4.1	Entry into Configuration Mode . . . . .	4-1
4.2	Hardware Definition Code . . . . .	4-1
4.3	Configuration Mode Parameters . . . . .	4-4

4.4	Alarm Inhibit Facility . . . . .	4-6
4.5	Exit From Configuration Mode . . . . .	4-6
<b>SECTION 5</b>	<b>RS485 SERIAL COMMUNICATIONS . . . . .</b>	<b>5-1</b>
5.1	RS485 Connections . . . . .	5-1
5.2	Communications Enable/Disable . . . . .	5-1
5.3	Selection of Communications Channel Address . . . . .	5-1
5.4	Communications Protocol . . . . .	5-1
5.4.1	Type 1 Message . . . . .	5-3
5.4.2	Type 2 Message . . . . .	5-3
5.4.3	Type 3 Message . . . . .	5-4
5.4.4	Type 4 Message . . . . .	5-4
5.5	Programmer Parameters (Start of Message character = R) . . . . .	5-5
5.6	Programmer Commands . . . . .	5-7
5.7	Programmer Status 1 . . . . .	5-8
5.8	Current Segment Event Status . . . . .	5-8
5.9	Power Fail Recovery . . . . .	5-8
5.10	Program/Segment Definitions . . . . .	5-8
5.11	Program Scan Table . . . . .	5-9
5.12	Segment Mode . . . . .	5-10
5.13	Programmer Status 2 . . . . .	5-10
5.14	User Tag Names . . . . .	5-10
5.15	Controller Parameters (Start of Message character = L) . . . . .	5-11
5.16	Controller Scan Table . . . . .	5-15
5.17	Error Response . . . . .	5-15
5.18	Master Communications Mode . . . . .	5-15
<b>APPENDIX A</b>	<b>PRODUCT CODES . . . . .</b>	<b>A-1</b>
<b>APPENDIX B</b>	<b>PRODUCT SPECIFICATION . . . . .</b>	<b>B-1</b>

## Tables

Table 2-1	Thermocouple Cable Colour Codes . . . . .	2-6
Table 3-1	Input Type Selection . . . . .	3-6
Table 3-2	Output 1 Type Selection . . . . .	3-7
Table 3-3	Output 2/Output 3 Type Selection . . . . .	3-8
Table 5-1	{DATA} Element - Sign/Decimal Point Position . . . . .	5-2
Table 5-2	Programmer Parameters and Identifiers . . . . .	5-5
Table 5-3	Programmer Parameters - Functions . . . . .	5-6
Table 5-4	Controller Parameters and Identifiers . . . . .	5-11
Table 5-5	Controller Parameters - Functions . . . . .	5-13

## Illustrations

Figure 2-1	Cut-out Dimensions . . . . .	2-1
Figure 2-2	Main Dimensions . . . . .	2-2
Figure 2-3	Panel-Mounting the Digital Controller Programmer . . . . .	2-3
Figure 2-4	Rear Terminal Connections . . . . .	2-4
Figure 2-5	Mains (Line) Supply Connections . . . . .	2-5
Figure 2-6	24V AC/DC Supply Connections . . . . .	2-5
Figure 3-1	PCB Positions . . . . .	3-1
Figure 3-2	Removing the Output 2/Output 3 Option PCBs . . . . .	3-2
Figure 3-3	Removing/Replacing the RS485 Communications Option PCB . . . . .	3-3
Figure 3-4	Location of Digital Input Option PCB and Event Output Option PCB . . . . .	3-4
Figure 3-5	CPU PCB (Relay/SSR Output 1) . . . . .	3-6
Figure 3-6	PSU PCB Link Jumpers . . . . .	3-7
Figure 3-7	DC Output Option PCB (Output 2/Output 3) . . . . .	3-8

## SECTION 1 INTRODUCTION

The DCP 100 Digital Controller Programmer is equipped with a universal (thermocouple, RTD or linear) input and up to three outputs (relay, SSR or linear). It can be panel-mounted in an appropriate-sized cut-out using the "no-tools" fixing strap supplied. Several instruments can be installed in a side-by-side multiple installation in one single cut-out.

The Digital Controller Programmer is front-panel configurable, enabling the user to tailor the instrument to suit the application.

The Setpoint programmer is equipped with a 96 - 264V 50/60Hz power supply as standard; a 24V AC/DC option is available.

The Digital Controller Programmer is constructed such that, once the instrument is correctly configured and installed, most changes to its use or application can be accommodated without removing it from its panel installation.

The options available on the Digital Controller Programmer include:

- \* Remote control and selection of program via a Digital Input Option PCB
- \* Second control (COOL) output
- \* Up to four Event relay outputs via an Event Output Option PCB
- \* Recorder output (setpoint or process variable)
- \* RS485 serial communications
- \* Real Time Clock

For a full list of options, refer to Appendix A.

## SECTION 2 INSTALLATION

### 2.1 UNPACKING PROCEDURE

1. Remove the Digital Controller Programmer from its packing. The Digital Controller Programmer is supplied with a panel gasket and push-fit fixing strap. Retain the packing for future use, should it be necessary to transport the Digital Controller Programmer to a different site or to return it to the supplier for repair/testing.

2. Examine the delivered items for damage or deficiencies. If any is found, notify the carrier immediately. Check that the product code shown on the label affixed to the Digital Controller Programmer housing corresponds to that ordered (see Appendix A).

### 2.2 PANEL-MOUNTING THE SETPOINT PROGRAMMER

The panel on which the Digital Controller Programmer is to be mounted must be rigid and may be up to 6.0mm (0.25 inches) thick. The cut-out required for a single DCP 100 Digital Controller Programmer is as shown in Figure 2-1.

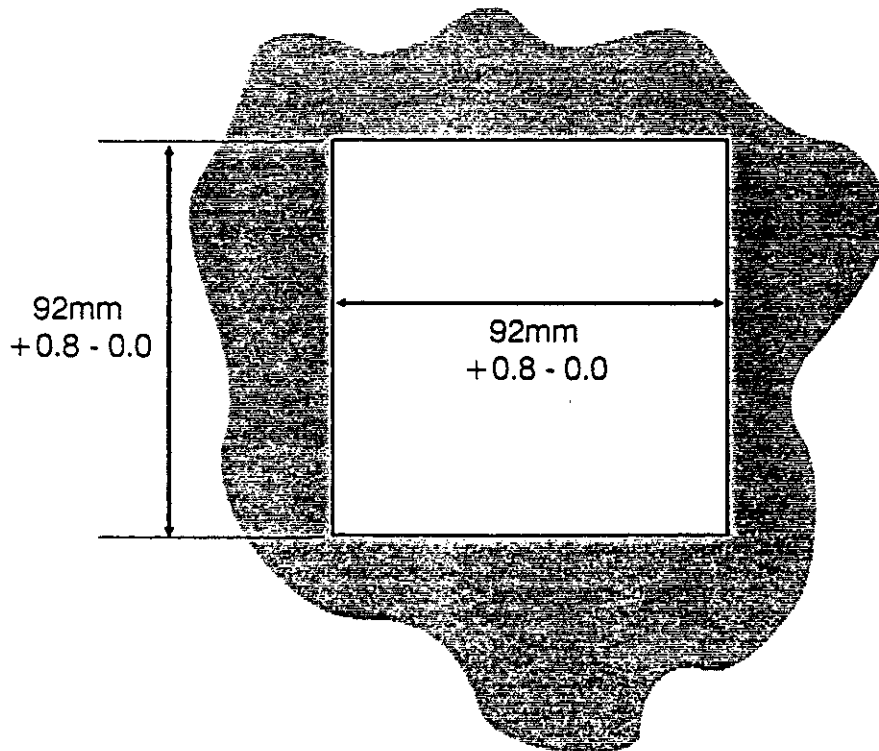

**Figure 2-1 Cut-out Dimensions**

Several units may be installed in a single cut-out, side-by-side. For  $n$  Digital Controller Programmers mounted side-by-side, the width of the cut-out would be:

$$(96n - 4) \text{ millimetres or } (7.56n - 0.16) \text{ inches.}$$



The Digital Controller Programmer is 100mm deep (measured from the rear face of the front panel). The front panel is 96mm high and 96mm wide. When panel-mounted, the front panel projects 10mm from the mounting panel. The main dimensions of the Digital Controller Programmer are shown in Figure 2-2.

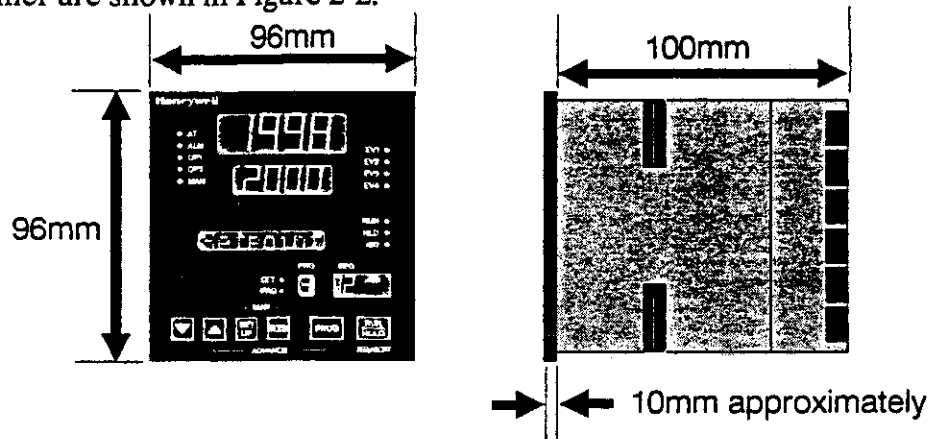

**Figure 2-2 Main Dimensions**

To panel-mount the Digital Controller Programmer:

1. Insert the rear of the Digital Controller Programmer housing through the cut-out (from the front of the mounting panel) and hold the Digital Controller Programmer lightly in position against the panel. Ensure that the panel gasket is not distorted and that the Digital Controller Programmer is positioned squarely against the mounting panel. *Apply pressure to the front panel bezel only.*

### **CAUTION**

Do not remove the panel gasket, as this may result in inadequate clamping of the instrument in the panel.

2. Slide the fixing strap in place (see Figure 2-3) and push it forward until it is firmly in contact with the rear face of the mounting panel (the tongues on the strap should have engaged in matching ratchet positions on the Digital Controller Programmer housing and the fixing strap springs should be pushing firmly against the mounting panel rear face).

Once the Digital Controller Programmer is installed in its mounting panel, it may be subsequently removed from its housing, if necessary, as described in Subsection 3.1.

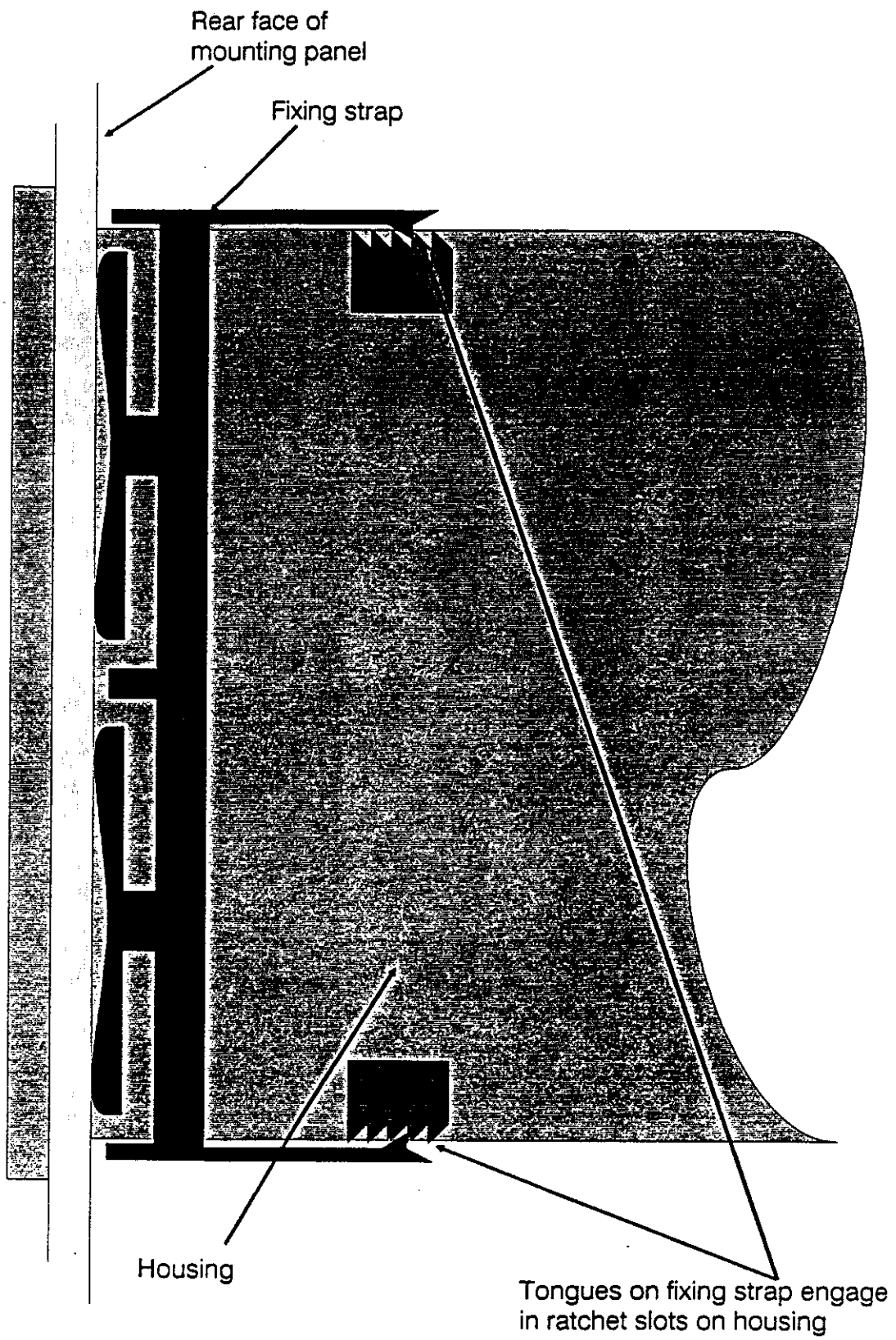
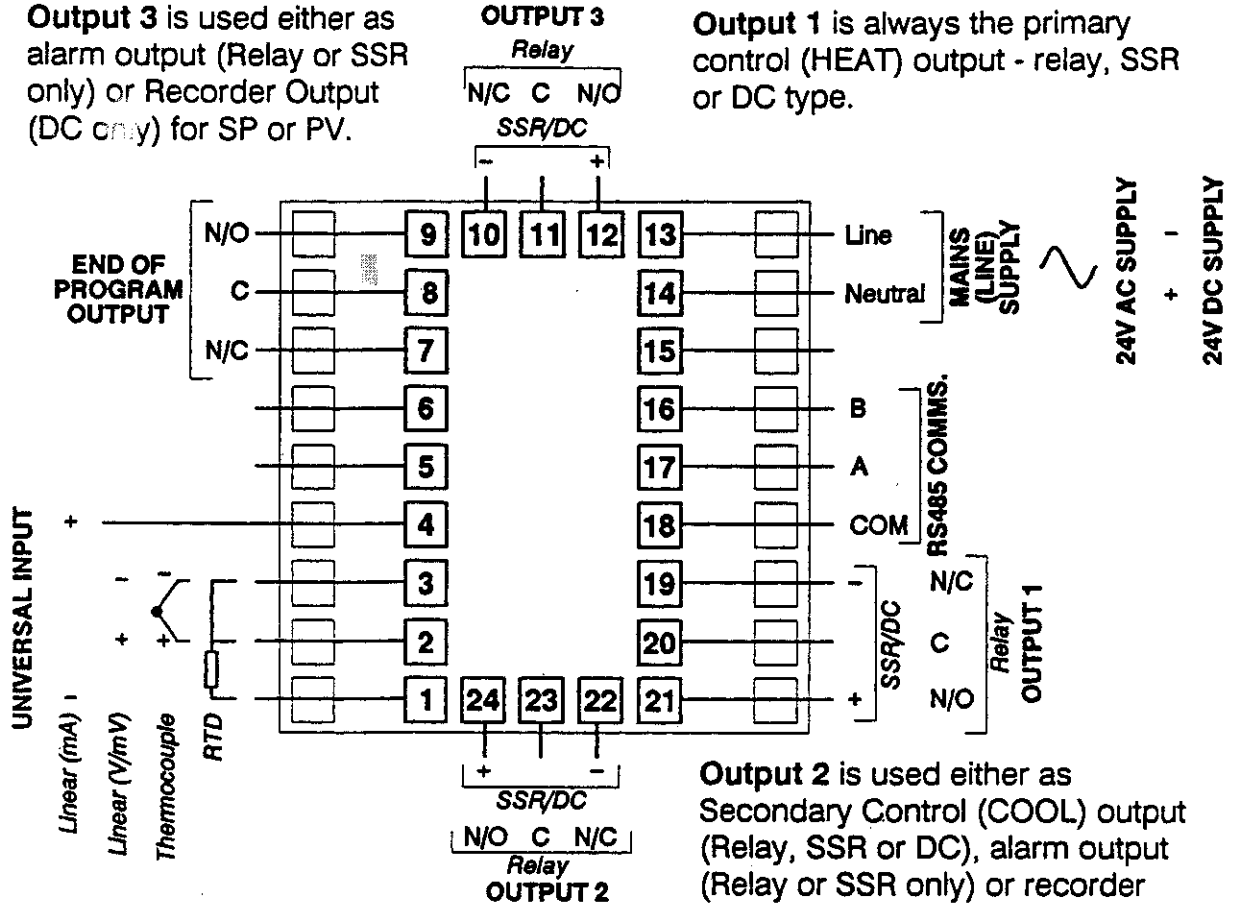

**Figure 2-3 Panel-Mounting the Digital Controller Programmer**

### 2.3 CONNECTIONS AND WIRING

**Output 3** is used either as alarm output (Relay or SSR only) or Recorder Output (DC only) for SP or PV.

**Output 1** is always the primary control (HEAT) output - relay, SSR or DC type.



**Output 2** is used either as Secondary Control (COOL) output (Relay, SSR or DC), alarm output (Relay or SSR only) or recorder

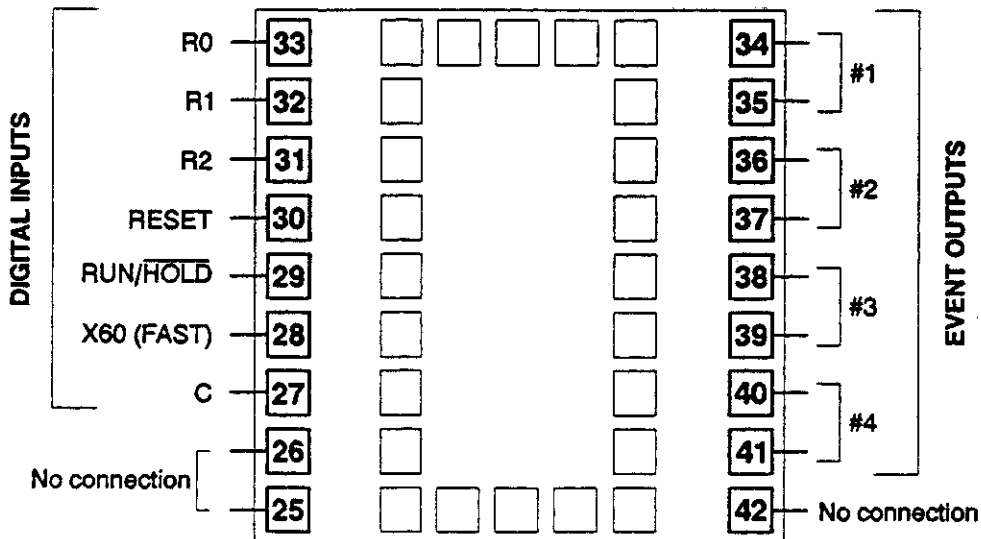

Figure 2-4 Rear Terminal Connections

### 2.3.1 Mains (Line) Input

The Digital Controller Programmer will operate on 96 - 264V AC 50/60Hz mains (line) supply. The power consumption is approximately 4 VA.

#### CAUTION



This equipment is designed for installation in an enclosure which provides adequate protection against electric shock. Local regulations regarding electrical installation should be rigidly observed.

Consideration should be given to prevention of access to the power terminations by unauthorised personnel. Power should be connected via a two-pole isolating switch (preferably situated near the equipment) and a 1A fuse, as shown in Figure 2-5.

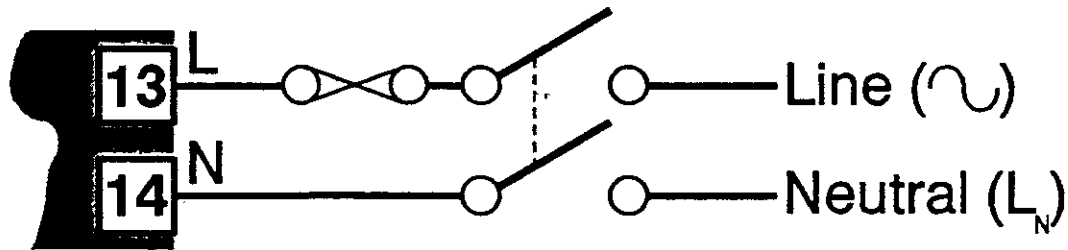

Figure 2-5 Mains (Line) Supply Connections

If the Digital Controller Programmer has relay outputs in which the contacts are to carry mains (line) voltage, it is recommended that the relay contact mains (line) supply should be switched and fused in a similar manner but should be separate from the Digital Controller Programmer mains (line) supply.

### 2.3.2 24V (Nominal) AC/DC Supply

The supply connections for the 24V AC/DC option of the Digital Controller Programmer are as shown in Figure 2-6. Power should be connected via a two-pole isolating switch and a 315mA slow-blow (anti-surge Type T) fuse.

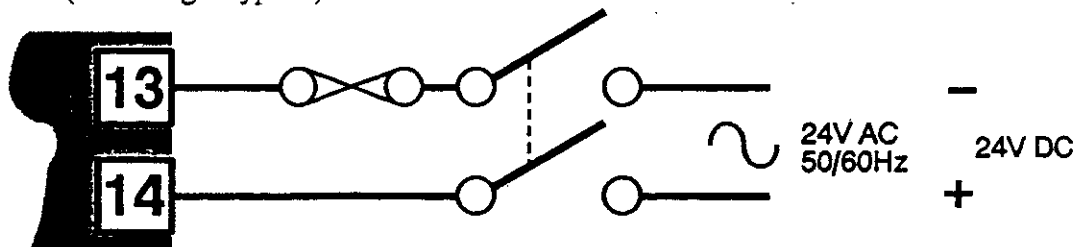

Figure 2-6 24V AC/DC Supply Connections

With the 24V AC/DC supply option fitted, these terminals will accept the following supply voltage ranges:

24V (nominal) AC 50/60Hz -	20 - 50V
24V (nominal) DC -	22 - 65V

Table 2-1 Thermocouple Cable Colour Codes

Thermocouple Type	Cable Material	British				
		(BS1843: 1952)	(BS4937: Part 30: 1993)	American (ASTM)	German (DIN)	French (NFE)
T	Copper Constantan	+ White - Blue * Blue	+ Brown - White * Brown	+ Blue - Red * Blue	+ Red - Brown * Brown	+ Yellow - Blue * Blue
J	Iron/Constantan	+ Yellow - Blue * Black	+ Black - White * Black	+ White - Red * Black	+ Red - Blue * Blue	+ Yellow - Black * Black
K	Nickel Chromium Nickel Aluminium	+ Brown - Blue * Red	+ Green - White * Green	+ Yellow - Red * Yellow	+ Red - Green * Green	+ Yellow - Purple * Yellow
R S	13% Copper 10% Copper Nickel	+ White - Blue * Green	+ Orange - White * Orange	+ Black - Red * Green	+ Red - White * White	+ Yellow - Green * Green
B	Platinum/Rhodium		+ Grey - White * Grey	+ Grey - Red * Grey		

\* Colour of overall sheath.

### 2.3.3 Thermocouple Input

The correct type of thermocouple extension leadwire or compensating cable must be used for the entire distance between the Digital Controller Programmer and the thermocouple, ensuring that the correct polarity is observed throughout. Joints in the cable should be avoided, if possible. The Digital Controller Programmer's CJC facility must be enabled (normal conditions) for this input (see Subsection 4.3).

**NOTE:** Do not run thermocouple cables adjacent to power-carrying conductors. If the wiring is run in a conduit, use a separate conduit for the thermocouple wiring. If the thermocouple is grounded, this must be done at one point only. If the thermocouple extension lead is shielded, the shield must be grounded at one point only.

The colour codes used on thermocouple extension leads are shown in Table 2-1.

### 2.3.4 RTD Inputs

The compensating lead should be connected to Terminal 3. For two-wire RTD inputs, Terminals 2 and 3 should be linked. The extension leads should be of copper and the resistance of the wires connecting the resistance element should not exceed 5 ohms per lead (the leads should be of equal length).

### 2.3.5 Linear Inputs

For linear mA input ranges, connection is made to Terminals 1 and 4 in the polarity shown in Figure 3-4. For linear mV and V ranges, connection is made to Terminals 2 and 3 in the polarity shown in Figure 3-4. For details of the linear input ranges available, refer to Appendix A.

### 2.3.6 Digital Inputs

These inputs will accept TTL, Open Collector or voltage-free (switch) connections. A Digital Input Option PCB must be fitted and the External Option parameter (in Configuration Mode - see Subsection 4.2 of this manual) must be set to **inP** or **both** for these terminals to be operable. The degree of external selection/control is defined by the External Selection parameter in Program Define Mode (see Operator's Manual, Section 8). It is assumed that all external selection/run control functions are enabled for the purposes of this description.

Terminals 31 (R2) to 33 (R0) provide a binary-coded input which is used to select the program:

Digital Inputs = TTL level				Digital Inputs = Contacts (switches)			
Digital Inputs				Digital Inputs			
R0	R1	R2	Program Selected	R0	R1	R2	Program Selected
0	0	0	Program 1	Closed	Open	Open	Program 1
1	0	0	Program 2	Open	Closed	Open	Program 2
0	1	0	Program 3	Closed	Closed	Open	Program 3
1	1	0	Program 4	Open	Open	Closed	Program 4
0	0	1	Program 5	Closed	Open	Closed	Program 5
1	0	1	Program 6	Open	Closed	Closed	Program 6
0	1	1	Program 7	Closed	Closed	Closed	Program 7
1	1	1	Program 8	Open	Open	Open	Program 8

For the Program Control inputs, the following convention has been adopted: for TTL inputs OFF = logic 0, ON = logic 1; for contact (switch) inputs, OFF = open, ON = closed.

Terminal 30 is the Program Abort control. It is edge-sensitive; an OFF-ON transition at any time will cause an immediate Program Abort.

Terminal 29 provides the remote Run Program/Hold Program control and has an identical effect to that of the Run/Hold key on the front panel. An OFF-ON transition will cause the currently-selected program to be run (or to be resumed if it is currently held); An ON-OFF transition will cause the currently-running program to be held. *Powering-up the Digital Controller Programmer with this terminal ON will not cause a program to run.*

Terminal 28 provides the "x60" program timebase selection. This terminal is level-sensitive (ON = minutes/seconds, OFF = hours/minutes). *When the Digital Controller Programmer is powered-up, the initially-selected timebase will be according to the level on this terminal at power-up.*

NOTE: All remote selection/control functions except the Abort function have precedence over the corresponding front panel controls. The "x60" function will also take precedence over any "Pre-set x60" parameter setting (see Operator Manual, Section 8).

### 2.3.7 Relay Outputs

Outputs 1, 2 and 3: contacts rated at 2A resistive at 120/240V AC.

End of Program/Event outputs: contacts rated at 5A resistive at 120/240V AC.

### 2.3.8 SSR Drive Outputs

These outputs produce a time-proportioned non-isolated DC signal (0 - 4.3V nominal, output impedance 250 ohms).

### 2.3.9 DC Outputs

See Appendix B.

### 2.3.10 Event Outputs

These outputs are only available if the Event Output PCB is fitted and if the External Option parameter in Configuration Mode (see Subsection 4.2 of this manual) is set to either **out** or **both**. They are single pole single throw Normally Open relay contacts. For the current segment of the currently-running/held program, these outputs are in the states defined by the Event parameter (see Operator's Manual, Section 8) for that segment. 0 = open, 1 = closed.

### 2.3.11 RS485 Serial Communications Link

The "A" terminal (Terminal 17) on the Digital Controller Programmer should be connected to the "A" terminal on the master device; the "B" terminal (Terminal 16) on the Digital Controller Programmer should be connected to the "B" terminal on the master device. Where several Digital Controller Programmers are connected to one master port, the master port transceiver in the active state should be capable of driving a load of 12k $\Omega$  per Digital Controller Programmer; the master port transceiver in the passive state must have pull-up/pull-down resistors of sufficiently low impedance to ensure that it remains in the quiescent state whilst supplying up to  $\pm 100\mu\text{A}$  each to the Digital Controller Programmer transceivers in the high impedance state.

## SECTION 3 INTERNAL LINKS AND SWITCHES

### 3.1 REMOVING THE DIGITAL CONTROLLER PROGRAMMER FROM ITS HOUSING



**CAUTION:** Before removing the Digital Controller Programmer from its housing, ensure that all power has been removed from the rear terminals.

To withdraw the Digital Controller Programmer from its housing, simply grip the side edges of the front panel (there is a finger grip on each edge) and pull the panel forwards. This will release the Digital Controller Programmer from its rear connectors in the housing and will give access to the PCBs. Take note of the orientation of the Digital Controller Programmer for subsequent replacement into the housing. The positions of the PCBs are shown in Figure 3-1.

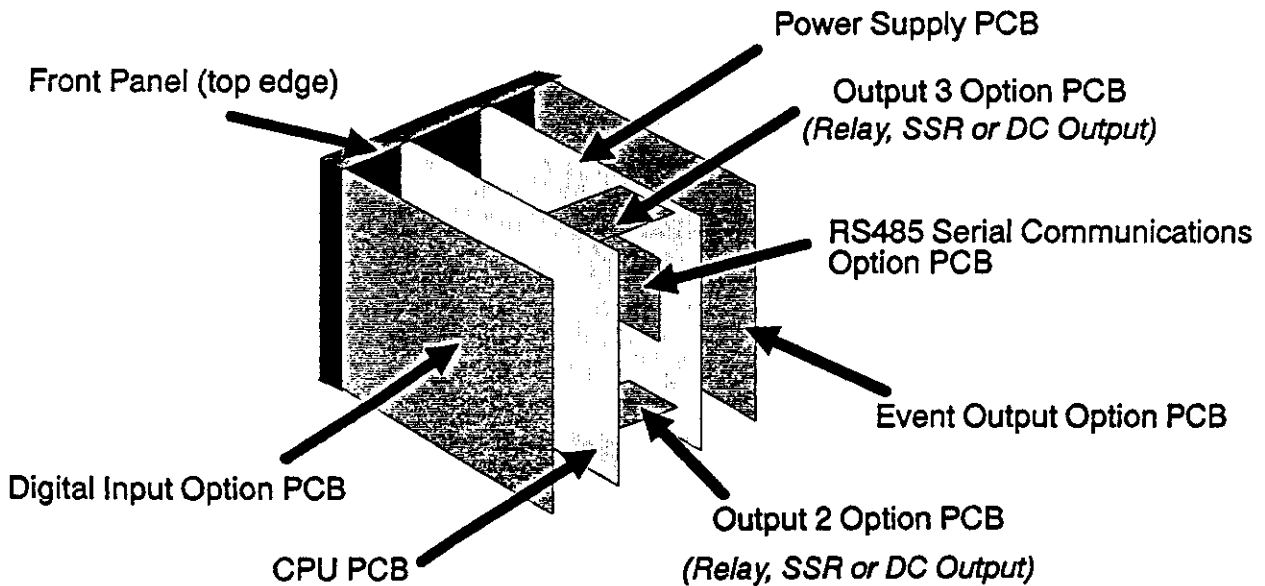

Figure 3-1 PCB Positions



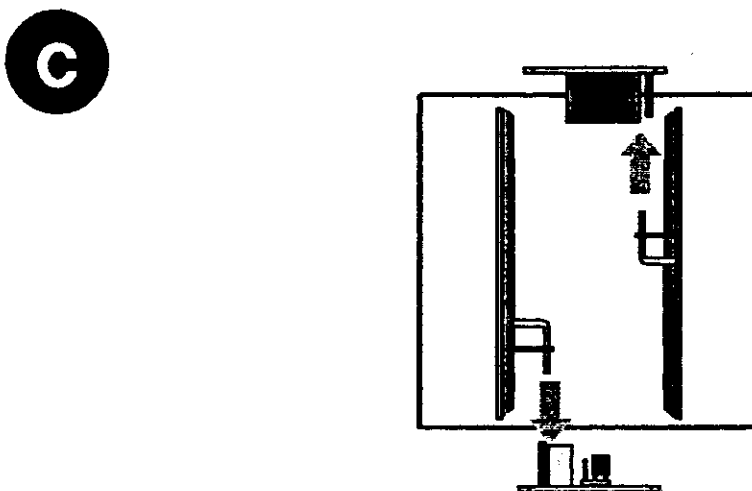
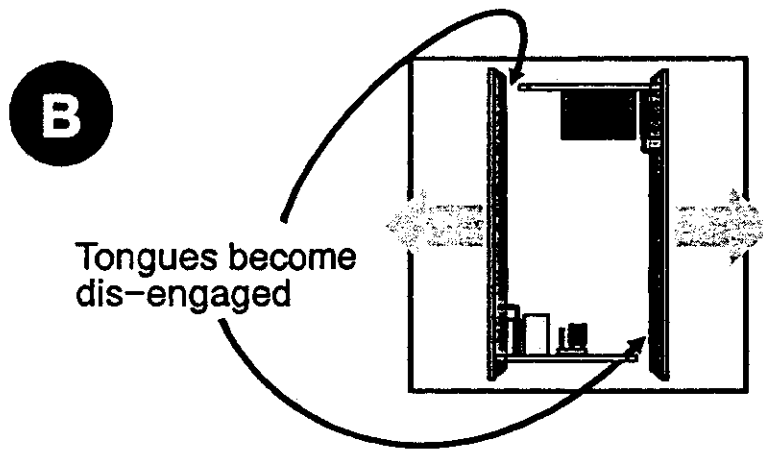
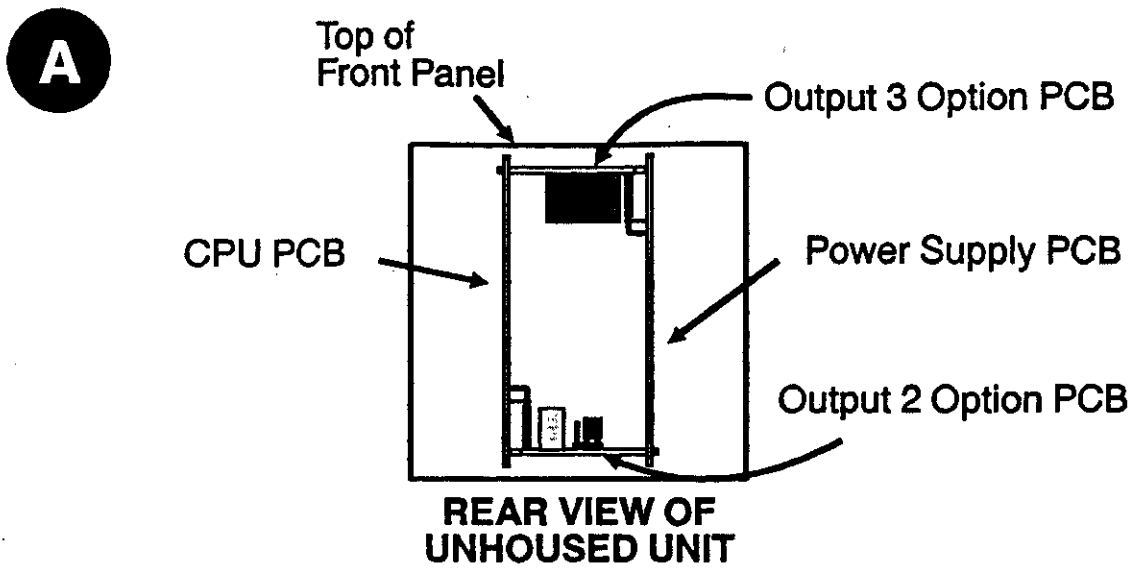

Figure 3-2 Removing the Output 2/Output 3 Option PCBs

### 3.2 REMOVING/REPLACING THE OUTPUT 2/OUTPUT 3 OPTION PCBs

With the Digital Controller Programmer removed from its housing:

1. Gently push the rear ends of the CPU PCB and Power Supply PCB apart slightly, until the two tongues on each of the Output 2/Output 3 Option PCBs become dis-engaged - see Figure 3-2B; The Output 2 Option PCB tongues engage in holes in the Power Supply PCB and the Output 3 Option PCB tongues engage in holes on the CPU PCB.
2. Carefully pull the required Option PCB (Output 2 or Output 3) from its connector (Output 2 Option PCB is connected to the CPU PCB and Output 3 Option PCB is connected to the Power Supply PCB) - see Figure 3-2C. Note the orientation of the PCB in preparation for its replacement.

Adjustments may now be made to the link jumpers on the CPU PCB, the Output 2/Output 3 Option PCBs (if DC output) and (if fitted) the DC Output 1 PCB. The replacement procedure is a simple reversal of the removal procedure.

### 3.3 REMOVING/REPLACING THE RS485 COMMUNICATIONS OPTION PCB

The RS485 Communications Option PCB is mounted on the inner surface of the Power Supply PCB and can be removed when the Digital Controller Programmer is removed from its housing (see Subsection 7.1) Figure 3-3 illustrates the removal/replacement procedure. *It is not necessary to remove the Output 2/Output 3 Option PCBs to perform this procedure.*



Figure 3-3 Removing/Replacing the RS485 Communications Option PCB

### 3.4 INSTALLING/REMOVING THE DIGITAL INPUT OPTION PCB

The location of the Digital Input Option PCB is shown in Figure 3-4. It is connected to the CPU PCB via a flexi-strip connector, as shown.

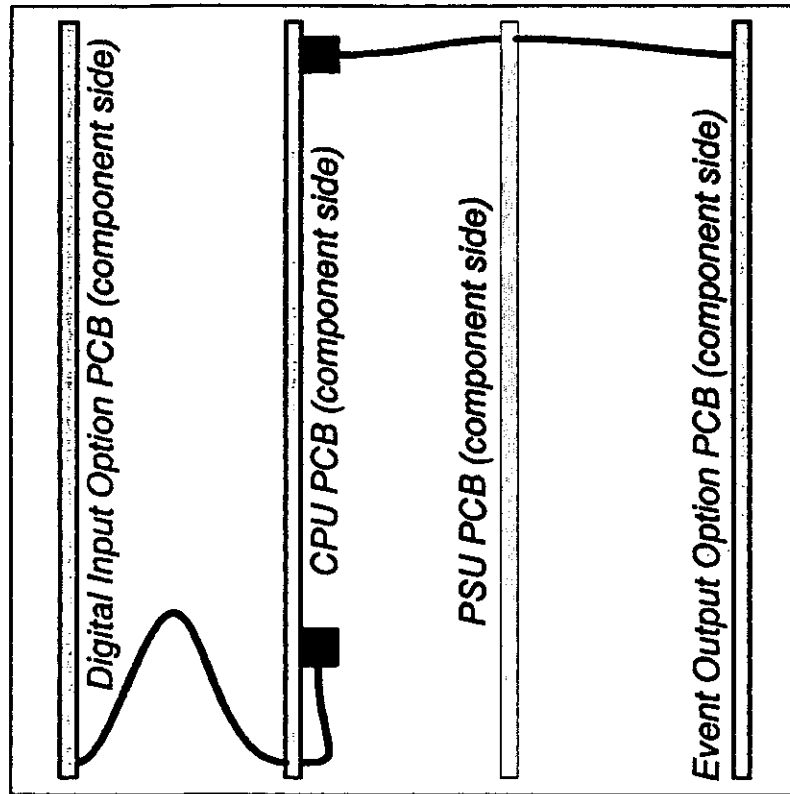

REAR VIEW OF UNHOUSED INSTRUMENT

Figure 3-4 Location of Digital Input Option PCB and Event Output Option PCB

To install the Digital Input Option PCB:

1. Hold the PCB approximately in position and carefully insert the free end of the flexi-strip cable into the socket near the bottom edge of the CPU PCB (ensuring that none of the pins on the end of the flexi-strip become bent and that the flexi-strip is not twisted).
2. Fully insert the Digital Input Option PCB into its connector at the rear of the front panel (when the PCB is fully inserted, it will become engaged in the slots above and below its connector).

To remove the Digital Input Option PCB:

1. Dis-engage the PCB from its slots (above and below the connector at the rear of the front panel) and withdraw the PCB clear of the connector.
2. Disconnect the flexi-strip from the connector near the bottom edge of the CPU PCB.
3. Remove the Digital Input Option PCB completely from the instrument.

### 3.5 INSTALLING/REMOVING THE EVENT OUTPUT OPTION PCB

The location of the Event Output Option PCB is shown in Figure 3-4. It is connected to the CPU PCB via a flexi-strip connector, as shown.

To install the Event Output Option PCB:

1. Hold the PCB approximately in position and carefully insert the free end of the flexi-strip cable into the socket near the top edge of the CPU PCB (ensuring that none of the pins on the end of the flexi-strip become bent and that the flexi-strip is not twisted).
2. Fully insert the Event Output Option PCB into its connector at the rear of the front panel (when the PCB is fully inserted, it will become engaged in the slots above and below its connector).

To remove the Event Output Option PCB:

1. Dis-engage the PCB from its slots (above and below the connector at the rear of the front panel) and withdraw the PCB clear of the connector.
2. Disconnect the flexi-strip from the connector near the top edge of the CPU PCB.
3. Remove the Event Output Option PCB completely from the instrument.

### 3.6 REPLACING THE DIGITAL CONTROLLER PROGRAMMER IN ITS HOUSING

To replace the Digital Controller Programmer, simply align the CPU PCB and Power Supply PCB with their guides and connectors in the housing and slowly but firmly push the Digital Controller Programmer into position.

#### CAUTION

Ensure that the instrument is correctly orientated. A stop will operate if an attempt is made to insert the instrument in the wrong orientation (e.g. upside-down). *This stop must not be over-ridden.*

### 3.7 SELECTION OF INPUT TYPE

The selection of input type is accomplished on link jumpers LJ1/LJ2/LJ3 on the CPU PCB (see Figure 3-5 and Table 3-1).

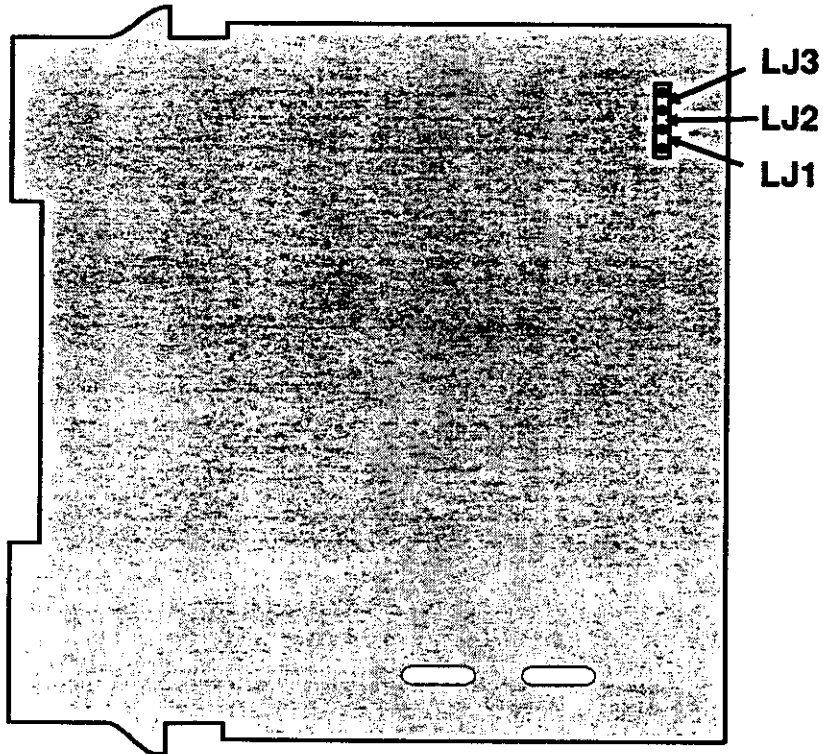

Figure 3-5 CPU PCB (Relay/SSR Output 1)

Table 3-1 Input Type Selection

Code	Input Type	CPU PCB Link Jumper Fitted
DCP101	RTD or DC (mV)	None (Parked)
DCP102	Thermocouple	LJ3
DCP103	DC (mA)	LJ2
DCP104	DC (V)	LJ1

### 3.8 SELECTION OF PRIMARY OUTPUT (OUTPUT 1) TYPE

The required type of Output 1 is selected by Link Jumpers LJ4/LJ5/LJ6/LJ7/LJ8/LJ9 on the Relay/SSR Output 1 CPU PCB (see Figure 3-6 and Table 3-2).

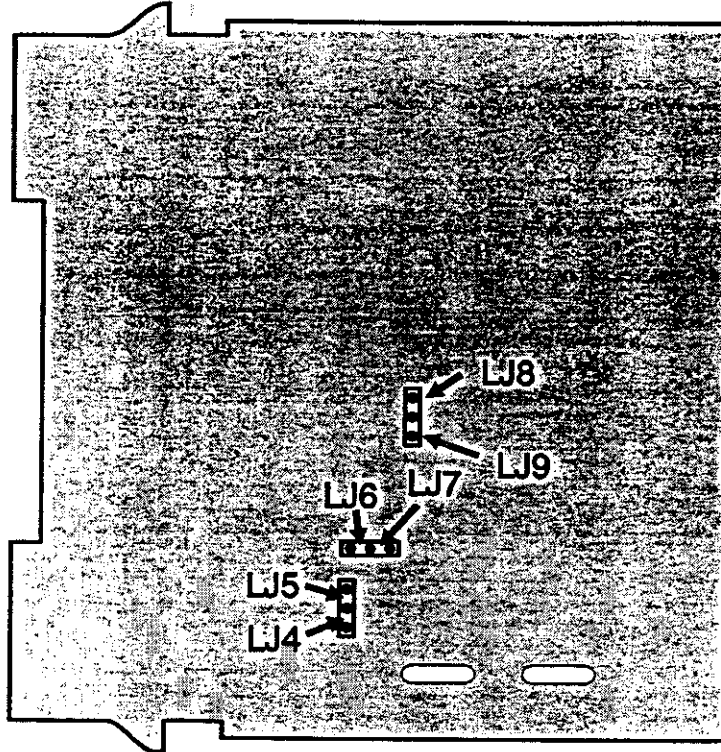

Figure 3-6 PSU PCB Link Jumpers

Table 3-2 Output 1 Type Selection

Code	Output Type	Link Jumpers Fitted
DCP10x-1	Relay	LJ5 and LJ6
DCP10x-2	DC for SSR	LJ4 and LJ7
DCP10x-3	DC (0 - 10V)	LJ8
DCP10x-4	DC (0 - 20mA)	LJ9
DCP10x-5	DC (0 - 5V)	LJ8
DCP10x-7	DC (4 - 20mA)	LJ9

### 3.9 OUTPUT 2 TYPE/OUTPUT 3 TYPE

The type of output for Output 2 and Output 3 is determined by the Option PCB fitted in the appropriate position (see Figure 3-1) and, in the case of the DC Output Option PCB being fitted, the setting of Link Jumpers LJ8 and LJ9 on that Option PCB (see Figure 3-7 and Table 3-3). There are three types of option PCB which may be used for Output 2 and Output 3:

1. Relay Output Option PCB (no link jumpers)
2. SSR Output Option PCB (no link jumpers)
3. DC Output Option PCB (link jumpers as shown in Figure 3-7)

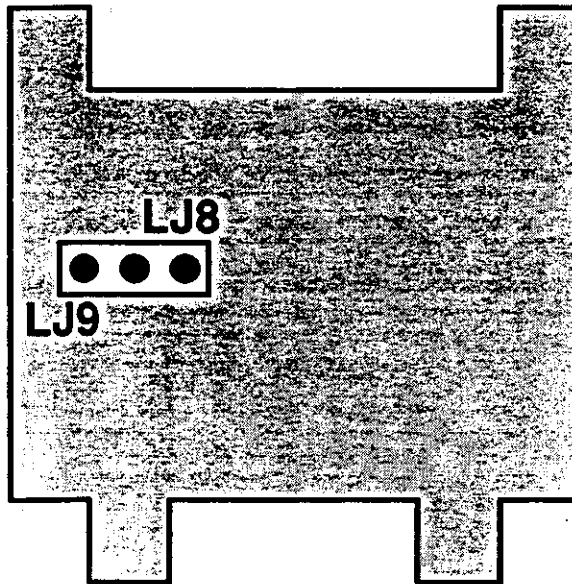

Figure 3-7 DC Output Option PCB (Output 2/Output 3)

Table 3-3 Output 2/Output 3 Type Selection

Code	Output Type	Link Jumpers Fitted
DCP10x-x-3	DC (0 - 10V)	LJ8 (DC Output 2 Option PCB)
DCP10x-x-4	DC (0 - 20mA)	LJ9 (DC Output 2 Option PCB)
DCP10x-x-5	DC (0 - 5V)	LJ8 (DC Output 2 Option PCB)
DCP10x-x-7	DC (4 - 20mA)	LJ9 (DC Output 2 Option PCB)
DCP10x-x-x-3	DC (0 - 10V)	LJ8 (DC Output 3 Option PCB)
DCP10x-x-x-4	DC (0 - 20mA)	LJ9 (DC Output 3 Option PCB)
DCP10x-x-x-5	DC (0 - 5V)	LJ8 (DC Output 3 Option PCB)
DCP10x-x-x-7	DC (4 - 20mA)	LJ9 (DC Output 3 Option PCB)

## SECTION 4 CONFIGURATION MODE

### 4.1 ENTRY INTO CONFIGURATION MODE

To enter Configuration Mode:

1. Ensure that the Digital Controller Programmer is powered-down.
2. Power-up the Digital Controller Programmer and, within 30 seconds of power-up, hold down the Up and **SET UP** keys simultaneously for approximately 4 to 8 seconds.

NOTE: This must be the first key action after power-up.

The Digital Controller Programmer will then enter Configuration Mode, whereupon the upper and lower main displays will initially be of the form:



A digital display showing the word 'CONF' in the upper half and the number '1419' in the lower half.

showing the current input code selected, and the Message Display will show:



A message display showing the word 'Input' in a stylized font.

The user may then step through the Configuration Mode parameters using the **SET UP** key. For each parameter, the Message Display will show a legend identifying that parameter and the lower main display will show the current parameter setting. The setting may be adjusted using the Up/Down keys. As soon as the setting is changed, the lower main display will flash, indicating that the new setting has yet to be confirmed. When the setting is as required, it may be confirmed by pressing the **MODE** key, whereupon the upper display will become static.

NOTE: Changes to the setting of certain Configuration Mode parameters (e.g. input range, output use and type) will cause the Program Define Mode and Controller Define Mode parameters to be automatically set to their default values.

### 4.2 HARDWARE DEFINITION CODE

This parameter is a special facility in Configuration Mode, which is used to specify the hardware fitted (input type, output types etc.); this must be compatible with the hardware actually fitted. It can be accessed, with the Digital Controller Programmer in Configuration Mode, by simultaneously pressing the Down and **SET UP** keys. The Message Display will then show:



A message display showing the word 'HwDefine' in a stylized font.



and the lower main display will be of the form:

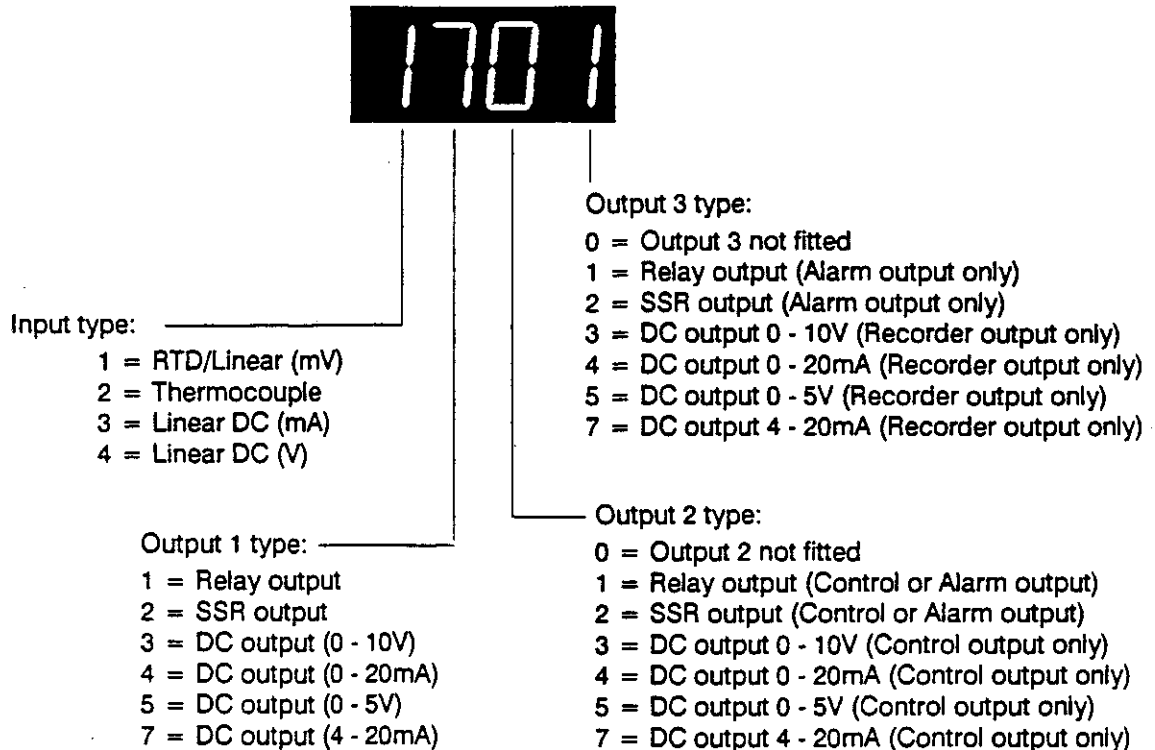

The displayed code may be incremented/decremented using the Up/Down keys as required. The maximum setting available for this code is 4777. For example, the code for a thermocouple input, DC 4 - 20mA primary output (Output 1) and relay Output 3 would be 2701. When the code is first altered, the code display will flash, until the desired value is displayed and confirmed by pressing the **MODE** key.

**NOTE:** It is essential that this code is changed promptly whenever there is a change to the Digital Controller Programmer's hardware configuration (change of input/output type, alarm/recorder output added/removed etc.). The Digital Controller Programmer software depends upon this code to operate correctly.

Hardware Definitions may be viewed as Read Only displays in Base Mode by pressing the **SET UP** and Down keys simultaneously.

Whilst the Hardware Definition Code is displayed, pressing the **SET UP** key will cause the Message Display to change to:



and the lower main display to change to one of:

No option PCB fitted

Digital Input Option PCB fitted

Event Output Option PCB fitted

Both option PCBs fitted

The desired setting can be achieved using the Up/Down keys. Pressing the **SET UP** key will change the Message Display to:

and the lower main display to one of:

RS485 Communications Option PCB not fitted

RS485 Communications Option PCB fitted - unit acting as slave device

RS485 Communications Option PCB fitted - unit acting as master device

The desired setting can be achieved using the Up/Down keys. If the External Option parameter has not been set to **inP** or **both**, pressing the **SET UP** key will return to the initial External Option parameter display. If the External Option parameter has been set to either **inP** or **both**, pressing the **SET UP** key will change the Message Display to:

and the lower main display to one of:

Digital Inputs = TTL level

Digital Inputs = Contacts (switches)

#### Digital Inputs

R0	R1	R2	Program Selected
0	0	0	Program 1
1	0	0	Program 2
0	1	0	Program 3
1	1	0	Program 4
0	0	1	Program 5
1	0	1	Program 6
0	1	1	Program 7
1	1	1	Program 8

#### Digital Inputs

R0	R1	R2	Program Selected
Closed	Open	Open	Program 1
Open	Closed	Open	Program 2
Closed	Closed	Open	Program 3
Open	Open	Closed	Program 4
Closed	Open	Closed	Program 5
Open	Closed	Closed	Program 6
Closed	Closed	Closed	Program 7
Open	Open	Open	Program 8

The desired setting can be achieved using the Up/Down keys. Pressing the **SET UP** key will then return to the initial External Option parameter display. To exit from the Hardware Definition Code facility, press the Down and **SET UP** keys simultaneously (which will cause a return to the normal Configuration Mode). Alternatively, either of the methods of exit from Configuration Mode (see Subsection 4.5) may be used here.

### 4.3 CONFIGURATION MODE PARAMETERS

The Configuration Mode parameters are presented for view/edit in the following sequence:

Parameter	Message Display	Function	Available Settings/Values (Lower Main Display)
Primary Input Range <sup>5</sup>	<b>InpuT</b>	Code displayed defines input type/range (see Appendix A)	See Appendix A
Control Action	<b>Control</b>	Specifies control action of Output 1 <sup>1</sup>	<b>dir</b> Direct-acting * <b>rEv</b> Reverse-acting
Alarm 1 Type	<b>Alarm 1</b>	Specifies Alarm 1 operation	<b>P_hI</b> Process High * <b>P_Lo</b> Process Low <b>dE</b> Deviation <b>bAnd</b> Band <b>nonE</b> None
Alarm 2 Type	<b>Alarm 2</b>	Specifies Alarm 2 operation	<b>P_hI</b> Process High <b>P_Lo</b> Process Low * <b>dE</b> Deviation <b>bAnd</b> Band <b>nonE</b> None
Alarm Inhibit	<b>Inhibit</b>	Specifies which alarms are inhibited	<b>nonE</b> No inhibit * <b>ALA1</b> Alarm 1 <b>ALA2</b> Alarm 2 <b>both</b> Both Alarms

\* Default value/setting

*Continued overleaf.....*

Parameter	Message Display	Function	Available Settings/Values (Lower Main Display)
Output 2 Usage	Out2 Use	Specifies use of Output 2 <sup>2</sup>	out2 Control Output <sup>1</sup> A2_d Alarm 2 (direct) A2_r Alarm 2 (reverse) Or_d Alarm 1 OR 2 (direct) Or_r Alarm 1 OR 2 (reverse) Ad_d Alarm 1 AND 2 (direct) Ad_r Alarm 1 AND 2 (reverse) LP_d Loop Alarm (direct) LP_r Loop Alarm (reverse)
Output 3 Usage	Out3 Use	Specifies use of Output 3 <sup>3</sup>	A1_d Alarm 1 (direct) A1_r Alarm 1 (reverse) Or_d Alarm 1 OR 2 (direct) Or_r Alarm 1 OR 2 (reverse) Ad_d Alarm 1 AND 2 (direct) Ad_r Alarm 1 AND 2 (reverse) LP_d Loop Alarm (direct) LP_r Loop Alarm (reverse) rEcS Recorder Output (SP) rEcP Recorder Output (PV)
Segment Mode	Seg Mode	Defines parameter used to specify duration of each segment (along with final SP value)	T, Time * rA Ramp Rate **
Baud Rate <sup>6</sup>	BaudRate	Selects Baud Rate for RS485 Comms.	Numeric value: 1200,2400, 4800 or 9600
Address <sup>6,7</sup>	Address	Selects RS485 comms. address	Numeric value in range 1 - 32
CJC <sup>4</sup> Enable/Disable	CJC	Enables/disables cold junction compensation	EnAb Enabled * d,SA Disabled

\* Default value/setting

Continued overleaf.....

\*\* When x60 = OFF, Time = hours/minutes and Ramp Rate = LSD/hour  
 When x60 = ON, Time = minutes/seconds and Ramp Rate = LSD/minute

Parameter	Message Display	Function	Available Settings/Values (Lower Main Display)
Lock Code	LockCode	Displays current lock code value	Read Only - no adjustment in Configuration Mode - see Operator's Manual.

### NOTES ON CONFIGURATION MODE PARAMETERS

1. If the secondary output is chosen as Output 2 (COOL) control output, its action is always the complement of the action of Output 1.
2. The default setting for Output 2 Usage is Alarm 2 hardware output, direct-acting (if relay/SSR output) or Output 2 - COOL (if DC output).
3. The default setting for Output 3 Usage is Alarm 1 hardware output, direct-acting (if relay/SSR output) or Process Variable Recorder Output (if DC output).
4. This parameter does not appear in the sequence if the input type selected is not thermocouple (see Subsection 4.2). If the CJC facility is disabled, the initial display in Operator Mode will show horizontal bars flashing in the lower display.
5. The primary input range default setting is dependent upon the hardware fitted, as indicated in the Hardware Definition Code (see Subsection 4.2):

Input Hardware Fitted	Default Setting
Thermocouple	1419 (Type "J", 0 to 760°C)
RTD/Linear (mV)	7220 (RTD Pt100 0 to 800°C)
Linear (mA)	3414 (4 to 20mA)
Linear (V)	4446 (0 to 10V)

6. These parameters do not appear if the Hardware Definition Comms parameter is set to nonE.
7. This parameter does not appear if the Communications Option is set to operate in Master Mode (see Subsection 4.2)

#### 4.4 ALARM INHIBIT FACILITY

On power-up, an "alarm" condition may occur, based on the alarm value, the process variable value and, if appropriate to the alarm type, the setpoint value. This would normally activate an alarm; however, if the pertinent alarm is inhibited, the alarm indication is suppressed and the alarm will remain inactive. This will prevail until the "alarm" condition returns to the "inactive" state, whereafter the alarm will operate normally.

#### 4.5 EXIT FROM CONFIGURATION MODE

To leave Configuration Mode, depress the Up and **SET UP** keys simultaneously.

**NOTE:** An automatic exit to Base Mode will be made if, in Configuration Mode, there is no front panel key activity for five minutes.

The exit is made via the power-up self-test routines which include a lamp test.

## **SECTION 5**

### **RS485 SERIAL COMMUNICATIONS**

The DCP 100 Digital Controller Programmer may be equipped with a three-wire RS485-compatible serial communications facility, by which means communication may occur between the Digital Controller Programmer and a master device (e.g. a computer or terminal) or up to 32 slave devices.

#### **5.1 RS485 CONNECTIONS**

The connections for Digital Controller Programmers equipped with the serial communications option are shown in Section 2. Communication is at a user-selectable rate from the range 1200, 2400, 4800 and 9600 Baud and the cable used should be suitable for data transfer at the selected rate over the required distance. Transmitters/receivers conform to the recommendations in the EIA Standard RS485.

#### **5.2 COMMUNICATIONS ENABLE/DISABLE**

When Communications are enabled (in Controller Define Mode - see Operators' Manual), the Digital Controller Programmer parameters may be adjusted by the master device via the serial communications link. If communications are disabled, the Digital Controller Programmer will not adjust or change any parameters in response to commands received from the master device and will send a negative acknowledgement in response to such commands. Whether communications are enabled or disabled, the Digital Controller Programmer will return the requested information in response to a Type 2 Interrogation message (see Subsection 5.4.2) from the master device.

#### **5.3 SELECTION OF COMMUNICATIONS CHANNEL ADDRESS**

The address for each Digital Controller Programmer is defined in Configuration Mode (see Subsection 4.3.9). Up to 32 Digital Controller Programmers, each with a unique address, may be connected to the master device.

#### **5.4 COMMUNICATIONS PROTOCOL**

The protocol assumes half duplex communications. All communication is initiated by the master device. The master sends a command or query to the addressed slave and the slave replies with an acknowledgement of the command or the reply to the query. All messages, in either direction, comprise:

- (a) A Start of Message character
  - R (Programmer Parameters) or L (Controller Parameters)
- (b) One or two address characters (uniquely defining the slave)
- (c) A parameter/data character string {DATA}
- (d) An End of Message character

Messages from the master device may be one of five types:

- Type 1:** {S} {N} ?? \*
- Type 2:** {S} {N} {P} {C} \* or R {N} {P} {C} \*
- Type 3:** {S} {N} {P} # {DATA} \* or R {N} {P} # {DATA} \*
- Type 4:** {S} {N} {P} I \* or R {N} {P} I \*
- Type 5:** {S} {N} \ P S S ? \*

where all characters are in ASCII code and:

- {S} is the Start of Message character L (Hex 4C) or R (Hex 52). L is used for Controller parameters; R is used for Programmer parameters.
- {N} is the slave Digital Controller Programmer address (in the range 1 - 32); addresses 1 - 9 may be represented by a single digit (e.g. 7) or in two-digit form, the first digit being zero (e.g. 07).
- {P} is a character which identifies the parameter to be interrogated/modified - see Table 5-2 and Table 5-3.
- {C} is the command (see below)
- # indicates that {DATA} is to follow (Hex 23)
- {DATA} is a string of numerical data in ASCII code (see Table 5-1)
- P is the Program Number
- S S is the Segment Number (01 to 16)
- \* is the End of Message character (Hex 2A)

No space characters are permitted in messages. Any syntax errors in a received message will cause the slave controller to issue no reply and await the Start of Message character.

**Table 5-1 {DATA} Element - Sign/Decimal Point Position**  
**{DATA} Content Sign/Decimal Point Position**

abcd0	+ abcd
abcd1	+ abc.d
abcd2	+ ab.cd
abcd3	+ a.bcd
abcd5	-abcd
abcd6	-abc.d
abcd7	-ab.cd
abcd8	-a.bcd

#### 5.4.1 Type 1 Message

L {N} ?? \*

This message is used by the master device to determine whether the addressed slave Digital Controller Programmer is active. The reply from an active slave Digital Controller Programmer is

L {N} ? A \*

An inactive Digital Controller Programmer will give no reply.

#### 5.4.2 Type 2 Message

L {N} {P} {C} \* or R {N} {P} {C} \*

This type of message is used by the master device to interrogate or modify a parameter in the addressed Digital Controller Programmer. {P} identifies the parameter (as defined in Table 5-2) and {C} represents the command to be executed, which may be one of the following:

- + (Hex 2B) - Increment the value of the parameter defined by {P}
- (Hex 2D) - Decrement the value of the parameter defined by {P}
- ? (Hex 3F) - Determine the current value of the parameter defined by {P}

The reply from the addressed Digital Controller Programmer is of the form:

L {N} {P} {DATA} A \* or R {N} {P} {DATA} A \*

where {DATA} comprises five ASCII-coded digits whose format is shown in Table 5-1. The data is the value requested in a query message or the new value of the parameter after modification. If the action requested by the message from the master device would result in an invalid value for that parameter (either because the requested new value would be outside the permitted range for that parameter or because the parameter is not modifiable), the Digital Controller Programmer replies with a negative acknowledgement:

L {N} {P} {DATA} N \* or R {N} {P} {DATA} N \*

The {DATA} string in the negative acknowledgement reply will be indeterminate. If the process variable or the deviation is interrogated whilst the process variable is outside the range of the Digital Controller Programmer, the reply is:

L {N} {P} < ?? > 0 A \*

if the process variable is over-range, or

L {N} {P} < ?? > 5 A \*

if the process variable is under-range.

#### Scan Tables

A parameter identifier character "]" in the message from the master device indicates that a "Scan Table" operation is required. This provides a facility for interrogating the values of a group of parameters and status in a single message from the master device. The reply to such a command would be in the form:



L {N} ] xx aaaaa bbbbb ccccc ddddd eeeee A \*

for Controller Scan Table, or

R {N} ] 25 P ss VVVV TTTT CCCC SSSS EEEE A \*

for a Program Scan Table. For the Controller Scan Table response, xx is the number of data digits to follow; this is 20 for a single-control-output instrument and 25 for a dual-control-output instrument. For further information, refer to Subsections 5.11 and 5.14.

#### 5.4.3 Type 3 Message

L {N} {P} # {DATA} \* or R {N} {P} # {DATA} \*

This message type is used by the master device to set a parameter to the value specified in {DATA}. The command is not implemented immediately by the slave Digital Controller Programmer; the slave will receive this command and will then wait for a Type 4 message (see below). Upon receipt of a Type 3 message, if the {DATA} content and the specified parameter are valid, the slave Digital Controller Programmer reply is of the form:

L {N} {P} {DATA} I \* or R {N} {P} {DATA} I \*

(where I = Hex 49) indicating that the Digital Controller Programmer is ready to implement the command. If the parameter specified is invalid or is not modifiable or if the desired value is outside the permitted range for that parameter, the Digital Controller Programmer replies with a negative acknowledgement in the form:

L {N} {P} {DATA} N \* or R {N} {P} {DATA} N \*

#### 5.4.4 Type 4 Message

L {N} {P} I \* or R {N} {P} I \*

This type of message is sent by the master device to the addressed slave Digital Controller Programmer following a successful Type 3 transaction with the same slave Digital Controller Programmer. Provided that the {DATA} content and the parameter specified in the preceding Type 3 message are still valid, the slave Digital Controller Programmer will then set the parameter to the desired value and will reply in the form:

L {N} {P} {DATA} A \*

or

R {N} {P} {DATA} A \*

where {DATA} is the new value of the parameter. If the new value or parameter specified is invalid, the slave Digital Controller Programmer will reply with a negative acknowledgement in the form:

L {N} {P} {DATA} N \*

or

R {N} {P} {DATA} N \*

where {DATA} is indeterminate. If the immediately-preceding message received by the slave Digital Controller Programmer was not a Type 3 message, the Type 4 message is ignored.

### 5.5 PROGRAMMER PARAMETERS (Start of Message character = R)

The Programmer Parameters and their identifier characters are listed in Table 5-2 and their functions are shown in Table 5-3.

Unless otherwise stated, the {DATA} element will follow the standard five-digit format and the decimal point position must be correct for the new value to be accepted and for modification to occur.

**Table 5-2 Programmer Parameters and Identifiers**

Identifier	Parameter/Command	Comments	Type
A	Segment Number	Selects segment in selected program	Read/Write
B	Final Setpoint Value	In selected segment	Read/Write
C	Segment Time/Ramp Rate	In selected segment	Read/Write
G	Number of Cycles Programmed	For selected program	Read/Write
H	Number of Cycles Completed	For selected program	Read Only
I	Current Segment Number	In currently running/held program	Read Only
J	Segment Time Remaining	In currently-running segment	Read Only
K	Programmer Commands	Program control/selection	Write Only
L	Programmer Status 1	Summary of programmer parameters	Read Only
M	Current Setpoint Value	In currently-running/held program	Read Only
N	Current Segment Event Status	Status of each of four Events	Read/Only
P	Current Program Number	Indicates program currently running/held	Read Only
Q	Delay	Defines delay to start of all programs	Read/Write
R	Preset x60 Mode	ON, OFF or not selected (for selected program only)	Read/Write
S	Power Failure Recovery	Selects Cold Start or Warm Start recovery	Read/Write
T	Program Number	Selects program for comms operations	Read/Write
U	User Program Tags	Defines tag name for a program	Read/Write
V	Hold Band Value	In selected program	Read/Write
W	Hold Time Value	Time in manual hold	Read Only
X	Auto-Hold Type	Selects Auto-Hold operation	Read/Write
Y	Hold On	Ramps only, Dwells-only or both	Read/Write
[	External Selection Control	Enables/disables external program selection and/or Run/Hold/Abort control	Read/Write
\	Segment Definitions	Reads/defines details of stated program/segment	Read/Write
]	Program Scan Table	Reads summary of stated program/segment	Read Only
~	Segment Mode	Time Mode or Rate Mode	Read/Write
⌘	Programmer Status 2	Summary of programmer parameters	Read Only

**Table 5-3 Programmer Parameters - Functions**

Parameter	Five-digit {DATA} Element		Dependent Upon:
	Adjustment Range	Decimal Point Position	
Segment Number	0001 to 0016	0	Program Number
Final Setpoint Value	Input Range Min. - Input Range Max.	As per input	Program Number Segment Number
Segment Time/ Ramp Rate	<b>Time Mode:</b> 0000 - 9959 (2 right-most digits must not exceed 59) <b>Rate Mode:</b> 0000 - 9999 000n - Join to Program n (n = 1 to 8), 0009 - Repeat segment, 0010 - End segment	2  As per input 5 5 5	Program Number Segment Number
Number of Cycles Programmed	0000 (infinite) - 9999	0	Program Number
Number of Cycles Completed	Read Only; value range 0000 - 9999 and <HH>0 (numeric limit exceeded)	0	Current Program Number
Current Segment Number	Read Only; value range 0001 - 0016	0	Current Program Number
Segment Time Remaining	Read Only; value range 0000 - 9959 (2 right-most digits must not exceed 59) and <HH>2 (numeric limit exceeded)	2	Current Program Number Current Segment Number
Programmer Commands	Write Only; value range 0001 - 0013, 0021 - 0028 (see Subsection 5.6)	0	-
Programmer Status 1	Read Only (see Subsection 5.7)	N/A	-
Current Setpoint Value	Read Only	As per input	-
Current Segment Event Status	Read Only (see Subsection 5.8)	N/A	Current Segment Number Current Program Number
Current Program Number	Read Only; value range 0001 - 0008	0	-
Delay (all programs)	0000 - 9959 (2 right-most digits must not exceed 59)	2	-
Preset x60 Mode	0000 = No preset state 0001 = Preset x60 ON 0002 = Preset x60 OFF	0	Program Number
Power Fail Recovery	0000 = Cold Start 0001 = Warm Start (see Subsection 5.9)	0	-
Program Number	0001 - 0008	0	-
User Tag Names	See Subsection 5.14	-	Program Number
Guaranteed Soak Band	0000 - input span	As per input	Program Number

Table 5-3 (cont.) Programmer Parameters - Functions

Parameter	Five-digit {DATA} Element		Dependent Upon:
	Adjustment Range	Decimal Point Position	
Hold Time	Read Only: value range 0000 - 9959 (2 right-most digits must not exceed 59) and <HH> 2 (numeric limit exceeded)	2	Current Program Number
Guaranteed Soak Type	0000 = OFF 0001 = only on PV above SP 0002 = only on PV below SP 0003 = on both	0	Program Number
Hold On	0000 = ramps and dwells 0001 = ramps only 0002 = dwells only	0	Program Number
External Selection Control (all programs)	0000 = disabled 0001 = program selection only 0002 = Run/Hold/Abort control only 0003 = both	0	-
Program/Segment Definitions	See Subsection 5.10	See Subsection 5.10	-
Program Scan Table	Read Only (see Subsection 5.11)	See Subsection 5.11	-
Segment Mode	0000 = Time 0001 = Rate	0	-
Programmer Status 2	Read Only (see Subsection 5.13)	N/A	-

## 5.6 PROGRAMMER COMMANDS

{P} = K

This Write Only parameter is used to convey commands to be implemented by the Digital Controller Programmer. In the {DATA} element, the decimal point position digit is set to 0; the remaining four digits are used to specify the command to be executed:

Value	Command	Value	Command
0001	Run currently-selected program <sup>1, 2</sup>	0011	Disable x60 Mode
0002	Manually Hold currently-running program <sup>1</sup>	0012	Enable Program Lock
0003	Release Manual Hold <sup>1</sup>	0013	Disable Program Lock
0004	Jump forward one segment <sup>2</sup>	0021	Run Program 1 <sup>1, 2, 3</sup>
0005	Abort currently-running program <sup>1</sup>	0022	Run Program 2 <sup>1, 2, 3</sup>
0006	Start on Controller SP	0023	Run Program 3 <sup>1, 2, 3</sup>
0007	Start on process variable	0024	Run Program 4 <sup>1, 2, 3</sup>
0008	End on Final Value	0025	Run Program 5 <sup>1, 2, 3</sup>
0009	End on Controller SP	0026	Run Program 6 <sup>1, 2, 3</sup>
0010	Enable x60 Mode	0027	Run Program 7 <sup>1, 2, 3</sup>
		0028	Run Program 8 <sup>1, 2, 3</sup>

1. If External Run/Hold/Abort Control is active, a negative acknowledgement (NAK) is returned.
2. If program is in Manual Hold, a negative acknowledgement (NAK) is returned.
3. If External Program Selection is active, a negative acknowledgement (NAK) is returned.

## 5.7 PROGRAMMER STATUS 1

{P} = L

This command obtains status information from the Digital Controller Programmer. The {DATA} element in the response is a five-digit decimal number which, when converted into binary form, indicates status as follows:

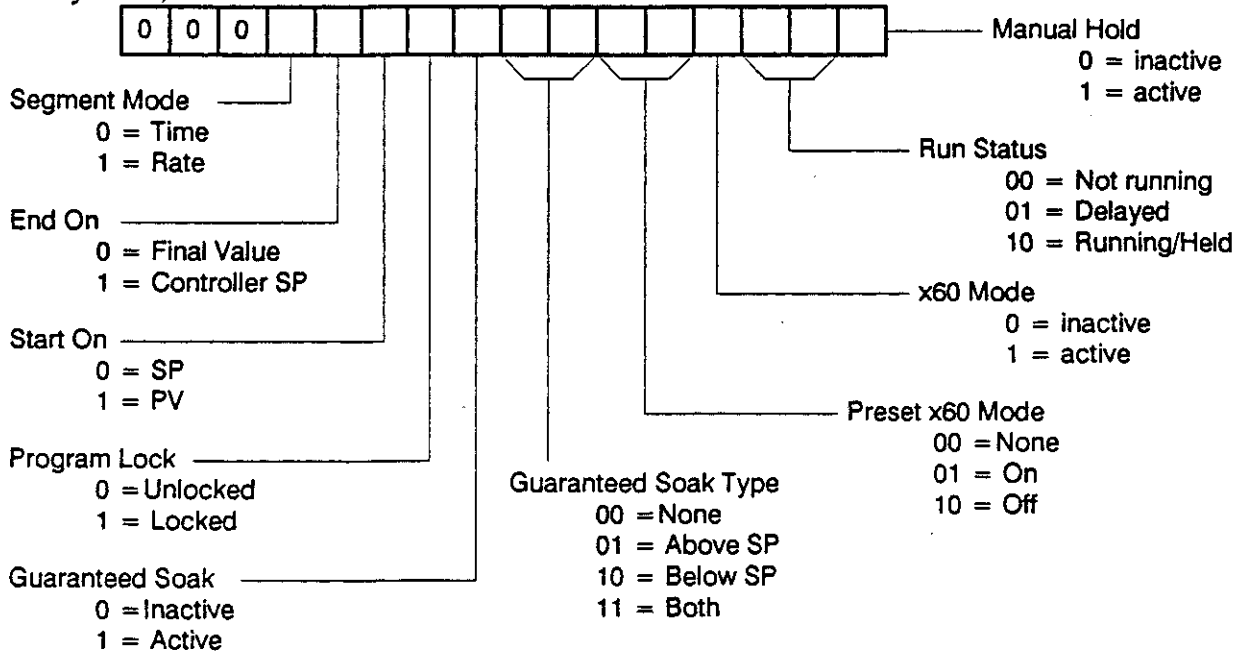

## 5.8 CURRENT SEGMENT EVENT STATUS

{P} = N

This Type 2 interrogation message returns the status of the four event outputs for the currently-executed segment (as defined by **Current Segment Number** and **Current Program Number**). The {DATA} element has six digits; the first two are 04 and each of the remaining digits (Event 1 being represented by the left-most digit etc.) may be 1 (active) or 0 (inactive).

## 5.9 POWER FAIL RECOVERY

{P} = S

This parameter defines the mode of recovery on restoration of power after a power failure. The {DATA} element decimal point position digit will be set to 0 and the remaining four digits will be set to either 0000 (Execute Cold Start -entry into Base Mode with Program Number set as when power failed and Segment Number blank) or 0001 (Execute Warm Start - program resumed from point when power failed). Any attempt to set these digits to a value outside this range will cause a negative acknowledgement (NAK) to be returned.

## 5.10 PROGRAM/SEGMENT DEFINITIONS

{P} = \

This parameter provides a single-message method of setting a given segment in a given program to a pre-defined state and of reading segment details without reference to the **Program Number** and **Segment Number** parameters. It is interrogated using a Type 5 message. The normal response to interrogation is of the form:

R{N}\14PSSFFFFFFTTTTTEA\*

where: {N} is the communications address (01 - 32 or 1 - 32)  
14 is the character count for the following data  
P is the program number  
SS is the segment number  
FFFFF is the Final Setpoint Value  
TTTTT is the Segment Time or Rate (as appropriate)  
E is a single-character hexadecimal representation of the segment's Event State.

If the Program Number or Segment Number is out of range, a negative response will be returned in the form:

R{N}\14PSSFFFFFFTTTTTEN\*

A specified segment may have details written to it by means of a Type 3/5 message sequence.

Type 3 Message: R{N}\#14PSSFFFFFFTTTTTE\*  
Reply: R{N}\14PSSFFFFFFTTTTTEI\* (positive acknowledgement)  
R{N}\14PSSFFFFFFTTTTTEN\* (negative acknowledgement)  
Type 5 Message: Raa\PSSI\*  
Reply: Raa\14PSSFFFFFFTTTTTEA\* (positive acknowledgement)  
Raa\14PSSFFFFFFTTTTTEN\* (negative acknowledgement)

### 5.11 PROGRAM SCAN TABLE

{P} = ]

This Read Only parameter may be interrogated using a Type 2 message. The normal response is of the form:

R {N} ] 25 P s s V V V V V T T T T C C C C S S S S S E E E E A \*

where: {N} is the communications address of the unit  
P is the Program Number  
ss is the Segment Number  
VVVVV is the current setpoint value  
TTTT is the Time Remaining/Hold Time (decimal position 2 assumed)  
CCCC is the number of cycles completed (0000 to 9999; if higher, will be set to <HH>, signifying "over-range"); decimal point 0 assumed  
SSSSS is the Programmer Status 1 (see Subsection 5.5.9)  
EEEE is the Event Status; each digit (Event 1 being represented by the left-most digit etc.) is 1 (active) or 0 (inactive).

## 5.12 SEGMENT MODE

{P} = \_

This parameter controls the overall programming algorithm of the instrument; Time Mode or Rate Mode. Changing this parameter will cause all other Program Definitions to be set to default values, which takes in excess of one second to complete. Software which writes to this parameter must therefore take this time into account before expecting a reply.

## 5.13 PROGRAMMER STATUS 2

{P} = ‘

This Read Only parameter applies to the Event Output and Program Control Input options. It is interrogated by a Type 2 message only and the response is in the normal five-digit {DATA} format which contains a decimal representation (decimal point position is always set to 0) of an eight-bit binary number whose bits have the following significance:

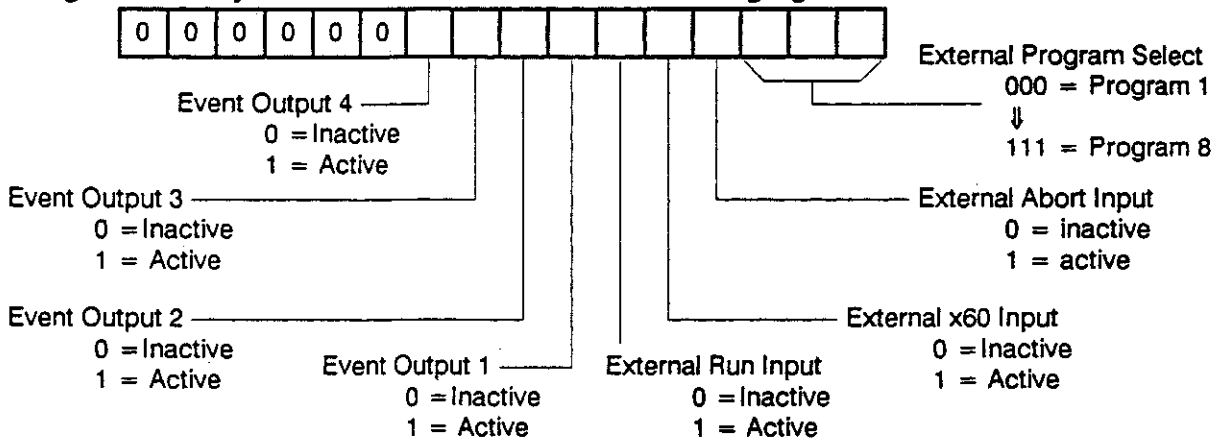

## 5.14 USER TAG NAMES

Tag names may use all alphanumeric characters, spaces and standard punctuation marks. They must consist of eight characters, with blanks being represented by space characters.

The interrogation message is the Type 2 message:

Query: R {N} U ? \*  
Reply: R {N} U 08 CCCCCCCC A \*

The tag names can be written with the usual Type 3/Type 4 message transaction:

Type 3 Message: R {N} U # 08 CCCCCCCC \*  
Reply: R {N} U 08 CCCCCCCC I \* (Positive acknowledgement)  
R {N} U 08 CCCCCCCC N \* (Negative acknowledgement)

Type 4 Message: R {N} U I \*  
Reply: R {N} U 08 CCCCCCCC A \*

## 5.15 CONTROLLER PARAMETERS (Start of Message character = L)

The controller parameters and their identifier characters are listed in Table 5-4 and their functions are listed in Table 5-5.

**Table 5-4 Controller Parameters and Identifiers**

Identifier	Parameter/Command	Comments	Type
A	Setpoint High Limit	Maximum setpoint value	Read/Write
B	Output 1 Power Limit	Safety power limit	Read/Write
C	Alarm 1 Value	Alarm 1 active at this level	Read/Write
D	Rate <sup>1</sup>	Derivative Time Constant value	Read/Write
E	Alarm 2 Value	Alarm 2 active at this level	Read/Write
F	ON/OFF Differential Value	Switching hysteresis for ON/OFF control	Read/Write
G	Scale Range Maximum	Upper limit of scaled input range	Read/Write
H	Scale Range Minimum	Lower limit of scaled input range	Read/Write
I	Reset Value <sup>1</sup> or Loop Alarm Time	Integral Time Constant value or (for ON/OFF control with Loop Alarm enabled) Loop Alarm Time value	Read/Write
J	Manual Reset	Bias Value	Read/Write
K	Overlap/Deadband Value	Portion of PB1 + PB2 over which both outputs are active	Read/Write
L	Controller Status <sup>2</sup>	Status information (see notes on this table)	Read Only
M	Process Variable Value	Universal input	Read Only
N	Output 1 Cycle Time	Used to maximise relay life	Read/Write
O	Output 2 Cycle Time	Used to maximise relay life	Read/Write
P	Proportional Band 1 Value <sup>1</sup>	Proportion of input span over which Output 1 level is proportional to the PV value	Read/Write
Q	Scale Range Decimal Point Position	Decimal point position	Read/Write
S	Setpoint Value	-	Read/Write
T	Setpoint Low Limit	Minimum value of setpoint	Read/Write
U	Proportional Band 2 Value <sup>1</sup>	Proportion of input span over which Output 2 level is proportional to the PV value	Read/Write
V	Deviation Value	PV - SP	Read Only
W	Output Power	Output power level	Read Only
Z	Setpoint Programmer Commands <sup>3</sup>	See notes on this table	Write Only
[	Recorder Output Scale Maximum	Maximum scale value for recorder output - corresponds to Input Scale Maximum	Read/Write
\	Recorder Output Scale Minimum	Minimum scale value for recorder output - corresponds to Input Scale Minimum	Read/Write
]	Scan Table	Reads main control parameters	Read Only
^	Setpoint Ramp Rate	-	Read/Write
m	Input Filter Time Constant Value	Digital filter	Read/Write
v	Process Variable Offset Value	Modified PV = Actual PV - PV Offset	Read/Write



## NOTES ON TABLE 5-4

1. These parameters cannot be modified whilst either the Pre-Tune facility or the Self-Tune facility is activated.
2. The Controller Status byte has the following format:

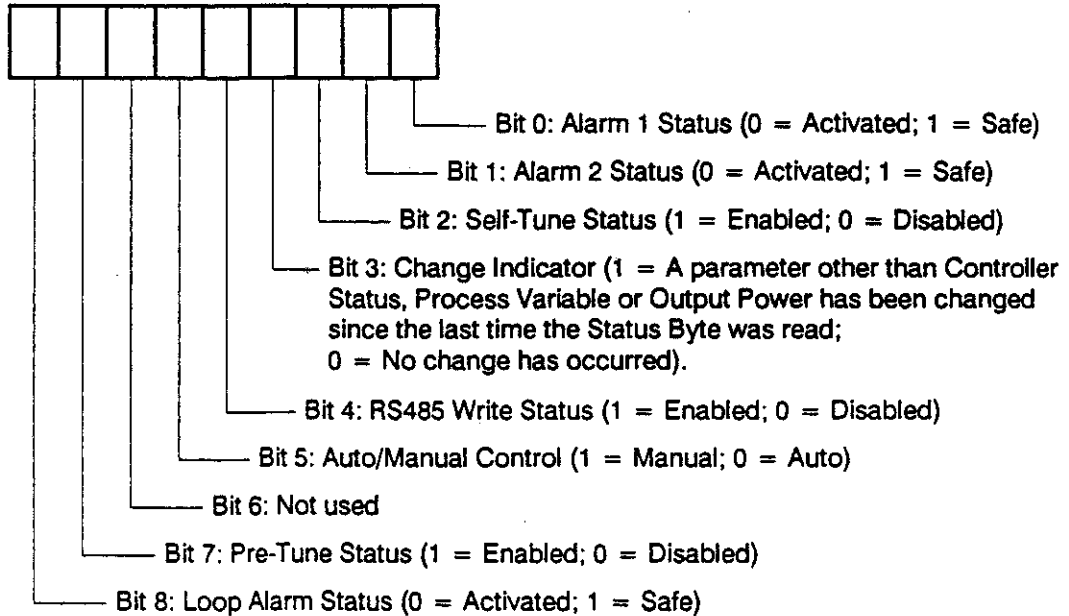

3. Only Type 3 or Type 4 messages are allowed with this parameter. In the Type 3 message, the {DATA} field must be one of eight five-digit numbers. The reply from the Digital Controller Programmer also contains the {DATA} field with the same content. When the master device issues the Type 4 message, the Digital Controller Programmer responds with the same {DATA} field content. The commands corresponding to the {DATA} field value are:

00010 = Activate Manual Control  
00020 = Activate Automatic Control  
00030 = Activate the Self-Tune facility  
00040 = De-activate the Self-Tune facility  
00050 = Request Pre-Tune (see note below)  
00060 = Abort Pre-Tune  
00130 = Activate Loop Alarm  
00140 = De-activate Loop Alarm

### NOTE

The Digital Controller Programmer will go into Pre-Tune mode only if the process variable is at least 5% of input span from the setpoint.

**Table 5-5 Controller Parameters - Functions**

Parameter	Five-digit {DATA} Element		Default Value
	Range of Adjustment	Decimal Point Position	
<b>INPUT PARAMETERS:</b>			
Process Variable (PV) <sup>2</sup>	None - Read Only Modified PV limited by Scale Range Max. and Scale Range Min.	As per input	Not applicable
Process Variable Offset <sup>3</sup>		As per input	0
Scale Range Maximum <sup>1</sup>	0 = xxxx 1 = xxx.x 2 = xx.xx 3 = x.xxx	As per input	1000
Scale Range Minimum <sup>1</sup>		As per input	0000
Scale Range		0	1
Decimal Point Position <sup>1</sup>			
Filter Time Constant	0.0 secs. to 100.0 secs:	1	2.0 secs.
<b>OUTPUT PARAMETERS:</b>			
Power Output Value <sup>4</sup>	0 to 100% for 1 output; -100% to +100% for 2 outputs.	0	-
Output 1 Power Limit <sup>8</sup>	0% to 100%	0	100%
Output 1 Cycle Time	Powers of 2 in the range 0.5secs. to 512 secs. (0.5, 1, 2, 4 etc.)	0 or 1	32 secs.
Output 2 Cycle Time	Powers of 2 in the range 0.5secs. to 512 secs. (0.5, 1, 2, 4 etc.)	0 or 1	32 secs
Recorder Output Scale Maximum Value	-1999 to 9999	As per input	Scale Range Max.
Recorder Output Scale Minimum Vale	-1999 to 9999	As per input	Scale Range Min.
<b>SETPOINT PARAMETERS:</b>			
Setpoint (SP) Value	Setpoint Low Limit to Setpoint High Limit	As per input	-
Setpoint (SP) High Limit	Current SP to Input Range Maximum	As per input	Input Range Max.
Setpoint (SP) Low Limit	Current SP to Input Range Minimum	As per input	Input Range Min.
<b>ALARM PARAMETERS:</b>			
Alarm 1 Value	Depends upon type <sup>5</sup>	As per input	As per type <sup>5</sup>
Alarm 2 Value	Depends upon type <sup>5</sup>	As per input	As per type <sup>5</sup>

Table 5-5 (Cont.) Controller Parameters - Functions

Parameter	Five-digit {DATA} Element		
	Range of Adjustment	Decimal Point Position	Default Value
<b>TUNING PARAMETERS:</b>			
Rate <sup>8</sup>	00 secs. to 99 mins. 59 secs. <sup>6</sup>	2	1min. 15 secs.
Reset <sup>8</sup>	1 sec. to 99 mins. 59 secs. <sup>6</sup>	2	5 mins. 00 secs.
Manual Reset <sup>8</sup>	0% to 100% for 1 output; -100% to +100% for 2 outputs	0 (positive) or 5 (negative)	25%
ON/OFF Differential	0.1% to 10.0% of input span	1	0.5%
Overlap/Deadband <sup>7, 8</sup>	-20% to +20% of (PB1 + PB2) Negative = Deadband Positive = Overlap	0 (positive) or 5 (negative)	0%
Proportional Band 1 (PB1)	0.0% to 999.9% of input span	1	10.0%
Proportional Band 2 (PB2) <sup>7, 8</sup>	0.0% to 999.9% of input span	1	10.0%
<b>STATUS PARAMETERS:</b>			
Controller Status (see Table 5-4)	Read Only - Not adjustable	N/A	Not applicable
Arithmetic Deviation	Read Only - Not adjustable	As per input	Not applicable
Controller Scan Tables (see Subsection 5.14)	Read Only - Not adjustable	N/A	Not applicable

**NOTES ON TABLE 5-5**

1. Applicable to DC linear inputs only.
2. If the process variable is out of range, the {DATA} byte in the reply will be <??> 0 (over-range) or <??> 5 (under-range).
3. The Process Variable Offset parameter value should be selected with care. Injudicious application of values could lead to the displayed process variable value bearing no meaningful relationship to the actual process variable value.
4. If Manual Control is not selected, this is a "Read Only" parameter (i.e. cannot be adjusted).
5. The default settings for the different alarm types are as follows:

<b>Alarm Type</b>	<b>Adjustment Range</b>	<b>Default Setting</b>
Process High Alarm:	Scale Range Min. to Scale Range Max.	Scale Range Max.
Process Low Alarm:	Scale Range Min. to Scale Range Max.	Scale Range Min.
Band Alarm:	0 to input span from setpoint	5 input units
Deviation Alarm:	± input span from setpoint	5 input units
6. {DATA} element is in the form mm.ss (mm = minutes, ss = seconds)
7. Applicable only if Output 2 is fitted.
8. Not operative if Proportional Band = 0.

## 5.16 CONTROLLER SCAN TABLE

The Controller Scan Table operation takes the form of a Type 2 interrogation command which accesses a set of information (held in the {DATA} element in the response). The response would be in the form:

L {N} ] xx aaaaa bbbbb ccccc ddddd eeeee A \*

where xx is the number of data digits in the {DATA} element to follow; this is 20 for a single-control-output instrument and 25 for a dual-control-output instrument. These digits are as described in Table 5-1 and may comprise:

aaaaa	The current setpoint value
bbbbbb	The current process variable value
ccccc	The current value of Output 1 Power (0 - 100%)
dddddd	The current value of Output 2 Power (0 - 100%), if applicable.
eeeeee	The Controller Status (see Note 2 on Table 5-4).

## 5.17 ERROR RESPONSE

The circumstances under which a message received from the master device is ignored are:

- Parity error detected
- Syntax error detected
- Timeout elapsed
- Receipt of a Type 4 message without a preceding Type 3 command message.

Negative acknowledgements will be returned if, in spite of the received message being notionally correct, the Digital Controller Programmer cannot supply the requested information or perform the requested operation. The {DATA} element of a negative acknowledgement will be indeterminate.

## 5.18 MASTER COMMUNICATIONS MODE

When the Digital Controller Programmer is set to operate as the master device over an RS485 communications link to up to 32 slave instruments (see Subsection 4.2), it uses the standard ASCII communications protocol to send the current setpoint value to each slave instrument connected and powered-up. The Digital Controller Programmer will detect all addresses which have no slave instrument and will automatically skip to the next address; the Digital Controller Programmer periodically interrogates "empty" addresses to determine whether or not they have become active. The address-to-address scan rate is five per second at 4800 Baud and ten per second at 9600 Baud.

## APPENDIX A MODEL SELECTION GUIDE

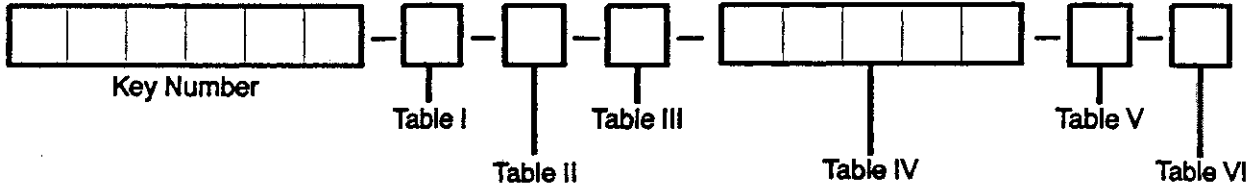

### INSTRUCTIONS

Select the desired key number. The arrow to the right marks the selections available. Make one selection from each of Tables I through VI using the column below the appropriate arrow. An asterisk denotes unrestricted availability. A letter denotes restricted availability.

Field	Meaning	Description	Selection	Availability			
				↓	↓	↓	↓
Key Number	Input Type (field-selectable)	RTD or Linear mV (factory-selected) Thermocouple (factory-selected) Linear mA (factory-selected) Linear Volt (factory-selected)	DCP101 DCP102 DCP103 DCP104	↓	↓	↓	↓
Table I	Output 1 (Control 1)	Relay	1	*	*	*	*
		SSR Driver	2	*	*	*	*
		Linear 0 - 10V (field-selectable)	3	*	*	*	*
		Linear 0 - 20mA (field-selectable)	4	*	*	*	*
		Linear 0 - 5V (field-selectable)	5	*	*	*	*
Table II	Output 2 (Control 2 or Alarm 2)	None	0	*	*	*	*
		Relay	1	*	*	*	*
		SSR Driver	2	*	*	*	*
	Output 2 (Control 2 only)	Linear 0 - 10V (field-selectable)	3	*	*	*	*
		Linear 0 - 20mA (field-selectable)	4	*	*	*	*
Linear 0 - 5V (field-selectable)		5	*	*	*	*	
Table III	Output 3 (Alarm 1 only)	None	0	*	*	*	*
		Relay	1	*	*	*	*
		SSR Driver	2	*	*	*	*
	Output 3 (Re-transmission only)	Linear 0 - 10V	3	*	*	*	*
		Linear 0 - 20mA	4	*	*	*	*
Linear 0 - 5V		5	*	*	*	*	
Table IV	Communication	No selection	0 x x x x	*	*	*	*
		RS485 ASCII Serial Communication	1 x x x x	*	*	*	*
	Power Supply	Power supply 90 - 264 V ac	x 1 x x x	*	*	*	*
		Power supply 24 - 48V ac/dc	x 2 x x x	*	*	*	*
	Digital Outputs	No selection	x x 0 x x	*	*	*	*
		Event Outputs	x x 1 x x	*	*	*	*
	Digital Inputs	No selection	x x x 0 x	*	*	*	*
Remote Program Control Inputs		x x x 1 x	*	*	*	*	
Real Time Clock	No selection	x x x x 0	*	*	*	*	
	Real Time Clock	x x x x 1	*	*	*	*	
Table V	Language Selection	English Operator & Installation Manuals	0	*	*	*	*
		French Operator & Installation Manuals	1	*	*	*	*
		German Operator & Installation Manuals	2	*	*	*	*

Field	Meaning	Description	Selection	Availability			
Table VI		None	0	*	*	*	*
		Special instrument requirement	S	*	*	*	*

Additional Literature	Description	Ref.	Availability			
Operator's Manual	English	EN11-6174	*	*	*	*
	French	FR11-6174	*	*	*	*
	German	GE11-6174	*	*	*	*
Installation Manual	English	EN11-6173	*	*	*	*
	French	FR11-6173	*	*	*	*
	German	GE11-6173	*	*	*	*

Upgrade Kits	Ref.	Availability			
Relay Output PWA	46189010-501	*	*	*	*
SSR Output PWA	46189011-501	*	*	*	*
Linear Output PWA	46189012-501	*	*	*	*
ASCII Comms. PWA	46189013-501	*	*	*	*
DCP 100 Program Editor & Configurator Software	46189404-501	*	*	*	*

## INPUT TYPE

Code	Description
1	RTD or DC (mV)
2	Thermocouple
3	DC (mA)
4	DC (V)

The input ranges available (selectable on the front panel) are:

### For Thermocouple Inputs:

Type	Input Range	Displayed Code	Type	Input Range	Displayed Code
R	0 - 1650°C	1127	K	-200 - 760°C	1719
R	32 - 3002°F	1128	K	-328 - 1399°F	1720
S	0 - 1649°C	1227	K	-200 - 1373°C	1723
S	32 - 3000°F	1228	K	-328 - 2503°F	1724
J	0.0 - 205.4°C	1415	L	0.0 - 205.7°C	1815
J	32.0 - 401.7°F	1416	L	32.0 - 402.2°F	1816
J	0 - 450°C	1417	L	0 - 450°C	1817
J	32 - 842°F	1418	L	32 - 841°F	1818
J	0 - 761°C *	1419	L	0 - 762°C	1819
J	32 - 1401°F	1420	L	32 - 1403°F	1820
T	-200 - 262°C	1525	B	211 - 3315°F	1934
T	-328 - 503°F	1526	B	100 - 1824°C	1938
T	0.0 - 260.6°C	1541	N	0 - 1399°C	5371
T	32.0 - 501.0°F	1542	N	32 - 2550°F	5324

\* Default state

**For RTD Inputs:**

Input Range	Displayed Code	Input Range	Displayed Code
0 - 800°C *	7220	0.0 - 100.9°C	2295
32 - 1471°F	7221	32.0 - 213.6°F	2296
32 - 571°F	2229	-200 - 206°C	2297
-100.9 - 100.0°C	2230	-328 - 402°F	2298
-149.7 - 211.9°F	2231	-100.9 - 537.3°C	7222
0 - 300°C	2251	-149.7 - 999.1°F	7223

\* Default state

**For DC Inputs:**

Input Range	Displayed Code	Input Range	Displayed Code
0 - 20mA	3413	0 - 5V	4445
4 - 20mA *	3414	1 - 5V	4434
0 - 50mV	4443	0 - 10V *	4446
10 - 50mV	4499	2 - 10V	4450

\* Default state

**OUTPUT 1 TYPE**

Code	Description
1	Relay (Control Output 1)
2	DC/SSR (Control Output 1)
3	DC 0 - 10V (Control Output 1)
4	DC 0 - 20mA (Control Output 1)
5	DC 0 - 5V (Control Output 1)
7	DC 4 - 20mA (Control Output 1)

Default = Control Output 1, type as per Output 1 code (Direct-acting).

**OUTPUT 2 TYPE**

Code	Description
0	Not fitted
1	Relay (Control Output 2/Alarm 2 output)
2	DC/SSR Control Output 2/Alarm 2 output)
3	DC 0 - 10V (Control Output 2 only)
4	DC 0 - 20mA (Control Output 2 only)
5	DC 0 - 5V (Control Output 2 only)
7	DC 4 - 20mA (Control Output 2 only)

Default = Alarm 2 Output, Process Low Direct-Acting

Default = Control Output 2, type as Output 2 code)

### OUTPUT 3 TYPE

Code	Description	
0	Not fitted	
1	Relay (Alarm 1 output only)	} Default = Alarm 1 Output, Process High Direct-acting
2	DC/SSR (Alarm 1 output only)	
3	DC 0 - 10V (Recorder Output only)	} Default = Recorder Output (PV)
4	DC 0 - 20mA (Recorder Output only)	
5	DC 0 - 5V (Recorder Output only)	
7	DC 4 - 20mA (Recorder Output only)	

### OPTIONS

Code	Description
1 x x x x	RS485 Communications
x 2 x x x	24V (nominal) AC/DC Line Supply
x x 1 x x	Event Outputs (4 relays)
x x x 1 x	Remote Program Control Inputs (6 dry contacts)
x x x x 1	Real Time Clock



## APPENDIX B PRODUCT SPECIFICATION

### UNIVERSAL INPUT

#### General

Maximum per Unit:	One
Input Sample Rate:	Four samples/second
Digital Input Filter:	Time constant selectable from front panel - 0.0 (i.e. OFF), 0.5 to 100.0 seconds in 0.5-second increments.
Input Resolution:	14 bits approximately; always four times better than display resolution.
Input Impedance:	Greater than 100M $\Omega$ resistive (except for DC mA and V inputs).
Isolation:	Universal input isolated from all outputs except SSR at 240V AC.
Process Variable Offset:	Adjustable $\pm$ input span.

#### Thermocouple

Ranges selectable from front panel:

Type	Input Range	Type	Input Range	Type	Input Range
R	0 - 1650 $^{\circ}$ C	T	-200 - 262 $^{\circ}$ C	L	0.0 - 205.7 $^{\circ}$ C
R	32 - 3002 $^{\circ}$ F	T	-328 - 503 $^{\circ}$ F	L	32.0 - 402.2 $^{\circ}$ F
S	0 - 1649 $^{\circ}$ C	T	0.0 - 260.6 $^{\circ}$ C	L	0 - 450 $^{\circ}$ C
S	32 - 3000 $^{\circ}$ F	T	32.0 - 501.0 $^{\circ}$ F	L	32 - 841 $^{\circ}$ F
J	0.0 - 205.4 $^{\circ}$ C	K	-200 - 760 $^{\circ}$ C	L	0 - 762 $^{\circ}$ C
J	32.0 - 401.7 $^{\circ}$ F	K	-328 - 1399 $^{\circ}$ F	L	32 - 1403 $^{\circ}$ F
J	0 - 450 $^{\circ}$ C	K	-200 - 1373 $^{\circ}$ C	B	211 - 3315 $^{\circ}$ F
J	32 - 842 $^{\circ}$ F	K	-328 - 2503 $^{\circ}$ F	B	100 - 1824 $^{\circ}$ C
J	0 - 761 $^{\circ}$ C *			N	0 - 1399 $^{\circ}$ C
J	32 - 1401 $^{\circ}$ F			N	32 - 2550 $^{\circ}$ F

\* Default setting

Calibration:	Complies with BS4937, NBS125 and IEC584.
Sensor Break Protection:	Break detected within two seconds. Control outputs set to OFF (0% power); Alarms operate as if the process variable has gone over-range.

## Resistance Temperature Detector (RTD) and DC mV

Ranges selectable from front panel:

0 - 800°C *	32.0 - 213.6°F	
32 - 1471°F	-200 - 206°C	
32 - 571°F	-328 - 402°F	
-100.9 - 100.0°C	-100.9 - 537.3°C	
-149.7 - 211.9°F	-149.7 - 999.1°F	
0 - 300°C	0 - 50mV	
0.0 - 100.9°C	10 - 50mV	* Default setting

Type and Connection:	Three-wire Pt100
Calibration:	Complies with BS1904 and DIN43760.
Lead Compensation:	Automatic scheme.
RTD Sensor Current:	150 $\mu$ A (approximately)
Sensor Break Protection:	Break detected within two seconds. Control outputs set to OFF (0% power); Alarms operate as if the process variable has gone under-range.

## DC Linear

Ranges Selectable from Front Panel:

0 - 20mA	1 - 5V
4 - 20mA	0 - 10V
0 - 5V	2 - 10V

Scale Range Maximum:	-1999 to 9999. Decimal point as required.
Scale Range Minimum:	-1999 to 9999. Decimal point as for Scale Range Maximum.
Minimum Span:	1 display LSD.
Sensor Break Protection:	Applicable to 4 - 20mA, 1 - 5V and 2 - 10V ranges only. Break detected within two seconds. Control outputs set to OFF (0% power); Alarms operate as if the process variable has gone under-range.

## OUTPUT 1

### General

Types Available:	Relay (as standard), SSR and DC as options.
------------------	---

### Relay

Contact Type:	Single pole double throw (SPDT).
---------------	----------------------------------

Rating: 2A resistive at 120/240V AC.  
Lifetime: > 500,000 operations at rated voltage/current.  
Isolation: Inherent.

#### **SSR Drive/TTL**

Drive Capability: SSR > 4.3V DC into 250 $\Omega$  minimum.  
Isolation: Not isolated from input or other SSR outputs.

#### **DC**

Resolution: Eight bits in 250mS (10 bits in 1 second typical, > 10 bits in > 1 second typical).  
Update Rate: Every control algorithm execution.  
Ranges: 0 - 20mA, 4 - 20mA, 0 - 10V, 0 - 5V  
Load Impedance: 0 - 20mA: 500 $\Omega$  maximum  
4 - 20mA: 500 $\Omega$  maximum  
0 - 10V: 500 $\Omega$  minimum  
0 - 5V: 500 $\Omega$  minimum  
Isolation: Isolated from all other inputs and outputs.  
Range Selection Method: Link jumper or DIP switch and front panel code.

#### **OUTPUT 2**

##### **General**

Types Available: Relay, SSR and DC.

##### **Relay**

Contact Type: Single pole double throw (SPDT).  
Rating: 2A resistive at 120/240V AC.  
Lifetime: > 500,000 operations at rated voltage/current.  
Isolation: Inherent.

#### **SSR Drive/TTL**

Drive Capability: SSR > 4.3V DC into 250 $\Omega$  minimum.  
Isolation: Not isolated from input or other SSR outputs.

#### **DC**

Resolution: Eight bits in 250mS (10 bits in 1 second typical, > 10 bits in > 1 second typical).  
Update Rate: Every control algorithm execution.

Ranges:	0 - 20mA, 4 - 20mA, 0 - 10V, 0 - 5V
Load Impedance:	0 - 20mA: 500Ω maximum 4 - 20mA: 500Ω maximum 0 - 10V: 500Ω minimum 0 - 5V: 500Ω minimum
Isolation:	Isolated from all other inputs and outputs.
Range Selection Method:	Link jumper or DIP switch and front panel code.

### OUTPUT 3

#### General

Types Available:	Relay, DC linear (Recorder Output only)
------------------	---

#### Relay

Contact Type:	Single pole double throw (SPDT).
Rating:	2A resistive at 120/240V AC.
Lifetime:	> 500,000 operations at rated voltage/current.
Isolation:	Inherent.

#### SSR Drive/TTL

Drive Capability:	SSR > 4.3V DC into 250Ω minimum.
Isolation:	Not isolated from input or other SSR outputs.

#### DC

Resolution:	Eight bits in 250mS (10 bits in 1 second typical, > 10 bits in > 1 second typical).
Update Rate:	Every control algorithm execution.
Ranges:	0 - 20mA, 4 - 20mA, 0 - 10V, 0 - 5V
Load Impedance:	0 - 20mA: 500Ω maximum 4 - 20mA: 500Ω maximum 0 - 10V: 500Ω minimum 0 - 5V: 500Ω minimum
Isolation:	Isolated from all other inputs and outputs.
Range Selection Method:	Link jumper or DIP.

### LOOP CONTROL

Automatic Tuning Types:	Pre-Tune and Self-Tune.
Proportional Bands:	0 (OFF), 0.5% - 999.9% of input span at 0.1% increments.

Reset (Integral Time Constant):	1s - 99min 59s and OFF
Rate (Derivative Time Constant):	0 (OFF) - 99 min 59 s.
Manual Reset (Bias):	Added each control algorithm execution. Adjustable in the range 0 - 100% of output power (single output) or -100% to +100% of output power (dual output).
Deadband/Overlap:	-20% to +20% of Proportional Band 1 + Proportional Band 2.
ON/OFF Differential:	0.1% to 10.0% of input span.
Auto/Manual Control:	User-selectable with "bumpless" transfer into and out of Manual Control.
Cycle Times:	Selectable from 0.5secs to 512 secs in binary steps.
Setpoint Range:	Limited by Setpoint Maximum and Setpoint Minimum.
Setpoint Maximum:	Limited by Setpoint and Range Maximum.
Setpoint Minimum:	Limited by Range Minimum and Setpoint.
Setpoint Ramp:	Ramp rate selectable 1 - 9999 LSDs per hour and infinite. Number displayed is decimal-point-aligned with selected range.

#### **ALARM CONTROL**

Maximum Number of Alarms:	Two "soft" alarms plus Loop Alarm
Max. No. of Outputs Available:	Up to two outputs can be utilised for alarm purposes.
Combinatorial Alarms:	Logical OR or AND of alarms to an individual hardware output is available.

#### **PROGRAM FACILITIES**

Programs (profiles):	Eight, each with free-form segments
Length of Program:	Adjustable in the range 1 to 16 segments; programs cascable - maximum length 121 segments
Segment Types:	Ramp, Soak, Join, Repeat or End
Program Cycling:	Range 1 to 9999, infinite
Delayed Start:	May be set in the range 0 to 99:59 (hours:minutes). One setting applies to all programs

Control:	Run, Hold, Abort, x60 (local or remote) Select Program (local or remote) Jump to next segment.
Start From:	Either current process variable value or controller setpoint value
End On:	Final Value or controller setpoint
Guaranteed Soak:	Off, below setpoint only, above setpoint only or above and below setpoint. On ramps only, on soaks only or on both ramps and soaks. Guaranteed Soak band may be set from 0 to input span.
Timebase:	Either hours:minutes or minutes:seconds (x60); x60 pre-programmable or may be set during Program Run.
Segment Time:	May be set in the range 0 to 99:59 (hours:minutes or minutes:seconds)
Ramp Rate:	0 to 9999 least significant digits per hour or minute

#### **END OF PROGRAM OUTPUT**

Type:	Relay
Contact Type:	Single pole, double throw (SPDT Form C)
Rating:	5A resistive @ 120/240V AC
Lifetime:	> 100,000 operations @ rated voltage/current
Isolation:	Inherent

#### **EVENT OUTPUTS - OPTION**

Type:	Relay (4)
Contact Type:	Single pole, single throw; normally open.
Rating:	5A resistive @ 120/240V AC
Lifetime:	> 100,000 operations @ rated voltage/current
Isolation:	Inherent
Programmability:	Each event is programmable to either OFF or ON for each segment.

#### **DIGITAL (REMOTE PROGRAM CONTROL) INPUTS - OPTION**

Type:	Voltage-free contact and TTL-compatible
-------	---

Number available:	Six: (a) Run/Hold, x60, Abort (b) Three (binary-coded) Program Select
Active State:	Max. Contact Resistance (Closed) = 50 $\Omega$ Max. Voltage (TTL) for "0" = 0.8V Min. Voltage for "0" = -0.6V
Non-Active State:	Min. Contact Resistance (Open) = 5,000 $\Omega$ Min. Voltage (TTL) for "1" = 2.0V Max. Voltage for "1" = 24.0V
Max. Input Delay (OFF - ON):	0.25 seconds
Min. Input Delay (ON - OFF):	0.25 seconds

### RS485 SERIAL COMMUNICATIONS (OPTION)

**System:** Multi-drop, half duplex. May operate in Slave Mode (slave address 1 - 32) or Master Mode (transmitting current setpoint value to up to 32 controllers). Transmitting device drives lines to appropriate levels; the outputs on each non-transmitting device are set to a high impedance in order that other devices may transmit.

**NOTE:** All instruments having an RS485 serial communications facility conform to the following standard:

1. Each transmitter must release the transmission lines within 6ms of the last character in a message; delays due to buffers such as those in UARTs within the master device must be taken into account.
2. A transmitter must not start transmission until 6ms has elapsed since reception of the last character of a message.

To avoid line contention problems, ensure that all devices connected to the communications port on a instrument follow the same standard.

<b>Data Format:</b>	Even parity, seven data bits and one stop bit.
<b>Baud Rate:</b>	Selectable: 1200, 2400, 4800 (default) or 9600 Baud.

### PERFORMANCE

#### Reference Conditions

Generally as BS5558.

Ambient Temperature:	20°C $\pm$ 2°C
Relative Humidity:	60 - 70%
Supply Voltage:	90 - 264V AC 50Hz $\pm$ 1%
Source Resistance:	< 10 $\Omega$ for thermocouple input

Lead Resistance: < 0.1 $\Omega$ /lead balanced (Pt100)

### Performance Under Reference Conditions

Common Mode Rejection: > 120dB at 50/60Hz giving negligible effect at up to 264V 50/60Hz.

Series Mode Rejection: > 500% of span (at 50/60Hz) causes negligible effect.

### DC Linear Inputs

Measurement Accuracy:  $\pm 0.25\%$  of span  $\pm 1$ LSD.

### Thermocouple Inputs

Measurement Accuracy:  $\pm 0.25\%$  of span  $\pm 1$ LSD. NOTE: Reduced performance with Type "B" Thermocouple between 100 - 600 $^{\circ}$ C (212 - 1112 $^{\circ}$ F).

Linearisation Accuracy: Better than  $\pm 0.2^{\circ}$ C any point, any 0.1 $^{\circ}$ C range ( $\pm 0.05^{\circ}$ C typical). Better than  $\pm 0.5^{\circ}$ C any point, any 1 $^{\circ}$ C range.

Cold Junction Compensation: Better than  $\pm 0.7^{\circ}$ C.

### RTD Inputs

Measurement Accuracy:  $\pm 0.25\%$  of span  $\pm 1$ LSD

Linearisation Accuracy: Better than  $\pm 0.2^{\circ}$ C any point, any 0.1 $^{\circ}$ C range ( $\pm 0.05^{\circ}$ C typical). Better than  $\pm 0.5^{\circ}$ C any point, any 1 $^{\circ}$ C range.

### DC Outputs - Accuracy

Output 1:  $\pm 0.5\%$  (mA @ 250 $\Omega$ , V @ 2k $\Omega$ ); 2% underdrive (4 - 20mA) and overdrive applies.

Output 2:  $\pm 0.5\%$  (mA @ 250 $\Omega$ , V @ 2k $\Omega$ ); 2% underdrive (4 - 20mA) and overdrive applies.

Output 3 (Recorder Output):  $\pm 0.25\%$  (mA @ 250 $\Omega$ , V @ 2k $\Omega$ ); Degrades linearly to  $\pm 0.5\%$  for increasing burden (to specification limits).

### Operating Conditions

Ambient Temperature (Operating): 0 $^{\circ}$ C to 55 $^{\circ}$ C

Ambient Temperature (Storage): -20 $^{\circ}$ C to 80 $^{\circ}$ C

Relative Humidity: 20% - 95% non-condensing



Supply Voltage:	90 - 264V AC 50/60Hz (standard) 20 - 50V AC 50/60Hz or 22 - 65V DC (option)
Source Resistance:	1000 $\Omega$ maximum (thermocouple)
Lead Resistance:	50 $\Omega$ per lead maximum balanced (Pt100)

#### Performance Under Operating Conditions

Temperature Stability:	0.01% of span/ $^{\circ}$ C change in ambient temp.
Cold Junction Compensation (thermocouple only):	Better than $\pm 1^{\circ}$ C.
Supply Voltage Influence:	Negligible.
Relative Humidity Influence:	Negligible
Sensor Resistance Influence:	Thermocouple 100 $\Omega$ : < 0.1% of span error Thermocouple 1000 $\Omega$ : < 0.5% of span error RTD Pt100 50 $\Omega$ /lead: < 0.5% of span error
Radiated RF Field Influence:	Degradation of Output 1 accuracy to 3% at spot frequencies in the range 80 - 350MHz at field strength of 10V/m.

#### ENVIRONMENTAL

Operating Conditions:	See <b>PERFORMANCE</b> .
EMI Susceptibility:	Designed to meet EN50082-1:1992 and EN50082-2:1995.
EMI Emissions:	Designed to meet EN50081-1:1992 and EN50081-2:1994.
Safety Considerations:	Designed to comply with EN 61010-1:1993.
Supply Voltage:	90 - 264V AC 50/60Hz (standard) 20 - 50V AC 50/60Hz or 22 - 65V DC (option)
Power Consumption:	4 watts approximately.
Front Panel Sealing:	To IP65.

#### PHYSICAL

Dimensions:	Depth - 100mm approximately Front Panel: Width - 96mm, Height - 96mm (1/4-DIN)
Mounting:	Plug-in with panel mounting fixing strap. Panel cut-out 92mm x 92mm.
Terminals:	Screw type (combination head).
Weight:	0.21kg maximum

## Alphabetic Index

<b>I</b>			
24V AC/DC Supply			
Connections	2-5		
Voltage range	2-5		
<b>A</b>			
Alarm 1 Type parameter	4-4		
Alarm 2 Type parameter	4-4		
Alarm Inhibit Facility			
Description of	4-6		
Alarm Inhibit parameter	4-4		
<b>B</b>			
Baud Rate parameter	4-6		
<b>C</b>			
CJC Enable/Disable parameter	4-6		
Communications Address parameter	4-6		
Communications Message Format	5-1		
Control Action parameter	4-4		
Controller Dimensions	B-9		
<b>D</b>			
Digital Input Option			
Setting up	4-3		
Digital Input Option PCB			
Installation/removal	3-4		
<b>E</b>			
End of Message Character	5-2		
Event Output Option			
Setting up	4-3		
Event Output Option PCB			
Installation/removal	3-5		
<b>F</b>			
Front Panel			
Dimensions	2-1		
Projection from mounting panel	2-2		
Fuse Rating			
24V AC/DC supply	2-5		
Mains (line) supply	2-5		
<b>H</b>			
Hardware Definition Codes	4-1		
<b>I</b>			
Input Type Selection	3-6		
<b>L</b>			
Line (Mains) Supply			
Connections	2-5		
Power consumption	2-5		
Voltage range	2-5		
Lock Code parameter	4-6		
<b>M</b>			
Main Dimensions	2-2		
Mains (Line) Supply			
Connections	2-5		
Power consumption	2-5		
Voltage range	2-5		
Master Communications Mode			
Selection of	4-3		
Message Types	5-1		
<b>O</b>			
Output 1 Type Selection	3-7		
Output 2 Option PCB			
Removal/replacement	3-3		
Output 2 Type Selection	3-8		
Output 2 Usage parameter	4-5		
Output 3 Option PCB			
Removal/replacement	3-3		
Output 3 Type Selection	3-8		
Output 3 Usage parameter	4-5		
Output Relay Contact Rating			
End of Program and Event outputs	2-7		
Outputs 1, 2 and 3	2-7		
<b>P</b>			
Panel-Mounting			
Cut-out dimensions			
(multiple installation)	2-1		
Cut-out dimensions			
(single installation)	2-1		
Maximum panel thickness	2-1		
Setpoint Programmer dimensions	2-1		
Panel-Mounting Procedure	2-2		
Primary Input Range parameter	4-4		
<b>R</b>			
RS485 Serial Communications Option PCB			
Removal/replacement	3-3		

## S

Scan Table (Controller) Command	5-15
Scan Table (Program) Command	5-9
Segment Mode parameter	4-5
Sensor Break	
Effect on outputs (DC linear inputs)	B-2
Effect on outputs (RTD inputs)	B-2
Effect on outputs (thermocouple inputs)	B-1
Slave Communications Mode	
Selection of	4-3
Start of Message Character	5-2

### TECHNICAL ASSISTANCE

*If you encounter a problem with your unit, please review all the configuration data to verify that your selections are consistent with your application; (i.e. Inputs, Outputs, Alarms, Limits, etc.). If the problem persists after checking the above parameters, you can get technical assistance by calling the following:*

*In the U.S.A.:           1-800-423-9883*

*In other countries:   See following Honeywell  
                          Service Center addresses*