

RM7890D; RM7895E,F 7800 SERIES Relay Modules

PRODUCT DATA



APPLICATION

The Honeywell RM7890D; RM7895E,F Relay Modules are microprocessor based integrated burner controls for automatically fired gas single burner infrared heater applications. The RM7890D; RM7895E,F System consists of the relay module, wiring subbase, amplifier and, for the RM7895E,F, the purge timer. Options include Keyboard Display Module (KDM), personal computer interface, Data ControlBus™ Module, remote display mounting, first-out expanded annunciator and Combustion System Manager™ Software.

The RM7890D; RM7895E,F is programmed to provide a level of safety, functional capability and features beyond the capacity of conventional controls.

Higher impressed flame rod voltage makes the RM7890D, RM7895E,F suitable for infrared heaters and some unstable/hard to sense flame rod applications.

NOTE: Be sure to check local codes for acceptance of the longer pilot flame establishing times.

The RM7890D; RM7895E,F provides automatic burner sequencing, flame supervision, system status indication, system or self-diagnostics and troubleshooting.

This document provides installation and static checkout instructions. Other applicable publications are:

Form Number	Description
63-2278	Q7700A Network Interface Unit Product Data
65-0084	Q7800A,B 22-Terminal Wiring Subbase Product Data
65-0090	S7800A Keyboard Display Module Product Data.
65-0091	S7810A Data ControlBus Module™ Product Data
65-0095	S7820 Remote Reset Module Product Data
65-0097	221729C Dust Cover Packing Sheet
65-0101	S7830 Expanded Annunciator Product Data
65-0109	R7824, R7847, R7848, R7849, R7851, R7861, R7886 Flame Amplifiers for the 7800 SERIES Product Data
65-0131	221818A Extension Cable Assembly Product Data
65-0229	7800 SERIES Relay Modules Checkout and Troubleshooting

FEATURES

- **Safety features:**
 - **Closed loop logic test.**
 - **Dynamic AMPLI-CHECK™ circuitry.**
 - **Dynamic input check.**
 - **Dynamic safety relay test.**
 - **Dynamic self-check logic.**

Contents

Application	1
Features	1
Specifications	2
Ordering Information	2
Principal Technical Features	6
Installation	7
Wiring	10
Assembly	13
Troubleshooting	24



- Expanded safe-start check.
- Internal hardware status monitoring.
- Tamper resistant timing and logic.
- Access for external electrical voltage checks.
- Dynamic airflow switch check feature (RM7895F).
- Application flexibility.
- Dependable, long-term operation provided by microcomputer technology.
- Five light emitting diodes (LEDs) for sequence information.
- Interchangeable rectification type plug-in flame amplifiers.
- Nonvolatile memory of RM7890D; RM7895E,F retains history files and sequencing status after loss of power.
- Selectable relight or lockout on loss of flame.
- Sequence status.
- Sequence time.
- Total cycles of operation.
- Total hours of operation.
- Fault history providing the six most recent faults:
 - Cycles of operation at the time of the fault.
 - Expanded annunciator data at the time of the fault.
 - Fault message and code.
 - Hours of operation at the time of the fault.
 - Sequence status at the time of the fault.
 - Sequence time at the time of the fault.
- Diagnostic information:
 - Device type.
 - Flame amplifier type.
 - Flame failure response time.
 - Manufacturing code.
 - On/Off status of all digital inputs and outputs.
 - Software revision and version of RM7890/ RM7895 and optional Keyboard Display Module.
 - Status of configuration jumpers.

OPTIONAL FEATURES

- Communication interface capability.
- First-out annunciation and system diagnosis are provided by a two-row by 20-column display located on the optional keyboard display module (KDM).
- First-out expanded annunciation with 26 LEDs for limits and interlocks.
- Local or remote annunciation of RM7890D; RM7895E,F operation and fault information.
- Report generation.
- Remote reset.
- Burner controller data using S7800 Keyboard Display:
 - Expanded annunciator status.
 - Flame signal strength.
 - Hold status.
 - Lockout/alarm status.

SPECIFICATIONS

Electrical Ratings:

See Table 1.

Voltage and Frequency:

120 Vac (+10/-15%), 50/60 Hz ($\pm 10\%$).

Power Dissipation: 10W maximum.

Maximum Total Connected Load: 2000 VA.

Fusing Total Connected Load: 15A maximum, type SC or equivalent.

ORDERING INFORMATION

When purchasing replacement and modernization products from your TRADELINE® wholesaler or distributor, refer to the TRADELINE® Catalog or price sheets for complete ordering number.

If you have additional questions, need further information, or would like to comment on our products or services, please write or phone:

1. Your local Honeywell Automation and Control Products Sales Office (check white pages of your phone directory).
2. Honeywell Customer Care
1885 Douglas Drive North
Minneapolis, Minnesota 55422-4386

In Canada—Honeywell Limited/Honeywell Limitée, 35 Dynamic Drive, Toronto, Ontario M1V 4Z9.

International Sales and Service Offices in all principal cities of the world. Manufacturing in Australia, Canada, Finland, France, Germany, Japan, Mexico, Netherlands, Spain, Taiwan, United Kingdom, U.S.A.

Table 1. RM7890D, RM7895E,F Terminal Ratings.

Terminal No.	Description	Ratings
G	Flame Sensor Ground ^a	—
Earth G	Earth Ground ^a	—
L2(N)	Line Voltage Common	—
3 (RM7890D)	Line Voltage Supply (L1)	120 Vac (+10%/-15%), 50/60 Hz (±10%). ^b
3 (RM7895E,F)	Alarm	120 Vac, 1A pilot duty.
4 (RM7890D)	Alarm	120 Vac, 1A pilot duty.
4 (RM7895E,F)	Burner Motor	120 Vac, 9.8AFL, 58.8ALR (inrush).
5 (RM7890D)	Unused	—
5 (RM7895E,F)	Line Voltage Supply (L1)	120 Vac (+10%/-15%), 50/60 Hz (±10%). ^b
6 (RM7890D)	Burner Controller and Limits	120 Vac 8A Run, 43A inrush. ^b
6 (RM7895E,F)	Burner Controller and Limits	120 Vac, 1 mA.
7 (RM7890D)	Unused	—
7 (RM7895E,F)	Airflow Interlock	120 Vac, 8A run, 43A inrush.
8	Pilot Valve/Ignition	120 Vac. ^c
9	Main Fuel Valve	
10	Ignition	
F(11)	Flame Sensor	60–345 Vac, current limited.
12 to 22	Unused	—

^a The RM7890D and RM7895 must have an earth ground providing a connection between the wiring subbase and the control panel or equipment. The earth ground wire must be capable of conducting the current to blow a 15A Fast Blow, Type SC, fuse (or equivalent) in the event of an internal short circuit. The RM7890D and RM7895 need a low impedance ground connection to the equipment frame, which, in turn, needs a low impedance connection to earth ground.

^b 2000 VA maximum connected load to the Relay Module.

^c See Table 2 and 3.

Table 2. Combinations for terminals 8, 9 and 10.

Combination No.	Pilot Valve (Terminal 8)	Main Fuel Valve (Terminal 9)	Ignition (Terminal 10)
1	C	F	A
2	B	F	No Load
4	F	F	A
5	F	No Load	A
6	D	F	A
8	D	D	A
9	D	No Load	A

Table 3. Composition of Each Combination.

A	B	C	D	F
4.5A ignition	50 VA Pilot Duty plus 4.5A ignition.	180 VA ignition plus motor valves with: 660 VA inrush 360 VA open 250 VA hold.	2A Pilot Duty	65 VA Pilot Duty plus Motor valves with: 3850 VA inrush 700 VA open 250 VA hold.

Environmental Ratings:

Ambient Temperature:

Operating: -40°F to 140°F (-40°C to 60°C).

Storage: -60°F to 150°F (-51°C to 66°C).

Humidity: 85% relative humidity continuous, noncondensing.

Vibration: 0.5G environment.

Dimensions:

See Fig. 1 and 2.

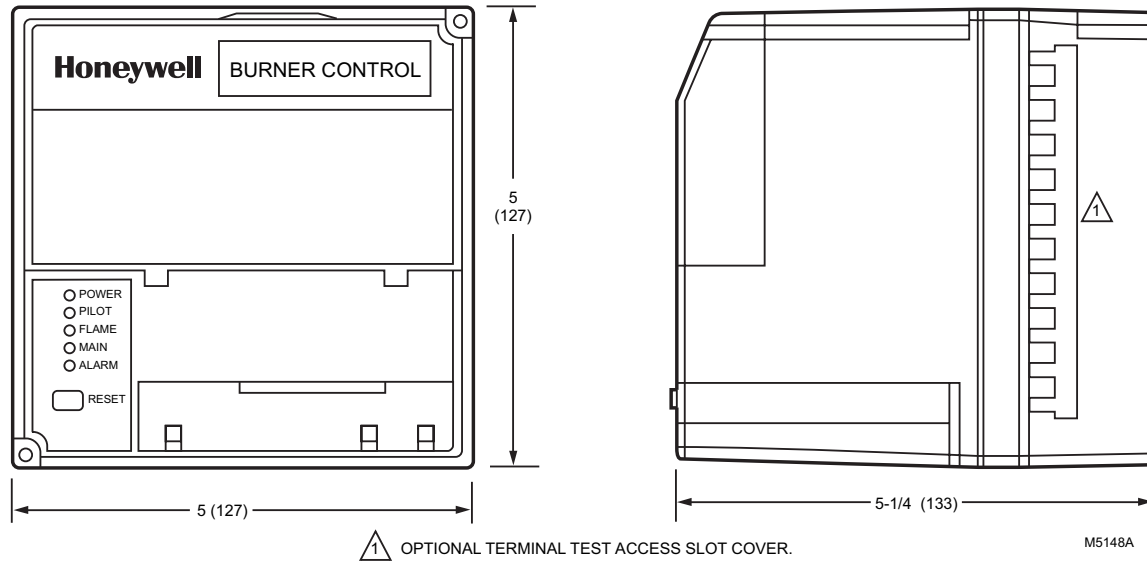

Fig. 1. Mounting dimensions of RM7890, RM7895 Relay Module and Q7800A Subbase in in. (mm).

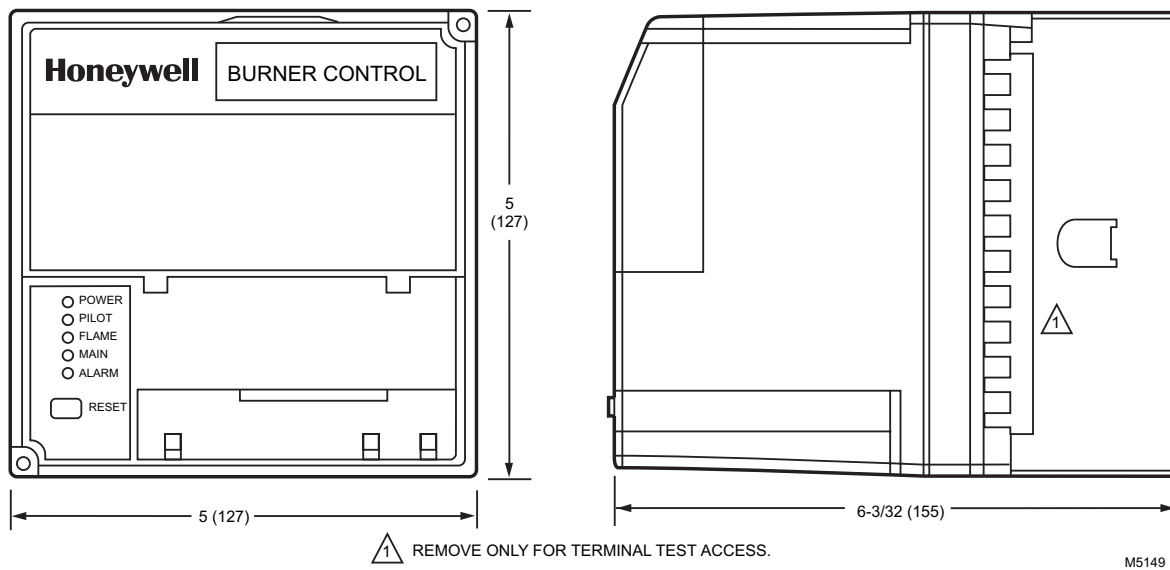

Fig. 2. Mounting dimensions of RM7890, RM7895 Relay Module and Q7800B Subbase in in. (mm).

Weight:
RM7890, RM7895 with Dust Cover: 1 lb, 13 oz (829 grams) unpacked.

Approvals:
Underwriters Laboratories Inc. Listed: File No. MP268, Guide no. MCCZ.
Canadian Standards Association Certified: LR9S329-3.
Factory Mutual Approved: Report No. J.I.1V9A0.AF.
IRI Acceptable.
Federal Communications Commission: Part 15, Class B, Emissions.

Mounting:
Q7800A Wiring Subbase for panel mounting.
Q7800B Wiring Subbase for wall or burner mounting.

Required Components:
Plug-in Flame Signal Amplifier (See Table 4).
ST7800A Purge Timer (for RM7895E,F only).

Accessories:
Keyboard Display Modules (KDM):
S7800A1001 English language.
S7800A1035 French language.
S7800A1043 German language.
S7800A1050 Italian language.
S7800A1068 Spanish language.
S7800A1118 Katakana (Japanese) language.
S7800A1126 Portuguese language.
Communications:
Q7700A1014 Network Interface Unit, 120 Vac, 50/60 Hz applications, external modem required.

Q7700B1004 Network Interface Unit with universal 100 to 250 Vac, 50/60 Hz external power supply, external modem required.
 QS7800A1001 ControlBus Module, standard.
 QS7800B1000 ControlBus Module, multidrop.
 QS7850A1001 ControlBus Module, General Purpose Interface.
 ZM7850A1006 Combustion System Manager™ Software.
 S7810A1009 Data ControlBus™ Module (if no KDM used).
 S7810B1007 Data ControlBus™ Module, multi-drop switch module.
 S7810M1003 ModBus Module.

Miscellaneous:

A7800A1002 7800 SERIES Tester.
 S7820A1007 Remote Reset Module.
 S7830A1005 Expanded Annunciator, 120 Vac, 50/60 Hz.
 203541 Data ControlBus Connector, 5-wire.

203765 Remote Display Mounting Bracket.
 221729 Dust Cover, Relay Module.
 204718A Keyboard Display Module Cover, NEMA 4, clear.
 204718B Keyboard Display Module Cover, NEMA 1, clear.
 204718C Keyboard Display Module Cover, NEMA 4, clear with reset button.
 205321B Flush Display Mounting Kit.
 221818A Extension Cable, display, 5 ft (1.52 m).
 221818C Extension Cable, display, 10 ft (3.05 m).
 123514A Rectification Flame Simulator.
 203968A Remote Display Power Supply, 13 Vdc, plug-in.

IMPORTANT

A flame detection system is required for operation and must be ordered separately. Select the applicable flame signal amplifier and matching flame detector from Table 4.

Table 4. Flame Detection Systems.

Plug-in Flame Signal Amplifiers					Applicable Flame Detectors		
Type	Color	Self-Checking	Model	Flame Failure Response Time ^a	Fuel	Type	Models
Rectification	Green	No	R7847A	0.8 or 3 sec.	Gas	Rectifying Flame Rod Holders ^b	C7004, C7007, C7011. Complete Assemblies: C7008, C7009, Q179
		Dynamic AMPLI-CHECK™ Circuitry	R7847B ^c				
Infrared	Red	No	R7848A	3.0 sec.	Gas, Oil, Coal	Infrared (lead sulfide)	C7015
		Dynamic AMPLI-CHECK™	R7848B				
	Red/White	No	R7852A	3.0 sec.	Gas, Oil, Coal	Infrared	C7915
		Dynamic AMPLI-CHECK™	R7852B				
Optical	White	Dynamic AMPLI-CHECK™	R7851	0.8 or 3.0 sec	Oil, Coal	Optical (visible light or UV)	C7962, C7927

^a A 0.8 second flame failure response time amplifier is required when the relight option is selected for the RM7890 Relay Module (jumper JR2 is intact, see Table 6). The RM7890 locks out and indicates a Fault 46 if a 3.0 second flame failure response time amplifier is used and jumper JR2 is not clipped and removed.

^b Order flame rod separately, see holder instructions.

^c Circuitry tests the flame signal amplifier 12 times a minute during burner operation and shuts down the burner if the amplifier fails. This amplifier should be used on applications operated continuously greater than 24 hours.

Table 5. Sequence Timing for Normal Operation.

Device	Initiate	Standby ^a	Purge ^b	Pilot Flame Establishing Period	AFSC ^c	Run ^a
RM7890D	10 sec.	—	N/A	15 or 30 sec.	N/A	—
RM7895E	10 sec.	—	—	15 or 30 sec.	No	—
RM7895F	10 sec.	—	—	15 or 30 sec.	Yes	—

^a Standby and Run can be an infinite time period.

^b Purge is determined by the ST7800 Purge Timing Card selected (RM7895 only).

^c AFSC is Airflow Switch Check. Factory configured by model only.

PRINCIPAL TECHNICAL FEATURES

The RM7890D and RM7895E,F Relay Modules provide all customary flame safeguard functions while providing significant advancements in the areas of safety, annunciation and system diagnostics.

Safety Shutdown (Lockout) Occurs If:

1. INITIATE PERIOD
 - a. Ac line power errors occurred; see Operations section.
 - b. Configuration jumpers are changed after 200 hours of operation.
 - c. Four minute INITIATE period has been exceeded.
 - d. Purge card is not installed or was removed (RM7895 only).
 - e. Purge card is faulty.
2. STANDBY PERIOD
 - a. Flame signal is present after 240 seconds.
 - b. Ignition/intermittent pilot valve terminal is powered when it should be off.
 - c. Internal system fault occurred.
 - d. Main valve terminal is powered when it should be off.
 - e. Three-second flame failure response time (FFRT) amplifier is installed and configuration jumper is selected for relight (RM7890D); see Table 8.
 - f. Airflow switch check feature model is selected and the airflow switch is closed for 120 seconds with controller closed (RM7895F only). (Fails to open and reclose.)
 - g. Purge card is not installed or was removed (RM7895).
 - h. Purge card is faulty.
3. SAFE START CHECK
 - a. Ignition/intermittent pilot valve terminal is energized when it should be off.
 - b. Internal system fault occurred.
 - c. Main valve terminal is energized.
4. PREPURGE PERIOD (RM7895 Only). (Fails to open and reclose.)
 - a. Airflow lockout feature is enabled and the airflow switch does not close after ten seconds or within the specified purge card timing.
 - b. Flame signal is detected after 30 seconds.
 - c. Ignition/pilot valve/intermittent pilot valve terminal is energized when it should be off.
 - d. Main valve terminal is energized when it should be off.
 - e. Internal system fault occurred.
 - f. Purge card is not installed or was removed.
 - g. Purge card is faulty.
5. PILOT FLAME ESTABLISHING PERIOD (PFEP).
 - a. Ignition/intermittent pilot valve terminal is not energized.
 - b. Internal system fault occurred.
 - c. Main valve terminal is energized when it should be off.
 - d. No flame present at end of PFEP.
 - e. Airflow lockout feature is enabled and the airflow switch opens (RM7895).
 - f. Purge card is not installed or was removed (RM7895 only).
 - g. Purge card is faulty (RM7895 only).
6. RUN PERIOD.
 - a. Ignition terminal is energized when it should be off.
 - b. Internal system fault occurred.

- c. Main valve terminal is not energized when it should be on.
- d. No flame is present and configuration jumper is selected for lockout.
- e. Pilot valve terminal is not energized.
- f. Airflow lockout feature is enabled and the airflow switch opens (RM7895).
- g. Purge card is not installed or was removed (RM7895 only).
- h. Purge card is faulty (RM7895 only).

SAFETY PROVISIONS

Internal Hardware Status Monitoring

The RM7890D; RM7895E,F Relay Modules analyze the integrity of the configuration jumpers and internal hardware. The RM7895 checks the purge card for correct parity to prevent purge timing shifts and circuitry failures. The POWER LED will blink every four seconds, signifying an internal hardware check.

Closed Loop Logic Test

The test verifies the integrity of all safety critical loads, terminals 8, 9 and 10. If the loads are not energized properly—that is, the main valve terminal is powered during STANDBY—the relay module locks out on safety shutdown. The relay module must react to input changes but avoid the occurrence of nuisance shutdown events. Signal conditioning is applied to line voltage inputs to verify proper operation in the presence of normal electrical line noises such as transient high voltage spikes or short periods of line dropout. Signal conditioning is tolerant of synchronous noise (line noise events that occur at the same time during each line cycle).

Dynamic AMPLI-CHECK™ Circuitry

Dynamic AMPLI-CHECK™ circuitry tests the flame signal amplifier during burner operation and shuts down the relay module if the flame amplifier fails.

Dynamic Input Check

All system input circuits are examined to assure that the relay module is capable of recognizing the true status of external controls, limits and interlocks. If any input fails this test, a safety shutdown occurs and the fault will be annunciated.

Dynamic Safety Relay Test

Checks the ability of the dynamic safety relay contact to open and close. Verifies that the safety critical loads, terminals 8, 9 and 10 can be de-energized, as required, by the Dynamic Self-Check logic.

Dynamic Self-Check Safety Circuit

The microcomputer tests itself and related hardware, and at the same time, the safety relay system tests the microcomputer operation. If a microcomputer or safety relay failure occurs and does not allow proper execution of the self-check routine, safety shutdown occurs and all safety critical loads will be de-energized.

Expanded Safe-Start Check

The conventional safe-start check, which prevents burner startup when flame is indicated at startup, is expanded to include a flame signal check during STANDBY, an airflow switch check (RM7895F only), and a safety critical load check.

Off Cycle (Standby) Flame Signal Check

The flame detection subsystem (flame detector and amplifier) is monitored during STANDBY. If a flame simulating condition or an actual flame exists for 40 seconds in STANDBY, a system hold occurs and startup is prevented. If the flame signal exists at any time after the 40 seconds during STANDBY, a safety shutdown occurs and is annunciated. An AMPLI-CHECK™ Amplifier is energized continually through STANDBY (and PREPURGE in the RM7895) to detect any possibility of a runaway detector or a flame. When a flame exists, a safety shutdown occurs. A standard amplifier is energized continually through STANDBY (and PREPURGE in the RM7895). When a flame exists, a safety shutdown occurs.

Tamper Resistant Timing and Logic

Safety and logic timings are inaccessible and cannot be altered or defeated.

Verified Spark Termination

The ignition terminal is monitored to assure early spark termination (ten seconds ignition and pilot and ten seconds pilot and main only).

First-Out Annunciation and Self-Diagnostics

Sequence Status Lights (LED) provide positive visual indication of the program sequence: POWER, PILOT, FLAME, MAIN and ALARM. The green POWER LED blinks every four seconds, signifying that the relay module hardware is running correctly.

The optional multi-functional KDM shows elapsed time during PILOT IGN. As an additional troubleshooting aid, it provides sequence timing, diagnostic information, historical information and expanded annunciator information during normal operation or when a safety shutdown or hold occurs.

First-out Annunciation reports the cause of safety shutdown or identifies the cause of a failure to start or continue the burner control sequence with an English text and numbered code via the optional KDM. It monitors all field input circuits, including the flame signal amplifier. The system distinguishes 39 modes of failure (43 modes in the RM7895) and detects and annunciates difficult-to-find intermittent failures. See the S7830 Expanded Annunciator (form 65-0101) for more information.

Self-Diagnostics add to the First-Out Annunciation by allowing the relay module to distinguish between field (external device) and internal (system related) problems. Faults associated

within the flame detection subsystem or relay module are isolated and reported by the optional KDM. See the 7800 SERIES Relay Modules Checkout and Troubleshooting, form 65-0229.

Interlock Requirements (RM7895 Only)

The Airflow Switch Interlock input provided in the RM7895 is described in the next paragraph.

Airflow Switch Interlock

This interlock is typically connected to an airflow switch. The Airflow Interlock (ILK) input must close ten seconds into PREPURGE or within the specified purge card timing; otherwise, a recycle to the beginning of PREPURGE or lockout occurs, depending on how the airflow switch selectable jumper is configured (see Table 5 in the Operation section). The RM7895F has a dynamic airflow switch safe-start check feature. If the control input terminal 6 is energized and the airflow switch is closed during STANDBY, the RM7895F will lock out after 120 seconds.

INSTALLATION

WARNING

Fire or Explosion Hazard.

Can cause severe injury, death or property damage.

To prevent possible hazardous burner operation, verify local safety requirements are observed each time a control is installed on a burner.

WARNING

Electrical Shock Hazard or Equipment Damage Hazard.

Can cause severe injury, death or equipment and control damage.

Disconnect the power supply before beginning installation.

When Installing this Product...

1. Read these instructions carefully. Failure to follow them could damage the product or cause a hazardous condition.
2. Check the ratings given in the instructions and marked on the product to make sure the product is suitable for the application.
3. Installer must be a trained, experienced, flame safeguard service technician.
4. After installation is complete, check out the product operation as provided in these instructions.

IMPORTANT

1. *Wiring connections for the relay modules are unique; refer to Fig. 6 and 7 or the correct Specifications for proper subbase wiring.*
2. *Wiring must comply with all applicable codes, ordinances and regulations.*
3. *Wiring must comply with NEC Class 1 (Line Voltage) wiring.*
4. *Loads connected to the relay module must not exceed those listed on the relay module label or the Specifications; see Table 1.*
5. *Limits and interlocks must be rated to simultaneously carry and break current to the ignition transformer, pilot valve, and main fuel valve(s).*
6. *All external timers must be Listed or Component-Recognized by authorities who have proper jurisdiction.*
7. *For on-off gas-fired systems, some authorities who have jurisdiction prohibit the wiring of any limit or operating contacts in series between the flame safeguard control and the main fuel valve(s).*
8. *Two flame detectors can be connected in parallel.*
9. *This equipment generates, uses and can radiate radio frequency energy and, if not installed and used in accordance with the instructions, can cause interference with radio communications. It has been tested and found to comply with the limits for a Class B computing device of Part 15 of FCC rules which are designed to provide reasonable protection against such interference when operated in a commercial environment. Operation of this equipment in a residential area may cause interference; in which case, the users at their own expense may be required to take whatever measures are required to correct this interference.*
10. *This digital apparatus does not exceed the Class B limits for radio noise for digital apparatus set out in the Radio Interference Regulations of the Canadian Department of Communications.*

Location

Humidity

Install the relay module where the relative humidity never reaches the saturation point. The relay module is designed to operate in a maximum 85% relative humidity continuous, noncondensing, moisture environment. Condensing moisture can cause a safety shutdown.

Vibration

Do not install the relay module where it could be subjected to vibration in excess of 0.5G continuous maximum vibration.

Weather

The relay module is not designed to be weather tight. When installed outdoors, locate the relay module inside an approved weather-tight enclosure.

Mounting Wiring Subbase

See Fig. 1 and 2 for installation dimensions.

1. Mount the subbase in any position except horizontally with the bifurcated contacts pointing down. The standard vertical position is recommended. Any other position decreases the maximum ambient temperature rating.
2. Select a location on a wall, burner or electrical panel. The Q7800 can be mounted directly in the control cabinet. Be sure to allow adequate clearance for servicing, installation, access or removal of the relay module, expanded annunciator, KDM, flame amplifier, flame amplifier signal voltage probes, run/test switch, electrical signal voltage probes and electrical field connections.
3. For surface mounting, use the back of the subbase as a template to mark the four screw locations. Drill the pilot holes.
4. Securely mount the subbase using four no. 6 screws (not provided).

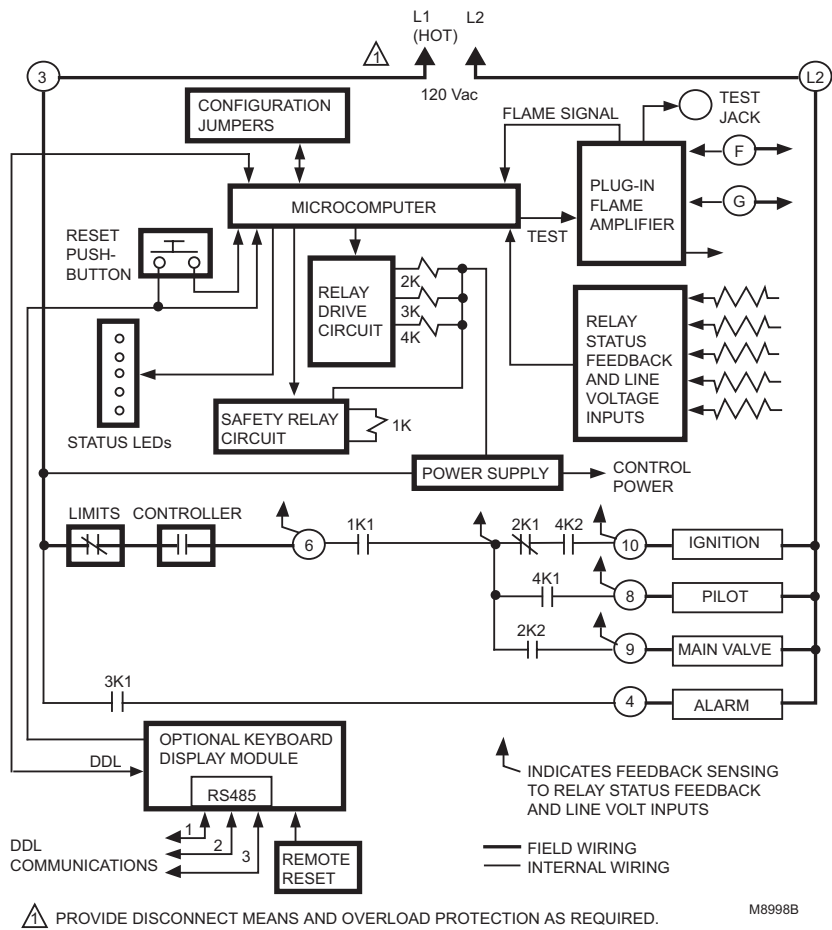

Fig. 3. Internal block diagram of the RM7890 (see Fig. 5 for detailed wiring instructions).

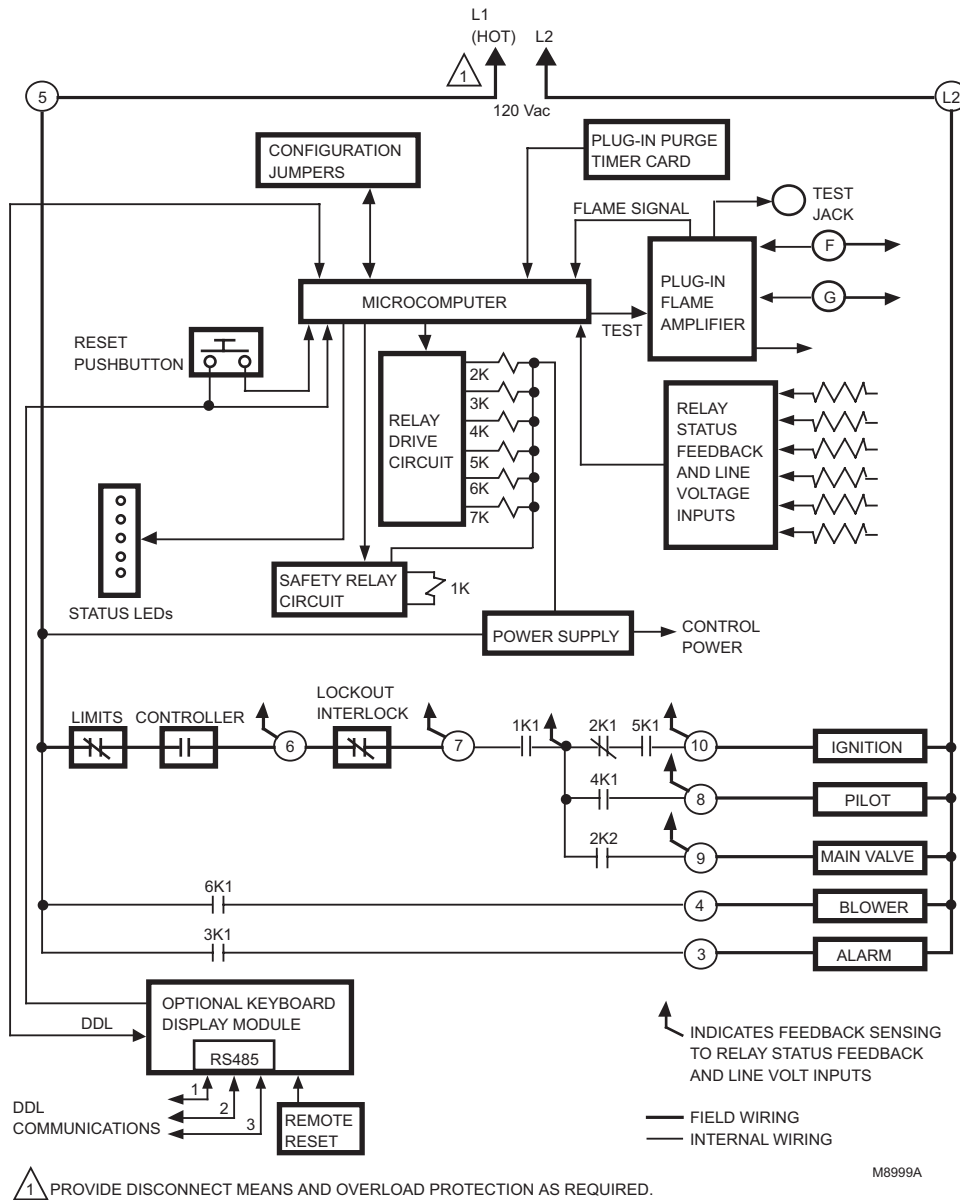

Fig. 4. Internal block diagram of the RM7895 Relay Module (see Fig. 6 for detailed wiring instructions).

WIRING

⚠ WARNING

Electrical Shock Hazard or Equipment and Control Damage Hazard.

Can cause severe injury, death or equipment and control damage.

Disconnect the power supply before beginning installation.

1. For proper subbase wiring, refer to Fig. 5 and 6.

2. For proper remote wiring of the KDM, refer to the Specifications for the KDM (65-0090), Network Interface Unit (63-2278), Data ControlBus™ Module (65-0091) or Extension Cable Assembly (65-0131).
3. Disconnect the power supply from the main disconnect before beginning installation to prevent electrical shock and equipment damage. More than one disconnect may be required.
4. All wiring must comply with all applicable electrical codes, ordinances and regulations. Wiring, where required, must comply with NEC, Class 1 (Line Voltage) wiring.
5. Recommended wire size and type: See Table 6 for the recommended wire sizes and part numbers.

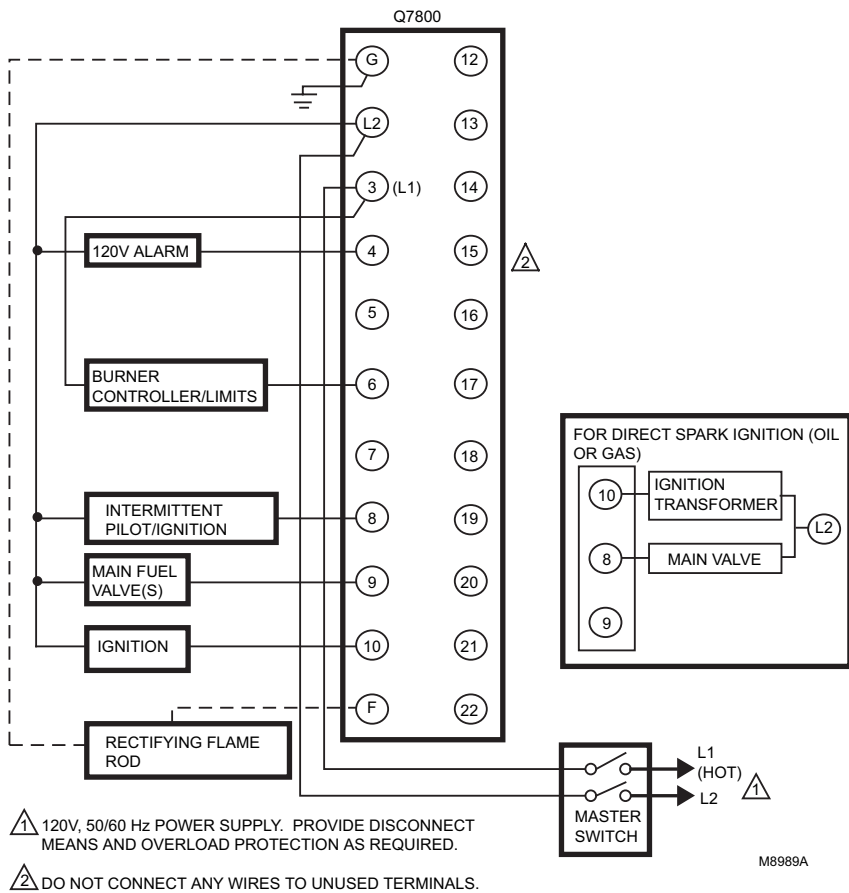

Fig. 5. Wiring the RM7890D Relay Module.

Table 6. Recommended Wire Sizes and Part Numbers.

Application	Recommended Wire Size	Recommended Part Numbers
Line voltage terminals	14, 16 or 18 AWG copper conductor, 600 volt insulation, moisture-resistant wiring.	TTW60C, THW75C, THHN90C.
KDM	22 AWG two-wire twisted pair with ground, or five-wire communications wire.	Belden® 8723 shielded cable (two-wire) or Belden® 8771 shielded cable (five-wire) or equivalent.
Data ControlBus™ Module	22 AWG two-wire twisted pair with ground or five-wire communications wire.	Belden® 8723 shielded cable (two-wire) or Belden® 8771 shielded cable (five-wire) or equivalent.
Remote Reset Module	22 AWG two-wire twisted pair, insulated for low voltage.	—
Communications Interface ControlBus™ Module	22 AWG two-wire twisted pair with ground.	Belden® 8723 shielded cable or equivalent.
13 Vdc full-wave rectified transformer power input	18 AWG wire insulated for voltages and temperatures for given application.	TTW60C, THW75C, THHN90C.

The KDM, Data ControlBus™ Module (for remote mounting or communications) or Communications Interface ControlBus™ Module must be wired in a daisy chain configuration, (1(a)-1(a), 2(b)-2(b), 3(c)-3(c)). The order of interconnection of all the devices listed above is not important. Be aware that

modules on the closest and farthest end of the daisy chain configuration string require a 120 ohm (1/4 watt minimum) resistor termination across terminals 1 and 2 of the electrical connectors for connections longer than 100 feet (30 meters).

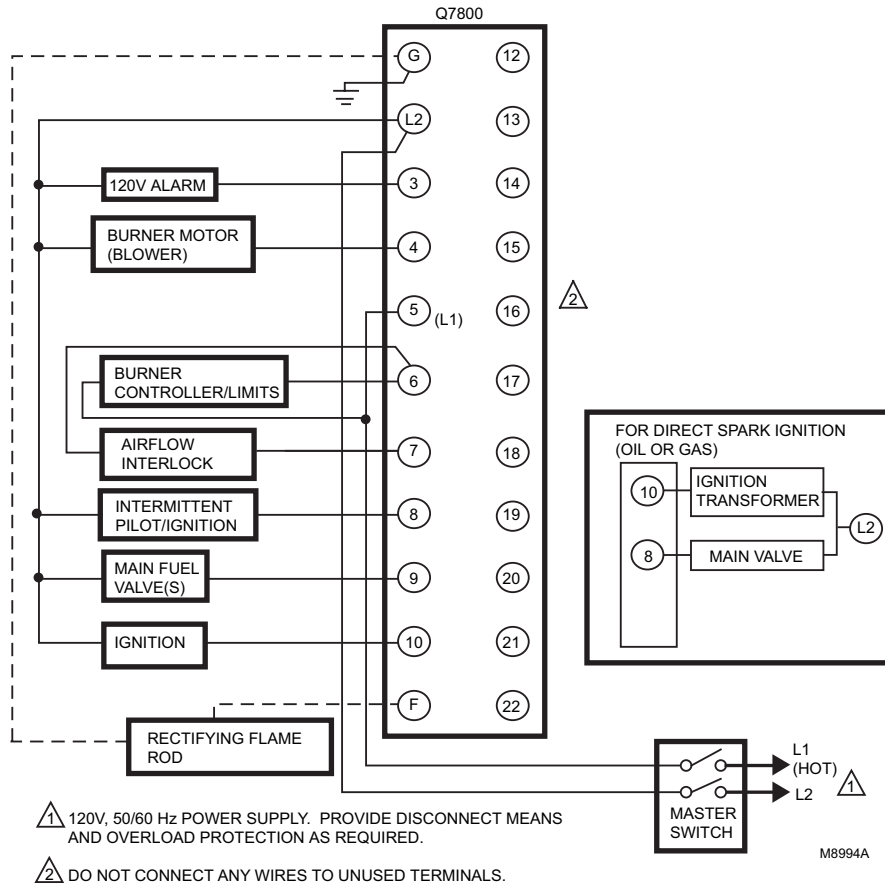

Fig. 6. Wiring the RM7895E,F Relay Module.

6. For recommended grounding practices, see Table 7.

Table 7. Recommended Grounding Practices.

Ground Type	Recommended Practice
Earth ground (subbase and relay module).	<ol style="list-style-type: none"> 1. Use to provide a connection between the subbase and the control panel of the equipment. Earth ground must be capable of conducting enough current to blow the 15A fuse (or breaker) in the event of an internal short circuit. 2. Use wide straps or brackets to provide minimum length, maximum surface area ground conductors. If a lead wire must be used, use 14 AWG copper wire. 3. Make sure that mechanically tightened joints along the ground path are free of nonconductive coatings and protected against corrosion on mating surfaces.
Signal ground (KDM, Data ControlBus™ Module, Communications Interface ControlBus™ Module)	Connect the shield at both ends of the daisy chain to earth ground.

7. Recommended wire routing:

a. For flame detector leadwires:

- (1) Do not run high voltage ignition transformer wires in the same conduit with the flame detection wiring.
- (2) Do not run scanner wires in a conduit with line voltage circuits.
- (3) Enclose scanner wires without armor cable in metal cable or conduit.
- (4) Follow directions given in the flame detector

instructions.

b. Data ControlBus™ Module:

- (1) Do not run high voltage ignition transformer wires in the same conduit with, or in close proximity to, the Data ControlBus™ Module wiring.
- (2) Do not route Data ControlBus™ Module wires in conduit with line voltage circuits.

- c. KDM: The KDM is powered from a low voltage, energy-limited source, so it can be mounted outside of the control panel if it is protected from mechanical damage.

NOTE: Use a separate 13 Vdc power supply any time more than two Data ControlBus™ Modules or KDM are used or when placed more than 100 feet (30 meters) from the relay module.

- d. Remote Reset Module:
 - (1) Do not run high voltage ignition transformer wires in the same conduit with the Remote Reset Module wiring.
 - (2) Do not route Remote Reset Module wires in conduit with line voltage circuits.

NOTE: Use a 13 Vdc power supply anytime more than one KDM is used.

- 8. Maximum wire lengths:
 - a. For the relay module, the maximum length of leadwire to the control terminal input is 300 feet (91 meters).
 - b. For the flame detector leadwires, the maximum flame sensor leadwire length is limited by the flame signal strength.
 - c. Remote Reset Module leadwires: The maximum length of wire is 1000 feet (305 meters) to a Remote Reset Module pushbutton.
 - d. Data ControlBus™ Module: The maximum Data ControlBus™ Module cable length depends on the number of system modules connected, the noise conditions, and the cable used. The maximum length of all interconnecting wires is 1000 feet (305 meters).
- 9. Make sure loads do not exceed the terminal ratings. Refer to the label on the relay module or to the ratings in the Specifications section. See Table 1.
- 10. Check the power supply circuit to be sure the voltage and frequency tolerance match those of the relay module. A separate power supply circuit can be required for the relay module with the required disconnect means and overload protection added.
- 11. Check all wiring circuits and complete the Static Checkout, see Table 8, before installing the relay module on the wiring subbase.
- 12. Install all electrical connectors.
- 13. Restore power to the panel.

ASSEMBLY

Mounting RM7890D; RM7895E,F

NOTE: For installation dimensions, see Fig. 1 or 2.

Relay Module Mounting

1. Mount the relay module vertically, see Fig. 7 or 8, or mount horizontally with the knife blade terminals pointing downward. When mounting on the Q7800A Wiring Subbase, the relay module must be in an electrical enclosure.
2. Select the location in the electrical enclosure. Be sure to allow adequate clearance for servicing, installation and removal of the relay module, dust cover, flame amplifier, flame amplifier signal voltage probes, electrical signal voltage probes and electrical connections.
 - a. Allow an additional two inches (51 mm) below the relay module for the flame amplifier mounting.
 - b. Allow an optional three-inch (76 mm) minimum to both sides of the relay module for electrical signal voltage probes.
3. Make sure subbase wiring does not project beyond the terminal blocks. Tuck in wiring against the back of the subbase so it does not interfere with the knife blade terminals or bifurcated contacts.

IMPORTANT

The relay module must be installed with a plug-in motion rather than a hinge action.

4. Mount the relay module by aligning the four L-shaped corner guides and knife blade terminals with the bifurcated contacts on the wiring subbase and securely tightening the two screws without deforming the plastic.

Dust Cover Mounting

1. Align the interlocking ears of the dust cover with the two mating slots in the relay module, see Fig. 9.
2. Insert the two interlocking ears into the two mating slots, and with a hinge action, push on the upper corners of the dust cover to secure it to the relay module.
3. Be sure the dust cover is firmly in place.

Installing ST7800 Purge Card (RM7895 Only)

1. Remove the dust cover, KDM, Data ControlBus™ Module, or extension cable assembly.
2. Remove the current ST7800 Purge Card from the relay module by pulling upward on the plastic support cover. See Fig. 10.
3. Make sure that the ST7800 Purge Card selected has the desired purge timing.
4. Insert the ST7800 Purge Card into the opening of the relay module purge card compartment. See Fig. 10.

Installing Plug-In Flame Signal Amplifier

1. Disconnect the power supply before beginning installation to prevent electrical shock and equipment damage. More than one disconnect can be involved.
2. Align the amplifier circuit board edge connector with the keyed receptacle on the relay module. Verify that the amplifier nameplate faces away from the relay module. See Fig. 11.
3. Push in the amplifier until the circuit board is fully inserted into the receptacle and then push the amplifier toward the relay module retaining clasp.
4. Verify the amplifier is firmly in place.
5. Perform all required checkout tests.

Installing Flame Detector

NOTE: See Table 4 for the flame detection system available for use with the relay module. Make sure the correct combination of amplifier and flame detector is used.

Proper flame detector installation is the basis of a safe and reliable flame safeguard installation. Refer to the instructions packed with the flame detector and the equipment manufacturer instructions.

Keep the flame signal leadwires as short as possible from the flame detector to the wiring subbase. Capacitance increases with leadwire length, reducing the signal strength. The maximum permissible leadwire length depends on the type of flame detector, leadwire and conduit. The ultimate limiting factor in the flame detector leadwire is the flame signal. See Table 10.



Fig. 9. Dust cover mounting.



Fig. 7. Electrical panel installation.

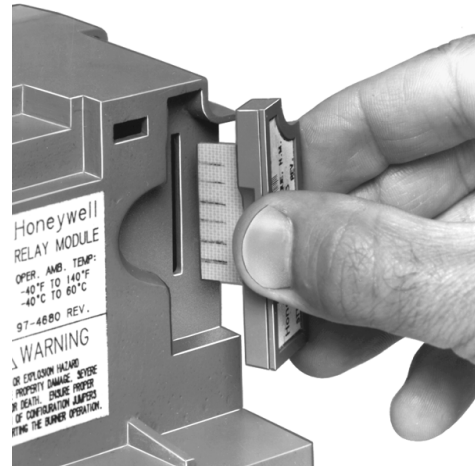

Fig. 10. ST7800 Purge Card installation (RM7895 only).



Fig. 8. Wall or burner installation.



Fig. 11. Flame signal amplifier mounting.

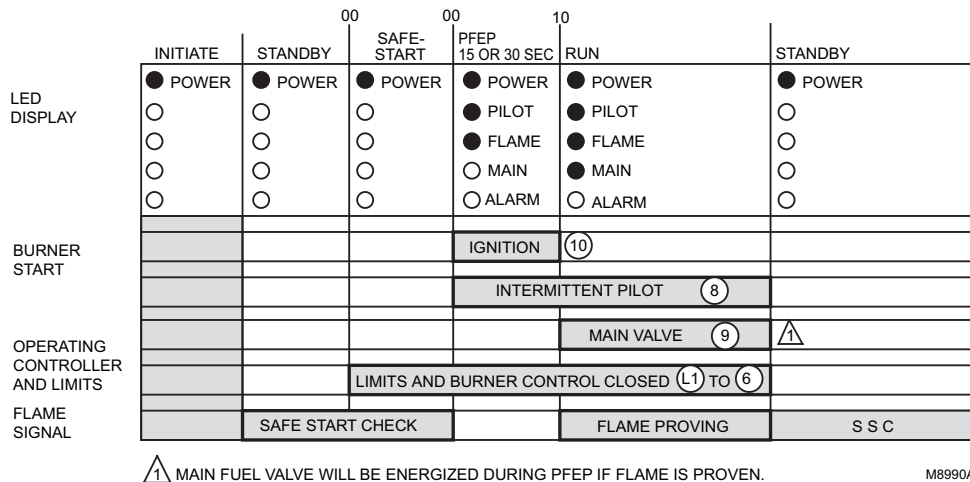

Fig. 12. RM7890D sequence.

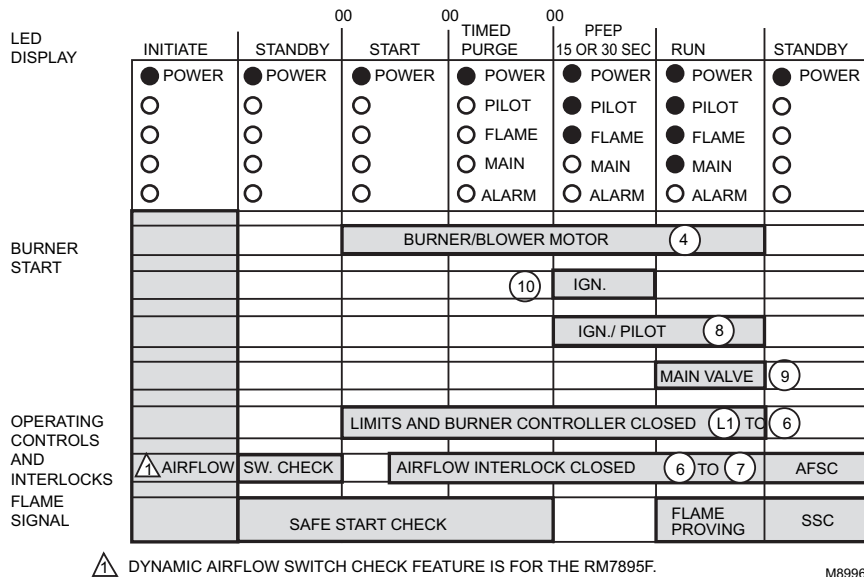

Fig. 13. RM7895E,F sequence.

OPERATION

Sequence of Operation

The relay modules have operating sequences as shown in Fig. 12 through 14.

INITIATE

The relay module enters the INITIATE sequence if the relay module verifies voltage fluctuations of +10%/-15% or frequency fluctuations of ±10% during any part of the operating sequence. The INITIATE sequence lasts for ten seconds unless the voltage or frequency tolerances are not met. When the tolerances are not met, a hold condition is initiated and displayed on the optional KDM for at least five seconds. When the tolerances are met, the INITIATE sequence restarts. If the

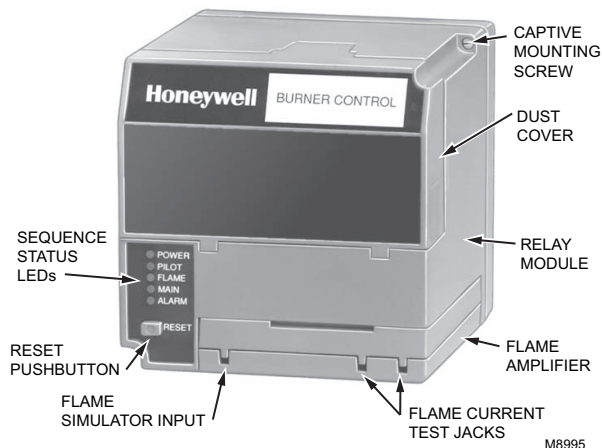

Fig. 14. Sequence status LED.

condition is not corrected and the hold condition exists for four minutes, the relay module locks out. Causes for hold conditions in the INITIATE sequence are:

1. Ac line dropout is detected.
2. Ac line frequency error.
3. Ac line noise occurred that prevents a sufficient reading of the line voltage inputs.
4. Brownout occurred caused by a low line voltage.

The INITIATE sequence also delays the burner motor starter from being energized and de-energized from an intermittent ac line input or control input.

STANDBY

The relay module is ready to start an operating sequence when the operating control input determines a call for heat is present. The burner switch, limits, operating limit control and all microcomputer monitored circuits must be in the correct state for the relay module to continue into the SAFE-START CHECK (RM7890) or the PREPURGE (RM7895) sequence.

Normal Startup

Safe-Start Check

The RM7890D, RM7895E,F verify that a flame does not exist and proceeds into the Ignition Trial. If a flame is present, the relay module recycles to the STANDBY period. If the critical loads are not in the correct state, a safety shutdown occurs.

Prepurge (RM7895)

The RM7895E,F provides a selectable PREPURGE timing from two seconds to thirty minutes (using the ST7800 Plug-in Purge Timer) with power applied and the RM7895E,F operating control indicating a call for heat.

1. Airflow Interlock, burner switch and all microcomputer monitored circuits must be in the correct operating state.
2. The blower motor output, terminal 4, is powered to start the PREPURGE sequence.
3. The Airflow Interlock input must close ten seconds into PREPURGE or within the specified purge card timing; otherwise, a recycle to the beginning of PREPURGE or lockout occurs depending on how the airflow switch selectable jumper is configured.

Ignition Trials

Pilot Flame Establishing Period (PFEP):

1. The pilot valve and ignition transformer, terminals 8 and 10, are energized. The relay module has an intermittent pilot valve, terminal 8.
2. Flame must be proven by the end of the 15- or 30-second PFEP to allow the sequence to continue. If flame is not proven by the end of PFEP, a safety shutdown occurs. For the RM7890 only: if the flame is established within the PFEP, the system immediately goes to the RUN state.
3. With flame proven (RM7895 reaches the end of the PFEP), the ignition, terminal 10, is de-energized and the main valve, terminal 9, is energized.

Run

The relay module is now in RUN and remains in RUN until terminal 6, the controller input, opens, indicating that the call for heat demand is satisfied or that a limit has opened.

Selectable Site-Configurable Jumpers

The RM7890D has two site-configurable jumper options and the RM7895E,F has three. See Fig. 15 and 16 and Tables 8 and 9. The site-configurable jumpers should be clipped with side cutters and the resistors removed from the relay module.

SERVICE NOTE: For RM7890 when using a 3-second amplifier, clip and remove site-configurable jumper JR2. If not removed, an F46 Lockout occurs.

IMPORTANT

Clipping jumpers after 200 hours of operation will result in a hard lockout (Fault Code 110).

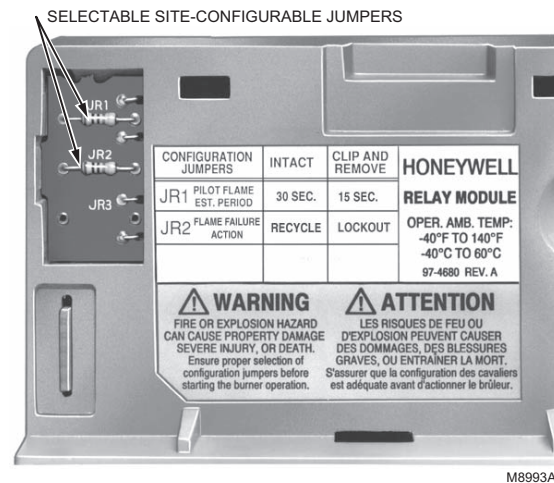

Fig. 15. Selectable site-configurable jumpers (RM7890).

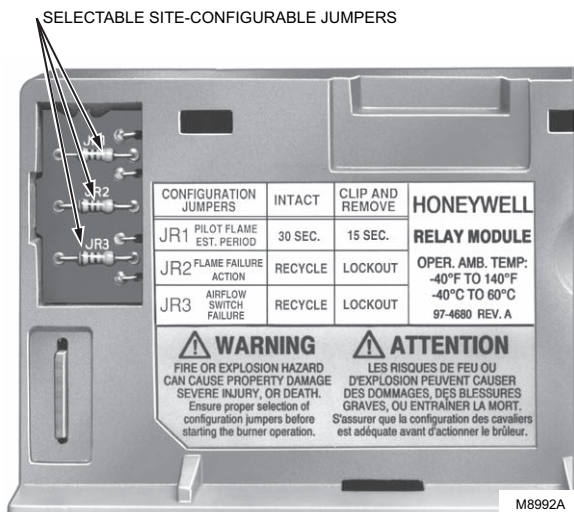

Fig. 16. Selectable site-configurable jumpers (RM7895).

Table 8. Site-Configurable Jumper Options (RM7890).

Jumper Number	Description	Intact	Clipped
JR1	Pilot Flame Establishing Period	30 seconds	15 seconds
JR2	Flame Failure Action	Relight ^a	Lockout

^aThe Relight feature (JR2) requires a 0.8 second FFRT flame amplifier.

Table 9. Site-Configurable Jumper Options (RM7895).

Jumper Number	Description	Intact	Clipped	RM7895 Type
JR1	Pilot Flame Establishing Period	30 seconds	15 seconds	All
JR2	Flame Failure Action	Recycle	Lockout	All
JR3	Airflow Switch (ILK) Failure	Recycle	Lockout	F Only

STATIC CHECKOUT

WARNING

Electrical Shock Hazard.
Can cause severe injury, death or property damage.
 Open the master switch before installing or removing a jumper on the wiring subbase.

1. Use extreme care when testing the system because line voltage is present on most terminal connections when power is on.
2. Before continuing to the next test, be sure to remove the test jumper(s) used in the previous test.
3. Replace all limits and interlocks not operating properly. Do not bypass limits and interlocks.
4. Close all manual fuel shutoff valves before starting the tests.

After checking all wiring, perform this checkout before installing the relay module on the wiring subbase. These tests verify that the Q7800 Wiring Subbase is wired correctly and that the external controllers, limits, interlocks, actuators, valves, transformers, motors and other devices are operating properly.

CAUTION

Equipment Damage Hazard.
High voltage dielectric test can cause equipment damage.
 Do not perform dielectric test with the relay module installed. Internal surge protectors break down and conduct a current, causing dielectric test failure and destruction of the internal lightning and high current protection.

Equipment Recommended



1. Voltmeter (one megohm/volt minimum sensitivity), set on the 0 to 300 Vac scale.
2. Two jumper wires, no. 14 wire, insulated, 12 in. (305 mm) long with insulated alligator clips at both ends.

General Instructions

1. Perform all applicable tests listed in Static Checkout, Tables 10 and 11, in the order listed.
2. Make sure that all manual fuel shutoff valves are closed.
3. Perform only those tests designated for the specific relay module model being tested.



4. Raise the setpoint of the operating controller to simulate a call for heat.
5. For each test, open the master switch and install the jumper wire(s) between the subbase wiring terminals listed in the Test Jumpers column of Table 10 or Table 11.
6. Close the master switch before observing operation.
7. Read the voltage between the subbase wiring terminals listed in the Voltmeter column of Table 10 or 11.
8. If there is no voltage or the operation is abnormal, check the circuits and external devices as described in the last column.
9. Check all wiring for correct connections, tight terminal screws, correct wire size, and proper wiring techniques. Replace all damaged or incorrectly sized wires.
10. Replace faulty controllers, limits, interlocks, actuators, valves, transformers, motors and other devices as required.
11. Obtain normal operation for each required test before continuing the checkout.
12. After completing each test, be sure to remove the test jumper(s).

Table 10. RM7890 Static Checkout.

Test Number	Test Jumpers	Voltmeter	Normal Operation	If Operation is Abnormal, Check the Items Listed Below
 WARNING Explosion Hazard. Can cause severe injury, death or property damage. Make sure that all manual fuel shutoff valves are closed.				
IMPORTANT Low fuel pressure limits, if used, could be open. Bypass them with jumpers for the remaining static tests, if required.				
1	None	3 to L2	Line voltage at terminal 3.	1. Master Switch. 2. Power connected to the Master Switch. 3. Overload protection (fuse, circuit breaker) has not opened the power line.
2	None	6 to L2	Line voltage at terminal 6.	1. Limits. 2. Burner controller.
3	3 to 10 ^a	—	Ignition spark (if ignition transformer is connected to terminal 10).	1. Watch for spark or listen for buzz. a. Ignition electrodes are clean. b. Ignition transformer is okay.
4	3 to 8 ^a	—	1. Ignition spark (if ignition transformer is connected to terminal 8). 2. Automatic pilot valve opens (if connected to terminal 8). NOTE: Refer to wiring diagram of system being tested.	1. Watch for spark or listen for buzz. a. Ignition electrodes are clean. b. Ignition transformer is okay. 2. List for click or feel head of valve for activation. a. Actuator, if used. b. Pilot valve.
5	3 to 9 ^a	—	Automatic fuel valve(s) opens. If using direct spark ignition, check the first stage fuel valve(s) instead of the pilot valve.	Same as test number 4. If using direct spark ignition, check the first stage fuel valve(s) instead of the pilot valve.
6	3 to 4	—	Alarm, if used, turns on.	Alarm.
Final	 CAUTION Equipment Damage Hazard. Incorrect wiring can damage equipment. After completing these tests, open the Master Switch and remove <i>all</i> test jumpers from the subbase terminals. Also remove the bypass jumpers from the low fuel pressure limits (if used).			

^a Use an ammeter in place of the jumper wire to verify current draw of the terminal loads. Do not exceed ratings shown in Tables 2 and 3.

Table 11. RM7895 Static Checkout.

Test Number	Test Jumpers	Voltmeter	Normal Operation	If Operation is Abnormal, Check the Items Listed Below
 WARNING Explosion Hazard. Can cause severe injury, death or property damage. Make sure that all manual fuel shutoff valves are closed. IMPORTANT <i>Low pressure fuel limits, if used, could be open. Bypass them with jumpers for the remaining static tests, if required.</i>				
1	None	5 to L2	Line voltage at terminal 3.	<ol style="list-style-type: none"> Master Switch. Power connected to the Master Switch. Overload protection (fuse, circuit breaker) has not opened the power line.
2	None	6 to L2	Line voltage at terminal 6.	<ol style="list-style-type: none"> Limits. Burner controller.
3	4 to 5	7 to L2	Burner motor (fan or blower) starts. Line voltage at terminal 7 within 10 seconds.	<ol style="list-style-type: none"> Burner motor circuit. <ol style="list-style-type: none"> Manual switch of burner motor. Burner motor power supply, overload protection and starter. Burner motor.
4	5 to 10	—	Ignition spark (if ignition transformer is connected to terminal 10).	<ol style="list-style-type: none"> Watch for spark or listen for buzz. <ol style="list-style-type: none"> Ignition electrodes are clean. Ignition transformer is okay.
5	5 to 8	—	<ol style="list-style-type: none"> Ignition spark (if ignition transformer is connected to terminal 8). Automatic pilot valve opens (if connected to terminal 8). NOTE: Refer to wiring diagram of system being tested.	<ol style="list-style-type: none"> Watch for spark or listen for buzz. <ol style="list-style-type: none"> Ignition electrodes are clean. Ignition transformer is okay. List for click or feel head of valve for activation. <ol style="list-style-type: none"> Actuator, if used. Pilot valve.
6	5 to 9	—	Automatic fuel valve(s) opens. If using direct spark ignition, check the first stage fuel valve(s) instead of the pilot valve.	Same as test number 5. If using direct spark ignition, check the first stage fuel valve(s) instead of the pilot valve.
7	5 to 3	—	Alarm, if used, turns on.	Alarm.
Final	 CAUTION Equipment Damage Hazard. Incorrect wiring can damage equipment. After completing these tests, open the Master Switch and remove <i>all</i> test jumpers from the subbase terminals. Also remove the bypass jumpers from the low fuel pressure limits (if used).			

CHECKOUT

WARNING

Explosion Hazard.
Can cause severe injury, death or property damage.
 Do not allow fuel to accumulate in the combustion chamber. If fuel is allowed to enter the chamber for longer than a few seconds, an explosive mixture could result.

Limit the trial for pilot to ten seconds, and limit the attempt to light the main burner to two seconds from the time the fuel reaches the burner nozzle. Do not exceed the nominal lightoff time specified by the equipment manufacturer. Close the manual fuel shutoff valve(s) if the flame is not burning at the end of the specified time.

WARNING

Electrical Shock Hazard.
Can cause severe injury, death or property damage.
 Use extreme care while testing the system. Line voltage is present on most terminal connections when power is on.

1. Open the master switch before removing or installing the relay module.
2. Make sure all manual fuel shutoff valve(s) are closed before starting the initial lightoff check and the Pilot Turn-down tests.
3. Do not put the system into service until you have satisfactorily completed all applicable tests in this section and any others required by the equipment manufacturer.

4. Initial lightoff check for direct spark ignition (DSI) of oil, all burners using DSI.
5. Pilot turndown test, all installations using a pilot.
6. Hot refractory hold-in test, all installations.
7. Ignition interference test, all installations using flame rods.
8. Flame signal with hot combustion chamber, all installations.
9. Safety shutdown tests, all installations.

CAUTION

Equipment Damage Hazard.
Use of improper equipment will cause operational failure.

Do not replace the RM7890, RM7895 Relay Module with a lower or higher functioning relay module until you have made the necessary wiring changes or the burner will not sequence.

IMPORTANT

1. If the system fails to function properly, refer to 7800 SERIES Relay Modules Checkout and Troubleshooting, form 65-0229.
2. Repeat all required CHECKOUT tests after all adjustments are made. All tests must be satisfied with the flame detector in its final position.

Equipment Recommended

Volt ohmmeter (one megohm/volt minimum sensitivity):

- a. 0 to 300 Vac range.
- b. 0 to 6000 ohms range.
- c. 0 to 10 Vdc range.

Checkout Summary

1. Preliminary inspection, all installations.
2. Flame signal measurement, all installations.
3. Initial lightoff check for proved pilot, all installations using a pilot.

Preliminary Inspection

When performing the following inspections, check to verify:

1. Wiring connections are correct and all terminal screws are tight.
2. Flame detector is clean, installed and positioned properly. (Check the applicable installation instructions.)
3. Correct combination of amplifier and flame detector is used. See Table 4.
4. Plug-in amplifier is securely in place.
5. Burner is completely installed and ready to fire. (Consult equipment manufacturer instructions.)
6. Fuel lines are purged of air.
7. Combustion chamber and flues are clear of fuel and fuel vapors.
8. Power is connected to the system disconnect switch (master switch).
9. Lockout switch is reset (push in reset pushbutton) only if the relay module is powered; see Fig. 14.
10. System is in the STANDBY condition and POWER LED is energized.
11. All limits and interlocks are reset.

Flame Signal Measurement

Measure the flame signal at the appropriate times defined in the following checkout tests. Read the flame signal volts dc at the flame amplifier test jacks + and - (Com). See Fig. 17 and Table 12.

Table 12. Flame Signal.

Flame Detector	Flame Signal Amplifier	Minimum Acceptable Steady dc Voltage ^a	Maximum Expected dc Voltage
Flame Rod	R7847A,B ^b	1.25 Vdc	5.0 Vdc at the KDM or 5.0 Vdc at a one megohm per volt meter.
Infrared	R7848A,B R7852A,B	1.25 Vdc	5.0 Vdc at the KDM or 5.0 Vdc at a one megohm per volt meter.
Optical	R7851B	1.25 Vdc	5.0 Vdc at the KDM or 5.0 Vdc at a one megohm per volt meter.

^a This minimum or a stronger signal should be easily obtained if the detector is installed correctly and positioned to properly sense the flame. This voltage must be obtained before completing checkout.

^b The flame amplifiers are AMPLI-CHECK™ Circuitry type.

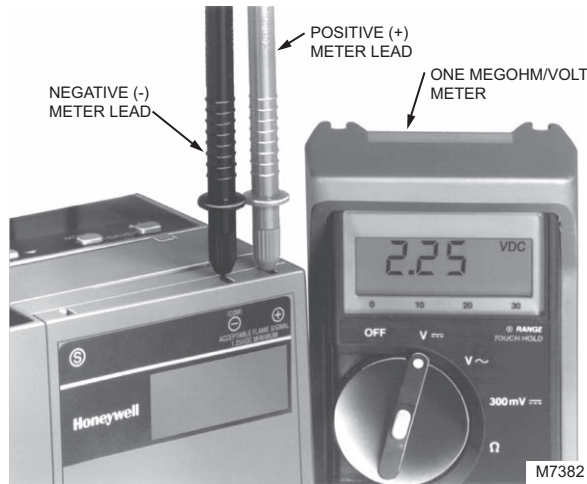

Fig. 17. Flame signal measurement.

1. Use a one megohm per volt meter with a 0 to 10 Vdc capability.
 2. Set the one megohm per volt meter to the 0 to 10 Vdc range.
 3. Insert the positive (red) probe into the + jack of the flame amplifier and the negative (black) probe into the - (Com) jack of the flame amplifier (see Fig. 17).
 4. Allow a few seconds for the meter reading to stabilize.
 5. If using AMPLI-CHECK™ or shutter check amplifiers, read the average stable voltage, disregarding the peaks and valleys caused by the self-checking operation.
 6. The meter reading must be as specified in Table 10 after all tests are made and all adjustments are made.
- As an option, check the flame signal by using the optional KDM.

If the signal is unstable or less than the minimum acceptable voltage, check the flame detector installation and circuitry.

1. Check the supply voltages at terminals 3 (L1) and L2 (N) for the RM7890 and terminals 5 (L1) and L2 (N) for the RM7895. Make sure the master switch is closed, connections are correct and the power supply is of the correct voltage, frequency and is sinusoidal.
2. Check the detector wiring for defects:
 - a. Deteriorated wiring.
 - b. Incorrect connections.
 - c. Leakage paths caused by moisture, soot or accumulated dirt.
 - d. Open circuits.
 - e. Short circuits.
 - f. Wrong type of wire.
3. For a flame rod, make sure:
 - a. Flame rod is properly located in the flame.
 - b. Ground area is large enough.
 - c. Temperature at the flame rod insulator is no greater than 500°F (260°C).
4. Make sure that the flame adjustment is not too lean.
5. If necessary, reposition the flame detector.

Initial Lightoff Check for Proved Pilot

Perform this check immediately following the preliminary inspection on all installations that use a pilot:

NOTE: Low fuel pressure limits, if used, could be open; if so, bypass with jumpers during this check.

1. Open the master switch.
2. Make sure the manual main fuel shutoff valve(s) is closed.
3. Open the manual pilot shutoff valve. If the pilot takeoff is downstream from the manual main fuel shutoff valve(s), slightly open the manual main valve to supply pilot gas flow. Make sure the main fuel is shut off just upstream from the burner inlet, or disconnect power from the automatic main fuel valve(s).
4. Close the master switch and start the system with a call for heat by raising the setpoint of the operating controller, see Fig. 15 or the relay module sequence. The sequence should start the ten-second INITIATE sequence.
5. Let the sequence advance through STANDBY and SAFE-START CHECK (PREPURGE in the RM7895). Ignition spark should occur and the pilot should light. If the pilot ignites, the FLAME LED will be lighted. Proceed to step 8.
6. If the pilot flame is not established in 15 or 30 seconds, safety shutdown occurs. Let the sequence complete its cycle. Consult the equipment operating manual for further information.
7. Push the reset pushbutton and let the system recycle once. If the pilot still does not ignite, make the following ignition/pilot adjustments.
 - a. Open the master switch and remove the relay module from the subbase.
 - b. On the subbase, jumper terminal 3 on the RM7890 (terminal 5 on the RM7895) to ignition terminal 8 or 10, refer to the appropriate wiring diagram (Fig. 4 through 7) to determine the proper terminal. Disconnect the leadwire to the pilot valve if it is connected to the same terminal.
 - c. Close the master switch to energize only the ignition transformer.
 - d. If the ignition spark is not strong and continuous, open the master switch and adjust the ignition electrode spark gap setting to the manufacturer recommendations.
 - e. Make sure the ignition electrodes are clean.
 - f. Close the master switch and observe the spark.
 - g. After a continuous spark is obtained, open the master switch and add a jumper on the subbase from terminal 3 (L1) (RM7890) or terminal 5 (L1) (RM7895) to the pilot terminal 8. Reconnect the leadwire from the pilot valve if it was disconnected in step b.
 - h. Close the master switch to energize both the ignition transformer and the pilot valve.
 - i. If the pilot does not ignite and if the ignition spark is still continuous, adjust the pressure regulator until a pilot is established.
 - j. When the pilot ignites properly and stays ignited, open the master switch and remove the subbase jumper(s) from terminals 3 to 8 or 3 to 10 (terminals 5 to 8 or 5 to 10 on the RM7895).
 - k. Check for adequate bleeding of the fuel line.
 - l. Reinstall the relay module on the subbase, close the master switch and return to step 4.
8. When the pilot ignites, measure the flame signal. If the pilot flame signal is unsteady or approaching the 1.25 Vdc minimum value, adjust the pilot flame size or detector position to provide a maximum and steady flame signal.

9. Recycle the system to recheck lightoff and pilot flame signal.
10. When the RUN period (MAIN IGN period for the RM7895) is displayed by the MAIN LED, make sure the automatic main fuel valve is open; then smoothly open the manual main fuel shutoff valve(s) and watch for main burner flame ignition. When the main burner flame is established, proceed to step 17.
11. If the main burner flame is not established within five seconds or the normal lightoff time specified by the equipment manufacturer, close the manual main fuel shutoff valve(s).
12. Recycle the system to recheck lightoff and pilot flame signal.
13. Let the relay module recycle to the RUN period (MAIN IGN period for the R7895). Smoothly open the manual fuel shutoff valve(s) and try lightoff again. (The first attempt may have been required to purge the lines and bring sufficient fuel to the burner.)
14. If the main burner flame is not established within five seconds or the normal lightoff time specified by the equipment manufacturer, close the manual fuel shutoff valve(s). Check all burner adjustments.
15. If the main burner flame is not established after two attempts:
 - a. Check for improper pilot size.
 - b. Check for excess combustion air.
 - c. Check for adequate fuel flow.
 - d. Check for proper gas supply pressure.
 - e. Check for proper valve operation.
 - f. Check for proper pilot flame positioning.
16. Repeat steps 11 through 15 to establish the main burner flame, then proceed to step 17.
17. With the sequence in RUN, make burner adjustments for flame stability and BTU input rating.
18. Shut down the system by opening the burner switch or by lowering the setpoint of the operating controller. Make sure the main flame goes out. There may be a delay due to gas trapped between the valve(s) and the burner. Make sure all automatic fuel valve(s) close.
19. Restart the system by closing the burner switch and/or raising the setpoint of the operating controller. Observe that the pilot is established during PILOT IGN and the main burner flame is established during RUN (MAIN IGN for RM7895) within the normal lightoff time.
20. Measure the flame signal. Continue to check for the proper signal, see Table 10, through the RUN period.
21. Run the burner through another sequence, observing the flame signal for:
 - a. Pilot flame alone (unless using direct spark ignition).
 - b. Pilot and main flame together. Also observe the time it takes to light the main flame. Ignition of the main flame should be smooth.
22. Return the system to normal operation.
23. Make sure all readings are in the required ranges before proceeding.

NOTE: Upon completing these tests, open the master switch and remove all test jumpers from the subbase terminals, limits/controls or switches.

Initial Lightoff Check for Direct Spark Ignition (DSI)

Use this check for gas and oil burners that do not use a pilot immediately following the preliminary inspection. Refer to the appropriate sample block diagram of field wiring for the ignition transformer and fuel valve(s) hookup.

NOTE: Low fuel pressure limits, if used, could be open; if so, bypass them with jumpers during this check.

1. Open the master switch.
2. Complete the normal checkout of the fuel supply and equipment as recommended by the equipment manufacturer.
3. Close all manual main fuel shutoff valve(s). Check that the automatic fuel valve(s) are closed. Make sure fuel is not entering the combustion chamber.
4. Close the master switch and start the system with a call for heat by raising the setpoint of the operating controller; see Fig. 15 or the relay module operating sequences. The primary sequence should start with the 10-second INITIATE sequence.
5. Let the sequence advance through STANDBY and SAFE-START CHECK for the RM7890 (PREPURGE for the RM7895) to Ignition Trial. Ignition spark should occur. Listen for the click of the first stage fuel solenoid valve(s).
6. Let the program sequence complete its cycle.
7. Open the manual fuel shutoff valve(s).
8. Push the reset button and recycle the program sequence through STANDBY and SAFE-START CHECK for the RM7890 (PREPURGE for the RM7895).
9. Watch for the FLAME LED to help determine when the first stage burner flame is established. If it is established, go to step 15.
10. If the first stage burner flame is not established within four seconds, or within the normal lightoff time specified by the equipment manufacturer, close the manual fuel shutoff valve(s) and open the master switch.
11. Check all burner adjustments.
12. Wait about three minutes. Close the master switch, open the manual fuel shutoff valve(s), and try again to light off the burner. The first attempt may have been required to purge the lines and bring sufficient fuel to the burner.
13. If the first stage burner flame is not established within four seconds or within the normal lightoff time specified by the equipment manufacturer, close the manual fuel shutoff valve(s) and open the master switch.
14. If necessary, repeat steps 8 through 13 to establish the first stage burner flame. Then proceed to step 15.
15. When the first stage burner flame is established, the sequence will advance to RUN. Make burner adjustments for flame stability and input rating. If a second stage is used, proceed to step 18.
16. Shut down the system by opening the burner switch or by lowering the setpoint of the operating controller. Make sure the burner flame goes out and make sure all automatic fuel valves close.
17. If used, remove the bypass jumpers from the low fuel pressure limit and subbase.
18. If a second stage is used, make sure the automatic second stage fuel valve(s) opened, and check the lightoff as follows (otherwise proceed to step 19):
 - a. Open the manual second stage fuel valve(s).
 - b. Restart the system by raising the setpoint of the operating controller.
 - c. When the first stage burner flame is established, watch for the automatic second stage fuel valve(s) top open. Observe that the second stage lights off properly.
 - d. Make burner adjustments for flame stability and input rating.
 - e. Shut down the system by lowering the setpoint of the operating controller. Make sure the burner flame goes out and that all automatic fuel valve(s) close.

19. Restart the system by closing the burner switch and/or raising the setpoint of the operating controller. Observe that the burner flame is established during PILOT IGN, within the normal lightoff time specified by the equipment manufacturer.
20. Measure the flame signal. Continue to check for the proper signal, see Table 10, through the RUN period. Any pulsating or unsteady readings will require further attention.
21. Make sure all readings are within the required ranges before proceeding.

NOTE: Upon completing these tests, open the master switch and remove all test jumpers from the subbase terminals, limits/controls or switches.

22. Return the system to normal operation.

Pilot Turndown Test (All Installations Using a Pilot)

Perform this check on all installations that use a pilot. The purpose of this test is to verify that the main burner can be lit by the smallest pilot flame that will hold in the flame amplifier and energize the FLAME LED. If using AMPLI-CHECK™ and one megohm per volt meter, the flame signal will fluctuate every time the amplifier does a self check.

NOTE: Low fuel pressure limits, if used, could be open. If so, bypass them with jumpers during this test.

1. Open the master switch.
2. Close the manual main fuel shutoff valve(s).
3. Connect a manometer (or pressure gauge) to measure pilot gas pressure during the turndown test.
4. Open the manual pilot shutoff valve(s).
5. Close the master switch and start the system with a call for heat by raising the setpoint of the operating controller. The primary sequence should start and PILOT IGNITION for the RM7890 (PREPURGE for the RM7895) should begin.
6. After the sequence has entered the normal burner run period, turn the pilot gas pressure down very slowly, reading the manometer (or gauge) as the pressure drops. Stop immediately when the FLAME LED goes out. Note the pressure at this point.

NOTE: If there is no flame present for the selected Flame Failure Response Test (FFRT), the relay module will lock out.

- a. If the Flame Failure Action jumper (see Table 6 or 7, JR2) is not clipped: allow the RM7890D to recycle to PILOT IGNITION or the RM7895E,F to recycle through PREPURGE. If the Flame Failure Action jumper is clipped: push the reset pushbutton and allow the RM7890D to recycle to PILOT IGNITION or the RM7895E,F to recycle through PREPURGE.
- b. As the control attempts to relight the pilot, increase the pilot pressure immediately until the FLAME LED comes on, and then turn it down slowly to obtain a pressure reading just above the dropout point or until the flame signal increases to approximately 1.25

Vdc. This step must be completed within 15 or 30 seconds, depending on the selected PFEP, or lock-out occurs.

- c. Turn the pilot back down slightly but not enough to cause the FLAME LED to go out. (Keep the pilot gas pressure just above the reading noted in step 6 above.)

NOTE: Step d requires two people, one to open the manual main fuel valve(s) and one to watch for ignition.

- d. With the sequence in the normal burner run mode, make sure the automatic fuel valve(s) is open. Smoothly open the manual main fuel shutoff valve(s) and watch for main burner lightoff.
- e. If the main flame is not established within five seconds or the normal lightoff period specified by the burner manufacturer, close the manual main fuel shutoff valve(s) and open the master switch. Then return to step 6a. If the burner flame is established in the normal lightoff period, proceed to step 10.
7. Recycle the burner and let the sequence advance to the PILOT IGN period for the RM7890D; advance to the PREPURGE period for the RM7895E,F.
8. Increase the pilot flame size by increasing its fuel flow until a smooth main flame is accomplished.
9. Reposition the flame rod until the pilot flame signal voltage is approximately 1.25 to 1.50 Vdc.
10. When the main burner lights reliably with the pilot at turndown, disconnect the manometer (or pressure gauge) and turn up the pilot gas flow to the level recommended by the equipment manufacturer.
11. If used, remove the bypass jumpers from the subbase terminals, limits/control or switches.
12. Run the system through another cycle to check for normal operation.
13. Return the system to normal operation.

Ignition Interference Test (All Flame Rods)

Test to be sure that a false signal from a spark ignition system is not superimposed on the flame signal.

Ignition interference can subtract from (decrease) or add to (increase) the flame signal. If it decreases the flame signal enough, it causes a safety shutdown. If it increases the flame signal, it can cause the FLAME LED to come on when the true flame signal is below the minimum acceptable value.

Start the burner and measure the flame signal with both ignition and pilot (or main burner) on, and then with only the pilot (or main burner) on. Any significant difference (greater than 0.5 Vdc) indicates ignition interference.

To Eliminate Ignition Interference

1. Make sure there is enough ground area.
2. Be sure the ignition electrode and the flame rod are on opposite sides of the ground area.
3. Check for correct spacing on the ignition electrode:
 - a. 6,000V systems 1/16 in. to 3/32 in. (1.6 mm to 2.4 mm).
 - b. 10,000V systems 1/8 in. (3.2 mm).
4. Make sure the leadwires from the flame rod and ignition electrode are not too close together.
5. Replace any deteriorated leadwires.

Flame Signal with Hot Combustion Chamber (All Installations)

1. After all initial start-up tests and burner adjustments are completed, operate the burner until the combustion chamber is at the maximum expected temperature.
2. Observe the equipment manufacturer warmup instructions.
3. Recycle the burner under these hot conditions and measure the flame signal.
4. Check the pilot alone for non-DSI (Direct Spark Ignition) applications or the main burner flame for DSI applications.
5. Check the FFRT of the flame amplifier.
6. Lower the setpoint of the operating controller and observe the time it takes for the burner flame to go out. This should be within 0.8 or 3 seconds maximum, depending on the amplifier selected.
7. If the flame signal is too low or unsteady, check the flame detector temperature.
8. Relocate the detector if the temperature is too high.
9. If the response time is still too slow, replace the Plug-in Flame Signal Amplifier.
10. If the detector is relocated or the amplifier is replaced, repeat all required Checkout tests.

Safety Shutdown Tests (All Installations)

Perform these tests at the end of Checkout, after all other tests are completed. If used, the external alarm should turn on.

1. Press the relay module reset pushbutton to restart the system.
2. Close the Airflow Interlock during STANDBY for 120 seconds (RM7895F).
3. Open the Airflow Interlock during PREPURGE, PILOT IGN, MAIN IGN or RUN period (RM7895).
 - a. Safety shutdown occurs if the Airflow ILK Switch Failure configuration jumper (JR3) is clipped (RM7895).
4. Detect flame 40 seconds after entry to STANDBY.
 - a. Simulate a flame to cause the flame signal voltage level to be at least 1.25 Vdc for 30 seconds after the initial 40 second entry into STANDBY (PREPURGE for RM7895).
 - b. Safety shutdown occurs.
5. Observe that pilot does not ignite.
 - a. Close the pilot and main fuel manual shutoff valve(s).
 - b. Depress the reset pushbutton.
 - c. Start the system.
 - d. Automatic pilot valve(s) should be energized but the pilot cannot ignite.
 - e. Safety shutdown will occur.
6. Observe loss of flame during RUN (if Flame Failure Action configuration jumper, JR2, is selected for Lockout, see Tables 6 and 7).
 - a. Open the main fuel manual shutoff valve(s) and open the manual pilot shutoff valve(s).
 - b. Depress the reset pushbutton.
 - c. Start the system. Startup should be normal and the main burner should light normally.
 - d. After the sequence is in the normal RUN period for at least ten seconds with the main burner firing, close the manual main and pilot fuel shutoff valve(s) to extinguish the main burner flame.
 - e. The flame signal drops below 1.25 Vdc within 0.8 or 3 seconds (depending upon the FFRT of the amplifier) after the main flame goes out.
 - f. Safety shutdown occurs.

IMPORTANT

1. If the relay module fails to shut down on any of these tests, take corrective action (refer to the Troubleshooting section or RM7890, RM7895 diagnostics) and return to the beginning of all checkout tests.
2. When all Checkout tests are completed, reset all switches to original states.

TROUBLESHOOTING

RM7890, RM7895 System Diagnostics

Troubleshooting control system equipment failures is easier with the relay module self-diagnostics and first-out annunciation through the optional KDM. In addition to an isolated spdt alarm relay (audible annunciation), the relay module provides visual annunciation by displaying the ALARM LED.

Self-diagnostics of the relay module enable it to detect and annunciate both external and internal system problems. External faults such as flame failures and false flame signals are annunciated by a lockout of the relay module that energizes the ALARM LED by using the optional KDM. Refer to the 7800 SERIES Relay Modules Checkout and Troubleshooting, form 65-0229 for additional information.

The relay module provides diagnostic information to aid the service mechanic to obtain information when troubleshooting the system. See Table 13.

The optional KDM displays sequence status messages indicating INITIATE, STANDBY, PREPURGE, PILOT IGN, MAIN IGN and RUN. The selectable messages also provide visual indication, current status and historical status of the equipment such as Flame Signal, Total Cycles, Total Hours, Fault History, Diagnostic Information and Expanded Annunciator Terminal Status (if used). With this information most problems can be diagnosed without extensive trial and error testing. Information available in the Diagnostic Information file includes: Device Type, Device Suffix, Software Revision, Manufacturing Code, Flame Amplifier Type, Flame Failure Response Time, Selectable Jumper Configuration Status and Terminal Status.

Diagnostic Information Index

The relay module with the optional KDM can monitor input/output terminals and can display the status of the terminal on the KDM display (for example, Pilot Valve T8 1<); see S7800 Keyboard Display Module specification, form 65-0090. A complete terminal description and terminal number are provided. The display shows the actual status of the terminal. If voltage is detected at the terminal, 1 is displayed; but if voltage is not present at the terminal, 0 is displayed.

Historical Information Index

The relay module has nonvolatile memory that allows it to retain historical information for the six most recent lockouts. Each of the six lockout files retains the cycle when the fault occurred, the hour of operation when the fault occurred, and the fault message and burner status when the fault occurred. The historical information can be viewed by the optional S7800 KDM.

SERVICE NOTE:

A lockout condition or restart of a relay module can be accomplished by pressing the reset pushbutton on the relay module or by pressing a remote reset pushbutton wired through an optional KDM, Data ControlBus™ Module, extension cable assembly, or remote reset module. A power-up reset module causes an electrical reset of the relay module but does not reset a lockout condition.

SERVICE NOTE:

Remove the access slot covers on the sides of the Q7800 Wiring Subbase to check voltages.



WARNING

Electrical Shock Hazard.
Can cause severe injury, death or property damage.
 Replace access slot covers on the Q7800B Wiring Subbase after performing voltage checks.

NOTE: Normal sequences are in **bold** type, while abnormal sequences are in regular type.

Table 13. Sequence and Status Hold Information.

Sequence	Information
INITIATE	The LED indicates the burner status, POWER, which is a stabilization period for the relay module to check for any fluctuations in ac line voltage inputs or control input on power-up or during normal operation. The timing of the INITIATE period is ten seconds before entering STANDBY .
If the relay is in a HOLD status, the following conditions can exist:	
INITIATE HOLD: (AC Frequency/Noise)	The LED indicates the burner status, POWER, and that the relay module is waiting for excess line noise to clear up. The burner sequence will not advance into STANDBY until the excess line noise, which prevents sufficient reading of the line voltage inputs, ceases or a line frequency error is detected.
INITIATE HOLD: (AC Line Dropout)	The LED indicates the burner status, POWER, and that ac line power has momentarily dropped out. The burner sequence will not advance into STANDBY until the ac line voltage has stabilized throughout the INITIATE sequence.
INITIATE HOLD: (AC Frequency)	The LED indicates the burner status, POWER, and that line frequency is faster than the expected value. The burner sequence will not advance into STANDBY until the line frequency returns to the proper value.
INITIATE HOLD: (Low Line Voltage)	The LED indicates the burner status, POWER, and that low line voltage has occurred. The burner sequence will not advance into STANDBY until the line voltage is at a sufficient level for proper operating parameters.
STANDBY	The LED indicates the burner status, POWER. The burner can be placed in STANDBY by opening the burner switch or if the operating controller indicates its setpoint has been satisfied. If a demand is present for burner operation, the burner sequence will not advance from STANDBY until the recycle limit closes.
If the relay module is in a HOLD status, the following conditions could exist:	
PURGE (RM7895 only)	The LED indicates the burner status, POWER, and that it is the period of time before ignition during which time the blower motor is running. The timing of the PURGE period is selectable.
PURGE HOLD: F/G (Flame Detected) (RM7895 Only)	The LED indicates the burner status, POWER and FLAME, and that a flame is detected. The burner sequence will not advance through PREPURGE because a flame is detected as being present. The sequence will hold waiting for the flame signal to clear. If the time exceeds 30 seconds, the relay module will lockout.
PURGE HOLD: T7 (Airflow Interlock) (RM7895 Only)	The LED indicates the burner status, POWER, and that the Airflow Interlock is not closed. The sequence will not advance into ignition until the Airflow Interlock proves closed. If this time exceeds a 30-second HOLD , the relay module will lockout.
STANDBY HOLD: F/G (Flame Detected)	The LED indicates the burner status, POWER and FLAME, and that a flame is detected. A demand is present for burner operation. The burner sequence will not advance to SAFE START CHECK (PREPURGE in the RM7895) because a flame is detected as being present. The sequence will not advance to SAFE START CHECK until the flame signal clears. If the flame signal does not clear within 40 seconds, the relay module will lockout.
SAFE START CHECK (RM7890 Only)	The LED indicates the burner status, POWER, which is the period of time after STANDBY . The RM7890 is verifying that a flame is not present before the start of Ignition Trials. If a flame is present, the RM7890 will recycle to STANDBY .

Table 13. Sequence and Status Hold Information. (Continued)

Sequence	Information
PILOT IGN	The LED indicates the burner status, POWER, PILOT, and FLAME, which is the period of time the relay module permits the pilot valve and ignition to be energized and the pilot flame to be established.
MAIN IGN (RM7895 Only)	The LED indicates the burner status, POWER, PILOT, FLAME, and MAIN, which is the period of time the RM7895 permits the main valve to be open and the main flame to be tested.
RUN	The LED indicates the burner status, POWER, PILOT, FLAME and MAIN, which is the period of time after the Ignition Trials and before the operating controller setpoint is reached. During this time, the burner is firing under the control of the operating controller.
RESET/ALARM TEST	The LED indicates the burner status, POWER and ALARM. This condition indicates that the reset pushbutton is pressed. If it is held for more than four seconds, the alarm output is energized. The alarm output will be de-energized after the reset pushbutton is released.

Automation and Control Solutions

Honeywell International Inc.
1985 Douglas Drive North
Golden Valley, MN 55422
customer.honeywell.com

Honeywell Limited-Honeywell Limitée
35 Dynamic Drive
Toronto, Ontario M1V 4Z9

® U.S. Registered Trademark
© 2006 Honeywell International Inc.
65-0179—3 M.S. Rev. 07-06



Printed in U.S.A. on recycled
paper containing at least 10%
post-consumer paper fibers.

Honeywell