

201391, 32003167-001 Shaft Adapters for ML7999 ControLinks™ Actuator

INSTALLATION INSTRUCTIONS

APPLICATION

This document provides installation instructions for using the 201391 Shaft Adapter (for 3/8 in. round or square valve shafts) and the 32003167-001 Shaft Adapter (for 5/16 in. round or square valve shafts) to correctly mount the ML7999 ControLinks™ Actuator.

SPECIFICATIONS

Models:

32003167-001 5/16 in. shaft adapter for round or square valve shafts.

201391 3/8 in. shaft adapter for round or square valve shafts.

Dimensions: See Fig. 1.

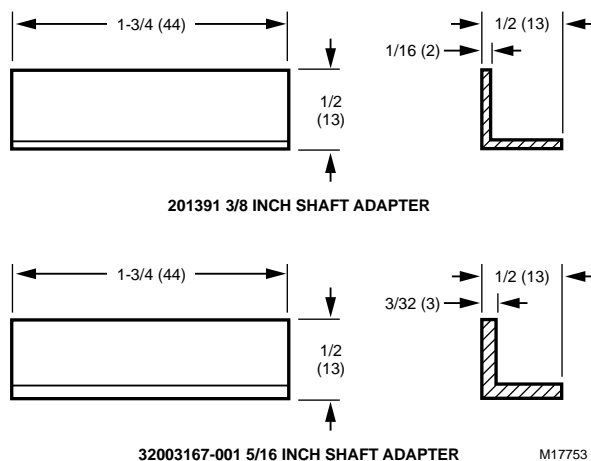

Fig. 1. 201391 and 32003167-001 ML7999 Shaft Adapters measurements in in. (mm).

INSTALLATION

⚠ WARNING

**Fire or Explosion Hazard.
Can cause serious injury or death.**

Turn off gas supply upstream from the valve to prevent fire, explosion or asphyxiation hazard.

IMPORTANT

An ML7999 ControLinks™ Actuator mounting kit may be required for the valve being installed. Check the specifications supplied with the valve.

Mounting instructions for the two different sizes of shaft adapters are identical. Please follow the instructions carefully. See Fig. 1.

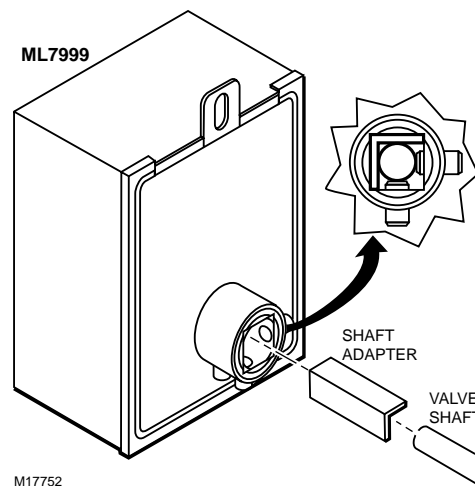

Fig. 2. Connecting the ML7999 Actuator to the valve using the shaft adapter.

1. Place the actuator over the valve shaft.
2. Insert the shaft adapter into the actuator hub with the adapter on the opposite side of the hub setscrews (see inset in Fig. 2).



3. Rotate the valve shaft to match the actuator position.
4. Partially tighten the hub setscrews to ensure the actuator seats firmly against the mounting bracket with the valve shaft centered in the actuator hub.
5. Tighten the anti-rotation bolt to the torque recommended for the selected bolt/nut combination.
6. Tighten the setscrews against the shaft to a torque of 60 lb.-in.
7. Wire the actuator according to the instructions provided.
8. Check the actuator operation by applying power and running the actuator through at least one complete cycle.
9. If the operation is correct, turn on the gas supply to the system.

Honeywell

Home and Building Control

Honeywell
1985 Douglas Drive North
Golden Valley, MN 55422

Home and Building Control

Honeywell Limited-Honeywell Limitée
35 Dynamic Drive
Scarborough, Ontario
M1V 4Z9

