

MILLTRONICS

MILLFLO DRY SOLIDS FLOWMETER

Instruction Manual

March 2001



MILLFLO FLOWMETER

Safety Guidelines

Warning notices must be observed to ensure personal safety as well as that of others, and to protect the product and the connected equipment. These warning notices are accompanied by a clarification of the level of caution to be observed.

Qualified Personnel

This device/system may only be set up and operated in conjunction with this manual. Qualified personnel are only authorized to install and operate this equipment in accordance with established safety practices and standards.

Warning: This product can only function properly and safely if it is correctly transported, stored, installed, set up, operated, and maintained.

Note: Always use product in accordance with specifications.

Copyright Siemens Milltronics Process Instruments Inc. 2000. All Rights Reserved	Disclaimer of Liability
This document is available in bound version and in electronic version. We encourage users to purchase authorized bound manuals, or to view electronic versions as designed and authored by Siemens Milltronics Process Instruments Inc. Siemens Milltronics Process Instruments Inc. will not be responsible for the contents of partial or whole reproductions of either bound or electronic versions.	While we have verified the contents of this manual for agreement with the instrumentation described, variations remain possible. Thus we cannot guarantee full agreement. The contents of this manual are regularly reviewed and corrections are included in subsequent editions. We welcome all suggestions for improvement. Technical data subject to change.

MILLTRONICS® is a registered trademark of Siemens Milltronics Process Instruments Inc.

Contact SMPI Technical Publications at the following address:

Technical Publications
Siemens Milltronics Process Instruments Inc.
1954 Technology Drive, P.O. Box 4225
Peterborough, Ontario, Canada, K9J 7B1
Email: techpubs@milltronics.com

For the library of SMPI instruction manuals, visit our Web site: www.milltronics.com

ABOUT THIS MANUAL

This manual, PL-304, covers the installation and operation of the Millflo dry solids flowmeter.

First and foremost, it is essential that this manual and the other associated manuals be read and understood before installation and start-up of any component of the weighing system to which the Millflo is being applied. Failure to do so may cause serious equipment damage or personnel injury. Adhering to the installation and operating procedures will insure a quick trouble free installation and allow for maximum accuracy and reliability of your weighing system.

ABOUT THE MILLFLO

The Millflo is a flowmeter used to measure the rate of flow of dry bulk solids under gravity feed conditions. It incorporates a flowguide to condition the inflow of material, a sensing plate supported by a load cell to sense the flow, and a discharge to direct the flow back into the process. The load cell provides an electronic signal, proportional to material flow rate, which is fed to the Milltronics integrator. Thus, flow measurement is accomplished without disturbing the process and without degrading the process material.

The Millflo features easy installation into standard pipe sizes, simple operation, and fast and accurate flow response.

It is important to understand that the Millflo is an accurate and repeatable force sensor. Its performance is ultimately dependent upon the consistency of the flow of material into the flowmeter and the quality of the installation.

SPECIFICATIONS

MILLFLO

Flow Rate - 1 TPH to 250 TPH dependent upon range (see chart below) and product bulk density

Product - fine powder to 13 mm (1/2 inch) (see chart below)

Operating Temperature - -40 to 65 °C (-40 to 150 °F)

Non-Repeatability - ± 0.2%

Accuracy - ± 1% of full scale

Fabrication

- assembly: - all welded housing and flowguide
- material: - mild steel, painted
- optional: 304 or 316 stainless steel
- gasketing: - silicone rubber
- sensing plate: - 304 stainless steel
- optional: - 316 stainless steel
- wear resistant coatings

Load Cell

- stainless steel
- temperature: - -40 to 85 °C (-40 to 185 °F) maximum range
- 0 to 65 °C (32 to 150 °F) internally compensated
- output: - 2 mV / V excitation at rated load cell capacity

Approvals - CE compliant

Weight - see chart below

Flowmeter Range - the following ranges and load cell sizes have been specified

Size (inlet)	Min. Flow	Max. Flow	Particle Size	Load Cell Size	Weight
4"	0 - 1 STPH 0 - 1 t/h	0 - 15 STPH 0 - 14 t/h	6 mm (1/4")	2 or 5 lb	20 kg (45 lb)
6"	0 - 4,3 STPH 0 - 4 t/h	0 - 38 STPH 0 - 35 t/h	10 mm (3/8")	5 or 10 lb	32 kg (70 lb)
8"	0 - 20 STPH 0 - 18 t/h	0 - 87 STPH 0 - 80 t/h	10 mm (3/8")	10 or 20 lb	90 kg (200 lb)
10"	0 - 50 STPH 0 - 45 t/h	0 - 147 STPH 0 - 13 t/h	13 mm (1/2")	50 lb	113 kg (250 lb)
12"	0 - 100 STPH 0 - 90 t/h	0 - 250 STPH 0 - 230 t/h	13 mm (1/2")	100 lb	136 kg (300 lb)

Maximum flowrates are based on material densities of 1.6 t /m³ (100 lb/ft³).

OPERATION

The Millflo is designed to react to the horizontal component of force being applied to the sensing assembly. The Millflo consists of two physical components:

- the housing which includes the flowguide and the outlet. Its purpose is to support the sensing assembly and to guide the flow of material.
- the sensing assembly, composed of the sensing plate and the load cell.

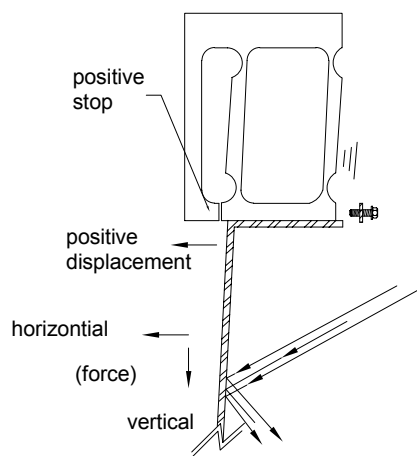
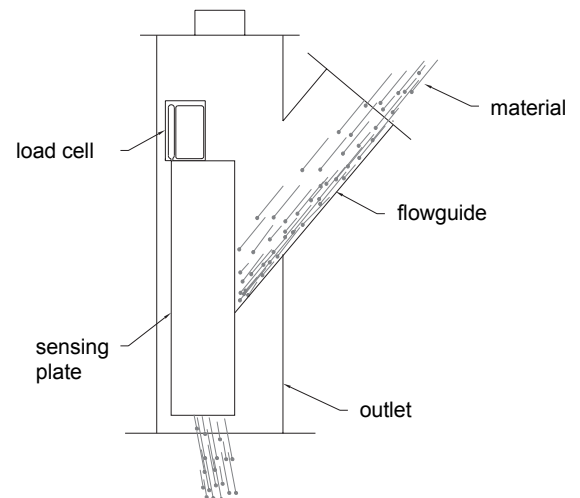

The material travels down the flowguide, impacts upon the sensing plate and is discharged via the outlet. The force exerted on the sensing plate has both a vertical and horizontal component. The design of the load cell is such that it reacts to the horizontal component only; the vertical component is ignored. The sensing plate is displaced proportionally to the material flow and is not susceptible to material build up, so long as it does not bridge across to the housing. Positive displacement of the load cell is limited by the positive stop incorporated in the design of the load cell.

The displacement of the load cell is sensed by its strain gauges. These convert the excitation signal from the electronic integrator to produce a signal proportional to material flow.

The load cell must be protected against excessive negative displacement which could functionally destroy it. The negative stop is factory set so that the output signal is limited to -20 mV when the load cell is forced to open in the negative direction.

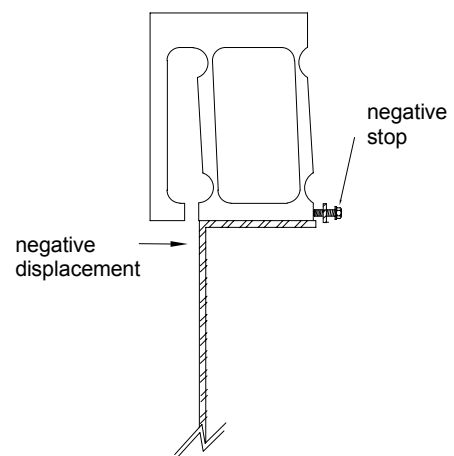
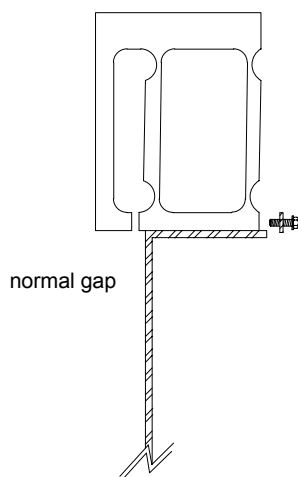

Under no flow conditions, the load cell/sensing plate assembly will be at rest or static zero. Under this condition the negative stop should not contact the load cell and the output signal from the load cell will be approximately -5 to 0 mV DC.

INSTALLATION

PREAMBLE

Prepare the site in accordance with the Milltronics drawing(s) provided. If no job drawings were provided or if there is confusion or doubt as to the Millflo's installation, please consult your Milltronics representative.

When unpacking the Millflo, care should be taken to avoid subjecting the unit to mechanical shock. Excessive mechanical shock can cause damage to the housing or load cell/sensing plate assembly, incurring costly repairs and installation or production delays. The Millflo is generally shipped assembled with the sensing plate arrested to prevent damage to the load cell.

The Millflo should be visually inspected for shipping damage. If damage is suspected, contact your Milltronics representative and the shipping carrier.

When handling the Millflo, ensure the shipping stop is in place to secure the sensing plate. Never subject the Millflo to shock by blows when trying to position it.

WELDING

Extreme caution should be used when arc welding in the area of the flowmeter. Insure that no welding current will flow through the flowmeter. Welding currents through the flowmeter are sufficient to functionally destroy the load cell. During welding, removal of the sensing plate is recommended.

LOAD CELL HANDLING

The load cell can tolerate very little negative displacement, otherwise the load cell may be functionally destroyed. When handling the load cell, care must be taken not to force the gap open.

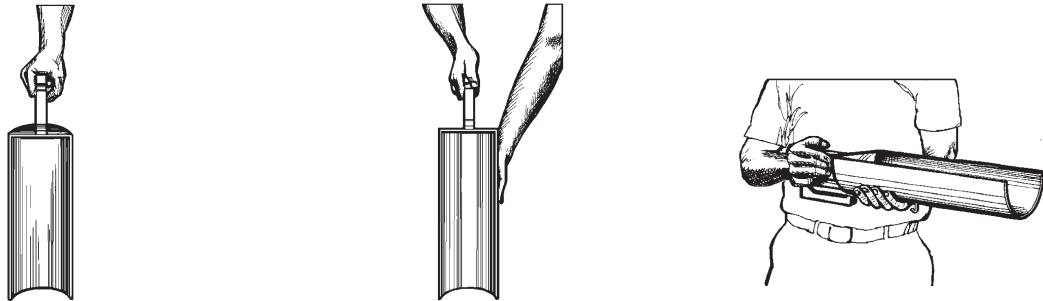

SUPPORT LOAD CELL THROUGHOUT HANDLING IN NON-VERTICAL POSITIONS.

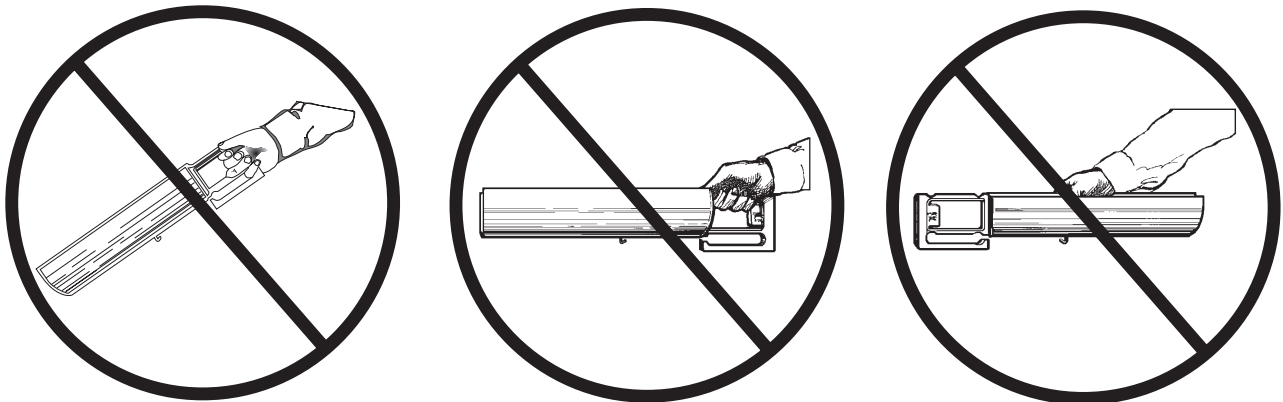

IMPROPER HANDLING MAY FUNCTIONALLY DESTROY LOAD CELL

DISASSEMBLY

It is advisable to remove the load cell/sensing plate assembly from the housing prior to installation.

1. - remove the access cover
- loosen the shipping rod nuts as shown and remove . Retain calibration weight cable for use in the calibration procedure.
- secure access door.
2. - remove and hold top cover/junction box assembly. Avoid applying stress to the load cell cable which is connected through the cover to the junction box.
3. - grasp the load cell by the upper cross member. Refer to the diagrams in the Load Cell Handling section.
4. - remove load cell mounting screws (2 places).
5. - lift load cell/sensing plate assembly up and out of the housing, keeping the sensing assembly vertical.
6. - set the assemblies aside in a safe place. While transporting, support the load cell / sensing plate assembly as shown in the diagrams in the Load Cell Handling section.

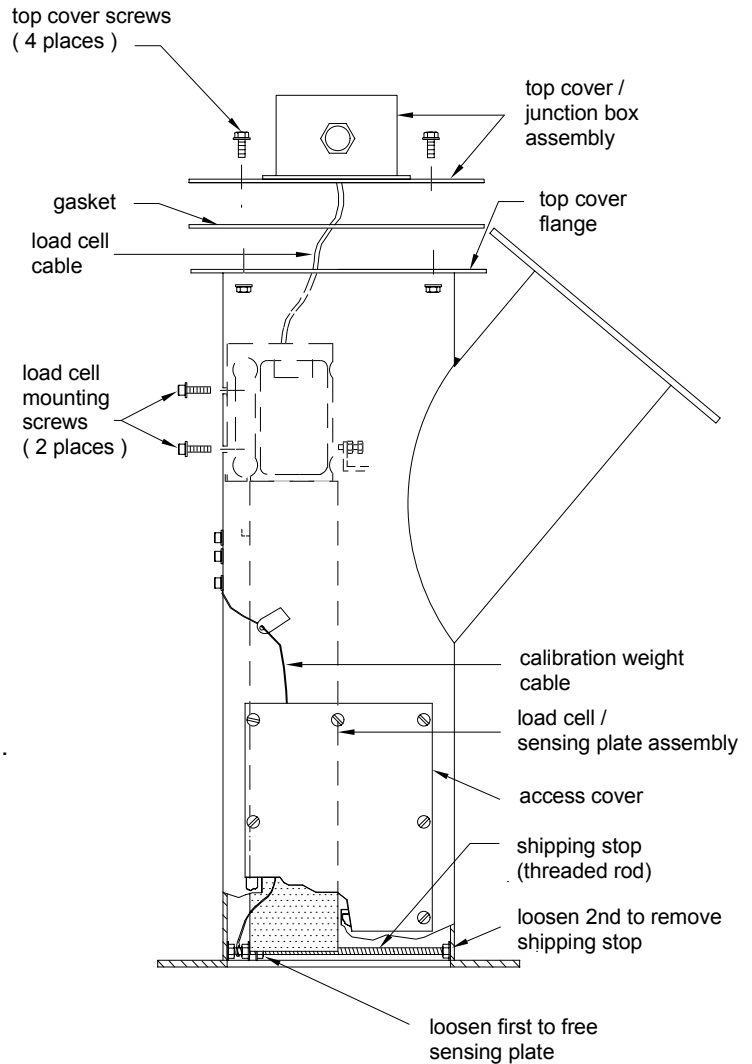

INSTALLATION OF SHIPPING STOP

Whenever the unit is to be moved the shipping stop should be reinstalled to prevent damage to the load cell/sensing plate assembly.

- with the sensing plate resting in its static position insert threaded rod as shown.
- tighten the two end nuts against the housing to secure the rod in place.
- turn the two opposing sensing plate locking nuts toward the sensing plate, maintaining the sensing plate in its static position. Tighten nuts to secure sensing plate.

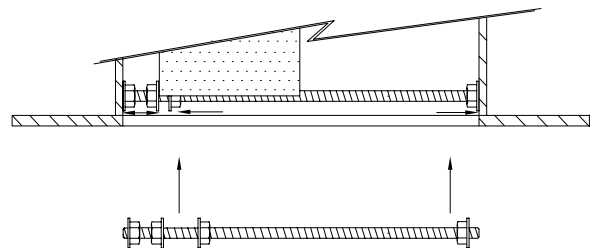

INSTALLATION

1. - set the Millflo housing in place ensuring that the flowguide and outlet gaskets are correctly located.
2. - the housing must be vertical within $\pm 1^\circ$ in two planes 90° apart.
3. - bolt the flowguide and outlet flanges to the process piping.
4. - if the load cell/sensing plate assembly was not removed prior to beginning the installation procedure, the shipping stop must be removed. Refer to Disassembly to remove the shipping stop.

- if the load cell/sensing plate assembly was removed, reverse the disassembly procedure to reassemble the load cell/sensing assembly into the housing and to replace the cover/junction box assembly on to the top access flange. Do not reinstall the shipping stop. Exercise caution while handling the load cell/sensing plate assembly. Refer to the diagrams in the Load Cell Handling section.
5. - wire the unit in accordance with Milltronics supplied connection diagrams or as described in the integrator instruction manual.

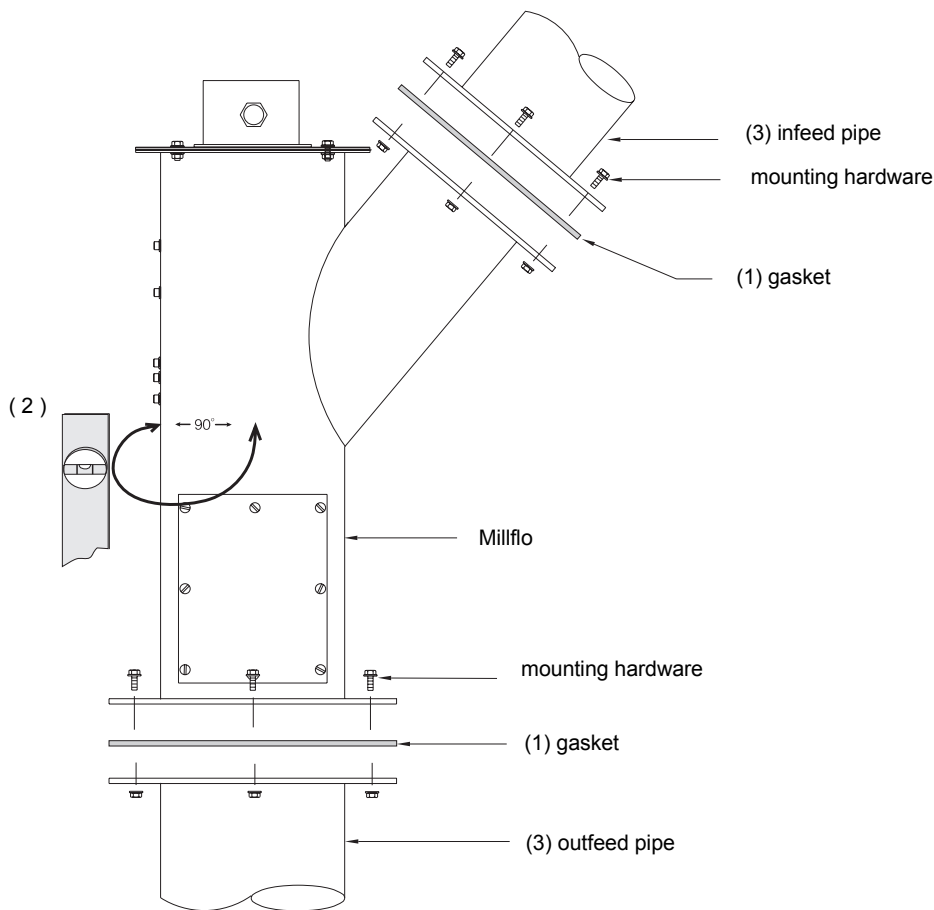

all items other than Millflo supplied by customer

CALIBRATION

GENERAL

After the Millflo has been properly installed, calibration of the solids flowmeter system should be done in conjunction with the integrator. Refer to the integrator instruction manual for programming and calibration. The calibration is initially done using a test weight. Material tests are recommended to achieve maximum accuracy.

TEST RATE

The test rate is the material flowrate represented by the test weight. The test weight is used to simulate the horizontal forces of the material hitting the sensing plate.

CALCULATION OF TEST WEIGHT AND TEST RATE

The test weight should be selected to represent a calibration point of 60% to 80% of the Design flowrate based on the Millflo Calibration Constant of 45 g / TPH (tons per hour) ^{*}.

Test Weight = Design Flowrate x Calibration Point x Calibration Constant

Test Rate = $\frac{\text{Test Weight}}{\text{Calibration Constant}}$

For Example:

If the Design Flowrate is 6 TPH, then

Test Weight 60 % = 6 TPH x 60% x 45 g/TPH
= 162 g

Test Weight 80% = 6 TPH x 80% x 45 g/TPH
= 216 g

∴ the test weight should be between 162 g and 216 g.

If an available test weight of 200 g is used, then

Test Rate = $\frac{200\text{g}}{45 \text{ g TPH}}$
= 4.444 TPH

* The Calibration Constant is based upon experience acquired by Milltronics. It represents an average of a range of values covering various material flow arrangements and materials handled by the Millflo. It is thus only an approximate value to be used in the calculation of the Test Rate. Through the running of material tests, the Test Rate may be factored to obtain its optimum value which should lie in the range of 50% to 100% of the Design Rate. The Test Rate should never exceed 100% of the Design Rate.

ZERO

Perform the zero calibration as described in the Calibration section of the integrator instruction manual.

SPAN

- Install the calibration pulley and bracket assembly to the flowmeter housing.
- Hang the test weight over the calibration pulley using the test weight cable.
- Perform the span calibration as described in the calibration section of the integrator instruction manual.
- After the span calibration has been completed, remove the test weight and pulley assembly and store them .

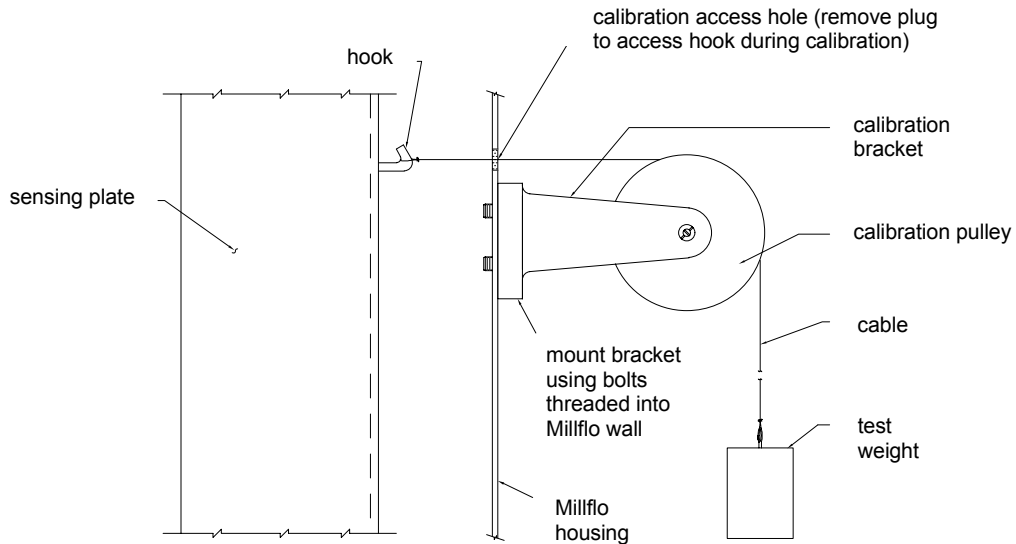

MATERIAL TEST

Calibration of the flowmeter by test weight is not a dynamic simulation and yields but an approximate span calibration. Effective material flowability, friction and velocity can only be reproduced by running actual material tests.

At least two 5 minute samples should be taken to ensure repeatability.

Refer to " Material Test " and subsequent " Factoring " of the flowmeter sections of the integrator manual.

RE-RATING

After material tests have been done and a decision is made to re-rate the Millflo at a higher or lower capacity, (with $\pm 20\%$ of the design rate specified at the time of purchase) only the design rate parameter of the integrator needs to be changed. Following that, a recalibration of the zero and span can be performed using the old test weight and test rate. New material tests will not be required.

MAINTENANCE

PERIODIC RECALIBRATION

If the flowmeter is properly installed, the zero and span calibrations will require limited attention. However, to maintain the accuracy of your flowmeter's operation, the zero and span should be periodically redone. The frequency of recalibration is highly dependent upon the application in which the flowmeter is being used and the severity of its operating conditions. It is suggested that frequent recalibrations be performed at first (noting the deviations), then tapering off in frequency as time and experience dictate.

Refer to the Programming and Calibration sections of the integrator manual.

CHECKS

If material sticks to the sensing plate, incorporate a program to ensure that the impingement area remains clean. If sticking of the material persists, contact your Milltronics representative.

Check for material bridging across the load cell or sensing plate to the housing which can restrict the free movement of either component.

Do not strike the flowmeter, its components or adjacent piping to dislodge material.

Check for wearing of the sensing plate. If wear is excessive contact your Milltronics representative.

SPARE PARTS

The following are the recommended spare parts. As each may be available in more than one option, consult Milltronics for assistance in ordering spare parts. In all correspondence please quote the Milltronics Serial Number of the unit for which the parts are required.

- load cell
- sensing plate

MILLFLO OUTLINE AND DIMENSIONS

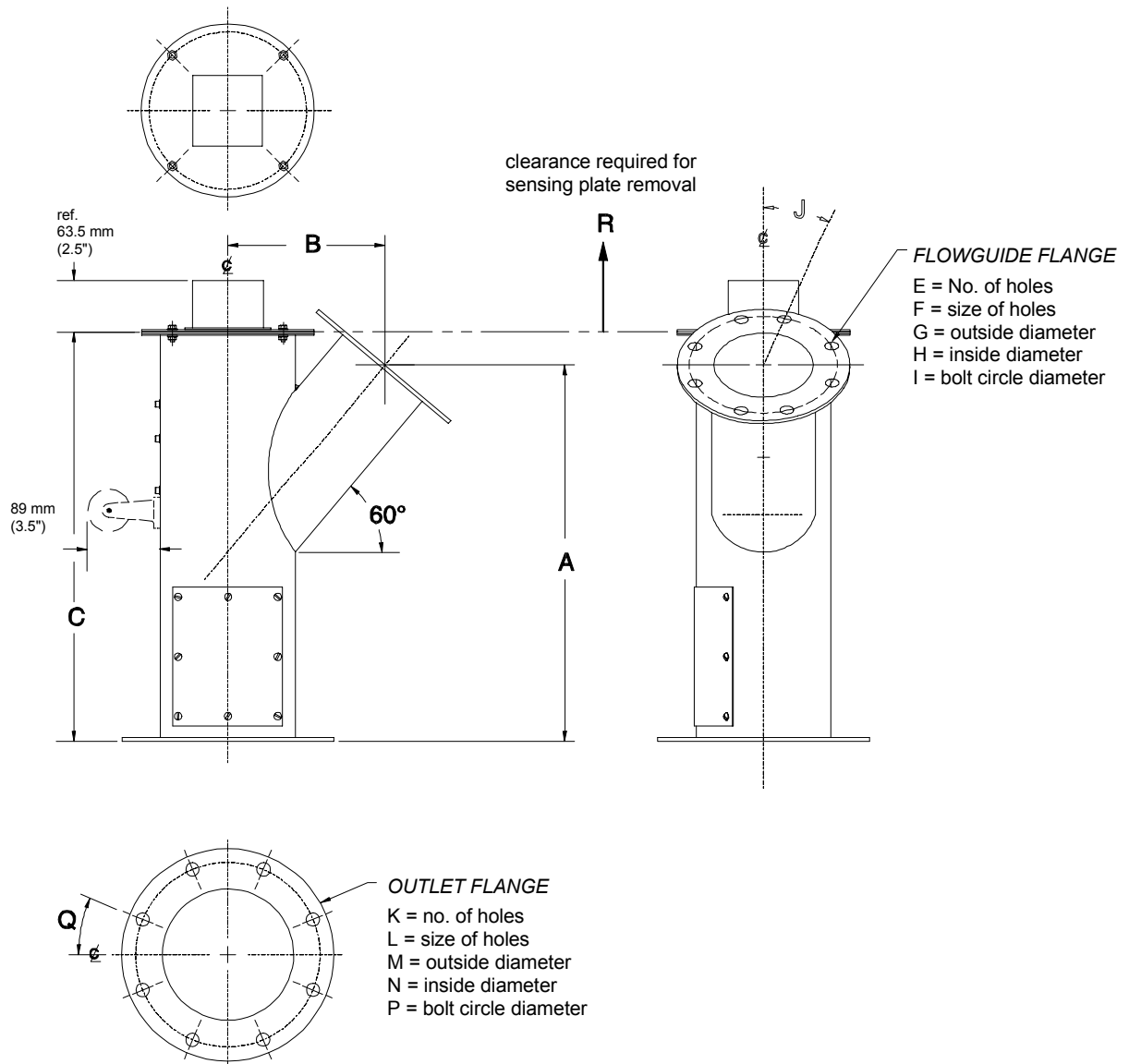

NOTE: All dimensions are in millimeters.
() denotes dimensions in inches

Flowguide and outlet: DIN versions are available.
Flanges match ANSI patterns.

Size	Millflo Dimensions				ANSI		DIN	
	A	B	C	D	E	F	E	F
100 mm (4")	597 mm (23.5")	203 mm (8")	660 mm (26")	413 mm (16")	108 mm (4.26")	162 mm (6.36")	105 mm (4")	155 mm (6")
150 mm (6")	838 mm (33")	254 mm (10")	914 mm (36")	660 mm (26")	162 mm (6.38")	212 mm (8.33")	155 mm (6")	206 mm (8")
200 mm (8")	1168 mm (46")	356 mm (14")	1244 mm (49")	711 mm (28")	212 mm (8.3")	315 mm (12.39")	206 mm (8")	305 mm (12")
250 mm (10")	1321 mm (52")	406 mm (16")	1397 mm (55")	813 mm (32")	265 mm (10.42")	343 mm (13.5")	260 mm (10")	336 mm (13.2")
300 mm (12")	1575 mm (62")	483 mm (19")	1651 mm (65")	914 mm (36")	315 mm (12.39")	394 mm (15.5")	305 mm (12")	387 mm (15.2")

MILLFLO WIRING

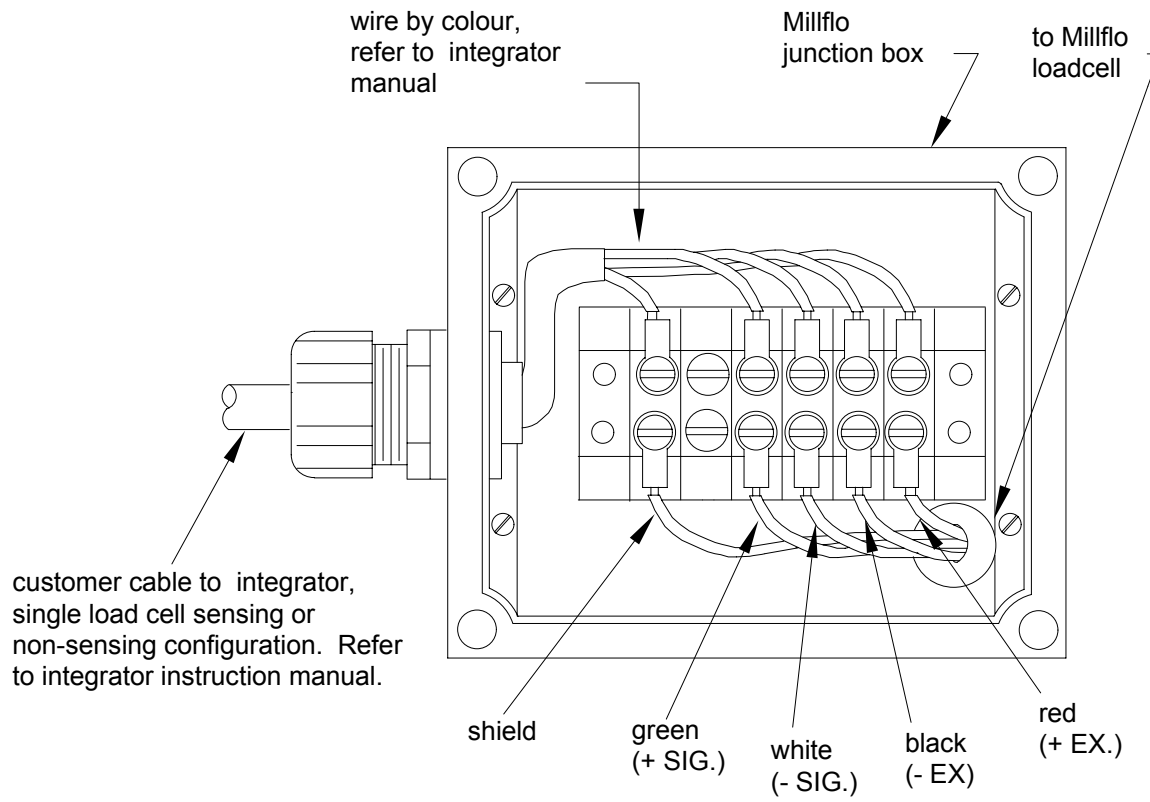

www.milltronics.com

MILLTRONICS

Siemens Milltronics Process Instruments Inc.
1954 Technology Drive, P.O. Box 4225
Peterborough, ON, Canada K9J 7B1
Tel: (705) 745-2431 Fax: (705) 741-0466
www.milltronics.com

© Siemens Milltronics Process Instruments Inc. 2001
Subject to change without prior notice



Printed in Canada