

Milltronics Universal Belt Scale (MUS) operates with such products as aggregates, sand or minerals, providing continuous in-line weighing at a minimal cost. With no cross bridge, this versatile unit will fit most conveyor widths and standard idlers, and product build-up is reduced.

The modular construction and easy assembly of the MUS ensure quick delivery to meet even the tightest of schedules. Where scales are moved from conveyor to conveyor, the MUS also provides unmatched flexibility.

Operating with one of Milltronics' microprocessor-based integrators, the MUS provides indication of flow rate, total weight, belt load and speed of bulk solids materials on a belt conveyor. A Milltronics speed sensor monitors conveyor belt speed for input to the integrator.



Product Features

- Unique modular design
- Simple installation
- Low cost
- Easy retrofit

Technical Specifications

Accuracy

- ± 0.5 to 1% of totalization over 3 to 1 operating range, application dependent

Belt Width

- standard duty up to 1000 mm (CEMA width up to 42")
- heavy duty 1200 mm and up (CEMA width 48" and up) although can be applied to narrower conveyors
- refer to the outline dimension section

Belt Speed

- up to 3 m/s (600 fpm)

Capacity

- up to 5000 TPH at maximum belt speed

Conveyor Incline

- $\pm 20^\circ$ from horizontal, fixed incline
- up to $\pm 30^\circ$ with reduced accuracy

Idler Profile

- flat to 35°
- up to 45° with reduced accuracy

Idler Diameter

- 50 to 180 mm (2 to 7")

Idler Spacing

- 0.6 to 1.5 m (2.0 to 5.0 ft)

Load Cell

- construction: aluminum
 - excitation: 10 Vdc nominal, 15 Vdc maximum
 - output: 2 mV/V excitation at rated load cell capacity
 - non-linearity: 0.02% of rated output
 - hysteresis: 0.02% of rated output
 - non-repeatability: 0.01% of rated output
 - capacity:
 - standard duty ranges: 20, 30, 50, 75, 100 kg
 - heavy duty ranges: 50, 100, 150, 200, 500 kg
 - overload: safe 150% of rated capacity, ultimate 300% of rated capacity
 - temperature:
 - 40 to 65°C (-40 to 150°F) operating range
 - 10 to 40°C (15 to 105°F) compensated
- Dimensions vary for standard and heavy duty versions

Hazardous Locations

- with the use of approved intrinsically safe barrier strips

Weight

- standard duty up to 44 lbs. (22 lbs./side), 20 kg (10 kg/side)
- heavy duty up to 64 lbs. (32 lbs./side), 30 kg (15 kg/side)

Interconnecting Wiring (to integrator)

- < 150 m (500 ft.) 18 AWG 6 conductor shielded cable
- > 150 m (500 ft.) to 300m (1000 ft.) 18 to 22 AWG 8 conductor shielded cable

Approvals

- CE compliant

MUS Belt Scale

Dimensions

Standard Duty

side view

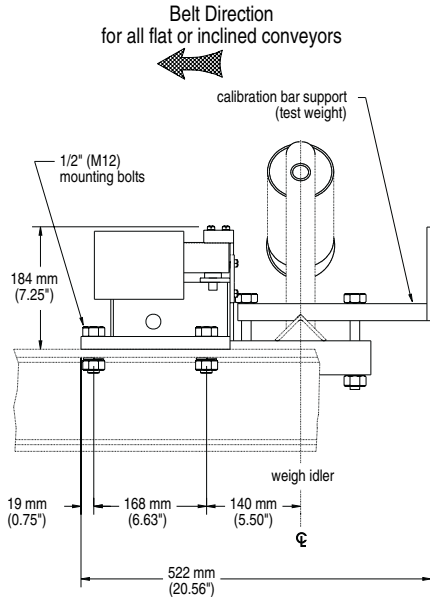

Notes:

(2) approach and 2 retreat idlers should be aligned with the weigh idler to within 0.8 mm (+1/32") to 0 mm (0").

front view

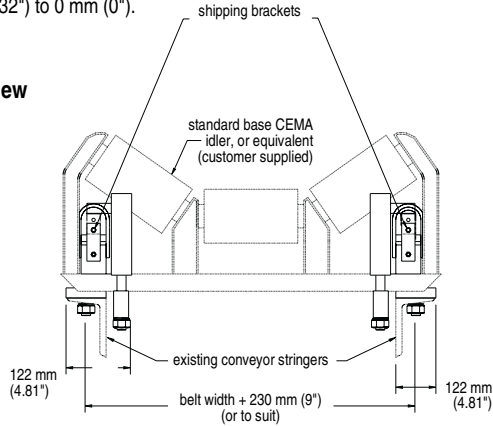

Heavy Duty

side view

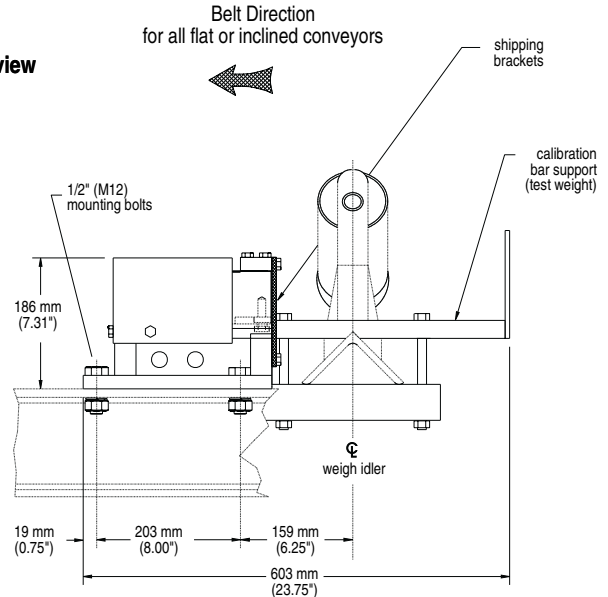

Notes:

(2) approach and 2 retreat idlers should be aligned with the weigh idler to within 0.8 mm (+1/32") to 0 mm (0").

front view

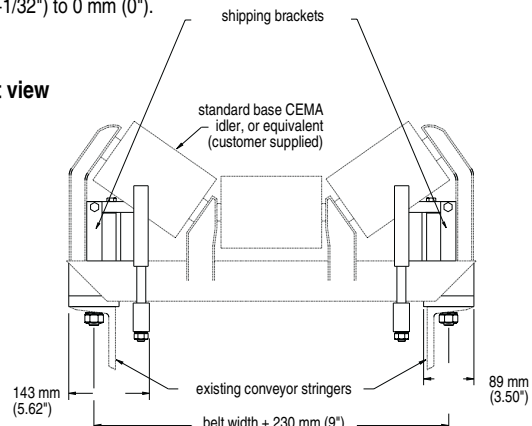

Wiring

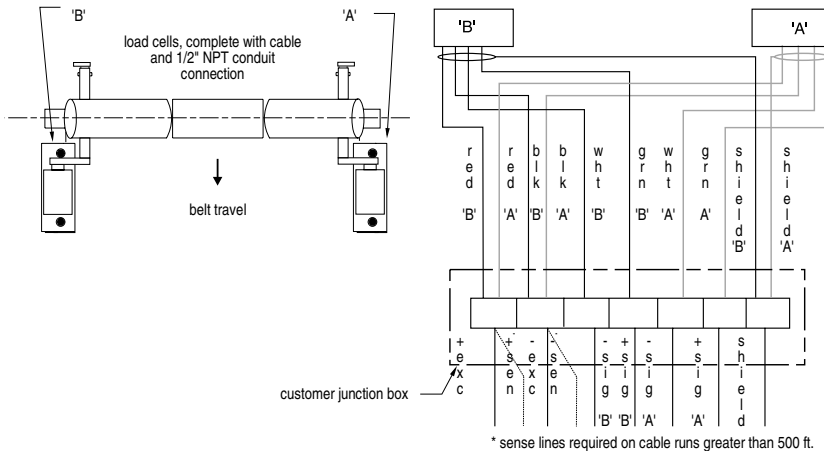

* sense lines required on cable runs greater than 500 ft.



Australia	Tel.: +61 3-9695-2400	Fax: +61 3-9695-2450
Belgium	Tel.: +32(0)3326 45 54	Fax: +32(0)3326 05 25
Canada	Tel.: +1 705-745-2431	Fax: +1 705-741-0466
France	Tel.: +33 4 42 65 69 00	Fax: +33 4 42 58 63 95
Germany	Tel.: +49 721 595 4607	Fax: +49 721 595 4937
Hong Kong	Tel.: +85 2-2856-3166	Fax: +85 2-2856-2962
Mexico	Tel.: +52 5 575-27-28	Fax: +52 5 575-26-86
The Netherlands	Tel.: +31(0)76 542 7 542	Fax: +31(0)76 542 8 542
Switzerland	Tel.: +41 21 791 58 28	Fax: +41 21 791 58 40
United Kingdom	Tel.: +44 1905-450500	Fax: +44 1905-450501
United States	Tel.: +1 817-277-3543	Fax: +1 817-277-3894

www.milltronics.com