

**MSI  
SINGLE IDLER BELT SCALE**

Instruction Manual PL-319

January 2001

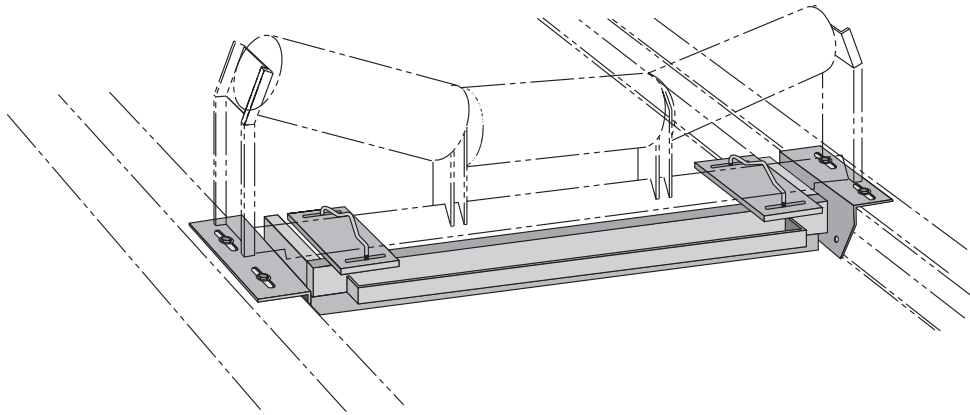

MSI BELT SCALE

## Safety Guidelines

Warning notices must be observed to ensure personal safety as well as that of others, and to protect the product and the connected equipment. These warning notices are accompanied by a clarification of the level of caution to be observed.

## Qualified Personnel

This device/system may only be set up and operated in conjunction with this manual. Qualified personnel are only authorized to install and operate this equipment in accordance with established safety practices and standards.

**Warning:** This product can only function properly and safely if it is correctly transported, stored, installed, set up, operated, and maintained.

**Note:** Always use product in accordance with specifications.

Copyright Siemens Milltronics Process Instruments Inc. 2000. All Rights Reserved	Disclaimer of Liability
<p>This document is available in bound version and in electronic version. We encourage users to purchase authorized bound manuals, or to view electronic versions as designed and authored by Siemens Milltronics Process Instruments Inc. Siemens Milltronics Process Instruments Inc. will not be responsible for the contents of partial or whole reproductions of either bound or electronic versions.</p>	<p>While we have verified the contents of this manual for agreement with the instrumentation described, variations remain possible. Thus we cannot guarantee full agreement. The contents of this manual are regularly reviewed and corrections are included in subsequent editions. We welcome all suggestions for improvement.</p> <p>Technical data subject to change.</p>

MILLTRONICS® is a registered trademark of Siemens Milltronics Process Instruments Inc.

Contact SMPI Technical Publications at the following address:

Technical Publications  
Siemens Milltronics Process Instruments Inc.  
1954 Technology Drive, P.O. Box 4225  
Peterborough, Ontario, Canada, K9J 7B1  
Email: [techpubs@milltronics.com](mailto:techpubs@milltronics.com)

For the library of SMPI instruction manuals, visit our Web site: [www.milltronics.com](http://www.milltronics.com)

# TABLE OF CONTENTS

---

---

Title	Page
ABOUT THIS MANUAL	5
ABOUT THE MSI	5
SPECIFICATIONS	6
OPERATION	7
INSTALLATION	
Introduction	8
Welding	8
Load Cell Handling	8
Installation Procedure	9
CALIBRATION	
General	13
Test Load	13
Zero	13
Span	13
Material Test	14
Re-Rating	14
MAINTENANCE	14
IDLER MOUNTING	
Troughed Idler with Channel Spine	15
Troughed Idler with Pipe Spine	16
Flat Idler	17
MSI WIRING	18
OUTLINE DIMENSIONS - CEMA	19
OUTLINE DIMENSIONS - METRIC	20



## **ABOUT THIS MANUAL**

---

---

This instruction manual covers the installation, operation and maintenance of the MSI belt scale.

We strongly recommend that the user read this manual before installation and start up of any component of the weighing system to which the MSI is being applied. Adhering to the installation and operating procedures will insure a quick, trouble free installation and allow for the maximum accuracy and reliability of your weighing system.

Because the MSI belt scale is used in conjunction with an integrator and speed sensor, the instruction manuals covering these components should be read as well.

## **ABOUT THE MSI**

---

---

The Milltronics Single Idler (MSI) is a belt scale designed to be inserted into belt conveyors for continuous weighing of dry bulk solids.

The MSI belt scale includes:

- one weighbridge c/w two load cells with leads run in liquid tite conduit and 150 cm (5') of interconnecting cable terminated with lugs and conduit fitting.
- test weight(s)

The addition of an idler (supplied and installed by customer) to the weighbridge completes the weighing assembly. The MSI load cells provide an electronic signal, proportional to load, which is fed to the Milltronics integrator. Thus, weighing is accomplished without interrupting the process and without affecting the process material.

It is important to understand that the MSI is an accurate and repeatable force sensor. Its performance is ultimately dependent upon the conveyor system and the quality of the installation and alignment.

## SPECIFICATIONS

---

---

- Accuracy: »  $\pm 0.5\%$  of totalization over 5 to 1 operating range
- Belt Width: » 18" to 96" in CEMA sizes  
» 500 to 2000 mm in metric sizes  
» refer to Outline Dimensions section
- Belt Speed: » up to 4 m/s (800 fpm)
- Capacity: » up to 5000 TPH at maximum belt speed
- Conveyor Incline: »  $\pm 20^\circ$  from horizontal, fixed incline  
» up to  $\pm 30^\circ$  with reduced accuracy
- Conveyor Idler: » flat to  $35^\circ$   
» up to  $45^\circ$  with reduced accuracy
- Idler Diameter: » 50 to 180 mm (2 to 7")
- Idler Spacing: » 0.5 to 1.5 m (1.5 to 5.0 ft)
- Load Cell: » excitation: » 10 V dc nominal  
» 15 V dc maximum  
» output: » 2 mV / V excitation at rated load cell capacity  
» non-linearity: » 0.02% of rated output  
» hysteresis: » 0.02% of rated output  
» non-repeatability: » 0.01% of rated output  
» capacity: » maximum ranges: 50, 100, 250, 500, 750, 1000 lb  
» overload: » safe 150% of rated capacity  
» ultimate 300% of rated capacity  
» temperature: »  $-40$  to  $85^\circ\text{C}$  ( $-40$  to  $185^\circ\text{F}$ ) operating range  
»  $-18$  to  $65^\circ\text{C}$  ( $0$  to  $150^\circ\text{F}$ ) compensated  
» mounting dims: » identical for all capacities
- Approvals: » CSA certified for general purpose
- Hazardous Locations: » with the use of approved intrinsically safe barrier strips
- Weight: » see chart, Outline Dimensions section

**The combination of capacity, speed and idler spacing must result in a usable conveyor belt loading value.**

## OPERATION

The MSI weighbridge is designed to react only to the vertical component of the force being applied to it. The MSI consists essentially of a fixed support frame (static) and a live frame (dynamic).

The static frame is the main scale support between the conveyor stringers which in turn supports the dynamic frame including the load cells.

The dynamic frame supports the scale idler and transfers the weight of the material to the load cells.

As the material travels along the conveyor belt, a force is exerted through the suspended idler to the dynamic frame. The dynamic frame is forced down proportionally. The movement in the load cell is sensed by its strain gauges when excited by voltage from the electronic integrator and produces a signal proportional to weight, which is returned to the integrator. The movement in each load cell is limited by the positive stop incorporated in the design of the load cell.

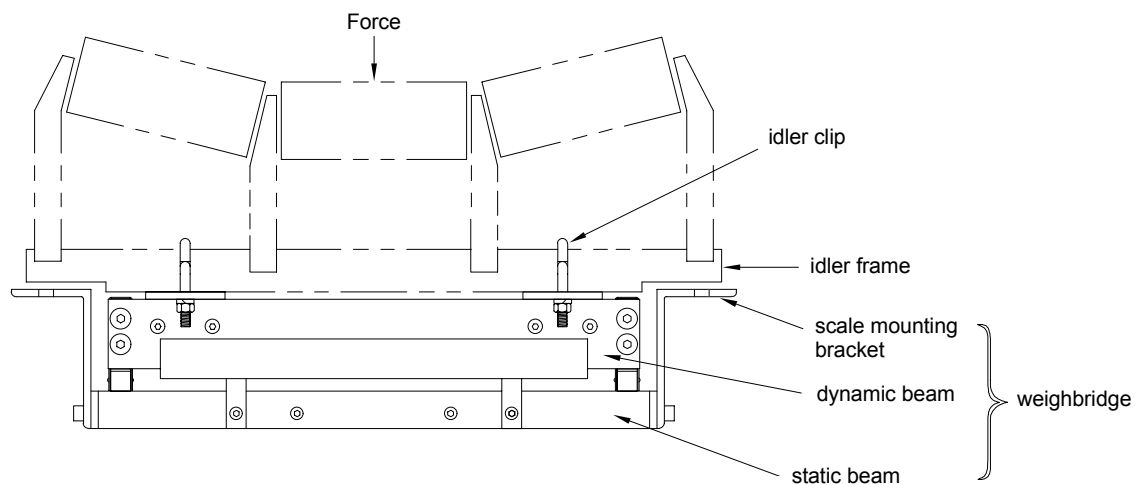
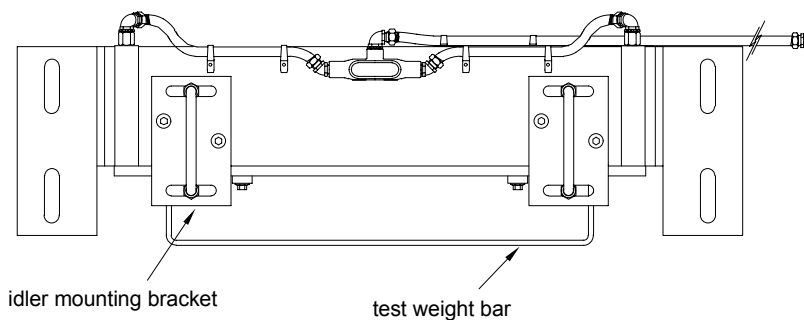

# INSTALLATION

---

---

## INTRODUCTION

The MSI is shipped from the factory as a single unit attached to a shipping frame for protection. The unit must be removed from its shipping frame and inspected for physical damage.

Be sure the conveyor design meets the installation requirements for the Milltronics MSI scale. The conveyor stringers must be rigid, straight, parallel to and square with the belt line in the area of the scale installation. The idler to be used on the scale and at least the next two approach and retreat idlers must be of the same style and manufacture and in good condition.

Prepare the site in accordance with the Milltronics drawing(s) provided or by reference to Milltronics instruction manual PL-264, Applications Guidelines.

## WELDING

Extreme caution should be used when arc welding in the area of the belt scale. Be sure that no welding current can flow through the belt scale. Welding currents through the scale are sufficient to functionally damage the load cells.

## LOAD CELL HANDLING

The load cell can tolerate very little negative displacement, without damaging the load cell.

When handling the MSI, install both shipping stops to their vertical position to protect the load cells. Do not lift the MSI by the dynamic frame or subject it to shock from blows of a hammer when trying to position it.

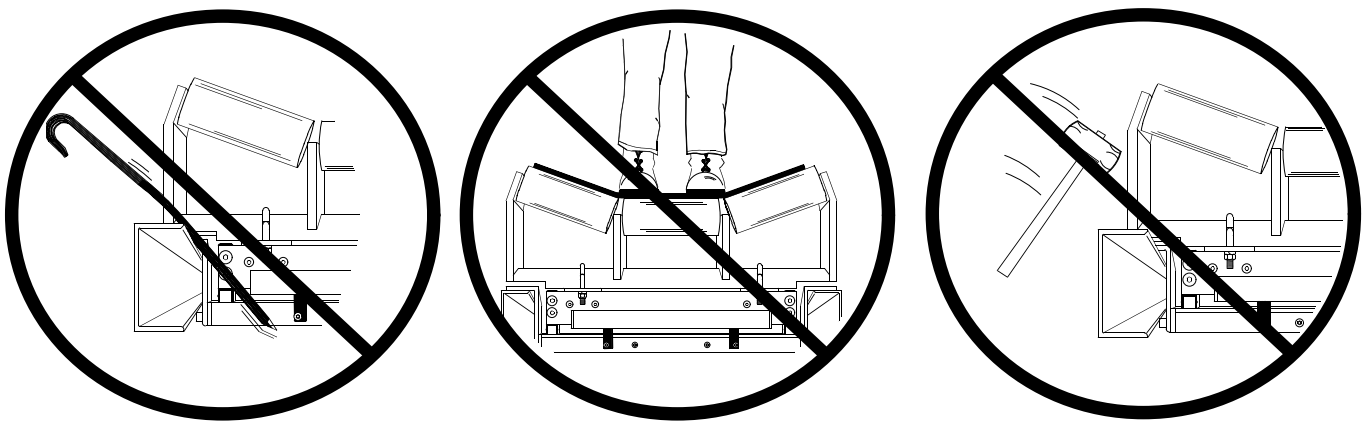

**DO NOT STAND OR WALK ON THE SCALE.  
OVERLOADING, SHOCK AND TWISTING OF THE SCALE CAN  
DAMAGE THE LOAD CELLS.**



## INSTALLATION PROCEDURE

1. Remove the conveyor idler currently at the desired point of installation.

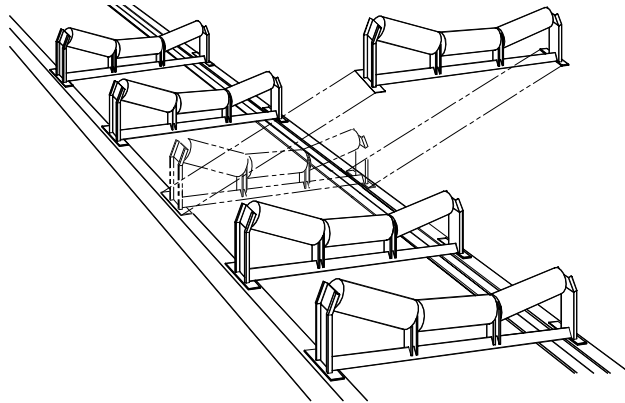

2. Remove the idler foot plate and modify the idler frame at both ends of the idler as shown below.

( Occasionally (in less than 5% of applications) the combined effect of the idler rework and the clamping of the scale at its inboard mounting position could result in abnormal idler vibration. When this occurs gusset plate reinforcements should be welded to the idler at the joints of the horizontal spine and the outer vertical leg member. See Idler Mounting section for further details. )

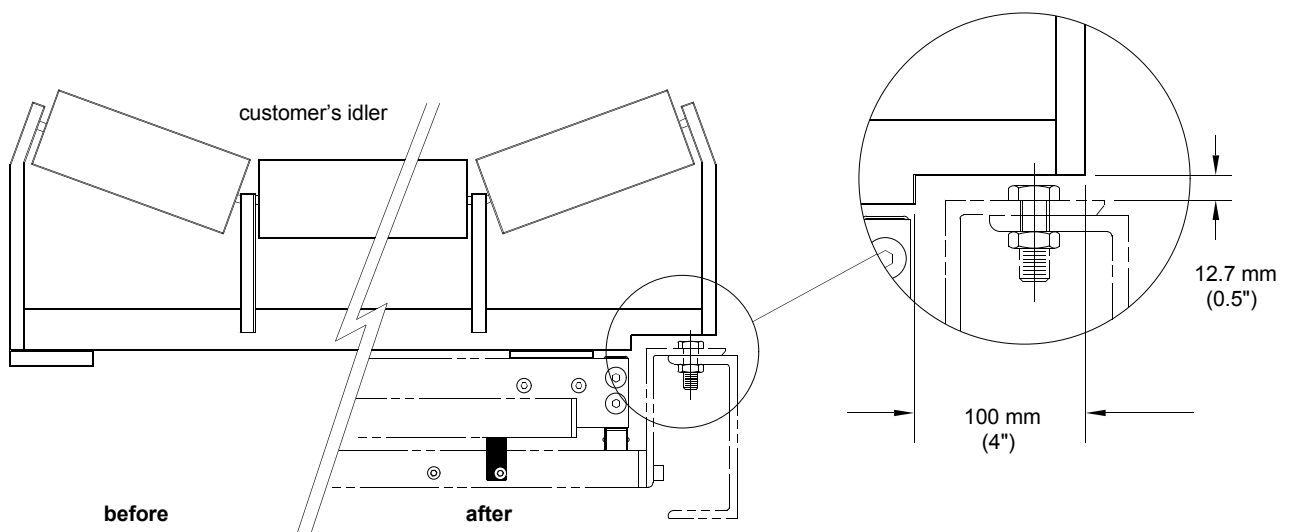

Typical Troughed Idler  
For other types, refer to Idler Mounting section.

3. Insert the MSI in the place of the removed idler. The MSI is designed to use the existing holes in the stringer and should not require further drilling. Install the mounting bolts and nuts but do not tighten. Remove the idler clips from the scale (see diagram below). Refer to Outline Dimensions section for working dimensions.

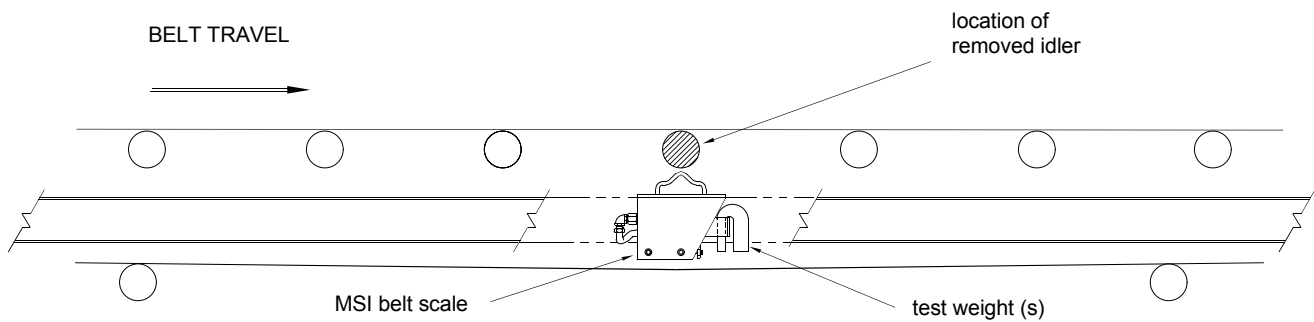

Be sure there is sufficient clearance between the return belt, the MSI, and its test weight ( when used during the calibration procedure ).

4. Position the scale so that it is centered and square to the stringer. Mount the modified idler so that it is centered on the scale using the idler clips. Tighten all mounting hardware.

Position the scale so that the large arrow on the scale mounting brackets is pointing in the direction of belt travel.

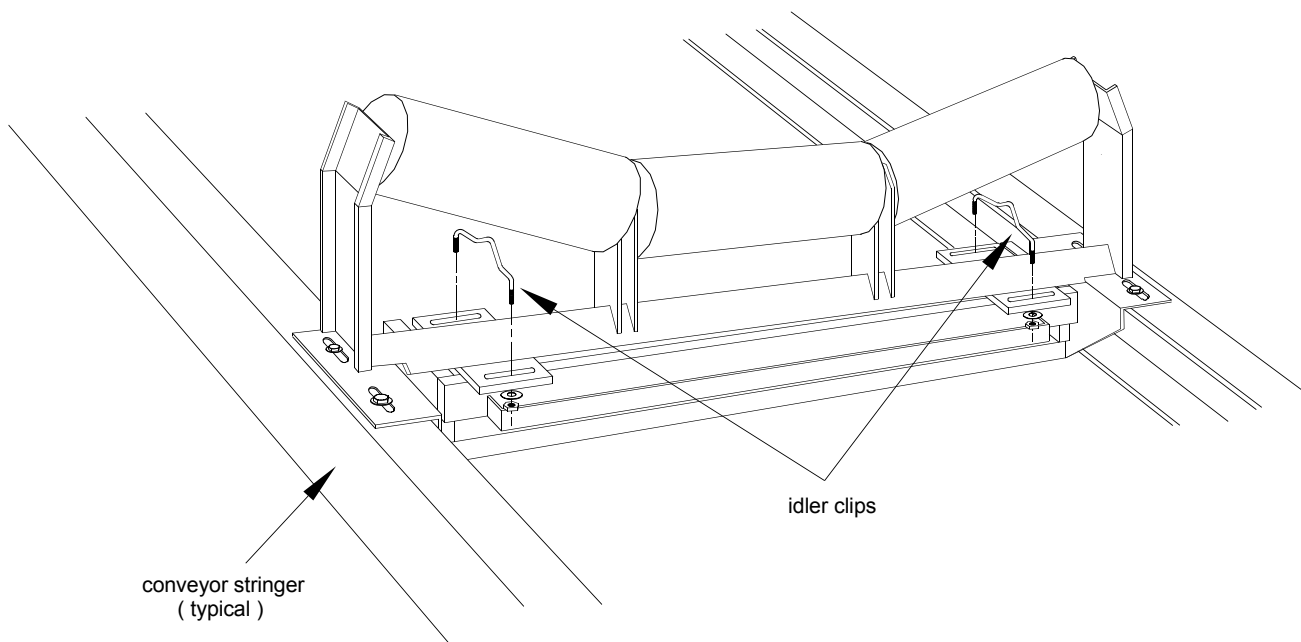

- Release the shipping stops in order to free the weighing mechanism. Loosen screws 'A' and rotate both shipping stops inward until the underside slots slide around the screws 'B'. Tighten screws 'A' to secure in place.

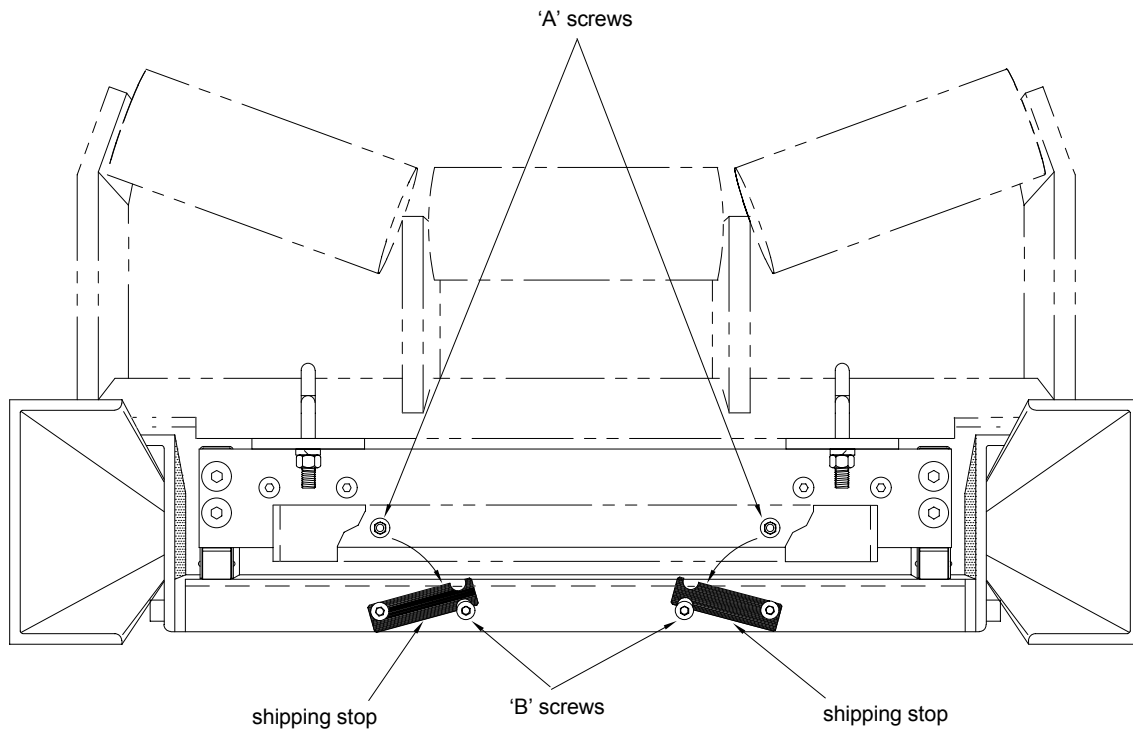

- The idlers in the weighing area must be properly aligned and leveled by shimming the scale idler, the two approach and the two retreat idlers until they are within  $\pm 0.8$  mm ( $1/32$ ") of each other. Be sure to check that the idlers are centered and squared to the conveyor during the shimming process.

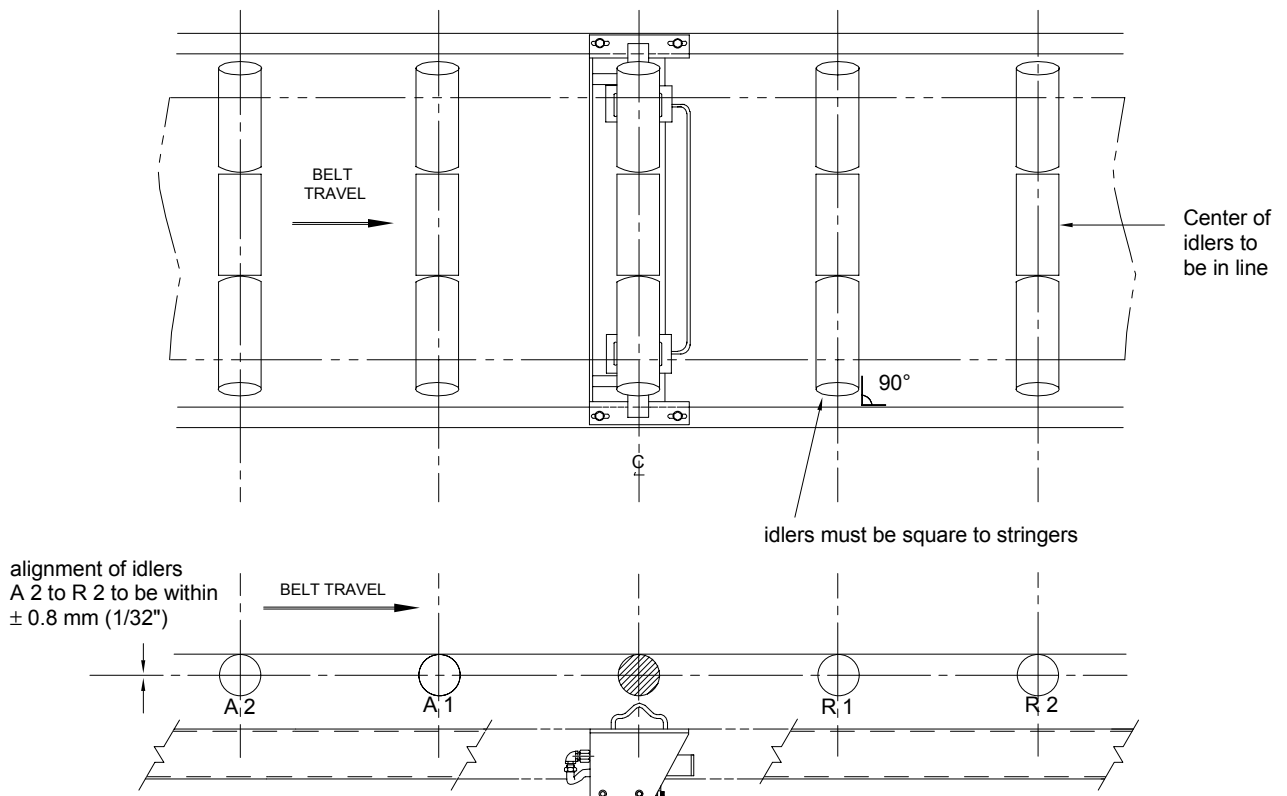

7. Precise idler alignment is very important if maximum accuracy of the weighing system is to be achieved. Misaligned idlers will result in unwanted forces being applied on each idler in the weighing area, causing calibration and measurement errors. Use a good quality wire or string to check for alignment. The wire or string must be able to withstand sufficient tension in order to eliminate any sag. Adjust shims so that all rolls of the A2 through to the R2 idlers are in line within  $\pm 0.8$  mm ( $1/32$ ").

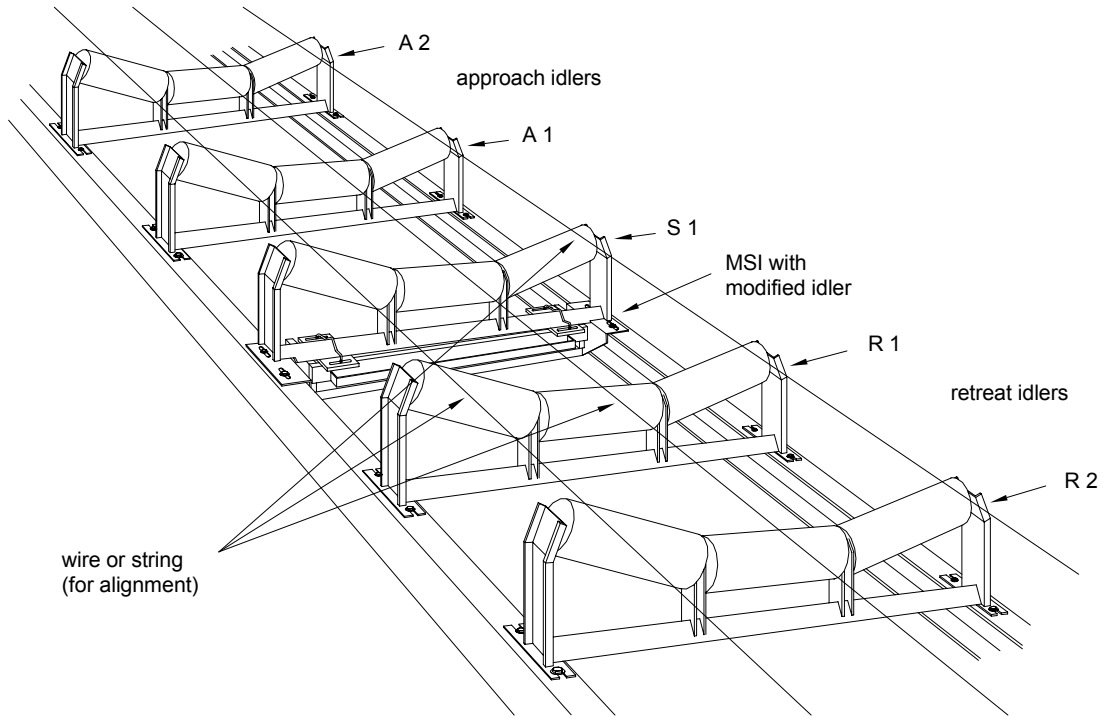

Although the accepted tolerance for idler alignment is  $\pm 0.8$  mm ( $1/32$ " ), the scale mounted idler should never be lower than the adjacent idlers. Establishing good idler alignment is the most important part of the installation procedure. Scale accuracy is directly affected by alignment. Proper attention must be given here.

# CALIBRATION

---

## GENERAL

After the MSI has been properly installed, calibration of the weighing system must be done in conjunction with the integrator. Refer to the integrator instruction manual for programming and calibration. The calibration is initially done using the supplied test load. Material tests are recommended to achieve maximum accuracy.

## TEST LOAD

The test load value for your MSI is given on the accompanying data sheet. The value is to be entered into the dedicated programming parameter of the integrator, in kilograms per meter or pounds per foot.

If the actual idler spacing differs from that recorded on the design data sheet, the test load must be recalculated as follows. Failure to do so will cause the design test load value to be in error.

$$\text{test load} = \frac{\text{Total weight of all test weights}}{\text{idler spacing}} \left( \frac{\text{kg}}{\text{m}} \right) \text{ or } \left( \frac{\text{lb}}{\text{ft}} \right)$$

## ZERO

Perform the zero calibration as described in the Calibration section of the integrator manual.

## SPAN

The test load used in the calibration procedure is a set of factory sized and supplied test weights ( 1 to 12 ).

The test weights are all to be placed on the test weight bar as shown.

Perform the span calibration as described in the Calibration section of the integrator instruction manual.

After the span calibration has been completed, remove the test load and store it.

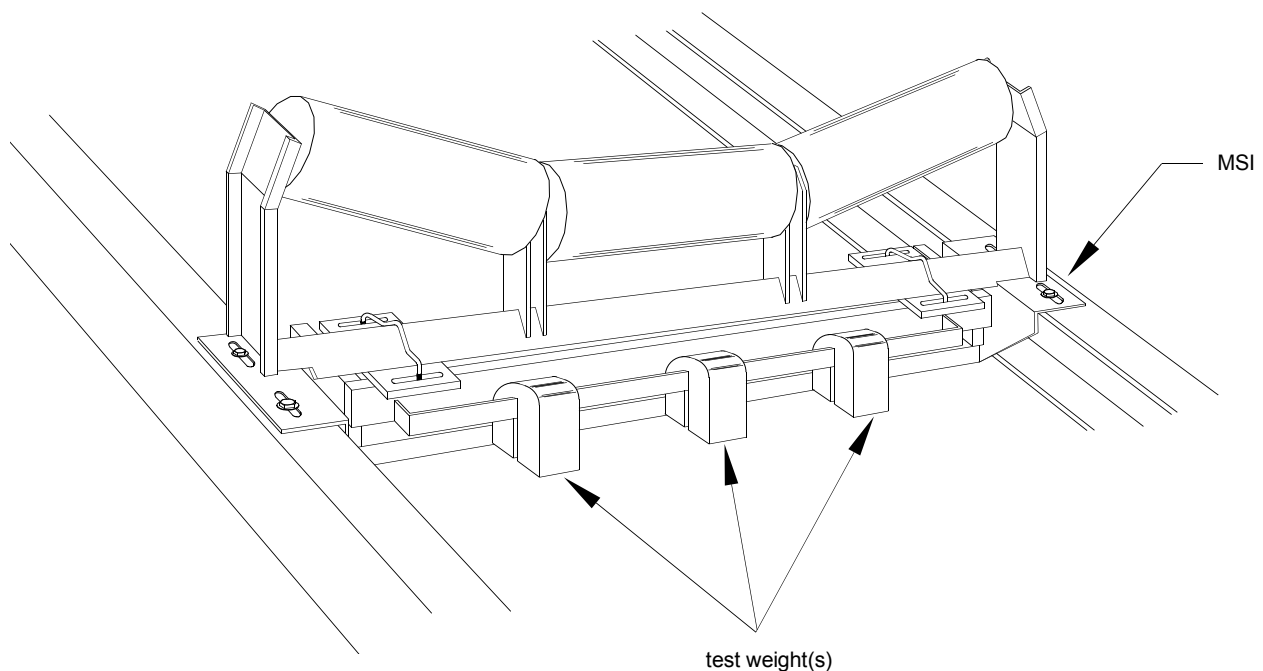

## **MATERIAL TEST**

The MSI is guaranteed to be accurate to +/- 1/2% when installed on a conveyor in accordance with this manual and meeting the qualifications outlined in Manual PL 264 "Applications Guidelines". This guarantee is based on calibrations performed using the test weights furnished with the scale and as referenced on the previous page.

When the existing conditions are such that the installation of the scale cannot meet the above mentioned requirements for an approved installation it is recommended that Material tests be performed. This will enable the user to compare the present scale results to the results of the material tests. The scale is then adjusted or factored so that subsequent scale calibrations with test weights will agree with actual run of material.

## **RE-RATING**

Any significant change in rate, speed and /or idler spacing from original design specifications should be referred to your local Milltronics office to be sure that proper design parameters are maintained.

## **MAINTENANCE**

---

---

Due to the simplified design and the lack of moving parts, the MSI itself requires no active maintenance. The scale weighbridge should be kept clean. Accumulation of material between the fixed support frame (static) and the live frame (dynamic) as well as around each load cell could affect the scale accuracy. Periodically check the alignment of the stringers and idlers in the weighing area.

The conveyor on the other hand requires more attention since it is now part of the total weighing system. When a problem arises in the conveyor, it is possible that the scale will be affected. Therefore, periodic conveyor maintenance is important to proper scale operation which should include:

- » lubrication of all pulleys and idlers
- » proper belt tracking and training
- » proper belt cleaning and scraping
- » proper take up operation
- » proper material feeding and spillage control

Maintenance precautions :

- » When welding near the scale do not allow current to pass through the belt scale.
- » Reset the shipping stops to reduce physical shock to the load cells during maintenance.
- » Recalibrate the scale after maintenance and prior to use.

# IDLER MOUNTING

The MSI is usually installed in conveyors employing conventional rigid structure idlers. Within this type of idler, construction will vary depending on the manufacture and the application. The idler depicted in the Installation Procedure uses an angle iron spine. The following depicts alternate idler construction and tips on how they should be modified and installed.

## TROUGHED IDLER WITH CHANNEL SPINE

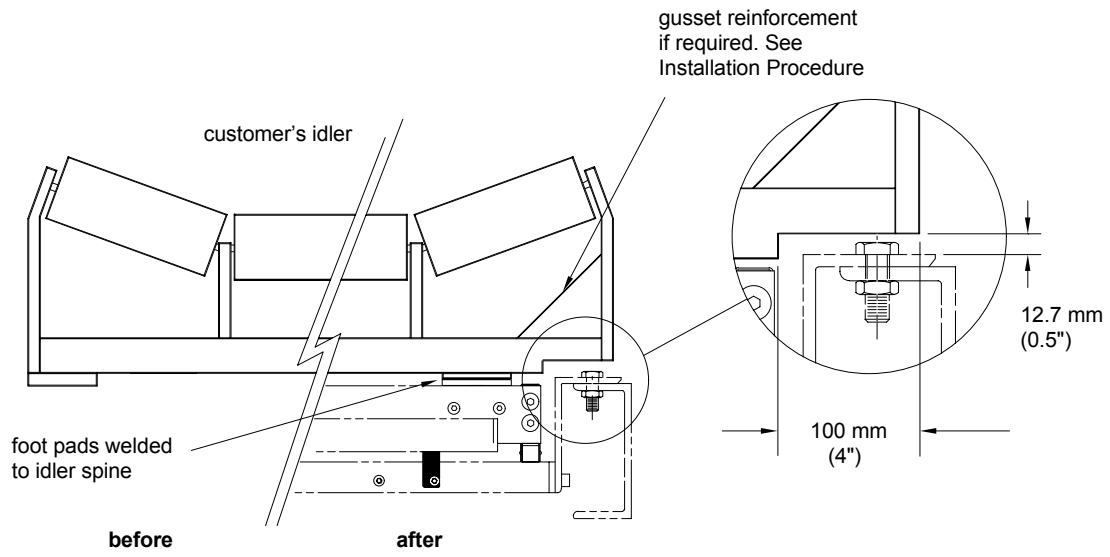

## idler modification

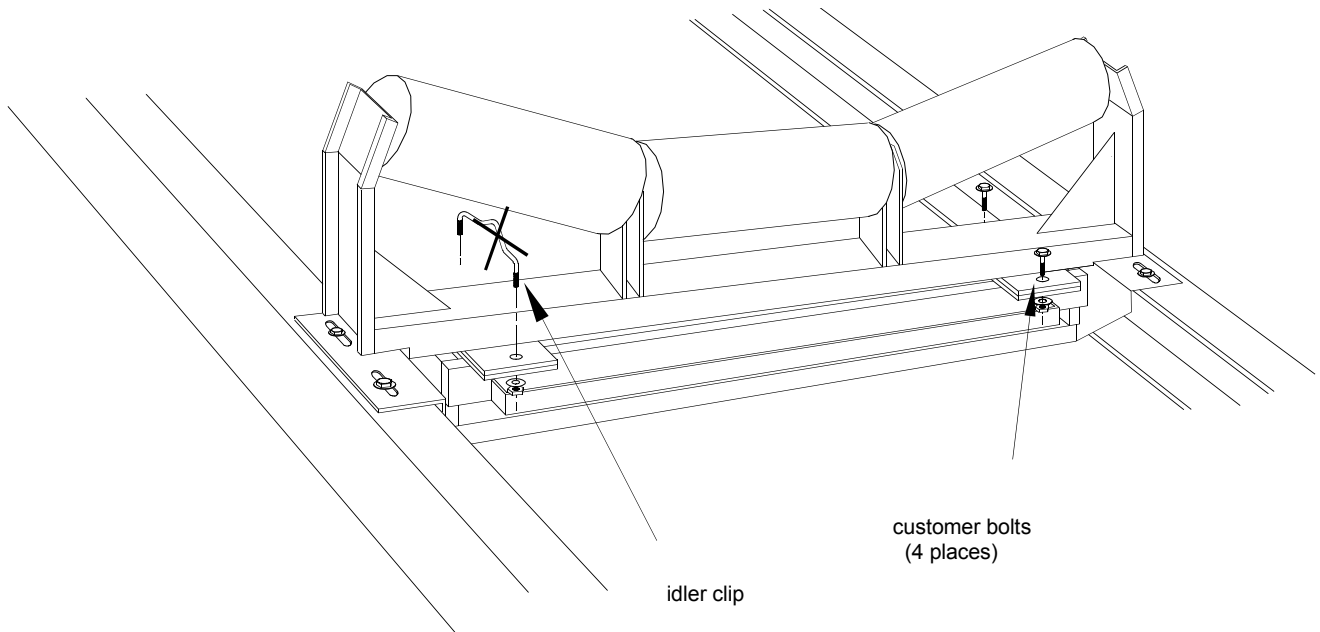

## idler installation

# TROUGHED IDLER WITH PIPE SPINE

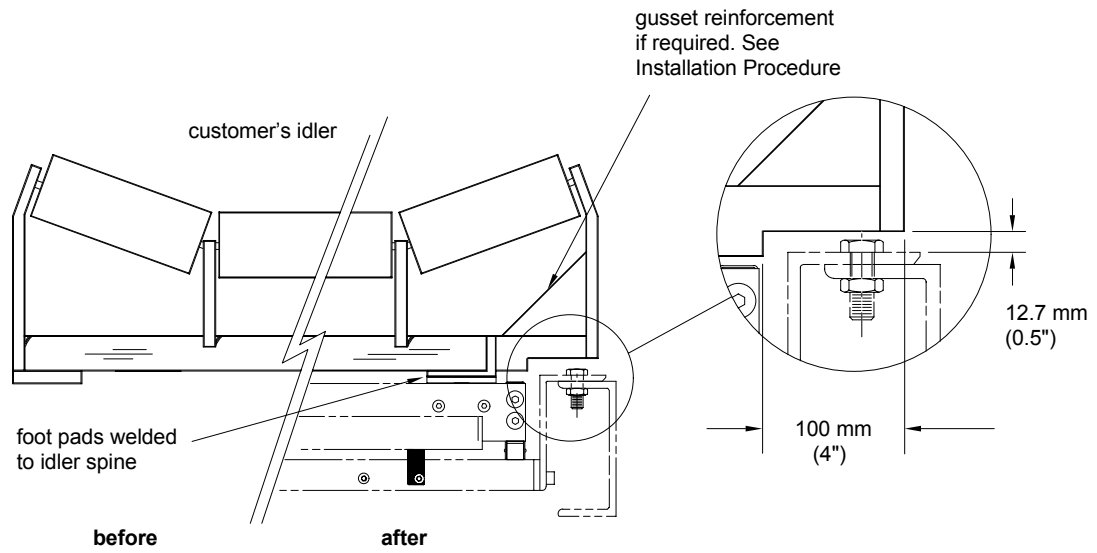

## idler modification

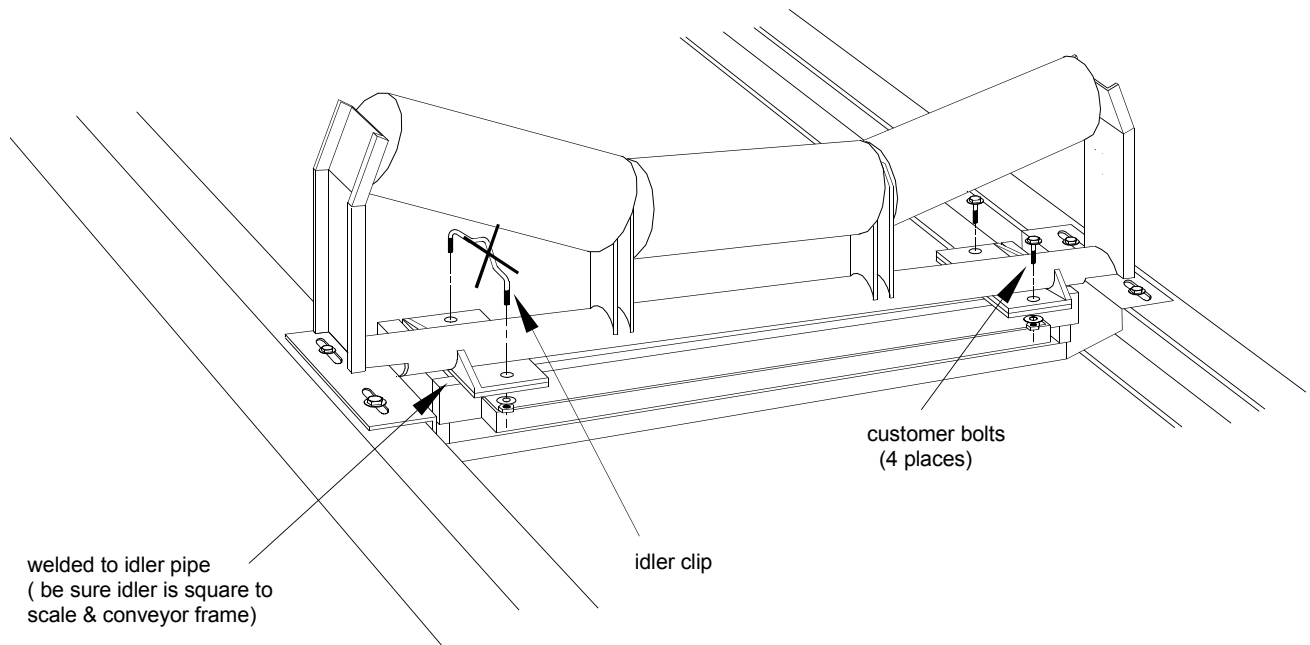

## idler installation



# FLAT IDLER

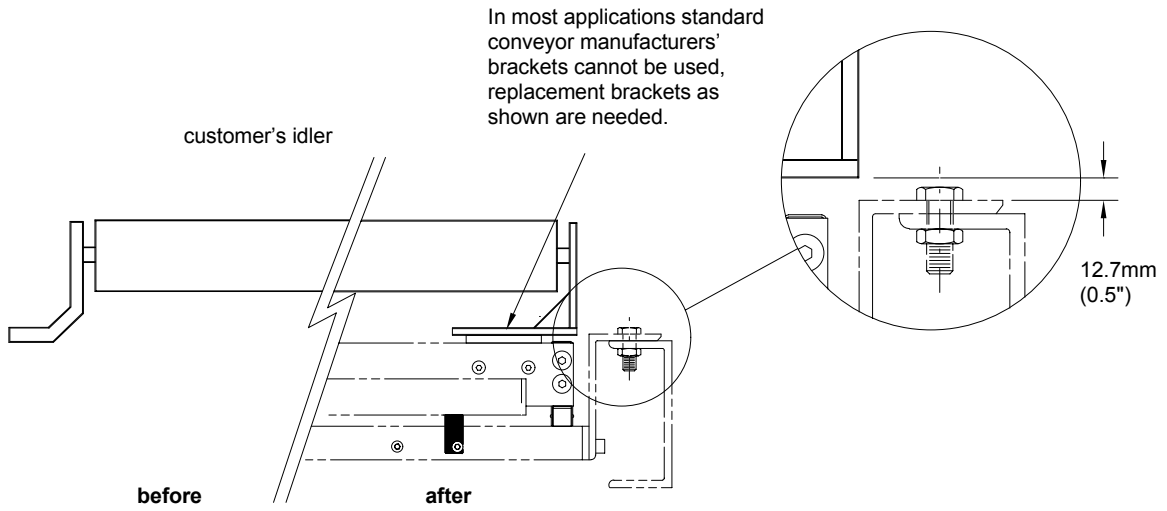

## idler modification

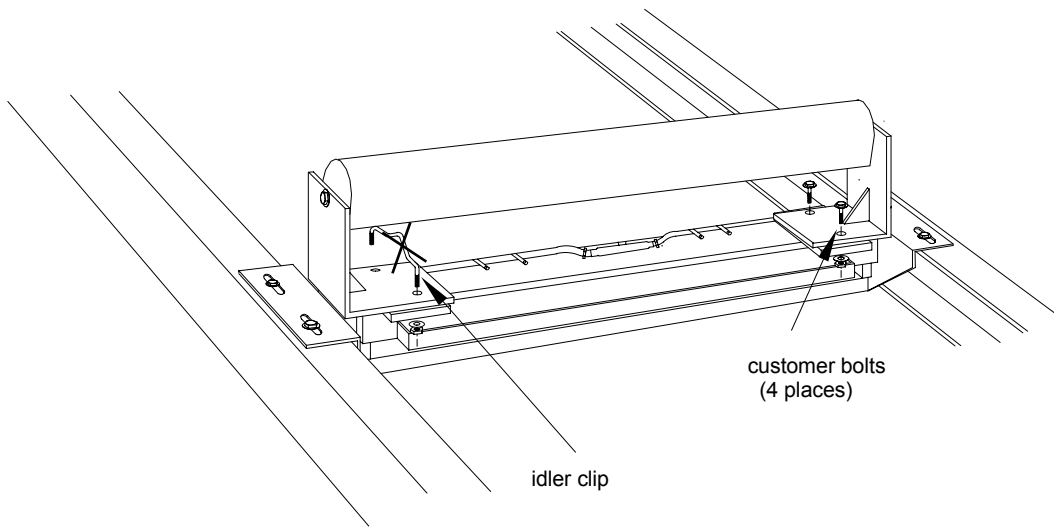

## idler installation

# MSI WIRING

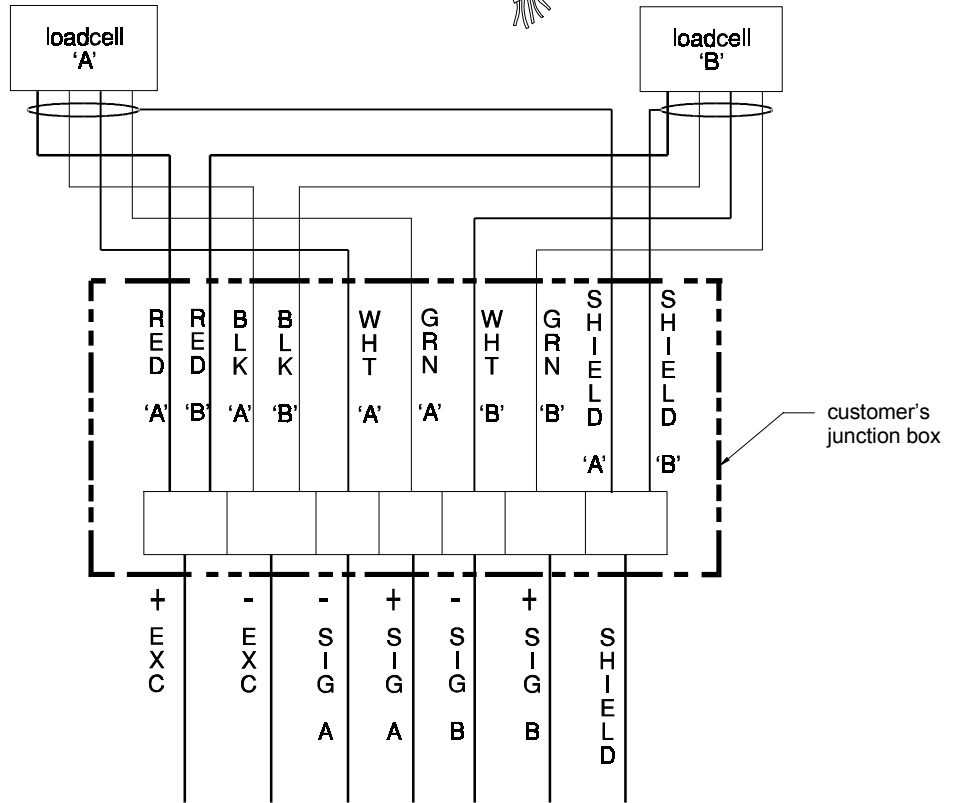
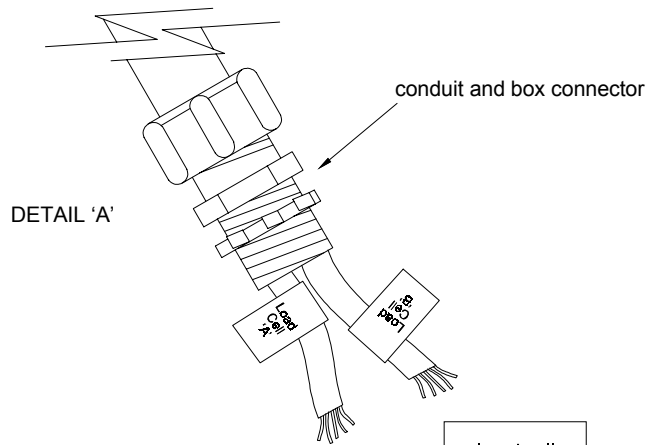
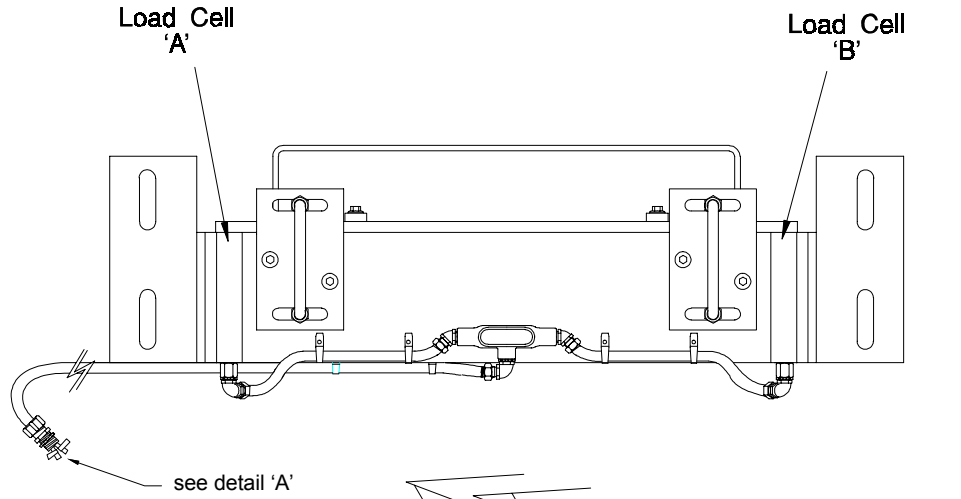

to integrator

# OUTLINE DIMENSIONS - CEMA

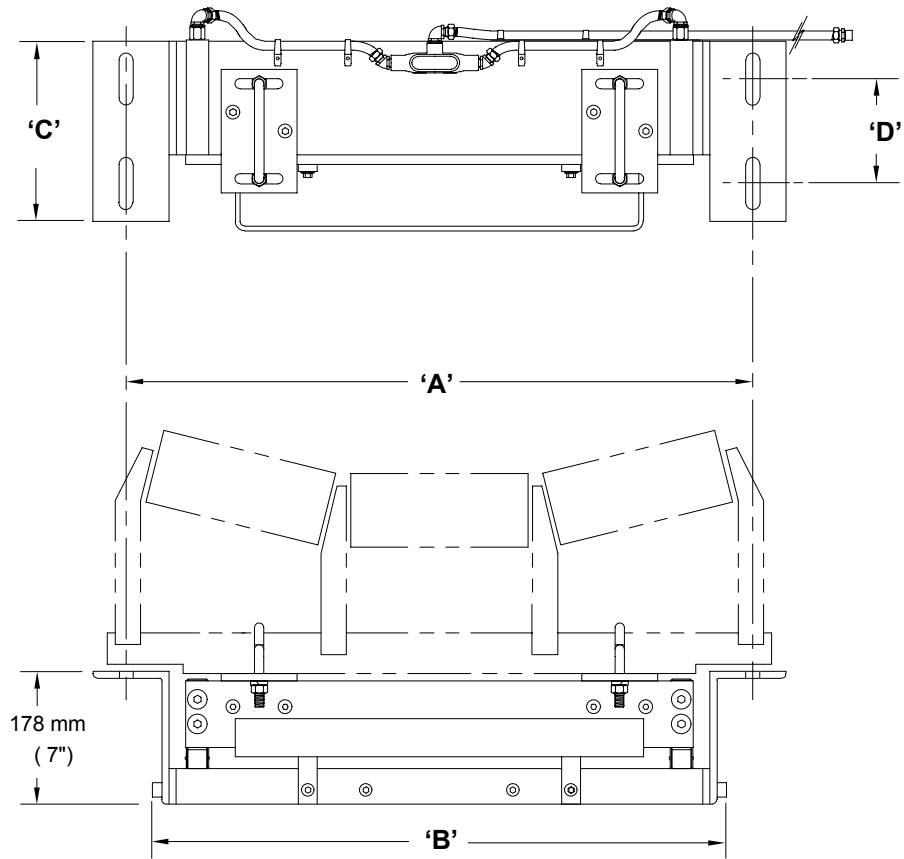

conveyor belt width	mounting scale width 'A'	minimum drop-in width 'B'	'C'	'D'	weight
18 "	27 "	24.5 "	9.5 "	5.5 "	82 lb
20 "	29 "	26.5 "	9.5 "	5.5 "	85 lb
24 "	33 "	30.5 "	9.5 "	5.5 "	90 lb
30 "	39 "	36.5 "	9.5 "	5.5 "	99 lb
36 "	45 "	42.5 "	9.5 "	5.5 "	107 lb
42 "	51 "	48.5 "	9.5 "	5.5 "	116 lb
48 "	57 "	54.5 "	12 "	8 "	162 lb
54 "	63 "	60.5 "	12 "	8 "	174 lb
60 "	69 "	66.5 "	12 "	8 "	185 lb
72 "	81 "	78.75 "	12 "	8 "	235 lb
84 "	93 "	90.75 "	12 "	8 "	261 lb
96 "	105 "	102.75 "	12 "	8 "	288 lb

# OUTLINE DIMENSIONS - METRIC

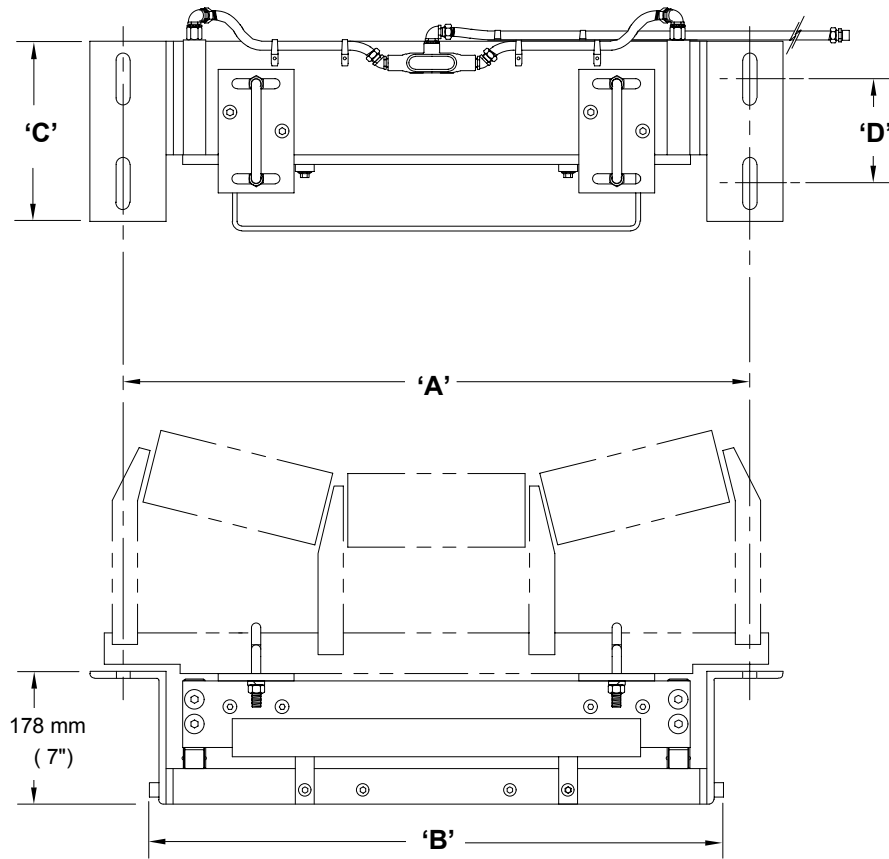

conveyor belt width	mounting scale width 'A'	minimum drop-in width 'B'	'C'	'D'	weight
500 mm	740 mm	677 mm	241 mm	140 mm	37 kg
650 mm	890 mm	827 mm	241 mm	140 mm	40 kg
800 mm	1040 mm	977 mm	241 mm	140 mm	44 kg
800 mm	1090 mm	1027 mm	241 mm	140 mm	48 kg
1000 mm	1240 mm	1177 mm	241 mm	140 mm	52 kg
1000 mm	1290 mm	1227 mm	305 mm	203 mm	73 kg
1200 mm	1450 mm	1387 mm	305 mm	203 mm	78 kg
1200 mm	1540 mm	1477 mm	305 mm	203 mm	83 kg
1400 mm	1650 / 1740 mm	1587 / 1677 mm	305 mm	203 mm	88 kg
1600 mm	1900 / 1940 mm	1837 / 1877 mm	305 mm	203 mm	93 kg
1800 mm	2100 / 2140 mm	2037 / 2077 mm	305 mm	203 mm	98 kg
2000 mm	2300 / 2340 mm	2237 / 2277 mm	305 mm	203 mm	103 kg

www.milltronics.com

**MILLTRONICS**

Siemens Milltronics Process Instruments Inc.  
1954 Technology Drive, P.O. Box 4225  
Peterborough, ON, Canada K9J 7B1  
Tel: (705) 745-2431 Fax: (705) 741-0466  
www.milltronics.com

© Siemens Milltronics Process Instruments Inc. 2001  
Subject to change without prior notice



Printed in Canada