

MMI Belt Scale

For Outstanding Accuracy



 **MILLTRONICS**
Mass Dynamics Division



Cost Effective, High Accuracy In-Line Weighing

Milltronics' MMI Multi Idler belt scale consists of two or more MSI single idler belt scales installed in series. Suitable for providing high accuracy, in line weighing on a variety of products in primary and secondary industries, the MMI monitors products as diverse as aggregate, fertilizer, grain or coal. It is internationally proven in a wide range of tough applications from extraction - in mines, quarries and pits - to power generation, iron and steel, food processing and chemicals.



Field Proven Technology

Milltronics' MMI Belt Scale delivers the world beating reliability needed for effective dynamic in-line weighing of material on belt conveyors, even in the harshest environments.

The MMI links in to a range of advanced electronic integrators to provide site management with continuous readouts of rate, total, speed and load.

The unbeatable combination of simple installation, low maintenance and high accuracy makes Milltronics' MMI the preferred choice for in-line belt weighing of bulk solids.

High Accuracy and Repeatability

The MMI system is NTEP approved, certifiable for trade. Milltronics' unique weigh frame design ensures unrivalled accuracy and repeatability even in applications with uneven or light product loading, short idler spacing and fast belt speeds.

The MMI system provides accuracies of $\pm 0.25\%$ with superior repeatability.

Simple Installation

This compact belt scale can be used in conveyors where space is restricted. Because of its simple drop-in installation, significant cost savings are offered over conventional systems. The weigh frames are easily mounted in the conveyor by just four bolts and an existing idler set, then secured to the dynamic beam. Installation is quick and easy, taking just a matter of hours.

Low Cost of Ownership

Since the MMI has no moving parts, potential maintenance problems associated with wear on pivot and lever components are eliminated. A periodic calibration check is the only maintenance that may be required. Mechanical stops protect the system against accidental overload, preventing costly damage.



Fast Reaction to Product Loading

The patented design of the MMI is unlike that of any other belt scale design. Its unique use of parallelogram style load cells results in fast reaction to vertical forces, ensuring instant response to changes in product loading. This guarantees outstanding accuracy and, more importantly, repeatability. This is true even in applications with uneven product loading or with relatively fast moving belts.

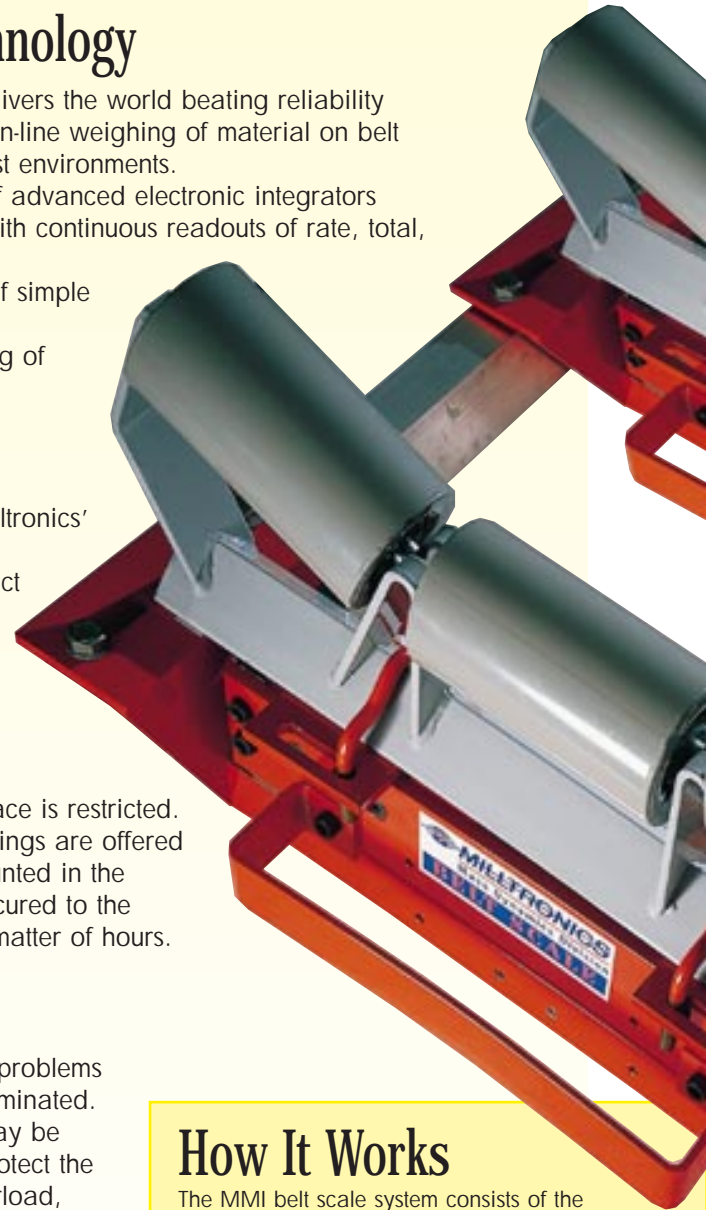

How It Works

The MMI belt scale system consists of the following components: multiple weighbridges, a speed sensor, and a microprocessor based integrator. Each weighbridge has a rigid steel base which supports two electronically balanced load cells. The parallelogram design of the load cells allows them to react only to vertical forces transmitted through the weighing idler. This virtually eliminates the effects of idler friction, side forces or off-centre belt loading. This response, only to actual belt loading, makes the MMI the most accurate multiple idler belt scale available. In operation, the vertical force representing the actual belt load is sensed by the load cells, providing the weight signal. A shaft mounted speed sensor provides a signal for belt speed. The integrator processes these signals and provides indication of and outputs for flow rate and totalized material weight.

Integrator Options to Suit Your Needs

Milltronics' belt scales operate in conjunction with one of a series of microprocessor-based integrators which provide information in the format you require. These integrators indicate flow rate, total weight, belt load and speed of bulk solids material on easy-to-read displays.

Options include the provision of a bar graph showing percentage of rate, enabling an operator to assess production against target at a glance. Integrators are capable of handling multiple load cell inputs. We will help you make the choice of integrator to meet your specific needs.

Milltronics' integrators feature push button programming and operation, with automatic calibration through keypad data entry. Access protection to safeguard calibration is standard on all integrators, with memory protection giving extra data security. Data is displayed in standard engineering units.

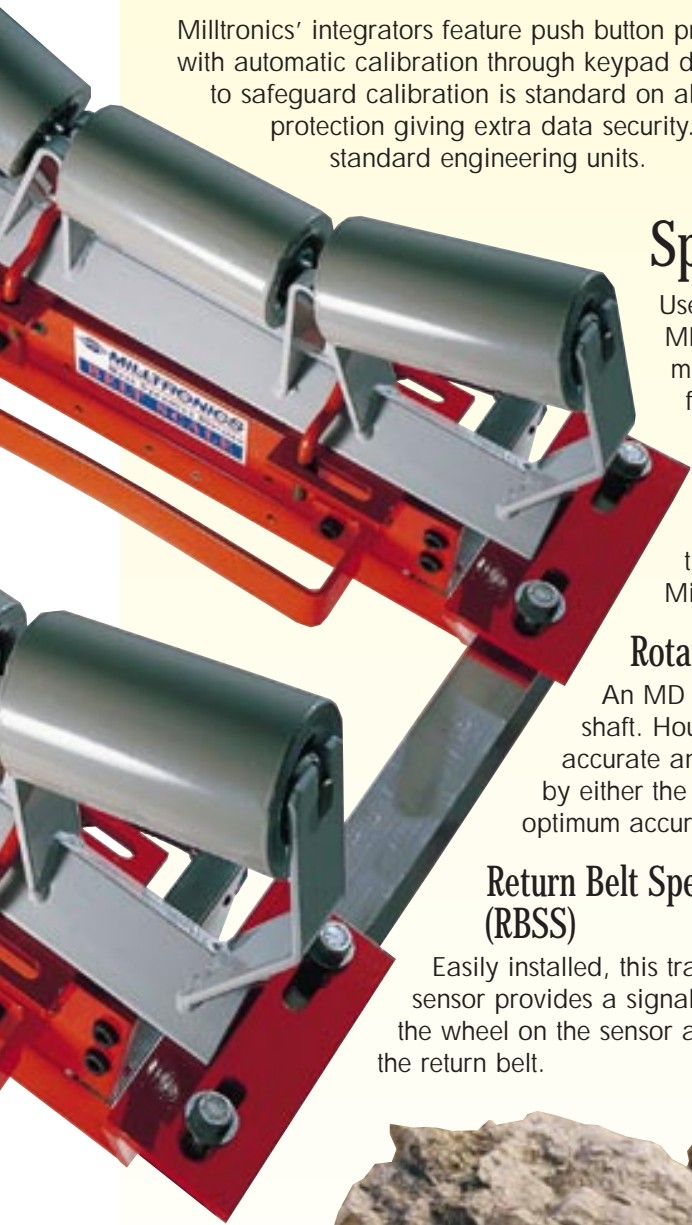

Speed Sensors

Used in conjunction with the MMI, the speed sensor monitors conveyor belt speed for input to the integrator.

The output signal is transmitted by cable connection to the integrator in order to accurately compute the rate of material being conveyed.

Milltronics offers the following speed sensor options:

Rotary Pulse Generator (MD Series)

An MD Series model mounts directly to the tail or bend pulley shaft. Housed in a rugged, weatherproof enclosure, it provides accurate and reliable results. It is immune to false signals generated by either the conveyor or external vibrations, essential for optimum accuracy.

Return Belt Speed Sensor (RBSS)

Easily installed, this trailing arm speed sensor provides a signal generated from the wheel on the sensor as it rotates on the return belt.



Specifications

Accuracy	± 0.25% of totalized weight over a range of 0.25 to 1.25 of design capacity on an approved installation.	Weigh Bridge Construction	Structural steel, supporting two load cells. Optional stainless steel.
Standard Size	For conveyors with belt widths from 500mm to 1800mm (metric). From 18 in. to 60 in. (CEMA).	Overload Protection	Infinite (mechanical stop).
Mounting	Four bolts per weighbridge, two for each conveyor stringer. Designed to fit any standard conveyor.	Calibration	Via static test weights (supplied), test chains (optional), or material tests.
		Load Cell	Super precision strain gauge, temperature compensated.
		Operating Range	-40° to 60°C (-40° to 140°F)

Shipping weight 100 kg (220 lbs.) maximum per weigh bridge.
Standard components include belt weigh bridges, speed sensor, test weights, integrator and packaging.

MMI Dimensions

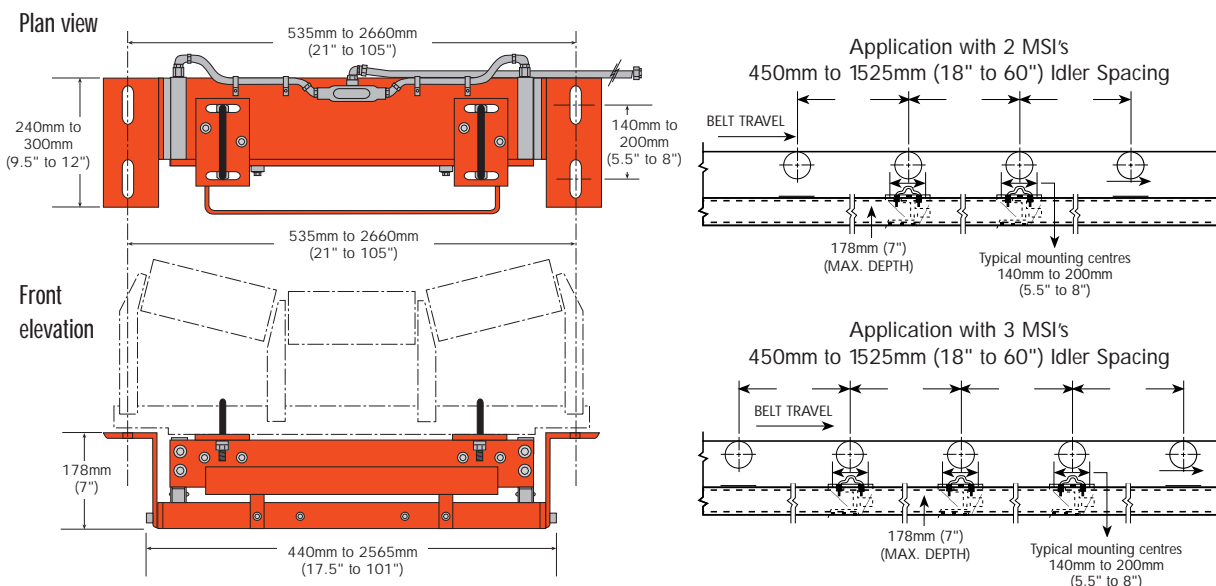

Our continuous program to improve our products may result in changes to design and specifications without notice.

Y2K Compliant - Year 2000 Compliant

Mass Dynamics is dedicated to the sales and development of continuous weighing, feeding and motion sensing instrumentation. Launched in 1997 as a new business division of Milltronics Ltd., Mass Dynamics offers a range of belt scales, solids flowmeters, weigh feeders, acoustic sensors and motion sensing equipment. Designed to withstand the sustained rigours of heavy primary industries, these products have proven their reliability in a wide range of harsh applications including the mining, mineral processing and cement industries. They are also used extensively in wet and dry food processing and petrochemicals.



1954 Technology Dr., P.O. Box 4225, Peterborough, Ont., Canada K9J 7B1
Tel.: +1 705-745-2431 Fax: +1 705-741-0466

182 Normanby Rd., Box 339, South Melbourne, 3205, Australia
Tel.: +011-613-9695-2400 Fax: +011-613-9695-2450

August van de Wielelel 97, 2100 Deurne, Antwerp, Belgium
Tel.: +32(0)3326 45 54 Fax: +32(0)3326 05 25

Century House, Bridgwater Road, Worcester, England WR4 9ZQ
Tel.: +44 1905-450500 Fax: +44 1905-450501

Parc de la Sainte Victoire, Bat. 5, 13590 Meyreuil, France
Tel.: +33 4 42 65 69 00 Fax: +33 4 42 58 63 95

Werfstrasse 47, D.40549 Dusseldorf, Germany
Tel.: +49 211 562 5025 Fax: +49 211 562 6030

1 Hoi Wan Street, Suite 602, Quarry Bay, Hong Kong
Tel.: +011 852-2856-3166 Fax: +011 852-2856-2962

Amores No. 1155, Col. del Valle, 03100 Mexico D.F., Mexico
Tel.: +52 5 575-27-28 Fax: +52 5 575-26-86

Nikkelstraat 10, NL-4823 AB Breda, The Netherlands
Tel.: +31(0)76 542 7 542 Fax: +31(0)76 542 8 542

709 Stadium Drive, Arlington, Texas U.S.A. 76011
Tel.: +1 817-277-3543 Fax: +1 817-277-3894



Representative