

1. TABLE OF CONTENTS

1.	TABLE OF CONTENTS	1
2.	GENERAL INFORMATION.....	3
2.1.	EQUIPMENT	3
2.2.	STANDARD SPECIFICATIONS.....	4
2.2.1.	MODEL CODE	5
2.3.	PRINCIPLE OF MEASUREMENT.....	7
2.4.	SENSOR DESCRIPTION	8
2.5.	THE INDICATING TRANSMITTER	9
2.6.	DISPLAY AND KEYBOARD	10
2.7.	INFORMATION DISPLAY	12
2.8.	CALIBRATE.....	13
2.9.	COMPATIBILITY WITH K-PATENTS PROCESS REFRACTOMETER PR-01	15
2.10.	PROGRAM VERSIONS	16
2.11.	PASSWORD	16
2.12.	WARRANTY	16
3.	MOUNTING	17
3.1.	SENSOR LOCATION	17
3.2.	MOUNTING EXAMPLES	18
3.3.	MOUNTING OF SENSOR	21
3.4.	WASH NOZZLES.....	21
3.5.	INDICATING TRANSMITTER.....	21
3.6.	ELECTRICAL CONNECTIONS.....	21
3.7.	SERIAL OUTPUT	24
3.8.	FUSES	27
4.	START UP	28
4.1.	INITIAL CHECK.....	28
4.2.	CALIBRATION CHECK.....	29
4.3.	DEMO MODE.....	30
5.	CALIBRATION	31
5.1.	OUTPUT CURRENT RANGE SELECTION	31
5.2.	CONCENTRATION CALIBRATION FROM KEYBOARD.....	31
5.3.	FIELD CALIBRATION	31
5.4.	BENCH CALIBRATION.....	32
5.5.	MECHANICAL ZERO ADJUSTMENT	33
5.6.	SENSOR RANGEABILITY	34
5.7.	EEPROM PARAMETERS	34
5.8.	TEMPERATURE CALIBRATION	35
5.9.	INSTRUMENT VERIFICATION.....	35
5.9.1.	DEFINITIONS	35
5.9.2.	VERIFICATION OF REFRACTIVE INDEX (R.I.) CALIBRATION.....	36
5.9.3.	CORRECTIVE ACTION IF THE VERIFICATION FAILS.....	36
6.	MAINTENANCE.....	38
6.1.	REGULAR MAINTENANCE	38
6.2.	DIAGNOSTICS.....	38
6.3.	DISPLAY MESSAGES	41
6.4.	INDICATING TRANSMITTER.....	46
6.5.	SENSOR CHECK	52
6.6.	TEMPERATURE MEASUREMENT	58
6.7.	PRISM GASKET REPLACEMENT.....	58

PR-03 PARTS LISTS	62
7.1. SENSOR.....	62
7.2. INDICATING TRANSMITTER.....	64
8. PRISM WASH SYSTEMS	65
8.1. PRISM COATING	65
8.2. RECOMMENDED WASH PRESSURES AND TIMES.....	65
8.3. PRISM WASH NOZZLES.....	66
8.4. STEAM AND WATER WASH SYSTEMS	67
8.5. HIGH PRESSURE WATER WASH SYSTEM.....	67
9. RELAY UNITS	74
9.1. CONNECTIONS.....	75
9.2. RELAY CONFIGURATION.....	76
9.3. WASH LOGICS AND SMART WASH.....	77
10. ACCESSORY UNITS	80
10.1. EXTERNAL OUTPUT UNIT PR-7090.....	80
11. K-PATENTS SANITARY REFRACTOMETER CALIBRATION DATA REPORT	82

2. GENERAL INFORMATION

2.1. EQUIPMENT

The K-Patents Sanitary Refractometer consists of three parts (Figure 2.10): the Sensor (A), the Interconnecting Cable (B) and the Indicating Transmitter (C).

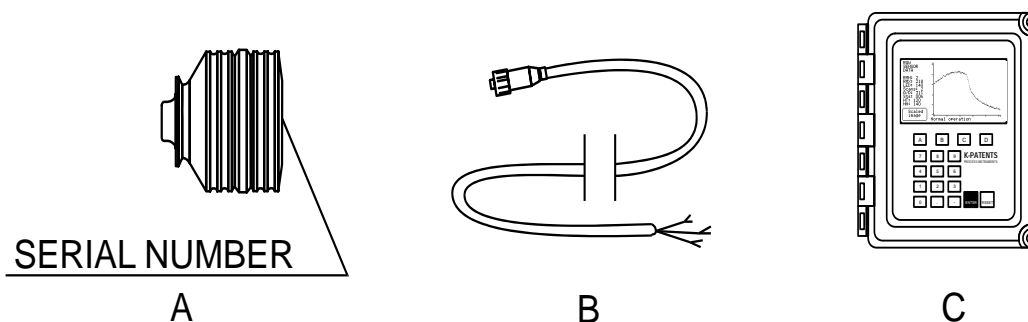

Figure 2.10 Equipment

The K-Patents Sanitary Refractometer provides a 4 to 20 mA DC output signal proportional to process solution concentration. A serial output is also available as a standard.

Identification: By Serial Number (S/N) label (Figure 2.11) on the Indicating Transmitter front panel and by Serial number on sensor label (Figure 2.10, Figure 2.12), e.g. 97A25-1029.

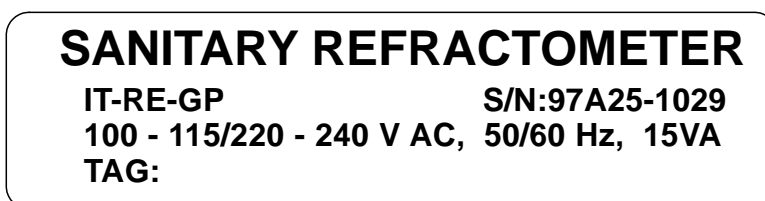

Figure 2.11 Identification label, Indicating Transmitter.

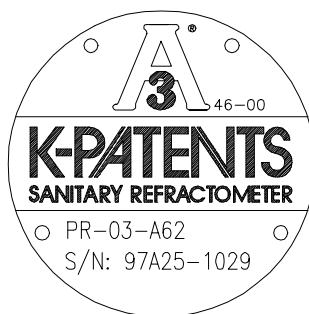

Figure 2.12 Identification label, Sensor.

2.2. STANDARD SPECIFICATIONS

Refractive Index range:	R.I. 1.3100...1.5400 (corresponds to hot water...100 Brix)
Accuracy:	R.I. ± 0.0002 (corresponds typically to $\pm 0.1\%$ by weight). Repeatability and stability correspond to accuracy.
Speed of response:	1.2 s undamped
Damping time constant:	Selectable up to 5 min
Process temperature:	-20°C...130°C (-4°F...266°F)
Temperature compensation:	Automatic
Ambient temperature:	Sensor: max. 45°C (113°F), min. -20°C (-4°F), Indicating transmitter: max. 50°C (122°F), min. 0°C (32°F)
Process pressure:	Sanitary clamp max. 15 bar (200 psi) at 20 °C (70 °F)/ 9 bar (125 psi) at 120 °C (250 °F)
Recommended flow velocity:	Above 1.5 m/s (5 ft/s)
Quality certificate:	ISO 9001

Sensor:	Meets the requirements of the 3-A Sanitary Standard
Wetted parts:	AISI 316L stainless steel, prism gaskets teflon, prism spinel
Sensor weight:	3 kg (7 lbs)
Sensor protection class:	IP67, Nema 4X
Process connection:	2½" Sanitary clamp
Temperature measurement:	Built-in Pt-100
Image detector:	1024 pixel CCD-element
Light source:	Light emitting diode (LED)

Indicating Transmitter:	Enclosure IP66, Nema 4X
Indicating Transmitter weight:	4,5 kg (10 lbs)
Display:	256 x 128 pixels graphic liquid crystal (LCD)
Keypad:	18 membrane keys
Current output	4-20 mA/0-20 mA, max. load 1000 Ohm Galvanic isolation 1500 V DC or AC (peak) Built-in hold function during prism wash.
Serial output:	RS485/RS232, Foundation Fieldbus Galvanic isolation 500 V DC or AC (peak)
Power:	100-115 V/220-240 V, 50/60 Hz, 15 VA
Alarms:	Two built-in signal relays, max 24 V, 500 mA, DC/AC

Interconnecting cable:	Shielded cable, 2 twisted pairs with individual shields, 0.5 mm ² . Digital transmission according to RS485.
Interconnecting cable length:	Standard 10 m (33 ft), max. 100 m (330 ft)
Options:	<ul style="list-style-type: none"> ▶ Cable fittings to the Indicating Transmitter: European cable glands or US conduit hubs, see Section 7.3. – External output unit, Section 10.1 – Relay units for prism wash/alarm, Section 9. – Prism wash nozzles for steam and hot water, Section 8. – Flow cells according to separate drawings available from K-Patents.

Ordering information:

- Desired scale, properties of process solution
 - Process temperature and pressure range
 - Process flow range and pipe diameter
 - Length of interconnecting cable
 - Supply voltage and frequency
 - Options and accessories
 - User tag
- (We reserve right to technical alterations.)

2.2.1. MODEL CODE

Model and Description	Model
PR-03-A = Sensor	PR-03-A
Refractive Index range limits
62= R.I. 1.310....1.540 (0-100 Brix)	62
Process connection
-H = Sanitary 3A-clamp, 2 ½ inch	-H
Sensor wetted parts material
SS = AISI 316 L	SS

Model and Description	Model
IT-R = Indicating Transmitter	IT-R
Cable connection
U = 1/2 inch NPT-type conduit hubs	U
E = BF11/ PG11 Cable glands (with -GP option only)	E
Electrical classification
- GP = General purpose	-GP
- CS = CSA appr.for use in general purpose (ordinary) locations	-CS
Transmitter options
-WR = Wash control relay unit, 2-relays	-WR

Part Number and Description	Part No.
PR-8300 = Interconnecting cable between transmitter and sensor	PR-8300
Cable length
-010 = 10 meters (33 feet), standard length	-010
- _ _ _ = Specify cable length in meters with 10 meters increments. Maximum length is 100 meters (330 feet)	_ _ _

Model and Description	Part No.
EFC = Elbow Flowcell	EFC
Sensor connection
-H = Sanitary 3A-clamp, 2 ½ inch	-H
Material of Construction
SS = AISI 316	SS
Process connection
-H = Sanitary 3A clamp	-H
Pipe section diameter
15 = 40 mm (1 ½ inch)	15
20 = 50 mm (2 inch)	20
25 = 65 mm (2 ½ inch) (with -SI option only)	25
Flowcell inlet type.....
-SI = Straight pipe	-SI
-RI = Reduced pipe (cone)	-RI

Example: PR-03-A62-H-ET-SC
IT-RE-GP-WR-FB
PR-8300-050

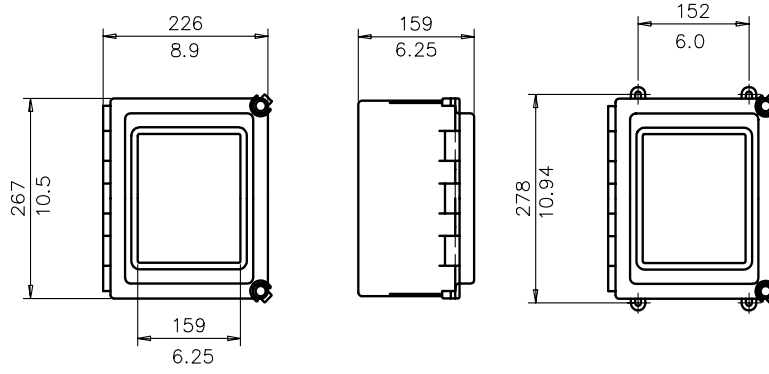

Figure 2.20 Indicating Transmitter: Dimensions (mm/in) and mounting feet measures.

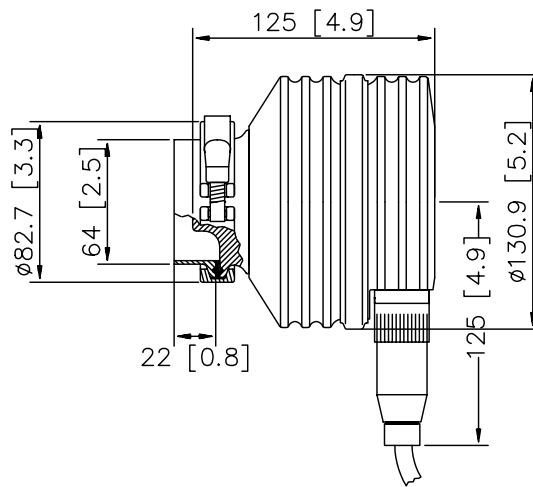

Figure 2.21 Dimensions: Sensor with 2 1/2" Sanitary clamp (mm [in]).

2.3. PRINCIPLE OF MEASUREMENT

The K-Patents Sanitary Refractometer determines the refractive index (R.I) of the process solution by measuring the critical angle of refraction. The light from a light source (L) (Figure 2.30) is directed against the interface between a prism (P) and the process solution (S). Two of the prism surfaces (M) are total-reflecting mirrors bending the light rays. The light rays meet the interface at different angles. The reflected rays form an image (ACB), where (C) is the position of the critical angle ray. The rays at (A) are totally reflected at the process interface, the rays at (B) are partially reflected and partially refracted into the process solution. In this way the optical image is divided into a light area (A) and a dark area (B). The position of the borderline (C) between the areas shows the value of the critical angle and thus of the refractive index of the process solution. The refractive index normally increases with increasing concentration.

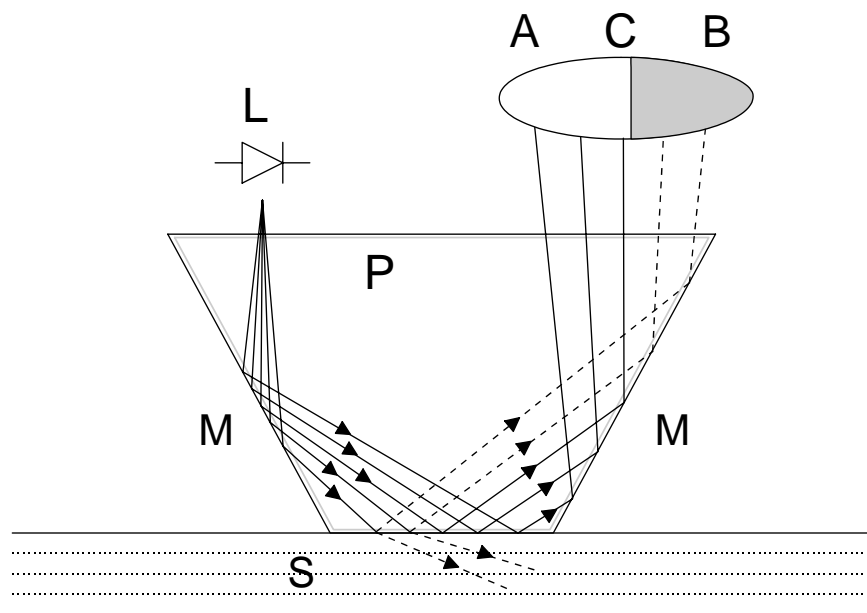

Figure 2.30 Refractometer principle.



Figure 2.31 Optical images.

From this follows that the optical image changes with the process solution concentration as shown in Figure 2.31. The optical image is converted to an electric signal by an image detector.

By this method the concentration of the solution is measured. The colour of the solution, gas bubbles or undissolved particles do not interfere with the result.

2.4. SENSOR DESCRIPTION

In the K-Patents Sanitary Refractometer Sensor (Figure 2.40) the measurement prism (A) is flush mounted to the surface of the probe tip. The prism is fixed to the analyzer module (C) which is springloaded (D) against the prism gasket (B). The light source is a light emitting diode (K). The digital image sensor (G) is a CCD element consisting of 1024 photocells in a row integrated on one chip. The image sensor (G) is protected from the process heat by two isolating parts (H). Excess heat is transferred by a heat conductor (I) to the air cooled sensor cover (J).

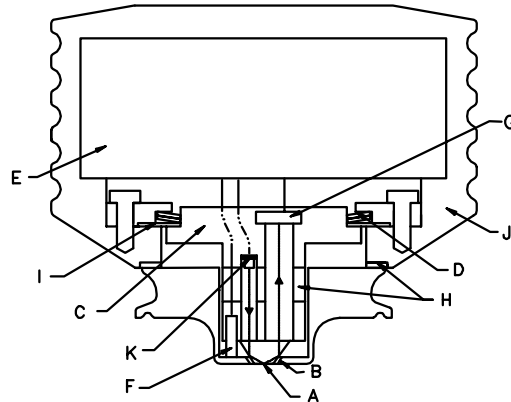

Figure 2.40 Sensor structure.

The image detector output is a pulse train as shown in Figure 2.41. This number of high pulses corresponds to the position of the shadow edge in the optical image. The number of high pulses is a direct measure of the critical angle. The image digitizer (E) transforms this pulse train to a serial digital signal. This serial signal transmits a package containing a complete description of the optical image and temperature data to the Indicating Transmitter.

Note. K-Patents Sanitary Refractometer PR-03 is using a 1024-pixel CCD-element. To keep the supporting computer software compatible for all K-Patents Refractometers, the TEST value (= number of photocells at the light side) is scaled to the range 0-256. That is, for PR-03 the number of high pulses (Figure 2.41) is divided by four.

For automatic temperature compensation, the sensor tip contains a process temperature probe (F), Pt-100. The response time is $\tau(1/2) = 6$ s.

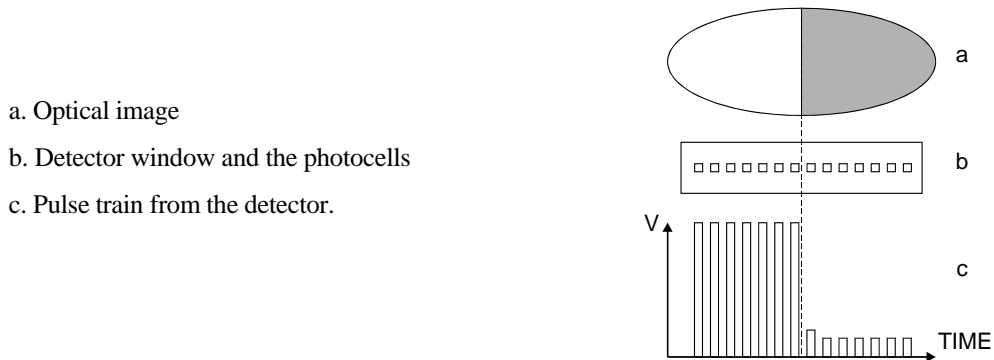

Figure 2.41 Image detector system.

2.5. THE INDICATING TRANSMITTER

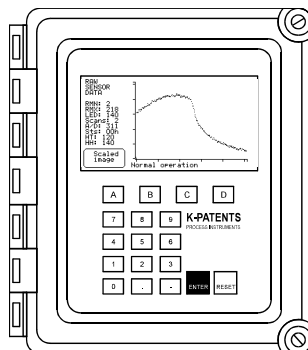

Figure 2.50 The Indicating Transmitter.

The Indicating Transmitter (Figure 2.50) receives a serial signal from the Sensor describing the optical image and also giving the process temperature. The microprocessor system displays the optical image (Figure 2.72) and implements an image analyzing algorithm (Figure 2.52), which identifies the exact position of the shadow edge shown in Figure 2.41.

The Indicating Transmitter contains a power supply, a microprocessor system and a front panel with a Liquid Crystal Display (LCD) and a Keyboard. The output signals are a 4-20 mA concentration signal and a Serial output signal, RS232 or RS485 alternatively.

There are also **two built-in signal relays** (Relay 1 and Relay 2) on the power supply card inside the Indicating Transmitter. These two signal relays can be configured to any relay function (described in Section 9.2), except preconditioning or wash control. Configurations are made from the main calibration menu, see Figure 2.61. Note: the default setting for the built-in signal relay 1 is No Malfunction and for the relay 2 Internal Humidity Above 50%. A closed contact on the relay 1 indicates that the instrument works properly. It is recommended to use this relay for alarm purpose in a control system. For connections, see Figure 3.61.

The Indicating Transmitter also accepts 4 input switch closures for signal HOLD or scale selection. A serial bus connects the Indicating Transmitter to the external units such as Relay Unit (See Section 9) or External Current Unit (Section 10.1).

Unauthorized access can be prevented: Knockout padlock provisions are included in both cover latches. For password protection, see Section 2.11.

The microprocessor system linearizes the concentration reading, like in the example Figure 2.51, and performs an automatic temperature compensation.

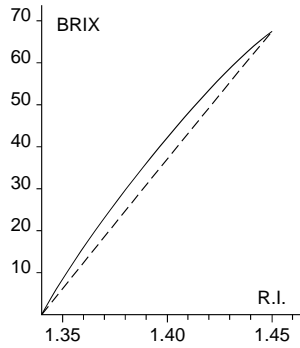

Figure 2.51 BRIX diagram.

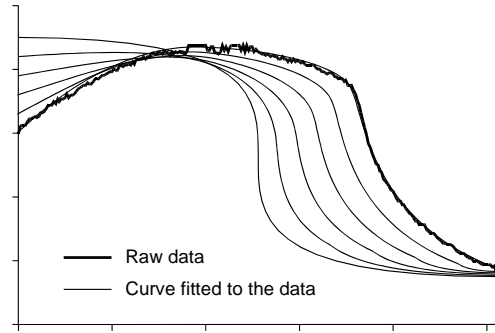

Figure 2.52 Image analyzing algorithm.

2.6. DISPLAY AND KEYBOARD

A built-in Demo program can be used for training, See Section 4.3.

The Normal Display (Figure 2.60) gives the following information:

- Concentration (large size characters) in %, g/l or other units, see Section 2.8.
- Process temperature in °C. Alternatively °F can be displayed, see Section 2.8.
- TEST value: The number of photocells at the light side in the optical image divided by four
- Diagnostic messages like "Normal operation", see Section 6.3.
- Activated alarms
- Soft Keys: The definitions are shown above the corresponding keys A, B, C and D.

For the Normal Display Figure 2.60, pressing key A starts a prism wash cycle when a Relay Unit (Section 9.) is used for prism wash. If a Relay Unit is not used for that purpose, the soft key "Start prism wash" is not visible.

A timeout is set for all displays. The timeout is one hour (60 minutes) for the following displays: Diagnostics Slope, Scaled Image, Raw Sensor Data, Optical Image, Normal Display. The timeout is one minute (60 seconds) for all other displays. During the timeout the display functions the same way as pressed the "Reset" key.

The keys C and D change the Normal Display to a Calibration menu (Figure 2.81) or an Information Display (Figure 2.71) respectively.

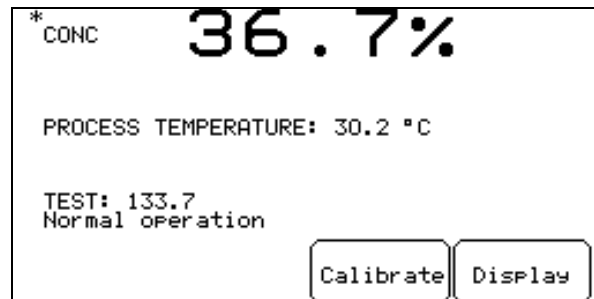

Figure 2.60 Normal Display.

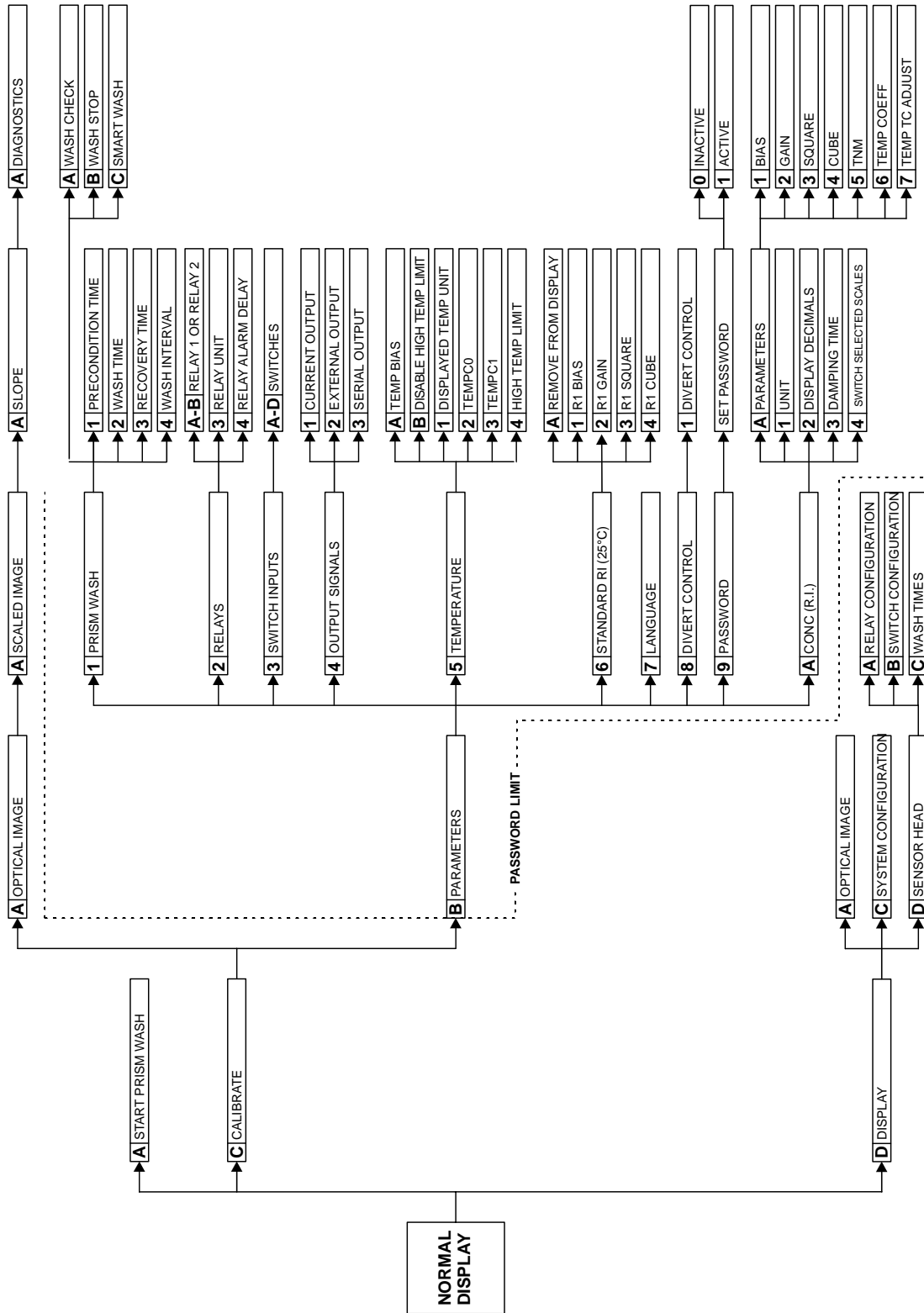

Figure 2.61 The selection tree.

Note! Relay 1 or Relay 2 refer to built-in signal relays, whereas relay unit refers to external relay unit (see Chapter 9).

The selection tree:

The display selections are structured like a tree as shown in Figure 2.61. Using the soft keys (A, B, C, D) it is possible to select the next display. In some cases the selection is made from a menu using a numerical key. In Figure 2.61 the Soft Key selection is indicated by letters A-D, menu selection by numbers 1-9. The display itself provides guidance to find the right path step-by-step, which minimizes the need to consult the manual.

The RESET key is used to move backwards, for each RESET the next display back is selected.

Data entry:

When "New value: _ _ _ _" is displayed, new parameter values can be entered by the numerical keys. Erroneous numbers are erased by RESET. Press ENTER, when the number is complete. After this ENTER, as well as after any change, there appears on the display:

Press ENTER to change
(Otherwise press RESET)

2.7. INFORMATION DISPLAY

The Information Display, Figure 2.71, is selected by the soft key "Display" at the Normal Display (Figure 2.60). This "Display" branch of the selection tree is safe, because here no changes can be made to the system.

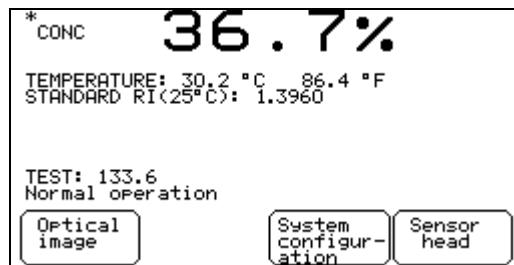

Figure 2.71 The Information Display.

The Information Display contains additional data compared to the Normal Display:

- The PROCESS TEMPERATURE in both °C and °F
- The STANDARD RI (25 °C). This shows the Refractive Index of a standard RI liquid applied to the prism, see Section 5.4.
- output current in mA

Optical image (soft key):

Shows the Optical Image, Figure 2.72. The light area (high pulses) is to the left, the dark area (low pulses) is to the right, compare to Figure 2.41. The vertical scale is 0-100 % of highest pulse amplitude, the horizontal scale expresses the numbers of the photocells 0-1024. The three leftmost pulses represent additional dark reference cells.

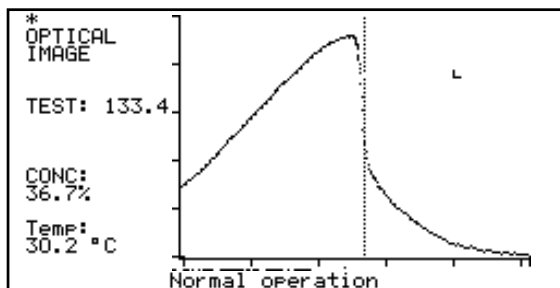

Figure 2.72 The Optical Image.

System configuration (soft key):

- Main program and sensor processor and sensor interface processor versions
- Connection and processor versions of accessory units
- Current output scale: E.g. "4...20 mA = 40.0...60.0 CONC%"
- Two soft keys, **Relay configuration** and **Wash times**. For details see Section 9.2.
- One soft key **Switch configuration**, see Section 2.8.

Sensor head (soft key):

- Head temperature
- Head humidity. For details see Section 6.1.

2.8. CALIBRATE

The soft key "Calibrate" brings forward two alternative soft keys: "Optical image" and "Parameters".

Optical image (soft key):

Displays all raw data from the sensor including the optical image followed by the SCALED IMAGE, SLOPE AND IMAGE DIAGNOSTICS screens, see Section 6.5.

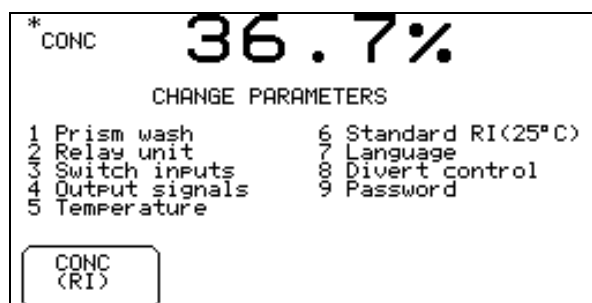

Figure 2.81 Change parameters menu.

Parameters (soft key):

Displays the CHANGE PARAMETERS menu (Figure 2.81) which contains:

CONC (RI) (soft key):

Further by the soft key "Parameters", the calibration parameters for the concentration are entered, see Section 5.2.

Menu selected functions are:

1. Concentration unit, can be "CONC %", "CONC g/l", "CONC", "OECHSLE" or "BRIX". Also available is the unit RI (x °C), which is "RI measured in the laboratory at x °C" where typically x = 60 °C, displayed as RI (60 °C). The unit RI (x °C) should not be confused with "Standard RI (25 °C)" even if the x can be chosen as 25.
2. Number of CONC display decimals.
3. Damping time in seconds. This is the time it takes for the concentration measurement to reach half of its final value at a step change of the concentration
4. Switch selected scales. Provides four additional complete sets of calibration parameters, see "Switch inputs" below.

1. Prism wash:

Entering of prism wash times for the Relay Unit and a wash check and wash stop functions, see Section 9.2.

2. Relays:

Provides relay configuration, see Sections 2.5 and 9.2.

3. Switch inputs:

The microprocessor accepts four switch inputs (A, B, C and D), for connections see Figure 3.64. The function of each switch can be individually defined from one of four alternatives

0. Not defined (which is the factory setting).
1. Remote wash start for Relay Unit wash function and external Hold. The external Hold is used with a wash timer other than the Relay Unit, or to hold the signal during stops in an intermittent flow (e.g. by contact from the pump control). A wash start is also initiated when the contact opens, if it has been closed longer than one minute.
2. Defined to select alternative process mediums. There are all together four alternative mediums selectable by closure of the corresponding switch. If no selection switch is closed, the normal medium is selected. Maximum number of mediums is five (Normal, A, B, C, D).
Note. The range will not change. Example: medium 1 = 20 - 40 % Sugar, medium 2 = 20 - 40 % Salt.
3. External wash stop: An input switch can be configured to an external wash stop to prevent the prism wash when the corresponding input switch is connected. "External wash stop"-message will show when automatic wash is activated. The input switch can be set to protect the refractometer e.g. if the process is stopped.
4. Calibration stop: An input switch can be configured for calibration stop. Activating and connecting the input switch will prevent calibration through software.

4. Output signals menu:

1. Current output. Sets the zero and span in concentration units that correspond to 4-20 mA output. The signal range 0-20 mA can also be selected. The 0 will be slightly above 0 mA, typically 0,06 mA. An active HOLD function locks the signal during prism wash by the Relay Unit. When the HOLD function is inactive, the wash results can be seen as a negative peak in the output signal.
2. External current output. Defines the scale for the External Output Unit (Section 10.1) the same way as above. In addition the source has to be selected from the list Concentration/Standard RI (25 °C)/Temp °C/Temp °F.
3. Serial output. The format is to be defined, see Section 3.7.

5. Temperature menu:

The temperature calibration is made through this menu, see Section 5.8. It is also possible to select the temperature display unit in the normal display as °C/°F. A high temperature limit can be activated and set for a "High process temperature" message, Section 6.3.

6. Standard RI (25 °C):

Gives the calibration parameters for the bench calibration value with standard RI liquids, Section 5.4. The RI (25 °C) can also be added to the normal display.

7. Language

Selection of display language: 1. English 2. German.

8. Divert control

Not in use for K-Patents Sanitary Refractometer PR-03. Must be deactivated.

9. Password

A software password can be selected to prohibit unauthorized calibration, see Section 2.11.

2.9. COMPATIBILITY WITH K-PATENTS PROCESS REFRACTOMETER PR-01

Sensor

The K-Patents Process Refractometer PR-01 with a Sanitary clamp connection uses a 4" 3A clamp, which is larger than the 2½" clamp used by K-Patents Sanitary Refractometer PR-03.

Interconnecting cable

The plug at the sensor end is different for PR-03 and PR-01.

Indicating Transmitter

The models PR-03 and PR-01 use the same Indicating Transmitter IT-R. When the power is switched on, the microprocessor checks which model is connected, and adapts the software accordingly.

2.10. PROGRAM VERSIONS

The program version number consists of two digits. The first digit is the major version, the latter is the minor version. Programs with the same major versions are compatible. Also earlier major versions can usually be substituted with later major versions.

Before you upgrade any program versions, write down all current parameters from the calibration screen of the Indicating Transmitter. Then insert the new program version. Choose the "Default parameter load" at start and enter the old parameters in.

2.11. PASSWORD

The "CHANGE PARAMETERS" screen can be optionally locked behind a password function. When the password function is activated, entry to this screen is not allowed without a correct password, see Figure 2.61.

The password function can be activated or inactivated by selecting: "Calibrate/Parameters/9.Password/0. Inactive or 1. Active".

The password for K-Patents PR-03 is printed on the front page of this manual.

2.12. WARRANTY

K-Patents warrants that all products made by K-Patents shall be free of defects in material and workmanship. K-Patents agrees to either replace or repair free of charge, any such product or part thereof which shall be returned to the nearest authorized K-Patents repair facility within two (2) years from the date of delivery.

3. MOUNTING

3.1. SENSOR LOCATION

The recommended mounting is in a pipe bend, with a vertical flow upwards before the sensor, and a horizontal pipe after, see mounting recommendation Figure 3.10. By this mounting is obtained

1. Selfcleaning of prism due to the flow directed against its surface.
2. Efficient drainage when the pipe is emptied.

The cable connector socket of the sensor should be directed downwards.

The sensor is designed to be installed directly in a process line. If the sensor is located outdoors, some basic protection against direct exposure to sunlight and rain should be provided. Special care should be taken, if the pipe wall is translucent (e.g. of glassfiber), because light from outside reaching the prism will disturb the measurement.

Air-cooling

Normally, draught and natural convection provide sufficient air cooling. There must be no obstacles to air flow around the sensor head. The red sensor cover should not be exposed to high temperature radiation.

If the ambient temperature is higher than 45°C (113°F) the air-cooling should be improved by blowing pressurized air against the red sensor cover. This is also recommended when the process temperature is above 110°C (230°F) when the ambient temperature is above 35°C (95°F).

The pressurised air can be supplied by the ventilation system. If no air is available it is possible to wind a copper coil for cooling water around the sensor head cover.

Process flow conditions

The sensor is designed to make the prism self-cleaning. To ensure a representative sample and also prism cleaning action, a good process flow should be directed against the prism surface. A flow velocity above 1.5 m/s (5 ft/s) is recommended. For lower velocities prism wash (Section 8) should be considered. Flow velocity is calculated from $v[\text{m/s}] = 21.2 * \text{Flow}[\text{lit}/\text{min}]/d^2[\text{mm}]$; $v[\text{m/s}] = 0.125 * \text{Flow}[\text{Gpm}]/d^2[\text{in}]$.

Accumulation of sediment or of gas bubbles should be prevented.

If the process pipe vibrates, support the pipe.

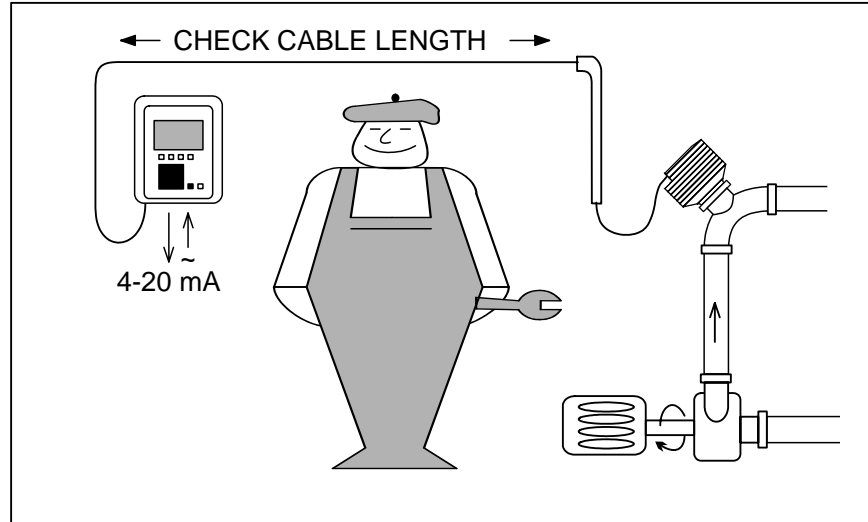

Figure 3.10 Mounting recommendations.

Selection of location

To decide "Where to mount" use the following criteria:

1. Process pipe is preferred to process vessel, because favorable flow conditions are difficult to ensure in a vessel.
2. If the process pipe diameter varies, select the position with the smallest diameter (and accordingly highest velocity). Then the prism keeps better clean. If the pipe is coned up after a pump, valve or magnetic flow meter, then add a length of straight pipe before the coning up and mount the refractometer there.
3. If the refractometer is used in a feed-back control loop, make the time lag small. E.g. when a dilution valve is controlled, mount the refractometer as near the dilution point as possible.
4. If the temperature varies along the process pipe, select the position with the highest temperature. Then the risk of prism coating is minimized, because higher temperature means higher solubility and also lower viscosity.
5. Often the position with the highest pressure (= after pump + before valve) has favourable flow conditions without sedimentation or air trapping risks.
6. The sensor should be conveniently accessible.

3.2. MOUNTING EXAMPLES

K-Patents Sanitary Refractometer PR-03 is connected to the process by a 2½" 3A Sanitary clamp, Figure 3.20 and Figure 3.21.

For pipe diameters of 3" or above, a ferrule is welded directly to the pipe wall. (A ferrule, length 21.5 mm, can be ordered from K-Patents). Flow cells for smaller pipe diameters are available from K-Patents. The inlet of the flow cells is coned down to obtain a good flow velocity against the prism. The flow cells are exchangeable with standard 90° bend pieces.

Pipe diameter 3" (80 mm) or larger

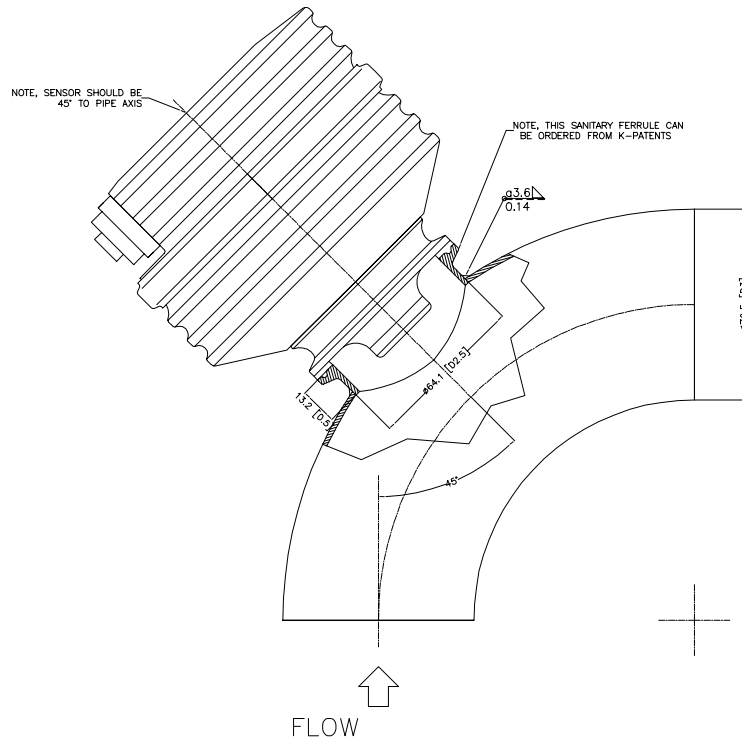

Flow cell:
Pipe diameter 2½" (65 mm)

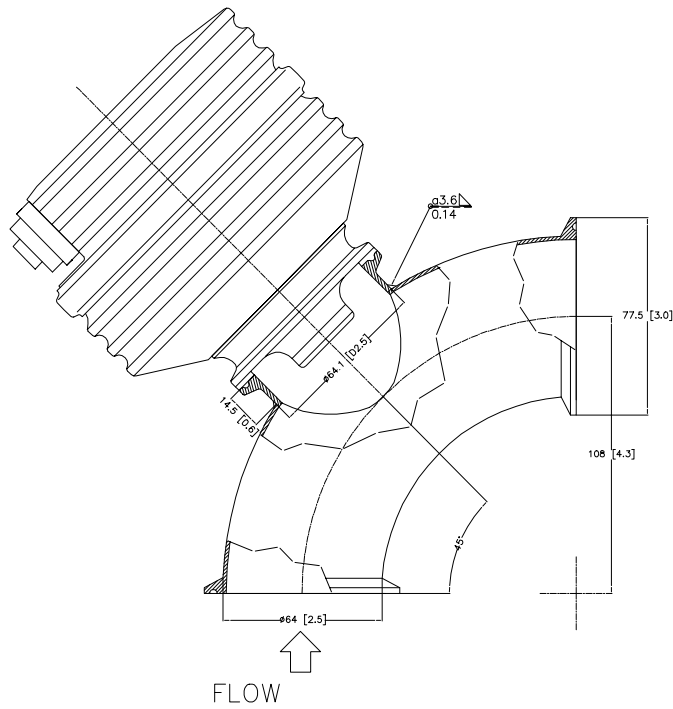
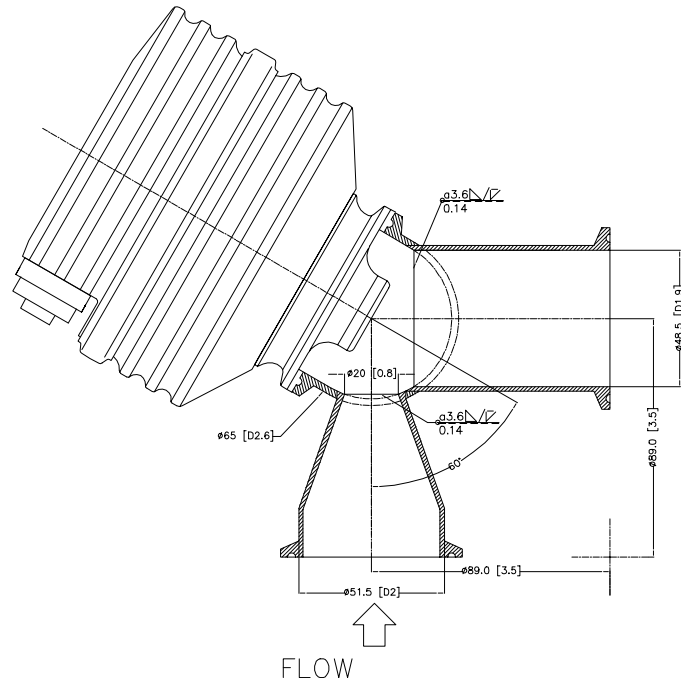

Figure 3.20 Sanitary clamp mounting (mm [in]).

Flow cell:
Pipe diameter 2" (50 mm)



Flow cell:
Pipe diameter 1½" (40 mm)

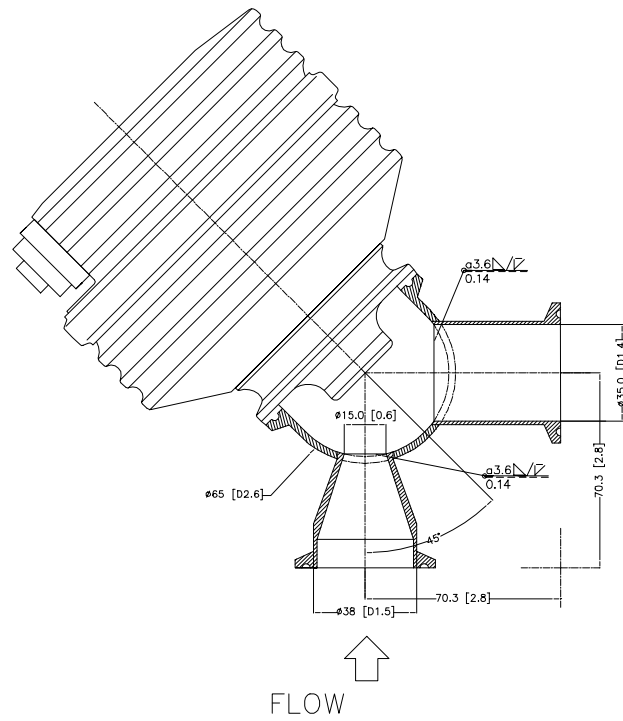

Figure 3.21 Sanitary clamp mounting (mm [in]).

3.3. MOUNTING OF SENSOR

Remove the prism protection sticker before the sensor is connected to the process line.

Identify the sensor by the serial number. Check that it matches the serial number of the Indicating Transmitter.

Turn the sensor so that the cable plug socket points downwards.

After connecting the cable, join the two connector protecting caps to keep them clean inside.

3.4. WASH NOZZLES

For mounting of the prism wash systems, see Section 8.

3.5. INDICATING TRANSMITTER

The Indicating Transmitter should preferably be located in an easily accessible, well lighted and dry area. The enclosure must not be exposed to rain or direct sunlight. Avoid vibration. Take interconnecting cable length into consideration.

The enclosure is mounted on a wall using four mounting feet, Figure 2.20. **Do not drill mounting holes in the enclosure.**

Note: The LCD display has an operating temperature range of 0...50°C and a storage temperature range of -20...60°C.

Check the serial number from the label, Figure 2.11.

An Indicating Transmitter can be exchanged for another of the same model, but the current calibration constants have then to be entered by the keyboard (Section 5.7). For compatibility information, see Section 2.9.

3.6. ELECTRICAL CONNECTIONS

The electric terminals of the Indicating Transmitters are all on the Power Supply card, Figure 6.40. This is accessible by opening the enclosure and the front panel. The front panel swings out after the two screws to the right have been loosened (Section 7, Parts list, Indicating Transmitter, item 3.14).

Power:

The power is specified in the DELIVERY DATA SHEET and on the Label (Figure 2.11). The position of the power select switch on the Power Supply card (Figure 6.40, SW2) should also be checked. The power select switch has two positions: 220-240 V/50-60 Hz or 100-115 V/50-60 Hz.

The primary AC power is connected to a separate terminal strip 39/40/41 on the Power Supply card marked POWER (Figure 6.40): The terminals are marked 39/L, 40/N and 41/ground symbol.

The power terminals L and N are directly connected to the transformer primary loop, and galvanically separated from the rest of the instrument. The ground terminal (41) is connected to the bottom plate of the Indicating Transmitter, to the transformer shield winding and to the outer shield of the interconnecting cable.

Terminal strip:

The rest of the connections are made to the terminal strip, Figure 3.61.

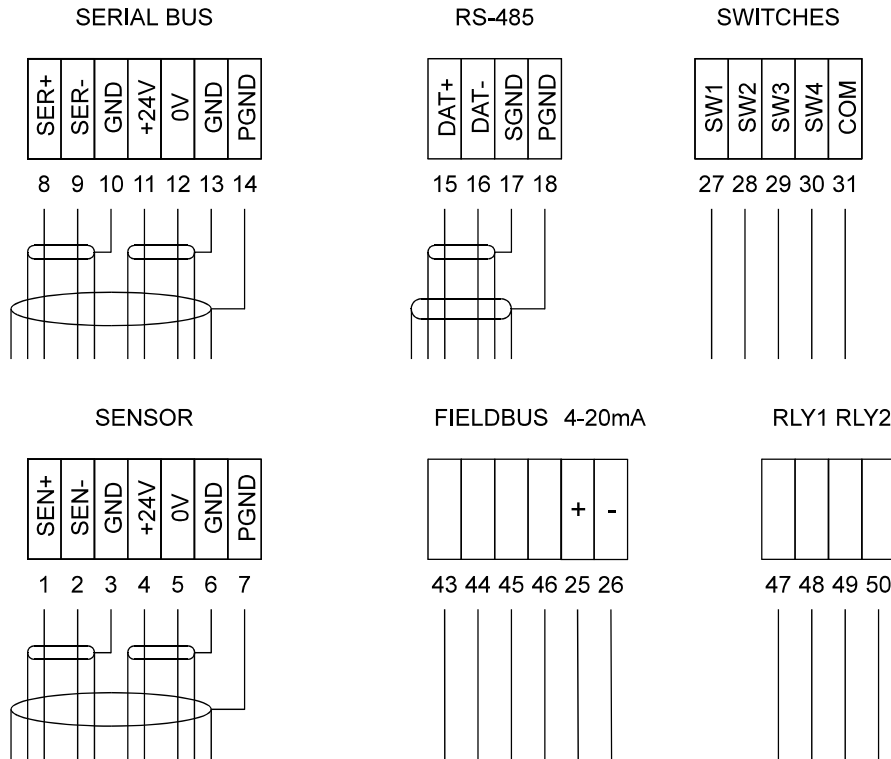

Figure 3.61 Terminal strip.

Sensor:

The Indicating Transmitter end of the interconnecting cable has leads numbered from 1 to 7 to be connected to the terminals with the same numbers. The sensor end of the interconnecting cable is terminated by a plug, Figure 6.22. The interconnecting cable may be shortened or lengthened up to the limit specified, Section 2.2. The interconnecting cable should be installed in a separate metal conduit. For cable specifications, see Section 2.2.

Current output:

The terminal 25 is plus (+) and 26 minus (-) for the 4-20 mA output signal. The signal is specified in Section 2.2.

Recorders, controllers, indicators etc. shall be connected to form a closed current loop, starting from terminal 25 passing each device, in at plus and out at minus, ending at terminal 26. Be careful not to exceed the specified load resistance.

The range of the output signal can be set to 0-20 mA from the keyboard (Section 2.8), select Calibrate/Output signals/Current output/Range.

Serial output RS-232/RS-485:

Terminals 15-18 and Plug connector P3, see Serial output Section 3.7.

Serial bus:

Terminals 8-14 provide connection to K-Patents accessory units, like the Relay unit (Section 9) and External Output Unit (Section 10.1). The same type of cable is used as for the interconnecting cable to the sensor specified in Section 2.2.

The terminals 8-14 are connected to the same numbers in the external units. Connect the external units in a chain beginning from the Indicating Transmitter and ending at the Relay unit (Figure 3.63). For an intermediate unit (e.g. External output unit), the Serial bus input is terminals 8-14 /A and output 8-14/B. If there is no Relay Unit to complete the chain, connect a 120 Ohm resistor over the terminals 8/B and 9/B at the last unit.

Note: The current loop of the Serial bus must always be closed, by a Relay Unit or the 120 Ohm resistor.

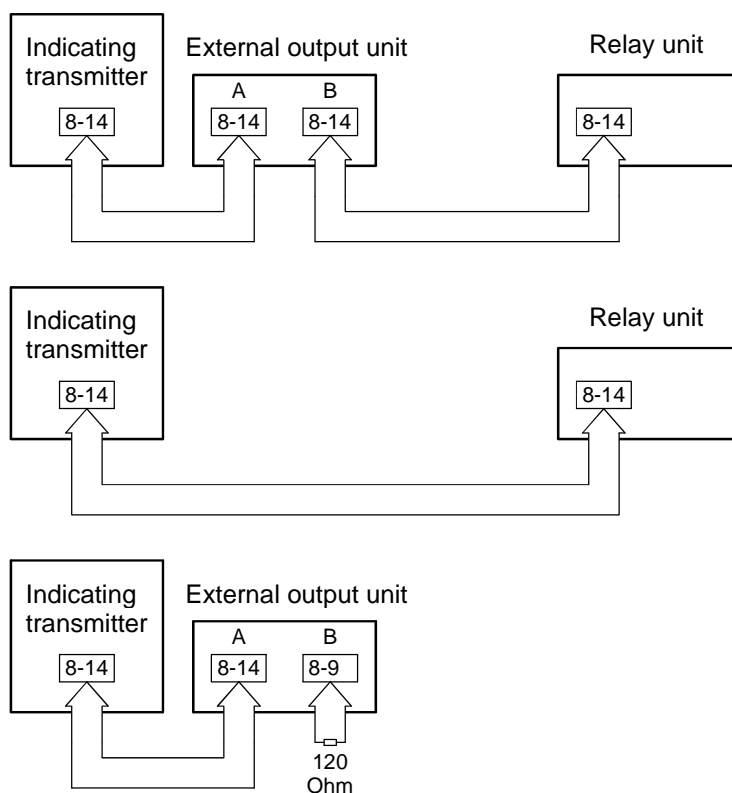

Figure 3.63 Serial bus connections.

Input switches:

Altogether four input switches A, B, C and D (Figure 3.64) can be connected: Terminals 27-A, 28-B, 29-C, 30-D, 31-Common. The switches may be separate, or together in one rotary switch. Input switches can be configured through software, Section 2.8.

A 5V voltage is provided over each switch. The switch terminals are all galvanically isolated from ground and from the rest of the electronics.

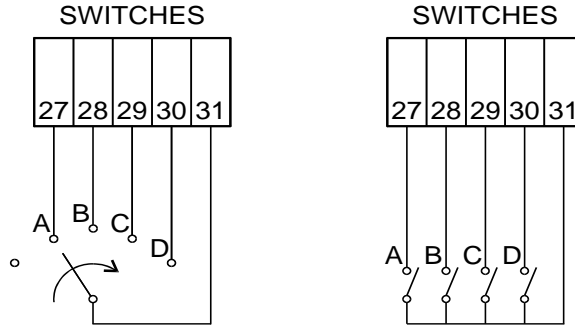

Figure 3.64 Connections to input switches.

3.7. SERIAL OUTPUT

A remote display unit, a computer, or a terminal can be connected to the Indicating Transmitter serial output terminals. In the Indicating Transmitter either RS-232 or RS-485 interface may be used.

The output measurement results are sent in ASCII code (**ISO 646, CCITT V.3**) using a standard asynchronous interface. The output consists of fixed-length text records. A record is sent for every measurement interval (1200 ms).

RS-232: Conforms to the EIA RS-232-C and CCITT V.24 standards. The signals are available at plug terminal P3. Cable diagrams are shown in figure 3.70 (for modems) and figure 3.71 (for computers). Both 25-pin and 9-pin D-shell connector pin numbers are given. If the ITR is to be connected to a computer, connections 4-5 and 6-8-20 (see figure 3.70) may be omitted in most cases. **Note:** RS-232-C specifies a maximum cable length of 15 m.

RS-485: The physical interface conforms to the EIA RS-485. The cable should be a shielded twisted pair. The RS-485 signals are available at P3 (DAT- and DAT+ in figure 3.70) or strip terminals 15-18. For a shielded cable connection (recommended), see figure 3.61. K-Patents recommends a cable length not exceeding 200 m.

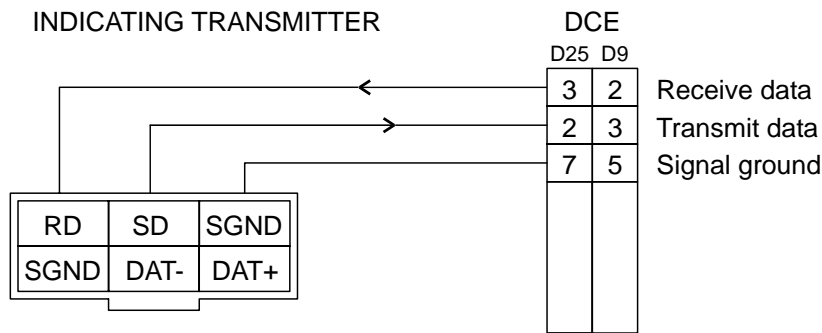

Figure 3.70 RS-232 connection to DCE-type equipment (e.g., modem).

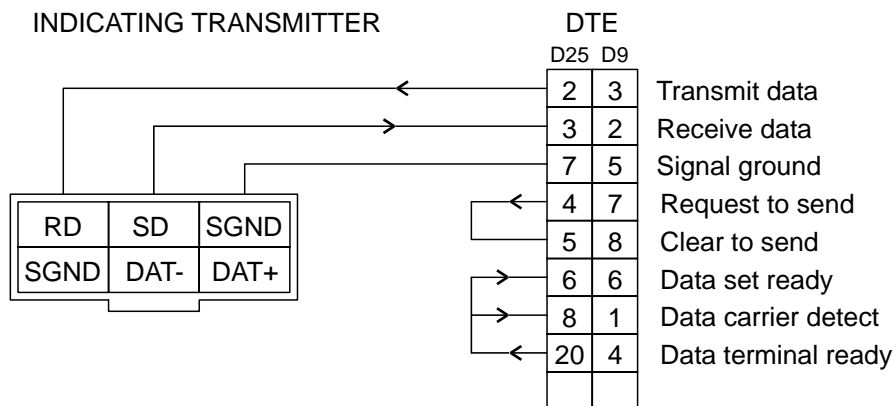

Figure 3.71 RS-232 connection to DTE-type equipment (e.g., computer).

The character structure conforms to the **ISO 1177** standard. It is compatible with the 'RS-232' interfaces of personal computers.

The character parameters are configuration selectable:

- speed** 1200 to 9600 bits/s
- parity** odd, even or none
- stop bits** 1 or 2
- flow control** hardware, XON / XOFF or none.

The set of measurement results is output in a fixed-length record. The record consists of variable-length numeric fields at fixed locations in the record. The gaps are filled with ASCII spaces (code 20 hex).

The record format is:

Column	Field	Format	Value
1	TEST	float, 1 decimal	raw refraction value
16	CONC%	float, selected decimals	concentration value
31	temp C	float, 1 decimal	temperature, degrees centigrade
46	RI 25 C	float, 4 decimals	standard RI at 25 C
61	phase	1 digit	operation phase code
63	error	integer	error code
66	divert	integer	divert control status code
68	checksum	integer	
76	terminator	CR and LF	

If a float value is too large for its field it is output in raw decimal floating point format: +1234567+12. The first sign is the sign of the value. The 7 digit field is the mantissa value after the decimal point. The second sign is the exponent sign. The 2 digit field is the decimal exponent. The example value +1234567+12 is to be interpreted as 0.1234567E12, ie. 123456700000.

TEST: The raw refraction value is the same as in the TEST display. The value is displayed with 1 decimal. The range is 8.0 - 248.0.

Concentration: The concentration value is the same as in the CONC% display. The number of decimals is controlled by the display decimal parameter in EEPROM. The range is dependent of the concentration factors in EEPROM. The value is damped. It is held during wash, hold or recovery phases.

Temperature: The temperature value is the same as in the °C display. The value is displayed with 1 decimal.

Operation phase codes are:

Code	Phase codes
0	Blank
1	Wait
2	Precondition
3	Precondition
4	Wash
5	Recovery
6	Hold

Error status codes are:

Code	Priority	Error status
0	0	No errors
		Process disturbances:
1	1	Retrying wash
2	4	Solids warning
3	5	Solids alarm
4	7	Low concentration / no sample
5	13	Prism wash failure
		Malfunctions:
6	8	High process temperature
7	11	High conc / prism coated
		Instrument malfunctions:
8	14	External output fault
9	15	Relay unit fault
10	16	Divert control fault
11	17	Temperature measurement fault
12	18	Prism coated / LED fault
13	19	Not in line
14	20	Detector timeout
15	21	Sensor transmission error
16	22	No sensor signal
17	23	Wrong concentration parameters
18	24	Constants error
19	25	Sensor interface fault
20	26	EEPROM fault
		Process disturbances
21	9	Low light intensity
22	10	Dip in image
23	6	Wash stop / Temp. limit
24	2	High internal humidity
25	3	High internal temperature
		Instrument malfunctions:
26	12	Wash stop / ext. stop

Checksum: The checksum is the arithmetic sum of ASCII codes in columns before the checksum field. The range is columns 1 to 67. Least significant 7 bits are taken into the sum: the parity bits are zeroed.

Record terminator: The record is terminated with ASCII characters CR (0d hex) and LF (0a hex) to make the record a text line.

3.8. FUSES

Fuses printed on circuit board PR-7030:

Fuse F1, F2: 5 x 20 mm, T1A (slow)	AC Main power protects electronics against wrong primary voltage
Fuse F3: 5 x 20 mm, T63 mA (slow)	4-20 mA output protection
Fuse F4: 5 x 20 mm, T2A (slow)	Secondary main fuse
Fuse F5: 5 x 20 mm, T500 mA (slow)	Sensor power protection
Fuse F6: 5 x 20 mm, T500 mA (slow)	Serial bus protection
Fuse F7: 5 x 20 mm, T1A (slow)	Processor card protection

Note. For a CSA-Certified instrument use only CSA-Certified fuses F1, F2, F4-F7.

4. START UP

4.1. INITIAL CHECK

- a. Check that the Serial Numbers of the Sensor and the Indicating Transmitter match (Section 2.1).
- b. Check wiring and supply voltage (Section 3.6).
- c. Press the main power switch to ON position. The three green LEDs (LD1, LD2, LD3) on the Power Supply card (Figure 6.40) are then turned on.
- d. The display will first show which sensor the microprocessor has identified, PR-01 or PR-03. Then the Normal display (Figure 2.60) will appear. The diagnostic message should be "Normal operation" or if the process pipe is empty "Low concentration/no sample". For any other message consult section 6.3.
- e. The display should show the current process temperature.
- f. TEST value in the display should be in the range 8-248. A value near 248 indicates a clean prism in an empty process pipe.
- g. For the concentration reading, see Section 4.2.
- h. Press soft key "Display" for additional data (Figure 2.71), like e.g. output in mA. Further data is obtained by soft keys "System configuration" and "Optical image ". Figures 4.10 and 4.11 show typical optical images for K-Patents Sanitary Refractometer PR-03. Return to previous display by RESET key.
- i. Measure the output signal. It should agree with the mA display.
- j. **IMPORTANT:** If a prism wash controlled by a Relay Unit is employed, press soft key "Start prism wash" and check the wash sequence. The TEST value should clearly increase (and the concentration reading decrease) during wash. The "Start prism wash" soft key does not show, if no relay is specified as wash relay.

If the initial check is not OK, turn to Section 6.

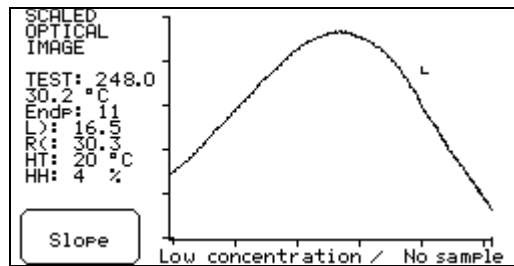

Figure 4.10 Typical optical image for PR-03 when the pipe is empty.

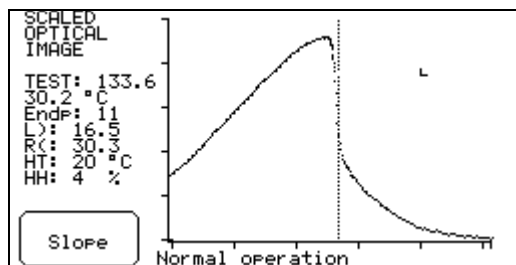

Figure 4.11 Typical optical image for PR-03 during the normal measurement.

4.2. CALIBRATION CHECK

Wait until normal process conditions occur. The instrument is precalibrated at delivery (DELIVERY DATA SHEET). Hence an on-scale output should be obtained. If not, take a few samples and check that the process conditions are normal.

If the diagnostic message is "Normal operation" but the concentration reading is at the wrong level, correction can be entered by the keyboard (Section 5.2).

If the concentration reading is correct, but not the output mA, see Section 5.1.

The damping of the concentration measurement may be increased, e.g. if necessary to get a smoother recorder track, see Section 2.8. A damping time of 15 seconds is normally the best. **WARNING:** Avoid overdamping, the signal should not be insensitive.

4.3. DEMO MODE

The Indicating Transmitter can be used as stand-alone for training of keyboard handling. The built-in Demo program contains a sensor simulator.

To activate the Demo mode

- a. Disconnect the sensor cable (1-7) and all connections to the Serial bus (8-14) from the Indicating Transmitter.
- b. Connect terminal 1 to 8, and terminal 2 to 9, Figure 4.30.

When the Demo mode is active, a small star appears in the top left corner of the display.

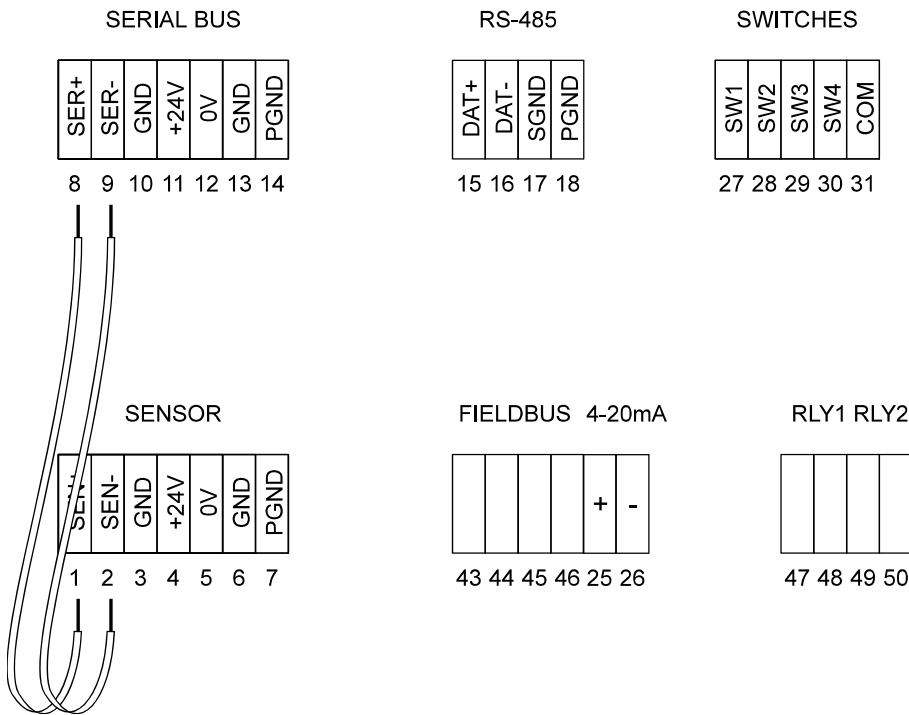

Figure 4.30 Demo connection.

5. CALIBRATION

K-Patents Sanitary Refractometer is delivered precalibrated according to the DELIVERY DATA SHEET. Adjustments or change of range are made by keyboard entry (Sections 5.1 and 5.2). For sensor rangeability, see Section 5.6.

Field calibration

The final calibration to obtain full accuracy is made by sending data to K-Patents or local K-Patents representative for calculations (Section 5.3.).

Temperature calibration is explained in Section 5.8.

5.1. OUTPUT CURRENT RANGE SELECTION

It is possible to change the concentration range of the output current, also when the instrument is installed and operating.

Example: To change 4-20 mA = 15 - 25 CONC% to 4-20 mA = 10 - 30 CONC%, key in the sequence Calibrate/Parameters/Output signals/Current output and then enter Zero = 10 and Span = 20.

5.2. CONCENTRATION CALIBRATION FROM KEYBOARD

The concentration display should be in agreement with laboratory determinations. Deviations can be corrected from keyboard if the diagnostic message is Normal operation.

Off-set adjustment:

A change of the calibration constant Bias influences the CONC% reading the same amount. Key in Calibrate/Parameters/CONC (RI)/Parameters/Bias to read and change the Bias.

Example: If the CONC% display is 26% and the laboratory determination is LAB% = 28%, then a value Bias = 23.456 should be changed to Bias + LAB% - CONC% = 25.456.

Note: The CONC% reading is restricted to positive values even if the mathematical calculation gives a negative value. For a negative CONC% the display shows "0.0". For BIAS adjustment it is useful to know the real CONC% value. For this reason the calculated negative CONC% reading is shown in the Calibration branch of the Selection tree, Figure 2.61.

Warning: Never try to change Bias in a day-to-day manner, or week-to-week. Frequent bias changes will increase the measurement variation, not decrease it.

Amplification adjustment. The size of CONC% changes are directly proportional to the calibration constant Gain. The point, where TEST = 128, is not influenced by Gain. From two measurement points the new Gain can be estimated by the formula $\text{Gain} * (\text{LAB\% 1} - \text{LAB\% 2}) / (\text{CONC\% 1} - \text{CONC\% 2})$. After the change of the Gain, the Bias has to be determined by a new sample.

The constants Square and Cube are linearity corrections that can be provided by K-Patents, see Section 5.3.

5.3. FIELD CALIBRATION

The most accurate calibration is made under normal process conditions employing the users standard laboratory determinations of sample concentration. K-Patents provides a FIELD CALIBRATION service to optimize calibration constants based on data supplied by the user.

The user should systematically record calibrating data by the CALIBRATION DATA REPORT (last page in this manual). Each data point consists of:

LAB% Sample concentration determined by the user.

From refractometer display (Section 2.7):

CONC% Measurement in concentration units

TEST Number of photocells (divided by 4 in model PR-03) on the light side of the optical image (= primary measurement)

TEMP Process temperature measurement in centigrades

Note: A data point is of use for calibration only when the diagnostic message is Normal operation. Do not take samples during the prism wash. A data point is useful even if the concentration value is outside the range of the output current.

To achieve an accurate calibration the sample has to be taken correctly:

- The sampling valve and the refractometer should be installed in the same place in the process.
- Take the sample and read the display at exactly the same time!
- For hot samples use a tight container (avoid evaporation)
- Run the sample before starting to collect (avoid old sample that has remained in the sampling valve).

A completed CALIBRATION DATA REPORT with 5 - 15 calibration points covering the measurement range can be sent to K-Patents or local K-Patents representative by fax. A computer analyses of the data will be made at K-Patents and an optimal calibration data will be faxed to the user.

5.4. BENCH CALIBRATION

The calibration can be checked off-line using Standard RI liquids.

The check should be done at room temperature, but the temperature does not have to be exactly 25 °C as the displayed value is temperature compensated. If the sensor is hot, let it cool down to ambient temperature.

Standard RI (25 °C) Display: Show the standard refractive index value referred to 25°C. For exact calibration, please contact K-Patents or your local K-Patents representative. Calibration parameters are changed by pressing Calibrate/Parameters/Standard RI (25°C) from Normal Display. For RI gain = 0, the indication is 0.0000. For off-set adjustment (like in Section 5.1), the bias change has to be multiplied by 100. E.g. If indication is 0.0004 low, add 0.04 to the bias for RI (25 °C).

Standard RI liquids are available from: R.P. Cargille Laboratories, Inc., 55 Commerce Road, Cedar Grove, New Jersey 07009-1289, U.S.A. Phone: 210-239-6633, Fax: 201-239-6096.

A 12 bottles set of RI liquids is also available at K-Patents with part number PR-2000. The complete set with 24 bottles of liquids covers the RI range 1.300 - 1.530 as follows:

1.300 - 1.390 Cat. No. 18032 AAA-1/2 Half Set, Int. 0,01	10 liquids
1.400 - 1.450 Cat. No. 18065 AA-1/5 Fifth Set, Int. 0,01	6 liquids
1.460 - 1.530 Cat. No. 1809X (in steps of 0,01) A-x Std 1/4 fl.oz. (7cc)	8 liquids

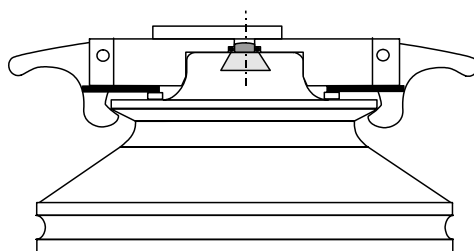

Figure 5.40 Sample holder.

Use a sample holder, Figure 5.40. Then just a few drops of sample are enough. The sample must be covered to prevent outside light to reach the prism. Sample leakage from holder may give measurement error. Always use repeated measurements for each sample. Sample holders are available at K-Patents (Part number PR-1010).

Dispose of used RI-liquids. Do not put liquids back into the bottle after use!

Off-line calibration using **process liquid** seldom gives reliable results, problems are caused by

- low flow which makes sample to form an unrepresentative film on the prism
- sample evaporation at high temperature or undissolved solids at low temperature giving deviations from laboratory determinations
- an ageing sample which is not representative
- outside light reaches the prism

Calibration using the process liquid should be made in-line, see Field calibration (Section 5.3).

5.5. MECHANICAL ZERO ADJUSTMENT

The model PR-03 needs no mechanical adjustments. Calibration is made using the keyboard.

5.6. SENSOR RANGEABILITY

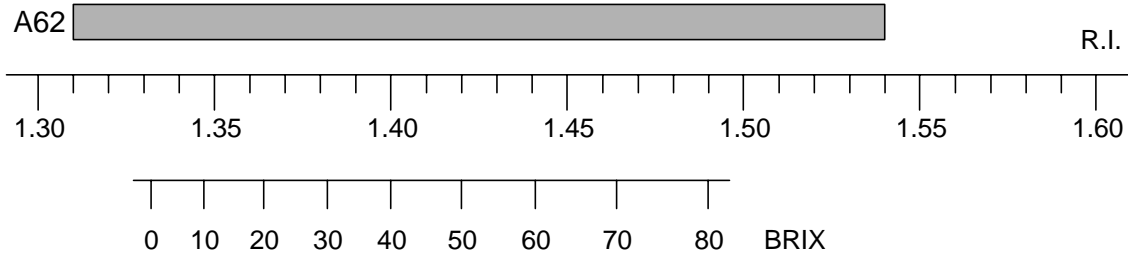

Figure 5.60 Sensor rangeability.

5.7. EEPROM PARAMETERS

How to enter the calibration parameters into the non-volatile EEPROM memory is described in Section 2.8. The factory settings are found in the DELIVERY DATA SHEET. Figure 5.70 shows how the microprocessor program is using the parameters.

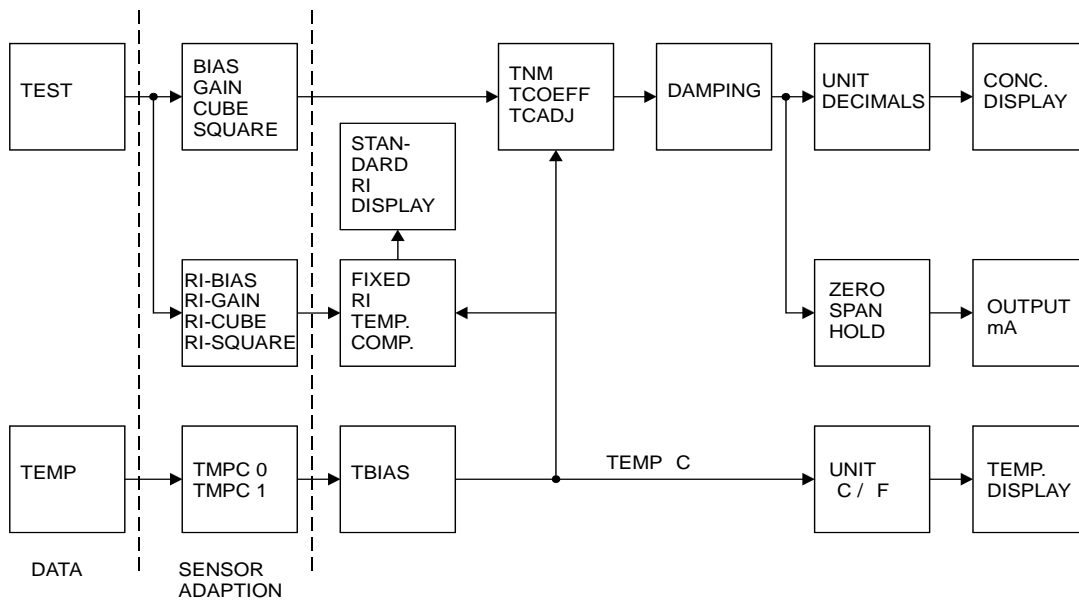

Figure 5.70 Calculation flow diagram.

The ENTER procedure contains a check of the EEPROM parameters format. A number outside the range limits cannot be entered. Only if the range limits of a parameter contain a decimal point, the parameter may contain a decimal point. For some parameters the number of characters is limited (character = digit, decimal point or minus sign).

Indicating Transmitter exchange:

If the Indicating Transmitter is exchanged, then all parameters and configuration determinations have to be changed.

Sensor exchange:

To substitute a Sensor by a spare Sensor calibrated for the same range, keeping the Indicating Transmitter, the ten constants in the "sensor adaption" zone (Figure 5.70) have to be entered according to the constants of the spare sensor, see the DELIVERY DATA SHEET. If the Sensor is calibrated for another process medium, the Bias, Gain, Square and Cube have to be determined by Field Calibration (Section 5.3).

The calibration constants:

- Concentration linearization: Bias, Gain, Square, Cube. Normally a 6 character number (.and - included). Enter from Calibration/Parameters/CONC/Parameters.
- Temperature compensation: TNM, Temp coeff, Temp TC adj. If Temp coeff = 0 and TC adj = 0, then there is no temperature compensation. Enter from Calibration/Parameters/CONC/Parameters.
- Linearization of Standard RI (25°C): RI-Bias/Gain/Square/Cube. The values are specific for each sensor. Enter from Calibration/Parameters/Standard RI.
- Temperature adjustments: TMPC0, TMPC1 are factory adjusted and specific for each sensor. For Tbias, see Section 5.8. Enter from Calibration/Parameters/Temperature.

5.8. TEMPERATURE CALIBRATION

Normally the process liquid temperature is considerably higher than the ambient. Then the heat loss through the Sensor may cause the temperature display to be somewhat lower than the process temperature. This will not impair the measurement, and the difference can be ignored.

If, however, the temperature has to show an absolutely correct value, then a bias in °C can be added to the temperature reading, "Temperature bias".

Note: A change of Temperature bias will cause a small change in the concentration output, due to the temperature compensation.

5.9. INSTRUMENT VERIFICATION

A company maintaining its quality system according to ISO 9000 quality standards must have defined procedures for control and calibration of its measuring equipment. This is for demonstrating the conformance of final product to specified requirements.

The company should:

- identify the accuracy required and select an appropriate equipment for the measurements
- establish calibration procedures, including check method and acceptance criteria.
- calibrate the equipment at prescribed intervals against certified equipment having a known valid relationship to nationally recognized standards. Where no such standard exists, the basis used for calibration shall be documented.

This Section serves the users of K-Patents Process Refractometer PR-03 in meeting the above requirements. K-Patents quality system is certified against ISO 9001 by Det Norske Veritas. K-Patents verifies the calibration of all delivered instruments according to similar procedure as described in this section.

5.9.1. DEFINITIONS

Many of the definitions used in this instruction have a special meaning related to the instrument. The terms defined below apply to PR-03.

Refractive Index (R.I.) calibration

Calibration of PR-03 with standard refractive index liquids: As a result of calibration procedure, a set of R.I. parameters are calculated: RIBias, RIGain, RISquare and RiCube. These parameters define the calibration polynome, used for refractive index measurement with a reference temperature of 25°C.

The Refractive Index (R.I.) calibration can be traced to national standards, whenever certified standard R.I. liquids are used in the calibration.

Accuracy of R.I. calibration

Maximum deviation accepted in R.I. calibration: The total acceptable deviation for PR-03 is R.I. 0,0006. This comes from the accuracy of PR-03 (R.I. 0,0002) and from the accuracy of the standard R.I. liquids used in the calibration (R.I. 0,0002).

Repeatability of the R.I. calibration

Deviation from the latest R.I. calibration of PR-03: The repeatability of PR-03 is R.I. 0,0002. This can be verified as described in the following section.

5.9.2. VERIFICATION OF REFRACTIVE INDEX (R.I.) CALIBRATION

The R.I. calibration can be verified with three certified standard R.I. liquids as follows:

- 1 Take the sensor from the process and mount it on a service bench.
- 2 Allow the sensor temperature to settle close to 25°C. The temperature does not have to be exactly 25°C, since the differences in the calibration temperature are compensated by the software.
- 3 Ensure that the prism is clean from process medium. Use a cleaning solvent appropriate for the process medium.
- 4 Use the certified standard R.I. liquids, which corresponds to the values indicated in the Final test - section of the latest Delivery data sheet or Standard calibration sheet of the PR-03. The three R.I. values are selected by K-Patents calibration software to represent the used R.I. range.
- 5 Check the R.I. calibration with the three R.I. liquids. The use of K-Patents PR-03 sample holder, PR-1010, is recommended to ensure a right portion of liquid on the prism.
- 6 The R.I. calibration can be checked against the standard R.I. liquid values as follows:

Display	Key-in sequence from Normal Display	Value to be checked	Acceptable value
Information display	D	Standard RI (25°C)	Sample R.I. \pm 0,0006

5.9.3. CORRECTIVE ACTION IF THE VERIFICATION FAILS

If the verification does not meet the acceptance criteria defined in section 3, then the following steps can be taken to correct the calibration of PR-03.

- 1 Ensure that the prism is in good condition:

See Section 6.7 for more details of prism mounting and dismounting.

- 2 The following values and diagnostics should be checked from the Indicating transmitter displays with the standard R.I. liquid on the prism.

Display	Key-in sequence from Normal Display	Value to be checked	Acceptable value
Raw sensor data	C-A	LED	below 200
Image diagnostics	C-A-A-A-A	Max intensity OK	Yes
		Endpoint below 75%	Yes
		Image below corner	Yes
		Slope OK	Yes
		Left curve OK	Yes
		Right curve OK	Yes

If the above checks 1 and 2 fail, please contact K-Patents or its international representative for corrective action.

- 3 If the above check criteria are met, the instrument can be calibrated. Calibration is done with minimum five, preferably seven, standard R.I. liquids as follows:
- 3.1 Mount the sensor on the service bench.
 - 3.2 Take certified standard R.I. liquids. The middle value should correspond to the middle value indicated in the Final test -section of the latest Delivery data sheet or Standard calibration sheet of the PR-03. Then take 2-3 values above and below this middle value.
 - 3.3 Record R.I. value and corresponding Test and Temperature values from the Normal display of PR-03.
 - 3.4 Send the values table to K-Patents or to K-Patents' international representative.
 - 3.5 K-Patents calculates new calibration parameters for R.I. measurement.
 - 3.6 Key in the new parameters (soft keys C-B-6-1/2/3/4) and then repeat the verification check as described in section 2.

6. MAINTENANCE

6.1. REGULAR MAINTENANCE

The need for regular maintenance is minimal, due to the construction with no moving parts, no trim pots and with a solid-state light source. The following rules apply:

- Keep the sensor head and the Indicating Transmitter clean and dry.
- Check that the ambient temperature is not above +45 °C (113 °F). The sensor head should not be too hot to keep a hand on.
- Check that the prism wash works, see Section 8.1.
- Once a year check that the prism surface is smooth and clean. To replace prism or gaskets see Section 6.7.
- The PR-03 sensor has an internal moisture detector, see below. The reading is obtained from the Indicating Transmitter display (Key sequence: Display/Sensor Head). Check that reading once a month. An increasing signal indicates condensate forming in the sensor head (if the process temperature is below ambient) or prism leakage. If the moisture reading exceeds 30%, change the drying agent. If the reading exceeds 50%, check the prism seals.
- The drying agent is contained in a perforated aluminium case inside the sensor head cover. The drying agent should appear blue through the window in the aluminium case. Regenerate the drying agent by keeping the perforated aluminium case in a 130 -150 °C oven for a few hours or dry it with a hot air blower.

6.2. DIAGNOSTICS

For a systematic approach to the identification of a faulty component a basic understanding of the operation is necessary. Read sections 2.3 to 2.8 for general information. Use flow diagram Figure 6.20 for guidance.

The trouble shooting normally starts with a check of the Diagnostic message (Table 6.30). Remember that a sluggish or irregular output signal can result from unfavourable process flow conditions, section 3.1.

Figure 6.21 gives a general description of the information and power flow between different parts of the total system. Section 6.4 gives a complete description of the Indicating Transmitter. Figure 6.22 shows the signals cable. Section 6.5 describes the Sensor and the optical image. Section 6.6 gives the details of the temperature measurement.

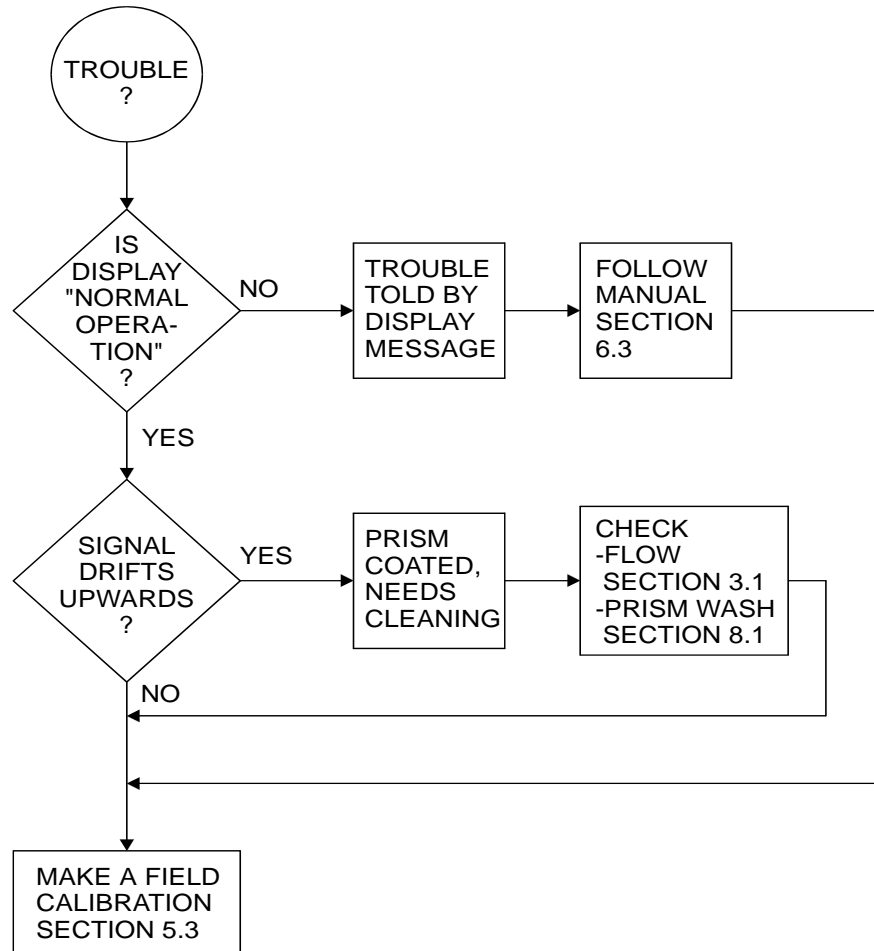

Figure 6.20 Diagnostics guide.

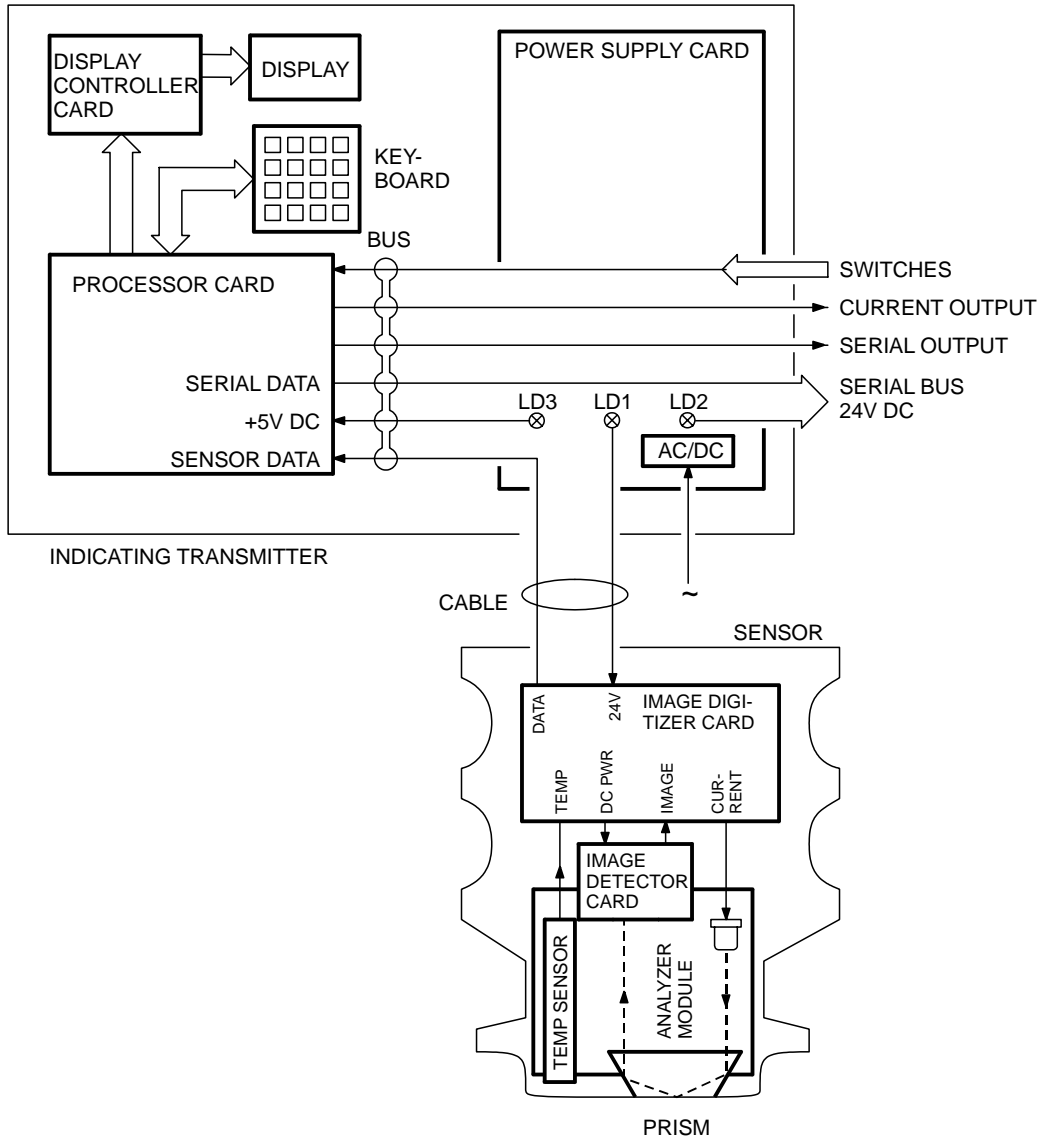

Figure 6.21 Information and power flow.

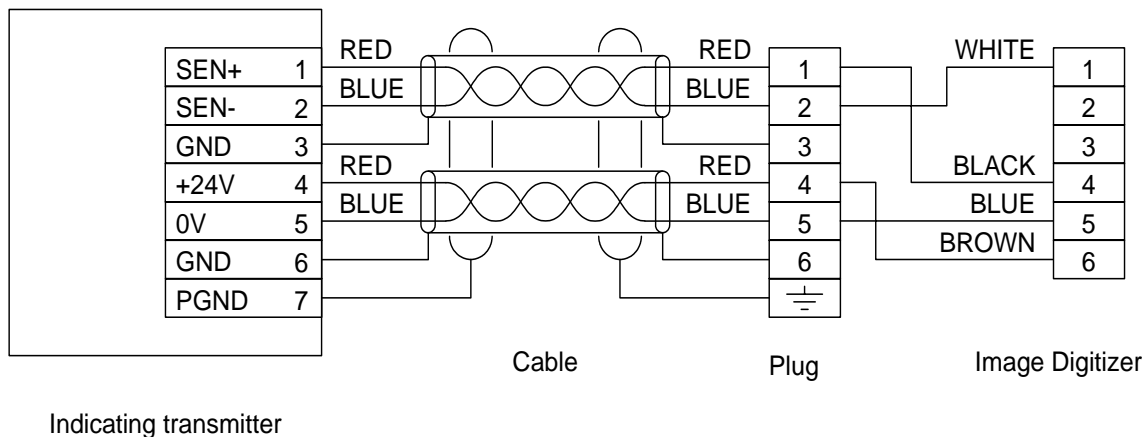

Figure 6.22 Cable signals.

6.3. DISPLAY MESSAGES

The diagnostic messages and the phase codes are listed in Table 6.30. The diagnostic messages are listed by increasing priority. E.g. if we simultaneously have "Temp measurement fault" condition and "No sensor signal" condition, the display message will be "No sensor signal".

NORMAL OPERATION:

If the CONC% display is not according to specifications, take samples and use Calibration Data Report, Section 5.3. Also check that the prism surface is clean.

DIVERT CONTROL:

Divert control is not used in the PR-03. If such message occurs, then deactivate according to Section 2.8.

RETRYING WASH:

The prism wash has failed the wash check, and will repeat the wash as many times as is set by the parameter "Wash retry", Section 9.2.

WASH STOP / TEMP. LIMIT:

Caused when the Wash stop is active and the process temperature is below temperature limit, Section 9.2. The message is shown until wash succeeds or the RESET key is pushed.

LOW CONCENTRATION/NO SAMPLE:

Probably caused by exceptionally low concentration or empty process pipe.

Action: If sample determination indicates normal concentration, then check optical image, Section 6.5, decision according to Figure 6.54.

HIGH PROCESS TEMPERATURE:

The process temperature exceeds the "High temperature limit" set from keyboard after Calibrate/Temperature (Section 2.8.5). This alarm can be enabled/disabled. The cause may be abnormal process conditions or a leaking prism wash steam valve.

LOW LIGHT INTENSITY:

The shadow edge is still detected, but the light intensity is low, see Figure 6.54. This message probably indicates onset of prism coating.

DIP IN IMAGE:

Inspect the optical image for irregularities. Missing or low pulses in the light area may be caused by a speck of dust on the CCD window.

HIGH CONC/PRISM COATED:

Indicates prism coating.

Action: Clean the prism surface. Use a strong solvent like nitric acid. If message persists, check optical image, Section 6.5, decision according to Figure 6.54.

Note: May be caused by exceptionally high concentration.

****WASH STOP / EXT. STOP**:**

Caused if an input switch is activated for external wash stop and the corresponding input switch is closed, Section 2.8.

PRISM WASH FAILURE:

The TEST value during prism wash did not exceed "TEST limit" or did not increase more than "TEST difference", Section 9.2.

**** EXTERNAL OUTPUT FAULT **:**

The External Output unit (Section 10.1) did not acknowledge the transmission. Serial bus or Output unit failure or the Output unit is disconnected.

To prevent this message when the Output unit is disconnected, key in Calibrate/Parameters/Output signals/External output/Source and select: "Not defined".

**** RELAY UNIT FAULT **:**

The Relay unit (Section 9.) did not acknowledge the transmission, Serial bus or Relay unit failure. Maybe the Relay unit is not connected.

To prevent this message when the Relay unit is disconnected, key in Calibrate/Parameters/Relays/Relay unit and select "Not defined" for each relay.

**** TEMP MEASUREMENT FAULT **:**

Indicates that the temperature value reported by the sensor corresponds to a value below -50 °C or above +250 °C by a margin of 10 %. Probably temperature sensor failure, see Section 6.6.

If "Temp. measurement fault" the temperature will be set to TNM (one of the CONC(RI) parameters). This value is then also used in the temperature compensation, which means that the output will be reasonable even at temperature measurement failure.

Action: Change temperature sensor.

**** PRISM COATED/LED FAULT **:**

Light intensity too low, probably due to coating.

Action: Clean the prism surface. Use a strong solvent like nitric acid. If message persists, check optical image, Section 6.5, decision according to Figure 6.54.

HIGH INTERNAL HUMIDITY:

Caused when humidity inside the sensor is higher than 50%.

Action: Remove the sensor from the process line and check it, see Section 6.1.

HIGH INTERNAL TEMPERATURE:

Caused when the temperature inside the sensor is higher than 60 °C (140 °F).

Action: Improved air-cooling is recommended, see Section 3.1.

**** DETECTOR TIMEOUT **:**

The fault is in the sensor, Section 6.5.

No signal from the Image detector card received by the Image digitizer card. Probably CCD-element or Image detector card failure. The 15 V supply to the Image detector card may be incorrect due to a wrong position of the main power switch, see Section 3.6.

Action:

1. Check the position of the main power switch.
2. Change the Image detector card.

**** SENSOR TRANSMISSION ERROR **:**

The signal from the Sensor to the Indicating Transmitter is irregular. The sensor transmission has overrun or there is a checksum error on the received message. Error is caused by noise in the sensor transmission.

**** NO SENSOR SIGNAL **:**

There is a sensor signal timeout. No signals have arrived during the 1200 ms measurement interval (normally about 5 scans). Probably the interconnecting cable is not connected properly.

**** WRONG CONCENTRATION PARAMETERS **:**

This occurs only if the output unit is selected to be RI (x °C). Then this message occurs if CONC(RI) parameters give a value below 1 or above 2. To reset this message, either key in correct CONC(RI) parameters or change the concentration unit (Select Calibrate/Parameters/CONC(RI)/Unit), Section 2.8..

**** CONSTANTS ERROR **:**

There are constants in the EEPROM outside allowed range. This error stops the measurement process.

Action: Switch power OFF/ON. Then one of two alternatives will occur

1. If the EEPROM has been changed, or the program upgraded:
 - ** Constants are not available **
 - Press ENTER to load default settings
 - Press RESET not to change.

2. If only some constants are wrong:
** There are erroneous constants **
The bad constants can be set to default setting
Press ENTER to correct bad constants

**** SENSOR INTERFACE FAULT **:**

Error on the processor card in the Indicating Transmitter (Section 6.4): The sensor interface processor (87C51) did not respond properly. Probably failure of this processor.

Action: Change the processor card.

**** EEPROM WRITE ERROR **:**

Error on the processor card: The EEPROM did not write constants correctly. Probably component failure.

Action: Change the processor card.

PRECONDITIONING:

Shown when the preconditioning valve is activated by the Relay Unit, Section 9.0.

WASH:

Shown when the prism wash valve is activated by the Relay Unit. The concentration output signal is locked (if the HOLD function is active). The HOLD function can be inactivated from the keyboard, (Section 2.8). The concentration display is never locked, but a large "WASH" will flash when the wash starts.

RECOVERY:

Shown during the time delay after end of prism wash when the concentration output signal is still locked.

HOLD:

Caused by input switch closure, when the switch has been configured as a Hold switch, Section 2.8.

NO MESSAGES:

No message: Measure the mA output signal. If this is OK, then the display is probably faulty.

Note. Ambient temperature above specifications may dim the display.

Code	Diagnostic message	Cause
0	Normal operation	No fault
0	In divert control operation	Not used with PR-03
0	Removed from divert control	Not used with PR-03

Process related faults			
Priority	Code	Diagnostic message	Cause
1	1	Retrying wash	Prism wash attempt failed
2	23	Wash stop / Temp. limit	Temperature below set limit
3	4	Low concentration / no sample	Whole image bright
4	6	High process temperature	Temperature above set limit
5	21	Low light intensity	Image nearly dark
6	22	Dip in image	Optical image not correct
7	7	High conc / prism coated	No shadow edge in image

Equipment malfunctions			
Priority	Code	Diagnostic message	Cause
8	28	Wash stop / ext. stop	Input switch activated for wash stop
9	5	Prism wash failure	Wash fault after retries
10	8	External output failure	No response from output unit
11	9	Relay unit fault	No response from relay unit
12	11	Temperature measurement fault	Temperature out of limits
13	12	Prism coated / LED fault	Light intensity too low
14	24	High internal humidity	Sensor internal humidity too high
15	25	High internal temperature	Sensor internal temp too high
16	14	Detector timeout	No signal from image detector
17	15	Sensor transmission error	Noisy signal from sensor
18	16	No sensor signal	No signal from sensor
19	17	Wrong concentration parameters	Makes R.I. outside range
20	18	Constants error	Wrong EEPROM parameters
21	19	Sensor interface fault	Fault on processor card
22	20	EEPROM write error	Fault on processor card

Phase codes		
Code	Diagnostic message	Cause
0	Blank	Normal operation
23	Precondition	Preconditioning
24	Wash	Wash
25	Recovery	Recovery from wash
26	Hold	Hold after external wash

Table 6.30 PR-03 messages.

6.4. INDICATING TRANSMITTER

Before investigating the Sensor, it is advisable to make sure that the Indicating Transmitter is working. The Indicating Transmitter can be tested separated from the Sensor by the following procedure:

- Power off
- Disconnect cable to sensor
- Power on

Then the diagnostic message should be

"** No Sensor signal **". Any other message indicates fault in the Indicating Transmitter.

The Demo mode, Section 4.3. Disconnect all connections to terminals 1 - 14, and make connection as in Figure 4.30. Then the Serial bus output will work as a sensor head simulator, and the whole Processor card will be checked, see the block diagram Figure 6.42.

Power supply card

The Power supply card is described by Figure 6.40 component lay-out and Figure 6.41 circuit diagram.

The following DC powers are supplied by the card:

1. +5V to Processor card. Should be $5V \pm 5\%$. Typical load about 350 mA, should be below 500 mA. Indicated by the green LED LD3, see Figure 6.40.
2. +24V to Sensor. Typical value $25V \pm 10\%$, indicated by the green LED LD2.
3. +24V to serial bus, to supply accessory units, as the Relay unit, Section 9. Typical value $25V \pm 10\%$, indicated by the green LED LD1.

The Test point "0V", see Figure 6.40, is also the 0V at the Processor Card, in the Sensor and in the serial bus to accessory units.

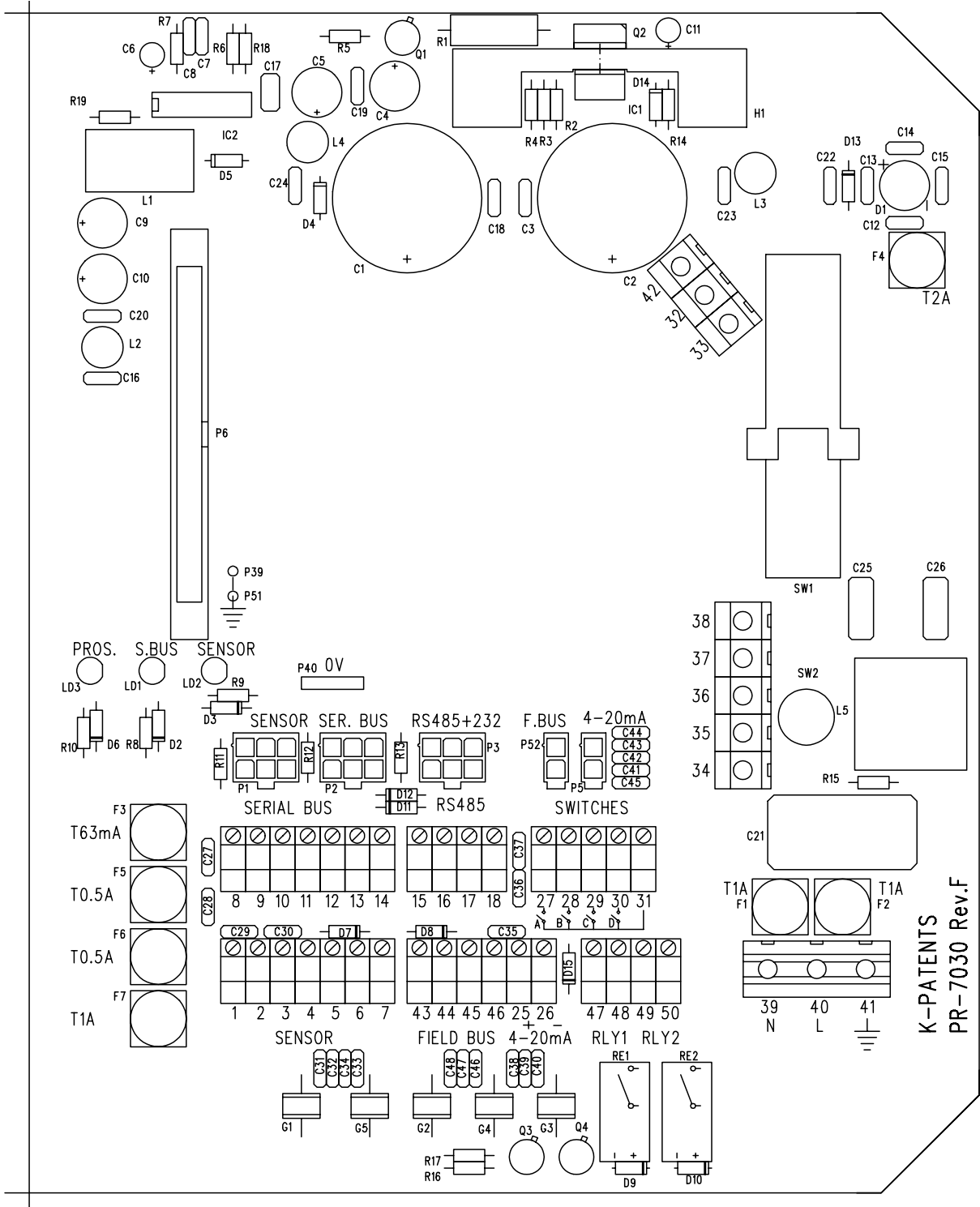

K-PATENTS
PR-7030 Rev.F

Figure 6.40 Power supply card component lay-out.

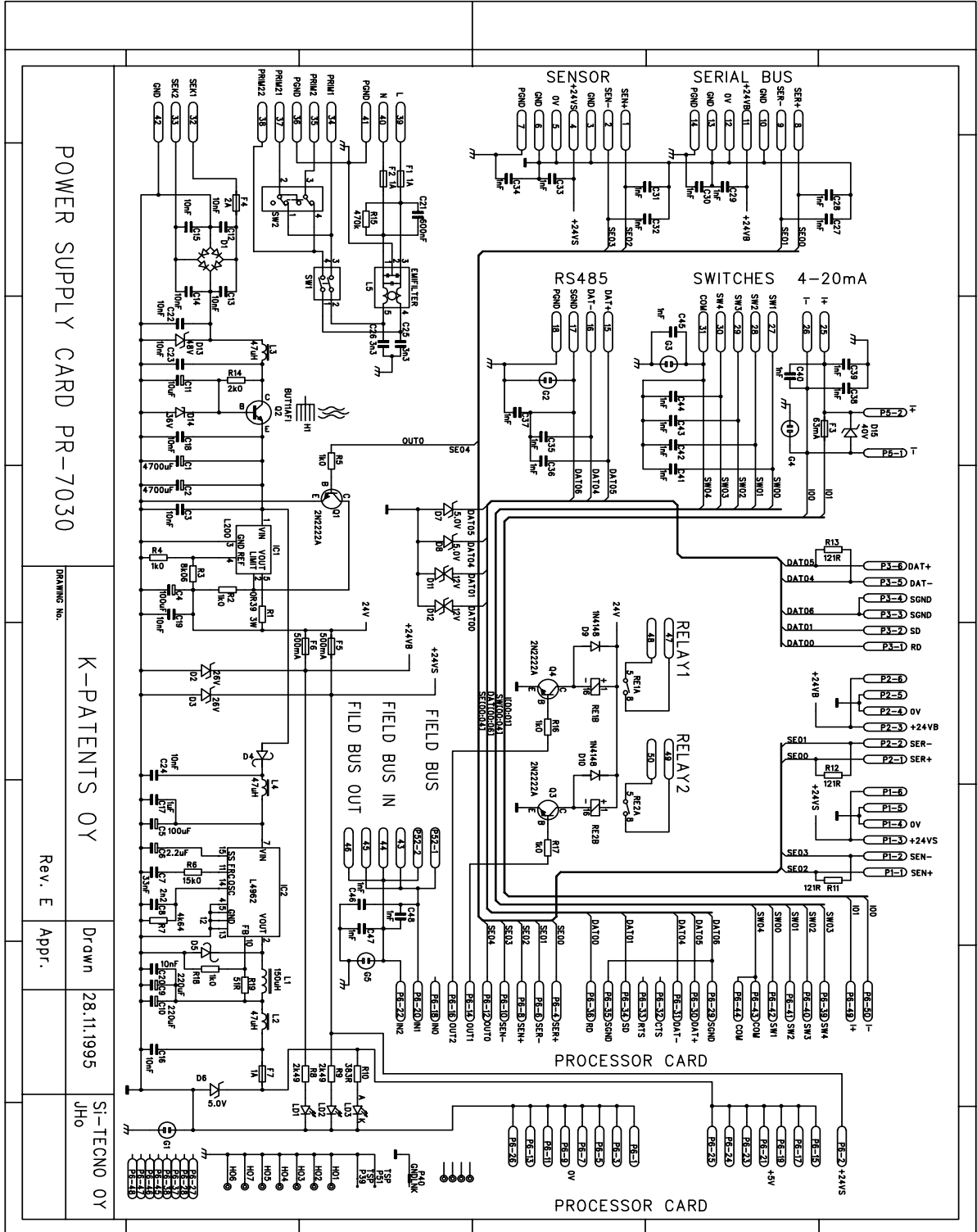

Figure 6.41 Power supply card circuit diagram.

Processor card

The function of the Processor card is described by the block diagram Figure 6.42 and the component layout Figure 6.43.

When measuring voltages on the Processor card it is important to remember that some parts are galvanically separated from each other, see Figure 6.42. It is essential to use the right ground for measurement:

- TP 0V for processor, and also for DC power supply, Serial bus and Sensor.
- TP CLGND is 4-20 mA current loop ground
- TP SGND is RS-232/RS-485 serial output ground
- TP COM is switch input common terminal

Diagnostic LEDs

Two LEDs on the Processor card indicate the CPU (80C186) activity, see Figure 6.43:

LED D3 is lit when the processor is running

LED D4 is lit during interrupt service

Both LEDs should show a blinking light if the processor is working normally. Four rhythms with different intervals are overlapping: 10 ms clock, 150 ms new sensor data, 1200 ms new value calculation, 1 s timer count. The most obvious rhythm is the 1200 ms; first a short D4 blink, then a 200 ms D3 flash. (For PR-01 the measurement interval is 800 ms).

Processor startup errors

The processor hardware is checked on startup. The startup failures are announced as blinking codes on the LED D3. The error code is 1 to 5 blinks on D3 with D4 dark. The error code is the following:

- 1 blink: The chip select unit on the CPU chip (80C186EB) is faulty.
- 2 blinks: The CPU failed the register test. The CPU chip is faulty.
- 3 blinks: The RAM memory failed the address uniqueness test. The memory or its bus interface is faulty.
- 4 blinks: The RAM memory failed the pattern test. There is a bad RAM chip.
- 5 blinks: The code in ROM failed the CRC check. The code is protected with a CRC check. The ROM chip or program pattern in it is faulty.

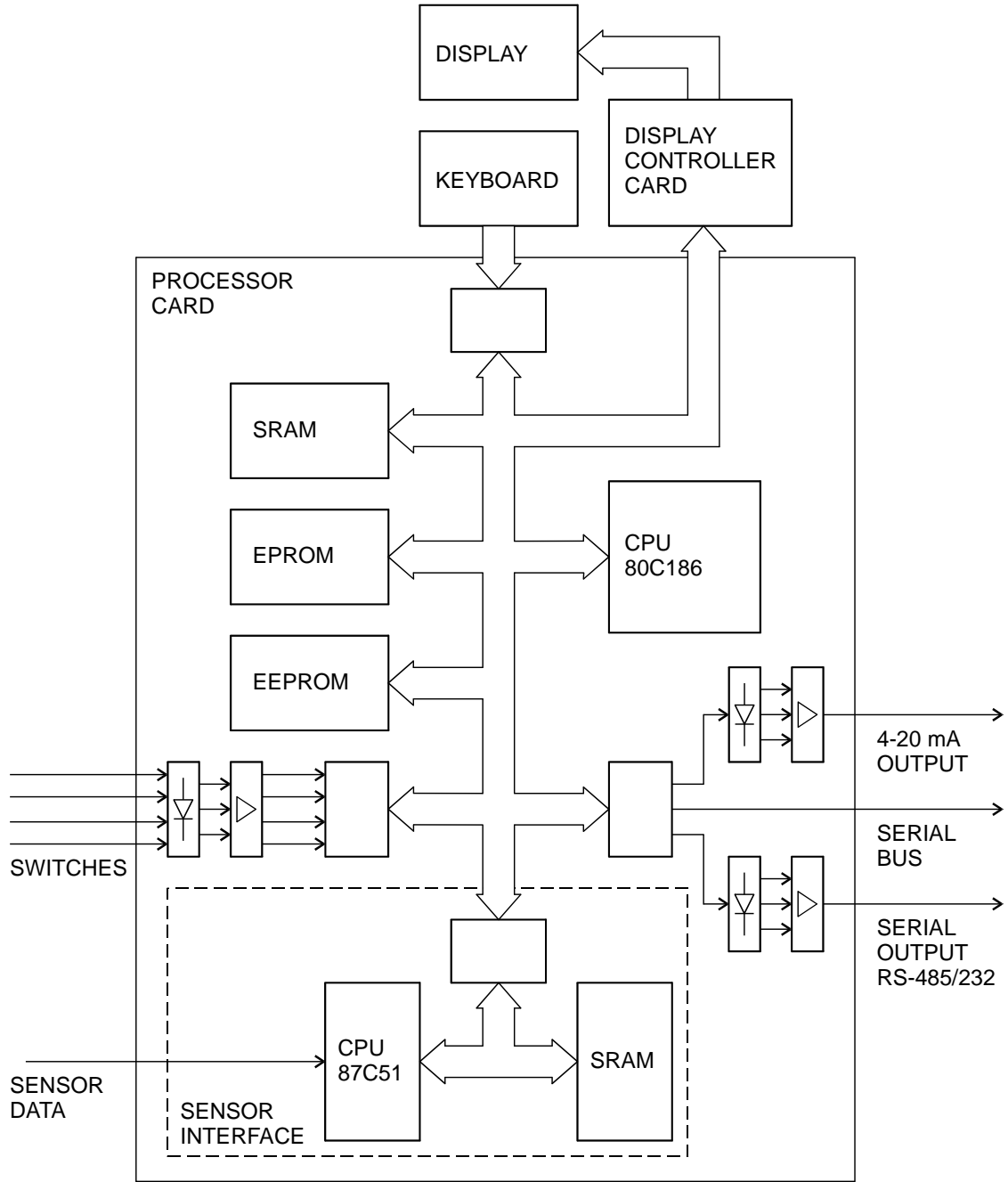

Figure 6.42. Processor card block diagram.

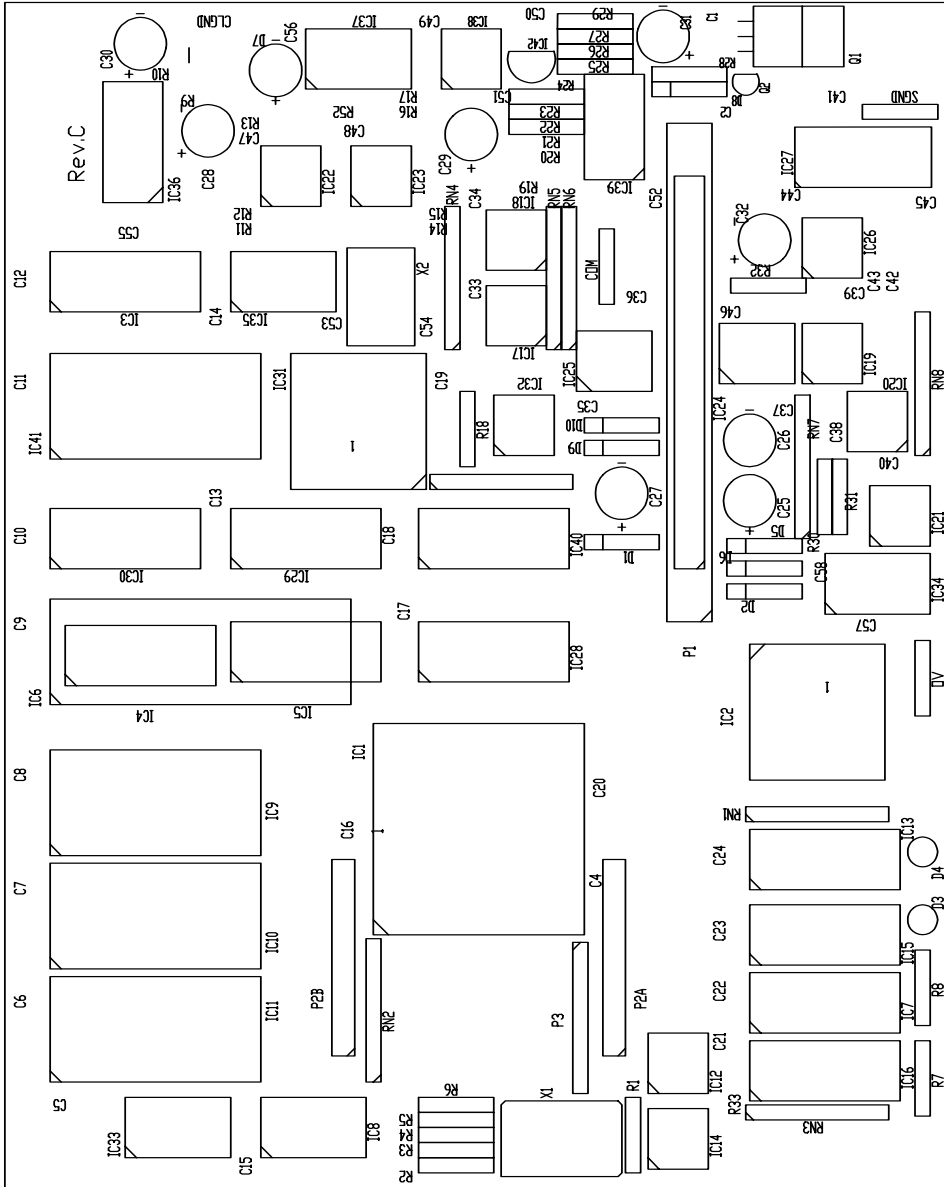

Figure 6.43 Processor card component lay-out.

Display controller card

The Display controller card has the components surface mounted, and it should be considered as one part.

Keyboard

The Keyboard switch matrix is given by Figure 6.46.

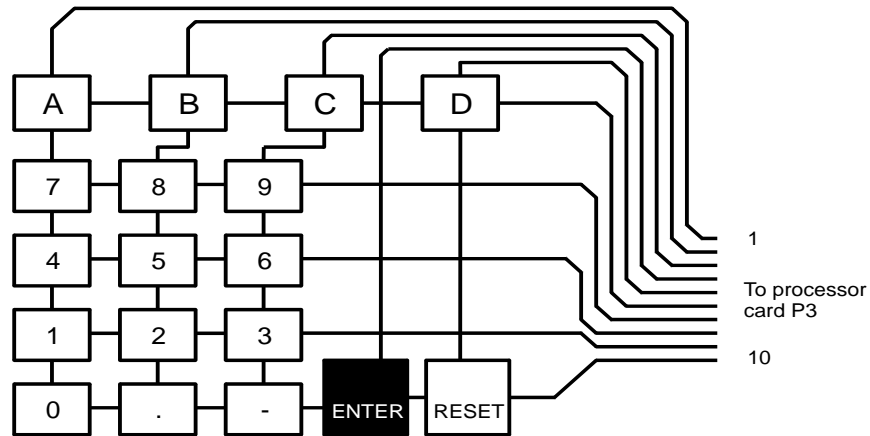

Figure 6.46 Keyboard switch matrix.

Transformer

For transformer colour code, see Figure 6.47. The leads are connected to the following Power card terminals (compare to Figure 6.40):

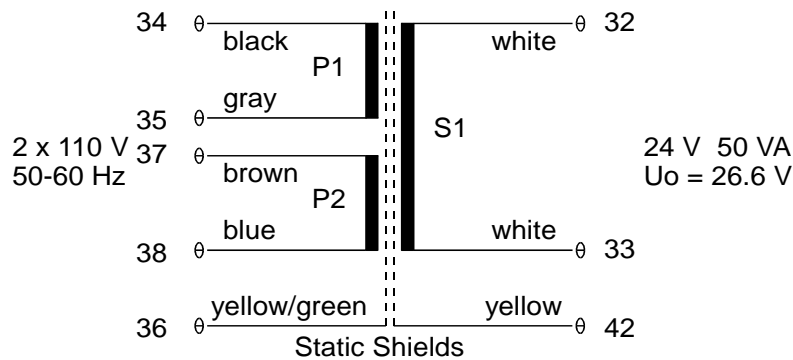

Figure 6.47 Transformer.

6.5. SENSOR CHECK

Study Figure 6.50 to get a basic understanding of how the Sensor works.

Select Calibrate/Optical image from the Normal Display (Figure 2.60). The display (Figure 6.51) contains now all raw data from the Sensor including the signals from each photo cell, i.e. the raw video signal. This differs from the Optical image, Figure 2.72, selected through the "Display" key.

The video signal describing the optical image should look like Figure 6.51. In that case the Sensor is OK, and it should not be touched. If the concentration output does not agree with laboratory values, a Field calibration (Section 5.3) should be done.

The video signal can also be measured directly by an oscilloscope. Use an oscilloscope with a 10 MOhm probe (10x) in AC mode. Connect the signal ground to TP 0V, and the channel to TP4, see Figures 6.52 and 6.50. The duration of one image is 3 ms. The voltage amplitude is 2.5 - 3.7 V corresponding to Indicating Transmitter display 0 - 255.

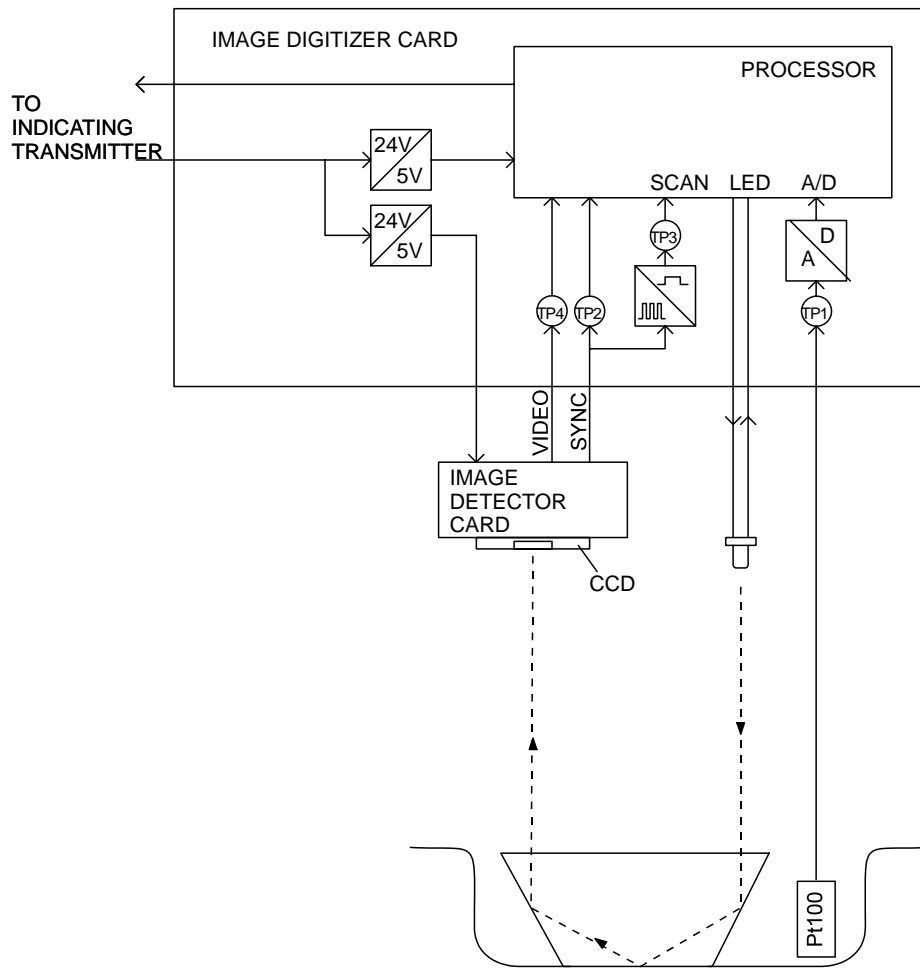

Figure 6.50 Sensor information and power flow.

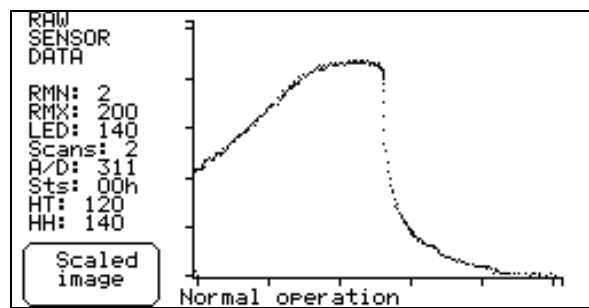

Figure 6.51 Optical image and raw data.

Raw data explanations:

- RMN, RMX:** Minimum and maximum of the raw video signal. This signal is calculated on the Processor card from the video signal. The scale is 0-255, corresponding to full scale on display. The light intensity is controlled to keep RMX in the range 170-190.
- LED:** The LED exposure control signal on a light intensity scale 1-255. The flashing red light of the LED can be seen directly, Figure 6.80. If the operation is correct, the displayed LED value should be above 20 and below 200.
- Scans:** Number of optical images during one calculation cycle, typically 1 or 2. The scan pulses (with 5 V amplitude) can be measured at TP 3 (Figure 6.50).
- A/D:** This refers to the temperature measurement, Section 6.6.
- Sts:** Sensor status bits determined by the type of Image Detector Card: "00h" indicates a standard process refractometer PR-01-S (or NO SENSOR SIGNAL), "02h" indicates an intrinsically safe process refractometer PR-01-S-EX/FM, "04h" indicates a sanitary refractometer PR-03. One bit added, "01h"/"03h"/"05h" indicates DETECTOR TIMEOUT respectively.
- HT:** Sensor head temperature sensor reading. This value is used in calculating the actual Sensor head internal temperature.
- HH:** Sensor head humidity sensor reading. The actual relative humidity in the Sensor is calculated from HH and HT.

Sensor faults:

Sensor faults can be distinguished by the following indications:

The diagnostic message **** No sensor signals ****:

The fault may be in the single path from Image digitizer to the interconnecting cable to the Processor card, see Figure 6.22. If the signal path is OK, then the Image digitizer does not work. Check the 24 V and the 5 V supply to Processor card, Figure 6.52. If the supply is OK, change the Image digitizer card.

The diagnostic message **** Detector timeout ****:

The scan pulses (Figure 6.50) are missing at TP 3 (Figure 6.52). Check the 15 V supply to the Image detector card, Figure 6.52. If the 15 V supply is OK, but the sync signal TP2 is absent, then change the Image detector card. The sync signal is similar to the video signal but the pulse amplitude is constant. Check also the main power selection switch position, see Section 3.6.

Scaled image:

The following display is the scaled image, Figure 6.53. The optical image is now modified mathematically. The following information is provided (where the numbers refer to Figure 6.53):

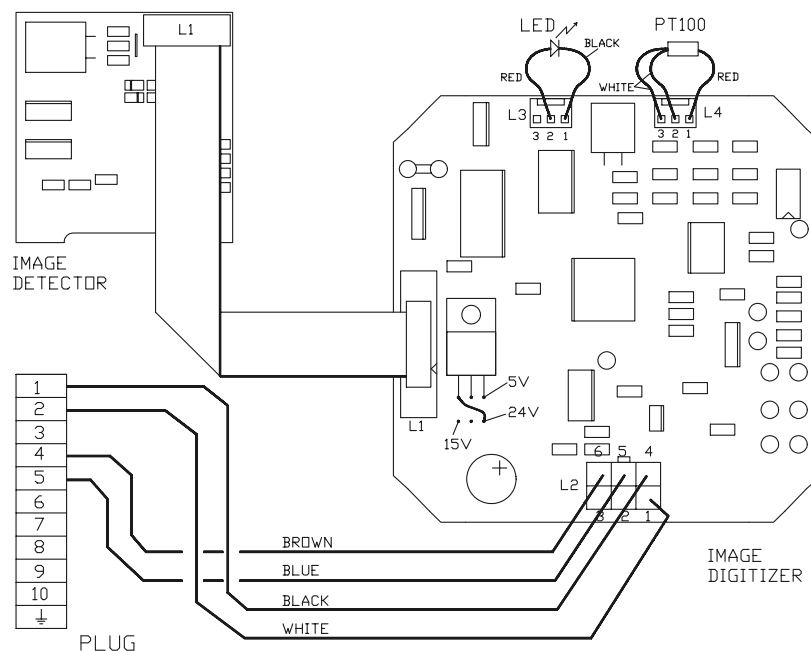

Figure 6.52 Sensor electronics test points.

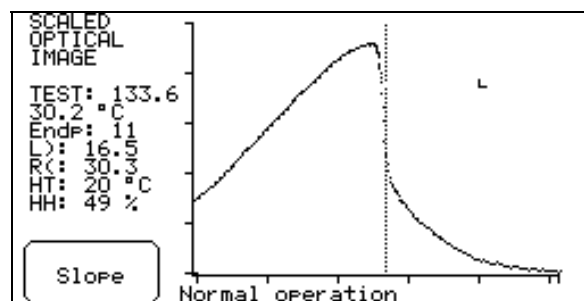

Figure 6.53 Scaled optical image.

1. TEST: The calculated TEST value, range 8...248. Indicated by a dotted vertical line.
- T: indicates the process temperature, to facilitate field calibration
2. Endp: the value of the rightmost point in % of span.
3. L): A measure of the left side curvature of the optical image.
4. R(: A measure of the right side curvature of the optical image.

A zero curvature indicates a straight line. Both curvature values are defined as positive for an image as Figure 6.53.

5. HT: Sensor head internal temperature in °C.
6. HH: Sensor head internal relative humidity in %RH.
7. An L-shaped corner mark. **For a clean prism in air the optical image should form a smooth hill and be above the corner mark.**

Slope:

This display shows the slope curve of the optical image. At the TEST value, the SLOPE curve should have a sharp dip. The following additional values are given:

Max: The filtered value of the maximum light intensity RMX of the raw data (Figure 6.51).

Slope: The absolute value of the slope curve dip at TEST. The value of Slope must be above 1 to be acceptable.

Image diagnostics:

This display lists the critical values for TEST acceptance according to the image analyzer decision rules in Figure 6.54.

Max intensity OK (above 100)? Yes/No

Endpoint below 75 %? Yes/No

Image below corner? Yes/No

Slope OK (above 1)? Yes/No

Left curve OK (above 1)? Yes/No

Right curve OK (above 1)? Yes/No

For measurement with a normal sample, all answers should be "Yes".

A message "Dips in image" appears if the optical image is irregular.

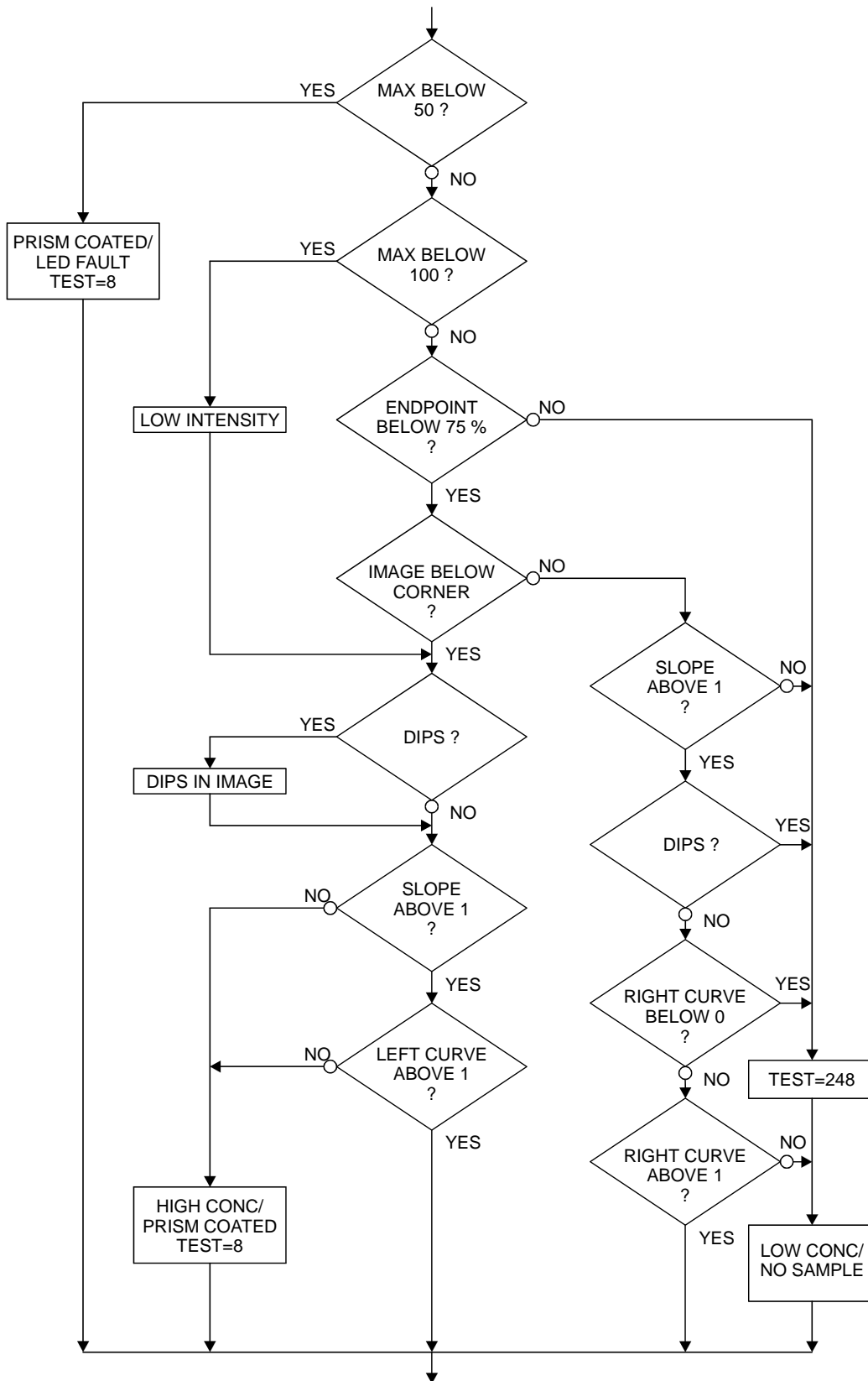

Figure 6.54 Image analyzer decision rules.

6.6. TEMPERATURE MEASUREMENT

The temperature is measured by a Pt100 platinum resistance element, see Figure 6.52. The connector is marked by D in Figure 6.70. The Sensor raw data (Section 6.5) gives the A/D value, which refers to the temperature A/D converter: 0 - 1023 corresponds to 1.8 - 3.0 V corresponding to -75 °C .. 300 °C.

The temperature bias calibration was treated in Section 5.8. The temperature correction parameters TMPC0 and TMPC1 are specific for the Image digitizer card, not for the Pt100 element.

To check the temperature measurement, the Pt100 element can be disconnected from the terminal L4, and substituted by a Pt100 calibrator. Alternatively, terminal 3 and 2 are connected by a jumper, and 2 and 1 by suitable resistors, e.g. 100 Ohm for 0 °C and 138.5 Ohm for 100 °C.

6.7. PRISM GASKET REPLACEMENT

To change the prism gaskets or the prism, use the following procedure:

SENSOR DISASSEMBLY

1. Disconnect the cable. Apply the two connector protection caps. Remove the sensor from the process, and rinse.
2. Fix the sensor by the sensor head (T) in a vertical position, nameplate upwards, Figure 6.70. K-Patents Service stand PR-1002 can be used.

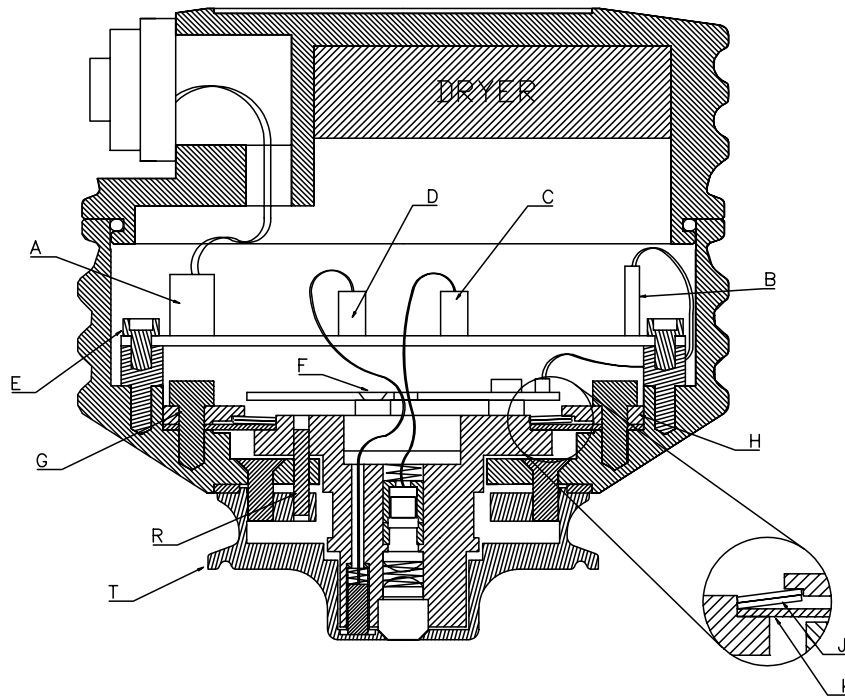

Figure 6.70. Sensor in disassembly position.

3. Remove the nut of the Vee-clamp. Move the Vee-clamp one step downwards.
4. Lift the sensor cover and disconnect the cable (A) from the image digitizer card.
5. Disconnect the ribbon cable (B), the LED lead (C), and the temperature element lead (D).

6. Remove the Image digitizer card kept by four M4 screws (E).
7. Remove the Image detector card kept by three M3 screws (F). Note: Removing the screws may introduce a slight calibration error.
8. Loosen carefully the six M4 screws (G) of the disc spring holder. Turn in small steps, alternating between the screws. Never touch the screws (G) when the instrument is in the line!
9. Remove the disc spring holder (H), the disc spring (J), and the thermal conductor (K).

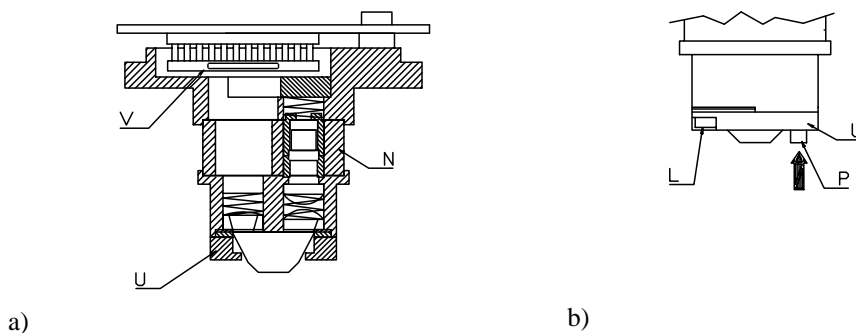

Figure 6.71 The Analyzer module.

10. Lift the Analyzer module, Figure 6.71 (a). The module does not turn due to the alignment pin (R). Note. The thermal insulator (N) is permanently glued at both ends.
11. Remove the Prism support (U) fixed by two M3 screws (L), Figure 6.71 (b).

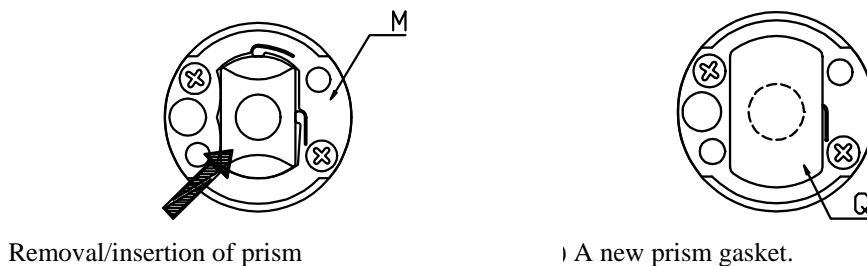

Figure 6.72

12. To remove the prism, push it **gently** against the springs in the prism plate (M), as indicated by an arrow in Figure 6.72 (a).

SENSOR ASSEMBLY

1. Clean the prism. No finger prints on any of the four optical surfaces!
2. Put the prism in place pushing **gently** against the springs of the prism plate (M). The direction of the force is indicated by an arrow in Figure 6.72 (a). To make sure the prism is in correct position, press the prism in the opposite direction of the arrow.
3. Cover the prism by a new prism gasket (with the center hole uncut) according to Figure 6.72 (b).

4. Put the prism support (U) upon the gasket. Keep the gasket in place with a fingertip in the middle. Check that the gasket is symmetrical around the middle of the prism surface. Tighten the screws (L) to the bottom, Figure 6.71 (b).
5. Check that the temperature sensor (P) is properly springloaded. In outer position, the sensor tip is level with the prism surface, Figure 6.71 (b). It should flex inwards 2-3 mm as indicated by an arrow, but return to the outer position.

Now the CORE-optics module PR-9001 is assembled. It should be checked before mounting into the sensor head.

6. Clean the window of the CCD-element (V), Figure 6.71 (a). Attach the Image detector card to the analyzer module by the two screws (F) with conical heads. Connect electrically all cards, with connectors (A), (B), (C), and (D).
7. Connect the indicating transmitter, and inspect the optical image at the RAW SENSOR DATA, key in Calibrate/Optical image.

The optical image must form a smooth curve. Dips or separate single points indicate that the optical surfaces (e.g. the CCD window) are not clean. Important: The prism must be covered to exclude external light.

8. When the image is OK, switch power off and disconnect all cards. Dismount the Image detector card from the analyzer module.
9. Fit the analyzer module into the sensor head. Note the alignment pin (R), Figure 6.70.
10. Mount the thermal conductor (K) with the holes aligned to the screw holes. Mount the disk spring (J). Note the position of the disk spring on the detail (J), Figure 6.70.

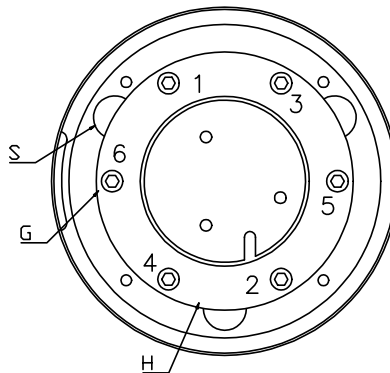
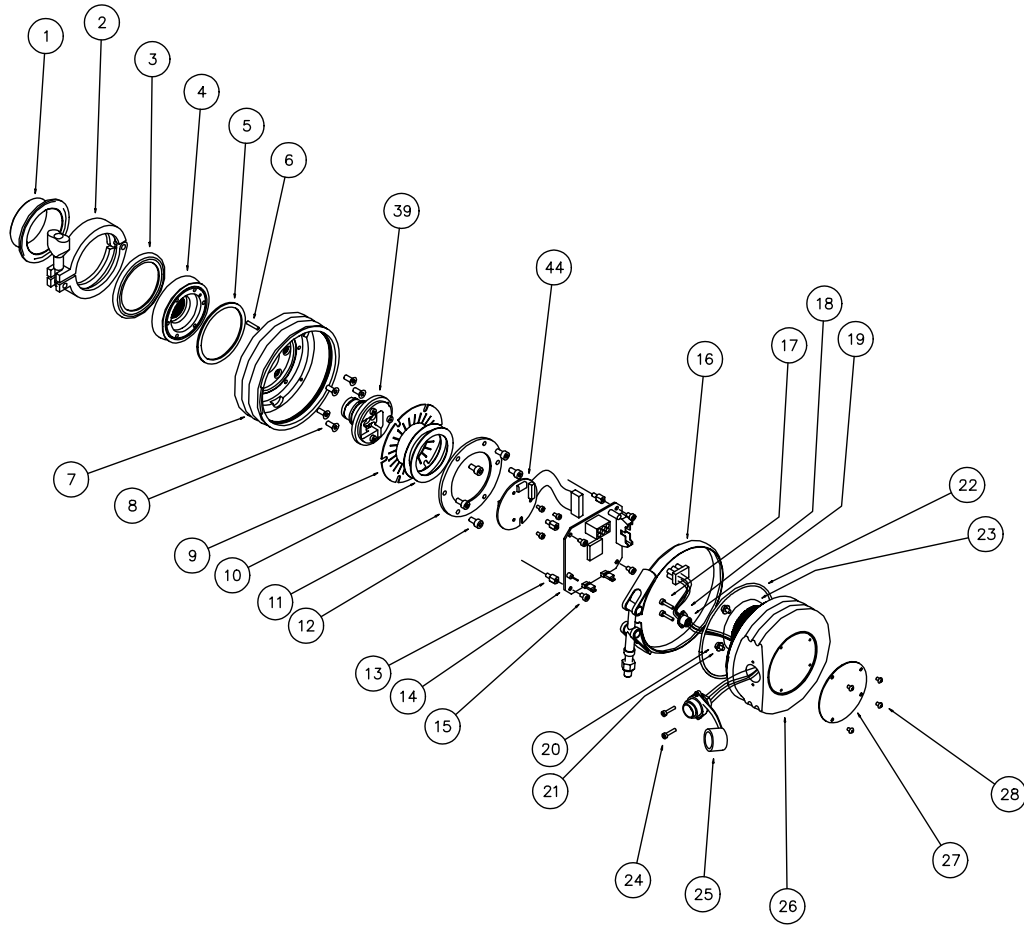

Figure 6.73. Tightening of the disk spring holder screws.

11. Mount the disk spring holder (H). Faster the six screws (G) in small steps following the pattern of numbers in Figure 6.73. Continue until the holder surface is flush to the surfaces of the three notches (S). No step should be felt with the finger tip.
12. Mount the Image detector card with the screws (F), Figure 6.70. First tighten the two guiding screws with conical heads, then the third screw. Lock the screws with e.g. nail polish.
13. Mount the Image digitizer card with the screws (E). Connect (B), (C) and (D).
14. Check the dryer, Figure 6.70: Remove the dryer (held by two screws) and inspect the window at the back. It should be blue. If it is pink, regenerate according to the last paragraph in Section 6.1, before mounting.

15. Connect (A), close the sensor cover and mount the Vee-clamp. The nut and bolt of the clamp should be on the same side as the cable connector.
16. Place the sensor on a table with the prism upwards. Use a sharp knife with a curved edge to cut away the circular piece of the gasket covering the prism. Support the knife on the prism surface only. The knife will scratch the steel.
17. Now the sensor is ready for process installation. Remember to check the calibration (Section 5.2).

7. PR-03 PARTS LISTS



7.1. SENSOR

Item	Pcs.	Part No.	Description	Item	Pcs.	Part No.	Description
1	1	PR-9205	2.5" Sanitary ferrule	*	1	PR-9106	PR-03 Connector complete
2	1	PR-9201	2.5" Sanitary clamp	17	2		Screw M3x8 DIN 912
3	1	PR-9202	2.5" Sanitary gasket EPDM	18	1		Bushing holder
3	1	PR-9203	2.5" Sanitary gasket NBR	19	1		Bushing
3	1	PR-9204	2.5" Sanitary gasket Teflon	24	2		Screw M3x16 DIN 912 A4
4	1	PR-9002	PR-03 Head	25	1		Connector
5	1		Thermal insulator Teflon	20	2		Screw M4x8 DIN 912 A2
6	1		Alignment pin	21	2		Washer M4 DIN 125
7	1		PR-03 Base	22	1	PR-5011	O-ring seal 108x3
8	6		Screw M5x10 DIN 7991 A2	23	1	PR-9107	Dryer
9	1	PR-9011	Thermal conductor	26	1	PR-9110	PR-03 Cover
*	1	PR-9010	Disc spring set	27	1		PR-03 Sensor label
10	2		Disc spring	28	4		Screw M3x5 DIN 7380 A4
11	1		Disc spring holder	39	1	PR-9001	CORE-Optics module
12	6		Screw M5x10 DIN912 A2	44	1	PR-7125	Image detector
13	4		Screw M4x12 DIN				
14	1	PR-7133	Image analyzer				
15	4		Screw M4x8 DIN 912 A2				
16	1	PR-5012	Vee clamp 11-130				

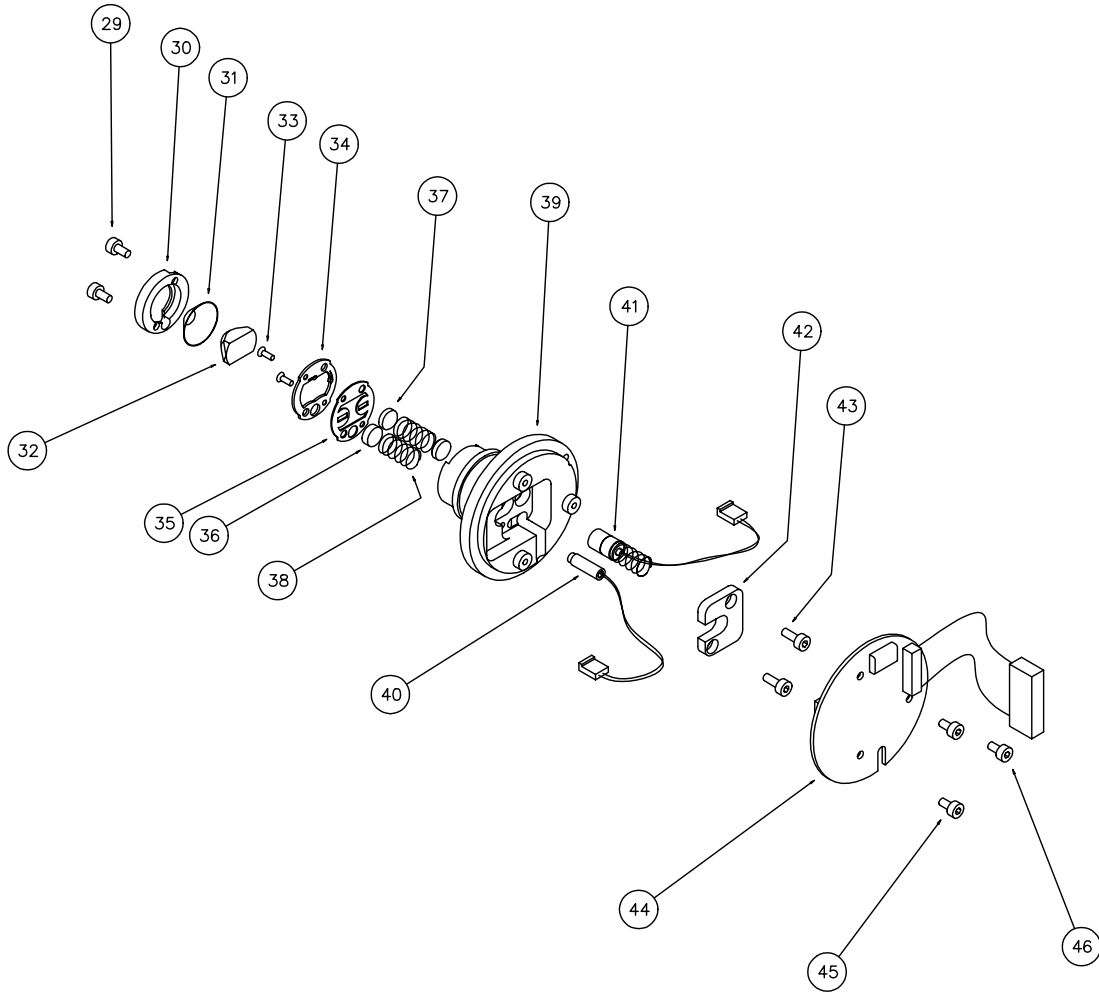

Item	Pcs.	Part No.	Description
29	2		Screw M3x10 DIN 7380 A2
30	1		Prism support
*	1	PR-9004	H62-Prism set
31	1	PR-9003	Prism gasket
32	1		H62-Prism
33	2		Screw M2x5 DIN 965A A2
34	1		Prism plate
35	1		Lens locking ring
36	1		Lens
37	2		Lens
38	2		Pressure spring 7.8x6
39	1	PR-9001	CORE-Optics module
40	1	PR-9250	PR-03 Temperature element assembly

Item	Pcs.	Part No.	Description
41	1	PR-9251	PR-03 LED assembly
42	1		LED plate
43	2		Screws M3x4 DIN
44	1	PR-7125	Image detector
45	2		Screw M3x10 DIN 7991 A2
46	1		Screw M3x10 DIN 912 A2

7.2. INDICATING TRANSMITTER

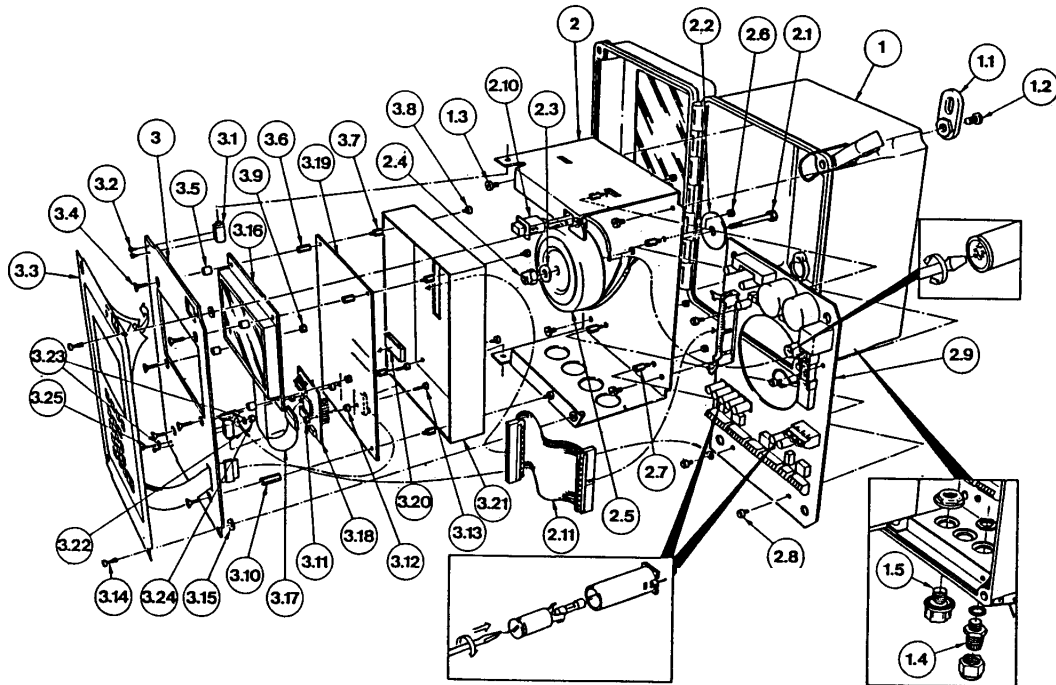

Item	Pcs.	Part No.	Description	Item	Pcs.	Part No.	Description
1	1		Enclosure	3.	1		Front panel
1.1	4		Mounting feet	3.1	2		Hinge
1.2	4		Screws 10-32 pan head	3.2	4		Screws DIN 912 M3 x 10
1.3	4		Screws 10-32 pan head	3.3	1	PR-7305	Key board
1.4	4		Cable clamps PG 11 (European)	3.4	6		Screws DIN 799/DIN 965 M3 x 12
1.5	4		Conduit hubs 1/2" NPT-Type ST-1 (US)	3.5	2		Ferrule 3,0 x 8 x 3
2.	1		Frame plate	3.6	2		Stand-off M3 x 10
2.1	1		Screw DIN 912 M5 x 50 Zn	3.7	4		Stand-off M3 x 15
2.2	1		Washer DIN 9021 5,2 x 18 Zn	3.8	4		DIN 912 M3 x 8
2.3	1		Washer DIN 9021 5,2 x 18 Zn	3.9	2		Nut DIN 934 M3
2.4	1		Nut DIN M5 Nyloc N	3.10	2		Stand-off M3 x 15
2.5	1	PR-7301	Transformer	3.11	2		Nut DIN 934 M3
2.6	4		Nuts DIN 934 M4	3.12	2		Ferrule 5 x 8 x 3
2.7	4		Stand-off M4 x 15	3.13	2		Screw DIN 912 M3 x 10
2.8	4		Screws DIN 912 M4 x 8	3.14	2		Locking screw
2.9	1	PR-7030	Power supply card	3.15	2		Locking washer
2.10	1		Switch actuator	3.16	1	PR-7315	Display
2.11	1	PR-7028	Ribbon cable	3.17	1	PR-7019	Display cable
		PR-7029	Fuse set (10 Fuses: 4 x 1A, 1 x 63 mA, 2.2A, 3 x 0,5 A)	3.18	1	PR-7020	Display controller card
				3.19	1	PR-7010	Processor card
				3.20	1	PR-7009	Program memory
				3.21	1		Cover

8. PRISM WASH SYSTEMS

The use of a Relay Unit to control prism wash cycle is described in Sections 9.2 and 9.3.

Three alternative media can be used for wash: steam, water and high pressure water.

In most of the applications the prism wash is not necessary. However, installing the wash nozzle can be considered for other reasons: A prism wash nozzle (Section 8.3.) can be useful in cases where normally no prism coating occurs, e.g. to clean the prism after a process stop using a manual wash valve. Washing can also be used for operational check (Test value increases during wash) or as a part of maintenance schedule.

8.1. PRISM COATING

Deposit build up on the prism surface disturbs the measurement. Look out for the following indications of coating:

- Abnormally high concentration reading or upward CONC% drift.
- Low TEST values, even TEST = 8.
- High LED value (press Calibrate/Optical image), especially LED = 255 (max) (See Section 6.5).
- Prism wash (e.g. by press Start prism wash) does not increase the TEST value the appropriate amount: For steam wash TEST should be close to 248; for water wash close to the TEST value for water.
- Drop in the Slope value (e.g. from 2 to close 1), press Calibrate/Optical image/Scaled image/Slope.

In most of the applications the prism will keep clean, but if coating occurs, check the following:

- Sensor mounted correctly in respect to flow direction (arrow on sensor head).
- Sufficient flow velocity, Section 3.1.
- A temperature difference between process fluid and sensor probe may cause coating. This may happen for small flows if the thermal insulation is inadequate. In some cases it helps to insulate also the clamp connector.

If there is a coating problem, it is recommended to try to increase the flow velocity, e.g. by installing a pipe portion with smaller diameter. If this cannot be done, the prism should be automatically washed at regular intervals, e.g. by steam or hot water.

8.2. RECOMMENDED WASH PRESSURES AND TIMES

To select a recommended wash pressure use the following table:

			Pressure	
Nozzle	Wash medium	Wash time (seconds)	Normal (over process pressure)	Maximum
PR-3366	pressure water	15	40 bar (600 psi)	70 bar (1000 psi)
PR-3365	steam	3	2 bar (30 psi)	4 bar (70 psi)
PR-3364	water	10	2 bar (30 psi)	4 bar (70 psi)

Table 8.20 Recommended wash pressures and times.

Note. Steam wash:

Do not use longer wash times than is recommended in the Table 8.20. In case of coating adjust the wash interval.

Note. Water wash:

Water temperature should be above the process temperature. Precondition should be used to keep the water pipe hot.

8.3. PRISM WASH NOZZLES

The three versions of a prism wash nozzle are shown in Figure 8.30. How they are mounted to the process is shown in Figure 8.31, which also shows the connection of a check valve.

K-Patents provides flow cells with stud for a wash nozzle. Figure 8.32 shows an example with the correct position of the nozzle in relation to the prism surface.

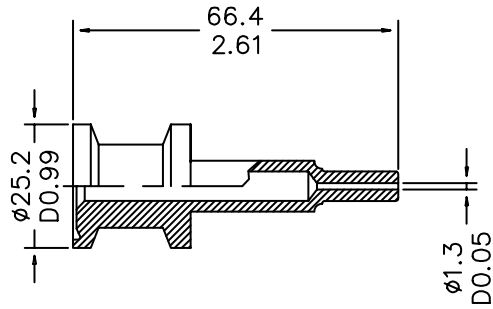

PRESSURIZED WATER SANITARY NOZZLE PR-3366

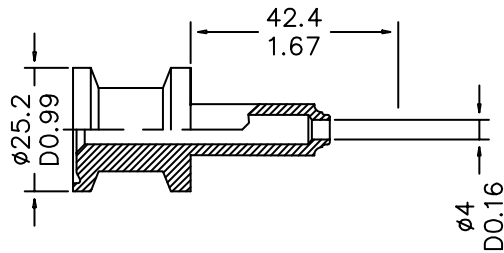

STEAM SANITARY NOZZLE PR-3365

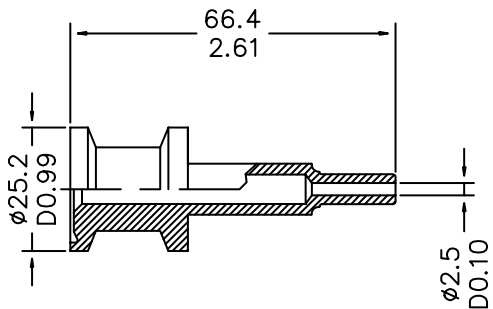

WATER SANITARY NOZZLE PR-3364

DIMENSIONS: mm
in

Figure 8.30 Prism wash nozzles.

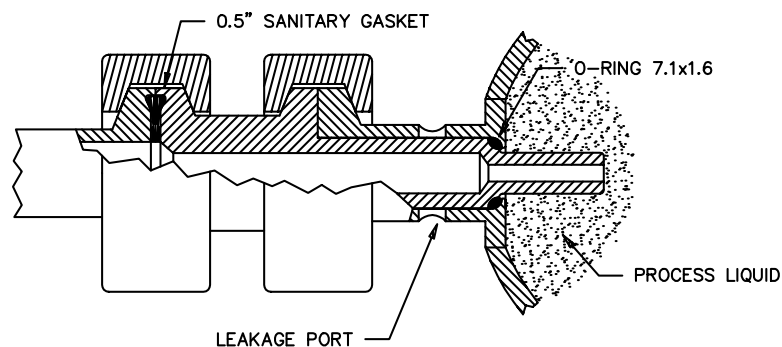

Figure 8.31 Process connection of a wash nozzle.

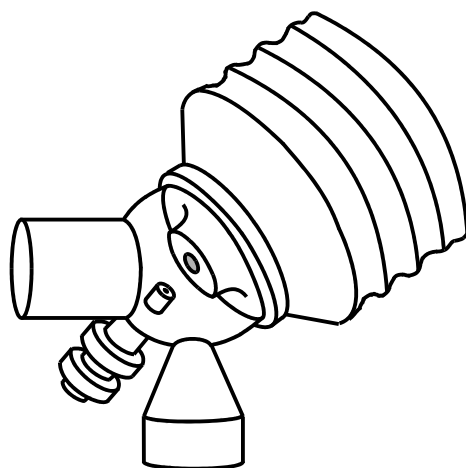

Figure 8.32 Example of wash nozzle installed in a flow cell.

8.4. STEAM AND WATER WASH SYSTEMS

Mounting according to Figures 8.40 to 8.43.

8.5. HIGH PRESSURE WATER WASH SYSTEM

Mounting according to Figure 8.51 to 8.52.

Warning! Pressure increase can occur in a closed pipe section when the high pressure pump is operated. K-Patents recommends to mount a pressure relief valve in the pipe section. Relief pressure should be according to pipe pressure rating.

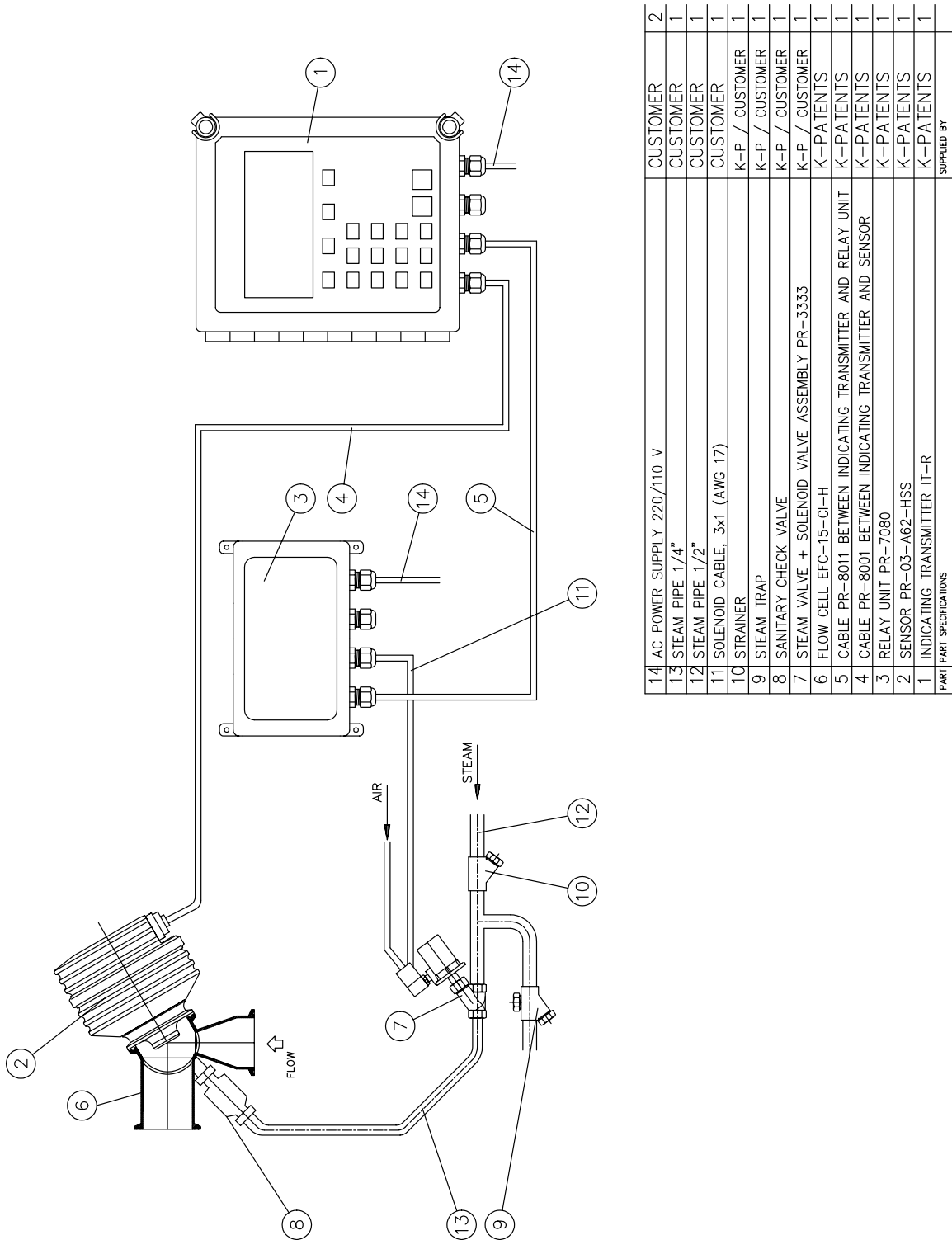
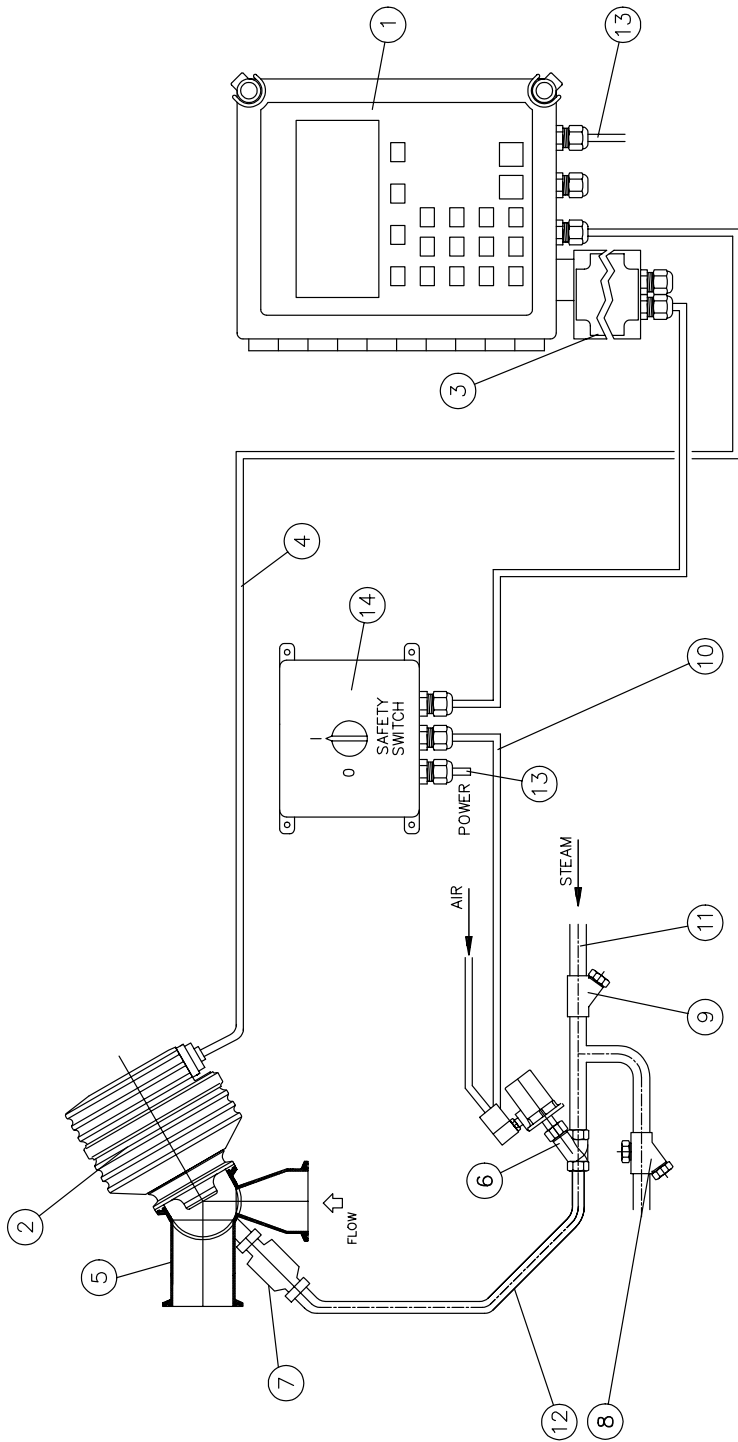

Figure 8.40 Mounting summary of prism wash system for steam with relay unit PR-7080.



14	SAFETY SWITCH	1	CUSTOMER
13	AC POWER SUPPLY 220/110 V	2	CUSTOMER
12	STEAM PIPE 1/4"	1	CUSTOMER
11	STEAM PIPE 1/2"	1	CUSTOMER
10	SOLENOID CABLE, 3x1 (AWG 17)	1	CUSTOMER
9	STRAINER	1	K-P / CUSTOMER
8	STEAM TRAP	1	K-P / CUSTOMER
7	SANITARY CHECK VALVE	1	K-P / CUSTOMER
6	STEAM VALVE + SOLENOID VALVE ASSEMBLY PR-3333	1	K-P / CUSTOMER
5	FLOW CELL EFC-15-CI-H	1	K-PATENTS
4	CABLE PR-8001 BETWEEN INDICATING TRANSMITTER AND SENSOR	1	K-PATENTS
3	WASH RELAY UNIT	1	K-PATENTS
2	SENSOR PR-03-A62-HSS	1	K-PATENTS
1	INDICATING TRANSMITTER IT-R	1	K-PATENTS
PART PART SPECIFICATIONS		1	SUPPLIED BY

Figure 8.41 Mounting summary of prism wash for steam with wash control relay unit –WR.

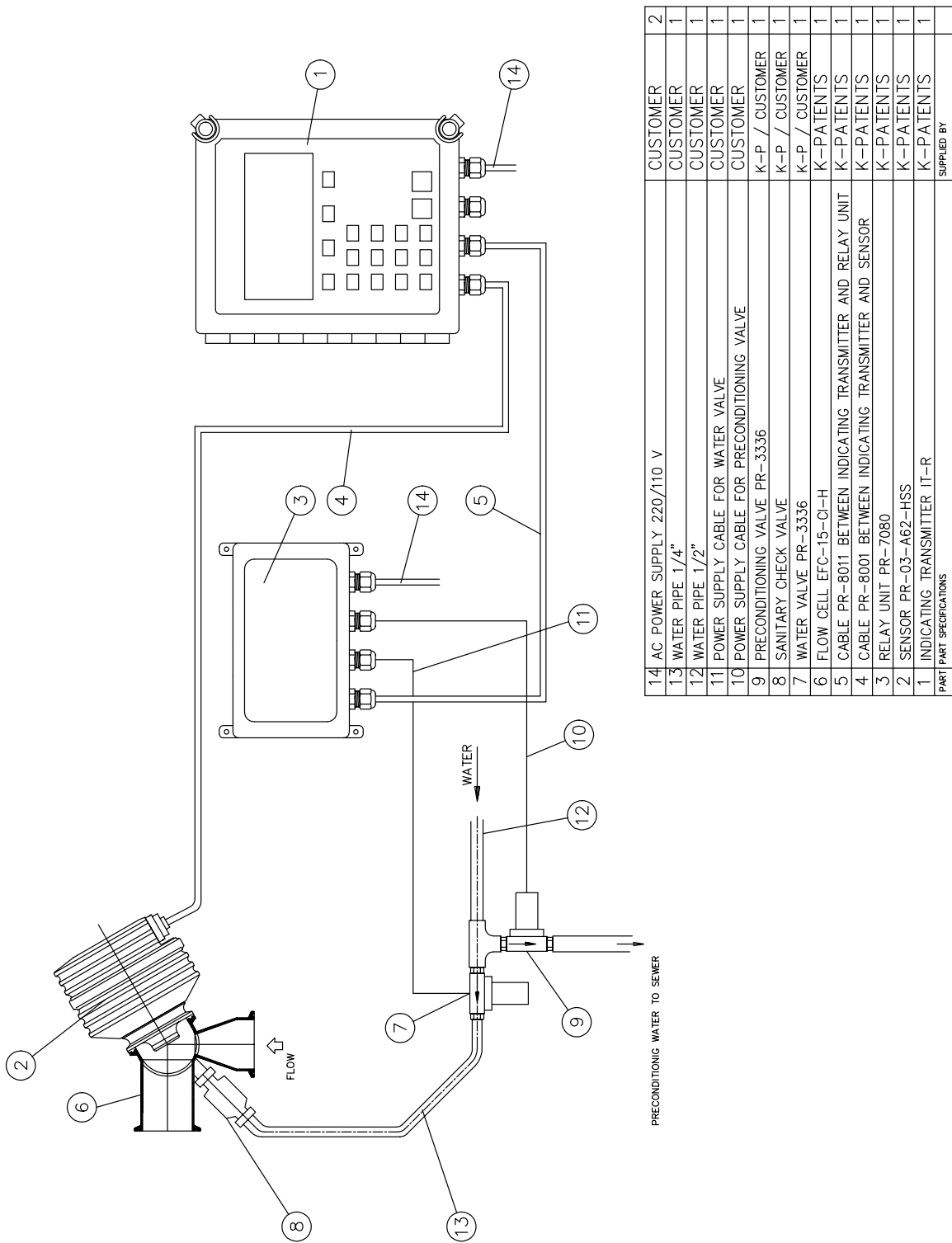

Figure 8.42 Mounting summary of prism wash system for water with relay unit PR-7080.

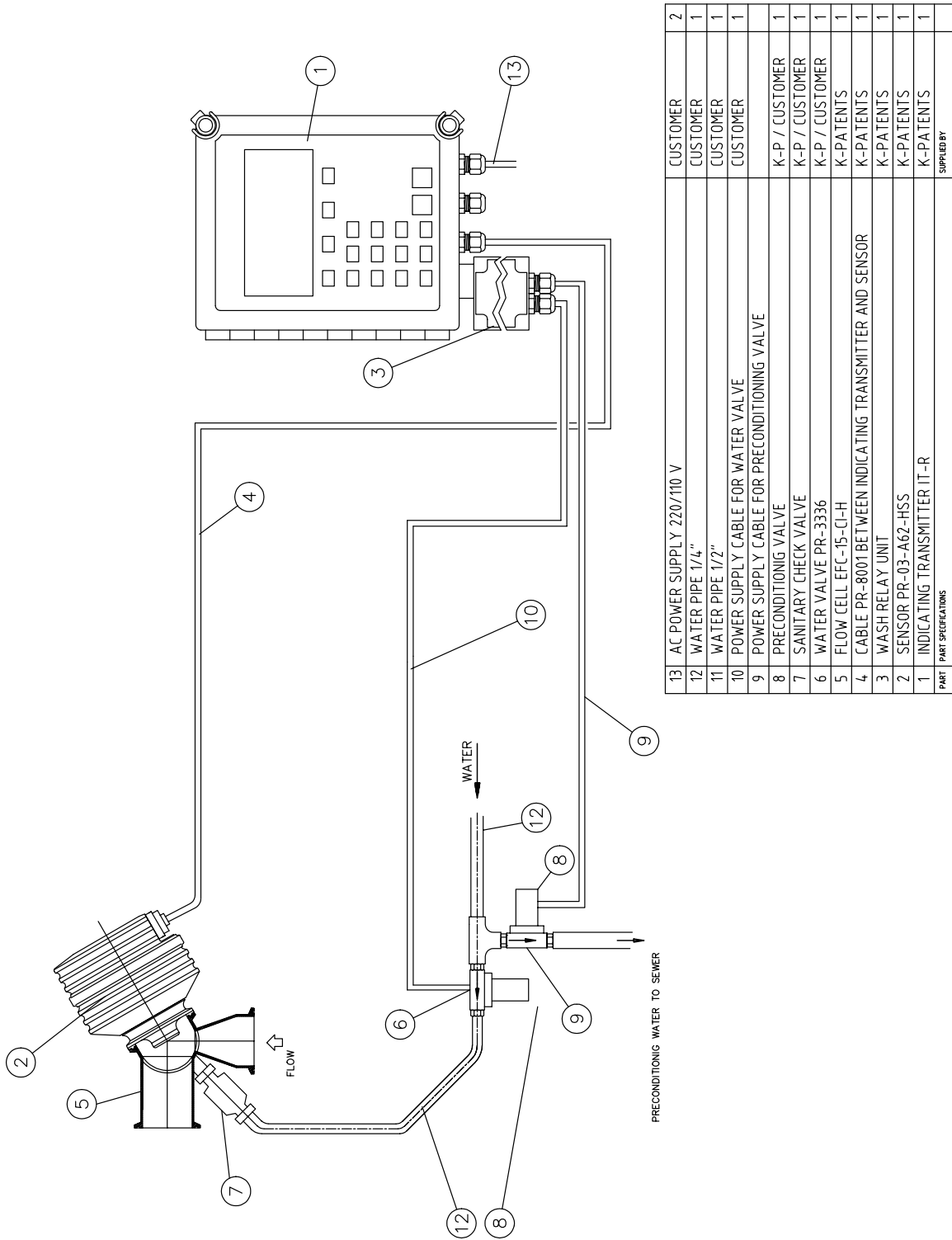

Figure 8.43 Mounting summary of prism wash for water with wash control relay unit –WR.

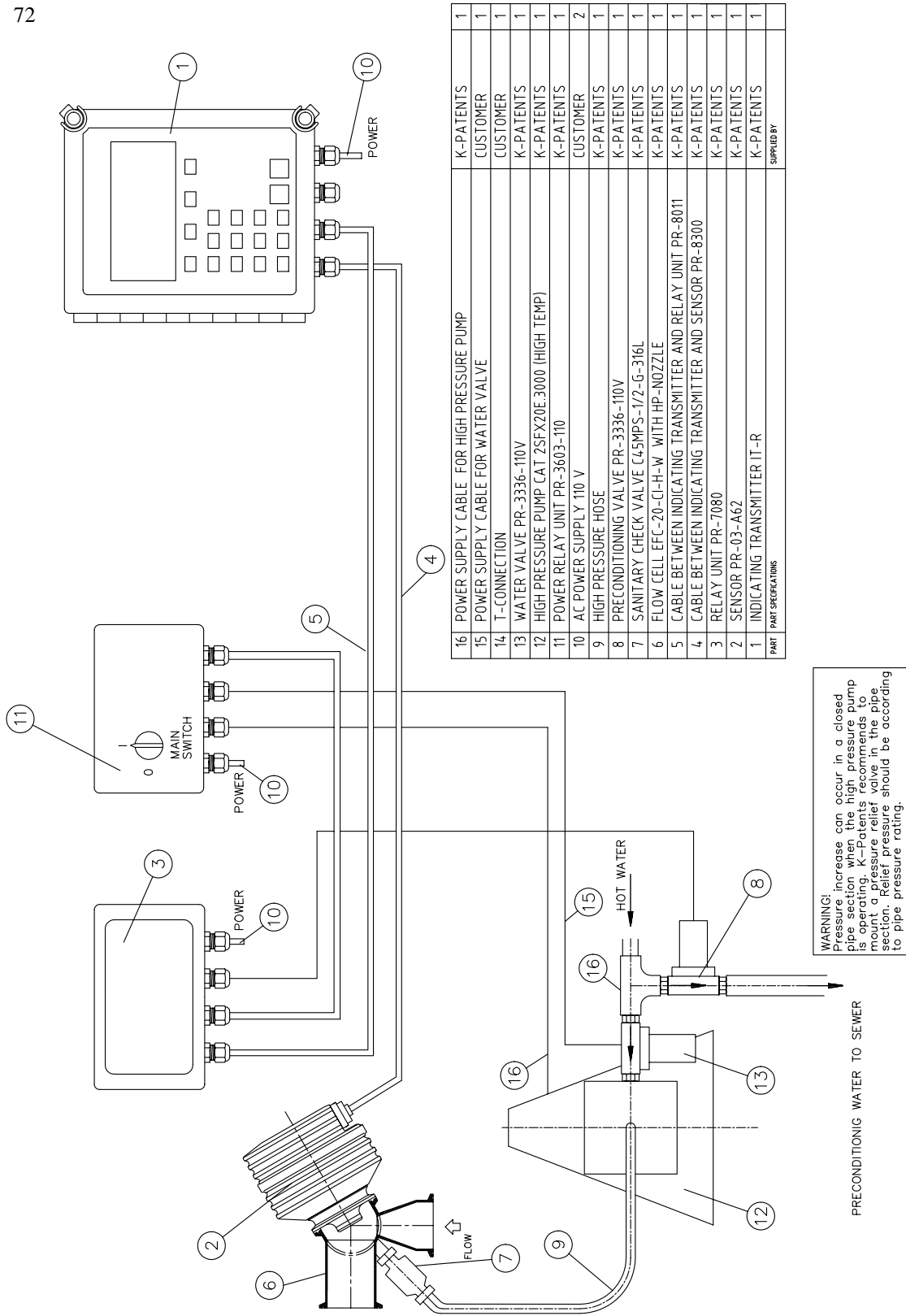

Figure 8.50 Mounting summary of wash system with high pressure water

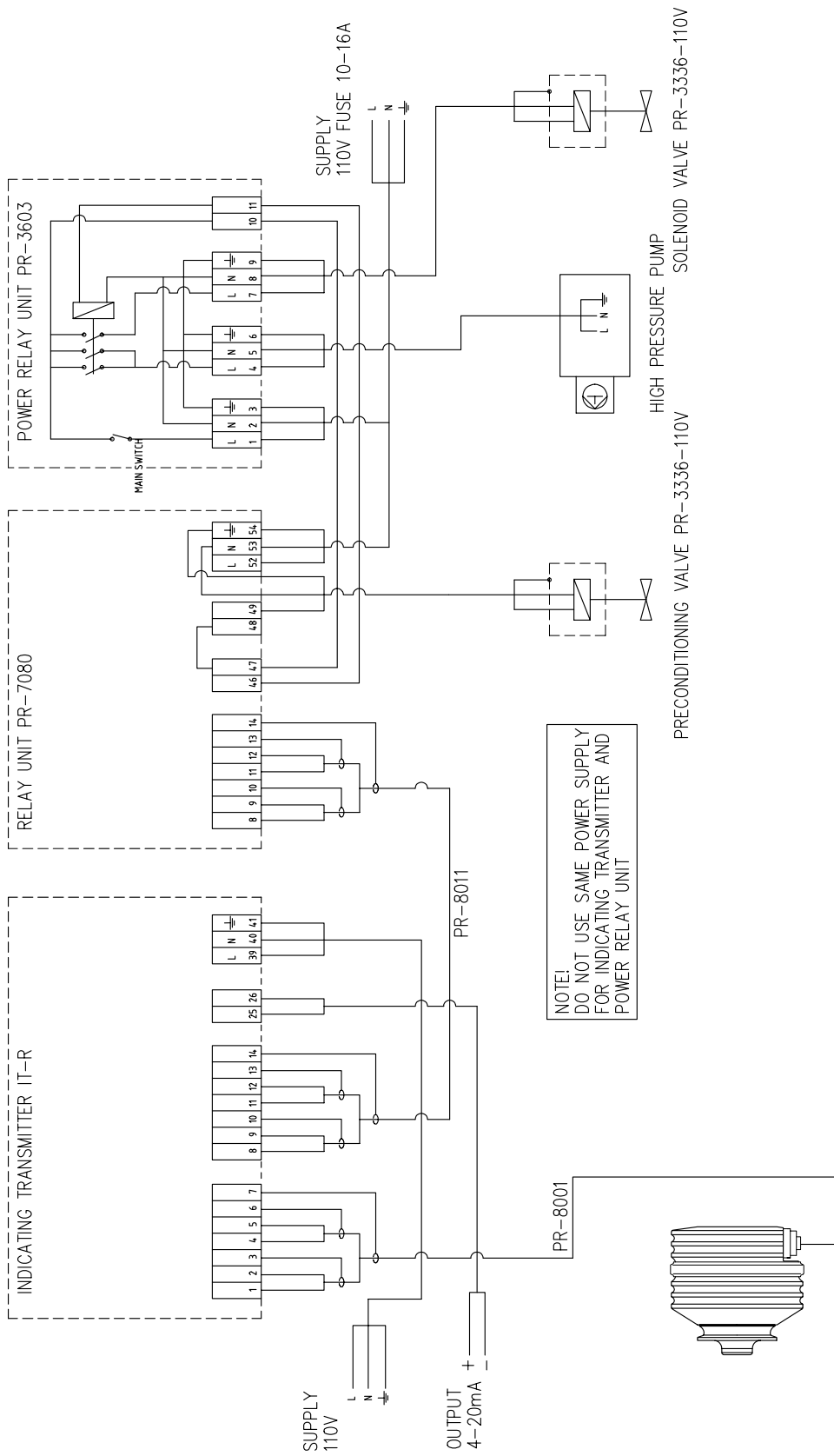

Figure 8.51 Wiring drawing of wash system with high pressure water

9. RELAY UNITS

The K-Patents Sanitary Refractometer can be equipped with a separate Relay unit PR-7080 (4 relays) or a built-in wash control Relay unit -WR (2 relays).

RELAY UNIT PR-7080 (4 RELAYS)

The Relay unit PR-7080 contains 4 relays (Figure 9.01) from left to right: Relay A, relay B, relay C and relay D. Above each relay there is a yellow LED. Light indicates that the corresponding relay is ON and the output contact closed. The enclosure classification is IP 65 (Nema 4X).

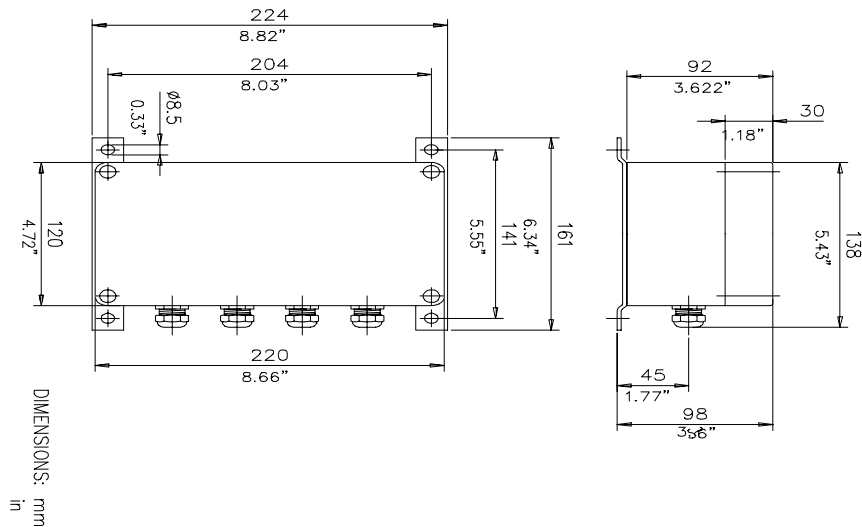

Figure 9.01 Relay unit PR-7080, dimensions.

WASH CONTROL RELAY UNIT-WR (2 RELAYS)

The Wash control Relay unit -WR contains 2 relays (Figure 9.02) from left to right: Relay A and Relay B. Next to each relay there is a yellow LED. Light indicates that the corresponding relay is ON and the output contact is closed. The enclosure classification is IP66 (Nema 4X).

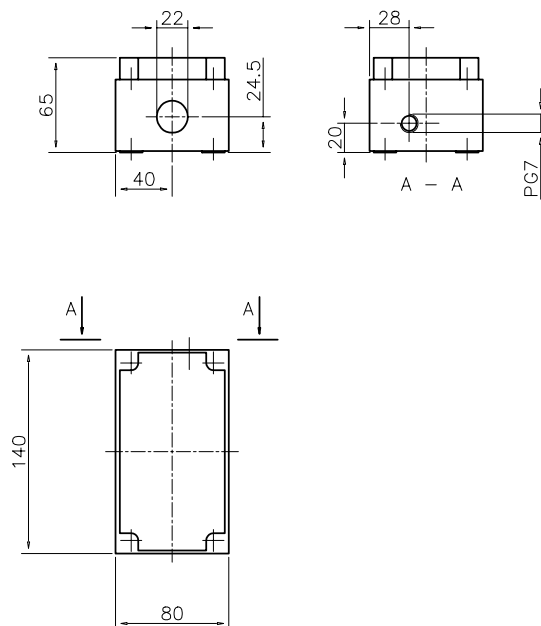

Figure 9.02 Wash control Relay unit -WR.

CABLE FITTINGS:

The cable fittings are delivered as one of two alternatives:

US: ½ NPT-TYPE ST-1 conduit hubs: 4 pcs; PR-7080, 1 pc; -WR

European: BF11/PG11 cable glands: 4 pcs; PR-7080, 2 pcs; -WR

Note: Seal all unused fittings with blind washers.

Each relay has one switch contact, for max 250 V AC, max 3 A. The Relay units have also two monitoring functions with two LEDs.

- a. The green LED L5 is lit, if the regulated 5 V supply to the processor is within limits 4.7 - 5.4 V and the processor operates correctly. Note that the 24 V supply from the serial bus has to be checked with a Volt-meter.
- b. The red LED L6 is lit, if correct serial data are missing (but the processor operates correctly).

Both checks have to be OK, otherwise all relays will go into OFF state.

9.1. CONNECTIONS

The Relay Card is connected to the serial bus for PR-7080 and to the plug connector P2 on the power supply card for wash control relay unit -WR, see Figure 3.63. The relay contacts go to the connector strip, Figure 9.10.

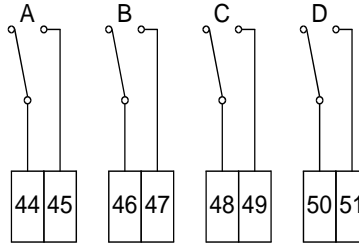

Figure 9.10 PR-7080 Relay output connections. In wash control relay unit-WR only A and B available.

9.2. RELAY CONFIGURATION

The relay functions of the Relay unit and the wash timer settings can be seen from the Indicating Transmitter. Press the key sequence Display/System configuration/Relay configuration or Wash times.

- The relay functions can be reprogrammed any time from the calibration menu:
- Program a relay by the following steps:
 - Press Calibrate/Parameters/Relays.
 - Select the relay (A,B,C,D) to be programmed. Note! Only Relays A and B are visible for Wash control relay unit-WR.
 - For built-in relays select Relay1 and Relay2.
 - Select the relay function
 0. Not defined
 1. Processor OK: The relay is ON if the processor is running
 2. Normal operation: The relay is ON if the diagnostic message is Normal operation.
 3. No malfunction: The relay is ON if the diagnostic message is Normal operation or Low conc/no sample.
 4. Low limit: Low alarm relay, relay is ON if value below limit.
 5. High limit: High alarm relay, relay is ON if value above limit.
 6. Preconditioning: A preconditioning relay, Figure 9.21. (Not used for built-in relays).
 7. Wash: A wash relay, Figure 9.21. (Not used for built-in relays).
 8. In divert control. Not used with PR-03
- After a Low limit/High limit decision, the display asks for the alarm source, alternatively:
 1. CONC %
 2. Standard RI(25 °C)
 3. TEMP °C
 4. TEMP °F
 5. TEST
 6. Sensor temperature
 7. Sensor humidity

Note. The alarm source can be changed by selecting relay function 9. for the alarm relay.

- When the source is decided, the alarm limit has to be entered. The default value of the limit is zero.

Note. To be complete, the specification of an alarm relay requires decision of High/Low, source and limit value.

To prevent the alarms to be too sensitive, an alarm delay in seconds can be set, common to all relays. The source value has to be out of limits during the whole delay time to activate the relay. The default value is ten seconds.

- If the Relay unit is used as a wash timer, the time settings (Figure 9.21) are entered after the sequence Calibrate/Parameters/Prism wash:
 1. Preconditioning time, s (10)
 2. Wash time, s (3)
 3. Recovery time, s (30)
 4. Wash interval, min (20)

The default values are in parenthesis. The output signal is locked during Recovery and Wash if not otherwise specified (Section 2.8, current output). See Section 8.2 for recommended time settings.

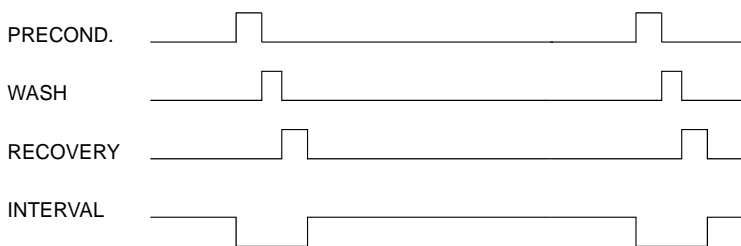

Figure 9.21 Prism wash sequence.

9.3. WASH LOGICS AND SMART WASH

Figure 9.21 describes the standard prism wash sequence Preconditioning/Wash/Recovery/Interval. In some cases the wash routine should be modified to better fit the application. The Wash decision logics (Figure 9.31) of K-Patents refractometer covers a wide range of options.

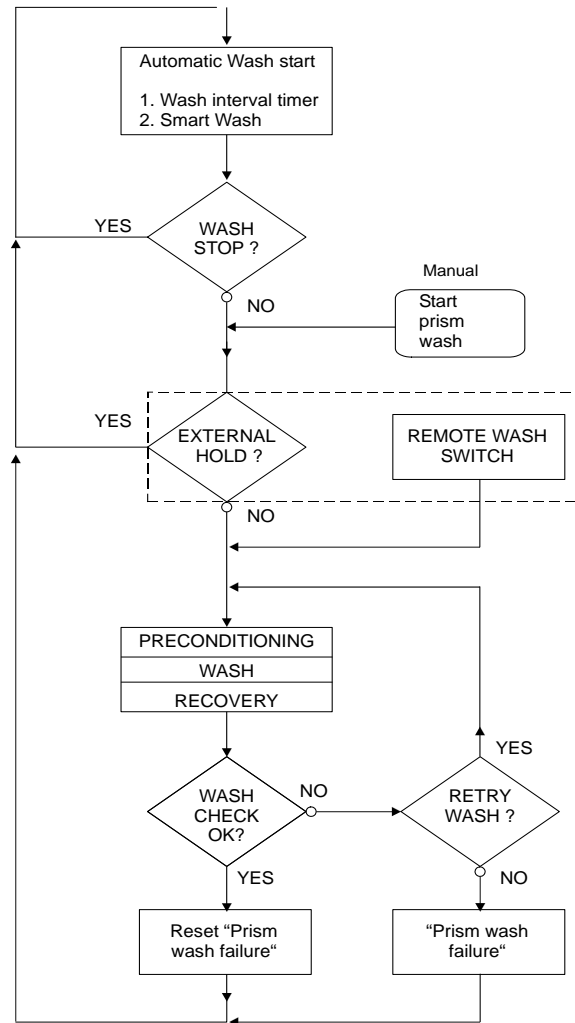

Figure 9.31 Wash decision logics.

AUTOMATIC WASH START:

1. The wash interval timer starts a wash at a preset interval after last wash, independently of how the last wash was initiated. If the wash interval is set to zero, the timer will not initiate a wash. How to set the wash times is described in Section 9.2.
2. The Smart wash starts the wash when the prism shows signs of being coated. An early indicator of beginning coating is that the Slope decreases. Slope is a measure of the sharpness of the optical image, Section 6.5. The settings are made at Calibrate/Parameters/Prism Wash/C Smart wash:

- Slope limit:

A wash is initiated when the Slope value goes below this limit. The Slope limit has to be set based on observations of slope values both at clean prism and at slight coating. When the slope limit is set to zero, this Smart wash function is inactive.

- Minimum time, 0...1440 min:

This parameter sets a limit to how often the Smart wash is allowed to start a wash. When this parameter is zero, the Smart wash function is inactive.

- Maximum Test:

This parameter should normally be set to zero. Then it will not influence the Smart wash function. It may be used for fine-tuning: The Smart wash will initiate Wash only if the Test value is below Maximum Test.

WASH STOP LOGICS:

1. The preconditioning and wash relays are not activated by automatic wash start under "Low conc/no sample", Section 6.30, as this indicates a clean prism in an empty process line.
2. Wash can be prevented when the process temperature is below a limit. The Wash stop function is used to prevent steam wash when the process pipe is empty or when the process is stopped. To activate the "wash stop" key sequence Calibrate/Parameters/1. Prism wash/Wash stop/1. Activate and set the temperature limit. The default value for wash stop is inactive. When the wash is not accepted the diagnostics message is "Wash stop/temp. limit", see Section 6.3.
3. Wash can also be prevented by an external contact closure, telling e.g. that the process pump has stopped. See Section 2.8, paragraph 3.3.

MANUAL WASH:

Wash can be initiated from the key A "Start prism wash". This manual wash over-rides the wash stop logics.

REMOTE WASH START/EXTERNAL HOLD:

This input switch function is described in Section 2.8, paragraph 3.2. It is useful for an intermittent process: The prism is washed when the process stops and again when it starts. Between those two washes the output signal is on Hold.

During Hold, the wash cannot be initiated, neither automatically nor manually.

WASH CHECK:

This function can be defined from the prism wash menu, Calibrate/Parameters/Prism wash. A prism wash is accepted if one of the two conditions are satisfied:

- a. TEST exceeds "TEST limit"
- b. TEST increases more than "TEST difference"

The default values of "TEST limit" and "TEST difference" are zero, which makes the Wash check inactive. If one of the conditions are set to zero, the other condition is valid alone. A typical case is "TEST limit" = 230, "TEST difference" = 0. The wash is accepted, if the Test value exceeds 230 during wash, and the Test difference condition is invalid.

If the wash is not accepted, the diagnostic message will be "Prism wash failure", Section 6.3. This message is reset from the keyboard "Reset" or by a successful wash. A "Wash retries" parameter can also be set for repeated wash actions if the wash check fails. The default value is zero.

10. ACCESSORY UNITS

10.1. EXTERNAL OUTPUT UNIT PR-7090

The K-Patents Sanitary Refractometer can be provided with a separate current output unit to give e.g. a temperature mA signal.

Cable fittings:

The cable fittings are delivered as one of two alternatives:

US: ½ NPT-TYPE ST-1 conduit hubs

European: BF11/PG11 cable glands

Note: Seal all unused fittings with blind washers.

The dimensions are the same as for the Relay unit, see Figure 9.01.

The mA output specifications are the same as for the built-in mA output of the Indicating Transmitter, see Section 2.2.

Two monitoring LEDs are on the circuit card, Figure 10.10:

- The green LED L1 is lit if the processor on the card works correctly.
- The red LED L2 is lit if correct input data are missing.

Connections

The External output unit is connected to the serial bus, see Figure 3.63 and Figure 10.10. Note the 120 Ohm closing resistor in Figure 3.63.

The output mA signal is connected to the terminals 42+ and 43-, see Figure 10.10.

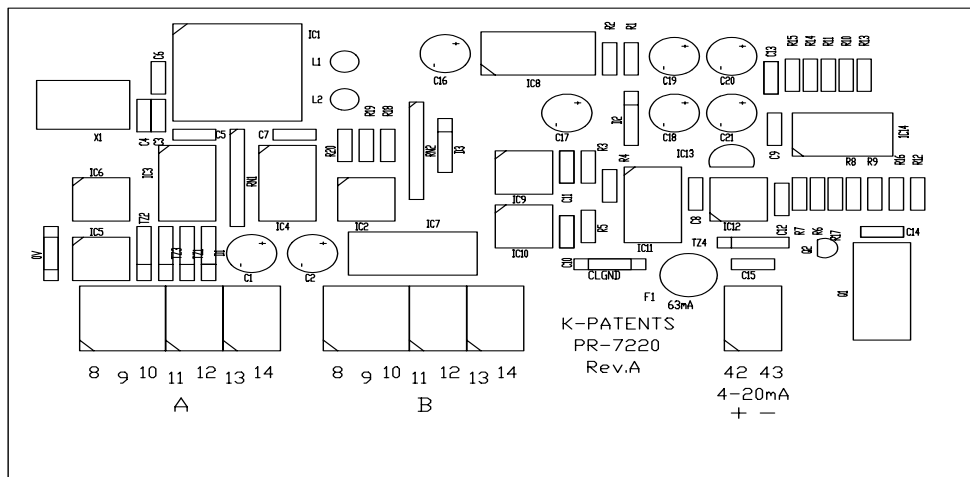

Figure 10.10. External output unit, component lay-out.

Configuration

To program the External output unit from the key-board of the Indicating Transmitter, start with the sequence Calibrate/Parameters/Output signals/External output.

1. Zero = measurement value corresponding to 4 mA.
2. Span = measurement value span corresponding to mA output span.
3. Hold function: Can be selected active or inactive.
4. Range: Select 4 - 20 mA or 0 - 20 mA
5. Source: Select one of following alternatives
 - Not defined
 - CONC (RI)
 - Standard RI (25 °C)
 - Temp °C
 - Temp °F

Example: For source °C, zero = 20, span = 80 the output signal 4 - 20 mA corresponds to 20 - 100 °C.

11. K-PATENTS SANITARY REFRACTOMETER CALIBRATION DATA REPORT

CUSTOMER: _____

ADDRESS: _____

REFRACTOMETER MODEL: _____ SERIAL NO. _____

SAMPLE DESCRIPTION (DISSOLVED MATERIALS): _____

SOLVENT: _____

LABORATORY METHOD: _____

DESIRED SCALE: OUTPUT 0-100 % (4-20 MA): _____ UNIT: _____

DATE: _____ SIGNATURE: _____

SAMPLE No.	SAMPLE CONC. LAB%	DISPLAY READINGS			SAMPLE DATE AND TIME	SIGN
		CONC%	TEST	TEMP. °C		