

**7773 Multipurpose
Electrode Mounting Assembly
Operation and Maintenance Manual**

70-82-25-34
Rev 0
2/97

Copyright, Notices, and Trademarks

Printed in U.S.A. – © Copyright 1997 by Honeywell Inc.

Revision 0.0 – 2/28/97

While this information is presented in good faith and believed to be accurate, Honeywell disclaims the implied warranties of merchantability and fitness for a particular purpose and makes no express warranties except as may be stated in its written agreement with and for its customer.

In no event is Honeywell liable to anyone for any indirect, special or consequential damages. The information and specifications in this document are subject to change without notice.

Honeywell
Industrial Automation and Control
Automation College
2820 West Kelton Lane
Phoenix, AZ 85023

(602) 313-5669

About This Document

Abstract

The purpose of this manual is to support the installation, operation and maintenance of the 7773 Multipurpose Electrode Mounting Assembly.

Revision Notes

The following list provides notes concerning all revisions of this document.

Rev. ID	Date	Notes
0	2/97	This document is the initial release of the Honeywell version of the 7773 Multipurpose Electrode Mounting Assembly Operation and Maintenance manual. This publication was originally released under the L&N systems as 177724, Rev. S5.

References

Honeywell Documents

The following list identifies all Honeywell documents that may be sources of reference for the material discussed in this publication.

Document Title	ID #	Binder Title	Binder ID #
----------------	------	--------------	-------------

Non-Honeywell Documents

The following list identifies select non-Honeywell documents that may be sources of reference for the material discussed in this publication.

Title	Author	Publisher	ID/ISDN #
-------	--------	-----------	-----------

Contacts

The following list identifies important contacts within Honeywell.

Organization	Telephone	Address
Honeywell TAC	1-800-423-8443 Voice	1100 Virginia Drive Fort Washington, PA 19034

Contents

1. INTRODUCTION	1
1.1 General	1
1.2 Description	1
2. SPECIFICATIONS AND MODEL SELECTION GUIDE	7
2.1 Specifications Common to All Models:.....	7
2.2 Model Selection Guide.....	8
Description	8
3. INSTALLATION	15
3.1 Overview	15
3.1.1 Assemble the Electrode Support	15
3.1.2 Mount Preamplifier 7773-1 , -4 , -5 , -6	16
3.1.3 Mount Preamplifier 7773-70, -80, Durafet® Type Electrodes	18
Precautions for Using Durafet® Electrodes in High Humidity and Condensation Areas	18
Maintaining The Silicone Grease Protected Electrodes	19
3.1.4 Mount the Terminal Assembly 7773-2 , -3	19
3.1.5 Final Assembly.....	19
Flow Type Assembly.....	20
Immersion Type Assembly.....	20
3.2 External Electrical Wiring	20
Preamplifier.....	20
Terminal Assembly	20
ORP Electrodes	20
Thermocouple.....	20
3.3 Mounting the Assembly	21
3.3.1 Immersion Assemblies	21
3.3.2 Flow Assemblies	21
4. MAINTENANCE	35
4.1 General	35
4.1.1 Standardizing.....	35
4.1.2 Disassembly.....	35
4.1.3 Cleaning.....	35
4.1.4 Care of Preamp Measuring Electrode Connector.....	36
4.1.5 Care of Ultrasonic Electrode Cleaner.....	36
4.2 Accessories.....	36
4.2.1 Accessories for 7773-1	36
4.2.2 Accessories for 7773-2 or -3	36
4.2.3 Accessories for 7773-70, -80	36

4.3 Replacement and Conversion Parts.....	37
Chemicals and Buffers	37
Conversion to Durafet® Electrodes	37
Maintenance Kit (except 7773-70, -80).....	37
Replacement Electrodes and Automatic Temperature Compensators.....	37

Tables

Table 2-1	7773 Electrode Mounting Specifications for Model Numbers 7773- -1 through 7773- -7.....	7
Table 3-1	Suggested Arrangements for Various Applications	15
Table 3-2	Connection Diagrams	16
Table 4-1	Replacement Electrodes and Automatic Temperature Compensators	37

Figures

Figure 1-1	7773 Electrode Mounting Assembly. (A) Immersion Mounting, (B) Electrode and Preamplifier Mounting, (C) Durafet® Measuring Electrode and Separately Mounted Reference Electrode, (D) Electrode Mounting with Preamplifier and Ultrasonic Cleaner, (E) Durafet® Electrode with Preamplifier	3
Figure 1-2	Complete Assembly for 7773 Electrode Mounting without Durafet®.....	4
Figure 1-3	Complete Assembly for 7773 Electrode Mounting with Durafet®	5
Figure 3-1	Suggested Mounting Arrangements.....	22
Figure 3-2	Drawing No. B-1577-260-B - Suggested Component Arrangement for 7773 Mounting Assembly (Immersion Type)	23
Figure 3-3	Drawing No. B-1577-260-E - Suggested Component Arrangement for 7773 Mounting Assembly (Flow Type)	24
Figure 3-4	Drawing No. B-1577-260-G - Suggested Component Arrangement for 7773 Mounting Assembly with no Preamplifier (Immersion Type) for Redox Measurement.....	25
Figure 3-5	Drawing No. B-1577-260-K - Suggested Component Arrangement for 7773 Electrode Mounting Assembly (Flow Thru or Immersion Type) with Internal Preamplifier	26
Figure 3-6	Drawing No. B-227-1-1 - Suggested Component Arrangement for 7773 Durafet® Electrode Mounting Assembly (Flow Type).....	27
Figure 3-7	Drawing No. B-227-1-2 - Suggested Component Arrangement for 7773 Durafet® Electrode Mounting Assembly (Immersion Type)	28
Figure 3-8	Drawing No. D-DIM-1577-260 - Outline and Mounting Dimensions of 7773 Electrode Mounting Assembly.....	29
Figure 3-9	Drawing No. D-DIM-227-1 - Outline and Mounting Dimensions of 7773 Electrode Mounting Assembly	30
Figure 3-10	Drawing No. B-10-081606-5 - Installation Diagram for pH Electrode Mounting Assembly 7773-6- and 7773-6.....	31
Figure 3-11	Drawing No. A-ID-081606-10 - ORP Electrode Connections to 7773-6- and 7773-6	31
Figure 3-12	Drawing No. A-ID-081606-12 - pH Electrode Connections for 7773-1 , 4 , 5 , and 7779-3,5 Electrode Mounting Assembly	32
Figure 3-13	Drawing No. ID-081606-13 - ORP Electrode Connections for 7773-30 and 7779-4 Electrode Mounting Assembly.....	32
Figure 3-14	Drawing No. A-ID-081606-15 - ORP Connections for 7773-10, 40 and 7779-3 Electrode Mounting Assembly with Preamplifier	33
Figure 3-15	Drawing No. ID-081606-16 - pH Electrode Connections for Direct Measurement Using a Junction Box	33
Figure 3-16	Drawing No. L-227 - Installation Diagram for Durafet® pH Electrode with 7773 Multipurpose Mounting Assembly	34

1. Introduction

1.1 General

The 7773 Multipurpose Electrode Mounting Assembly is designed for pH, ORP (oxidation reduction potential), or selective ion measurements. The electrode mountings are available in a number of basic forms (See Figure 1-1) with a selection of optional electrodes, measuring devices, and temperature compensators to fill a wide range of requirements.

For convenient installation or removal, the high impedance electrodes are terminated at a connector cap which is part of the preamp or terminal board. All other elements are connected to a terminal board located directly above them.

The Durafet® electrode and preamp combination utilize push-on cable connectors for ease in connection and replacement.

CAUTION

Do not allow liquids or other foreign matter to contact the Durafet cable connectors. Leave the protective cap in place on the circular connector whenever the cable is not installed on the electrode.

1.2 Description

As shown in Figure 1-1, the appearance and construction of these electrode mounts are similar, differing only in the type (flow or immersion) and the material of construction. Parts for the immersion mountings are interchangeable with the flow mountings and plastic parts are directly interchangeable with the corresponding stainless steel parts except that the threaded connecting ring and its mating part must be the same material. For example, a flow chamber of the flow type mounting can be replaced by an electrode guard to form an immersion unit or vice-versa.

The major components of the housing assembly, shown in Figures 1-2 and 1-3, consist of a plastic or stainless steel cover, plastic or stainless steel connecting ring and electrode support gland (plastic only). Flow type mountings include a stainless steel or plastic flow chamber; immersion assemblies include a plastic or stainless steel protector.

The metal parts are type 316 for corrosion resistance and are precision castings to provide maximum strength from a minimum amount of weight and size.

The plastic units are molded of black glass-filled polypropylene or glass-filled Ryton (brown polyphenylene sulfide, PPS). They are resistant to chemical attack and have high temperature capabilities, mechanical strength and long term stability. They contain a black ultraviolet light absorber to insure no deterioration when exposed to sunlight. Glass fibers provide strength and dimensional stability.

The electrode support part performs a primary function in the assembly. The same part is used for all mounting. It contains the electrode retainer which holds the electrodes in place when the unit operates under pressure and provides a mounting base for either the electrode preamplifier or a terminal assembly.

Three holes with O-ring seats and threads for compression nuts provide the mounting arrangement for the measuring electrode, reference electrode and either automatic temperature compensator for pH measurements or a plug if a hole is unused. An unfilled hole exists when measurements are made with a Meridian Electrode, ORP electrode, or pH fixed temperature compensation. For Durafet® Electrodes

(except 31079250), two plugs are supplied to fill the unused holes. The 31079250 requires a separate reference electrode and therefore only one unfilled hole is plugged.

Special dual O-rings are used under compression to form leak-proof seals between the electrodes and the electrode support. The O-ring material is low compression set, high resilience Viton A[®] which provides good sealing and excellent resistance. Its characteristics hold the O-ring in the proper position during compression. Optional EPM or Kalrez O-rings are available, see Figures 1-2 and 1-3. Through this arrangement, it is possible to effectively seal electrodes having different diameters in the electrode support gland, simultaneously allowing easy removal for servicing.

The plastic O-ring washers provide a bearing surface between the O-rings and compression nut to insure against adverse distortion of the O-rings during compression. The washers are made of a low-friction polypropylene.

Two large O-rings mounted in grooves on the outside diameter of the electrode support gland form seals with the machined surface in the cover and the flow chamber. In the case of the immersion assembly, no seal is required with the open electrode protector; the O-ring functions only as a retainer to aid in-assembly. These O-rings are special soft Viton A (or optional EPM or Kalrez) to aid in the assembly and disassembly of the gland from its mating parts and to resist chemical attack. Slots on the upper and lower surface of the flange on the support gland provide access for a screwdriver to further aid disassembly.

Functionally, the cover and support gland assembly form an enclosure for the preamp and for electrode terminations. They seal and protect against process entry, physical damage, and effects of moisture or other adverse ambient conditions.

The connecting ring holds upper and lower assembly parts together so that their inner surfaces seal against the corresponding O-ring on the electrode support gland. When removing a flow chamber, pressure is automatically released before the threads of this ring disengage.

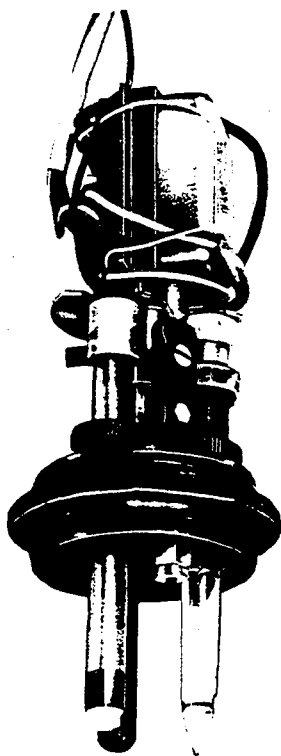

7773 IMMERSION MOUNTING ASSEMBLY

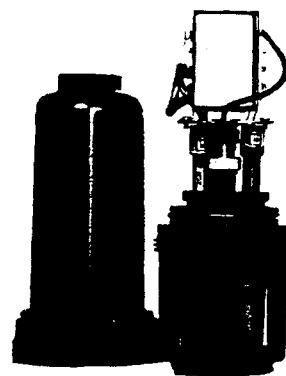

7773 Electrode and Preamp Mounting



Assembly with Durafet® Electrode mounted.

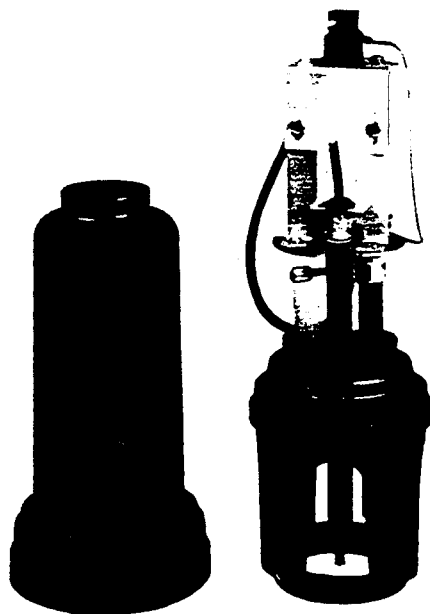

7773-7□ Durafet® Electrode and Preamp Option .

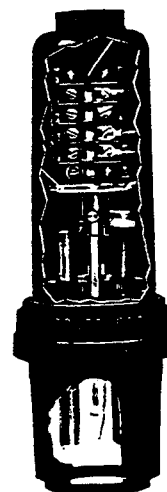

7773 Electrode Mounting with preamplifier and Ultrasonic Cleaner. The Ultrasonic Cleaner cannot be used with Durafet® Electrodes.



Figure 1-1 7773 Electrode Mounting Assembly. (A) Immersion Mounting, (B) Electrode and Preamp Mounting, (C) Durafet® Measuring Electrode and Separately Mounted Reference Electrode, (D) Electrode Mounting with Preamp and Ultrasonic Cleaner, (E) Durafet® Electrode with Preamp

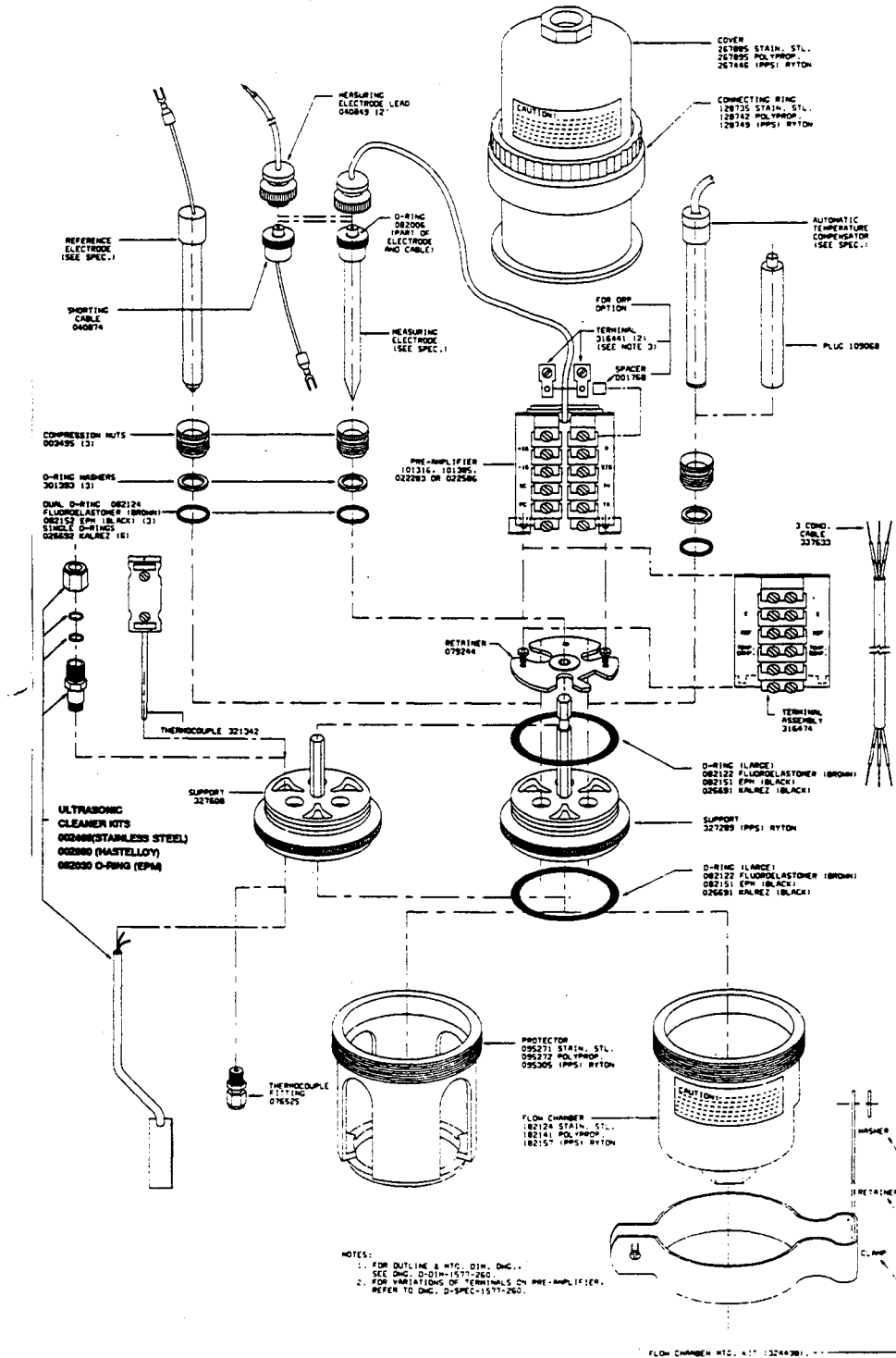

Figure 1-2 Complete Assembly for 7773 Electrode Mounting without Durafet®

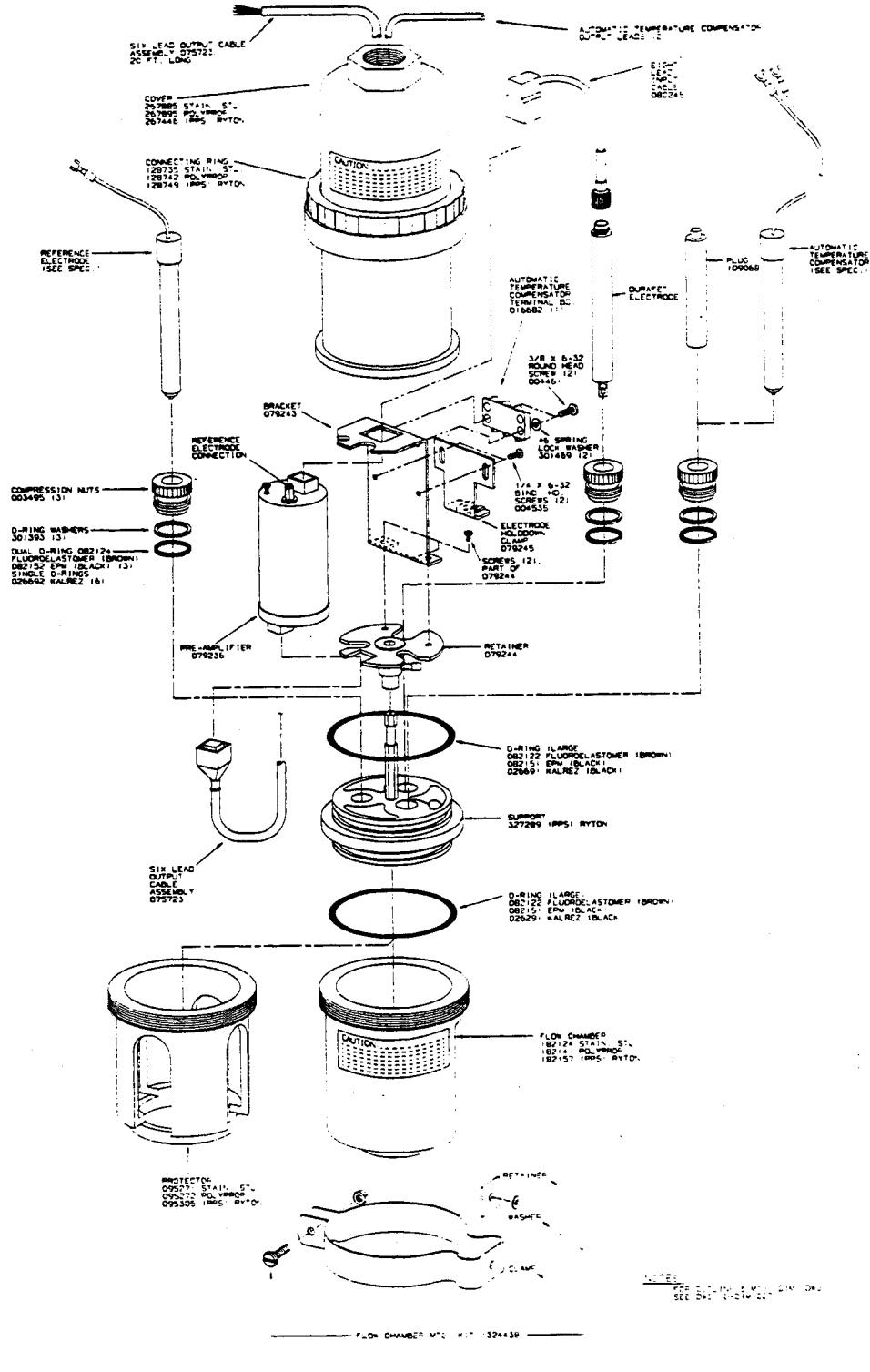

Figure 1-3 Complete Assembly for 7773 Electrode Mounting with Durafet®

2. Specifications and Model Selection Guide

2.1 Specifications Common to All Models:

Relative Humidity:	Can be used at 95% R.H.
Sample and/or Support	
Pipe Connections:	3/4" NPT, Female.
Dimensions:	4" O.D. X 11" L (102 x 279 mm).
O-Rings:	Viton A
O-Ring Washers:	Polypropylene — no in contact with sample.
Compression Nut:	Delrin — not in contact with sample.

Table 2-1 7773 Electrode Mounting Specifications for Model Numbers 7773- -1 through 7773- -7

Electrode Mounting	7773-xx-1	7773-xx-3	7773-xx-5	7773-xx-7
Use	For flow service in moderately pressurized lines or atmospheric discharges. All polypropylene with Ryton electrode support.	For flow service in high pressure lines. 316 SS chamber, ring and cover. Ryton electrode support.	For flow service in high pressure lines. Same as 7773- -3 except that cover is made of polypropylene.	For flow service in moderately pressurized lines or atmospheric discharges. All-Ryton construction.
Maximum Pressure and Temperature ¹	110 psig (7.03 kg/cm ²) 60°C (140°F); 50 psig (3.51 kg/cm ²) 80°C (176°F)	150 psig (10.5 kg/cm ²), 80°C (176°F) 80 psig (5.6 kg/cm ²), 130°C (266°F)		75 psig (5.26 kg/cm ²), 80°C (176°F)
Weight	3 lb. (1.4 kg)	6 lb (2.7 kg)	5 lb (2.3 kg)	4 lb (1.9 kg)
Installation	324438 Mounting Kit supplied for wall or other than surface mounting.			
Sample Flow Rate	15 gpm (56.8 l/m) maximum. Lower flow rate for viscous solutions and abrasives. For high purity water, flow and pressure should be constant with flow rate less than 0.5 l/min.			
Electrode Mounting	7773-xx-2	7773-xx-4	7773-xx-6	
Use	For immersion service in open tanks or process vessels. Similar to 7773- -1 except for substitution of electrode protecting guard for the flow chamber	For immersion service in open tanks or process vessels. Similar to 7773- -3 except for substitution of electrode protecting guard for the flow chamber.	All Ryton construction.	
Maximum Pressure and Temperature ¹	100 psig (7.03 kg/cm ²) 60°C (140°F); 50 psig (3.51 kg/cm ²) 100°C (212°F)		100 psig (7.03 kg/cm ²), 80°C (176°F) 80 psig (5.6 kg/cm ²), 110°C (230°F)	
Weight	3 lb. (1.4 kg)	6 lb (2.7 kg)	4 lb (1.9 kg)	
Installation	Pipe support in tank; use plastic pipe, not supplied.	Pipe support in tank; use SS pipe, not supplied.	Pipe support in tank; use plastic pipe, not supplied.	
Immersion Depth	Up to 200 ft (61 m) with preamp. Up to 10 ft (3m) length of adapter cable without preamp.			

1 Maximum temperature and pressure limits when using Meredian Electrode: 100 psig (7.03 kg/cm²) at 60°C (140°F); 50 psig (3.5 kg/cm²) at 80°C (176°F); 30 psig (2.1 kg/cm²) at 100°C (212°F).

2 Conforms to A.P.I. and ASME Codes for 150 psig operation. 7773- -3 and -5 recommended for use in high purity water.

3 Do not use for high purity water (less than 5.0 micromhos).

2.2 Model Selection Guide

Description

Section 2.2 lists the model number with appropriate Tables 1 through 5, which completely describe the equipment according to the following:

	Table I	Table II	Table III	Table IV	Table V
0773 -	---	--	---	--	-'----

Table I specifies a unit with either an integrally mounted electrode preamplifier or terminal board for wiring to direct-measuring instruments which require no electrode-signal conditioning. Table II specifies type (flow-through or immersion) and material (stainless steel or plastic). Table III and IV specify electrodes and automatic temperature compensators for the type measurement and range and the final measuring instrument used. Table V specifies options.

KEY NUMBER

Selection Availability

Description	Selection	Availability
7773 Electrode Mounting	07773	

TABLE I

Instrument, Preamp (without ultrasonic cleaner)			
Instrument	Preamp		
Honeywell (L&N) Analog Instruments Except 7079 Transmitter	31101316 preamp module for glass electrodes	10	
All glass pH direct connection instruments including 7082-3_,-71 Analyzer and 7079-44 Transmitter. Includes 12 ft. coaxial cable (31040849) and 12 ft. 3- conductor cable (31337633).	None	20	
All ORP direct connection instruments including 7082-3_,-71 Analyzer and 7079-22 Transmitter (customer supplied 2-conductor cable - 8 pin terminal board in electrode assembly for cable connections).	None	30	
7082-4_,-76 Analyzer (used with Durafet electrodes only).	None	40	

7079-11 Transmitter	31022586 glass/ORP electrode preamp module	50	
All Honeywell (L&N) microprocessor based instruments for glass pH measurements. Also for ORP with 7084.	31022283 glass/ORP electrode preamp module	60	
All Honeywell (L&N) Instruments. Includes 5 inch electrode-to-preamp cable (31080245) and 20 ft. preamp-to-instrument cable (31075723).	31079236 Durafet preamp module	70	
Non-Honeywell (L&N) Instruments used with Durafet Electrodes	31079290 Durafet Interface Module - 120 VAC Power	80	
	31084755 Interface Module - 240 VAC Power	90	
	31075773 Interface Module - Battery Powered	95	
Instrument, Preamp (with ultrasonic cleaner)			
Instrument	Preamp		
Honeywell (L&N) Analog Instruments Except 7079 Transmitter	31101316 preamp module for glass electrodes	12	
All glass pH direct connection instruments including 7082-3_, -71 Analyzer and 7079-44 Transmitter. Includes 12 ft. coaxial cable (31040849) and 12 ft. 3- conductor cable (31337633).	None	22	
All ORP direct connection instruments including 7082-3_, -71 Analyzer and 7079-22 Transmitter (customer supplied 2-conductor cable - 8 pin terminal board in electrode assembly for cable connections).	None	32	
7079-11 Transmitter	31022586 glass/ORP electrode preamp module	52	
All Honeywell (L&N) microprocessor based instruments for glass pH measurements. Also for ORP with 7084.	31022283 glass/ORP electrode preamp module	62	

TABLE II

Mounting, Material of Construction			
Mounting	Material of Construction		
Immersion	Polypropylene	2	
	Ryton	6	
	316 Stainless Steel	4	
In-line (includes P/N 31324438 mounting kit)	Polypropylene	1	
	Ryton	7	
	316 Stainless Steel Flow Chamber w/polypropylene cover	5	
	316 Stainless Steel	3	

TABLE III

Electrode Options (Combination Electrodes)					
Electrode Type		Temp. Range	Part Number		
None				00	
Meridian - pH	Note 1	10 to 100°C	31117486	40	d
ORP (gold)	Note 1	-5 to 110°C	31020749	50	e
Meridian pH and ORP (gold)		10 to 100°C/ -5 to 110°C	31117486/ 31020749	59	f
ORP (platinum)	Note 1	40 to 110°C	31020751	60	c
Meridian pH and ORP (platinum)		10 to 100°C/ -5 to 110°C	31117486/ 31020751	69	f
Durafet		-10 to 110°C	31079220	70	g
Electrode Options (Separate Measuring/Reference)					
Measuring Electrode					
Reference Electrode	Electrode Type	Temp. Range	Part Number		
Slurry Filled/ Ryton Body (P/N 31117392)	Glass - pH	-5 to 40°C	31117389	01	d
	Glass - pH	10 to 80°C	31117390	02	d
	Glass - pH	40 to 110°C	31117391	03	d
	ORP (gold)	-5 to 110°C	31117419	04	e
	ORP (platinum)	-5 to 110°C	31117418	06	e
	Antimony - pH	5 to 75°C	31117399	07	h
	Durafet - pH	-10 to 110°C	31079250	08	g

Slurry Filled/ Glass Body (P/N 31117300)	Glass - pH	-5 to 40°C	31117389	11	d
	Glass - pH	10 to 80°C	31117390	12	d
	Glass - pH	40 to 110°C	31117391	13	d
	ORP (gold)	-5 to 110°C	31117419	14	e
	ORP (platinum)	-5 to 110°C	31117418	16	e
	Antimony - pH	5 to 75°C	31117399	17	h
	Durafet - pH	-10 to 110°C	31079250	18	g
Gel Filled/ Ryton Body (P/N 31117481)	Glass - pH	-5 to 40°C	31117389	21	d
	Glass - pH	10 to 80°C	31117390	22	d
	Glass - pH	40 to 110°C	31117391	23	d
	ORP (gold)	-5 to 110°C	31117419	24	e
	ORP (platinum)	-5 to 110°C	31117418	26	e
	Antimony - pH	5 to 75°C	31117399	27	h
	Durafet - pH	-10 to 110°C	31079250	28	g
Gel Filled/ Glass Body (P/N 31117484)	Glass - pH	-5 to 40°C	31117389	31	d
	Glass - pH	10 to 80°C	31117390	32	d
	Glass - pH	40 to 110°C	31117391	33	d
	ORP (gold)	-5 to 110°C	31117419	34	e
	ORP (platinum)	-5 to 110°C	31117418	36	e
	Antimony - pH	5 to 75°C	31117399	37	h
	Durafet - pH	-10 to 110°C	31079250	38	g
Gel Filled/ Ryton Body - Double Junction (P/N 31035832)	Glass - pH	-5 to 40°C	31117389	41	d
	Glass - pH	10 to 80°C	31117390	42	d
	Glass - pH	40 to 110°C	31117391	43	d
	ORP (gold)	-5 to 110°C	31117419	44	e
	ORP (platinum)	-5 to 110°C	31117418	46	e
	Antimony - pH	5 to 75°C	31117399	47	h
	Durafet - pH	-10 to 110°C	31079250	48	g

Flowing Junction Kit (P/N 71035974) including electrode (P/N 31008712)	Glass - pH	-5 to 40°C	31117389	61	d
	Glass - pH	10 to 80°C	31117390	62	d
	Glass - pH	40 to 110°C	31117391	63	d
	ORP (gold)	-5 to 110°C	31117419	64	e
	ORP (platinum)	-5 to 110°C	31117418	66	e
	Antimony - pH	5 to 75°C	31117399	67	h
	Durafet - pH	-10 to 110°C	31079250	68	g

TABLE IV

Selection

Automatic Temperature Compensators					
Material		Part Number			
None	Note 2			0	
Plug (P/N 31109068) for ATC hole for ORP measurements, Durafet electrode or fixed temperature compensation.				1	
Ryton		31152137		2	j
Glass		31152139		4	j
Ryton		31022289		5	k
Glass		31022291		6	k

TABLE V - OPTIONS

Tagging	None	0	
	Linen Customer I.D. Tag, limit to 3 lines, 22 spaces per line.	L	
	Stainless Steel Customer I.D. Tag, limit to 3 lines, 22 spaces per line.	S	
O-ring Material	Ethylene Propylene	30 1	
High Purity	Includes solution ground rod (31078214), terminal board (31316441), support (31327608), and supplemental directions (277768)	40 1	l
Water Option			

Durafet Cables	12' quick disconnect (31079227)	50 1	m	b
	20' quick disconnect (31079228)	50 2	m	
	30' quick disconnect (31086236)	50 3	m	
	40' quick disconnect (31086237)	50 4	m	
	50' quick disconnect (31086238)	50 5	m	

Note 1: Also includes (1) 31109068 plug for support holes.

Note 2: The support bracket has three holes in it that must be filled; depending on the selection of electrodes and/or ATC options another plug may be needed. If required, make selection "1" in Table IV.

RESTRICTIONS

Restriction Letter b d e f g h j k l m	Available Only With		Not Available With	
	Table	Selection	Table	Selection
	Select only one option from this group.			
			l	30, 32, 40, 70, 80 90, 95
	l	30, 32, 60, 62		
		20, 22, 60, 62 (microprocessor units only)		
	l	40, 70, 80, 90, 95		
	l	20, 60 (microprocessor units only)		
	l	10, 12, 20, 22, 30, 32 50, 52 (analog units only)		
	l	20, 22, 40, 60, 62, 70 (microprocessor units only)		
	l	60		
	l	40, 80, 90, 95		

Series 7773 Accessories & Spare Parts

Note: For replacement electrodes see Replacement Electrodes Price List, Page RE-1 & 2.

Description	Part Number
Directions	177724
Waterproof Junction Box for 6-conductor cable	31316260
Cable - 2 Conductor for ORP connections to instrument (18 gage, PVC, Belden 9740)	31833070
Cable-TC leadwire solid conductors, overall insulation glass braid silicone impregnated	850044
Cable-12 ft., 3-conductor for connection from terminal board (31316464) to preamp	31337633
Cable grip-for preamp-to-instrument cables (3/4" NPT connection and 0.25" grommet hole)	31074354
Cable grip-Durafet cables only (3/4" NPT connection and 0.125" grommet hole)	31084760
Stainless steel mounting bushing	31367013
Cable-6 conductor for connection between preamp and instrument	834023
Cable-2 conductor for ATC connection between junction box and instrument	31835002
Shorting cable for ORP or checking preamp	31040874
Maintenance Kit for 117389 measuring electrode (-5 to 40°C)	31324441
Maintenance Kit for 117390 measuring electrode (10 to 80°C)*	31324442
Maintenance Kit for 117391 measuring electrode (40 to 110°C)*	31324443
Maintenance Kit for 117486 measuring electrode (10 to 100°C)*	31008473
Maintenance Kit for Durafet electrodes **	31079188
Silicone grease tube	31090011
Resistor (721.5 @ 25°C) for fixed temperature compensation with analog instruments	233026
Preamp for withdrawn analog instruments and direct input Speedomax recorders	31101316
Preamp for 7079-11 transmitter	31022586
Preamp for microprocessor based instruments	31022283
Durafet retrofit kit - includes hardware, cables and preamp to convert existing glass pH mounting to Durafet. Order Durafet electrode (and plug, if needed) separately.	31084741

* Kit includes two spare electrodes.

** Kit does not include spare electrodes, order spare electrodes separately.

3. Installation

3.1 Overview

Refer to Figures 1-2 and 1-3 to identify and check component parts as removed from the package. Refer to Table 3-1 for suggested component arrangements and associated drawings located at the end of this section.

CAUTION

The support pipe connection to the upper housing must be leak-proof.

A tube of white pipe sealant (Loctite 92-14, Honeywell Part 31083053) is supplied for use on these threads. Do not use a wrench if the housing is plastic. Use of the pipe sealant permits a leak-proof connection without the use of a wrench. Carefully cover the support-pipe-threads and sample-pipe-threads (flow chamber only) with the pipe sealant, then firmly hand-tighten the pipe connection if the housing or the pipe is plastic.

Table 3-1 Suggested Arrangements for Various Applications

Measurement	Type of Mounting	Component Arrangement Drawing and Figure No.
pH	7773-1 Immersion Type	B-1577-260-B, Figure 3-2
pH	7773-10, -40, -50 or -60 Flow Type	B-1577-260-E, Figure 3-3
ORP	7773-3 Immersion Type	B-1577-260-G, Figure 3-4
pH	7773-4[] or 7773-6 Flow or Immersion Type	B-1577-260-K, Figure 3-5
pH	7773-70 Flow Type	B-227-1-1, Figure 3-6
pH	7773-70 Immersion Type	B-227-1-2, Figure 3-7

3.1.1 Assemble the Electrode Support

ATTENTION

If the mounting is 7773-xx-2 or 7773-xx-2, the electrode support gland is furnished in Ultrasonic Electrode Cleaner Kits 002466 or 020990. Follow the procedures in Manual 70-82-25-43 for ultrasonic transducer installation.

If Table V specifies 401, for high purity water measurements, install the solution ground rod per Manual Supplement 70-82-25-58.

1. Apply a very thin film of translucent silicone grease--not pipe sealant--to all O-ring surfaces. Mount the large O-rings in the grooves of the support. Place the three dual O-rings in seats provided at the

bottom of the three threaded holes, and place the three translucent polypropylene washers over the O-rings.

2. Mount the three compression nuts in place, but do not tighten, the O-rings must not be compressed at this time.
3. Slowly insert the compensator into one of the holes, feeding it through the O-rings. Position it in the support gland so that its top is located in the same plane as the lower shoulder of the undercut in the hex rod.
4. Tighten the compression nut until it bottoms and resistance to moving the compensator in the O-ring is apparent. If a temperature compensator is not used, follow this procedure with the plug.
5. Remove the reference electrode from its package, and read the directions sheet. Remove the rubber protector from the tip, wash off any excess salt with tap water, and dry with a paper towel. Do not allow grease to come in contact with the porous plug.
6. Install the electrode as in Steps 3 and 4. Replace the rubber protector on the reference electrode until ready to use the mounting. If a reference electrode is not used, follow this procedure with a plug.
7. Remove the measuring electrode from its package. The pH measuring electrode is glass and requires care in handling. Read the electrode's directions before installing it.

CAUTION

Do not allow grease to coat glass membrane or metal tip. This will cause the electrode to become insensitive and malfunction.

8. Mount the measuring electrode in the remaining hole in accordance with Steps 3 and 4. pH electrodes with a connector cap must be positioned with the cap shouldered against the compression nut.
9. Mount the preamp or terminal assembly to the retainer and position it on the retainer so that the eight terminals face in the same directions as the setscrew located below the plate.

3.1.2 Mount Preamp 7773-1□, -4□, -5□, -6□

When a preamp is used, follow the procedures listed below. Electrode system connections are made per diagrams listed in Table 3-2 and located at the end of this section.

1. If the measuring electrode has the connector cap, loop the wire from the preamplifier over the top and mount the lead on the electrode. Do not over-tighten.
2. Mount the preamplifier retainer assembly on the hex stud of the support.
3. Orient the retainer in a position so that the setscrew is between the reference electrode and the automatic temperature compensator. The measuring electrode will be behind the terminal board.
4. Tighten the setscrew into the undercut on the stud.
5. Pull the sensors up to where their caps contact the retainer.
6. Place leads in slots and tighten compression nut as tight as possible by hand.
7. If the measuring electrode is ORP, attach the lead from the preamplifier to the shorting cable (040874). Attach the spade lug of the shorting cable in accordance with the applicable wiring diagram.

Table 3-2 Connection Diagrams

Model Number	Diagram and Figure No.
7773-10-□-□4	A-ID-081606-15, Figure 3-14
7773-10-□-□6	A-ID-081606-15, Figure 3-14
7773-10-□-50	A-ID-081606-15, Figure 3-14
7773-10-□-60	A-ID-081606-15, Figure 3-14
7773-1-□-□□ except as listed above	A-ID-081606-12, Figure 3-12
7773-2□	A-ID-081606-16, Figure 3-15
7773-3□	A-ID-081606-13, Figure 3-13
7773-40-□-□4	A-ID-081606-15, Figure 3-14
7773-40-□-□6	A-ID-081606-15, Figure 3-14
7773-40-□-50	A-ID-081606-15, Figure 3-14
7773-40-□-60	A-ID-081606-15, Figure 3-14
7773-4-□-□□ except as listed above	A-ID-081606-12, Figure 3-12
7773-5	A-ID-081606-12, Figure 3-12
7773-6-□-□4	A-ID-081606-10, Figure 3-11
7773-6-□-□6	A-ID-081606-10, Figure 3-11
7773-6-□-50	A-ID-081606-10, Figure 3-11
7773-6-□-60	A-ID-081606-10, Figure 3-11
7773-60-□-□□-□-401	B-ID-081606-18*
7773-6-□-□□ except as listed above	B-ID-081606-5, Figure 3-10
7773-70-□-□□-□	B-ID-227-6-1, Figure 3-16
7773-80-□-□□-□-501 to 505	**
7773-90-□-□□-□-501 to -505	See manual 70-82-25-13
7773-95-□-□□-□-501 to -505	See manual 70-82-25-65

*See Manual 70-82-25-58

**See Manual 70-82-25-13

3.1.3 Mount Preamplifier 7773-70, -80, Durafet® Type Electrodes

When an 31079236 Durafet® preamp is used (Table I = 70), follow the procedures listed below. Electrode system connections are made in accordance with the diagrams listed in Table 3-2.

CAUTION

Do not allow liquids or other foreign matter to contact the Durafet® cable connectors. Leave the protective cap in place on the circular connector whenever the cable is not installed on the electrode.

1. Refer to Figure 1-3. Mount the preamp onto the bracket and retainer and secure with a single screw. If a separate automatic temperature compensator is used, also mount terminal board 31016682 to the bracket as shown.
2. Connect the 31080245 cable between the electrode and preamp input connection as shown. Connect the 31075723 Output Cable to the preamp output connection.
3. Mount the preamp-retainer assembly on the hex stud of the support.
4. Orient the assembly so that the electrode hold-down clamp captures the Durafet® cable around the black insulator near the electrode connection. Tighten the hold-down clamp screw. The gold-plated electrode connector must not contact any surround metal.
5. Tighten the retainer setscrew into the undercut on the stud.
6. If a separate reference electrode is used, connect its lead to the Reference Electrode Connection Stud located near the preamp input connection. Pull the reference electrode up to where its cap contacts the retainer.
7. Place leads in slots and tighten compression nuts as tight as possible by hand.

Precautions for Using Durafet® Electrodes in High Humidity and Condensation Areas

The Durafet® preamplifier is suitable as shipped for relative humidity conditions up to about 85-90%, non-condensing. If condensation occurs, water must be prevented from accumulating in the 6 and 8-pin connectors; otherwise, erratic performance and damage to the connectors may result.

For the Durafet® Connectors, use silicone grease to provide protection from condensation. Before applying silicon grease, be sure that the connectors are clean and dry. After treatment with silicone grease, it is important to keep foreign material out of the connectors. Please handle all treated parts with care.

Use Honeywell part 31090011, a 0.3-oz. tube of High Vacuum Silicone Grease. Dow Corning High Vacuum Silicon Grease or Dow Corning #4 Silicone Electrical Insulating Compound may also be used. To apply the silicone grease:

1. Hold the opened end of the silicone grease tube against the pins of one of the two male connectors of the preamp, and carefully squeeze enough grease in to the connector to slightly overfill it. Repeat the procedure for the second male connector, completely filling it.
2. Hold the tube of silicone grease tightly against one of the rectangular female cable connectors and squeeze grease through the small openings until it is forced out of the small slots in the sides of the connector body. Repeat the process over the rest of the face of the female connector. Initially, you will see gold-plated connector contacts through these slots. By filling these spaces with silicone grease, you will prevent the accumulation of condensed water in these spaces. Perform the same procedure on the second rectangular cable in the same manner. Do not apply grease to the circular connector. The circular electrode connection is gasketed to prevent water intrusion.

3. Firmly insert the cable connectors into their mates on the preamplifier can. Press firmly for full insertion and hold for several seconds to allow excess silicone grease and entrapped air to escape. Wipe off all excess grease from the external surfaces of the assembly.

Maintaining The Silicone Grease Protected Electrodes

1. When disconnected, the connectors that have been protected with silicone grease must be protected from dirt and dust. A small additional application of the grease is recommended before they are reconnected. If there is any uncertainty about cleanliness, we suggest that the connectors be thoroughly blown clean with compressed air or inert gas that is water and oil free. Then repeat the application of silicone grease as described in the section above.
2. When an 31079290 or 31084755 Durafet® preamp is used (Table I = 80 or 90), follow the same procedures as above except that electrical connections are made to the remotely mounted module. See Manual 70-82-25-13 for the 31079290 and 31084755 Industrial PreAmp Modules.
3. All electrode-system wires should be dressed and positioned so that they extend only far enough to permit connection. Position them as close to the center of the retainer as possible. No wire should extend beyond the outside diameter of the retainer.
4. Complete the assembly by lubricating the large O-rings with the silicone grease supplied.

3.1.4 Mount the Terminal Assembly 7773-2□, -3□

Mount the retainer assembly as described in Section 3.1.2. If the housing is stainless steel, tie the connector to the stud with tape or cord. The outer ring on the connector is at circuit-common potential and must not make contact with the cover.

When the terminal assembly is used, follow this procedure:

1. If the measuring electrode has a connector cap, and the adapter cable is used, first attach the adapter cable to the electrode and then mount the assembly on the hex stud. Connect to the terminal board as shown in the appropriate connection diagram listed in Table 3-2.
2. If a high-impedance measuring electrode (such as pH) has an integral lead, the retainer is positioned so that its slots are in line with the electrodes. The lead is pulled through to a junction box having low-loss insulators, or the terminal board of a direct-measuring instrument. Mounting and positioning are the same as described in Section 3.1.2, steps 2, 3, and 4.
3. If a low-impedance measuring electrode (e.g. ORP) is used, connect one electrode to terminal E and the other electrode to terminal REF. For an ORP electrode system in chrome and cyanide treatment, the metal element connects to the REF(+) terminal and the reference connects to E(-) terminal.
4. All electrode-system wires should be dressed and positioned so that they extend only far enough to permit connection. Position them as close to the center of the retainer as possible. No wire should extend beyond the outside diameter of the retainer.
5. Complete the assembly by lubricating the large O-rings with the silicone grease supplied.

3.1.5 Final Assembly

1. Insert the assembled electrode support into the cover.
2. Rotate the assembly as the insertion is made to curl the interconnecting leadwire. Make certain that none of the wires loop down over the edge of the retainer disc. This can result in damage to the wire insulation, and if the cover is metal it will cause electrical shorts. It will also force the retainer to the side, and should any of the metal parts on the retainer, which are all at circuit common potential, make contact with the metal cover, it will cause a grounding malfunction.
3. Press the support assembly into the cover until the flange of the support makes contact with the cover.

Standardization is fully described in the pH analyzer manual. If a standard buffer is used to standardize the electrode, place the electrode in a buffer at this time and perform the standardization procedure.

Flow Type Assembly

1. Mount the cover with electrodes in the flow chamber. To avoid electrode breakage, carefully align the electrodes with the opening of the flow chamber.
2. Slowly force the assembled cover into place. Do not allow the cover assembly to cock to one side as this may cause damage to the electrodes.
3. Screw the connecting ring to the flow chamber and tighten it hand tight. The cover and the flow chamber should now be held tightly against the flange of the electrode support assembly.

Immersion Type Assembly

1. Insert the assembled electrode support into the cover as described for the flow type.
2. Then mount the protector onto the electrode support by pressing it onto the O-ring.
3. Screw the connecting ring to the protector and tighten it hand-tight.

3.2 External Electrical Wiring

There is space in the cover for extra length of interconnecting wire, which is required to provide the slack necessary to remove the preamp or terminal assembly to the point where the connecting terminals are exposed. For wiring connections, see Table 3-2.

Preamplifier

The preamplifier, when specified, converts a high impedance signal to a high-level signal for transmission over long distances free from other electrical interferences without the use of special shielded cables. The circuitry of the preamp includes input filtering which provides high immunity to common mode "ground loop" or R.F. interferences. Measurements can be made in grounded or ungrounded solutions. The preamp provides an electrically-guarded circuit which reduces the effect of any insulation deterioration on the cap.

Terminal Assembly

The terminal assembly (if specified, i.e., 7773-2 or -3) used with an adapter cable permits use of this mounting with direct-measuring instruments. For distances greater than 10 feet, a junction box is required.

ORP Electrodes

ORP electrodes do not require an adapter cable if the measuring instrument operates directly from the electrodes and not from a preamp. If a preamp is used, terminate the electrode cable by means of the shorting cable supplied with the preamp. This is necessary to accommodate both positive and negative ORP potentials. Connection of the reference and measuring electrode leads may have to be interchanged to conform to the polarity of some ORP electrode outputs.

If a high-impedance measuring electrode has integral leadwire (no connector cap), it can be used with the 316529 Preamp Module or with direct-measuring type instruments. For the latter, connections must be made in a 31352107 Junction Box which has low-loss insulation terminals.

Thermocouple

The thermocouple head forms the connector assembly for the thermocouple extension leadwire. Use 24 gage iron-constantan extension wire which can be ordered from Honeywell by specifying 85001 and length required. Run the extension wire through the support pipe with the other cable and, by way of a pipe tee, to a suitable junction box. Remove the male plug from the head of the thermocouple and connect the

extension wire to the internal terminals, observing polarity. Connect the red wire (constantan) to the wider leg marked CON. Connect the black wire (iron) to the leg marked +.

3.3 Mounting the Assembly

3.3.1 Immersion Assemblies

Immersion assemblies with preamplifiers or direct measuring ORP instruments can be immersed to depths of 200 feet. Units requiring a junction box are limited to a maximum depth of 10 feet. The support pipe must be large enough to contain the interconnecting wire from the electrode housing assembly. When these leadwires are used, a 3/4 IPS pipe must not be heavier than Schedule 80. Larger pipes can be used, but they must be reduced to 3/4-inch pipe to connect the assembly.

To avoid cracking the plastic housing, use a plastic support pipe. For either metal or plastic pipe, cover the pipe threads with the Loctite pipe sealant supplied. If either housing or pipe are plastic, hand-tighten the connection. Do not use a wrench. Any metal pipe which is not attacked by the sample can be used as a support pipe for the stainless steel assembly.

The outline and dimension information is given on drawing D-DIM-1577-260 or D-DIM-227-1 listed in Table 3-1, as applicable. Note that a flexible section (hose, flexible conduit or open cable) is required to permit removal from the sample without disconnecting the wiring. Any convenient means can be used to mount the assembly provided it is secure and can be easily withdrawn for servicing. Four suggested mounting arrangements are illustrated in Figure 3-1.

The arrangement in Figure 3-1A permits quick removal. The approach having holes with a securing pin can be produced so that the external moveable pipe is long enough to allow the electrode assembly to clear the top of the tank without the moveable pipe being withdrawn from the pipe fastened to the tank wall. By placing a pin in a hole above the end of the fastened pipe, the assembly can be rotated clear of the tank for servicing.

Figure 3-1B is a practical approach which permits the location of the assembly into almost any part of an open tank. By removing one bolt or clamp and rotating on the other, the electrode assembly can be brought to the side of the tank for servicing.

Figure 3-1C incorporates the use of a flange for a closed vessel. If the vessel is pressurized, the support pipe can be welded to the flange or sealed in packing.

Figure 3-1D can be made up in many configurations. It is important that the support pipe be well secured when considerable strain is placed on the assembly due to a highly agitated or viscous sample.

3.3.2 Flow Assemblies

The flow assemblies are dimensionally the same as shown in D-DIM-1577-260 or D-DIM-227-1, as listed in Table 3-1. They are provided with 3/4 NPT female pipe connections for sample line connections and the electrical outlet connection. The assemblies can be supported by the connecting sample pipes or wall mounted by the flow chamber mounting kit provided. Allow a minimum of 8-inch clearance for removal of the cover. Plastic pipe is recommended for use with the plastic assembly, however, if metal pipe must be used, coat the threads well with the pipe sealant furnished and do not overtighten. With appropriate fittings, either hose or tubing can be used for sample lines.

Maximum sample flow rate is 15 gpm. If the sample has a viscosity greater than water or if it carries abrasives, the flow rate should be less than 5 gpm. For high purity water (less than 5-microhms), regulate the sample flow rate to less than 500 cc/min (0.13 gpm) and discharge to atmosphere.

The sample flow enters the assembly at the bottom and discharges through the side. Install valves in the inlet and outlet piping, with a bypass if necessary, to permit servicing without shutting down the process.

Electrical connections are made through a 3/4 NPT female connector in the cover. Hardware arrangements are shown in the appropriate drawing listed in Table 3-1

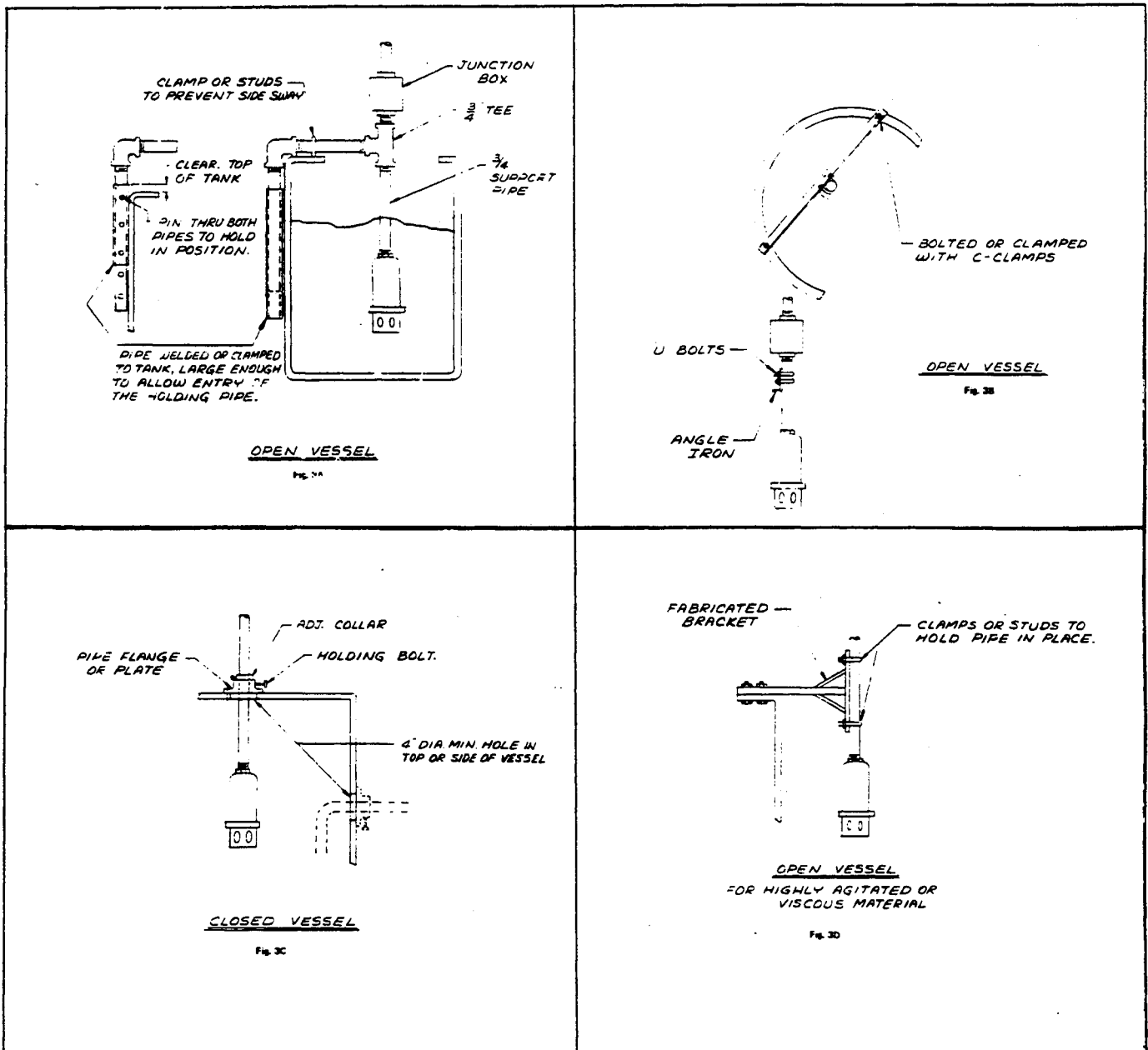

Figure 3-1 Suggested Mounting Arrangements

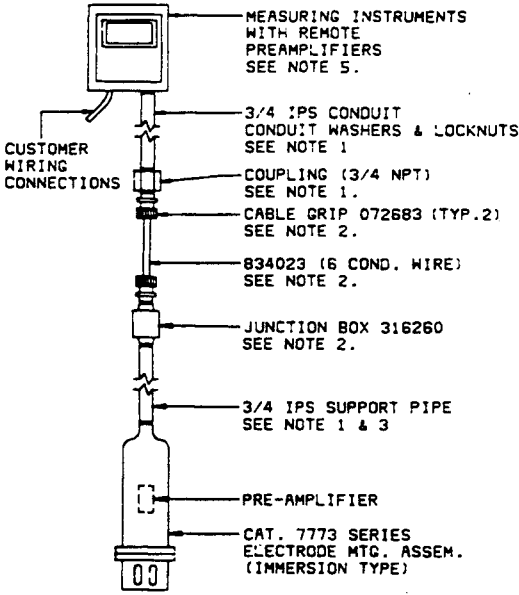

FIG. 1

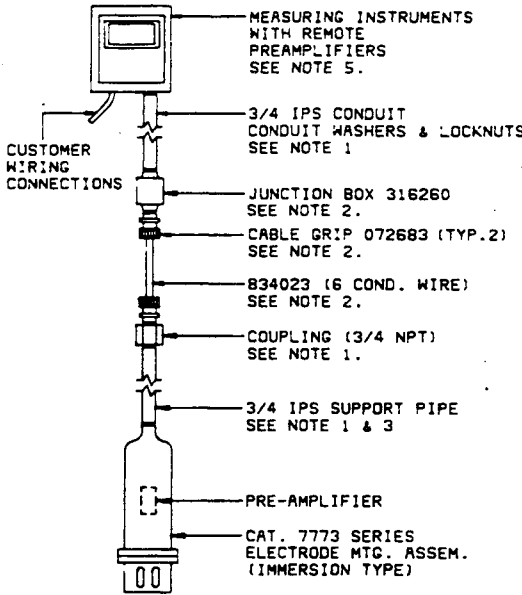

FIG. 2

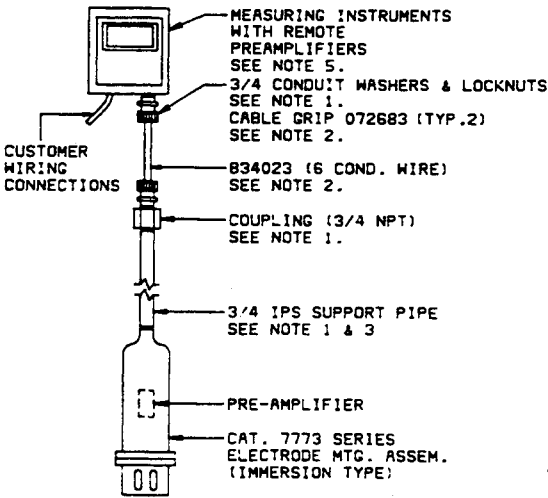

FIG. 3

CUSTOMER'S NOTES:

1. PARTS SUPPLIED BY CUSTOMER.
2. PARTS MAY BE OBTAINED ON L&N ORDER USING PART NO. SHOWN.
3. WHEN MOUNTING ASSEMBLY COVER IS STAINLESS STEEL USE STAINLESS STEEL PIPE.

WHEN MOUNTING ASSEMBLY COVER IS PLASTIC USE PLASTIC PIPE.
4. FOR INSTALLATION WIRING DIAGRAM, SEE SCHEMATICS IN DIRECTION BOOKS FOR ELECTRODE MTC. & MEAS. INSTRUMENT USED.
5. WHEN NEMA 4 RATING IS REQUIRED, CUSTOMER TO SUPPLY WATER TIGHT SEALS FOR ELECTRICAL INLETS TO MEAS. INSTRUMENT USED.

Figure 3-2 Drawing No. B-1577-260-B - Suggested Component Arrangement for 7773 Mounting Assembly (Immersion Type)

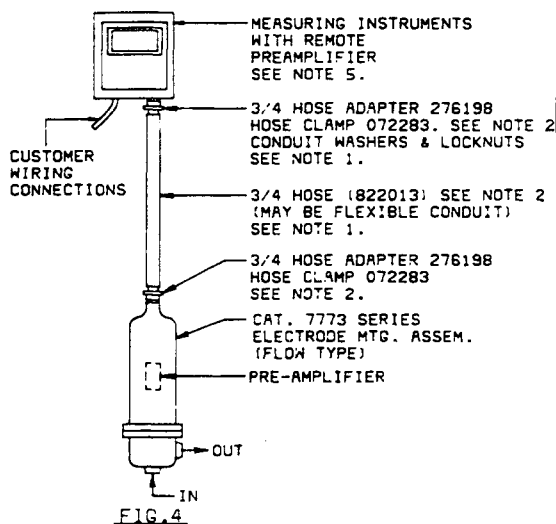
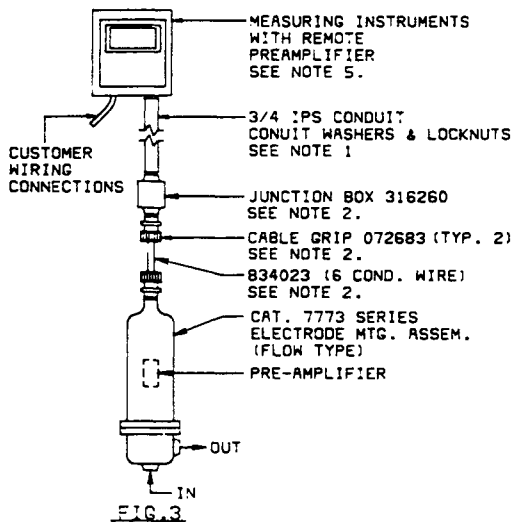
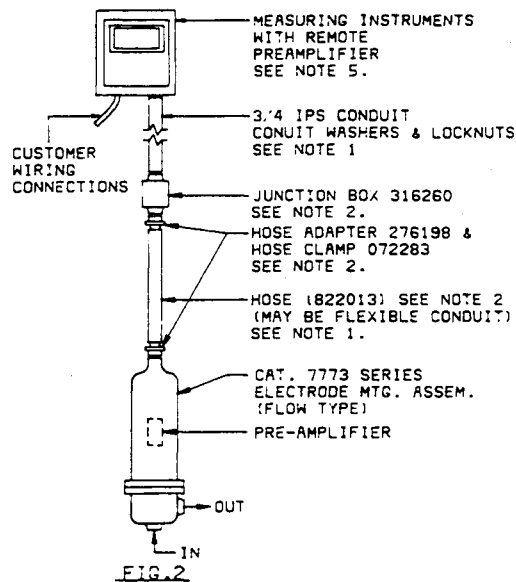
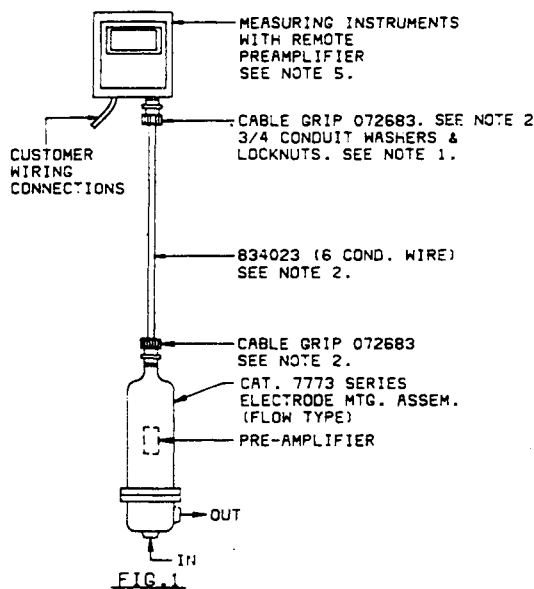

CUSTOMER'S NOTES:

1. PARTS SUPPLIED BY CUSTOMER.
2. PARTS MAY BE OBTAINED BY L&N ORDER USING PART NO. SHOWN.
3. WHEN MOUNTING ASSEMBLY COVER IS STAINLESS STEEL USE STAINLESS STEEL PIPE.
WHEN MOUNTING ASSEMBLY COVER IS PLASTIC USE PLASTIC PIPE.
4. FOR INSTALLATION WIRING DIAGRAM, SEE SCHEMATICS IN DIRECTION BOOKS FOR ELECTRODE MTG. & MEAS. INSTRUMENT USED.
5. WHEN NEMA 4 RATING IS REQUIRED, CUSTOMER TO SUPPLY WATER TIGHT SEALS FOR ELECTRICAL INLETS TO MEAS. INSTRUMENT USED.

Figure 3-3 Drawing No. B-1577-260-E - Suggested Component Arrangement for 7773 Mounting Assembly (Flow Type)

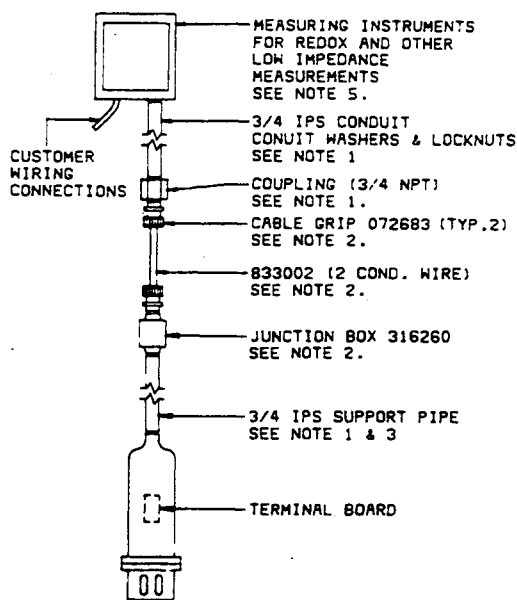

FIG. 1

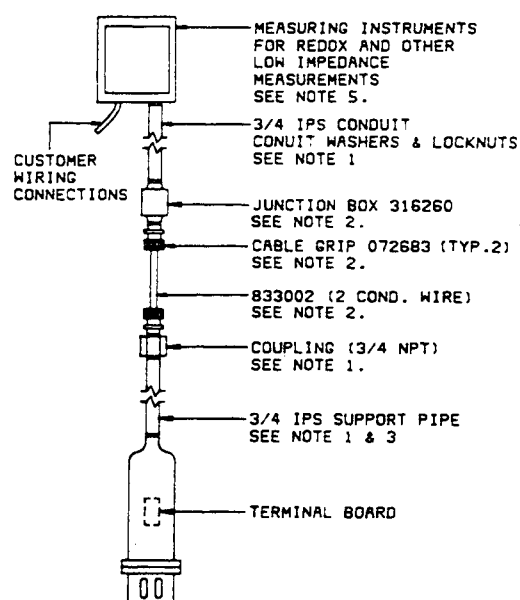

FIG. 2

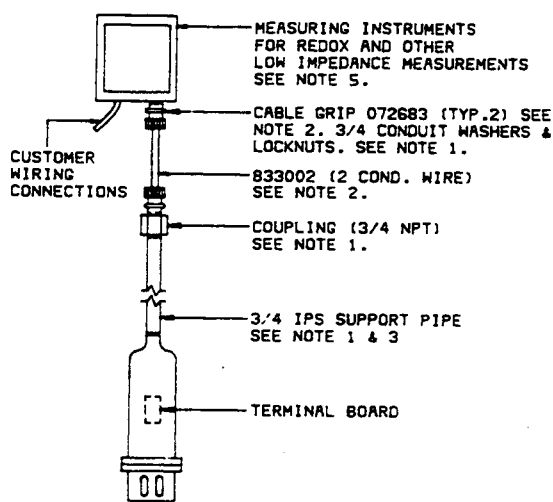

FIG. 3

CUSTOMER'S NOTES:

1. PARTS SUPPLIED BY CUSTOMER.
2. PARTS MAY BE OBTAINED ON L&N ORDER USING PART NO. SHOWN.
3. WHEN MOUNTING ASSEMBLY COVER IS STAINLESS STEEL USE STAINLESS STEEL PIPE.
WHEN MOUNTING ASSEMBLY COVER IS PLASTIC USE PLASTIC PIPE.
4. FOR INSTALLATION WIRING DIAGRAM, SEE SCHEMATICS IN DIRECTION BOOKS FOR ELECTRODE MTG. AND MEAS. INSTRUMENT USED.
5. WHEN NEMA 4 RATING IS REQUIRED, CUSTOMER TO SUPPLY WATER TIGHT SEALS FOR ELECTRICAL INLETS TO ANALYZER USED.
6. FOR SUGGESTED MTG. ARRANGEMENTS, SEE C-1577-260-F.

Figure 3-4 Drawing No. B-1577-260-G - Suggested Component Arrangement for 7773 Mounting Assembly with no Preampifier (Immersion Type) for Redox Measurement

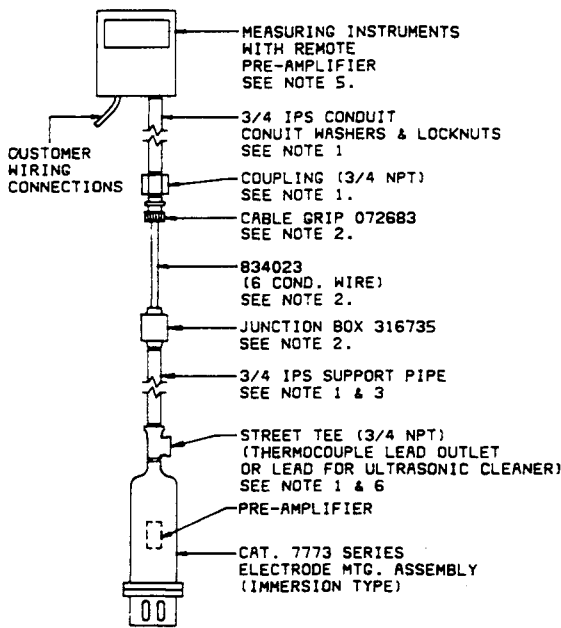

FIG. 1

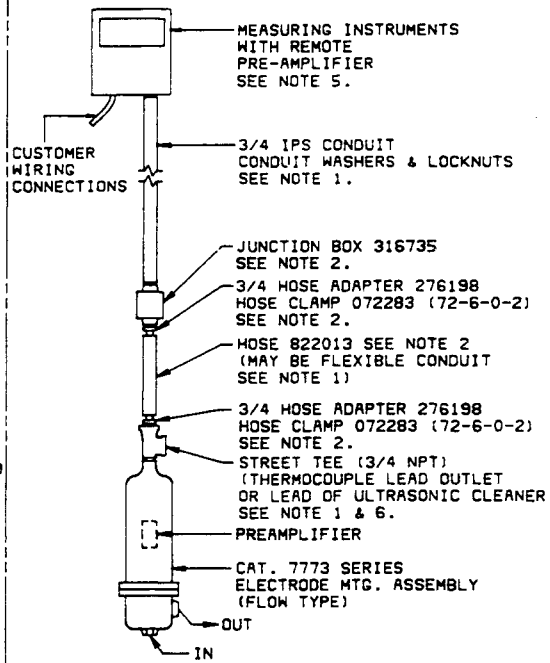

FIG. 2

CUSTOMER'S NOTES:

1. PARTS SUPPLIED BY CUSTOMER.
2. PARTS MAY BE OBTAINED ON L&N ORDER USING PART NO. SHOWN.
3. WHEN MOUNTING ASSEMBLY COVER IS STAINLESS STEEL USE STAINLESS STEEL PIPE.
WHEN MOUNTING ASSEMBLY COVER IS PLASTIC USE PLASTIC PIPE.
4. FOR INSTALLATION WIRING DIAGRAM, SEE SCHEMATICS IN DIRECTION BOOK FOR ELECTRODE MTC. & MEAS. INSTRUMENT USED.
5. WHEN NEMA 4 RATING IS REQUIRED, CUSTOMER TO SUPPLY WATER TIGHT SEALS FOR ELECTRICAL INLETS TO MEASURING INSTRUMENT USED.
6. LEAD FOR ULTRASONIC CLEANER SHOULD BE TEED-OFF AS CLOSE TO THE COVER AS IS PRACTICAL.

Figure 3-5 Drawing No. B-1577-260-K - Suggested Component Arrangement for 7773 Electrode Mounting Assembly (Flow Thru or Immersion Type) with Internal Pre-amplifier

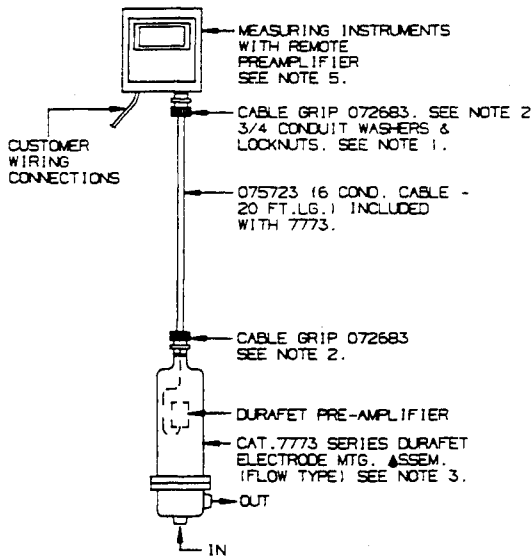

FIG. 1 PRE-AMP TO MEASURING INSTRUMENT SEPARATION 20 FT. OR LESS.

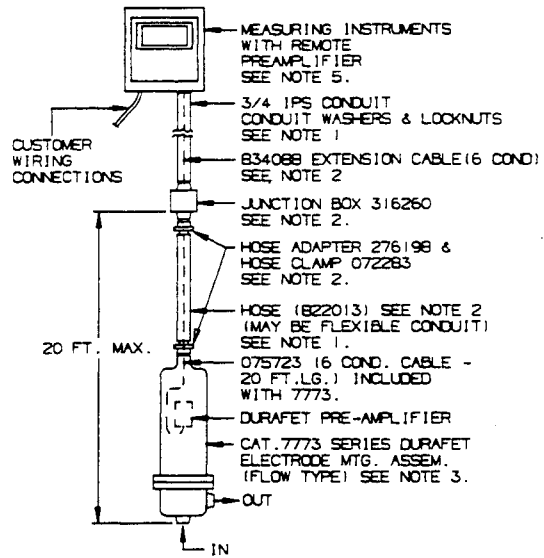

FIG. 2 PRE-AMP TO MEASURING INSTRUMENT SEPARATION GREATER THEN 20 FT.

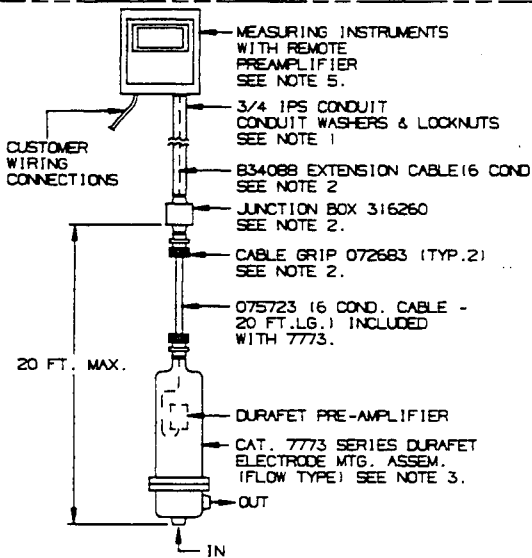

FIG. 3 PRE-AMP TO MEASURING INSTRUMENT SEPARATION GREATER THAN 20 FT.

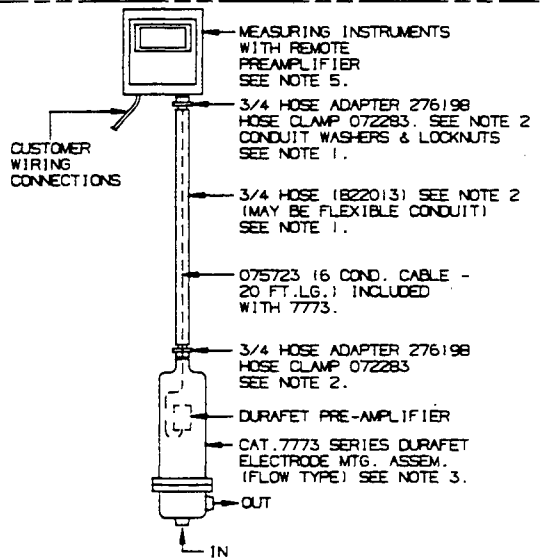

FIG. 4 PRE-AMP TO MEASURING INSTRUMENT SEPARATION 20 FT. OR LESS

CUSTOMER'S NOTES:

1. PARTS SUPPLIED BY CUSTOMER.
2. PARTS MAY BE OBTAINED FROM L&N. ORDER USING PART NO. SHOWN.
3. WHEN MOUNTING ASSEMBLY FLOW CHAMBER IS STAINLESS STEEL USE STAINLESS STEEL PIPE.
WHEN MOUNTING ASSEMBLY FLOW CHAMBER IS PLASTIC USE PLASTIC PIPE.
4. FOR INSTALLATION WIRING DIAGRAM, SEE SCHEMATICS IN DIRECTION BOOKS FOR ELECTRODE MOUNTING AND MEASURING INSTRUMENT USED.
5. WHEN NEMA 4 RATING IS REQUIRED, CUSTOMER TO SUPPLY WATER TIGHT SEALS FOR ELECTRICAL INLETS TO MEASURING INSTRUMENT USED.

Figure 3-6 Drawing No. B-227-1-1 - Suggested Component Arrangement for 7773 Durafet® Electrode Mounting Assembly (Flow Type)

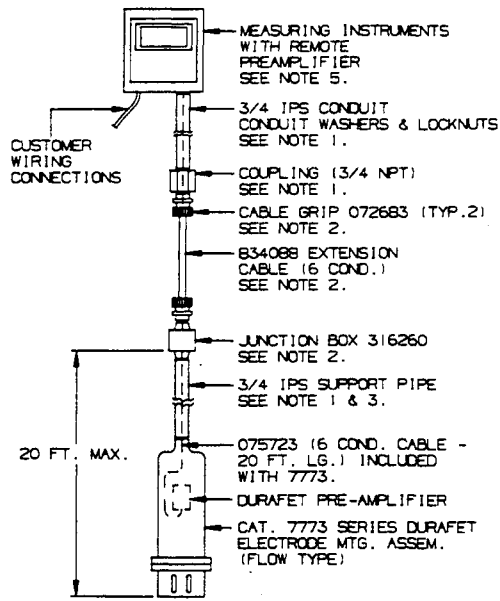

FIG. 1 PRE-AMP TO MEASURING INSTRUMENT SEPARATION GREATER THAN 20 FT.

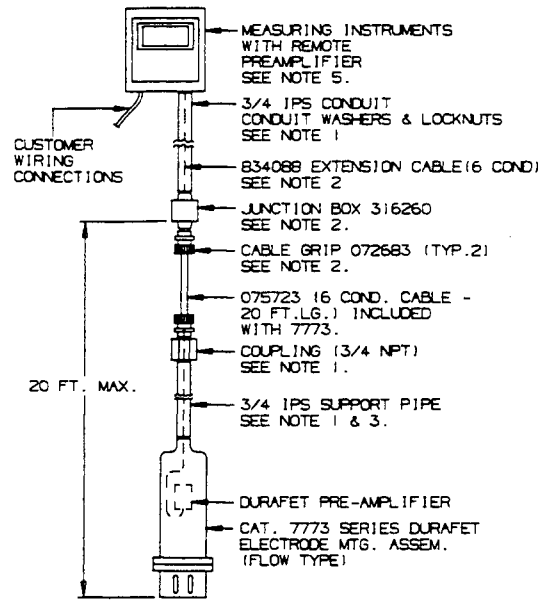

FIG. 2 PRE-AMP TO MEASURING INSTRUMENT SEPARATION GREATER THAN 20 FT.

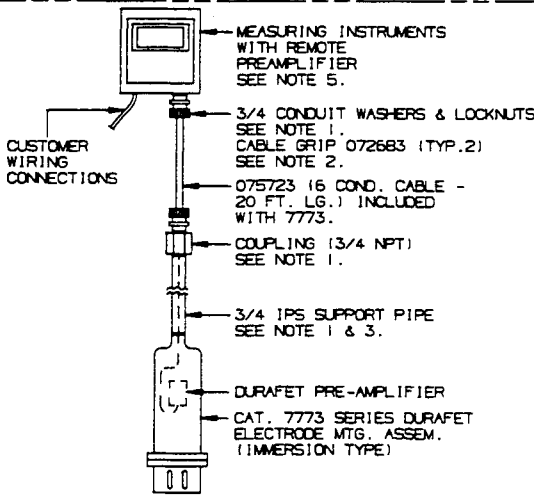

FIG. 3 PRE-AMP TO MEASURING INSTRUMENT SEPARATION 20 FT. OR LESS

CUSTOMER'S NOTES:

1. PARTS SUPPLIED BY CUSTOMER.
2. PARTS MAY BE OBTAINED FROM L&N. ORDER USING PART NO. SHOWN.
3. WHEN MOUNTING ASSEMBLY COVER IS STAINLESS STEEL USE STAINLESS STEEL PIPE.
WHEN MOUNTING ASSEMBLY COVER IS PLASTIC USE PLASTIC PIPE.
4. FOR INSTALLATION WIRING DIAGRAM, SEE SCHEMATICS IN DIRECTION BOOKS FOR ELECTRODE MOUNTING AND MEASURING INSTRUMENT USED.
5. WHEN NEMA 4 RATING IS REQUIRED, CUSTOMER TO SUPPLY WATER TIGHT SEALS FOR ELECTRICAL INLETS TO MEASURING INSTRUMENT USED.

Figure 3-7 Drawing No. B-227-1-2 - Suggested Component Arrangement for 7773 Durafet® Electrode Mounting Assembly (Immersion Type)

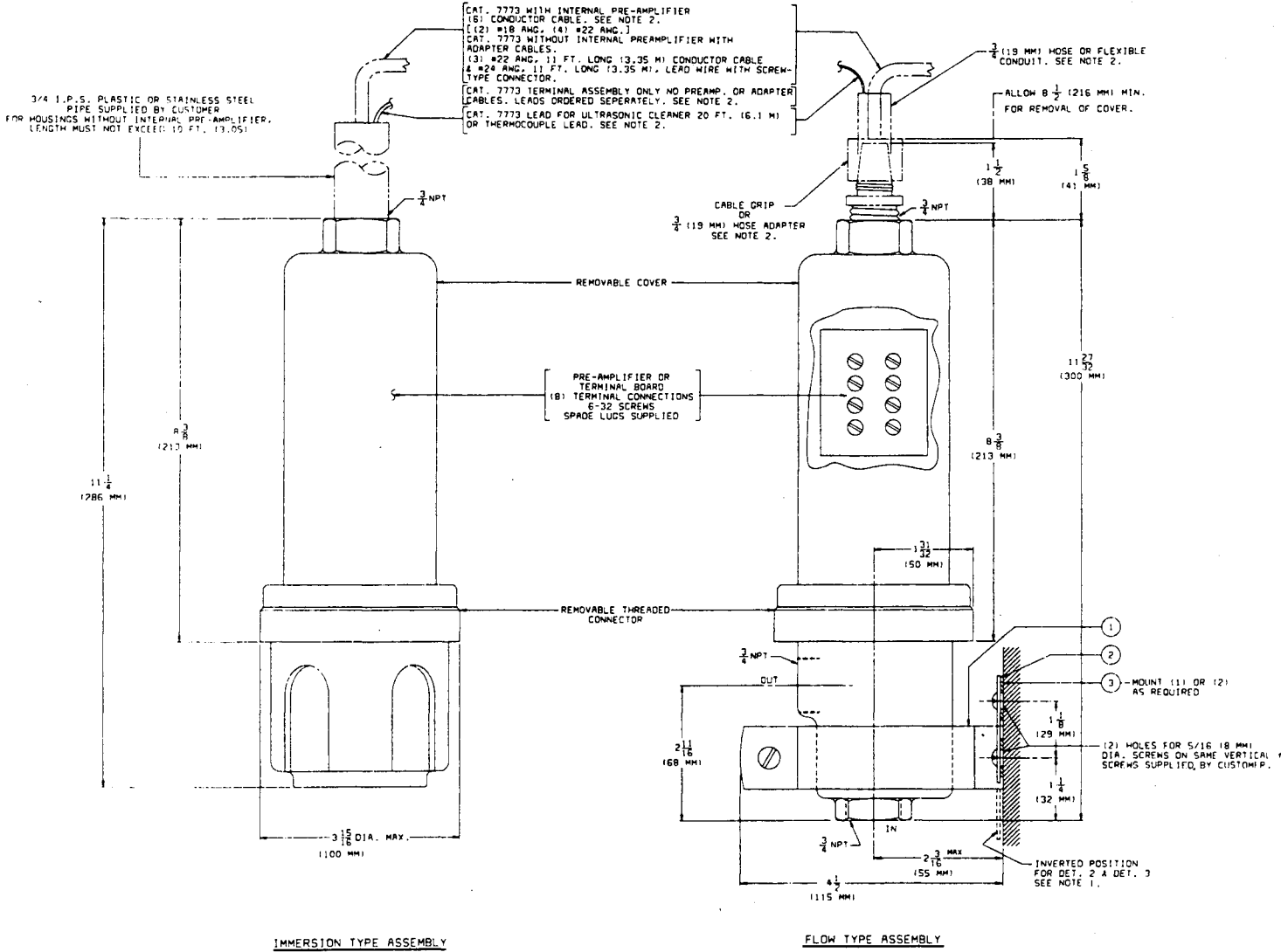
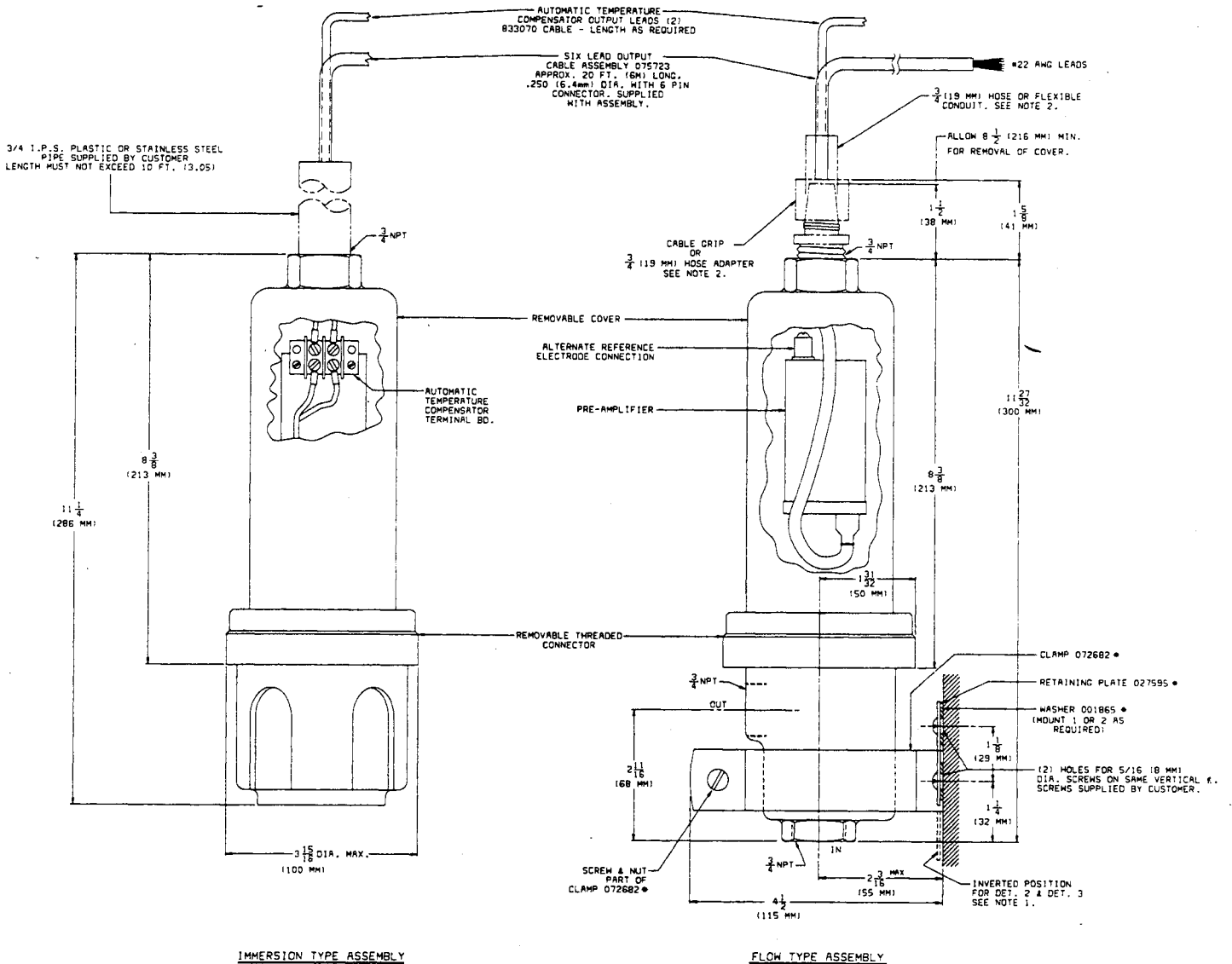

Figure 3-8 Drawing No. D-DIM-1577-260 - Outline and Mounting Dimensions of 7773 Electrode Mounting Assembly



- NOTES:**
1. MOUNT FLOW CHAMBER TO SUIT PIPING. IF "OUT" CONNECTION FACES THE MOUNTING SURFACE, PROVIDE BLOCK FOR CLAMP MOUNTING & TURN DET. 3 & DET. 3 TO INVERTED POSITION SHOWN.
 2. MATERIAL ORDERED SEPARATELY.
 3. * - PARTS SUPPLIED AS KIT 32443B

Figure 3-9 Drawing No. D-DIM-227-1 - Outline and Mounting Dimensions of 7773 Electrode Mounting Assembly

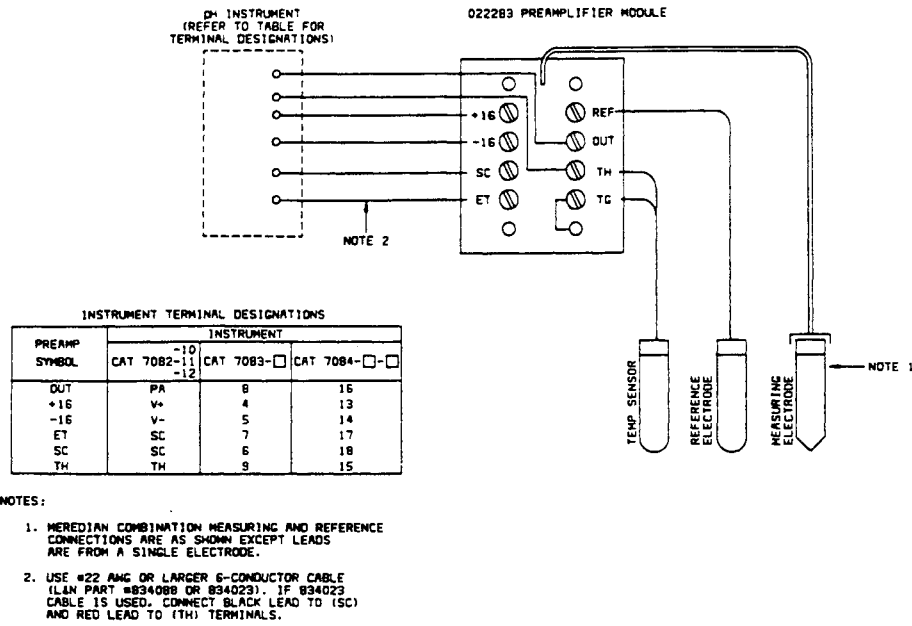

Figure 3-10 Drawing No. B-10-081606-5 - Installation Diagram for pH Electrode Mounting Assembly 7773-6- and 7773-6

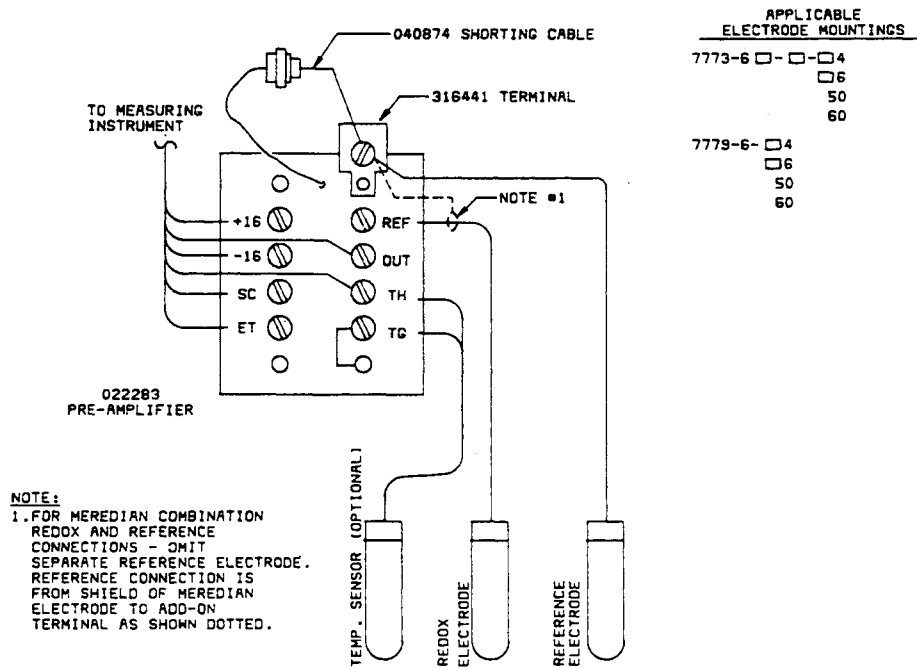

Figure 3-11 Drawing No. A-ID-081606-10 - ORP Electrode Connections to 7773-6- and 7773-6

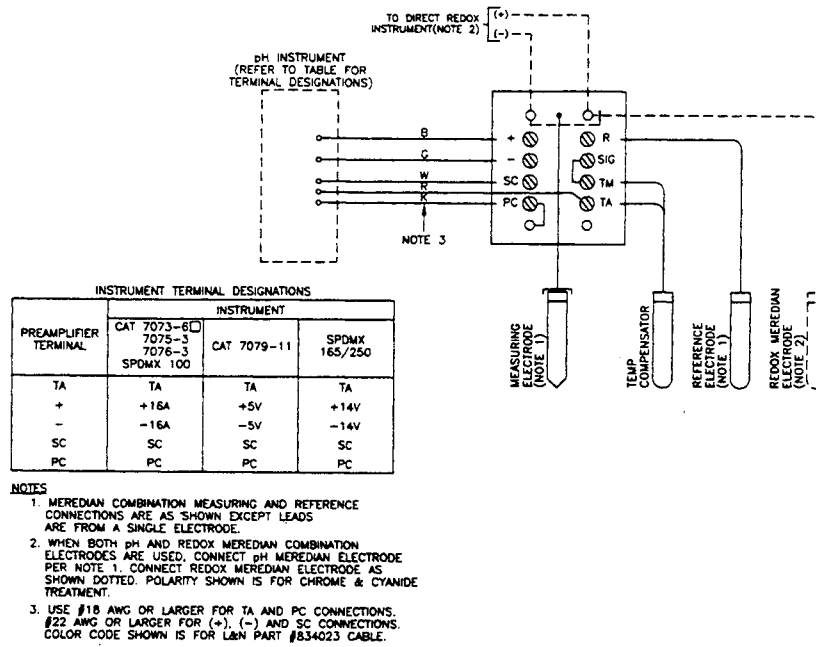

Figure 3-12 Drawing No. A-ID-081606-12 - pH Electrode Connections for 7773-1 , 4 , 5 , and 7779-3,5 Electrode Mounting Assembly

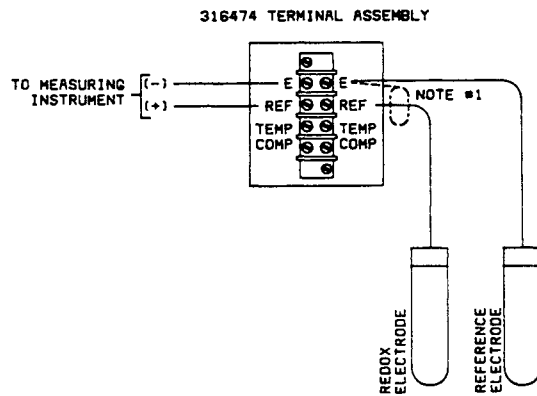

Figure 3-13 Drawing No. ID-081606-13 - ORP Electrode Connections for 7773-30 and 7779-4 Electrode Mounting Assembly

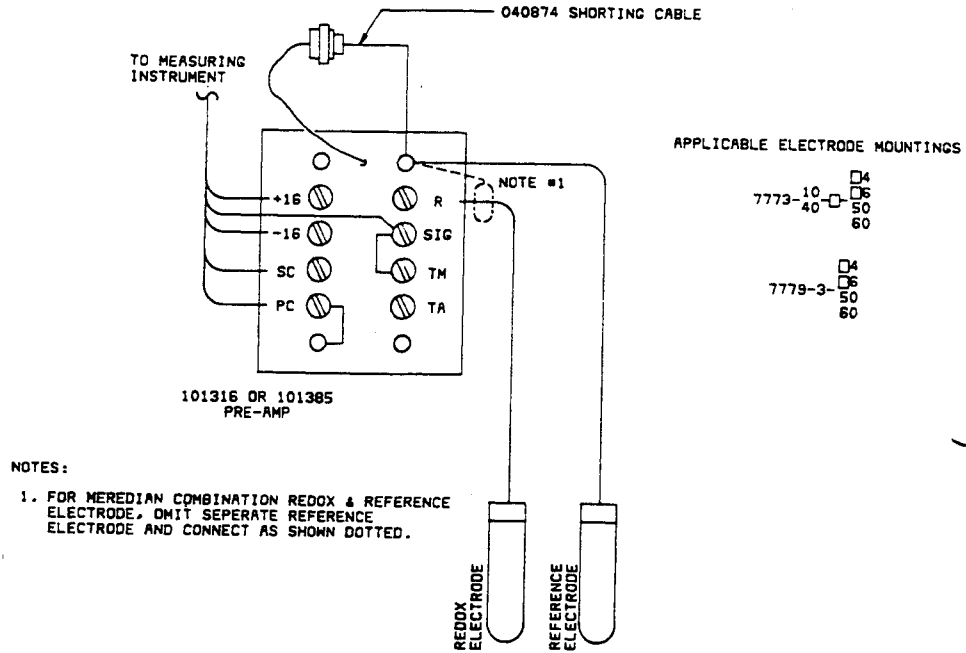
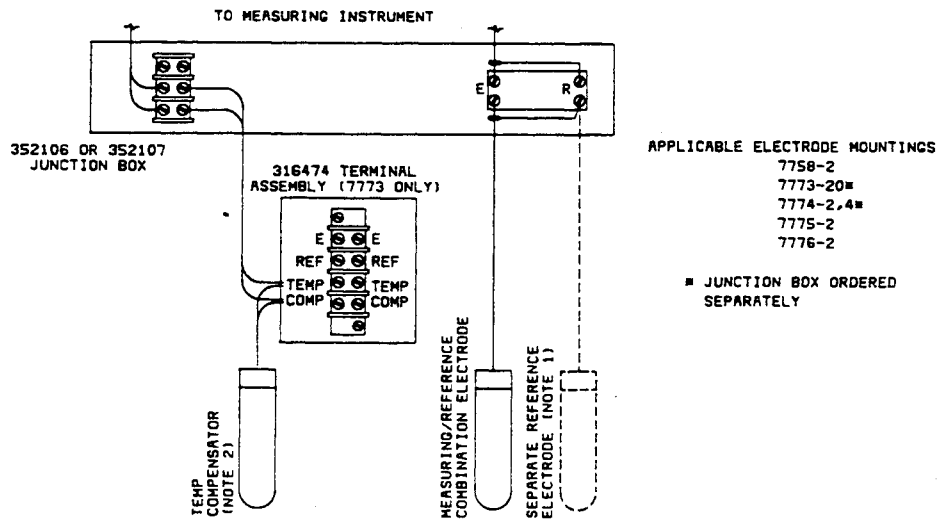
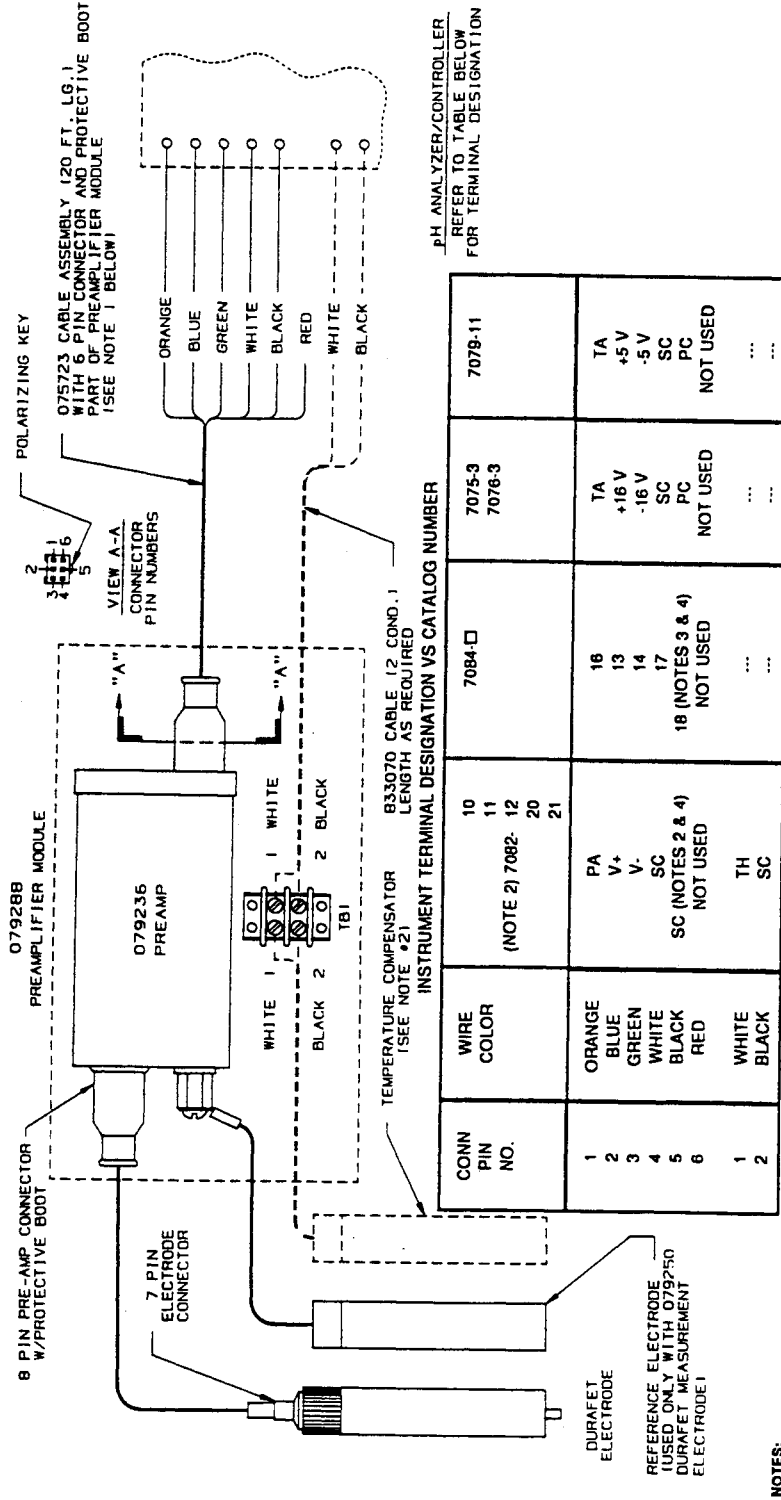

Figure 3-14 Drawing No. A-ID-081606-15 - ORP Connections for 7773-10, 40 and 7779-3 Electrode Mounting Assembly with Preamp



- NOTES:
1. WITH SEPARATE MEASURING AND REFERENCE ELECTRODES, CONNECTIONS INCLUDE THE REFERENCE ELECTRODE SHOWN DOTTED.
 2. COMBINATION ELECTRODE WITH INTEGRAL TEMP COMPENSATOR CONNECTS AS SHOWN EXCEPT THAT ALL LEADS ARE FROM A SINGLE ELECTRODE AND GO DIRECTLY TO THE JUNCTION BOX.

Figure 3-15 Drawing No. ID-081606-16 - pH Electrode Connections for Direct Measurement Using a Junction Box



- NOTES:**
- WHEN DISTANCE FROM PREAMPLIFIER MODULE TO INSTRUMENT IS GREATER THAN 20 FT., USE 6 CONDUCTOR #22 AWG CABLE (LAN P/N 634088 OR EQUIV) AND JUNCTION BOX (LAN P/N 316260). IF COMPENSATOR LEADS ARE TO BE EXTENDED, USE JUNCTION BOX (LAN P/N 316735).
 - (a) CONNECT 233300 RESISTOR (8550 OHMS) BETWEEN TERMINALS "TH" AND "SC" OF CAT. 7082 IF TEMPERATURE COMPENSATOR IS NOT USED. TEMPERATURE COMPENSATOR USE IS LIMITED TO CATALOG 7082 MANUFACTURED AFTER SEPTEMBER 1990 WITH PROMs (U7); 066437 REV. E AND LATER - SINGLE OUTPUT; 120174 REV. B AND LATER - MULTIPLE OUTPUT
 - IF 7082 UTILIZES 080239 INTERNAL PREAMPLIFIER KIT, FOLLOW DIRECTIONS IN MANUAL 276878 SUPPLIED WITH KIT.
 - CONNECT 233300 RESISTOR (8550 OHMS) BETWEEN TERMINALS "15" & "18" OF CAT. 7084.

Figure 3-16 Drawing No. L-227 - Installation Diagram for Durafet® pH Electrode with 7773 Multipurpose Mounting Assembly

4. Maintenance

4.1 General

Maintenance consists of standardizing the system and cleaning the electrodes. The interval between these operations depends upon the nature of the sample, whether it is clean or not, and the accuracy required.

4.1.1 Standardizing

The “grab sample” and “buffering” methods are used to standardize pH measurements. For the grab sample method, take a sample from the process and measure it on a second instrument which has previously been standardized against a standard reference solution (buffer). Observe the reading of the process instrument at the time the sample is taken. (Try to collect the sample from an area near the electrode to make certain it represents the pH the process electrodes are sampling.) Measure the sample on the second instrument and adjust the process instrument by the difference between this reading and the reading observed at the time the sample was taken.

For the buffering method, place the electrodes from the housing directly into a standard reference solution (buffer) having a pH value and temperature near that of the process. Adjust the measuring instrument to read the value of the standard solution.

Refer to the pH measuring instrument manual for detailed information on standardizing.

4.1.2 Disassembly

1. To expose the electrodes, remove the flow chamber or the protector. In the case of the flow assembly, first release any process pressure.
2. Remove the connector ring and slide it up to the top of the cover.
3. Place a screwdriver in the slot between the support flange and the flow chamber or protector, and pry them apart. Slots are provided at opposite sides of the flange for this purpose. Separation is made by alternately prying on one side and then the other.

When disassembling the flow-type unit, hold onto the cover with one hand to make certain it does not tilt and damage the electrodes; for the immersion type, secure the support pipe and hold on to the protector as it is removed.

Separate the cover from the flange assembly in the same manner. Always protect the support assembly with the electrodes during these operations.

4.1.3 Cleaning

If the sample contains materials that coat the electrodes, or if the process has precipitation taking place and the precipitants adhere to the electrodes, it is necessary to establish a schedule for cleaning. Disassemble as in Section 4.1.2 and clean the electrodes with water, detergents or dilute acids. See directions for the electrodes for details.

When reassembling the unit, make certain that no salts or other granular matter is on the O-rings or the contacting surfaces of the O-ring. If an electrode or compensator is removed, make certain the unit, the O-ring and the O-ring seats are clean before reassembling. After cleaning, coat the surfaces of the O-rings as described in Section 3.1.1.

4.1.4 Care of Preamp Measuring Electrode Connector

The guarded-circuit feature serves to eliminate leakage in the high impedance input; however, to insure good operation, it is important to protect the inside of the connector from moisture and dirt. When not in use, attach the connector to the shorting plug to keep it clean. Do not touch the center contact of the connector with bare hands as body oils and salts can cause contamination.

To clean the connector, use a toothbrush and scrub with Ivory soap or clear detergent. Rinse thoroughly with water and allow to dry. In some cases, ACS Grade 99.9% isopropyl alcohol is effective as a cleaner. A cotton swab or cotton ball can be used, but all lint and fibers must be rinsed off before using.

4.1.5 Care of Ultrasonic Electrode Cleaner

Refer to Manual 70-82-25-43.

4.2 Accessories

Refer to the appropriate drawing listed in Table 3-2.

4.2.1 Accessories for 7773-1□

1. 834023 6-Conductor Cable, length as specified,
2. 31074354 Cable Grips, aluminum body, (2) required,
3. 31316260 Junction Box; required when it is not desirable to run a continuous lead from preamplifier to instrument for measuring transmitted signal,
4. 276198 Hose Adapter,* (2) required,
5. 072283 Hose Clamp,* (2) required, and
6. 31820018 3/4" I.D. Rubber Hose, * length as specified.

4.2.2 Accessories for 7773-2□ or -3□

When ordering the following, specify cable length between junction box and direct reading instrument.

1. 31835002 Low-loss Coaxial Cable for interplant connections.
2. 833002 Conductor Cable for automatic temperature compensation for direct measuring pH instruments.

4.2.3 Accessories for 7773-70, -80

1. 31834088 6-Conductor Cable, length as specified,
2. 31074354 Cable Grips, aluminum body, (2) required,
3. 31316260 Junction Box for Table I = 70 only; required when cable run from preamplifier to instrument exceeds 20-feet,
4. 276198 Hose Adapter,* (2) required,
5. 072283 Hose Clamp,* (2) required, and
6. 31822018 3/4" I.D. Rubber Hose,* length as specified.

* The hose clamps and hose adapter can be used in place of the cable grips to provide greater protection to the cable.

4.3 Replacement and Conversion Parts

Chemicals and Buffers

31103001, 31103002, 31103003: Each bottle is printed with the pH value over the temperature range 0 to 95°C and contains the following statement:

This buffer solution was checked to with ± 0.010 pH of a National Institute of Standards & Technology primary standard buffer solution. The estimated uncertainty of these values between 0 and 50°C does not exceed ± 0.010 pH. Above 50°C, this uncertainty is ± 0.015 pH.

- 31103001 Reference Buffer Solution 4.008 pH at 25°C. One pint in polyethylene bottle, easily identified by red bar-stripe.
- 31103002 Reference Buffer Solution 6.865 pH at 25°C. One pint in polyethylene bottle, easily identified by green bar-strip.
- 31103003 Reference Buffer Solution 9.18 pH at 25°C. One pint in polyethylene bottle, easily identified by blue bar-stripe.
- 31103016 Drierite, 3-1/2-oz. -- desiccant for high impedance junction boxes in humid areas.
- 31103065 Diffusion-Type Reference Electrode Recharging Crystals, (6) 1/2-oz. packages. May be used to recharge both slurry-filled and gel-filled electrodes. However, the recharged electrode will then be equivalent to a slurry-filled electrode.
- 31079188 Gel Refill Kit for 079220 Durafet® Electrode

Conversion to Durafet® Electrodes

- 31084741 Durafet® Retrofit Kit; Includes preamp, bracket, retainers, cables, terminal board, resistor and hardware to convert 7773 from glass electrode to Durafet® electrode. Order Durafet® electrode separately.

Maintenance Kit (except 7773-70, -80)

- 31324441 Kit with (2) 117389, -5 to +40°C pH Measuring Electrodes
- 31324442 Kit with (2) 117390, 10 to 80°C pH Measuring Electrodes
- 31324443 Kit with (2) 117391, 40 to 100°C pH Measuring Electrodes
- 31008473 Kit with (1) 117486, 10 to 100°C Meredian Electrodes

Replacement Electrodes and Automatic Temperature Compensators

Table 4-1 Replacement Electrodes and Automatic Temperature Compensators

Part No.	Function	Construction	Temp Range	Lead & Termination	Pressure Limit
MEASURING: pH					
31117399	2-11 pH range	Antimony/Ryton	5-75°C	Screw Cap	150 psig @ 75°C
31117389	0-11 pH range due to Na ⁺ error	Glass/glass	-5 to +40°C	Screw Cap	100 psig @ 110°C 150 psig @ 80°C
31117390	pH meas	Glass/glass	10-80°C	Screw Cap	100 psig @ 110°C; 150 psig @ 80°C
31117391	pH measure	Glass/glass	40-110°C	Screw Cap	100 psig @ 110°C; 150 psig @ 80°C

Part No.	Function	Construction	Temp Range	Lead & Termination	Pressure Limit
31079250	Durafet® range 0-14 pH	ISFET/Ryton	-10 to 110°C	Screw Cap, 7-pin	150 psig @ 80°C
Part No.	Function	Construction	Temp Range	Lead & Termination	Pressure Limit
MEASURING: ORP					
31117419	ORP meas	Gold/Ryton	-5 to +110°C	6" (15 cm) w/ spade lug	150 psig @ 110°C
31117418	ORP meas	Platinum/Ryton	-5 to +110°C		150 psig @ 110°C
MEASURING: SPECIFIC ION					
31117485	Fluoride ion meas	Lanthanum Fluoride/Epoxy	0-80°C	Screw Cap	50 psig @ 80°C
31117402	Chloride ion meas	Silver Chloride/Epoxy	0-50°C	Screw Cap	50 psig @ 50°C
COMBINATION MEASURING/REFERENCE ELECTRODES					
31117486	Meredian range 1-13 pH	Glass/Ryton	10-100°C	Screw Cap 6" (15 cm) w/spade lug	30 psig @ 100°C; 50 psig @ 80°C; 100 psig @ 60°C
31117494	Meredian range 1-11 pH; above 100°C, 1-9 pH	Glass/Ryton	20-130°C	Screw Cap 6" (15 cm) w/spade lug	100 psig @ 60°C; 75 psig @ 100°C; 50 psig @ 130°C; for sterilization only,
31079220	Durafet® range 0-14 pH	ISFET/Ryton	1-10 to +110°C	Screw cap, 7-pin	continuous @ 25°C 150 psig @ 80°C
REFERENCE					
31117481	Ref w/replacement 109069 ceramic plug	Gel/Ryton	-5 to +110°C	6" (15 cm) w/spade lug	150 psig @ 60°C; 50 psig @ 110°C
31117392	Ref w/replacement 109069 ceramic plug	Slurry/Ryton	-5 to +110°C	6" (15 cm) w/spade lug	150 psig @ 60°C; 50 psig @ 110°C
31117484	Reference	Gel/glass	-5 to +130°C	2" w/spade lug	100 psig @ 110°C; 150 psig @ 80°C
31117300	Reference	Slurry/glass	-5 to +130°C	2" w/spade lug	100 psig @ 110°C; 150 psig @ 80°C
31035832	Ref double junction	Gel/Ryton	-5 to +110°C	6" (15 cm) w/spade lug	150 psig @ 60°C; 50 psig @ 110°C
31008712	Flowing junction ref elec	Glass (included in 035974 kit)	-5 to +110°C	6" (15 cm) w/spade lug	Atmospheric pressure
AUTOMATIC TEMPERATURE COMPENSATORS (ATC)					
31152139	Temp Comp	Glass	-5 to 130°C	6" (15 cm) spade lug	150 psig @ 130 °C
31152137	Temp Comp	Ryton	-5 to 130°C	6" (15 cm) spade lug	150 psig @ 60°C; 50 psig @ 110°C
31022289	Temp comp for µP instr only	Ryton	-5 to +110°C	6" (15 cm)	150 psig @ 110°C
31022291	Temp comp for µP instr only	Glass	-5 to +110°C	6" (15 cm) spade lug	150 psig @ 110°C