

DL424/425 DirectLine® Sensor Module for DL5000 Dissolved Oxygen Probes

70-82-03-48

1/03

Page 1 of 8

Specification

Overview

The DirectLine® DL424/425 Sensor Modules are part of a family of products developed by Honeywell as part of a new generation of analytical instruments. The unique architecture of the DirectLine® module combines the latest in microelectronics technology with the proven performance of Honeywell's DL5000 dissolved oxygen *equilibrium* probe to provide unequalled savings during installation, start-up, operation, and maintenance.

The DirectLine® electronics module can be mounted integrally or remotely on the DL5000 probe. It provides a 4-20 mA dc output proportional to dissolved oxygen. The output of the DirectLine® sensor connects directly to any host monitor or control device that accepts standard 4-20 mA inputs and provides external loop power including:

- Honeywell UDC3300 1/4-DIN Controller
- UMC800 Controller
- PLCs with analog inputs
- DCS systems
- A host of other recorder/controller products

Description

The Honeywell DirectLine® architecture consists of an electronics module integral to a sensor or probe. This design eliminates the need and added cost of a separate analyzer or transmitter.

The electronics module is sealed in a plastic weatherproof, corrosion-resistant housing and is connected to the DL5000 dissolved oxygen probe on one side and a 4-20 mA output cable on the other via waterproof connectors. This housing design allows this system to be used in harsh environments where moisture and dust is a problem.

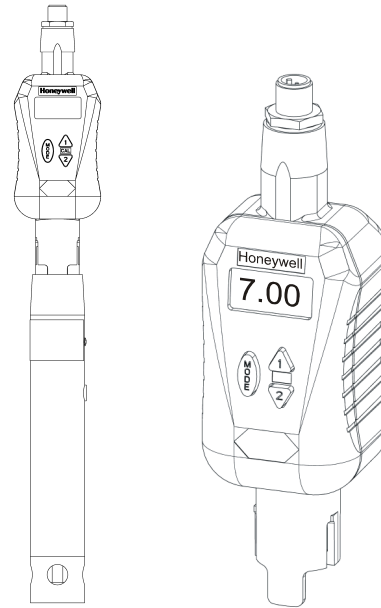

Figure 1—DirectLine® DL424/425 Sensor Module

Description, continued

For submersion or special mounting applications, a remote mounting option is available which connects the electronics module to the DO probe via a cable. The module can be mounted on a 2-inch pipe, wall or DIN rail.

Features

- **Direct 4-20 mA output** eliminates need for dedicated analyzers or transmitters, simplifying installation, start-up, operation, and maintenance tasks. Installation costs are also reduced since standard cable can be used for additional cable distances.
- **Integral electronics with local HMI** simplifies installation and shortens calibration times.
- **Plug-in modular design** allows probe to be safely removed and replaced without cycling power on the electronics module.
- **½" NPT conduit** Connection provides increased protection and noise immunity of output cable

Features, continued

- **Local display and keypad** facilitates quick set-up, calibration, and operational activities.
- **Electronics and probe diagnostics** reduces troubleshooting times.
- **Air and sample calibration options** accommodate individual calibration techniques and reduces calibration time.
- **Playing card-sized guide** facilitates simple, correct, and consistent calibration and configuration.
- **Watertight sensor connection** for reliability in submersion applications.
- **Global approvals** including:
 - UL General Purpose
 - CSA General Purpose
 - IP66 Enclosure
 - NEMA4X Enclosure
 - CE
 - FM Class I, Div 1
 - FM Class I, Div 2 (non-incendive field wiring)

Electronics Module

Integral Electronics/Sensor Design

The DirectLine® electronics module is loop-powered by 16-42 Vdc source and will modulate its supply current from 4-20 mA, depending upon the DO value sensed by the DL5000 probe.

The *output* cable connects to the electronics module by a waterproof connector. The DirectLine® sensor's output cable connector is a standard M12 type receptacle. The M12 receptacle easily connects to a cord-set with an M12 connector or an M12 field wiring connector and customer-supplied cable.

The DL424/425 module quickly attaches to the probe and is easily locked-in-place for assured safety and reliability during operation. The probe can be removed from the module safely without disrupting power to the electronics.

Submersion Applications

For submersion or special wiring applications, a remote electronics module option is available. The remote electronics module can be mounted on a 2-inch pipe, wall, or DIN rail. The remote probe cable is supplied with the DL5000 probe. It directly connects the electronics module to the probe with a submersible connector.

Operator Interface

The DirectLine® electronics module configuration, calibration, and maintenance functions are performed locally from three buttons and a 4-digit, 7-segment LCD display on the front side of the electronics module. The process variable, temperature (if available), and any error diagnostics are viewable from the local LCD display.

The following configuration functions are available.

- New Probe Reset
- Air Calibration
- Sample Calibration
- Atmospheric pressure Compensation
- Salinity Compensation (ppm only)
- Probe Bias Voltage
- Output configuration
- Noise suppression frequency selection

The Honeywell DirectLine® sensor eliminates the extra time needed to travel back and forth between the analyzer/transmitter and probe location while performing a calibration. The DL424/425 offers two calibration options: Sample and Air calibration.

A playing card-sized guide comes with each DirectLine® sensor to guide you through a configuration or calibration quickly.

Online Diagnostics

The DirectLine® sensor continuously performs self-diagnostics on both the electronics and sensor. These prioritized self-diagnostics help to minimize the time and expense of troubleshooting during start-ups, maintenance, and calibrations.

If a problem arises with either the module electronics or the sensor, the software prioritizes the problem type and displays only the highest priority error diagnostic thus simplifying the troubleshooting process. Once the diagnostic is corrected, the error code disappears from the display.

Online Diagnostics, continued

If the electrode's temperature or process variable value goes out of operation range, the output current is driven to approximately 21.8 mA to inform the host device of a problem. Once the problem is corrected, the output current is returned back to normal and the error code disappears. Error codes are also used to indicate calibration failures.

DL5000 DO Probes

DL5000 dissolved oxygen probes are based on a unique equilibrium probe technology which results in a probe which is:

- Unaffected by fouling or changes in sample flow
- Requires no periodic replacement of anode or electrolyte
- Features a heavy membrane which eliminates replacement requirements
- Available in PVC and stainless steel housings; ppm or ppb configuration; integral and remote mountings

The DL5000:

- can be mounted using immersion, insertion or flow-through mountings
- measures and displays temperature as well as dissolved oxygen concentration

Specifications

Displayed Process Variable	DL424: 0-20 ppm dissolved oxygen in 1 ppm increments; DL425: 0-200 ppb dissolved oxygen in 1 and 10 ppb increments
Displayed Temperature Range	2.0 to 60.0 °C (35.6 to 140°F)
Operating Temperature	-20 °C to +60 °C (-4 °F to +140 °F)
Storage Temperature	-20 °C to +70 °C (-4 °F to +158 °F)
DL424/425 Output Accuracy with DL5000 Probe	ppm: +/- 0.2ppm after stabilization ppb: +/-2ppb or 5% of reading after stabilization, whichever is greater
DL424/425 with DL5000 Probe Measurement Response	90% of value in 1 minute (after probe warm-up)
Display Resolution	DL424: 0.01 ppm DL425: 0.1 ppb in the 0-20 ppb range; 1 ppb in the 0-200 ppb range
Output Type	4-20 mA (2-wire loop powered)
Output Calibration	4-20 mA
Power	16-42 Vdc Maximum Load Resistance: 250 ohms at 16 Vdc 600 ohms at 24 Vdc 1400 ohms at 42 Vdc
Calibration Options	Air ; Sample Cal
Diagnostics	Sensor and electronics

Physical Properties:

Case	Weatherproof, corrosion-resistant plastic housing
Local Display and Buttons	LCD 4-digit, 7-segment
Output Cable Type	Shielded twisted pair
Output Cable Connection:	M12 type
User Termination	Tinned leads on cord set or customer supplied cable
Remote Mounting	Pipe, Wall, or DIN Rail
Dimensions	H 123 mm (4.84") x W 48 mm (1.89") x D 46 mm (1.81")
Weight	Approximately 142 g (5.0 oz.)

Approvals	UL – General Purpose CSA – General Purpose Enclosure: Type 4x, IP66 FM intrinsically safe, Class I, Div. 1, Groups A, B, C, D and Class I, Zone 0, A Ex ia IIC FM Class I, Div. 2, Groups A, B, C, D and Class I, Zone 2, Groups IIC
------------------	--

Dimensions

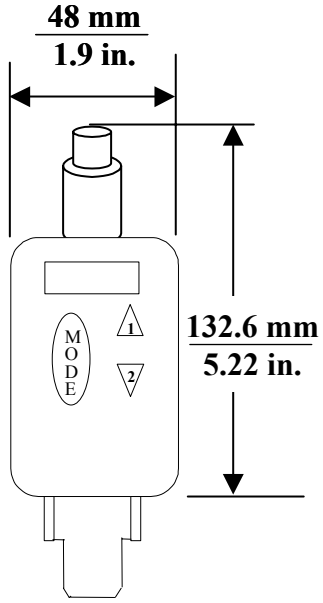

Front View

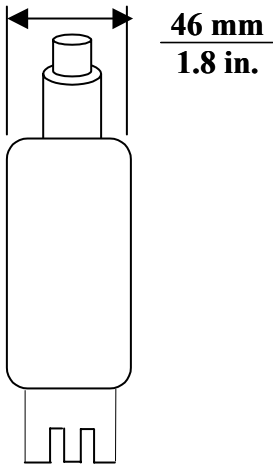

Side View

Figure 2—Dimensions

Integral Mounting

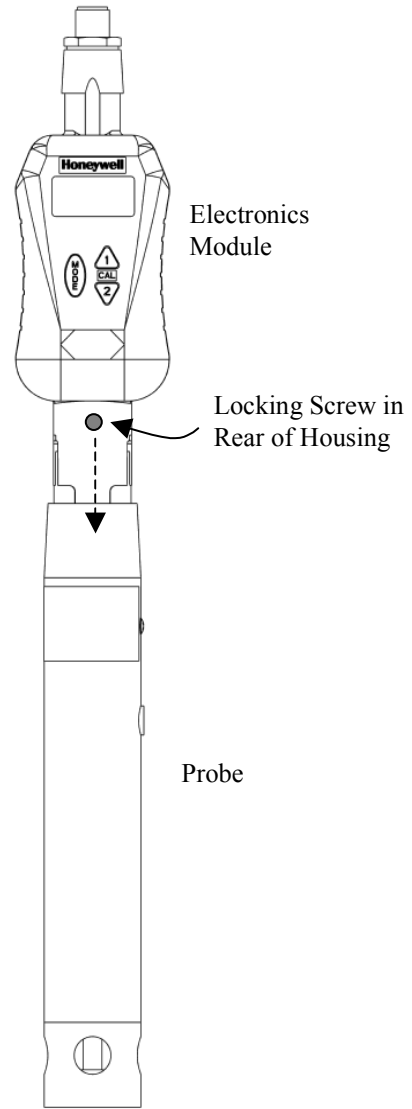

Figure 3—Integral Mounting of Electronics Module with DL5000 DO Probe

Remote Mounting

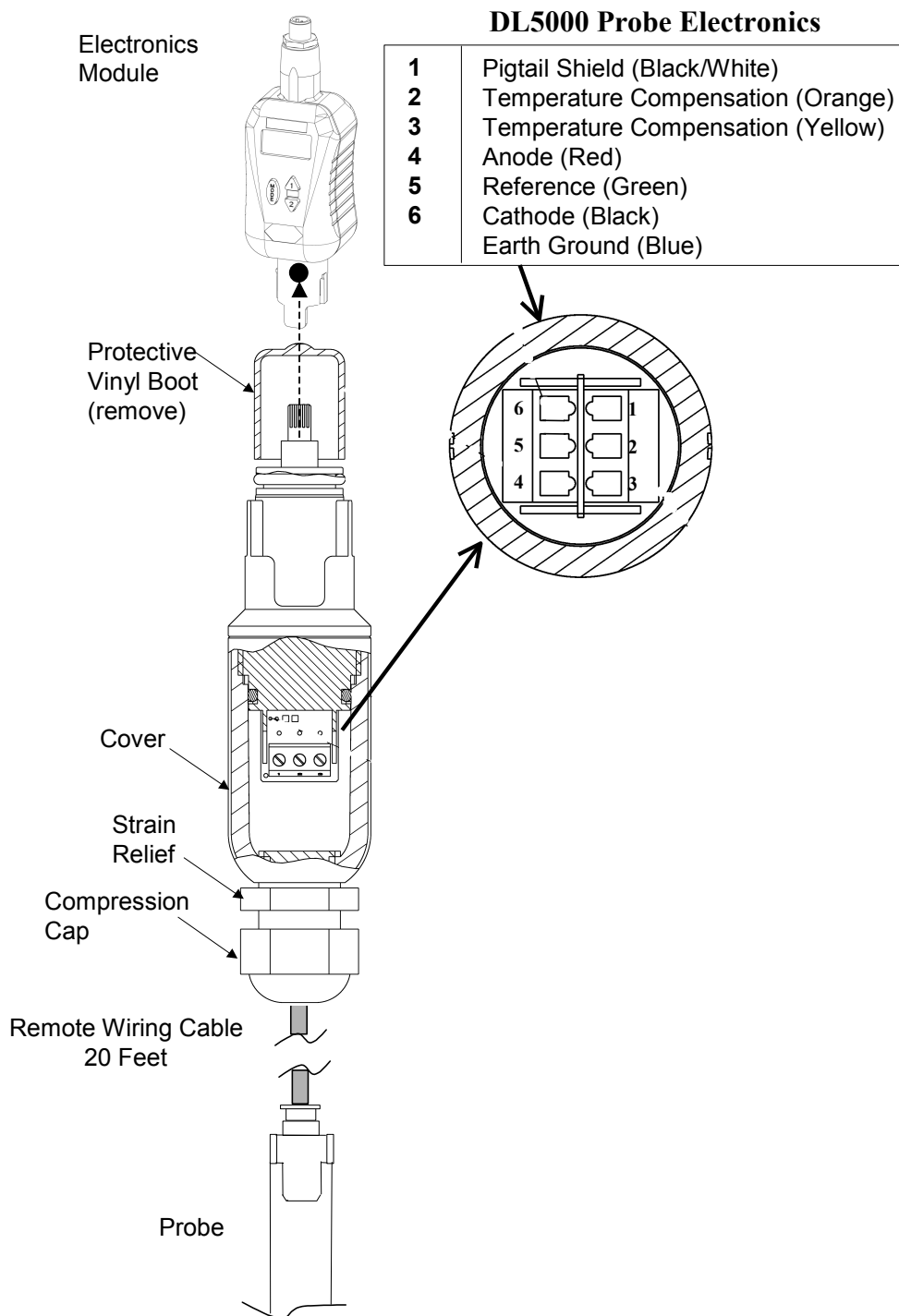
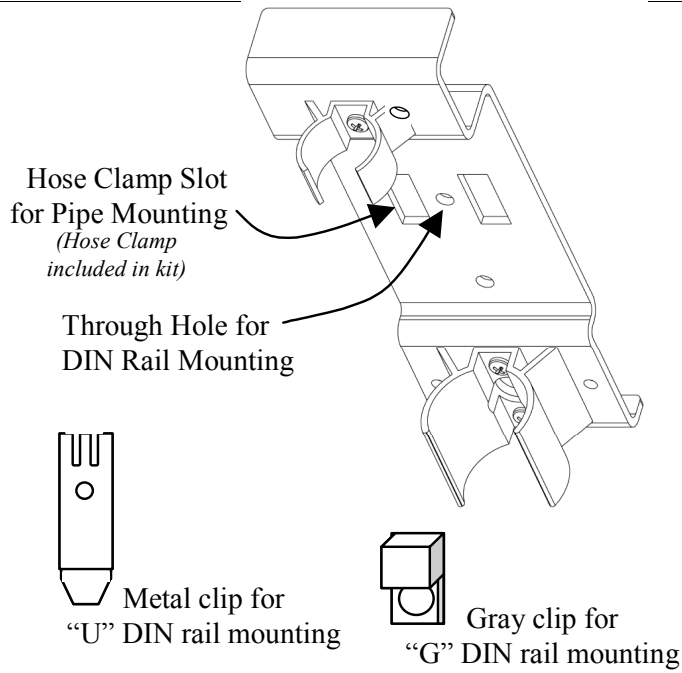

Figure 4—Remote Mounting of DL424/425 Sensor Module with DL5000 Dissolved Oxygen Probe

Remote Mounting Hardware



Mounting Kit

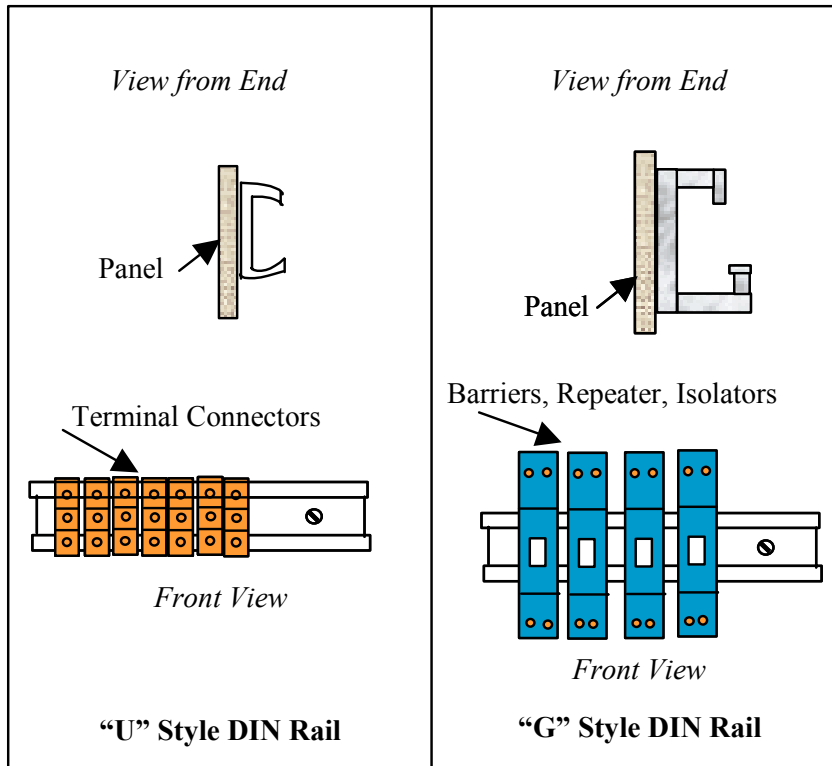
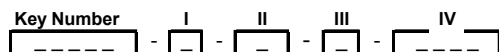

Figure 5—Remote Mounting Hardware

Model Selection Guide

Instructions

- Select the desired key number. The arrow to the right marks the selection available.
- Make the desired selections from Tables I through IV using the column below the proper arrow. A dot (•) denotes availability.



Key Number - DirectLine® Sensor Electronics Module

(Specify electrodes/cells/probes separately)

	Selection	Availability
pH	DL421	↓
ORP	DL422	↓
Conductivity	DL423	↓
DO - PPM	DL424	↓
DO - PPB	DL425	↓

TABLE I - OUTPUT CABLE

	Selection	Availability
Output Cable for Integral or Remote Mounting	None (replacement module or customer supplied output cable)- Note 1	D • • • • •
	Cordset - 6m (19.7 ft.) - includes connector and cable - Note 2	E • • • • •
	Field Wiring Connector only - customer supplies cable only- Note 2	F • • • • •

TABLE II - SENSOR CABLE/REMOTE CONNECTOR (between electronic module and electrode, sensor or probe)

	Selection	Availability
Integral Mounting	No cable or connector required	0 d d d d d
Remote Mounting Cable - Durafet only	6,096m (20 ft.) of sensor cable - Durafet II Remote Mounting	1 e
	15,24m (50 ft.) of sensor cable - Durafet II Remote Mounting	2 e
Remote Mounting Connector (Cable is supplied with sensor or probe)	Remote Mounting Connector - Meredian II pH	3 e
	Remote Mounting Connector - Meredian II ORP	3 e
	Remote Mounting Connector - HPW7000	4 e
	Remote Mounting Connector - Conductivity	5 e
	Remote Mounting Connector - Dissolved Oxygen	6 e e

TABLE III - REMOTE MOUNTING OPTIONS

	Selection	Availability
Mounting Kit for Remote Mounting	None Integral unit - mounting not required	A • • • • •
	2" (5,08 cm) Pipe mtg. bracket, wall mtg. & DIN Rail clip	B • • • • •

TABLE IV - OPTIONS

	Selection	Availability
Tagging	None	00 __ • • • • •
	Linen Customer ID Tag - 3 lines w/22 characters/line	LT __ • • • • •
	SS Customer ID Tag - 3 lines w/22 character/line	SS __ • • • • •
Certificates	None	__ 00 • • • • •
	Calibration & Conformance	__ CC • • • • •

Notes:

- 1 Customer supplies cordset **or** cable with M12 connector. Suppliers & P/Ns include:

	Phoenix Contact	Turck
Cord-set	SAC-3P-5.0-PUR/M12FSSH Stainless	RKV4T-6/S618
M12 Field Wiring Connector	SACC-M12FS-4CON-PG7	B8141-0
Cable	2-wire twisted shielded pair	

- 2 Recommended cable is 2-wire twisted shielded pair

RESTRICTIONS

Restriction Letters	Available Only With		Not Available With	
	Table	Selection	Table	Selection
d	III	A		
e	III	B		

ORDERING INSTRUCTIONS:

- Part numbers are provided to facilitate Distributor Stock.
- Orders may be placed either by model selection or by part number.
- Part numbers are shown within the model selection tables to assist with compatibility information.
- Orders placed by model selection are systematically protected against incompatibility.
- Compatibility assessment is the responsibility of the purchaser for orders placed by part number.
- Items labeled as N/A are not available via the stocking program and must be ordered by model selection.

Warranty/Remedy

Honeywell warrants goods of its manufacture as being free of defective materials and faulty workmanship. Contact your local sales office for warranty information. If warranted goods are returned to Honeywell during the period of coverage, Honeywell will repair or replace without charge those items it finds defective. The foregoing is Buyer's sole remedy and is **in lieu of all other warranties, expressed or implied, including those of merchantability and fitness for a particular purpose**. Specifications may change without notice. The information we supply is believed to be accurate and reliable as of this printing. However, we assume no responsibility for its use.

While we provide application assistance personally, through our literature and the Honeywell web site, it is up to the customer to determine the suitability of the product in the application.

Distributor :

For more information, contact Honeywell sales at 1-800-343-0228.

Honeywell

Industrial Measurement and Control

Honeywell
1100 Virginia Drive
Fort Washington, PA 19034