

APT4000 Series 4-Wire Contacting Conductivity Analyzers

Specification

Overview

The Honeywell Analytical Process Analyzer (APT) 4000 Series2 continuously measures conductivity, resistivity and salinity in industrial processes within the power, chemical, pharmaceutical, pulp and paper, and water quality industries.

The APT4000's NEMA 4X/IP65-rated enclosure is specifically designed to meet the measurement needs of Class I, Division 2 (non-incendive) and general-purpose areas. The analyzer can be used with Honeywell conductivity cells or electrically compatible sensors. The analyzer has a universal (20-253 V ac/dc, 45-65 Hz) power supply with one 4-20 mA output, two high/low alarm relays, a diagnostic relay, and a wash relay.

Software (USP24) can be used on-line for monitoring the conductivity of purified water or water-for-injection in the pharmaceutical industry.

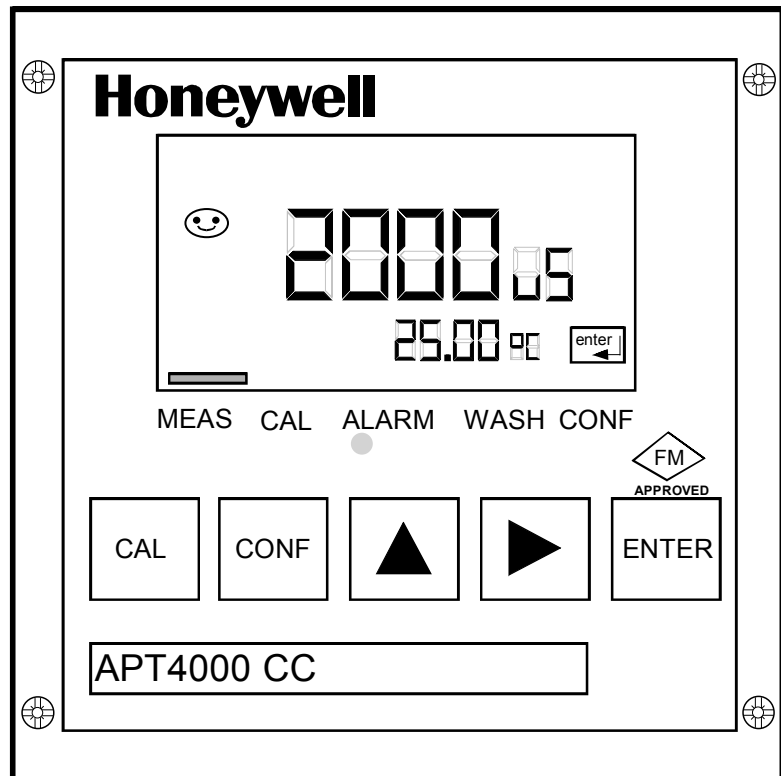

Figure 1—APT4000CC Analyzer

Description

The Honeywell APT4000 series of analyzers offer the widest available selection of advanced features in a reliable and economical instrument.

Reliability First

The advanced features of the APT4000 analyzer guarantee complete reliability. The APT4000 continuously monitors sensor and analyzer electronics and immediately displays diagnostic information at the onset of a problem. If an error or diagnostic is found, the analyzer will indicate the appropriate error code or pictograph (see Figure 2), blink a red LED and adjust the error current to 22 mA if desired. A manual loop-back check is available to test the integrity of the 4-20 mA output.

Quick Problem Assessment

The APT4000 has a large front display for quick recognition of process parameters and diagnostics even at a distance. Only the APT4000 employs *visual feedback* to quicken setup and maintenance times and to minimize errors made during calibrations. Visual feedback refers to pictograph type characters that appear on the display both to prompt and respond to operator and process changes.

Pictograph type characters also appear during problem conditions to report diagnostics for easy troubleshooting. There is even a Sensoface[®] pictograph that provides constant feedback to the operator on whether

or not there is a problem with the cell. These easily learned and recognized symbols make the APT4000 an easy-to-use instrument in any language.

Foolproof Calibrations

Each Honeywell conductivity cell comes supplied with one of four sensor factors (0.01, 0.1, 1.0, and 10). The lower cell constants are used for low conductivity water or resistivity measurements, while the higher ones are used for higher conductivity water or salinity measurements. Calibration of the cells is easy by either utilizing a factory-determined calibration factor or performing a simple one-point calibration.

Works with a Variety of Cells

Inputs to the APT4000 Series include all Honeywell conductivity cell types with appropriate temperature compensator and cell constant. These include the 4973 pure water cells,

4974 sanitary cells, 4905 general-purpose cells, and the 4909 insertion/removal cells. In addition, a wide variety of other manufacturers' conductivity cells are compatible.

Fully Certified

Area certification for the ATP4000 is FM Class I, Div. 2, Groups A-D (non-incendive). Each analyzer comes standard with CE.

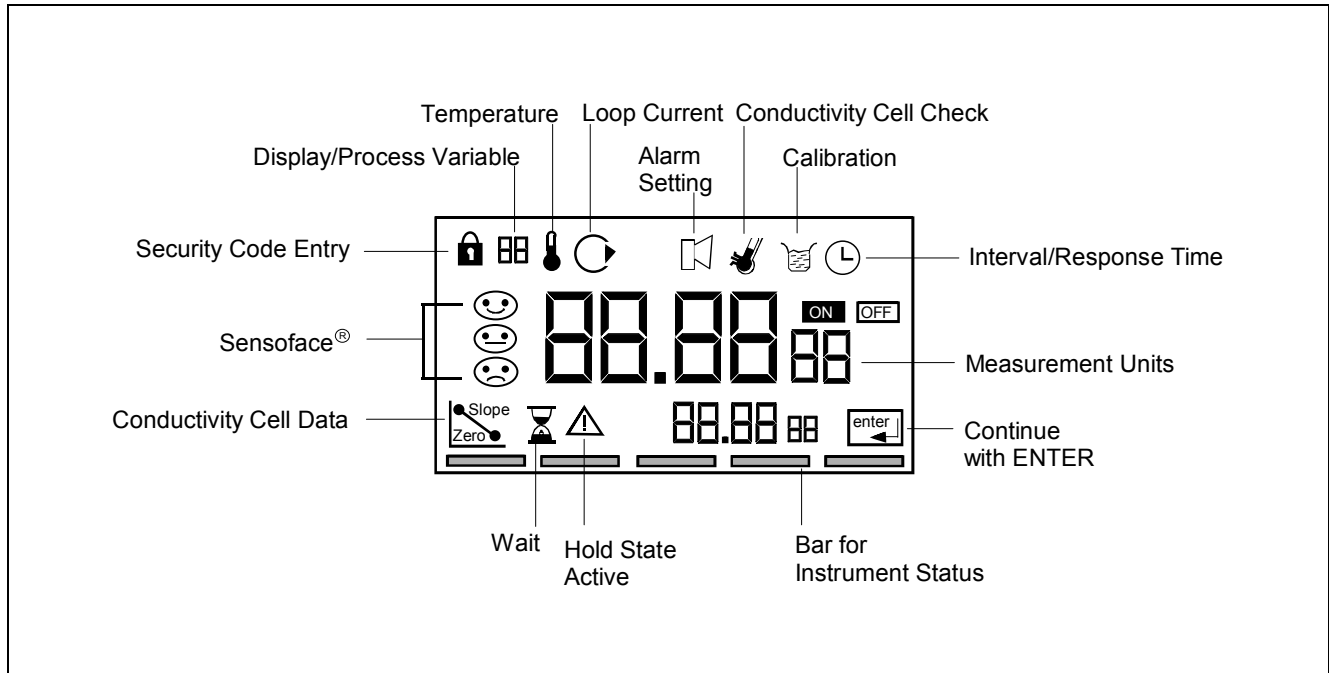

Figure 2—APT4000CC Series 2 Display Features

Features	Applications
<ul style="list-style-type: none"> Large display with easy-to-read 0.75 inch measured value Simple operator interface with basic pictographs Application in Class I, Division 2 or General Purpose areas Continuous diagnostics for monitoring calibration, cell health, and analyzer self-test Manual loopback check for integrity of 4-20 mA output USP 24 Software with USP control limit capabilities. NEMA 4X, IP65 plastic enclosure Remote "hold last measured value capability. 2nd Parameter Set programmable for alternative applications. 	<p>The APT4000CC Analyzer is designed to meet the measurement needs of a number of industries, including:</p> <ul style="list-style-type: none"> Pharmaceutical Water Quality Metals Power Chemical Pulp and Paper
<ul style="list-style-type: none"> Wall, pipe or panel mounting Easy installation with pre-assembled empty enclosure and plug-in terminals Optical alarm with relay contact Quick Response Time (less than five seconds per step change) Dedicated high/low alarm relay 2 Current Outputs available with the 2nd one assigned to temperature. Sensocheck monitors condition of the Conductivity Cell PID (Pulse length and Pulse frequency) software installed. 	

Specifications

Conductivity Input (Refer to Figure 3)	
Display Range	(0.2 $\mu\text{S/cm}$ * Cell Constant) to (1000 mS/cm * Cell Constant)
Accuracy	Less than 1% of Measured Value or \pm (0.4 $\mu\text{S/cm}$ * Cell Constant), whichever is greater
Step Change Response Time	Less than 5 seconds
Process Variable/Range	0.000 to 9.999 $\mu\text{S/cm}$, 00.00 to 99.99 $\mu\text{S/cm}$, 000.0 to 999.9 $\mu\text{S/cm}$, 0000 to 9999 $\mu\text{S/cm}$ 0.000 to 9.999 mS/cm , 00.00 to 99.99 mS/cm , 000.0 to 999.9 mS/cm 0.000 to 9.999 $\text{M}\Omega\text{-cm}$, 00.00 to 99.99 $\text{M}\Omega\text{-cm}$, 000.0 to 999.9 $\text{M}\Omega\text{-cm}$
Salinity	0.0 % to 45.0 % (0 $^{\circ}\text{C}$ to 35 $^{\circ}\text{C}$)
Diagnostics	
Sensocheck	Polarization detection and monitoring of cable capacitance (can be switched off)
Sensor Standardization	- Entry of cell calibration factor with display of conductivity and temperature - Temperature probe adjustment
Sensoface	- Provides information on the electrode state via Sensocheck
USP24 Software	Software for on-line water conductivity monitoring in the pharmaceutical industry
Temperature Input	
Range	<i>8550 Ω Thermistor:</i> -10.0 $^{\circ}\text{C}$ to +130.0 $^{\circ}\text{C}$ (-14 $^{\circ}\text{F}$ to +266 $^{\circ}\text{F}$) <i>Pt100/1000 Ω RTD:</i> -20.0 $^{\circ}\text{C}$ to +150.0 $^{\circ}\text{C}$ (+4 $^{\circ}\text{F}$ to +302 $^{\circ}\text{F}$)
Resolution	0.1 $^{\circ}\text{C}$ or 1 $^{\circ}\text{F}$
Accuracy	< 0.5 K
Temperature Compensation	Automatic Compensation using Pt 100 Ω or 1000 Ω RTD, 8550 Ω Thermistor, or manual adjust
Display	LCD display 76 mm x 48 mm dimensions (3" x 1 7/8"), 7-segment <i>Cond Value:</i> character height 17 mm (.66"), meas. symbol 10 mm (.4") <i>Temperature:</i> character height 10 mm (.4"), meas. symbol 7 mm (.33") Sensoface with three states, 5 status bars, 16 pictographs / symbols, Red Alarm LED Security protection with four-digit mode codes to access calibration and configuration options
Supply/Output	
Output Current	0 mA or 4 mA to 20 mA current loop, 10 V floating Output #1 for Process Variable, Output #2 for Temperature
Supply Voltage	20 V to 253 V ac/dc, 45 Hz to 65 Hz, 2 VA / 1.5 W
Ovrrange	22 mA for error messages
Current Error	< 0.3 % of current value +0.05 mA
Current Source	3.80 mA to 22.0 mA
Output Characteristic	Linear or Logarithmic
Minimum Span	<i>LIN:</i> 5% of the selected range. <i>LOG:</i> 1 decade
PID Function	Relay assignable for PID Control Pulse Length / Pulse Frequency.

Alarms/Relays	
Contacts	<i>Alarm minimum contact:</i> SPST N/O (Hysteresis 0.2% of measured range) <i>Alarm maximum contact:</i> SPST N/O (Hysteresis 0.2% of measured range) <i>Diagnostic contact:</i> SPST N/C <i>Wash contact:</i> SPST N/O
Maximal Current/Voltage	AC: < 250 V / < 3A / < 750 VA DC: < 30 V / < 3A / < 90 W
Physical	
Enclosure	Plastic enclosure made of PBT (polybutylene terephthalate) bluish-gray RAL 7031
Mounting	Wall, Pipe, or Panel Mount
Dimensions	<i>Height:</i> 144 mm (5.67") <i>Width:</i> 144 mm (5.67") <i>Depth:</i> 105 mm (4.13")
Protection	NEMA 4X, IP65
Cable glands	3 breakthroughs for PG 13.5 2 breakthroughs for NPT 1/2" or Rigid metallic conduit
Weight	Approximately 1 kg (2.2 lb.)
Area Certifications / Compliances	
Area Certification	Zone 2 (USA) FM: NI, Class I, Division 2, Groups A-D, T4
Data Retention	Parameters and calibration data > 10 years (EEPROM)
RFI Suppression / Immunity to ESD	To EN 50 081-1 and EN 50 081-2
Ambient Conditions	<i>Operation/Environmental temperature:</i> (T4) -20 °C to +55 °C (-4 °F to +131 °F) (T6) -20 °C to +40 °C (-4 °F to +104 °F) <i>Transport and Storage temperature:</i> -20 °C to +70 °C (-4 °F to +158 °F)

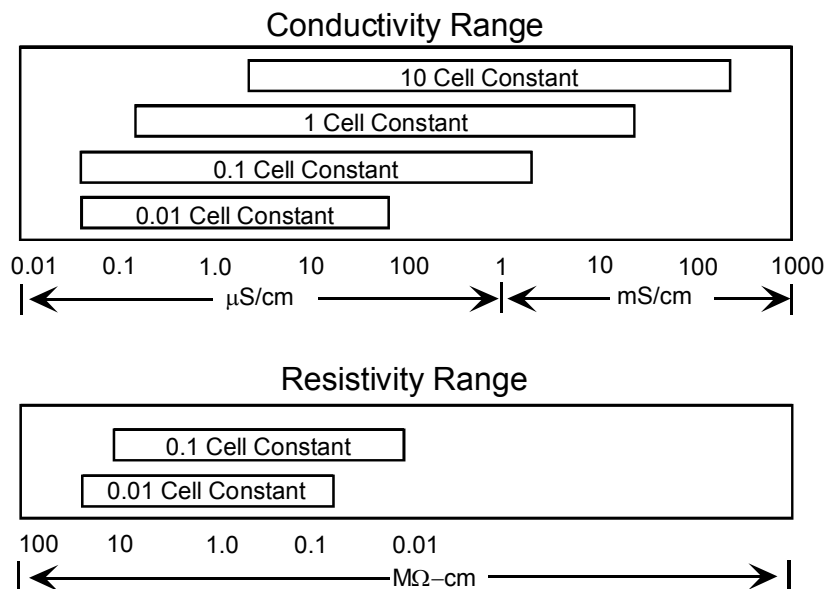

Figure 3—Optimal Cell Constant for Conductivity or Resistivity Ranges

Model Selection Guide

Reference 51-52-16-73

Instructions

- APT4000 Analyzer Offers:
 - Power Requirements - Universal, 20 to 253V AC/DC 45 to 65 Hz
 - Standard - NEMA 4X, IP65
 - Standard Approvals:
 - General Purpose; also FM Class I, Div 2, Groups A-D
 - Standard - All models CE Compliant
 - High/Low Alarm Relays
 - Three mounting types: **(must be ordered separately)**
 - Panel Mount Kit
 - Pipe/Wall Mount Kit
 - Protective Hood (requires Pipe/Wall Mount Kit)

 - Select the desired key number. The arrow to the right marks the selection available.
 - Make one selection from Tables using the column below the proper arrow.
A dot (•) denotes unrestricted availability.
-
- Key Number**
- | | | |
|-------|---|---|
| ----- | - | I |
|-------|---|---|

KEY NUMBER	Selection	Availability		
Description of Measurement Type				
pH/ORP	APT 4000 PH	↓		
Toroidal (Electrodeless) Conductivity	APT 4000 TC		↓	
Contacting Conductivity	APT 4000 CC			↓

TABLE I - Optional Equipment

User's Manual	English	E _ _	•	•	•
Future		_ 0 _	•	•	•
Future		_ _ 0	•	•	•

NOTE: Mounting kit not included with APT4000.

Accessory Parts	Part Number
Mounting Kits:	
Panel Mounting Kit	51205990-001
Pipe/Wall Mounting Kit	51205988-001
Protective Hood (requires pipe/wall kit)	51205989-001
Instruction Manual - pH	70-82-25-103
Instruction Manual - Toroidal (Electrodeless) Conductivity	70-82-25-104
Instruction Manual - Contacting Conductivity	70-82-25-105

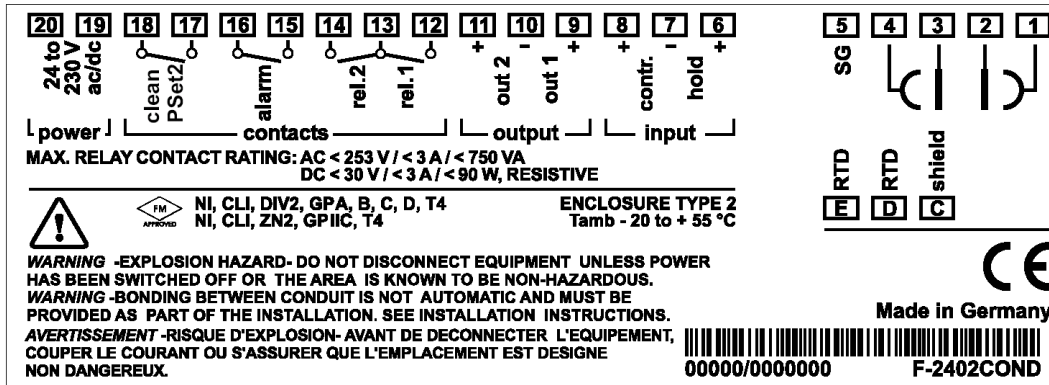

Figure 4—APT4000CC Terminal Assignments

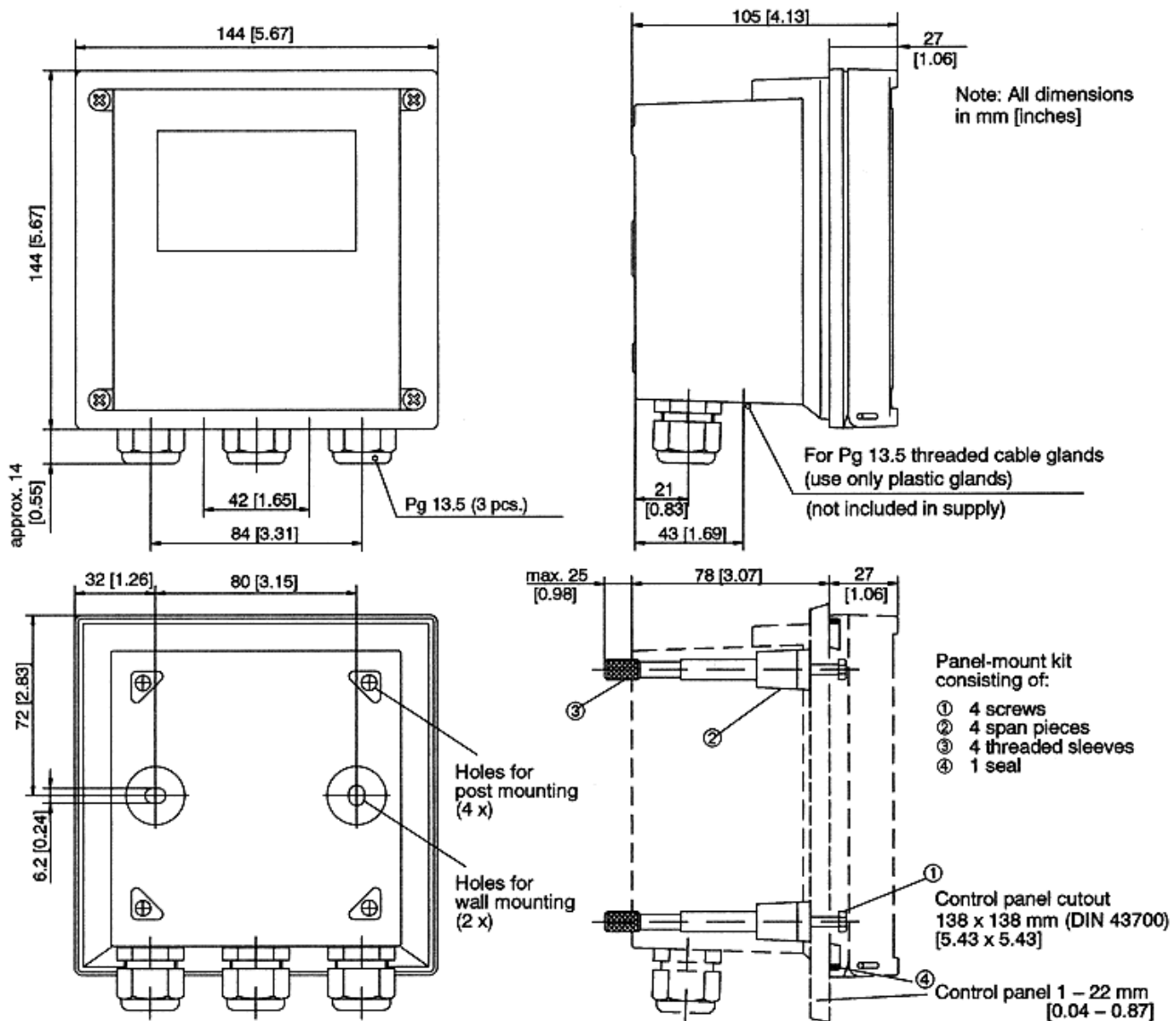

Figure 5—Dimension Drawing for APT4000 and P/N 51205990-001 Panel Mounting Kit

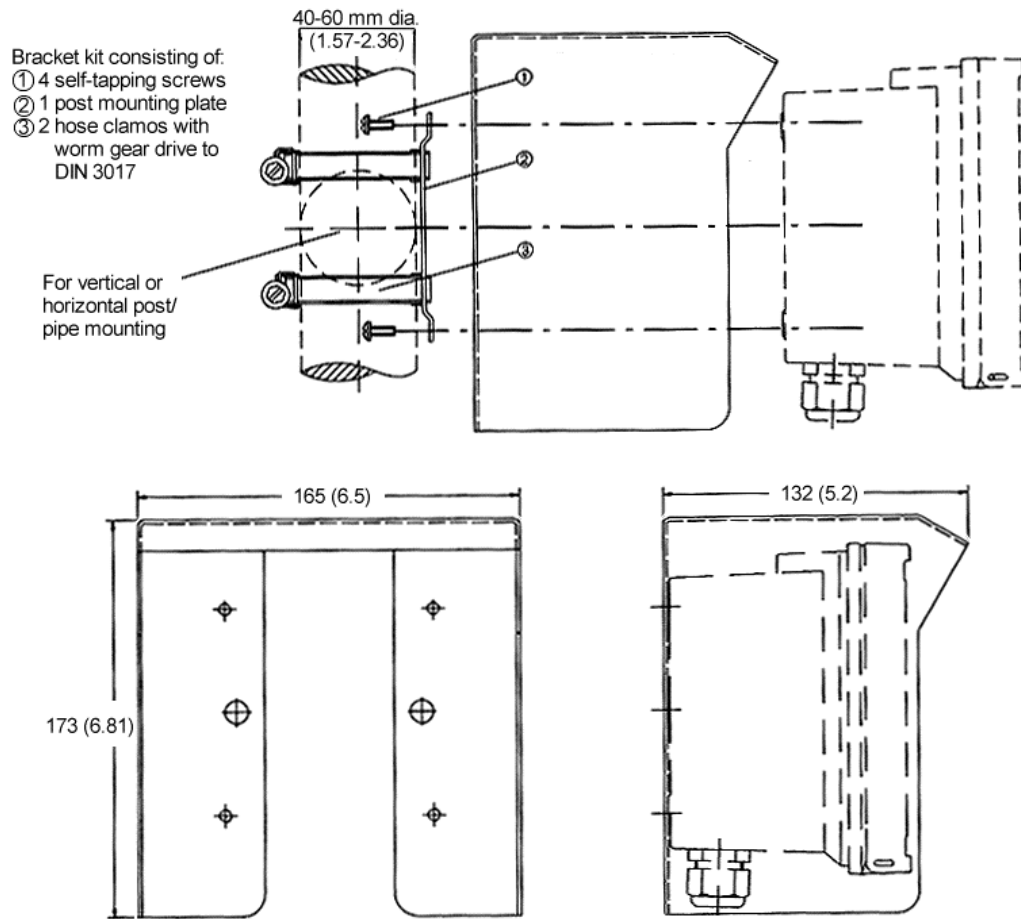

Figure 6—Dimension Drawing for APT4000 with Wall or Pipe Mounting

WARRANTY/REMEDY

Honeywell warrants goods of its manufacture as being free of defective materials and faulty workmanship. Contact your local sales office for warranty information. If warranted goods are returned to Honeywell during the period of coverage, Honeywell will repair or replace without charge those items it finds defective. The foregoing is Buyer's sole remedy and is **in lieu of all other warranties, expressed or implied, including those of merchantability and fitness for a particular purpose.** Specifications may change without notice. The information we supply is believed to be accurate and reliable as of this printing. However, we assume no responsibility for its use.

While we provide application assistance personally, through our literature and the Honeywell web site, it is up to the customer to determine the suitability of the product in the application.

For more information, contact Honeywell sales at (800) 343-0228.

Honeywell

Industrial Measurement and Control

Honeywell
1100 Virginia Drive
Fort Washington, PA 19034