

# APT4000 Series Toroidal Conductivity Transmitters

# Specification

## Overview

The Honeywell Analytical Process Transmitter (APT) 4000 Series transmitter continuously measures conductivity, chemical concentration and salinity in industrial processes within the chemical, food and dairy, pulp and paper, refinery, metals, and other industries.

The APT4000's NEMA 4X/IP65-rated enclosure is specifically designed to meet the measurement needs of Class I, Division 2 (non-incendive) and general-purpose areas. The transmitter can be used with Honeywell toroidal conductivity cells or electrically compatible sensors. The transmitter has a universal (20-253 V ac/dc, 45-65 Hz) power supply with one 4-20 mA output, two high/low alarm relays, a diagnostic relay, and a wash relay.

## Description

The Honeywell APT4000 series of transmitters offers the widest available selection of advanced features in a reliable and economical instrument.

### Reliability First

The advanced features of the APT4000 transmitter guarantee complete reliability. The APT4000 continuously monitors sensor and transmitter electronics and immediately displays diagnostic information at the onset of a problem. If an error or diagnostic is found, the transmitter will indicate the appropriate error code or pictograph (see Figure 2), blink a red LED and adjust the error current to 22 mA if desired. A manual loop-back check is available to test the integrity of the 4-20 mA output.

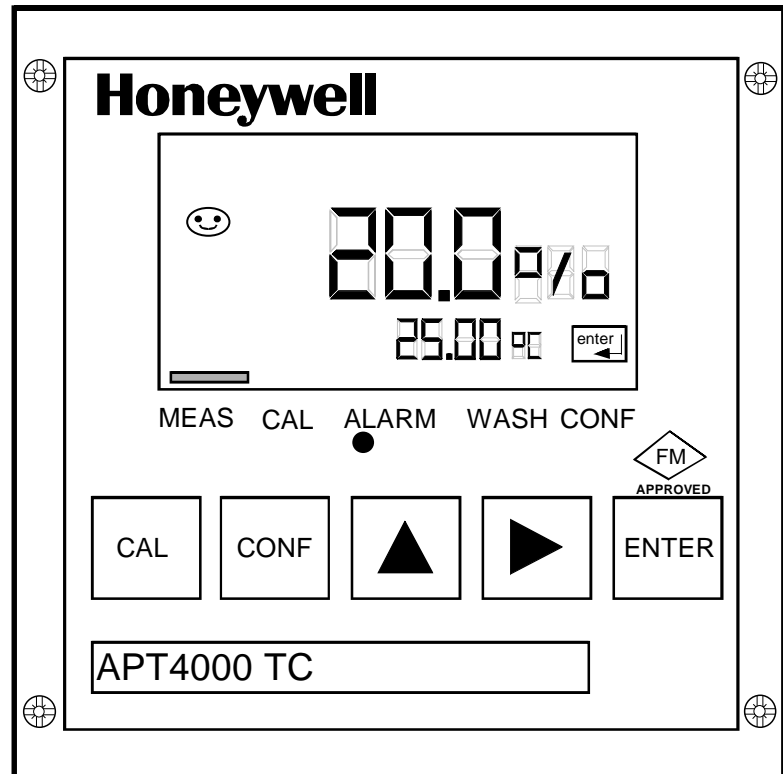

Figure 1—APT4000 TC Transmitter

### Quick Problem Assessment

The APT4000 has a large front display for quick recognition of process parameters and diagnostics even at a distance. Only the APT4000 employs *visual feedback* to quicken setup and maintenance times and to minimize errors made during calibrations. Visual feedback refers to pictograph type characters that appear on the display both to prompt and respond to operator and process changes.

Pictograph type characters also appear during problem conditions to report diagnostics for easy troubleshooting. There is even a Sensoface<sup>®</sup> pictograph that provides constant

feedback to the operator on whether or not there is a problem with the cell. These easily learned and recognized symbols make the APT4000 an easy-to-use instrument in any language.

### Foolproof Calibrations

Each Honeywell conductivity cell has unique measuring characteristics when shipped from the factory. It is possible that these characteristics will vary slightly depending upon the installation as well. For optimum accuracy, a single-point calibration in a known conductivity solution should be performed when a new cell is installed. Further calibration adjustments are also available for enhanced accuracy in special applications.

**Works with a Variety of Cells**

The inputs to the APT4000 Series include the Honeywell 5000TC toroidal conductivity cells, which feature a 1000 ohm Platinum RTD. In addition, a wide variety of other manufacturers' toroidal conductivity cells are compatible.

**Fully Certified**

The area certification for the ATP4000 TC is FM Class I, Div. 2, Groups A-D (non-incendive). In addition, each transmitter comes standard with CE.

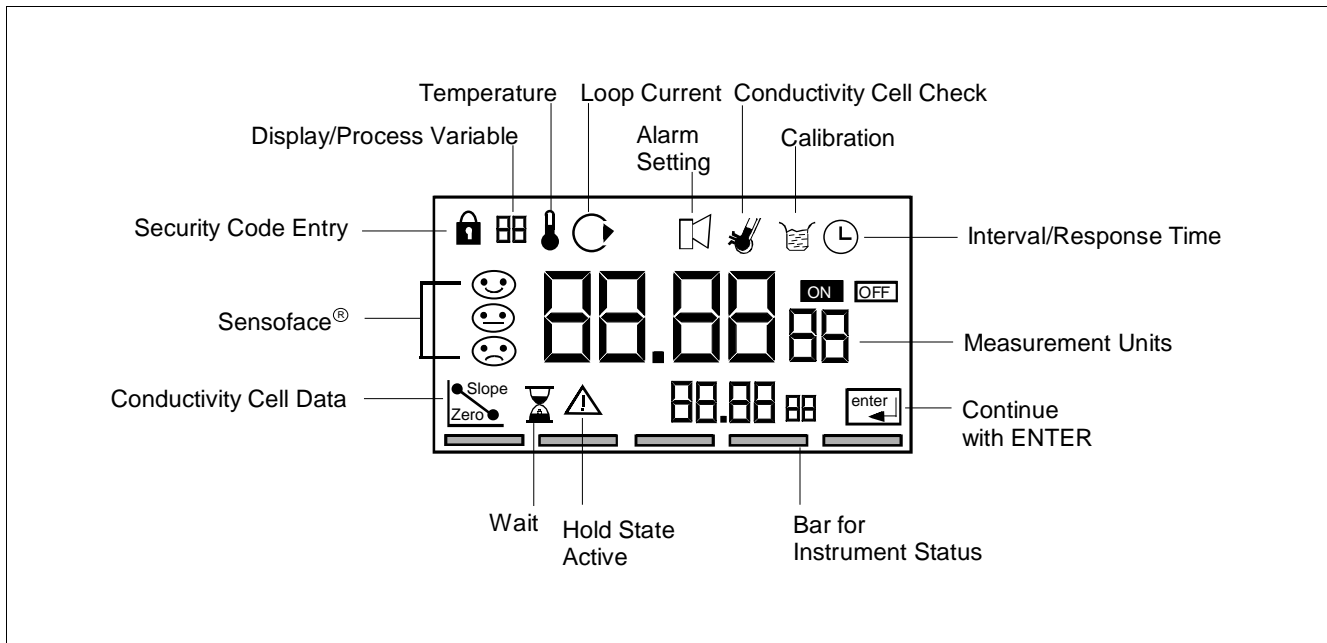

**Figure 2—APT4000 TC Display Features**

Features	Applications
<ul style="list-style-type: none"> <li>• Large display with easy-to-read 0.75 inch measured value</li> <li>• Simple operator interface with basic pictographs</li> <li>• Continuous diagnostics for monitoring calibration, cell health, and transmitter self-test</li> <li>• Manual loopback check for integrity of 4-20 mA output</li> <li>• Application in Class I, Division 2 or General Purpose areas</li> <li>• Wall, pipe or panel mounting</li> </ul>	<p>The APT4000 TC transmitter is designed to meet the measurement needs of a number of industries, including:</p> <ul style="list-style-type: none"> <li>• Chemical</li> <li>• Food and Dairy</li> <li>• Pulp and Paper</li> <li>• Refinery</li> <li>• Metals</li> </ul>
<ul style="list-style-type: none"> <li>• Easy installation with pre-assembled empty enclosure and plug-in terminals</li> <li>• Optical alarm signaling by blinking red LED</li> <li>• Integrated current source for simple checking of peripheral devices</li> <li>• Quick Response Time (less than five seconds per step change)</li> <li>• NEMA 4X, IP65 plastic enclosure</li> <li>• Dedicated high/low alarm relay</li> </ul>	

## Specifications

Conductivity Input			
<b>Conductivity Range</b>	00.00 to 99.99 mS/cm, 000.0 to 999.9 mS/cm, 0000 to 1999 mS/cm		
<b>Concentration Range</b>	<table style="width: 100%; border-collapse: collapse;"> <tr> <td style="width: 50%; vertical-align: top;">           NaCl 0-26.3 % by wt (0 °C)                  0-28.1 % by wt (100 °C)            HCl  0-17 % by wt (-20 °C)                  0-17 % by wt (50 °C)            NaOH 0-12 % by wt (0 °C)                  0-22 % by wt (100 °C)         </td> <td style="width: 50%; vertical-align: top;">           H<sub>2</sub>SO<sub>4</sub> 0-25 % by wt (-17 °C)                   0-35 % by wt (110 °C)            H<sub>2</sub>SO<sub>4</sub> 95-99 % by wt (-10 °C)                   95-99 % by wt (110 °C)            HNO<sub>3</sub>  0-28 % by wt (-20 °C)                   0-28 % by wt (50 °C)         </td> </tr> </table>	NaCl 0-26.3 % by wt (0 °C) 0-28.1 % by wt (100 °C) HCl  0-17 % by wt (-20 °C) 0-17 % by wt (50 °C) NaOH 0-12 % by wt (0 °C) 0-22 % by wt (100 °C)	H <sub>2</sub> SO <sub>4</sub> 0-25 % by wt (-17 °C) 0-35 % by wt (110 °C) H <sub>2</sub> SO <sub>4</sub> 95-99 % by wt (-10 °C) 95-99 % by wt (110 °C) HNO <sub>3</sub> 0-28 % by wt (-20 °C) 0-28 % by wt (50 °C)
NaCl 0-26.3 % by wt (0 °C) 0-28.1 % by wt (100 °C) HCl  0-17 % by wt (-20 °C) 0-17 % by wt (50 °C) NaOH 0-12 % by wt (0 °C) 0-22 % by wt (100 °C)	H <sub>2</sub> SO <sub>4</sub> 0-25 % by wt (-17 °C) 0-35 % by wt (110 °C) H <sub>2</sub> SO <sub>4</sub> 95-99 % by wt (-10 °C) 95-99 % by wt (110 °C) HNO <sub>3</sub> 0-28 % by wt (-20 °C) 0-28 % by wt (50 °C)		
<b>Salinity Range</b>	0.0 % to 45.0 % (0 °C to 35 °C)		
<b>Accuracy</b>	(1% of measured value) ± (0.02 mS/cm) ± (1 of least significant digit)		
<b>Step Change Response Time</b>	Less than 5 seconds		
Diagnostics			
<b>Sensocheck</b>	Polarization detection and monitoring of cable capacitance (can be switched off)		
<b>Sensor Standardization</b>	<ul style="list-style-type: none"> <li>- Entry of cell calibration factor with display of conductivity and temperature</li> <li>- Temperature probe adjustment</li> </ul>		
<b>Sensoface</b>	<ul style="list-style-type: none"> <li>- Provides information on the electrode state via Sensocheck</li> <li>- Monitors asymmetry potential, slope, and response time during calibration</li> </ul>		
Temperature Input			
<b>Range</b>	Pt100/1000 Ω RTD, 100 K Ω Thermistor:   -20.0 °C to +150.0 °C (+4 °F to +302 °F)		
<b>Resolution</b>	Pt100/1000 Ω RTD, 100 K Ω Thermistor:   0.1 °C or 1 °F		
<b>Accuracy</b>	Pt1000 Ω RTD:                 ± 0.5 °C Pt100 Ω RTD:                 ± 1 °C 100K Ω Thermistor:         ± 0.5 °C below 100 °C; less than 1 °C above 100 °C		
<b>Temperature Compensation</b>	Automatic Compensation using Pt 100 Ω/1000 Ω RTD or 100 K Ω Thermistor, or manual adjust		
<b>Display</b>	LCD display 76 mm x 48 mm (3" x 1-7/8") dimensions, 7-segment <i>Cond Value:</i> character height 17 mm (0.66"), meas. symbol 10 mm (0.4") <i>Temperature:</i> character height 10 mm (0.4"), meas. symbol 7 mm (0.33") Sensoface with three states, 5 status bars, 16 pictographs / symbols, Red Alarm LED Security protection with four-digit mode codes to access calibration and configuration options		
Calibration			
<b>Sensor Standardization Options</b>	<i>Calibration by Cell Factor:</i> 0.100 to 19.99 <i>Calibration by Transfer Ratio:</i> 1.00 to 99.99 <i>Zero Point Air Calibration:</i> ± 0.5 mS/cm offset (low conductivity measurements) Calibration by Standardizing Solution		
<b>Test Mode</b>	Resistance measurement by use of fixed resistor temporarily inserted through the sensor bore.		
Area Certifications / Compliances			
<b>Approvals</b>	FM Class I, Div. 2, Groups A-D		
<b>Data Retention</b>	Parameters and calibration data > 10 years (EEPROM)		
<b>RFI Suppression / Immunity to ESD</b>	To EN 50 081-1 and EN 50 081-2		
<b>Ambient Conditions</b>	<i>Operation/Environmental temperature:</i> (T4) -20 °C to +55 °C (-4 °F to +131 °F) (T6) -20 °C to +40 °C (-4 °F to +104 °F)  <i>Transport and Storage temperature:</i> -20 °C to +70 °C (-4 °F to +158 °F)		

<b>Supply/Output</b>	
<b>Output Current</b>	0 mA or 4 mA to 20 mA current loop, 10 V floating
<b>Supply Voltage</b>	20 V to 253 V ac/dc, 45 Hz to 65 Hz, 2 VA / 1.5 W
<b>Overrange</b>	22 mA for error messages
<b>Current Error</b>	< 0.3 % of current value +0.05 mA
<b>Current Source</b>	3.80 mA to 22.0 mA
<b>Output Characteristic</b>	Linear or Logarithmic
<b>Minimum Span</b>	<i>LIN</i> : 5 % of the selected range <i>LOG</i> : 1 decade
<b>Alarms/Relays</b>	
<b>Contacts</b>	<i>Alarm minimum</i> : SPST N/O (Hysteresis 0.2 % of measured range) <i>Alarm maximum</i> : SPST N/O (Hysteresis 0.2 % of measured range) <i>Diagnostic contact</i> : SPST N/C <i>Wash contact</i> : SPST N/O
<b>Maximal Current/Voltage</b>	<i>AC</i> : < 250 V / < 3A / < 750 VA <i>DC</i> : < 30 V / < 3A / < 90 W
<b>Physical</b>	
<b>Enclosure</b>	Plastic enclosure made of PBT (polybutylene terephthalate) bluish-gray RAL 7031
<b>Mounting</b>	Wall, Pipe, or Panel Mount
<b>Dimensions</b>	<i>Height</i> : 144 mm (5.67") <i>Width</i> : 144 mm (5.67") <i>Depth</i> : 105 mm (4.13")
<b>Protection</b>	NEMA 4X, IP65
<b>Cable glands</b>	3 breakthroughs for Pg 13.5 2 breakthroughs for NPT 1/2" or Rigid metallic conduit
<b>Weight</b>	Approximately 1 kg (2.2 lb.)

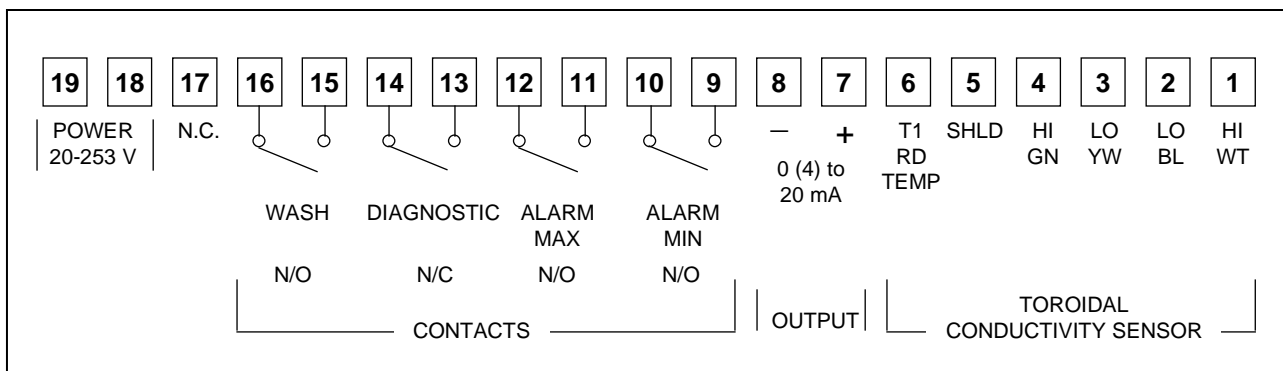

Figure 3—APT4000TC Terminal Assignments

## Model Selection Guide

Reference 51-52-16-73

### Instructions

- APT4000 Transmitter Offers:
    - Power Requirements - Universal, 20 to 253V AC/DC 45 to 65 Hz
    - Standard - NEMA 4X, IP65
    - Standard Approvals:
      - General Purpose; also FM Class I, Div 2, Groups A-D
      - Standard - All models CE Compliant
      - High/Low Alarm Relays
    - Three mounting types: **(must be ordered separately)**
      - Panel Mount Kit
      - Pipe/Wall Mount Kit
      - Protective Hood (requires Pipe/Wall Mount Kit)
  - Select the desired key number. The arrow to the right marks the selection available.
  - Make one selection from Tables using the column below the proper arrow.  
A dot (•) denotes unrestricted availability.
- Key Number**      **I**

-----	-	I
-------	---	---

KEY NUMBER	Selection	Availability		
<b>Description of Measurement Type</b>				
pH/ORP	APT 4000 PH	↓		
Toroidal (Electrodeless) Conductivity	APT 4000 TC		↓	
Contacting Conductivity	APT 4000 CC			↓

**TABLE I - Optional Equipment**

User's Manual	English	E _ _	•	•	•
Future		_ 0 _	•	•	•
Future		_ _ 0	•	•	•

NOTE: Mounting kit not included with APT4000.

Accessory Parts	Part Number
Mounting Kits:	
Panel Mounting Kit	51205990-001
Pipe/Wall Mounting Kit	51205988-001
Protective Hood (requires pipe/wall kit)	51205989-001
Instruction Manual - pH	70-82-25-103
Instruction Manual - Toroidal (Electrodeless) Conductivity	70-82-25-104
Instruction Manual - Contacting Conductivity	70-82-25-105

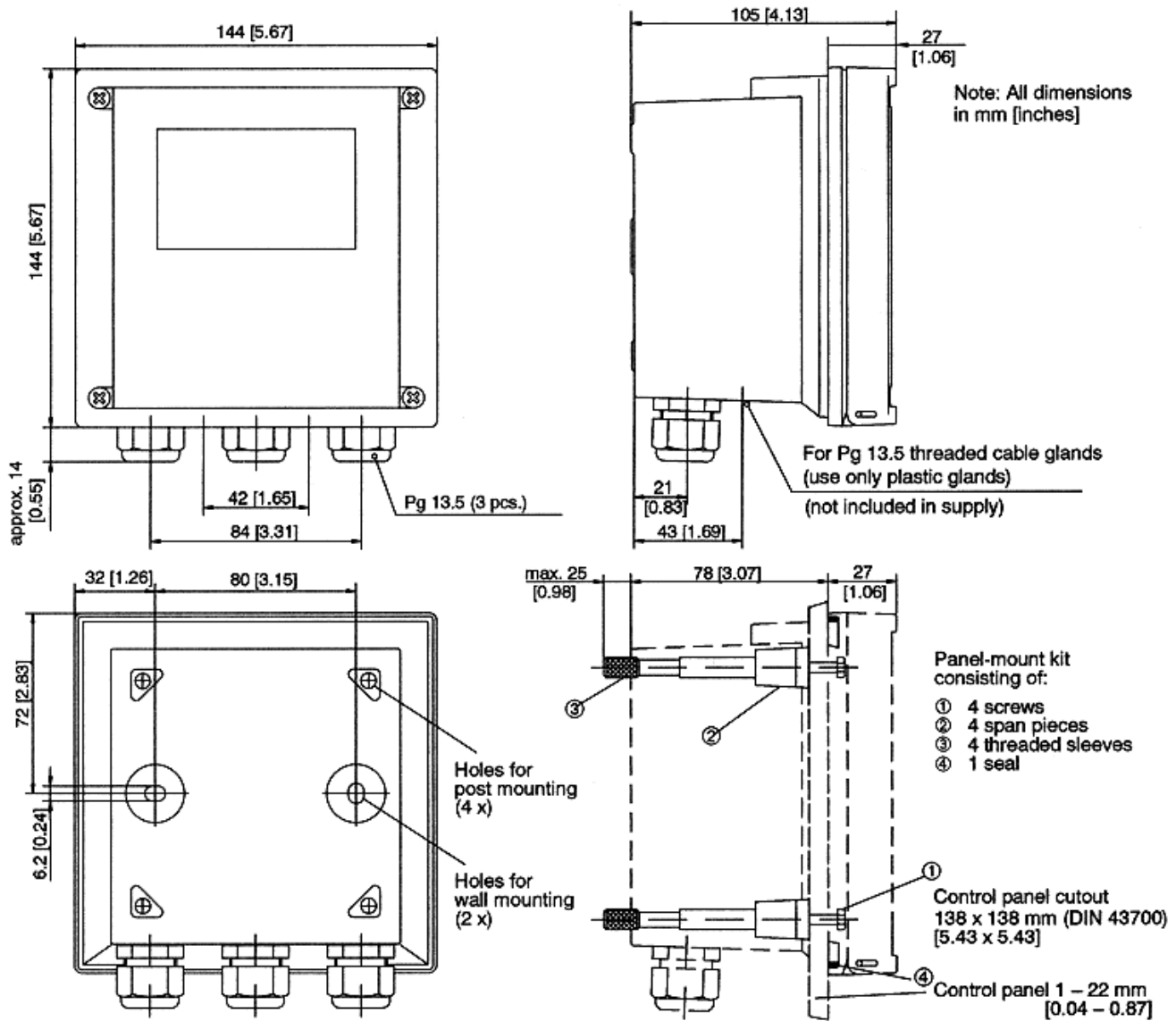

Figure 4—Dimension Drawing for APT4000 and P/N 5120590-001 panel mounting kit

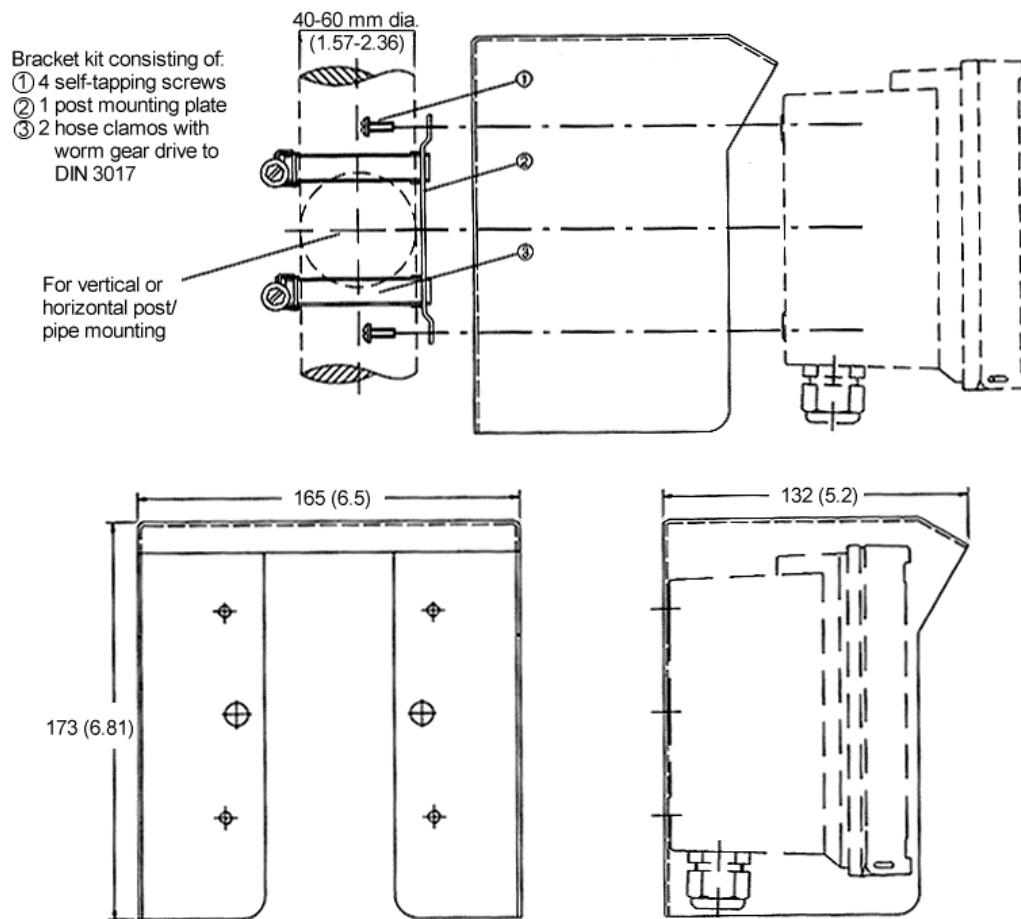

Figure 5—Dimension Drawing for APT4000 with Wall or Pipe Mounting

## WARRANTY/REMEDY

Honeywell warrants goods of its manufacture as being free of defective materials and faulty workmanship. Contact your local sales office for warranty information. If warranted goods are returned to Honeywell during the period of coverage, Honeywell will repair or replace without charge those items it finds defective. The foregoing is Buyer's sole remedy and is **in lieu of all other warranties, expressed or implied, including those of merchantability and fitness for a particular purpose.** Specifications may change without notice. The information we supply is believed to be accurate and reliable as of this printing. However, we assume no responsibility for its use.

While we provide application assistance personally, through our literature and the Honeywell web site, it is up to the customer to determine the suitability of the product in the application.

For more information, contact Honeywell sales at (800) 343-0228.

---

# Honeywell

**Sensing and Control**  
Honeywell  
11 West Spring Street  
Freeport, IL 61032