

Honeywell

APT2000 Series 2-Wire pH Transmitters User Manual

70-82-25-92
MU11-6245
Revision 1 – 09/00



Copyright, Notices, and Trademarks

© Copyright 1999 by Honeywell Inc. Revision 1 – 09/00	
While this information is presented in good faith and believed to be accurate, Honeywell disclaims the implied warranties of merchantability and fitness for a particular purpose and makes no express warranties except as may be stated in its written agreement with and for its customer.	
In no event is Honeywell liable to anyone for any indirect, special or consequential damages. The information and specifications in this document are subject to change without notice.	
Honeywell Industrial Automation and Control Automation College 1100 Virginia Drive Ft. Washington, PA. 19034	Honeywell S.A. Espace Industriel Nord rue André Durouchez 80084 Amiens Cedex 2 France

Contacts

The following list identifies important contacts within Honeywell.

Organization	Telephone	Address
Honeywell Technical Assistance Center	1-800-423-9883 (USA and Canada)	1100 Virginia Avenue Fort Washington, PA 19034
Honeywell S.A.	33-3-22-54-56-56 (Europe)	80084 Amiens Cedex 2 France

Safety Precautions

Be sure to read and observe the following requirements!

Warning  The APT2000PH-0(H)-00 Transmitter is approved for operation in safe areas and hazardous locations DIV 2 (USA/Canada) only.
Before connecting the Transmitter to a power supply unit, make sure that this is not capable of outputting more than 40 Vdc (safe areas) / 30 Vdc (DIV 2).

Warning  The APT 2000PH-0(H)-IS Transmitter is approved for operation in hazardous locations DIV 1 (USA/Canada) / Zone 1 (Europe).
Before connecting the Transmitter to a power supply unit, make sure that this is an associated apparatus.

Warning  The measuring inputs of the APT 2000PH-0(H)-IS Transmitter may be led into Zone 0 (Europe).
However, be sure to observe the national regulations concerning Zone 0 applications.
The Transmitter itself is not approved for operation in Zone 0!

Whenever it is likely that the protection has been impaired, the Transmitter shall be made inoperative and secured against unintended operation.

The protection is likely to be impaired if, for example:

- the Transmitter shows visible damage
- the Transmitter fails to perform the intended measurements
- after prolonged storage at temperatures above 70 °C
- after severe transport stresses

Before recommissioning the Transmitter, a professional routine test must be performed. This test should be carried out at our factory.

The Transmitter shall not be used in a manner not specified by this manual.

Information on this Instruction Manual

ITALICS are used for texts which appear in the Transmitter display.

Bold print is used to represent keys, e.g. **CAL**.

CAL

Keys for which the functions are explained are frequently shown in the left-hand column.

Note



Notes provide important information that should be strictly followed when using the unit.

Warning



Warning means that the instructions given must always be followed for your own safety. Failure to follow these instructions may result in injuries.

Mode Codes

With **CONF/CAL** and input of a mode code you can activate one of the following modes:

CONF

CONF, 0000: Error info
CONF, 1200: Configuration
CONF, 5555: Current source

CAL

CAL, 0000: Cal info
CAL, 1001: Nominal zero adjustment
CAL, 1015: Temperature probe adjustment
CAL, 1100: Calibration
CAL, 2222: Test mode (display electrode potential)

Contents

Safety Precautions	3	Outputs	21
Information on this Instruction Manual ...	4	Configuration	22
Mode Codes	4	Calibration	24
1 Assembly	6	Measurement	31
Package Contents and Unpacking ...	6	4 Diagnostics, Maintenance and Cleaning	32
Assembly	6	Sensoface®, Sensocheck®	32
2 Installation, Connection and Commissioning	10	Error Messages	33
Proper Use	10	Calibration Error Messages	35
Overview of the pH/ORP Transmitter ..	11	Diagnostics Functions	36
Terminal Assignment	12	Maintenance and Cleaning	37
Installation and Commissioning	13	5 Annex	38
Wiring Diagrams (pH)	14	Product Line	38
Wiring Diagrams (ORP)	17	Specifications	39
3 Operation	18	Type Examination Certificate	43
User Interface	18	Control / Installation drawing	46
Display	19	Buffer Charts	48
Keypad	19	Glossary	50
Safety Functions	20	Index	53

1 Assembly

Package Contents and Unpacking

Unpack the instrument carefully and check the shipment for transport damage and completeness. The package contains:

- Front unit of APT2000PH Transmitter
- Lower case
- Short instruction sheet
- This instruction manual
- HART Command Specification
(only for Model APT2000PH-H..)

– Bag containing:

- | | | | |
|---|---------------------|---|---------------------------|
| ① | 2 plastic plugs | ⑦ | 1 hinge pin |
| ② | 5 hexagon nuts | ⑧ | 3 cable ties |
| ③ | 3 Pg cable glands | ⑨ | 3 filler plugs |
| ④ | 1 Pg rubber reducer | ⑩ | 3 sealing rings |
| ⑤ | 1 Pg plugs | ⑪ | 1 metal plate for conduit |
| ⑥ | 4 set screws | ⑫ | 1 jumper |

Assembly

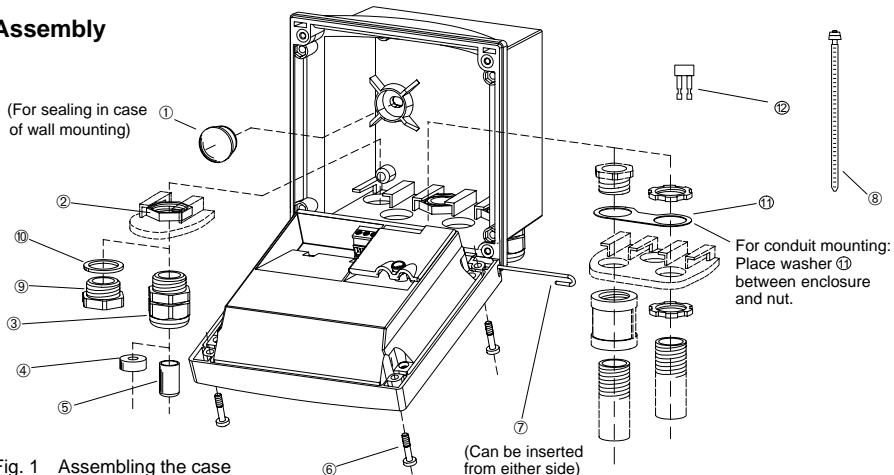

Fig. 1 Assembling the case

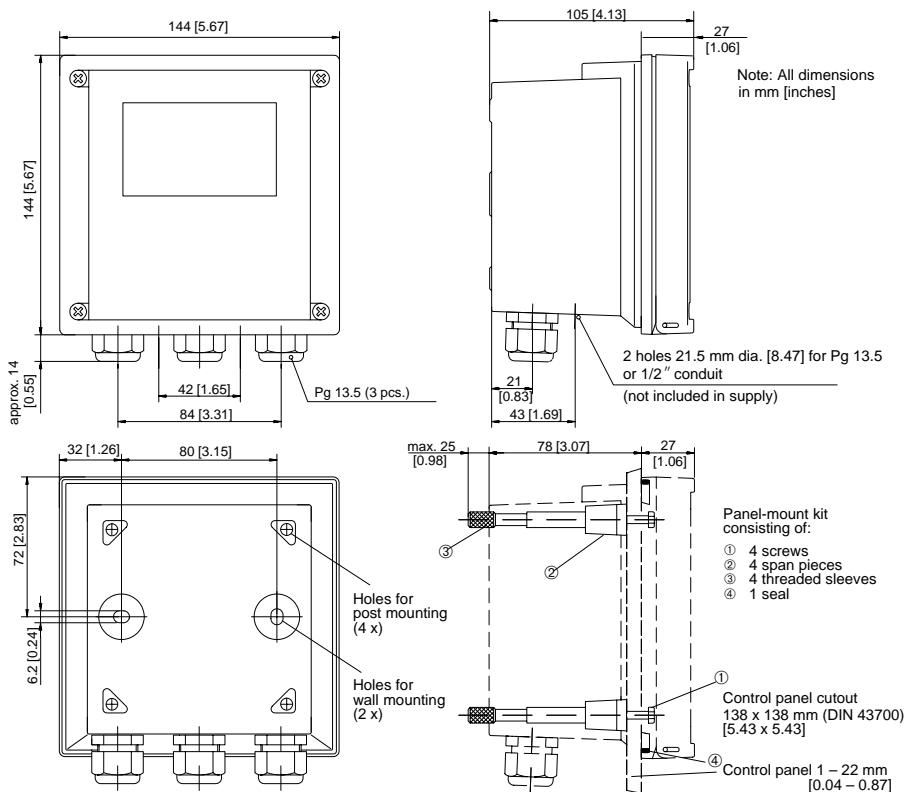

Fig. 2 Dimension drawing for Transmitter, mounting diagram and P/N 51205990-001 panel-mount kit

Pipe-mount kit
consisting of:

- ① 4 self-tapping screws
- ② 1 pipe mounting plate
- ③ 2 hose clamps with worm gear drive to DIN 3017

For vertical or
horizontal post/
pipe mounting

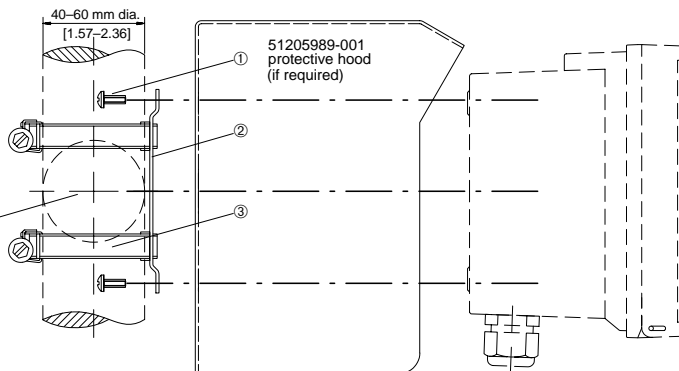

Fig. 3 P/N 51205988-001 pipe-mount kit

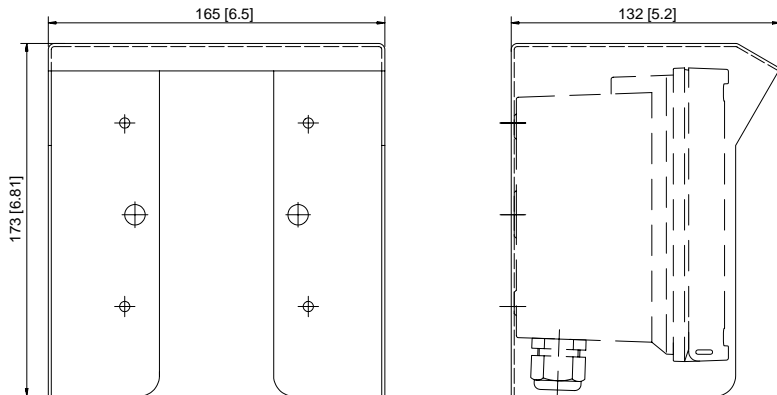

Fig. 4 P/N 51205989-001 protective hood for wall and pipe mounting

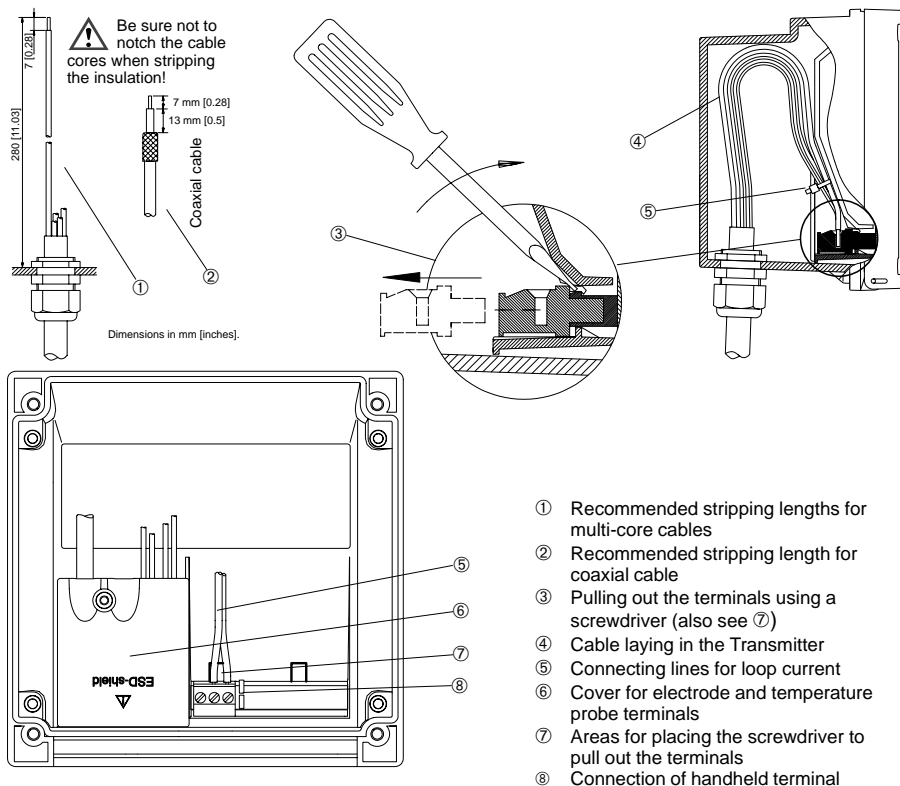

Fig. 5 Installation information

2 Installation, Connection and Commissioning

Proper Use

The APT2000PH Transmitter is used for pH and temperature measurement in industry, the environment, food processing and waste-water field. It can be either field-mounted or fixed into a control panel.

Warning



The APT2000PH-0(H)-00 Transmitter is approved for operation in safe areas and hazardous locations DIV 2 (USA/Canada only). Before connecting the Transmitter to a power supply unit, make sure that this is not capable of outputting more than 40 Vdc (safe areas) / 30 Vdc (DIV 2).

Warning



The APT2000PH-0(H)-IS Transmitter is approved for operation in hazardous locations DIV 1 (USA/Canada) / Zone 1 (Europe). Before connecting the Transmitter to a power supply unit, make sure that this is an associated apparatus.

Warning



The measuring inputs of the APT 2000PH-0(H)-IS Transmitter may be led into Zone 0 (Europe). However, be sure to observe the national regulations concerning Zone 0 applications. The Transmitter itself is not approved for operation in Zone 0!

Overview of the pH/ORP Transmitter

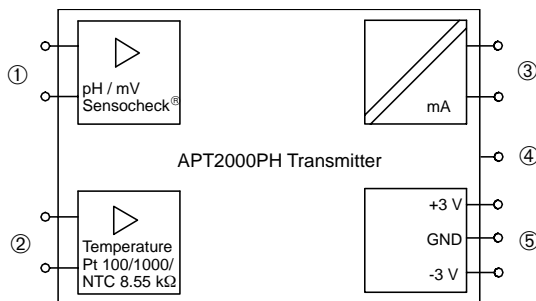

Fig. 6 System functions of APT2000PH Transmitter

- ① Inputs for pH electrodes (Durafet® / glass and reference electrode)
- ② Input for temperature probe
- ③ Current loop 4 – 20 mA, either for pH or mV, transports power to and output signal from the Transmitter, with APT2000PH-H-.. Transmitter also for HART® communication
- ④ Equipotential bonding (only with APT2000PH-0(H)-IS Transmitter) (also see Pg. 51)
- ⑤ Power supply for Durafet® adapter

Terminal Assignment

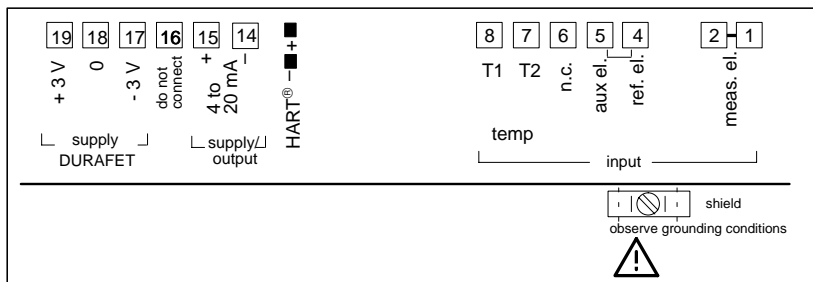

Fig. 7 Terminal assignment of APT2000PH-H-00 Transmitter
Class 1, Div 2, Group A, B, C, D, T4

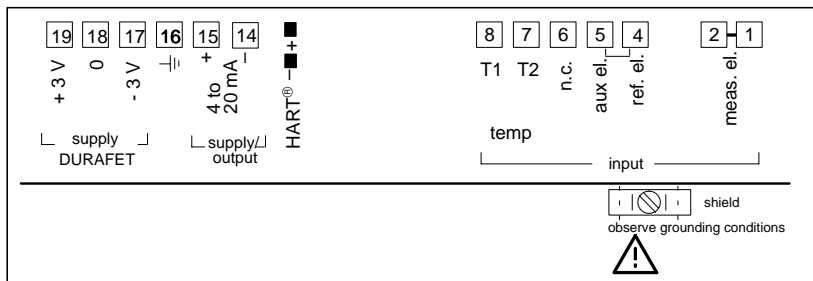

Fig. 8 Terminal assignment of APT2000PH-H-IS Transmitter
IS, Class I, Div 1, Group A, B, C, D, T4
II 2(1) G EEx ib [ia] IIC T6

Installation and Commissioning

Warning



Installation and commissioning of the Transmitter may only be carried out in accordance with this instruction manual and per applicable local and national codes. Be sure to observe the technical specifications and input ratings.

Warning



Before connecting the APT2000PH-0(H)-00 Transmitter to a power supply unit, make sure that this is not capable of outputting more than 40 Vdc (safe areas) / 30 Vdc (DIV 2).

Warning



Before connecting the APT2000PH-0(H)-IS Transmitter to a power supply unit, make sure that this is an associated apparatus (for input ratings refer to the Control Drawing or the annex of the EC Type Examination Certificate).

Warning



Do not use alternating current or mains power supply!

Warning



When commissioning, a *complete configuration* must be carried out.

For easier installation, the terminal strips are of a plug-in design. The terminals are suitable for single wires and flexible leads up to 2.5 mm² (AWG 14) (see Pg. 9).

See Pg. 14 and following for connection examples.

Warning



Do not use cable clamp (shield) for reference electrode connection when auxiliary electrode (solution ground) is in use.

Wiring Diagrams (pH)

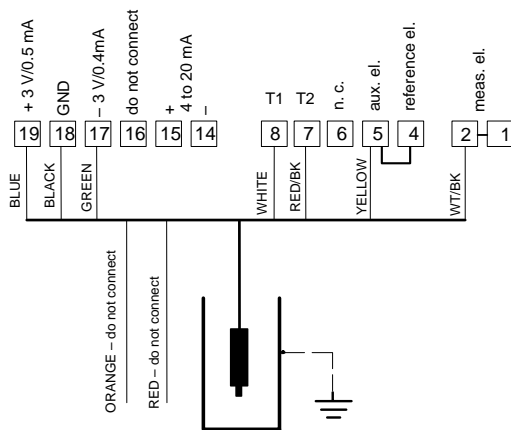

Fig. 9 pH measurement with Durafet® combination electrode, with integrated temperature measurement (without Sensoscheck®)

Note



ORANGE and RED wires are not typically connected. These should be clipped and electrically sealed to avoid possible contact with other conductors.

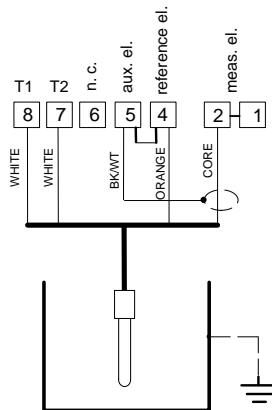

Fig. 10 pH measurement with Meredian® combination electrode, with integrated temperature measurement and Sensoscheck® for the glass electrode

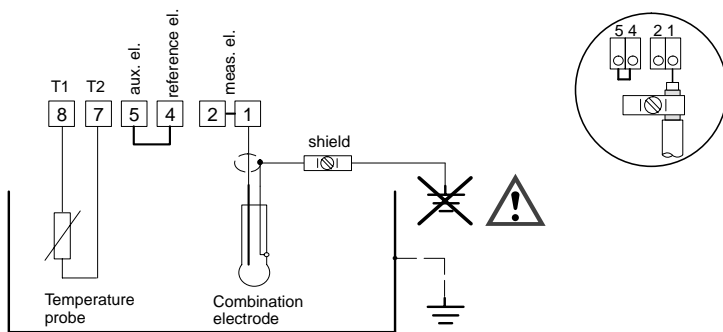

Fig. 11 pH measurement with other manufacturer's combination electrode, with separate temperature measurement and Sensocheck® for the glass electrode

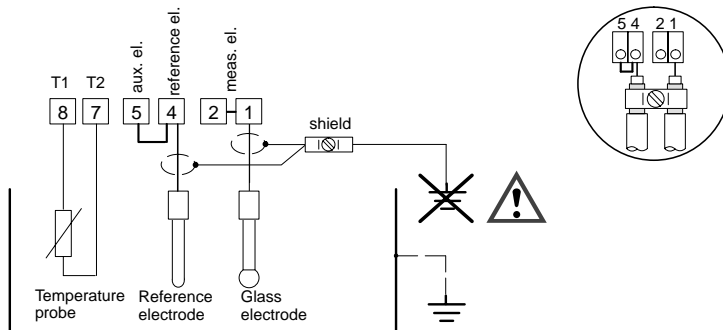

Fig. 12 pH measurement with separate glass and reference electrode, with separate temperature measurement and Sensocheck® for the glass electrode

Wiring Diagrams (ORP)

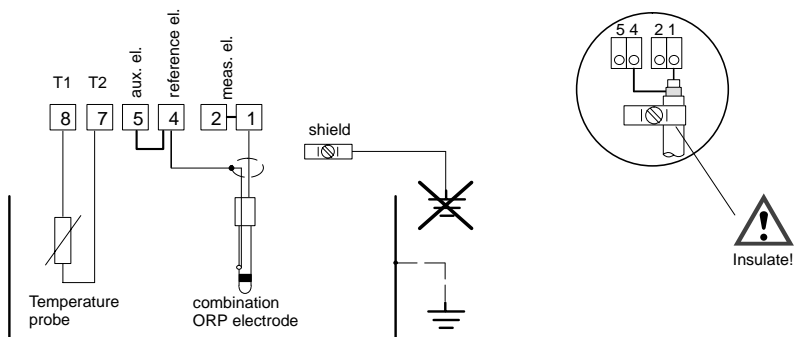

Fig. 13 ORP measurement with separate combination ORP electrode and temperature probe

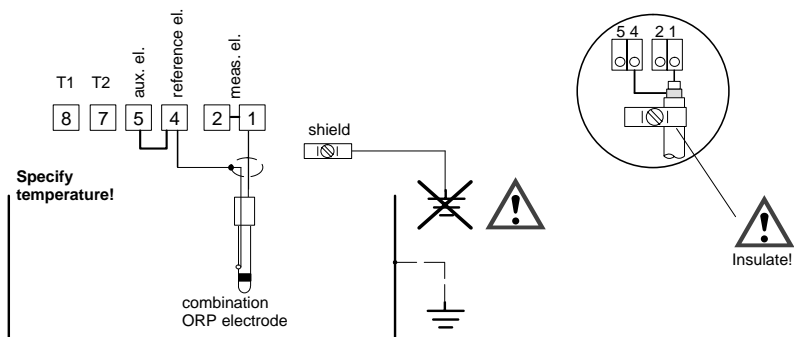

Fig. 14 ORP measurement with combination ORP electrode without temperature probe

3 Operation

User Interface

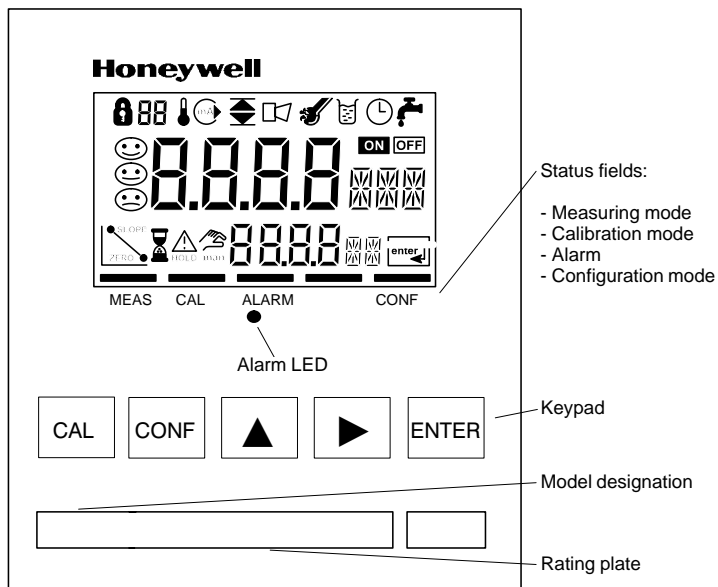

Fig. 15 Front view of Transmitter

Display

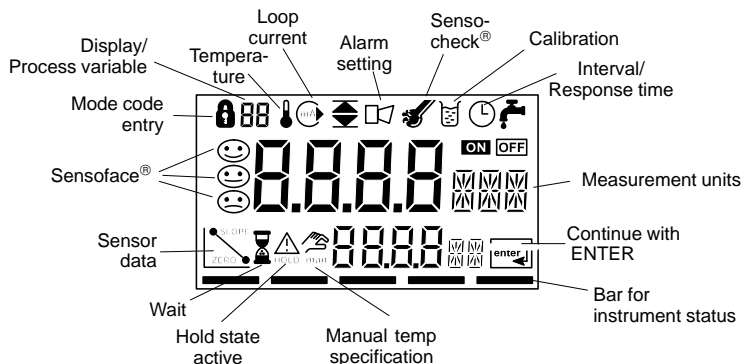

Fig. 16 Transmitter display

Keypad



Start, end calibration



Start, end configuration



Select digit position
(selected position flashes)



Change digit



Prompt in display:
continue in program sequence,
Configuration: Confirm entries, next
configuration step,
Measuring mode: Display output
current



Cal info, display asymmetry poten-
tial (zero) and slope (see Pg. 31)



Error info, display last output error
message (see Pg. 31)

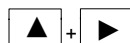

Start GainCheck® manual unit
self-test (see Pg. 20)

Safety Functions

Sensoface[®] electrode monitoring



Sensoface[®] provides information on the electrode state. The asymmetry potential, slope and response time during calibration are evaluated. **Sensocheck[®]** continuously monitors the glass and reference electrode.

Note



When measuring with a Durafet[®] electrode, Sensocheck[®] is not active.

For more detailed information, see chapter “Diagnostic, Maintenance and Cleaning” (Pg. 32).

GainCheck[®] manual self-test

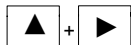

Simultaneously pressing ▲ and ► starts the manual unit self-test.

A display test is carried out, the software version is displayed and the memory and measured value transmission are checked.

Automatic self-test

The automatic unit self-test checks the memory and the measured-value transmission. It runs automatically in the background at fixed intervals.

Outputs

Loop current

The current loop transports power to and output signals from the Transmitter. The current is controlled by the process variable selected in the configuration. The current beginning and end can be set to any desired value.

To check connected peripherals (e.g. limit switches, controllers), the loop current can be manually specified (see Pg. 36).

HART communication

The APT2000PH-H-.. Transmitter can be remote controlled via HART communication. It can be configured using a handheld terminal or from the control room. Measured values, messages and device identification can be downloaded at any time. This allows easy integration also in fully automatic process sequences.

For more detailed information, refer to the HART® Command Specification.

Alarm

During an error message the alarm LED flashes. Alarm response time is permanently set to 10 sec.

Error messages can also be signaled with a 22 mA signal via the loop current (see Configuration, Pg. 23).

Configuration

Here the basic settings of the Transmitter are carried out. Symbols show which parameter is being configured.



Activate with **CONF**
change parameter with **▲** and **▶**,
confirm/continue with **ENTER**,
end configuration with **CONF**



Mode code "1200"













During configuration the loop current is frozen.

HOLD

When the configuration mode is exited, the Transmitter remains in the Hold state for safety reasons. This prevents undesirable reactions of the connected peripherals (e.g. limit switches, controllers) due to incorrect settings. The measured value and *Hold* are displayed alternately. Now you can check whether the measured value is plausible and specifically end the Hold state with **ENTER**. After a relax time of 20 sec (for measured value stabilization) the Hold state is ended.

Configuration parameters

Before attempting any changes refer to the parameter setup list shown below. This table presents the possible options and the factory settings.

Pictograph	Parameter	Choices	Factory Setting
	Process variable (when changed, complete configuration required)	pH 0.00 to 14.00 ORP -1,500 to +1,500 mV	pH
	Electrode type	Durafet (FEt EL) Glass (GLAS EL)	FEt EL
	Temperature display / detection	Auto °C / °F automatic detection  °C / °F manual specification	Auto °C
	Temperature probe	Pt 100 / Pt 1000 / NTC 8.55 kΩ	NTC
	Current beginning, current end	4 mA, 0 to 14 pH, 20 mA, 0 to 14 pH	4 mA, 0 pH 20 mA, 14 pH
	Hold state	Last: Last loop current Fix: Specified loop current	Last
	22 mA signal for error message	On / OFF	OFF
	Sensocheck [®] (sensor diagnostics) (not for Durafet [®])	On / OFF	OFF
	Calibration mode: Automatic with Calimatic [®] Manual	BUF -00– Knick techn. buffers BUF -01– Mettler Toledo techn. buffers BUF -02– Merck/Riedel de Haën BUF -03– Ciba (94) BUF -04– NIST technical buffers BUF -05– NIST standard buffers BUF -06– HACH MAN Manual buffer entry DAT Data entry of premeasured values	BUF -04–
	Calibration timer interval	xxxx hours	0000 (OFF)

Configuration is circular. To stop, press **CONF**.

Calibration

Adjustment of nominal zero

CAL 1001

When measuring with a Durafet® electrode, the nominal zero point must be adjusted each time a new electrode is connected. This is important if you want to obtain reliable Sensoface® messages.

The Sensoface® messages issued during all further calibrations are based on this basic calibration.



Activate calibration by pressing the **CAL** key.

Using the ▲, ► keys enter mode code "1001" and then press **ENTER**.



7.00 PH

Place the electrode in a pH 7.00 buffer.

Using the ▲, ► keys enter the correct pH value in the range pH 6.50 to 7.50 for the actual temperature (see buffer chart).



Press **ENTER** to confirm.

Note



If the zero offset of the electrode is too large (more than ± 200 mV), the CAL ERR error message will be generated. In that case the electrode cannot be calibrated.

0 mV

Stability check:
measured mV value is displayed

Note



The stability check can be aborted with **CAL**. However, accuracy of the calibration will be compromised.

98.0 / 0.0
mV

At the end of the adjustment the slope and asymmetry potential (based on 25 °C) of the electrode are displayed. These are not the calibrated values of the electrode! These must still be determined using a complete 2-point calibration (CAL 1100).



The procedure is ended with **ENTER**. The Transmitter remains in the Hold state. You can now re-install the electrode and end the Hold state with **ENTER**. After a relax time of 20 sec (for measured value stabilization) the Transmitter returns to measuring mode.

Note



After having adjusted the nominal zero point, be sure to calibrate the electrode following one of the procedures as described on the next pages.

Electrode standardization (CAL 1100)

You can conduct either a one- or a two-point calibration. The calibration can be carried out with the Calimatic® automatic buffer recognition, with manual buffer input or by entering pre-measured electrode data (selected in Conf mode).



Activate with **CAL**.
confirm/continue with **ENTER**.
abort with **CAL → ENTER**



During calibration the loop current is frozen. The Transmitter is in the Hold state.

When the calibration mode is exited, the Transmitter remains in the Hold state for safety reasons. This prevents undesirable reactions of the connected peripherals (e.g. limit switches, controllers) due to incorrect settings. The measured value and *Hold* are displayed alternately. Now you can check whether the measured value is plausible and specifically end the Hold state with **ENTER** or repeat calibration with **CAL**. If you end the Hold state, the Transmitter will return to measuring mode after a relax time of 20 sec (for measured value stabilization).

Automatic calibration with Calimatic® BUF and automatic calibration temp detection

(if selected in Conf mode)

Note



The Transmitter can only operate properly when the buffer solutions used correspond to the configured buffer set. Other buffer solutions, even those with the same nominal values, may demonstrate a different temperature behavior. This leads to measurement errors.



Activate calibration by pressing the **CAL** key.

Using the ▲, ► keys enter mode code "1100" and then press **ENTER**.



CAL 1

Remove the electrode and temperature probe and immerse them in the first buffer solution; it does not matter which buffer solution is taken first.



Start calibration with **ENTER**.



While the hour glass flashes, the electrode and temperature probe remain in the first buffer solution.

Note



The response time of electrode and temperature probe is considerably reduced if the electrode is first moved about in the buffer solution and then held still. Stirring provides stable values faster.

-. - PH

Buffer recognition

7.00 PH

Nominal buffer value is displayed

0 mV'

Stability check:
measured mV value is displayed

Note



The stability check can be aborted with **CAL**. However, accuracy of the calibration will be compromised.

CAL 2

Calibration with the first buffer is completed. Remove the electrode and temperature probe from the first buffer solution and rinse off both thoroughly.

- If you would like to carry out a one-point calibration, end the calibration now with **CAL**. The Transmitter then shows the newly determined asymmetry potential in the lower display and the old slope in the main display.
- If you would like to carry out a two-point calibration, immerse the electrode and the temperature probe in the second buffer solution. Now start the calibration again with **ENTER**. The calibration process runs again as for the first buffer.

98 □ / □
1 mV

At the end of calibration the slope and asymmetry potential (based on 25 °C) of the electrode are displayed. Calibration is ended with **ENTER**. The Transmitter remains in the Hold state. You can now reinstall the electrode and temperature probe and end the Hold state with **ENTER**. After a relax time of 20 sec (for measured value stabilization) the Transmitter returns to measuring mode.

Manual calibration MAN with automatic calibration temp detection

(if selected in Conf mode)

For calibration with manual buffer specification, you must enter the pH value of the buffer solution used in the Transmitter **for the actual temperature**. This enables calibration with any desired buffer solution.



Activate calibration by pressing the **CAL** key. Using the ▲, ► keys enter mode code "1100" and then press **ENTER**.



Remove the electrode and temperature probe and immerse them in the first buffer solution; it does not matter which buffer solution is taken first. Confirm with **ENTER**.



Set the pH value of your buffer solution for the actual temperature with ▲ and ►. Start calibration with **ENTER**.

Note



The response time of electrode and temperature probe is considerably reduced if the electrode is first moved about in the buffer solution and then held still.



Stability check: measured mV value is displayed.

Note



The stability check can be aborted with **CAL**. However, the calibration accuracy will be compromised.



Calibration with the first buffer is completed. Remove the electrode and temperature probe from the first buffer solution and rinse off both thoroughly.

- If you would like to carry out a one-point calibration, press **CAL** to end the calibration now. The Transmitter then shows the newly determined asymmetry potential (zero point) in the main display and the old slope in the lower display.
- If you would like to carry out a two-point calibration, immerse the electrode in the second buffer solution. Enter the pH value of the second buffer solution as has been done with the first buffer. Now start the calibration again with **ENTER**. The calibration process runs again as for the first buffer.



At the end of calibration the slope and asymmetry potential (based on 25 °C) of the electrode are displayed. Press **ENTER** to end calibration. The Transmitter remains in the Hold state. You can now reinstall the electrode and temperature probe and end the Hold state with **ENTER**. After 20 sec (for measured value stabilization) the Transmitter returns to measuring mode.

Data entry of premeasured electrodes DAT

(if selected in Conf mode)

You can directly enter the slope and asymmetry potential of an electrode. The values must be known, e.g. determined beforehand in the laboratory.



Activate calibration with **CAL**



Mode code "1100"

000 mV

Enter asymmetry potential,
confirm with **ENTER**

0098 mV/pH

Enter slope,
confirm with **ENTER**

98 mV/pH

At the end of calibration the slope and asymmetry potential (based on 25 °C) of the electrode are displayed. Press **ENTER** to end calibration. The Transmitter remains in the Hold state. You can now reinstall the electrode and the temperature probe and end the Hold state with **ENTER**. After a relax time of 20 sec (for measured value stabilization) the Transmitter returns to measuring mode.

Convert slope [%] to slope [mV/pH] at 25 °C

%	78	80	82	84	86	88	90	92	94	96	98	100	102
mV/pH	46.2	47.4	48.5	49.7	50.9	52.1	53.3	54.5	55.6	56.8	58.0	59.2	60.4

Adjustment of temperature probe (CAL 1015)

Note



Incorrectly set parameters may go unnoticed, yet change the measurement properties.

Temperature probe adjustment is particularly useful when using Pt 100 temperature probes. For NTC temperature probes, an adjustment is not required.

CAL



Activate calibration by pressing the **CAL** key.

Using the ▲, ► keys enter mode code "1015" and then press **ENTER**.



Measure the temperature of the process medium using an external thermometer.



Using the ▲, ► keys enter the determined temperature value in the main display. If you take over the temperature value shown in the lower display, the correction is without effect.

ENTER

Press **ENTER** to confirm the temperature value.



The Transmitter remains in the Hold state. You can end the Hold state with **ENTER**. After a relax time of 20 sec (for measured value stabilization) the Transmitter returns to measuring mode.

Measurement

Measuring mode

In the measuring mode the upper display shows the configured process variable (pH or mV) and the lower display the temperature.

Cal info

With **CAL** and mode code "0000" you can activate the cal info. Cal info shows the current calibration data for approx. 20 sec. The 20 sec can be reduced by pressing **ENTER**. During cal info the Transmitter is not in Hold state.

Error info

With **CONF** and mode code "0000" you can activate the error info. Error info shows the most recent error message for approx. 20 sec. After that the message will be deleted. The 20 sec can be reduced by pressing **ENTER**. During error info the Transmitter is not in Hold state.

Manual temperature specification

The  indicator signals that the temperature will be manually specified. The measuring temperature can be set in the configuration, the calibration temperature in calibration.

Hold state

The Transmitter will enter the Hold state under the following conditions:



For calibration: Mode code 1001
Mode code 1015
Mode code 1100
Mode code 2222

configuration: Mode code 1200
Mode code 5555

The loop current is frozen at *Last* or *Fix* (configuration Pg. 23). If the calibration or configuration mode is exited, the Transmitter remains in the Hold state for safety reasons. This prevents undesirable reactions of the connected peripherals (e.g. limit switches, controllers) due to incorrect settings. The measured value and *Hold* are displayed alternately. Now you can check whether the measured value is plausible and specifically end the Hold state with **ENTER**.

The loop current will remain frozen for another 20 sec (relax time). This ensures that the Transmitter can adjust to the new measured value. After that, the Transmitter returns to measuring mode.

4 Diagnostics, Maintenance and Cleaning

Sensoface[®], Sensocheck[®]

Note



Sensocheck[®] can only be applied with a glass electrode. When a Durafet[®] electrode is used, Sensocheck[®] is not active.

Three Smileys provide information on wear and required maintenance. However, the unit can still determine the measured variable and output it via the loop current.



Sensoface[®] provides information on the electrode state. The slope, asymmetry potential and response time during calibration are evaluated. **Sensocheck[®]** continuously monitors the glass and reference electrode. With Sensocheck[®] turned off no 😊 appears.

Note



The worsening of a Sensoface[®] criterion leads to the devaluation 😞 or 😓 of the Sensoface[®] indicator.





An improvement 😊 of the Sensoface[®] indicator can only take place after calibration or removal of an electrode defect. 😊 is only displayed when Sensocheck[®] has been activated.

Note



The condition for accurate information is proper calibration.

Sensoface [®] displays during calibration		
Display	Problem	Status
	Electrode response time	😊 The electrode adjusts slowly. You should consider replacing it. It may be possible to achieve an improvement by cleaning or, in the case of an electrode stored dry, by "watering". 😞 The electrode adjusts very slowly to the measured value. Correct measurement is no longer ensured. The electrode should be replaced.
	Asymmetry potential and slope	😊 Asymmetry potential (zero point) and slope of the electrode are still okay, however the electrode should be replaced soon. 😞 Asymmetry potential (zero point) and/or slope of the electrode have reached values which no longer ensure proper calibration. It is advisable to replace the electrode.

Sensoface® displays during measurement		
Display	Problem	Status
	Calibration timer	 Over 80 % of the calibration interval has already past.  The calibration interval has been exceeded.
	Electrode defect	 Check the electrode and its connections (also see error messages 33 and 34).

Error Messages

When one of the following error messages is output, the unit can no longer correctly determine the measured variable or output it via the loop current.



During an error message the alarm LED flashes. The alarm response time is permanently set to 10 sec.







During alarm condition the unit does not switch into Hold state. The current loop will remain active and still represents the currently displayed reading. If 22 mA function is configured (see page 23), error messages will also be indicated with a 22 mA signal.

Error info







Pressing **CONF** and entering mode code "0000" is going to activate the error info. Error info shows the most recent error message for approx. 20 sec. After that the message will be deleted. The 20 sec can be reduced by pressing **ENTER**. During error info the unit is not in Hold state.

Error number	Display (flashing)	Problem	Possible causes
Err 01		pH electrode	- Electrode defective - Too little electrolyte in electrode - Electrode not connected - Break in electrode cable - Incorrect electrode connected - Measured pH value less than 0 or greater than +14
Err 02		ORP electrode	- Electrode defective - Electrode not connected - Break in electrode cable - Measured electrode voltage less than -1500 mV or greater than +1500 mV

Error number	Display (flashing)	Problem	Possible causes
Err 03		Temperature probe	<ul style="list-style-type: none"> - Incorrect temperature probe connected or configured - Open or short circuit in temperature probe - Measured temperature less than $-20\text{ }^{\circ}\text{C}$ or greater than $+150\text{ }^{\circ}\text{C}$ (NTC: $+130\text{ }^{\circ}\text{C}$)
Err 21		Loop current	<ul style="list-style-type: none"> - Measured value below configured current beginning - Check configuration current beginning (see Pg. 23)
Err 22		Loop current	<ul style="list-style-type: none"> - Measured value above configured current end - Check configuration current end (see Pg. 23)
Err 23		Loop current	<ul style="list-style-type: none"> - Configured current span too large or too small (Difference between current beginning and end)
Err 33		Glass electrode	<ul style="list-style-type: none"> - Glass electrode defective - Connection cable or electrode cap defective - Connection terminals or electrode cap dirty
Err 34		Reference electrode	<ul style="list-style-type: none"> - Reference electrode defective - Connection cable or electrode cap defective - Connection terminals or electrode cap dirty - Jumper between terminal 4 and 5 missing (see wiring diagrams on Pg. 14 and the following)
Err 98	CONF	System error	<ul style="list-style-type: none"> - Configuration or calibration data defective; completely reconfigure and recalibrate the unit - Measured value transmission defective - Memory error in unit program (PROM defective)
Err 99	FAIL	Factory settings	<ul style="list-style-type: none"> - EEPROM or RAM defective, - Error in factory settings <p>This error message normally should not occur, as the data are protected from loss by multiple safety functions. Should this error message nevertheless occur, there is no remedy. The Transmitter must be repaired and recalibrated at the factory.</p>

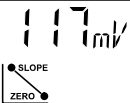
Calibration Error Messages

(only during calibration)

Display	Problem	Possible causes
	Asymmetry potential (zero) out of range (± 60 mV)	<ul style="list-style-type: none"> - Electrode "worn out" - Buffer solutions contaminated - Buffer does not belong to configured buffer set - Temperature probe not immersed in buffer solution (for automatic temperature compensation) - Wrong buffer temperature set (for manual temperature specification) - No zero point adjustment performed for electrode with nominal zero point < pH 6 or > pH 8
	Electrode slope out of range (80 – 103 %)	<ul style="list-style-type: none"> - Electrode "worn out" - Buffer solutions contaminated - Buffer does not belong to configured buffer set - Temperature probe not immersed in buffer solution (for automatic temperature compensation) - Wrong buffer temperature set (for manual temperature specification) - Electrode used has different nominal slope
	Problems during recognition of the buffer solution	<ul style="list-style-type: none"> - Same or similar buffer solution was used for both calibration steps - Buffer solution used does not belong to buffer set currently configured in the unit - During manual calibration the buffer solutions were not used in the specified order - Buffer solutions contaminated - Electrode defective - Electrode not connected - Electrode cable defective - Wrong buffer temperature set (for manual temperature specification)
	Calibration was canceled after approx. 2 minutes, because the electrode drift was too large.	<ul style="list-style-type: none"> - Electrode defective or dirty - No electrolyte in the electrode - Electrode cable insufficiently shielded or defective - Strong electric fields influence the measurement - Major temperature fluctuation of the buffer solution - No buffer solution or extremely diluted

Diagnostics Functions

Cal info

Pressing **CAL** and entering mode code "0000" is going to activate the cal info. Cal info shows the current calibration data for approx. 20 sec. During cal info the Transmitter is not in Hold state.

Error info

Pressing **CONF** and entering mode code "0000" is going to activate the error info. Error info shows the most recent error message for approx. 20 sec. After that the message will be deleted. The 20 sec can be reduced by pressing **ENTER**. During error info the Transmitter is not in Hold state.

Display electrode potential

During electrode maintenance it is useful to directly indicate the electrode potential. This allows, for example, to check electrode response after cleaning.

Pressing **CAL** and entering mode code "2222" will display the electrode potential. The Transmitter is in Hold state.

Display loop current

Pressing **ENTER** in measuring mode displays the loop current for a few seconds.

Current source

To check the connected peripherals (e.g. limit switches, controllers), the loop current can be manually specified.

Warning



In the current source function the loop current no longer follows the measured value! It is manually specified.

Therefore, it must be ensured that the connected devices (control room, controllers, indicators) do not interpret the current value as a measured value!

Pressing **CONF** and entering mode code "5555" is going to activate the current source function. Specify the loop current using **▶**, **▲** and **ENTER**. The present loop current is shown in the lower display. Pressing **CONF** exits the current source function again.

GainCheck® manual unit self-test

To start press **▲** and **▶** simultaneously.

A display test is carried out, the software version is displayed and the memory and measured-value transmission checked.

Automatic unit self-test

The automatic unit self-test checks the memory and the measured-value transmission. It runs automatically in the background at fixed intervals.

Maintenance and Cleaning

Maintenance

The APT2000PH Transmitter contains no user-repairable components. If problems persist even after reviewing section 4, please contact the factory.

Cleaning

To remove dust, dirt and spots, the external surfaces of the unit may be wiped with a damp, lint-free cloth. A mild household cleaner may also be used if necessary.

5 Annex

Product Line

Units

	Ref. No.
pH/ORP Transmitter for application in safe areas or hazardous locations DIV 2 (USA/Canada only)	APT2000PH-0-00
pH/ORP IS Transmitter for application in hazardous locations DIV 1 (USA/Canada) / Zone 1 (Europe)	APT2000PH-0-IS
pH/ORP Transmitter with HART [®] communication for application in safe areas or hazardous locations DIV 2 (USA/Canada only)	APT2000PH-H-00
pH/ORP IS Transmitter with HART [®] communication, for application in hazardous locations DIV 1 (USA/Canada) / Zone 1 (Europe)	APT2000PH-H-IS

Mounting Accessories

	Ref. No.
Pipe-mount kit	51205988-001
Panel-mount kit	51205990-001
Protective hood	51205989-001

Further Accessories

	Ref. No.
HART [®] test socket, integrated in Pg cable gland (for APT2000PH-H-.. Transmitter only)	51205991-001

Specifications

APT2000PH-0(H)-00 Transmitter

pH/mV input

Ranges	pH value	0.00 to +14.00
	mV value	-1500 to +1500 mV
Glass	Input resistance	> $0.5 \cdot 10^{12} \Omega$
	Input current (20 °C)**	< $2 \cdot 10^{-12} \text{ A}$
Reference	Input resistance	> $1 \cdot 10^{10} \Omega$
	Input current (20 °C)**	< $1 \cdot 10^{-10} \text{ A}$
Max. cable length	Glass electrode	20 m
Accuracy (± 1 count)	pH < 0.02	TC: 0.0021 pH/K
	mV < 1 mV	TC: 0.1 mV/K

Electrode monitoring Sensocheck®: Monitoring of glass and reference electrode (can be switched off)

Alarm limits Determination during calibration

Electrode standardization*

- Calimatic® automatic calibration with the buffer sets:
 - 01- Knick technical buffers (correspond to Mettler Toledo techn. buffers) 2.00/4.01/7.00/9.21
 - 02- Merck/Riedel de Haën 2.00/4.00/7.00/9.00/12.00
 - 03- Ciba (94) 2.06/4.00/7.00/10.00
 - 04- Techn. buffers NIST 1.68/4.00/7.00/10.01/12.46
 - 05- Standard buffers NIST 4.006/6.865/9.180
 - 06- HACH 4.00/7.00/10.18

APT2000PH-0(H)-IS Transmitter

pH/mV input EEx ia IIC

Ranges	pH value	0.00 to +14.00
	mV value	-1500 to +1500 mV
Glass	Input resistance	> $0.5 \cdot 10^{12} \Omega$
	Input current (20 °C)**	< $2 \cdot 10^{-12} \text{ A}$
Reference	Input resistance	> $1 \cdot 10^{10} \Omega$
	Input current (20 °C)**	< $1 \cdot 10^{-10} \text{ A}$
Max. cable length	Glass electrode	20 m
Accuracy (± 1 count)	pH < 0.02	TC: 0.0021 pH/K
	mV < 1 mV	TC: 0.1 mV/K

Electrode monitoring Sensocheck®: Monitoring of glass and reference electrode (can be switched off)

Alarm limits Determination during calibration

Electrode standardization*

- Calimatic® automatic calibration with the buffer sets:
 - 01- Knick technical buffers (correspond to Mettler Toledo techn. buffers) 2.00/4.01/7.00/9.21
 - 02- Merck/Riedel de Haën 2.00/4.00/7.00/9.00/12.00
 - 03- Ciba (94) 2.06/4.00/7.00/10.00
 - 04- Techn. buffers NIST 1.68/4.00/7.00/10.01/12.46
 - 05- Standard buffers NIST 4.006/6.865/9.180
 - 06- HACH 4.00/7.00/10.18

APT2000PH-0(H)-00 Transmitter

	<ul style="list-style-type: none"> Manual entry of individual buffer values (MAN) Data entry for pre-measured electrodes (DAT)
Calibration timer	0 to 9999 h
Calibration ranges	Asymmetry potential ± 60 mV Slope 80 to 103 % Display message when range is exceeded (Sensoface®)
Nominal zero	Valid range ± 200 mV Valid pH range pH 6.5 to 7.5 (without automatic temperature correction)
Temp input	Pt 100 / Pt 1000 / NTC 8.55 k Ω
Ranges	NTC -10.0 to +130.0 °C +14 to +266 °F Pt -20.0 to +150.0 °C -4 to +302 °F
Resolution	0.1 °C / 1 °F
Accuracy	< 0.5 K*** ± 1 count
Temp compensation	automatic with Pt 100 / Pt 1000 / NTC 8.55 k Ω or manual
Display	LC display, alarm LED
Loop current	4 to 20 mA, floating 22 mA for error message* supply voltage 12 to 30 V
Current error	< 0.3 % of current value ± 50 μ A
Current source	3.80 mA to 22.00 mA

APT2000PH-0(H)-IS Transmitter

	<ul style="list-style-type: none"> Manual entry of individual buffer values (MAN) Data entry for pre-measured electrodes (DAT)
Calibration timer	0 to 9999 h
Calibration ranges	Asymmetry potential ± 60 mV Slope 80 to 103 % Display message when range is exceeded (Sensoface®)
Nominal zero	Valid range ± 200 mV Valid pH range pH 6.5 to 7.5 (without automatic temperature correction)
Temp input	Pt 100 / Pt 1000 / NTC 8.55 k Ω EEx ia IIC
Ranges	NTC -10.0 to +130.0 °C +14 to +266 °F Pt -20.0 to +150.0 °C -4 to +302 °F
Resolution	0.1 °C / 1 °F
Accuracy	< 0.5 K*** ± 1 count
Temp compensation	automatic with Pt 100 / Pt 1000 / NTC 8.55 k Ω or manual
Display	LC display, alarm LED
Loop current	4 to 20 mA, floating 22 mA for error message* supply voltage 12 to 30 V I _{max} = 100 mA, P _{max} = 0.8 W
Current error	< 0.3 % of current value ± 50 μ A
Current source	3.80 mA to 22.00 mA

APT2000PH-0(H)-00 Transmitter

Start/end of scale* configurable within pH or mV ranges

Spans*
 pH value 2.00 to 14.00
 mV value 200 to 3000 mV

HART® communication
 (HART transmitter only) digital communication via FSK modulation of loop current, point-to-point connection, reading of device identification, measured values, status and messages reading and writing of parameters

Power supply output for Durafet cap adapter
 +3 V / 0.5 mA
 -3 V / 0.4 mA

Explosion protection USA/Canada:
 Class I, Div 2, Group A, B, C, D, T4

Data retention > 10 years (EEPROM)

RFI suppression to EN 50081-1 and EN 50081-2

Immunity to interference to EN 50082-1 and EN 50082-2

Temperature Operating/ambient temp
 -20 to +55 °C
 Transport and storage temp
 -20 to +70 °C

APT2000PH-0(H)-IS Transmitter

Start/end of scale* configurable within pH or mV ranges

Spans*
 pH value 2.00 to 14.00
 mV value 200 to 3000 mV

HART® communication
 (HART transmitter only) digital communication via FSK modulation of loop current, point-to-point connection, reading of device identification, measured values, status and messages reading and writing of parameters

Power supply output for Durafet cap adapter
 +3 V / 0.5 mA
 -3 V / 0.4 mA

Explosion protection USA/Canada:
 IS, Class I, Div 1, Group A, B, C, D, T4
 Europe:
 II 2(1)G EEx ib [ia] IIC T6
 CE 0032 TÜV 99 ATEX 1448

Data retention > 10 years (EEPROM)

RFI suppression to EN 50081-1 and EN 50081-2

Immunity to interference to EN 50082-1 and EN 50082-2

Temperature Operating/ambient temp
 -20 to +55 °C
 Transport and storage temp
 -20 to +70 °C

APT2000PH-0(H)-00 Transmitter

Enclosure Material: thermoplastic polyester, re-inforced (polybutylene terephthalate)
Protection: IP 65, NEMA 4X
Color: bluish gray RAL 7031

Cable glands 3 breakthroughs for Pg 13.5
2 breakthroughs for NPT 1/2 " or Rigid Metallic Conduit

Dimensions See Dimension drawings, Pg. 7 ff

Weight approx. 1 kg

* user defined ** doubles every 10 K

*** Pt 100: 1K

APT2000PH-0(H)-IS Transmitter

Enclosure Material: thermoplastic polyester, re-inforced (polybutylene terephthalate)
Protection: IP 65, NEMA 4X
Color: bluish gray RAL 7031

Cable glands 3 breakthroughs for Pg 13.5
2 breakthroughs for NPT 1/2 " or Rigid Metallic Conduit

Dimensions See Dimension drawings, Pg. 7 ff

Weight approx. 1 kg

* user defined ** doubles every 10 K

*** Pt 100: 1K

Type Examination Certificate



Translation

EC-TYPE EXAMINATION CERTIFICATE

- (1)
- (2) Equipment or Protective System intended for use in potentially explosive atmospheres - **Directive 94/9/EC**
- (3) EC-Type Examination Certificate Number

**TÜV 99 ATEX 1448**

- (4) Equipment or Protective System: **Analytical process transmitter type APT2000 PH*-IS**
- (5) Manufacturer: **Honeywell Inc.**
- (6) Address: **USA - Fort Washington PA 19034, 1100 Virginia Drive**
- (7) This equipment or protective system and any acceptable variation thereto is specified in the schedule to this certificate and the documents therein referred to.
- (8) The TÜV Hannover/Sachsen-Anhalt e.V., TÜV Certification Body N° 0032 in accordance with Article 9 of the Council Directive 94/9/EC of March 23, 1994, certifies that this equipment or protective system has been found to comply with the Essential Health and Safety Requirements relating to the design and construction of equipment and protective systems intended for use in potentially explosive atmospheres given in Annex II to the Directive.
- The examination and test results are recorded in confidential report N° 99/PX12992.
- (9) Compliance with the Essential Health and Safety Requirements has been assured by compliance with:
- EN 50 014:1997 EN 50 020:1994**
- (10) If the sign "X" is placed after the certification number, it indicates that the equipment or protective system is subject to special conditions for safe use specified in the schedule to this certificate.
- (11) This EC-TYPE EXAMINATION CERTIFICATE relates only to the design and construction of the specified equipment or protective system. If applicable, further requirements of this Directive apply to the manufacture and supply of this equipment or protective system.
- (12) The marking of the equipment or protective system shall include the following:

**II 2 (1) G EEx Ib [Ia] IIC T6**

Hannover, 1999-06-23

TÜV Hannover/Sachsen-Anhalt e.V.
 TÜV CERT-Zertifizierungsstelle
 Am TÜV 1
 D-30619 Hannover

U. Heide
 Head of the
 Certification Body





(13)

SCHEDULE

(14) **EC-TYPE EXAMINATION CERTIFICATE N° TÜV 99 ATEX 1448**

(15) Description of equipment or protective system

The analytical process transmitter type APT2000 PH⁺-IS is used for the recognition and processing of electrochemical quantities.

The maximum permissible ambient temperature is 55°C.

Electrical data

Current loop.....in type of protection "Intrinsic Safety" EEx ia IIC
(terminals 14, 15) only for the connection to a certified intrinsically safe circuit with the following maximum values:

$U_i = 30 \text{ V}$
 $I_i = 100 \text{ mA}$
 $P_i = 0.8 \text{ W}$
 effective internal capacitance $C_i = 20 \text{ nF}$
 effective internal inductance $L_i = 0.2 \text{ mH}$

pH-measuring loop.....in type of protection "Intrinsic Safety" EEx ia IIC
(terminals 1/2, 4, 5)

Maximum values:
 $U_o = 10 \text{ V}$
 $I_o = 12 \text{ mA}$
 $P_o = 15 \text{ mW}$
 $R_i = 450 \Omega$
 Characteristic: linear
 effective internal capacitance $C_i = 50 \text{ nF}$
 The effective internal inductance is negligibly small.

max. permissible external capacitance $C_o = 3 \mu\text{F}$
 max. permissible external inductance $L_o = 200 \text{ mH}$

Temperature measuring loop...in type of protection "Intrinsic Safety" EEx ia IIC
(terminals 7, 8)

Maximum values:
 $U_o = 5 \text{ V}$
 $I_o = 3 \text{ mA}$
 $P_o = 4 \text{ mW}$
 $R_i = 1900 \Omega$
 Characteristic: linear
 effective internal capacitance $C_i = 250 \text{ nF}$
 The effective internal inductance is negligibly small.

max. permissible external capacitance $C_o = 100 \mu\text{F}$
 max. permissible external inductance $L_o = 1 \text{ H}$

KAP 1118 80020



Schedule EC-type examination certificate N° TÜV 99 ATEX 1448

DF-output.....in type of protection "Intrinsic Safety" EEx Ia IIC
(terminals 17, 18, 19)

Maximum values:

 $U_{0e} = 10 \text{ V}$ $I_{0e} = 14 \text{ mA}$ $P_{0e} = 35 \text{ mW}$ $R_i = 712 \ \Omega$

Characteristic: linear

effective internal capacitance $C_i = 25 \text{ nF}$

The effective internal inductance is negligibly small.

max. permissible external capacitance $C_o = 3 \ \mu\text{F}$ max. permissible external inductance $L_o = 150 \text{ nH}$

EP
(Terminal 16)

for the connection to the equipotential bonding system

The current loop is safely separated from the measuring loops and the DF-output up to a voltage of 60 V. The pH-measuring loop, the temperature measuring loop and the DF-output are galvanically connected.

(16) Test documents are listed in the test report No. 99/PX12992.

(17) Special condition for safe use
none.

(18) Essential Health and Safety Requirements
no additional ones

Control / Installation drawing

Measurement Loop Hazardous Area Location

IS Class I, Division 1, Groups A, B, C, D
 IS Class II, Division 1, Groups E, F, G
 IS Class III, Division 1
 IS Class I, Zone D, Group IIC

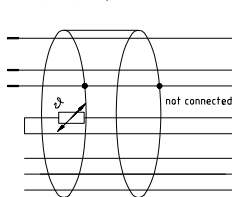

Hazardous Location Class I, Div 1

2-Wire Transmitter (intrinsically safe apparatus)
 APT2000pH-0-IS, APT2000pH-H-IS
 IS, Class I, Division 1, Groups A, B, C, D, T4 @ 55°C; Type 2
 Class I, Zone 1, IIC, T4 @ 55°C; Type 2

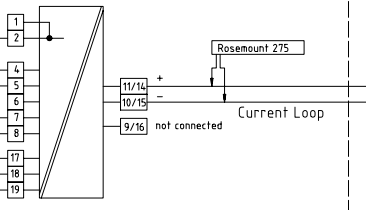

pH-Measuring Loop

Entity Parameters: Terminals 1, 2, 4, 5, and 6
 $V_i, U_0 = 10\text{ V}$; $I_i, I_0 = 10\text{ mA}$; $P_{max}, P_0 = 25\text{ mW}$
 Class I, Division 1, Groups A & B Class I, Zone 1, IIC
 $C_a, C_0 = 3\text{ }\mu\text{F}$; $L_a, L_0 = 330\text{ mH}$
 Class I & II, Division 1, Groups C & E Class I, Zone 1, IIB
 $C_a, C_0 = 9\text{ }\mu\text{F}$; $L_a, L_0 = 1\text{ H}$
 Class I, II, III Division 1, Groups D, F & G Class I, Zone 1, IIA
 $C_a, C_0 = 24\text{ }\mu\text{F}$; $L_a, L_0 = 1\text{ H}$

Entity Parameters: Terminals 10/15 and 11/14

$V_{max}, U_i = 30\text{ V}$ $C_i = 32.4\text{ nF}$
 $I_{max}, I_i = 100\text{ mA}$ $L_i = 240\text{ }\mu\text{H}$
 $P_{max}, P_i = 0.8\text{ W}$

Temp-Measuring Loop

Entity Parameters: Terminals 7 and 8
 $V_{oc}, U_0 = 5\text{ V}$; $I_{sc}, I_0 = 3\text{ mA}$; $P_{max}, P_0 = 4\text{ mW}$
 Class I, Division 1, Groups A & B Class I, Zone 1, IIC
 $C_a, C_0 = 2000\text{ }\mu\text{F}$; $L_a, L_0 = 1\text{ H}$
 Class I & II, Division 1, Groups C & E Class I, Zone 1, IIB
 $C_a, C_0 = 6000\text{ }\mu\text{F}$; $L_a, L_0 = 1\text{ H}$
 Class I, II, III Division 1, Groups D, F & G Class I, Zone 1, IIA
 $C_a, C_0 = 16000\text{ }\mu\text{F}$; $L_a, L_0 = 1\text{ H}$

Entity Parameters: Terminals 1, 2, 4, 5, 6, 7, 8, 17, 18 and 19

$V_i, U_0 = 10\text{ V}$; $I_i, I_0 = 27\text{ mA}$; $P_i, P_0 = 66\text{ mW}$
 Class I, Division 1, Groups A & B Class I, Zone 1, IIC
 $C_a, C_0 = 3\text{ }\mu\text{F}$; $L_a, L_0 = 50\text{ mH}$
 Class I & II, Division 1, Group C Class I, Zone 1, IIB
 $C_a, C_0 = 9\text{ }\mu\text{F}$; $L_a, L_0 = 180\text{ mH}$
 Class I, II, III Division 1, Group D Class I, Zone 1, IIA
 $C_a, C_0 = 24\text{ }\mu\text{F}$; $L_a, L_0 = 400\text{ mH}$

DF-Supply

Entity Parameters: Terminals 17, 18 and 19
 $V_{oc}, U_0 = 10\text{ V}$; $I_{sc}, I_0 = 14\text{ mA}$; $P_{max}, P_0 = 35\text{ mW}$
 Class I, Division 1, Groups A & B Class I, Zone 1, IIC
 $C_a, C_0 = 3\text{ }\mu\text{F}$; $L_a, L_0 = 170\text{ mH}$
 Class I & II, Division 1, Groups C & E Class I, Zone 1, IIB
 $C_a, C_0 = 9\text{ }\mu\text{F}$; $L_a, L_0 = 620\text{ mH}$
 Class I, II, III Division 1, Groups D, F & G Class I, Zone 1, IIA
 $C_a, C_0 = 24\text{ }\mu\text{F}$; $L_a, L_0 = 1\text{ H}$

Non-Hazardous Location

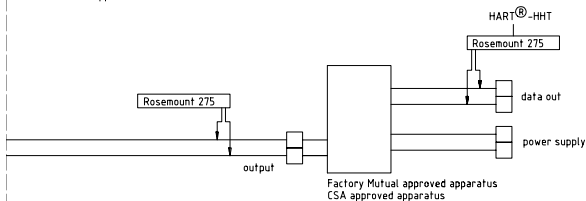
Transmitter Power Supply
(associated apparatus)

NOTES :

- $V_{max}, U_i = V_{oc}, V_t, \text{ or } U_0$
 $C_i + C_{cable} < C_a \text{ or } C_0$
 - $I_{max}, I_i > I_{sc}, I_t, \text{ or } I_0$
 $L_i + L_{cable} < L_a \text{ or } L_0$
 - $P_{max} > P_0$
- Installation must be in accordance with the National Electrical Code (ANSI/NFPA 70) and ANSI/ISA RP12.6 in US, Canadian Electric Code (Can3-M421) in Canada.
 - Associated apparatus must be FMRC and CSA Approved and must be used in an FMRC and CSA Approved configuration. Use of the Rosemount Model 275 Communicator in Zones is not an FMRC Approved configuration. The control drawing for the associated apparatus must be followed when installing this equipment.
 - Control equipment connected to the associated apparatus must not use or generate more than 250 V.
 - The intrinsically safe equipment connecting to 1, 2, 4, 5, 6 and 7, 8 must be FMRC and CSA Approved or be simple apparatus (a device which will neither generate nor store more than 12 V, 0.1 A, 25 mW or 20 mJ). The intrinsically safe equipment connecting to 17, 18 and 19 must be FMRC and CSA Approved.
 - No revisions to drawing without prior FMRC and CSA Approval.
 - Use of the Rosemount Model 275 Communicator is FM Approved for Division use only, see note 3. When using the Rosemount Model 275 Communicator in the loop between the associated apparatus and the APT2000pH-H-IS 2-Wire Transmitter, the maximum loop inductance must be less than the marked L_a of the associated apparatus to account for the I_{sc} from the Model 275 Communicator. Refer to the Rosemount Installation Drawing 00275-0081 to determine the allowable loop inductance.
 - The Rosemount Model 275 Communicator is not approved by CSA for use in the entity concept. For CSA application the Rosemount Model 275 Communicator must only be used on the non-hazardous side of the barrier/transmitter power supply.

Version **Honeywell**

Buffer Charts

-01- Krick technical buffers
(correspond to Mettler-Toledo technical buffers)

°C	pH			
0	2.03	4.01	7.12	9.52
5	2.02	4.01	7.09	9.45
10	2.01	4.00	7.06	9.38
15	2.00	4.00	7.04	9.32
20	2.00	4.00	7.02	9.26
25	2.00	4.01	7.00	9.21
30	1.99	4.01	6.99	9.16
35	1.99	4.02	6.98	9.11
40	1.98	4.03	6.97	9.06
45	1.98	4.04	6.97	9.03
50	1.98	4.06	6.97	8.99
55	1.98	4.08	6.98	8.96
60	1.98	4.10	6.98	8.93
65	1.99	4.13	6.99	8.90
70	1.99	4.16	7.00	8.88
75	2.00	4.19	7.02	8.85
80	2.00	4.22	7.04	8.83
85	2.00	4.26	7.06	8.81
90	2.00	4.30	7.09	8.79
95	2.00	4.35	7.12	8.77

-03- Ciba (94) buffers
Nominal values: 2.06, 4.00, 7.00, 10.00

°C	pH			
0	2.04	4.00	7.10	10.30
5	2.09	4.02	7.08	10.21
10	2.07	4.00	7.05	10.14
15	2.08	4.00	7.02	10.06
20	2.09	4.01	6.98	9.99
25	2.08	4.02	6.98	9.95
30	2.06	4.00	6.96	9.89
35	2.06	4.01	6.95	9.85
40	2.07	4.02	6.94	9.81
45	2.06	4.03	6.93	9.77
50	2.06	4.04	6.93	9.73
55	2.05	4.05	6.91	9.68
60	2.08	4.10	6.93	9.66
65	2.07*	4.10*	6.92*	9.61*
70	2.07	4.11	6.92	9.57
75	2.04*	4.13*	6.92*	9.54*
80	2.02	4.15	6.93	9.52
85	2.03*	4.17*	6.95*	9.47*
90	2.04	4.20	6.97	9.43
95	2.05*	4.22*	6.99*	9.38*

* extrapolated

-02- Merck-Titrisole, Riedel Fixanale

°C	pH				
0	2.01	4.05	7.13	9.24	12.58
5	2.01	4.04	7.07	9.16	12.41
10	2.01	4.02	7.05	9.11	12.26
15	2.00	4.01	7.02	9.05	12.10
20	2.00	4.00	7.00	9.00	12.00
25	2.00	4.01	6.98	8.95	11.88
30	2.00	4.01	6.98	8.91	11.72
35	2.00	4.01	6.96	8.88	11.67
40	2.00	4.01	6.95	8.85	11.54
45	2.00	4.01	6.95	8.82	11.44
50	2.00	4.00	6.95	8.79	11.33
55	2.00	4.00	6.95	8.76	11.19
60	2.00	4.00	6.96	8.73	11.04
65	2.00	4.00	6.96	8.72	10.97
70	2.01	4.00	6.96	8.70	10.90
75	2.01	4.00	6.96	8.68	10.80
80	2.01	4.00	6.97	8.66	10.70
85	2.01	4.00	6.98	8.65	10.59
90	2.01	4.00	7.00	8.64	10.48
95	2.01	4.00	7.02	8.64	10.37

-04- NIST technical buffers

°C	pH				
0	1.67	4.00	7.11 ₅	10.32	13.42
5	1.67	4.00	7.08 ₅	10.25	13.21
10	1.67	4.00	7.06	10.18	13.01
15	1.67	4.00	7.04	10.12	12.80
20	1.67 ₅	4.00	7.01 ₅	10.06	12.64
25	1.68	4.00₅	7.00	10.01	12.46
30	1.68	4.01 ₅	6.98 ₅	9.97	12.30
35	1.69	4.02 ₅	6.98	9.93	12.13
40	1.69	4.03	6.97 ₅	9.89	11.99
45	1.70	4.04 ₅	6.97 ₅	9.86	11.84
50	1.70 ₅	4.06	6.97	9.83	11.71
55	1.71 ₅	4.07 ₅	6.97	9.83 [†]	11.57
60	1.72	4.08 ₅	6.97	9.83 [†]	11.45
65	1.73	4.10	6.98	9.83 [†]	11.45 [†]
70	1.74	4.13	6.99	9.83 [†]	11.45 [†]
75	1.75	4.14	7.01	9.83 [†]	11.45 [†]
80	1.76 ₅	4.16	7.03	9.83 [†]	11.45 [†]
85	1.78	4.18	7.05	9.83 [†]	11.45 [†]
90	1.79	4.21	7.08	9.83 [†]	11.45 [†]
95	1.80 ₅	4.23	7.11	9.83 [†]	11.45 [†]

† values complemented

-05- NIST standard-buffers

°C	pH		
0	4.010	6.984	9.464
5	4.004	6.951	9.395
10	4.000	6.923	9.332
15	3.999	6.900	9.276
20	4.001	6.881	9.225
25	4.006	6.865	9.180
30	4.012	6.853	9.139
35	4.021	6.844	9.102
40	4.031	6.838	9.068
45	4.043	6.834	9.038
50	4.057	6.833	9.011
55	4.071	6.834	8.985
60	4.087	6.836	8.962
65	4.109	6.841	8.942
70	4.126	6.845	8.921
75	4.145	6.852	8.903
80	4.164	6.859	8.885
85	4.185	6.868	8.868
90	4.205	6.877	8.850
95	4.227	6.886	8.833

-06- HACH buffers

Nominal values: 4.00, 7.00, 10.18

°C	pH		
0	4.00	7.14	10.30
5	4.00	7.10	10.23
10	4.00	7.04	10.11
15	4.00	7.04	10.11
20	4.00	7.02	10.05
25	4.01	7.00	10.00
30	4.01	6.99	9.96
35	4.02	6.98	9.92
40	4.03	6.98	9.88
45	4.05	6.98	9.85
50	4.06	6.98	9.82
55	4.07	6.98	9.79
60	4.09	6.99	9.76
65	4.09 ⁾	6.99 ⁾	9.76 ⁾
70	4.09 ⁾	6.99 ⁾	9.76 ⁾
75	4.09 ⁾	6.99 ⁾	9.76 ⁾
80	4.09 ⁾	6.99 ⁾	9.76 ⁾
85	4.09 ⁾	6.99 ⁾	9.76 ⁾
90	4.09 ⁾	6.99 ⁾	9.76 ⁾
95	4.09 ⁾	6.99 ⁾	9.76 ⁾

* values complemented

Buffer values up to 60 °C as specified by Bergmann & Beving Process AB.

Glossary

Asymmetry potential (zero point)	The voltage which a pH electrode gives off at a pH of 7. The asymmetry potential is different for every electrode and changes with age and wear.	Cap adapter	Adapter integrated in the protective cap of the Durafet® electrode. Here, the signal of the pH-sensitive FET is converted to a voltage corresponding to the signal of a glass electrode. This voltage is led to the pH input of the Transmitter and is processed further as usual. The adapter is directly supplied from the Transmitter.
Buffer set	Contains selected buffer solutions which can be used for automatic calibration with the Calimatic® feature. The buffer set must be selected prior to calibration.	Combination electrode	Combination of glass and reference electrode in one body.
Buffer solution	Solution with an exactly defined pH value for calibrating a pH meter.	Durafet®	Durafet® combination pH/ORP electrodes consist of an ISFET measuring electrode, a reference electrode and a temperature sensor. A cap adapter provides a pH signal similar to a glass electrode to allow connection to any conventional pH meter.
Calibration	Adjustment of the pH meter to the current electrode characteristics. The asymmetry potential (zero point) and slope are adjusted. Either a one- or two-point calibration can be carried out. With one-point calibration only the asymmetry potential is adjusted.	Electrode slope	Is indicated in % of the theoretical slope (59.2 mV/pH at 25 °C). The electrode slope is different for every electrode and changes with age and wear.
Calibration buffer set	See Buffer set.	Electrode zero point	See Asymmetry potential.
Calimatic®	Automatic buffer recognition. Before the first calibration, the buffer set used must be activated once. The patented Calimatic® then automatically recognizes the buffer solution used during calibration.		

Equipotential bonding	Connection to ground to protect against electrostatic discharge within intrinsically safe installations (necessary only for meeting CENELEC/ATEX requirements – not required by FM/CSA).	One-point calibration	Calibration with which only the electrode asymmetry potential (zero point) is taken into consideration. The previous slope value is retained. Only one buffer solution is required for a one-point calibration.
GainCheck[®]	Unit self-test which runs automatically in the background at fixed intervals. The memory and measured-value transmission are checked. You can also start the GainCheck [®] manually (see Pg. 20). Then a display test is also conducted and the software version displayed.	pH electrode system	A pH electrode system consist of a glass and a reference electrode. If they are combined in one body, they are referred to as a combination electrode.
HART[®]	H ighway A ddressable R emote T ransducer, digital communication via FSK modulation of the loop current	Response time	Time from the start of a calibration step to the stabilization of the electrode potential.
Meredian[®]	Meredian [®] combination pH/ORP electrodes consist of a glass or metallic measuring electrode, a reference electrode and a temperature probe. They include a permanent reference junction and gel fill for maintenance-free operation.	Sensocheck[®]	Sensocheck [®] continuously monitors the glass and reference electrodes. The resulting information is indicated by the Sensoface [®] indicators. Sensocheck [®] can be switched off.
Mode code	Preset four-digit number to select certain modes.	Sensoface[®]	Sensoface [®] provides information on the status of the electrode. The zero point, slope and response time are evaluated. In addition, the Sensocheck [®] information is indicated.

Slope	See Electrode slope.	Zero point	See Asymmetry potential.
Two-point calibration	Calibration with which the electrode asymmetry potential (zero point) and slope are determined. Two buffer solutions are required for two-point calibration.	Zero point adjustment	Basic adjustment of the Durafet [®] electrode to ensure reliable Senso-face [®] information.

Index

😊😐😞, 32

22 mA signal for alarm, 21, 33
configuring, 23

A

Alarm, 21
response time, 33

Alarm LED, 33

Alarm via loop current, 21, 33
configuring, 23

Assembly, 6

Asymmetry potential
definition, 50
display, 36

Automatic calibration, 26

B

Buffer charts, 48

Buffer set
definition, 50
selecting, 23

Buffer solution, definition, 50

C

Cal info, 31, 36

Calibration, 24
automatic, 26
Calimatic, 26
data entry, 29
definition, 50
manual, 28
temp probe adjustment, 30

Calibration buffer set, definition,
50

Calibration data, display, 36

Calibration error messages, 35

Calibration mode, configuring, 23

Calibration timer interval, configur-
ing, 23

Calimatic, definition, 50

Cap adapter, definition, 50

Cleaning, 37

Combination electrode, definition,
50

Configuration, 22

Connecting
handheld terminal, 9
lines, 9

Connecting cable, fixing, 9

Control / Installation drawing, 46

Current source, 36

D

Diagnostics functions, 36

Dimension drawings, 7

Display, 19

Durafet electrode
definition, 50
wiring, 14
zero point adjustment, 24

E

Electrode monitoring, Sensoface,
20, 32

Electrode potential, display, 36

Electrode slope
definition, 50
display, 36

Electrode type, configuring, 23

Electrode zero point, definition, 50

Equipotential bonding, definition,
51

Error info, 31, 33, 36

Error message, last, 31, 33, 36

Error message via loop current,
21, 33
configuring, 23

Error messages, 33–36

- G**
- GainCheck, 20, 36
 - definition, 51
 - Glossary, 50
- H**
- HART, definition, 51
 - HART communication, 21
 - Hold mode, 31
- I**
- Input voltage, display, 36
 - Installation, 13
- K**
- Keypad, 19
- L**
- Loop current, 21
 - configuring, 23
 - display, instantaneous, 36
 - frozen, 31
 - Hold state, 23
- M**
- Maintenance, 37
 - Manual calibration, 28
 - Manual temperature specification, 31
 - Measuring mode, 31
- Meredian electrode**
- definition, 51
 - wiring, 15
- Messages, Sensoface, 32**
- Mode code, 4**
- definition, 51
- Mounting diagram, 7**
- mV measurement, 31**
- N**
- Nominal zero adjustment, 24
- O**
- One–point calibration, 27, 28
 - definition, 51
 - ORP measurement, 17
 - Outputs, 21
- P**
- Packing list, 6
 - pH electrode system, definition, 51
 - pH measurement, 31
 - Pipe–mount kit, 8
 - Process variable, configuring, 23
 - Product line, 38
 - Protective hood, 8
- R**
- Response time, definition, 51
- S**
- Safety precautions, 3
 - Self–test, manual, 20
 - Sensocheck, 32
 - definition, 51
 - on or off, 23
 - Sensoface, 20
 - definition, 51
 - diagnostics, 32
 - messages, 32
 - Slope
 - definition, 52
 - display, 36
 - Smiley, 32
 - Software version, display, 20, 36
 - Specifications, 39
 - Stripping lengths, 9
- T**
- Temp probe adjustment, 30
 - Temperature detection, configuring, 23
 - Terminals, pulling out, 9
 - Two–point calibration, 28
 - definition, 52
 - Type Examination Certificate, 43

U

Unit self-test
 automatic, 20, 36
 manual, 36

User Interface, 18

W

Wiring
 ORP measurement, 17
 pH measurement, 14

Z

Zero point, definition, 52

Zero point adjustment, 24
 definition, 52

Sensing and Control
Honeywell Inc.
11 West Spring Street
Freeport, IL 61032
USA

Honeywell

Honeywell S. A.
Espace Industriel Nord
Rue André Durouchez
80084 Amiens Cedex 2
France