

## APT2000 Series 2-Wire pH Transmitters

## Specification

### Overview

The Honeywell Analytical Process Transmitter (APT) 2000 Series transmitter is a two-wire 24-Volt device that continuously measures pH or ORP in industrial processes including chemical, pharmaceutical, petrochemical, pulp and paper, and wastewater.

The APT2000's NEMA 4x and IP65 rated enclosure is specifically designed to meet the measurement needs of intrinsically safe, non-incendive and general-purpose areas. Honeywell pH or ORP sensors or a wide variety of competitor electrodes can be used as input to the transmitter. A 4-20 mA output is standard on the APT2000. For bi-directional remote monitoring/control of the process, the Hart communications protocol is available as an option.

### Description

The Honeywell APT2000 series of transmitters offer the widest available selection of advanced features in a reliable and economical instrument.

#### Reliability First

The advanced features of the APT2000 transmitter guarantee complete reliability. The APT2000 continuously monitors sensor and transmitter electronics and immediately displays diagnostic information at the onset of a problem. If an error or diagnostic is found, the transmitter will indicate the appropriate error code or pictograph (see Figure 2), blink a red LED and adjust the error current to 22 mA if desired. A manual loop-back check is available to test the integrity of the 4-20mA output.

#### Quick Problem Assessment

The APT2000 has a large front display for quick recognition of process parameters and diagnostics even at a distance. Only the APT2000 employs *visual feedback* to quicken setup and maintenance times and to minimize errors made during calibrations. Visual feedback refers to pictograph type characters that appear on the display both to prompt and respond to operator and process changes. Pictograph type characters also appear during problem conditions to report diagnostics for easy troubleshooting. There is even a Sensoface<sup>®</sup> pictograph that provides constant feedback to the operator on

whether or not there is a problem with the sensor. These easily learned and recognized symbols make the APT2000 an easy-to-use instrument in any language.

#### Foolproof Calibrations

Calibration is easy with automatic buffer recognition, utilizing a variety of buffer standards recognized worldwide. Foolproof calibrations are ensured with special on-board diagnostics that monitor the step-by-step progress of each calibration. Simple messages with pictographs provide feedback on the status of the calibration. Manual one or two-point calibrations can also be performed for complete flexibility.

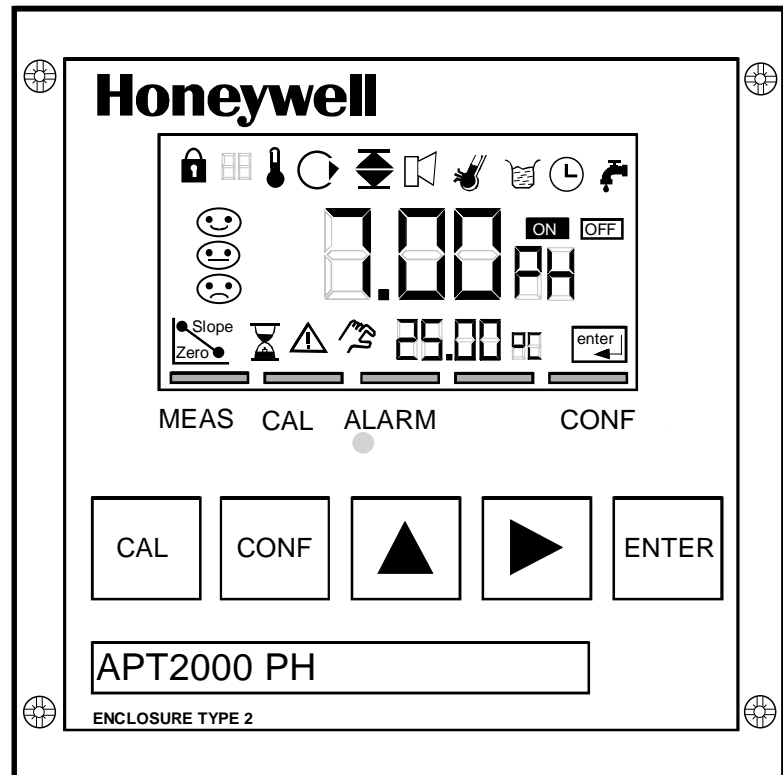

Figure 1 APT2000 Transmitter

**Works with a Variety of Electrodes**

Input to the APT2000 Series includes the Honeywell Durafet II non-glass pH electrode (with the Honeywell cap adapter cable or adapter module), Meredian II glass pH electrodes, or metallic ORP electrodes. In addition, a wide variety of other manufacturers' pH and ORP electrodes can be used with the APT2000.

**Fully Certified**

Area certifications for the APT2000 include both intrinsically safe and non-incendive ratings from FM and CENELEC. Each transmitter comes standard with CE.

**Easily Integrated**

The APT2000 Series transmitters can be continuously remote controlled via HART communications from a handheld terminal or the control room. This option enables additional visibility and control of your process.

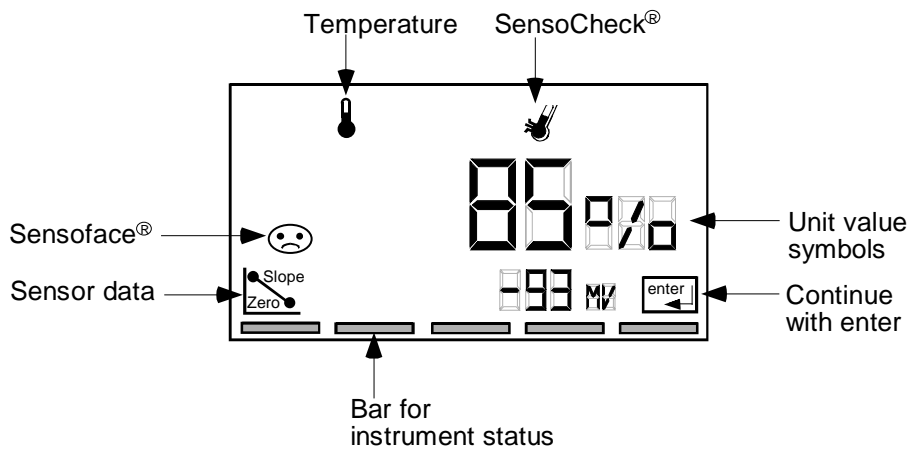

**Figure 2 Example of Electrode Error -- Input Problem**

**Features**

- pH measurement with Durafet II or glass pH electrodes
- Large display with easy-to-read 0.75 inch measured value
- Simple operator interface with basic pictographs
- Application in hazardous and safe areas
- HART bi-directional communications protocol
- Continuous diagnostics for monitoring calibration, probe health, and transmitter self-test
- Manual loopback check for integrity of 4-20 mA output
- Robust, tightly sealed plastic enclosure
- Wall, pipe or panel mounting
- Easy installation with pre-assembled empty enclosure and plug-in terminals
- Optical alarm signaling by blinking red LED
- Integrated current source for simple checking of peripheral devices

**Applications**

The APT2000 pH transmitter is designed to meet the measurement needs of a number of industries, including:

- Chemical
- Pharmaceutical
- Petrochemical
- Pulp and Paper
- Wastewater
- Power

## Specifications

pH/mV Input	
Ranges	pH value: 0.00 to +14.00 pH ORP value: -1500 to +1500 mV
Electrode input types (Internal Pre-amplifier)	Honeywell Durafet II Electrodes with Cap Adapter Honeywell Meredian I/II Glass pH and Metallic ORP Electrodes Other Manufacturer's Electrodes (Consult factory for applicability)
Maximum cable length	Glass electrode: 6.1 m (20 feet) (Honeywell electrodes) Durafet II electrode: 305 m (1000 feet) with junction box ORP electrode: 15.25 m (50 feet) (Honeywell electrodes) with junction box
Accuracy	pH: <0.02 Tc: 0.0021 pH/K mV: <1 mV Tc: 0.1 mV/K
Electrode Diagnostics	
Sensocheck	Continuous monitoring of glass and reference electrodes (not available with Durafet II)
Sensoface	- Provides information on the electrode state via Sensocheck - Monitors asymmetry potential, slope, and response time during calibration
Electrode Calibration	
Operating Modes	- Automatic calibration with the buffer sets: -00- Knick 2.00 / 4.01 / 7.00 / 9.21 -01- Mettler Toledo 2.00 / 4.01 / 7.00 / 9.21 -02- Merck/Riedel de Haen 2.00 / 4.00 / 7.00 / 9.00 / 12.00 -03- Ciba (94) 2.06 / 4.00 / 7.00 / 10.00 -04- Tech. Buffers NIST 1.68 / 4.00 / 7.00 / 10.01 / 12.46 -05- Standard buffers NIST 4.006 / 6.865 / 9.180 -06- Hach buffers 4.00 / 7.00 / 10.18 - Manual input of individual buffer values
Calibration Timer	0 to 9999 hours
Calibration ranges	Asymmetry potential: $\pm 60$ mV Slope: 80 to 103 %
Nominal Zero	Valid range: $\pm 200$ mV Valid pH-range: 6.5...7.5 pH (without automatic temperature correction)
Temperature Input	
Range	Pt100/1000 $\Omega$ RTD: -20.0 to +150.0 $^{\circ}$ C / -4 to +302 $^{\circ}$ F 8550 $\Omega$ Thermistor: -10.0 to +110.0 $^{\circ}$ C / +14 to +230 $^{\circ}$ F
Resolution	0.1 $^{\circ}$ C or 1 $^{\circ}$ F
Accuracy	$\pm 0.5$ $^{\circ}$ C
Temperature Compensation	Automatic Nernstian Compensation using Pt100 $\Omega$ , Pt1000 $\Omega$ , 8550 $\Omega$ or manual
Display	LCD display 76 mm x 48 mm dimensions (3" x 1 7/8"), 7-segment pH/mV Value: character height 17 mm (.66") , meas. symbol 10 mm (.4") Temperature: character height 10 mm (.4") , meas. symbol 7 mm (.33") Sensoface with three states, 5 status bars, 16 pictographs / symbols, Red Alarm LED Security protection with four-digit mode codes to access calibration and configuration options

Supply/Output	
Output current	4 to 20 mA (22 mA for error notification) current loop, floating (3.8 to 20.5 mA)
Supply voltage	12 to 42 V; $I_{max} = 100 \text{ mA}$ ; $P_{max} = 0.8 \text{ W}$
Overrange	22 mA for error messages
Current error	<0.3 % of current value +0.05 mA
Beginning/end of scale	Configurable within measurement range for pH or mV
Minimum span	pH value: 2.00 to 14.00 pH mV value: 200 to 3,000 mV
Durafet II Cap Adapter Power Supply Output	+3V / 0.5 mA -3.5V / 0.4 mA
Current source	3.80 to 22.0 mA

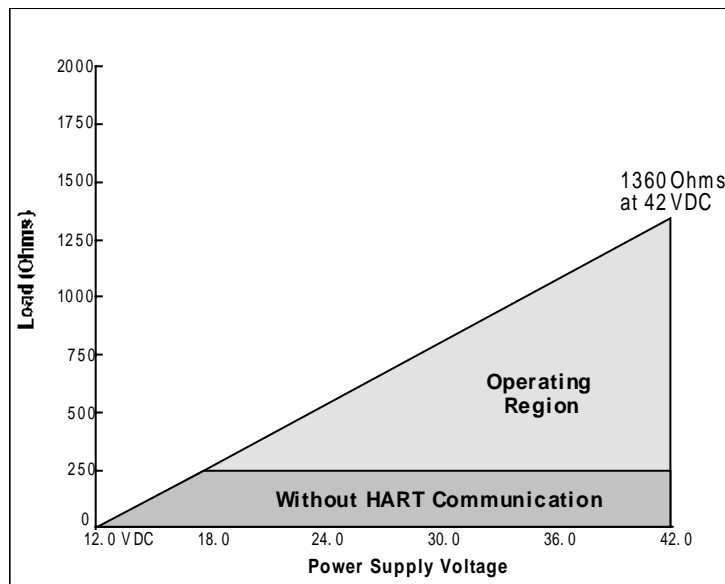

Figure 3 Load/Power Supply Requirements

Communications	
HART Protocol	<ul style="list-style-type: none"> <li>- Digital communication via FSK modulation of the loop current</li> <li>- Point-to-point connection</li> <li>- Reading of measured values, status, messages, and multidrop unit identification</li> <li>- Read and write parameters</li> </ul>
Physical	
Enclosure	Plastic enclosure made of PBT (polybutylene terephthalate) bluish-gray RAL 7031
Mounting	Wall, Pipe, or Panel Mount
Dimensions	H 144 mm, W 144 mm, D 105 mm (H 5.67", W 5.67", D 4.13")
Protection	NEMA 4x, IP65
Cable glands	3 breakthroughs for Pg 13.5 2 breakthroughs for NPT 1/2" or Rigid metallic conduit
Weight	Approx. 1 kg (2.2 lbs)

Area Certifications / Compliances	
General Purpose	Zone 2 (USA) FM: NI, Class I, Div 2, Groups A – D, T4
Intrinsically Safe	Zone 1 (USA) FM: IS, Class I, Div 1, Groups A – D, T4  Zone 1 (Europe) CENELEC: II 2G EEx ib [ia] IIC T6
Data Retention	Parameters and calibration data > 10 years (EEPROM)
RFI Suppression / Immunity to ESD	To EN 50 081-1 and EN 50 081-2
Ambient Conditions	Operation/Environmental temp: (T4) -20 to +55 °C (-4 to +131 °F) (T6) -20 to +40°C (-4 to +104 °F)  Transport and Storage temp: -20 to +70 °C (-4 to +158 °F)

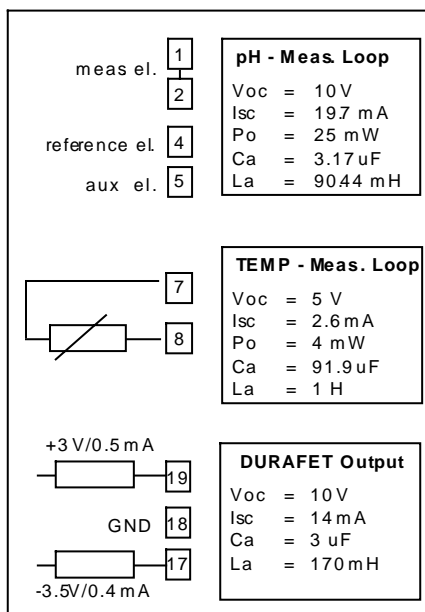

Figure 4 Entity Parameters

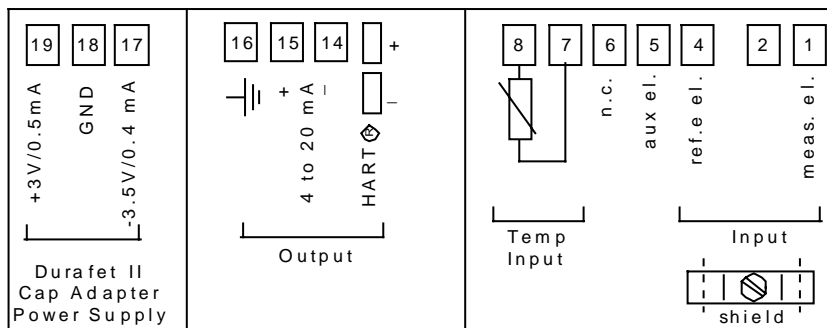

Figure 5 APT2000 pH Terminal Assignments

## Model Selection Guide

### Instructions

- APT2000 Transmitter Offers:
  - Power Requirements - 2 Wire, 14 to 42 VDC
  - Standard - All models CE Compliant
  - Standard - NEMA 4X, IP65
  - Optional - Three mounting types: (must be ordered separately)
    1. Panel Mount Kit
    2. Pipe/Wall Mount Kit
    3. Protective Hood (requires Pipe/Wall Mount Kit)
  - Optional - HART communications
  - Approval Options:
    1. General Purpose; also FM Class I, Div 2, Groups A-D
    2. Intrinsically Safe: FFM Class I, Div 1, Groups A-D
- Select the desired key number. The arrow to the right marks the selection available.
- Make one selection from Tables using the column below the proper arrow.  
A dot (•) denotes unrestricted availability.

Key Number                      I                      II                      III  
 [ ] - [ ] - [ ] - [ ]

KEY NUMBER	Selection	Availability		
<b>Description of Measurement Type</b>				
pH/ORP	APT 2000 PH	↓		
Toroidal (Electrodeless) Conductivity	APT 2000 TC		↓	
Contacting Conductivity	APT 2000 CC			↓

**TABLE I - Communications Protocol**

None (Analog 4 - 20 mA only)	0	•	•	•
HART Protocol	H	•	•	•

**TABLE II - Approvals**

General Purpose; also FM Class I, Div 2, Groups A-D	00	•	•	•
Intrinsically Safe: FM Class I, Div 1, Groups A-D CENELEC EEx ib [ia] IIC T6/T4	IS	•		•

**TABLE III - Optional Equipment**

User's Manual	English	E _ _	•	•	•
Future		_ 0 _	•	•	•
Future		_ _ 0	•	•	•

### Accessory Parts

	Part Number
Mounting Kits:	
Panel Mounting Kit	51205990-001
Pipe/Wall Mounting Kit	51205988-001
Protective Hood (requires pipe/wall kit)	51205989-001
HART Test Socket	51205991-001
Instruction Manual - pH	70-82-25-92
Instruction Manual - Toroidal (Electrodeless) Conductivity	70-82-25-96
Instruction Manual - Contacting Conductivity	70-82-25-95

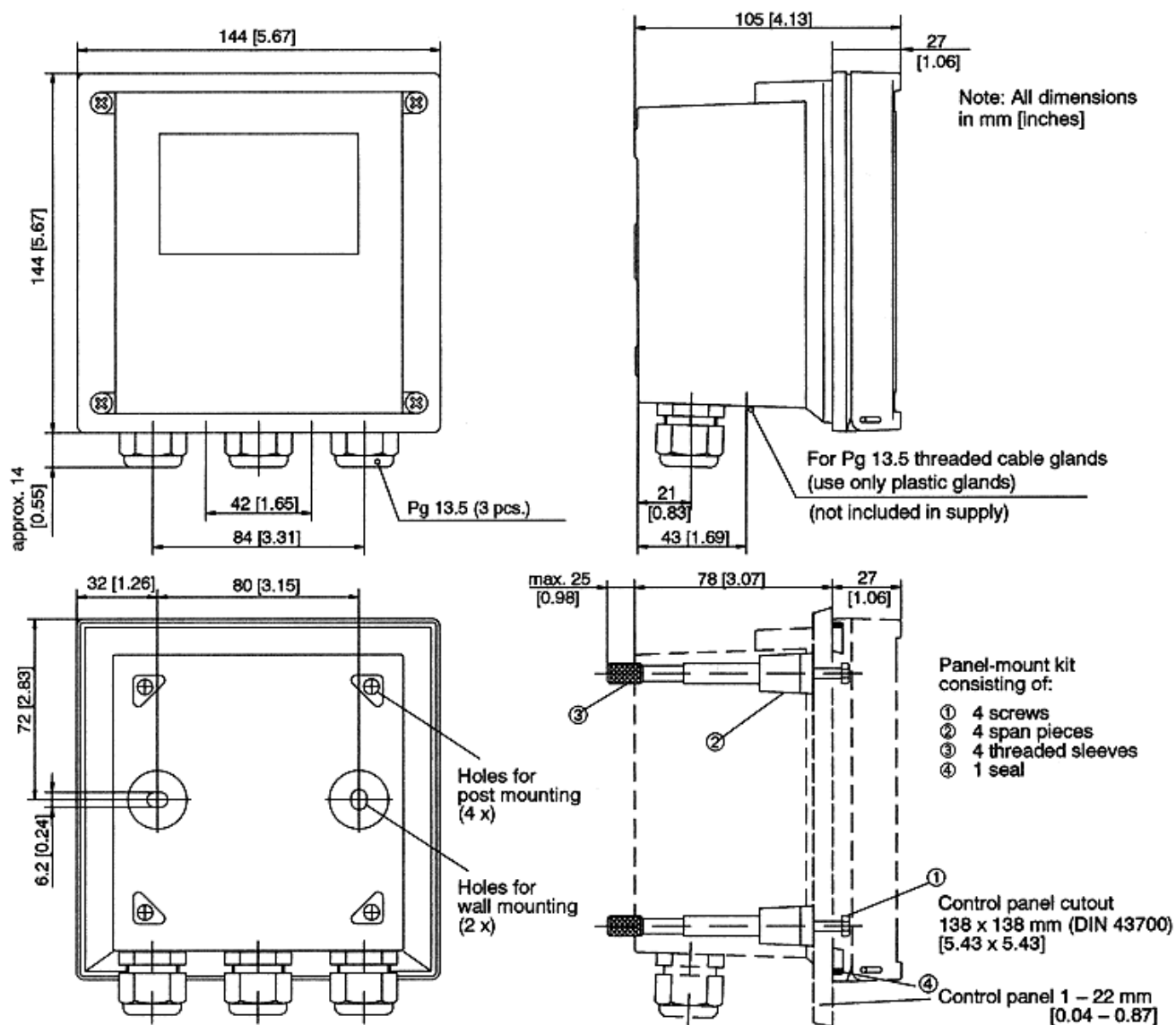

Figure 6 Dimension Drawing for APT2000 and P/N 51205990-001 panel mounting kit

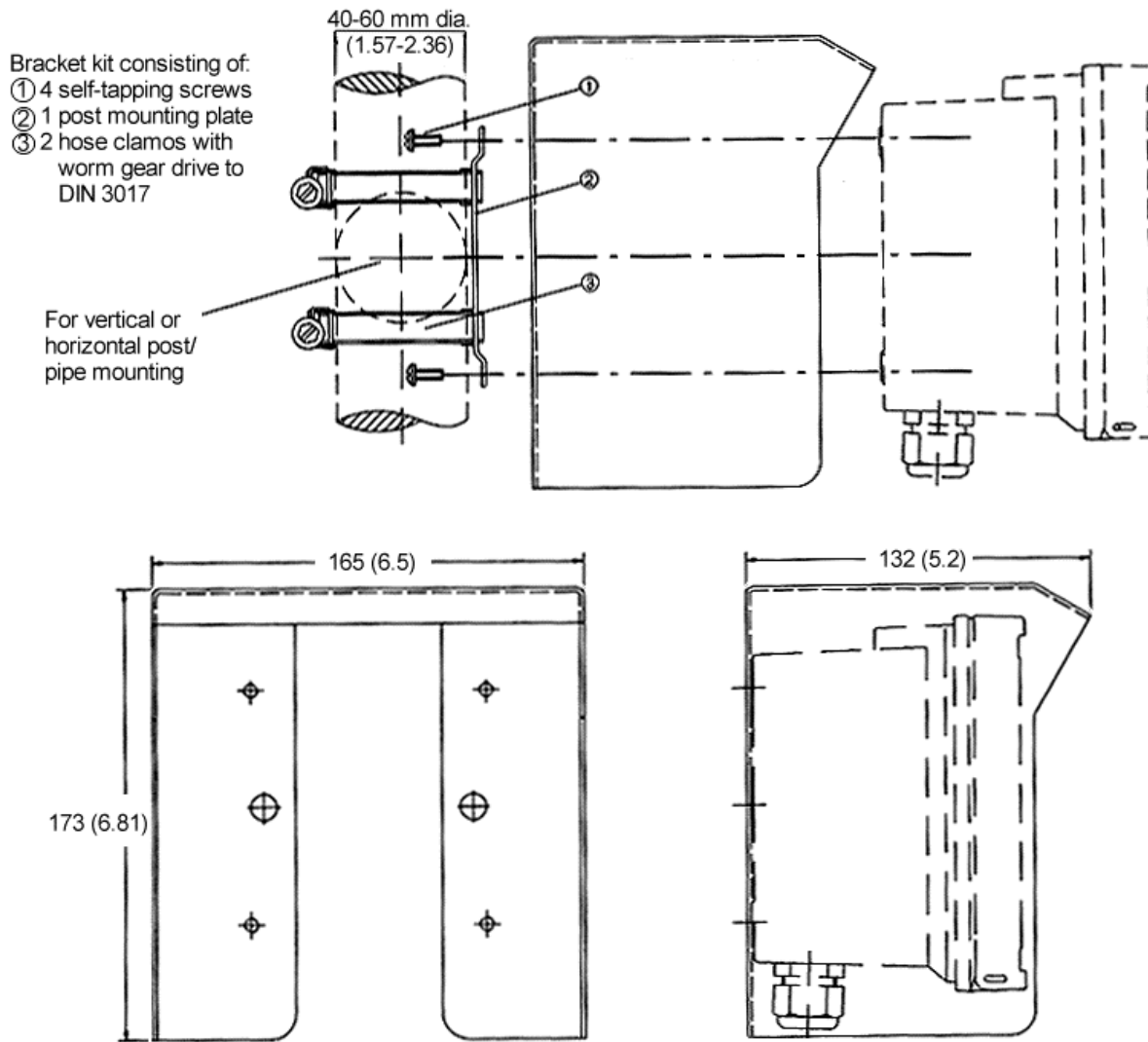

Figure 7 Dimension Drawing for APT2000 with Wall or Pipe Mounting

## WARRANTY/REMEDY

Honeywell warrants goods of its manufacture as being free of defective materials and faulty workmanship. Contact your local sales office for warranty information. If warranted goods are returned to Honeywell during the period of coverage, Honeywell will repair or replace without charge those items it finds defective. The foregoing is Buyer's sole remedy and is **in lieu of all other warranties, expressed or implied, including those of merchantability and fitness for a particular purpose**. Specifications may change without notice. The information we supply is believed to be accurate and reliable as of this printing. However, we assume no responsibility for its use.

While we provide application assistance personally, through our literature and the Honeywell web site, it is up to the customer to determine the suitability of the product in the application.

**Honeywell**

## Sensing and Control

Honeywell  
 11 West Spring Street  
 Freeport, IL 61032