

7866 Single Range Digital Gas Analyzer Operation and Maintenance Manual

70-82-25-111

9/01

Copyright, Notices, and Trademarks

Printed in U.S.A. – © Copyright 2001 by Honeywell

Revision 0 – September 2001

WARRANTY/REMEDY

Honeywell warrants goods of its manufacture as being free of defective materials and faulty workmanship. Contact your local sales office for warranty information. If warranted goods are returned to Honeywell during the period of coverage, Honeywell will repair or replace without charge those items it finds defective. The foregoing is Buyer's sole remedy and is **in lieu of all other warranties, expressed or implied, including those of merchantability and fitness for a particular purpose**. Specifications may change without notice. The information we supply is believed to be accurate and reliable as of this printing. However, we assume no responsibility for its use.

While we provide application assistance personally, through our literature and the Honeywell web site, it is up to the customer to determine the suitability of the product in the application.

CE Conformity (Europe)

This product is in conformity with the protection requirements of the following European Council Directives: **73/23/EEC**, the Low Voltage Directive, and **89/336/EEC**, the EMC Directive. Conformity of this product with any other "CE Mark" Directive(s) shall not be assumed.

Attention

The emission limits of EN 50081-2 are designed to provide reasonable protection against harmful interference when this equipment is operated in an industrial environment. Operation of this equipment in a residential area may cause harmful interference. This equipment generates, uses, and can radiate radio frequency energy and may cause interference to radio and television reception when the equipment is used closer than 30 meters to the antenna(e). In special cases, when highly susceptible apparatus is used in close proximity, the user may have to employ additional mitigating measures to further reduce the electromagnetic emissions of this equipment.

Sensing and Control
Honeywell
11 West Spring Street
Freeport, Illinois 61032

About This Document

Abstract

This manual describes the installation and operation of the 7866 Single Range Digital Gas Analyzer.

Contacts

World Wide Web

The following lists Honeywell's World Wide Web sites that will be of interest to our customers.

Honeywell Organization	WWW Address (URL)
Corporate	http://www.honeywell.com
Sensing and Control	http://www.honeywell.com/sensing
International	http://www.honeywell.com/Business/global.asp













Telephone

Contact us by telephone at the numbers listed below.

	Organization	Phone Number
United States and Canada	Honeywell	1-800-423-9883
		1-888-423-9883
		1-800-525-7439
		Tech. Support Q&A Faxback (TACFAQS) Service
Asia Pacific	Honeywell Asia Pacific Hong Kong	(852) 2829-8298
Europe	Honeywell PACE, Brussels, Belgium	[32-2] 728-2111
Latin America	Honeywell, Sunrise, Florida U.S.A.	(954) 845-2600

Symbol Definitions

The following table lists those symbols used in this document to denote certain conditions.

Symbol	Definition
	This DANGER symbol indicates an imminently hazardous situation, which, if not avoided, will result in death or serious injury .
	This WARNING symbol indicates a potentially hazardous situation, which, if not avoided, could result in death or serious injury .
	This CAUTION symbol may be present on Control Product instrumentation and literature. If present on a product, the user must consult the appropriate part of the accompanying product literature for more information.
	This CAUTION symbol indicates a potentially hazardous situation, which, if not avoided, may result in property damage .
	WARNING PERSONAL INJURY: Risk of electrical shock. This symbol warns the user of a potential shock hazard where HAZARDOUS LIVE voltages greater than 30 Vrms, 42.4 Vpeak, or 60 Vdc may be accessible. Failure to comply with these instructions could result in death or serious injury.
	ATTENTION, Electrostatic Discharge (ESD) hazards. Observe precautions for handling electrostatic sensitive devices
	Protective Earth (PE) terminal. Provided for connection of the protective earth (green or green/yellow) supply system conductor.
	Functional earth terminal. Used for non-safety purposes such as noise immunity improvement. NOTE: This connection shall be bonded to protective earth at the source of supply in accordance with national local electrical code requirements.
	Earth Ground. Functional earth connection. NOTE: This connection shall be bonded to Protective earth at the source of supply in accordance with national and local electrical code requirements.
	Chassis Ground. Identifies a connection to the chassis or frame of the equipment shall be bonded to Protective Earth at the source of supply in accordance with national and local electrical code requirements.
	Earth Ground. Functional earth connection. NOTE: This connection shall be bonded to Protective earth at the source of supply in accordance with national and local electrical code requirements.
	Chassis Ground. Identifies a connection to the chassis or frame of the equipment shall be bonded to Protective Earth at the source of supply in accordance with national and local electrical code requirements.

Contents

1.	INTRODUCTION	1
1.1	Overview	1
1.2	Sensing Unit	2
1.3	7866 Digital Controller	4
1.4	Principles of Operation	7
2.	SPECIFICATIONS AND MODEL SELECTION GUIDE	9
2.1	Specifications	9
2.2	Model Selection Guide.....	12
3.	INSTALLATION	17
3.1	Overview	17
3.2	Sensing Unit Requirements and Location.....	17
3.3	Mounting the Sensing Unit	18
3.4	Piping or Tubing Connections	18
3.5	Mounting the 7866 Digital Controller	21
3.6	Wiring Between Sensing Unit and Digital Controller	24
3.7	Checklist.....	26
4.	SET UP MODE	27
4.1	Overview	27
4.2	Configuration Tips	27
4.3	Unit Set Up Group	28
4.4	Alarms Set Up Group.....	30
4.5	Modbus Communications Set Up Group	31
4.6	Calibration Group	32
4.7	Status Group.....	32
5.	CALIBRATION	33
5.1	Overview	33
5.2	Sensing Unit Calibration.....	33
5.3	7866 Input Calibration	34
5.4	Output Calibration.....	36
5.5	Security Lockout	37
5.6	Setting the Alarm Limits.....	39

6.	OPERATION	41
6.1	Overview	41
6.2	Operating Notes	41
6.3	Operation.....	41
7.	MAINTENANCE	43
7.1	Routine Maintenance	43
7.2	Parts Replacement.....	43
7.2.1	Sensing Unit.....	43
7.3	Repacking.....	46
7.4	Spare Parts.....	47
8.	TROUBLESHOOTING	49
8.1	Overview	49
8.2	Troubleshooting	49
8.2.1	General.....	49
8.2.2	Recalibration.....	49
8.2.3	Fault Isolation Tests.....	51
8.2.4	Additional Troubleshooting.....	55
9.	APPENDIX A – SECURITY BYPASS	57
9.1	Overview	57

Tables

Table 1-1	Function of Keys	5
Table 1-2	Relative Thermal Conductivity of Common Gases	7
Table 4-1	Configuration Tips	27
Table 4-2	Unit Group Function Prompts	28
Table 4-3	Alarms Group Function Prompts	30
Table 4-4	Modbus Communications Group Function Prompts.....	31
Table 4-5	Status Group Function Prompts	32
Table 5-1	Input Calibration for Range 1	34
Table 5-2	Restoring Factory-set Input Calibration Values.....	35
Table 5-3	Output Calibration Procedure	36
Table 5-4	Entering the Security Code	37
Table 5-5	Changing Security Level.....	38
Table 5-6	Alarm Adjustment Procedure.....	40
Table 7-1	Sensing Unit Cell Assembly Cable Connections	45
Table 7-2	Recommended Spare Parts.....	47
Table 8-1	Coarse Zero Adjustment	50
Table 8-2	Binary Count Sequence for Coarse Zero Jumper Pattern	50
Table 8-3	Coarse-Zero Jumper Pattern.....	51
Table 8-4	Troubleshooting Procedures	52

Figures

Figure 1-1	7866 Digital Analyzer.....	1
Figure 1-2	Sensing Unit, Showing Removal of Entire Sensing Assembly	3
Figure 1-3	7866 Digital Controller, Front View	5
Figure 1-4	Single-Range Gas Analyzer Controller and Display Logic Chart	6
Figure 3-1	Outline and Mounting Dimensions for Sensing Unit	20
Figure 3-2	7866 Digital Controller Dimensions.....	22
Figure 3-3	Mounting Method for Controller	23
Figure 3-4	Interconnections Between Digital Controller and Sensing Unit.....	25
Figure 7-1	Sensing Unit Mother and Daughter Circuit Cards Parts List	44
Figure 7-2	Gas Inlet and Outlet Fitting Parts	46

1. Introduction

1.1 Overview

The 7866 Analyzer consists of three basic components: the sensing unit (transmitter), the control unit (receiver)—both shown in Figure 1-1—and a power supply. The sensing unit is located at the sampling site; the 7866 Digital Controller is arranged for panel mounting in a non-hazardous area.

The sensing unit receives a continuous flow of the binary or multi-component gas mixture, measures the concentration of the sample gas and transmits an electrical signal to the control unit. The sensing unit is ruggedly constructed to meet most environmental conditions and is designed to be mounted up to 1,000 feet from the control unit with only a single multi-conductor non-shielded cable connecting the two, resulting in greater flexibility and lower installation costs.

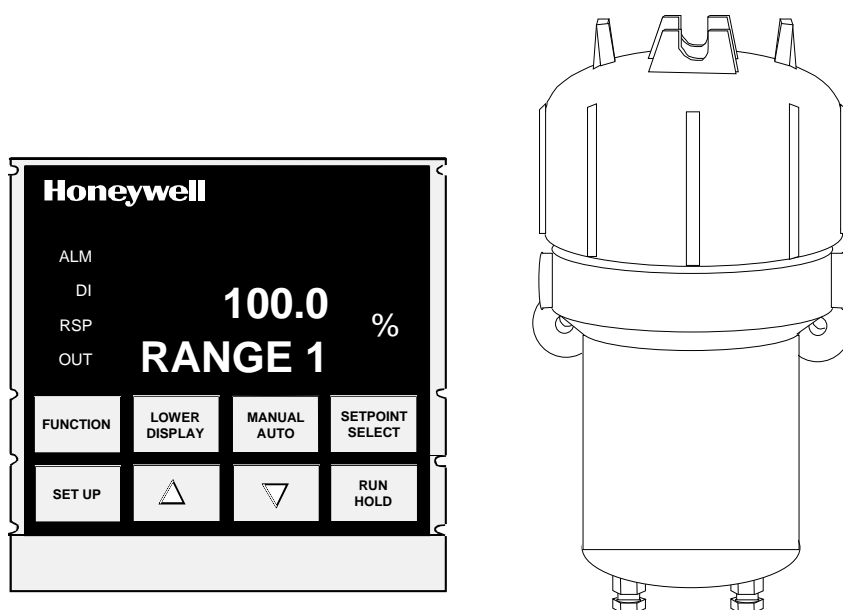

Figure 1-1 7866 Digital Analyzer

The control unit receives the output signal from the sensing unit at the sampling site by way of the interconnecting cable. The control unit is designed for simplified panel-mounting either at the sampling site, if environmental conditions permit, or in a control room. The unit can provide a current output signal to a remote device for monitoring or recording purposes. The control unit is supplied with one or two alarms. When an alarm is detected, the specific relay de-energizes, creating an open circuit that can activate an external annunciator or a relay to initiate a shutdown procedure for the process. When power is off the alarm relay is de-energized.

1.2 Sensing Unit

The 7866 Thermal Conductivity Analyzer's Sensor Assembly is supplied in an explosion proof housing. The housing consists of a rugged cast aluminum construction that permits reliable operation under adverse ambient conditions.

The Sensor Assembly consists of two sections – the cell block assembly and the electronic assembly (Figure 1-2).

The Cell Block assembly is constructed of stainless steel with two identical internal cells, the measuring cell and the reference cell. The highly stable thermistor is mounted in each cell. These matched thermistors form the active arms of a bridge circuit; the unbalanced current of the bridge provides the means of measuring the relative ability of the sample and reference gases to conduct the heat away from their respective thermistors to the cell wall, which is held at a constant temperature.

The reference gas chamber, with inlet and outlet openings drilled into the chamber from the base, can be opened or sealed. All zero-based standard ranges and the 20 % to 50 % H₂ Range have air-filled, sealed reference cells. For hydrogen ranges starting above 50 % as well as the 90-100 % oxygen range, a flowing reference is used. The measuring chamber is open to the continuous sample gas flow.

The cells in which the thermistors are mounted are dead-ended so the sample gas enters only by diffusion, minimizing the effect of sample flow variations. In addition, the entire cell-block assembly is maintained at a constant optimum temperature through two heaters and a control thermistor that are located in the cell block assembly.

The Sensing Unit's electronics assembly incorporates solid state electrical circuits. These circuits include:

- *Current Regulator*: supplies the constant current to the thermistor cell bridge circuit.
- *Proportional Action Temperature Controller*: maintains the entire cell block at a constant temperature.
- *Voltage to Current Converter/Amplifier*: its current output is transmitted to the analyzer's Control Unit.

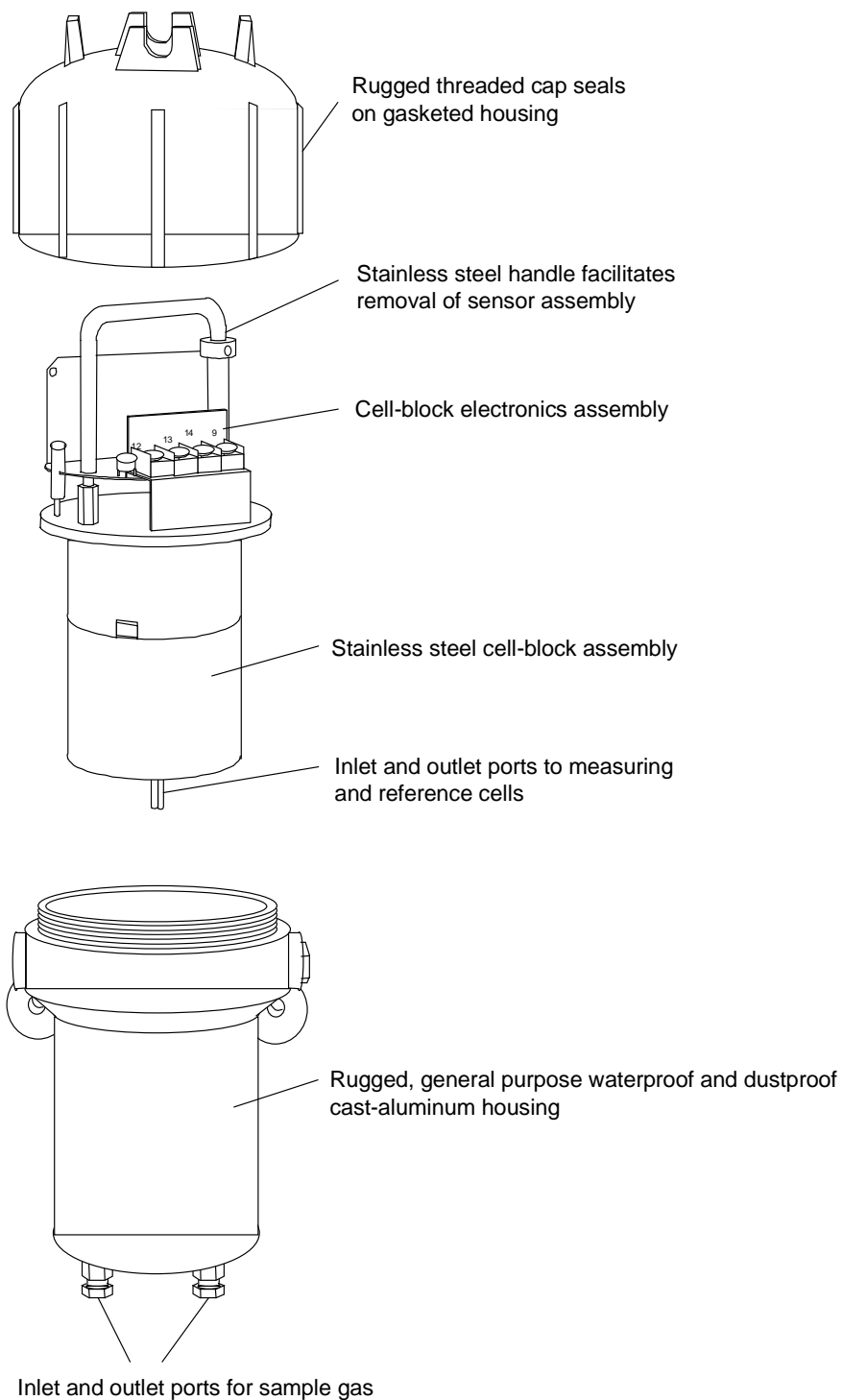

Figure 1-2 Sensing Unit, Showing Removal of Entire Sensing Assembly

1.3 7866 Digital Controller

The 7866 Digital Controller shown in Figure 1-3 can provide a current output, a digital display of the measured gas percentage, and up to two alarm circuits. The alarm limits are set using the integral keyboard on the face of the instrument.

The unit also provides access to the calibration settings for the range. The zero and span setting are entered using the CALIB group prompts. Zero and span are "live" readings until the FUNCTION key is pressed, at which time that displayed value is captured. The ▲/▼ keys can then be used to change the desired value. These values are normally secured from inadvertent or unauthorized tampering using a four-digit security code.

If alarms are in use, the 7866 Digital Controller displays the alarm status. The alarms are listed by number on the left side of the display.

If the alarm is in force, the number "1" or "2" will be lit indicating the respective alarm and process violation. These alarms will de-energize output relays that the user may hardwire to annunciation circuits or to a safety shutdown system depending on the application. Alarm limits are adjusted through the ALARMS Set Up group. The security feature can also secure alarm limits.

Normal power losses, even over extended time periods, will not affect the configuration of the controller. The controller uses a non-volatile memory system to secure the controller's current configuration and calibration settings. This will prevent any loss during outages.

The factory calibration constants that can be used with the controller are stored in its nonvolatile memory. If a field calibration is lost, you can quickly restore the "factory calibration" and overwrite any previous field calibration. Protection after calibration is available through the LOCKOUT feature.

The controller's circuit boards are accessible for service and replacement. The modular design permits selective replacement of circuits as required. The removable chassis eliminates the need to remove or change any field wiring for a circuit board or controller change.

The rear of the controller has three terminal strips for field wire termination. All field terminations are accessible from the rear of the controller. Stranded wire of 20 to 22 gauge is recommended. See wiring section for more specific instructions.

The 7866 Digital Controller features a universal power supply that can be connected to line voltages of 90 Vac to 264 Vac or 24 Vac/dc. The line frequency can be 50 hertz or 60 hertz.

Power for the 7866 Sensing Unit is supplied by a separate 30 Volt dc power supply. This power supply is also utilized by the controller to power its interconnections with the sensing unit.

Upper Display - six characters

- Normal Operation - four digits dedicated to displaying the process variable (Decimal place is selectable to either 1 or 2 places)
- Configuration Mode - displays parameter values or selection

Lower Display - eight characters

- Normal Operation - displays RANGE 1 or the gas prompt
- Configuration Mode - displays the group or function prompt

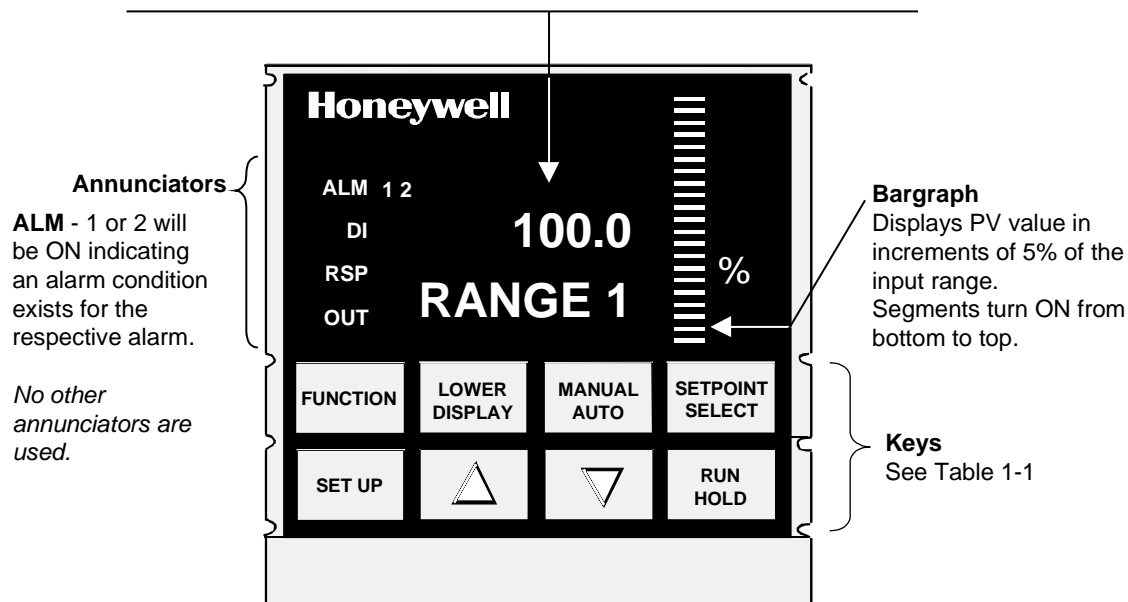

Figure 1-3 7866 Digital Controller, Front View

Table 1-1 Function of Keys

Key	Function
SET UP	<ul style="list-style-type: none"> • Places the controller in the Configuration Set Up group select mode. Sequentially displays Set Up groups and allows the FUNCTION key to display individual functions in each Set Up group.
FUNCTION	<ul style="list-style-type: none"> • Used in conjunction with the SET UP key to select the individual functions of a selected Configuration Set Up group. • Pressing this key saves, into nonvolatile memory, any changes made to previous function value or selection. • Used during field calibration procedure.
▲	<ul style="list-style-type: none"> • <i>Configuration Mode</i>: Used to scroll through parameter selections or to increase the selected parameter value.
▼	<ul style="list-style-type: none"> • <i>Configuration Mode</i>: Used to scroll through parameter selections or to decrease the selected parameter value.
Changing Values Quickly	When changing the value of a parameter, you can adjust a more significant digit in the upper display by holding in one key (▲ or ▼), and pressing the other (▲ or ▼) at the same time. The adjustment will move one digit to the left. Press the key again and you will move one more digit to the left.
LOWER DISPLAY	<ul style="list-style-type: none"> • Used to toggle between RANGE 1 and the Input Type [e.g., PC H2 (Percent Hydrogen)] during normal operation.

Key	Function
MANUAL AUTO SETPOINT SELECT RUN HOLD	<ul style="list-style-type: none"> Unused keys KEY ERR message will appear in lower display if one of these keys is pressed.

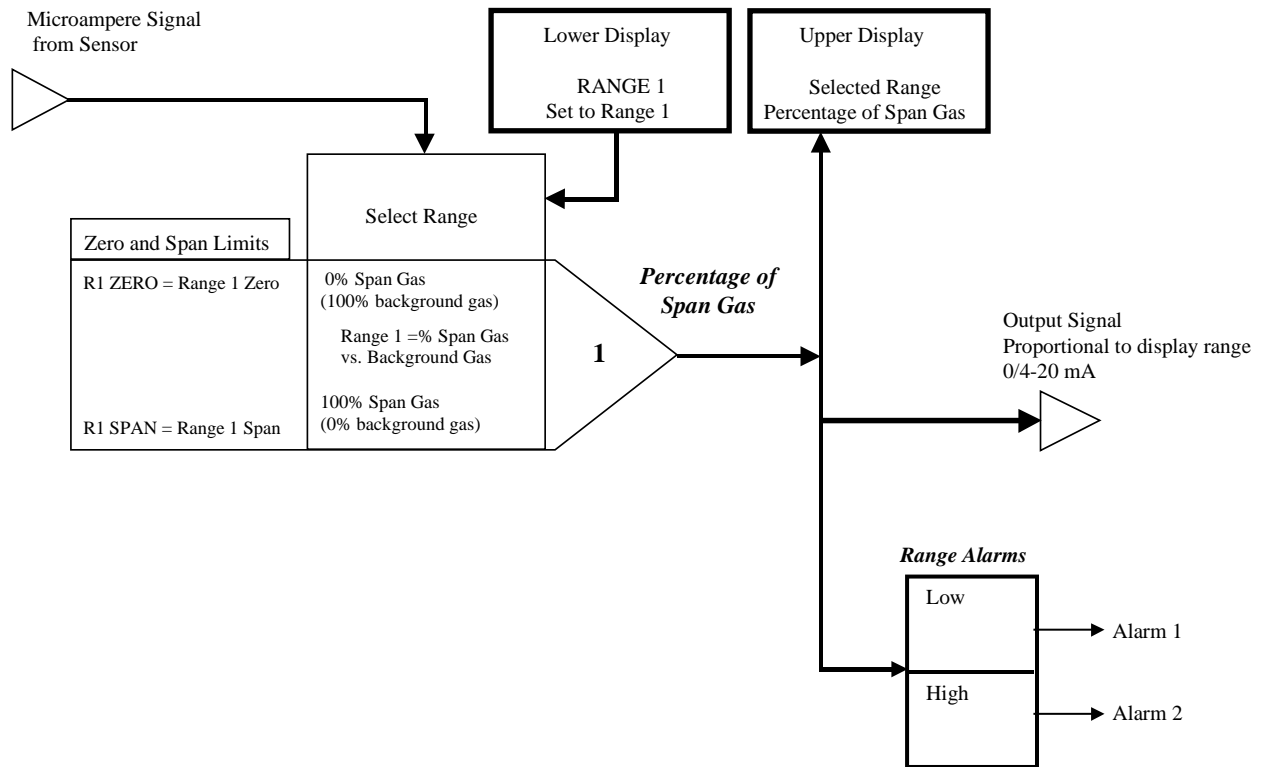

Figure 1-4 Single-Range Gas Analyzer Controller and Display Logic Chart

1.4 Principles of Operation

Thermal Conductivity Principles

Although basic thermal conductivity principles need not be included here, it may be appropriate to consider the following expressions.

Thermal Conductivity of Gas

The thermal-conductivity of a gas mixture is approximately the sum of the products of the mole fractions of each gas mixture. Therefore, using the letter K to represent thermal conductivity, a gas mixture of 15 % CO₂ in air can be defined by the following expression:

$$K_{\text{mix}} = 0.85 K_{\text{air}} + 0.15K_{\text{CO}_2}$$

Thermal Conductivity of Air

Expressing thermal conductivities in air can be defined by the following expression:

$$K_{\text{air}} \text{ is } 1.00 \text{ and } K_{\text{CO}_2} \text{ is } 0.704. \text{ Therefore}$$

$$K_{\text{mix}} = 0.85 \times 1 + 0.15 \times 0.704 = 0.91.$$

Temperature Difference

Using a thermistor as the detector in a sample gas and another thermistor in the reference gas, the difference in temperature of these two detectors can be estimated when the thermal conductivities of the gas mixture of the sample gas and reference gas are known. This temperature difference can be expressed as follows:

$$t = \frac{K_{\text{ref}} - K_{\text{mix}} \times (t_1 - t_2)}{K_{\text{mix}}}$$

Where t₁ is the reference thermistor temperature and t₂ is the cell-block temperature. The above expression applies only when the measuring and reference thermistors are heated to at least 120 °C, which is the minimum temperature for which these thermistors will linearly sense thermal conductivity changes. It applies when current input is constant and the heat losses are by thermal conductivity only.

Common Gases

Table 1-2 lists the common gases which can be measured by this method or can be present as components in the background gas of the mixture being measured. All thermal conductivities are referred to air at 120 °C.

Table 1-2 Relative Thermal Conductivity of Common Gases

Component	Thermal Conductivity (K)	Component	Thermal Conductivity (K)
Air	1.000	Cl ₂	0.342
O ₂	1.028	SO ₂	0.350
NH ₃	1.040	H ₂ S	0.540
CH ₄	1.450	Ar	0.665
He	5.530	CO ₂	0.704
H ₂	6.803	H ₂ O	0.771
		CO	0.958
		N ₂	0.989

2. Specifications and Model Selection Guide

2.1 Specifications

Performance	
Accuracy	± 2 % of span (output signal) at reference conditions for binary gas mixtures
Linearity	Within ± 2 % of span for most standard ranges. If linearity exceeds ± 2 % a correction curve is supplied with the analyzer.
Meter	<i>Accuracy:</i> ± 2 % of span <i>Digital Indication:</i> ± 0.1 %
Repeatability	Short term: ± 0.3 % of span
Reproducibility	24 hour: ± 1 % of span
Response Time	Maximum, for 4 cfh (2000 cc/min.) flow: For H ₂ ; initial, less than 1 second; 63 %: 13 seconds 90 %: 23 seconds 99 %: 40 seconds For CO ₂ ; Initial, less than 2 seconds; 63 %: 24 seconds 90 %: 45 seconds 99 %: 80 seconds
Maximum Drift	<i>Zero:</i> ± 2 % of span/week maximum <i>Span:</i> ± 2 % of span/week maximum
Ambient Temperature Influence	<i>At sensing unit:</i> Depends on range; typically less than 1 % F.S. over entire temperature range <i>At control:</i> ± 0.01 % per °C (± 0.005 % of span per °F)
Atmospheric Pressure Influence	± 0.1 % of span per inch H ₂ O (± 0.05 % per mm Hg)
Sample Flow Rate Influence	Less than ± 0.5 % of span over flow range of 0.2 cfh to 4 cfh (100 cc/min to 2000 cc/min)
Line Voltage Influence	Maximum 0.02 % of span for each 1 % change of line voltage

Specifications (continued)	
Operating	
Measuring Range	One range, as specified. For standard ranges, see Selection Guide Table in the Model Selection Guide.
Output Ranges	0-20 mA maximum load: 800 ohm 4-20 mA maximum load: 800 ohm
0/4-20 mA Output	0/4 mA at low range limit 20 mA at high range limit
Alarm Outputs	Two alarms are available; each uses an SPDT electromechanical relay. Alarm Relay Contacts Rating <i>Resistive Load: 5 amps @ 24 Vdc or 120 Vac or 240 Vac</i> <i>Inductive Load: 50 VA</i>
Outputs	Two relay outputs for Alarm 1 and Alarm 2 One current output that represents value of PV.
Sample Requirements	<i>Sample Flow: 0.2 cfh to 4.2 cfh (100 cc/min to 2000 cc/min)</i> <i>Sample Pressure: 37 mm Hg (20" H₂O) minimum (with filter and flowmeter)</i>
Reference Gas Requirements	None required, except for ranges 095000, 098000, 500006, 512000, and 516000; these require pure hydrogen reference gas flow, 0.02-0.2 cfh (10-100 cc/min).
Ambient Requirements	<i>Relative Humidity: 90 % maximum</i> <i>Temperature Range: -10 °C to +50 °C (14 °F to 122 °F)</i> <i>Storage Temperature: 70 °C maximum (158 °F)</i>
Power Requirements	<i>Control Unit only: Universal supply 90 Vac to 264 Vac (consumption 18 VA maximum) or 24 Vac/dc (consumption 12 VA maximum); 50 Hz to 60 Hz</i>
Materials Contacting Sample Gas	Sample contacts 316 stainless steel, Buna N, Teflon, glass and Viton
Connections	<i>Sample inlet and outlet: ¼" OD tubing (compression fittings supplied)</i> <i>Reference gas inlet and outlet: ¼" OD tubing (compression fittings supplied)</i> <i>Electrical power inlet: Opening for ½" conduit (control unit only)</i> <i>Sensing unit power inlet (24 Vdc from control unit): ½" NPT (female conduit)</i>
Communications (optional):	<i>Link Characteristics: Two-wire multi-drop Modbus RTU protocol, 15 drops maximum or up to 31 drops for shorter link length</i> <i>Distance: 4000 feet maximum</i> <i>Baud Rate: 2400 baud, 4800 baud, 9600 baud, or 19.2K baud selectable</i> <i>Data Format: Floating point or integer</i> <i>Parity: Selectable odd or even</i>

Specifications (continued)	
Physical Specifications	<p>Sensing Unit: <i>Weight:</i> Explosion proof – 8.5 kg (18-3/4 lb.) <i>Dimensions:</i> Explosion proof – Approximately 150 mm x 150 mm x 325 mm (6 in. x 6 in. x 12-3/4 in.)</p> <p>Control Unit: <i>Weight:</i> 1.3 kg (3 lb.) <i>Dimensions:</i> Bezel: 96 mm H x 96 mm W (3.78" H x 3.78" W) Case: 92 mm H x 92 mm W x 192 mm D (3.62" H x 3.62" W x 7.55" D)</p>
Standards – Sensing Unit	<i>Explosion-proof sensing unit:</i> Designed to meet NEMA 7, Class 1, Division 1, Groups A, B, C and D
Standards – Control Unit	<p>This product is in conformity with the protection requirements of the following European Council Directives: 73/23/EEC, the Low Voltage Directive, and 89/336/EEC, the EMC Directive. Conformity of this product with any other "CE Mark" Directive(s) shall not be assumed.</p> <p><i>Product Classification:</i> Class I: Permanently connected, panel-mounted Industrial Control Equipment with protective earthing (grounding). (EN61010-1).</p> <p><i>Enclosure Rating:</i> Panel-mounted equipment, IP 00. This controller must be panel-mounted. Terminals must be enclosed within the panel. Front panel IP 65 (IEC 529).</p> <p><i>Installation Category (Overvoltage Category):</i> Category II: Energy-consuming equipment supplied from the fixed installation, local level appliances, and Industrial Control Equipment. (EN61010-1)</p> <p><i>Pollution Degree:</i> Pollution Degree 2: Normally non-conductive pollution with occasional conductivity caused by condensation. (Ref. IEC 664-1)</p> <p><i>EMC Classification:</i> Group 1, Class A, ISM Equipment (EN55011, emissions), Industrial Equipment (EN50082-2, immunity)</p> <p><i>Method of EMC Assessment:</i> Technical File (TF)</p> <p><i>Declaration of Conformity:</i> 51309602-000</p>
Miscellaneous	<i>Analyzer temperature:</i> Sensing unit thermostated at 50 °C (122 °F)
Environmental and Operating Conditions	
Temperature Range	<p><i>Typical:</i> 15 °C to 55 °C (58 °F to 131 °F) <i>Extreme:</i> 0 °C to 55 °C (32 °F to 131 °F)</p>
Relative Humidity	<p><i>Typical:</i> 10 % to 90 % <i>Extreme:</i> 5 % to 90 %</p>
Vibration	<p><i>Typical:</i> 0.1 g acceleration between 0 Hz and 70 Hz <i>Extreme:</i> 0.5 g acceleration between 0 Hz and 200 Hz</p>

2.2 Model Selection Guide

51-52-16-78

Issue 1

Instructions

- Select the desired key number. The arrow to the right marks the selection available.
- Make one selection from Tables using the column below the proper arrow.
A dot (•) denotes unrestricted availability.

Key Number I II III IV V
 [-----] - [] - [] - [] - [] - [] -

 VI VII VIII
 [] - [] - []

KEY NUMBER	Description	Selection	Availability
7866	Digital Thermal Conductivity Gas Analyzer consisting of: a) 07866DS2 Sensor Assembly (includes housing) b) 07866DC2 Digital Control Unit	07866DO2	↓
7866	Replacement Digital Control Unit <i>Only</i>	07866DC2	↓
7866	Replacement Sensor Assembly - 2 Port (<i>Electronics Only</i>)	07866SS2	↓
7866	Replacement Sensor Assembly - 4 Port (<i>Electronics Only</i>)	07866SS4	↓

TABLE I - SENSOR POWER SUPPLY/LINE VOLTAGE

None	0	•	•	•
Input Voltage 105 - 125 VAC, 50 - 400 Hz.	2	•	•	
Input Voltage 210 - 250 VAC, 47 - 520 Hz.	4	•	•	

TABLE II - OUTPUT (PV RANGE)

None	0	•	•	•
0-20 mA	1	•	•	
4-20 mA	2	•	•	

TABLE III - COMMUNICATIONS

None	000	•	•	•
RS422/485/MODBUS	101	•	•	

TABLE IV - BACKGROUND GAS (Note: *On replacement control unit chassis, selection must be same as selection on original unit*)

Air, N ₂ , CO ₂ , or O ₂ where component being measured is % H ₂	1	j	j	j
Air, N ₂ , or O ₂ where component being measured is % CO ₂	2	k	k	k
H ₂ where component being measured is % O ₂	4	l	l	l
Air where component being measured is % He	5	m	m	m

TABLE V - RANGE (Note: On replacement control unit chassis, selection must be the same as selection on original unit)

		0	0	0	0
		7	7	7	7
		8	8	8	8
		6	6	6	6
		6	6	6	6
		D	D	S	S
		O	C	2	4
	Selection	2	2	2	4
When measuring % H ₂ in Air, N ₂ , or O ₂ ; % H ₂ @:					
0-1	001000	c	•	•	
0-2	002000	c	•	•	
0-5	005000	c	•	•	
0-10	010000	c	•	•	
0-15	015000	c	•	•	
0-20	020000	c	•	•	
0-30	030000	c	•	•	
0-75	575000	c	•	•	
0-100	503000	c	•	c	
50-100	103000	h	•		•
80-100	080000	h	•		•
85-100	516000	h	•		•
90-100	506000	h	•		•
95-100	095000	h	•		•
98-100	098000	h	•		•
60-80	515000	c	•	•	
40-80	548000	c	•	•	
45-55	514000	c	•	•	
20-50	050000	c	•	•	
When measuring % CO ₂ in Air, N ₂ , or O ₂ ; % CO ₂ @:					
0-10	010000	c	•	•	
0-15	015000	c	•	•	
0-20	020000	c	•	•	
0-30	030000	c	•	•	
0-40	518000	c	•	•	
0-100	519000	c	•	•	
When measuring 0-100 % H ₂ in CO ₂	111000	c	•	•	
When measuring 70-100 % He in Air	510000	h	•		•
When measuring 95-100 % O ₂ in H ₂	090000	c	•	•	
Special application: 0-75% dissociated ammonia	075000	c	•	c	

Table VI - SENSOR UNIT

None	0		•		
Sealed Reference - 2 Port Explosion Proof	3	•		•	
Flowing Reference - 4 Port Explosion Proof	7	•			•

0	0	0	0
7	7	7	7
8	8	8	8
6	6	6	6
6	6	6	6
D	D	S	S
O	C	2	4
2	2	2	4

TABLE VIII - OPTIONS

	Selection				
None	000	•	•	•	•
Linen Tags: 15 characters max. On each of three lines: Specify legend. One mounted on control Unit. One on Sensing Unit	206	•	•	•	•
Stainless Steel Tag: 15 characters max. On each of three lines: Specify legend. One mounted on control Unit. One on Sensing Unit	208	•	•	•	•

ACCESSORY PARTS

Description	Part Number
Power Supply - Input Voltage 105-125VAC, 50-400 Hz	51450915-501
Power Supply - Input Voltage 210 -250VAC, 47-520 Hz	51450915-502
DIN Adaptor Plate	30755223-002

RESTRICTIONS

Restrictions Letter	Available Only With		Not Available With	
	Table	Selection	Table	Selection
c	VI	3		
h	VI	7		
j			V	090000, 510000, 518000, 519000
k	V	010000, 015000 20000, 030000 518000, 519000		
l	V	090000		
m	V	510000		

SELECTION GUIDE (Note 1)

Single % Range (no price adder)	Measurement Component	Background	Table IV Background Gas Code	Table V Range	Table VI Sensing Unit
0-1	% H ₂	Air or N ₂ or O ₂	1	001000	3
0-2				002000	
0-5				005000	
0-10				010000	
0-15				015000	
0-20				020000	
0-30				030000	
0-75				575000	
0-100				503000	
50-100				103000	
80-100				080000	
85-100				516000	
90-100				506000	
95-100				095000	
98-100				098000	
60-80				515000	
40-80				548000	
45-55	514000				
20-50	050000				
0-10	% CO ₂	Air or N ₂ or O ₂	2	010000	3
0-15				015000	
0-20				020000	
0-30				030000	
0-40				518000	
0-100				519000	
0-100				111000	
70-100	510000				
95-100	090000				
0-75 dissociated ammonia	% H ₂	N ₂	1	075000	3
Triple Range: For hydrogen cooled generator applications, See GA-21 for pricing on 7866DHH2 and GA-3 for <i>Optional</i> 7872 Sampling System.					

NOTES:

1. This Selection Guide is included to assist in the model selection process for 7866 Digital Thermal Conductivity Gas Analyzers.

3. Installation

3.1 Overview

This section describes the installation requirements and procedures for the Sensing Unit and the Digital Controller.

3.2 Sensing Unit Requirements and Location

Location

Locate the sensing unit as close as possible to the sampling probe to minimize response lag. This should be at a point in the gas stream which best represents the true gas composition. An ac power line is not required. The sensing unit can be located in a protected outdoor area. The housing is watertight; but it should not be exposed to direct rays from the sun. Ambient temperature must not go above 50 °C (122 °F) or below -10 °C (14 °F).

Connections

Provide a three-conductor copper-wire cable (four-conductor if a solenoid calibrate valve is used) to provide the connections between the sensing unit and the 7866 Digital Controller. The required wire size for each conductor is listed in Section 2.1 according to cable length. An adapter is supplied to terminate 1/2 inch threaded conduit and connect to the sensing unit watertight housing. The explosion-proof housing is tapped for 1/2 NPT conduit.

Clearance

Provide at least 12 inches clearance above the top of the sensing unit to allow the internal assembly to be removed for servicing. Allow appropriate space below the sensing unit for 1/4 inch or 6 mm inlet and outlet tubing connections. Position the sensing unit on a vertical surface with the inlet and outlet fittings at the bottom. Allow space at the right-hand opening for the solenoid calibrate valve, which, if supplied, is to be mounted here.

Sampling System

Provide a sampling system to deliver a clean and relatively dry sample at a rate of 100 to 2000 cc per minute. The sample should be free of dust.

Calibrating Gases

Provide a source of calibrating gases; e.g., cylinders of compressed zero gas and span gas with pressure regulating valves on each. In general, a zero gas contains all gas components in the sample stream except the measured gas. For suppressed-zero ranges, zero gas contains measured gas at or slightly above the low-end value. Concentrations should be those normally present in the stream. A span gas contains all of the gases in the sample stream at expected concentrations with measured gas concentration accurately analyzed. Concentration of water (vapor) in the calibrating gas should be the same as that in the background gas. Therefore, a gas saturator or dryer may be required.

Reference Gas

Provide a source of reference gas, if required. If hydrogen or helium, supply at 0.02 cfh to 0.2 cfh (10 cc/min to 100 cc/min). Vent to atmospheric pressure. (If hydrogen, vent to a safe ventilating system.). If flowing air is required, supply at 0.5 cfh to 2.0 cfh (250 cc/min to 1000 cc/min). Vent to atmospheric pressure.

3.3 Mounting the Sensing Unit

Explosion-Proof Housing

WARNING

EXPLOSION-PROOF SENSING UNIT REQUIREMENTS

- Always use conduit for electrical wiring and follow special installation procedures.
- Make certain fully qualified personnel make this installation and all local regulations are observed.

Failure to comply with these instructions could result in fire caused by explosion inside the housing.

The sensing unit is designed as explosion-proof. Dimensions for this unit are shown in Figure 3-1. Electrical conduit must be used for all wiring and the openings are fitted for 1/2-inch conduit.

Mount the explosion-proof sensing unit in accordance with Figure 3-1.

3.4 Piping or Tubing Connections

Inlet and Outlet Connections

The O-ring type compression fittings in the base of the sensing unit will accept plastic or metal tubing having an O.D. between 0.236 inches (6 mm) and 0.255 inches (6.5 mm). Make inlet and outlet connections in accordance with Figure 3-1.

Types of Tubing

Any metal and most plastic tubing can be used provided it is chemically compatible with the sample gas. Avoid the use of plasticized PVC or other soft tubing at the sensing-unit compression fittings and do not use tubing having an inside diameter less than 4 mm.

Outlet Line Connection

To maintain the analyzer cell at constant pressure under various flow conditions, the outlet line must be less than two meters (six feet) long and should exit to atmospheric pressure. No restrictions (other than a Rotameter-type flowmeter) can be used in this line. If a longer vent line is required, use larger diameter tubing, e.g., 12 mm (1/2") O.D.

Making Connections

CAUTION

CONNECTION DAMAGE

- Excessive tightening on metal tubing may damage the O-ring.
- Excessive tightening on plastic tubing may restrict the opening.

Failure to comply with these instructions may result in product damage.

Step	Action
1	Cut the tubing squarely and remove all burrs, loosen the compression nut.
2	Then push the tubing firmly into fitting until it slips through the O-ring and seats against the metal.
3	Tighten the compression nut by hand; then turn it about 1/8 turn with a wrench. If the entire fitting assembly turns, use a back-up wrench.
4	If a good seal does not result, remove the compression nut and slide it onto the tubing, take out the small O-ring and slip it on the tubing, then assemble the fitting.

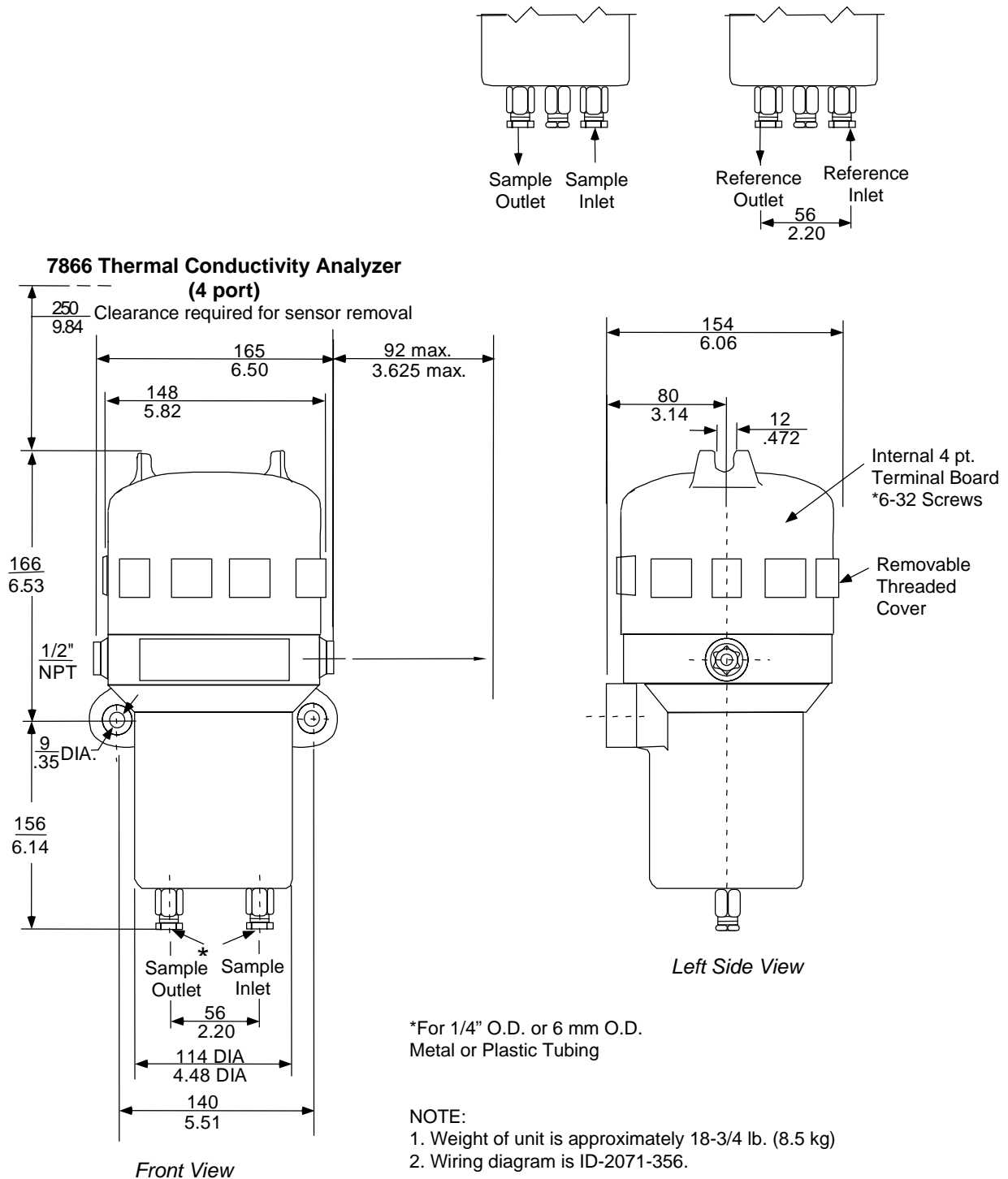

Figure 3-1 Outline and Mounting Dimensions for Sensing Unit

3.5 Mounting the 7866 Digital Controller

Introduction

The 7866 Digital Controller can be mounted on a panel using the mounting kit supplied. Adequate space must be available at the back of the panel for installation and servicing activities.

▲ NOTICE

The controller is considered "rack and panel mounted equipment" per the following safety standards:

For US, ANSI/ISA S82-1994

For Canada, CAN/CSA – C22.2 No. 1010.1-92

For Europe, EN610101-1

Conformity with these standards requires the user to provide adequate protection against a shock hazard. The user shall install this controller in an enclosure that limits OPERATOR access to the rear terminals.

▲ NOTICE

If the controller is used in a manner not specified by Honeywell, the protection provided by the equipment may be impaired.

Overall Dimensions

Figure 3-2 shows the overall dimensions for mounting the 7866 Controller.

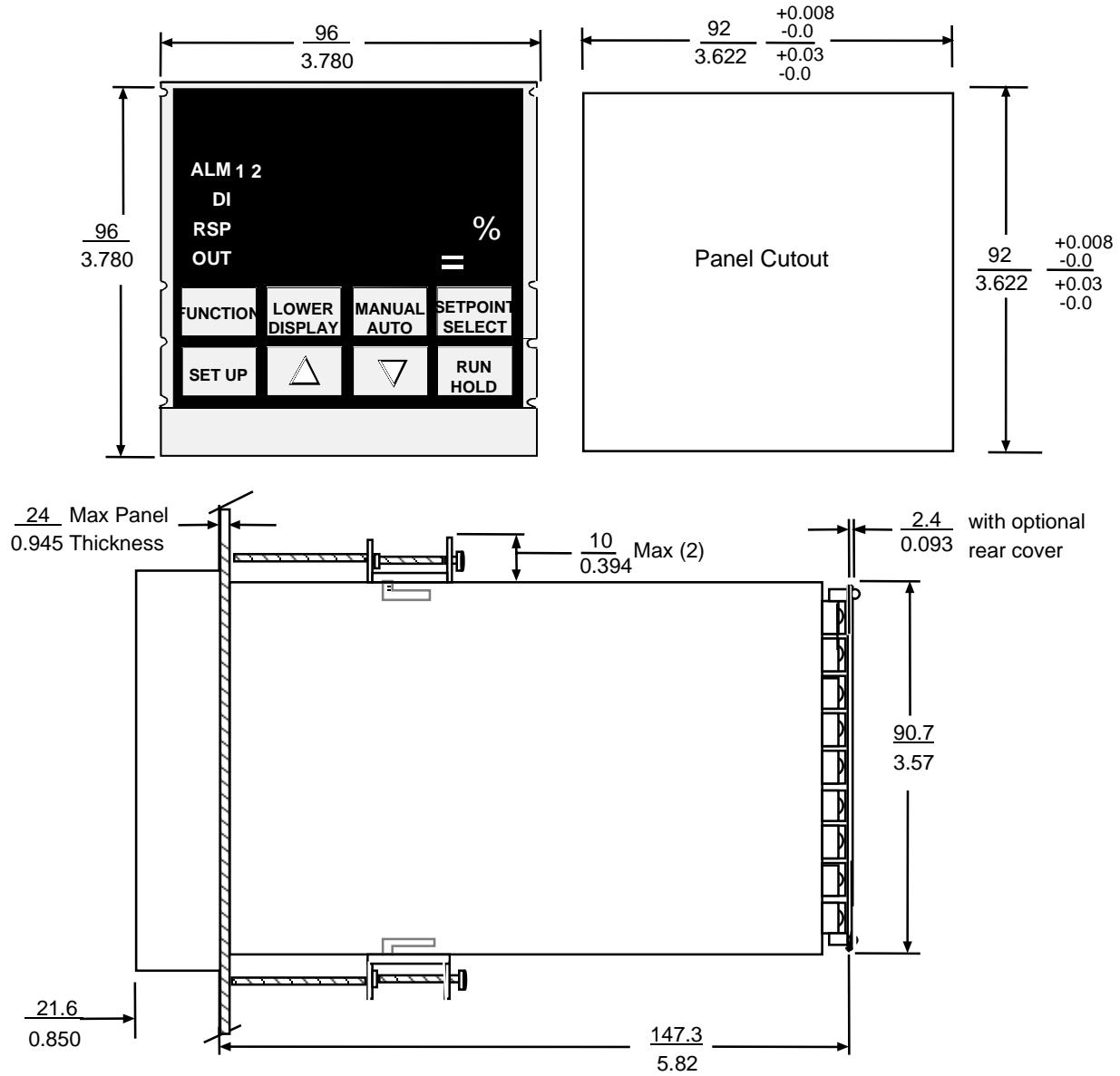

Figure 3-2 7866 Digital Controller Dimensions

Mounting Method

Figure 3-3 shows you the mounting method of the 7866 Controller.

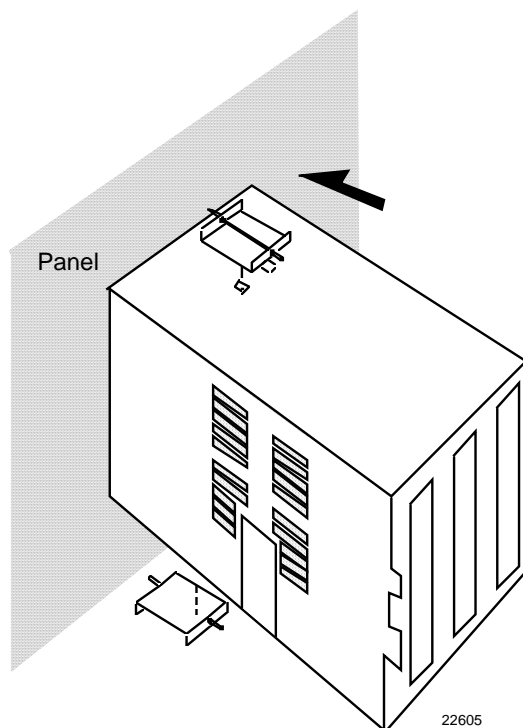

Figure 3-3 Mounting Method for Controller

Controller Mounting Procedure

Refer to Figure 3-3 and follow the procedure given below to mount the 7866 Controller.

Step	Action
1	Mark and cut out the controller hole in the panel according to the dimension information in Figure 3-2.
2	Remove the screw cover and loosen the screw on the front of the controller. Pull the chassis out of the case.
3	Orient the case properly and slide it through the panel hole from the front.
4	Remove the mounting kit from the shipping container, and install the kit as follows: <ul style="list-style-type: none"> • Install the screws into the threaded holes of the clips. • Insert the prongs of the clips into the two holes in the top and bottom of the case. • Tighten both screws to secure the case against the panel. • Carefully slide the chassis assembly into the case, press to close and tighten the screw. Replace the screw cover.

3.6 Wiring Between Sensing Unit and Digital Controller

Wiring Connections at the Sensing Unit

Step	Action
1	After the sensing unit is mounted, carefully remove the top housing by turning it counterclockwise. (Loosen the set screw.)
2	Two openings are provided for cable entrance; make certain the plug screw is tightened firmly into the unused right-hand opening.
3	Use 1/2 NPT threaded electrical conduit, and mount the special adapter fitting supplied with the analyzer.
4	Wire as shown in Figure 3-4.

WARNING

EXPLOSION-PROOF SENSING UNIT REQUIREMENTS

- Always use conduit for electrical wiring and follow special installation procedures.
- Make certain fully qualified personnel make this installation and all local regulations are observed.

Failure to comply with these instructions could result in fire caused by explosion inside the housing.

Wiring Connections at the Digital Controller

The output signal from the 7866 Digital Controller can be configured as a 4-20 milliampere signal or a 0-20 milliampere signal. This signal is used to drive a recording device or to report to a DCS or PLC. The signal will proportionately reflect the percentage of measured gas. Typically, the signal will be at minimum value, (0 mA or 4 mA) when the display reads Zero (“0.0”). The signal will be at 20 milliamperes when the display reads full-scale percentage. The signal is wired in series with a 250-ohm dropping resistor to produce a standard 0-5 volt or 1-5 volt input signal at the receiving device. The analog output can support a total resistive load of 800 ohms at maximum.

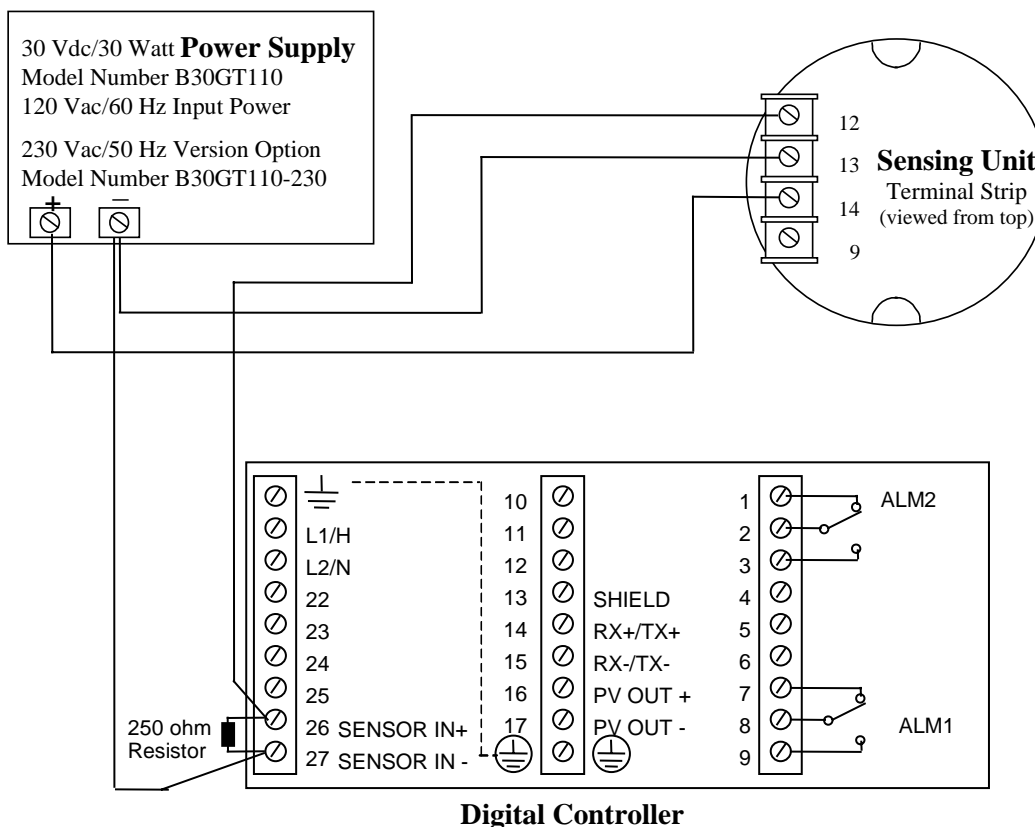

Figure 3-4 Interconnections Between Digital Controller and Sensing Unit

3.7 Checklist

Check #	Action
1	Check all wiring and piping. Make certain all fittings are tight. Replace the top bell housing on the sensing unit and tighten the set screw, if provided. No operating checks or settings are required in the sensing unit.
2	Shut off or vent the gas flow at the sampling system to make sure sample will not flow into the analyzer during start-up.
3	During calibration, it is necessary to read out the analyzer measurements. A milliammeter is used for verification of the readings. The meter should be wired in series with the signal wire between terminal 12 of the sensor and terminal 26 of the 7866 Digital Controller.

The test meter used, whether for voltage or current output, should be a digital voltmeter or a millivolt potentiometer for best accuracy. It should have an input impedance greater than 2000 ohms.

⚠ WARNING



- Do not open the bell housing of the sensing unit unless the power source is disconnected. Then loosen the set screw to permit housing cover to be turned.

Failure to comply with these instructions could result in death or serious injury.

4. Set Up Mode

4.1 Overview

This section describes the steps to configure the 7866 Controller for your application.

4.2 Configuration Tips

Introduction

Table 4-1 lists some tips that will help you enter data more quickly.

Table 4-1 Configuration Tips

Function	Tip
Displaying Groups	Use the SET UP key to display the Set Up groups.
Displaying Functions	Use the FUNCTION key to display the individual parameters under each group. The prompts are listed in the order they appear in each group.
Scrolling	<p>If the SET UP key is held in, the Group prompts scroll continuously at a rate of once every 2/3 of a second.</p> <p>Holding in either the ▲ or ▼ key will increase the scroll rate to once every 1/3 of a second in the forward or reverse direction while viewing Group prompts.</p>
Timing Out from Set Up Mode	If you are in Set Up mode and do not press any keys for 30 seconds, the controller will time out and revert to normal operation.
Key Error	<p>When a key is pressed and the prompt "KEY ERROR" appears in the lower display, it will be for one of the following reasons:</p> <ul style="list-style-type: none"> • Parameter is not available • Not in Set Up mode, press SET UP key first • Key not available for use in 7866 Controller

4.3 Unit Set Up Group

Function Prompts

Table 4-2 lists all the function prompts in the Unit Set Up group.

Table 4-2 Unit Group Function Prompts

Function Prompt (Lower Display)	Function Name	Selections or Range of Setting (Upper Display)	Factory Setting
SECURITY	Security Code	0000 to 9999	0
LOCKOUT	Configuration Lockout	NONE – Permits changes to all functions. CALIB – Calibration group functions are hidden from view. UNIT – Parameters in the Unit Set Up group cannot be changed, but the Alarms and Communications group parameters are changeable. (Calibration parameters cannot be seen.) VIEW – All parameters are read only. (Calibration parameters cannot be seen.)	NONE
TYPE	Analyzer Range Type	SINGLE – Read only	SINGLE
PC H2	<i>Sensor Input Types:</i> <i>Percent Hydrogen</i>	Factory-configured input type, as ordered. This parameter is Read only. The range chosen selects the range used for input, alarms, and outputs. The following is a list of possible input types. You will see only the one that was ordered. 0-1 0-2 0-5 0-10 0-15 0-20 0-30 0-75 0-100 50-100 80-100 85-100 90-100 95-100 98-100 60-80 40-80 45-55 20-50	Set as ordered

Function Prompt (Lower Display)	Function Name	Selections or Range of Setting (Upper Display)	Factory Setting
PC CO2	<i>Percent Carbon Dioxide</i>	0-10 0-15 0-20 0-30 0-40 0-100	
H2in AIR	<i>Hydrogen in Air</i>	0-100	
H2in CH4	<i>Hydrogen in Methane</i>	50-100	
HEin AIR	<i>Helium in Air</i>	70-100	
CH4in H2	<i>Methane in Hydrogen</i>	0-30	
CH4inAIR	<i>Methane in Air</i>	5-15	
O2in H2	<i>Oxygen in Hydrogen</i>	95-100	
H2in NH3	<i>Hydrogen in Ammonia</i>	0-75	
CUR OUT	PV Output Type Selection	4-20MA 0-20MA	4-20MA
PWR FREQ	Input Frequency Selection	60 HZ 50 HZ	60 HZ
DECIMAL	Decimal Point Location	XXX.X – One decimal place XX.XX – Two decimal places	XXX.X

4.4 Alarms Set Up Group

Function Prompts

Table 4-3 lists the function prompts in the Alarms Set Up group. Refer to Section 5.6 Setting the Alarm Limits for the alarm adjustment procedure.

Table 4-3 Alarms Group Function Prompts

Function Prompt (Lower Display)	Function Name	Selections or Range of Setting (Upper Display)	Factory Setting
ALARM1LO	Alarm 1 Setpoint, low alarm type	Value in percent Depends on the sensor input type selected. The setpoint range limit is set internally to that of the input type.	Lower limit of selected input range
ALARM2HI	Alarm 2 Setpoint, high alarm type	Value in percent Depends on the sensor input type selected. The setpoint range limit is set internally to that of the input type.	Upper limit of selected input range
HYSTERiS	Alarm Hysteresis	0 to 100.0	0.5

4.5 Modbus Communications Set Up Group

Introduction

This option allows the controller to be connected to a host computer via the Modbus protocol.

Function Prompts

Table 4-4 lists all the function prompts in the Modbus Communications Set Up group.

Table 4-4 Modbus Communications Group Function Prompts

Function Prompt (Lower Display)	Function Name	Selections or Range of Setting (Upper Display)	Factory Setting
Com ADDR	Communications Station Address	1 to 99 This is a number that is assigned to a controller that is to be used with the communications option.	1
BAUD	Baud Rate	19200 9600 4800 2400 This is the transmission speed in bits per second.	4800
WS FLOAT	Communications Message IEEE Byte Order	FP B – Floating point big endian (Bytes 0,1,2,3) FP BB – Floating point big endian with byte-swapped (Bytes 1,0,3,2) FP L – Floating point little endian (Bytes 3,2,1,0) FP LB – Floating point little endian with byte-swapped (Bytes 2,3,0,1)	FP B
DUPLEX	Duplex Operation	HALF – 2-wire communications FULL – 4-wire communications	HALF
TX DELAY	Transmission Delay	0 to 500 Delay time (in milliseconds) between receiving and sending messages.	0

4.6 Calibration Group

Calibration Data

Refer to *Section 5 Calibration* for complete calibration information and instructions.

4.7 Status Group

Status Test Data

Table 4-5 lists all the function prompts in the Status group. All prompts are read-only and provide the status of the background diagnostic tests.

Table 4-5 Status Group Function Prompts

Function Prompt (Lower Display)	Function Name	Read Only Displays (Upper Display)
VERSION	Software Version	7866_n The first number set (7866) details the unit class as the 7866 product and the next number set gives the software version.
RAM TEST	Status of RAM test performed in background	PASS or FAIL If status was FAIL, cycle power to see if error clears. If problem persists, the unit is bad and should be replaced.
CONFTEST	Status of Configuration Checksum test performed in background	PASS or FAIL If status was FAIL, completion of test results in re-computation of checksum and a new status of PASS. All configuration parameters should be rechecked for accuracy.
CAL TEST	Status of Working Calibration test performed in background	PASS or FAIL If status was FAIL, completion of test results in re-computation of CRC value. All calibration of inputs and outputs should be verified for accuracy.

5. Calibration

5.1 Overview

The 7866 analyzer is calibrated at the factory prior to shipping but it must be field-calibrated prior to operation. The input calibration procedure includes:

- setting zero for range 1,
- setting span for range 1,
- field-calibrating the current output(s),
- entering a security code,
- changing the security level, and
- setting alarm limits.

5.2 Sensing Unit Calibration

⚠ WARNING

- Do not open the bell housing of the sensing unit unless the power source is disconnected. Then loosen the set screw to permit housing cover to be turned.
- Before making any test with power applied to the sensing unit, either remove the sensing unit to a non-hazardous area or verify that the atmosphere is free from combustible gases.

Failure to comply with these instructions could result in death or serious injury.

5.3 7866 Input Calibration

Range 1: Span or Measured Gas as a Percentage of the Background Gas

Range 1 is used to indicate the percentage of span gas compared to the background gas. As the span gas is introduced, the display will progress from the low range limit to the upper range limit. The values of the display limits will vary based on the model number and selected application.

Table 5-1 Input Calibration for Range 1

Step	Press	Action
1		Connect the zero-calibration gas source to the sensor.
2	SET UP	until you see: <i>Upper Display:</i> CALIBR <i>Lower Display:</i> RANGE 1
3	FUNCTION	You will see: <i>Upper Display:</i> DISABL (default selection) <i>Lower Display:</i> RANGE 1
4	▲ or ▼	Select CALIB to begin manual calibration procedure for Range 1.
5	FUNCTION	You will see R1 ZERO in the Lower Display. The value shown in the Upper Display is a "live" reading. Wait until the value becomes stable.
6	FUNCTION	Captures the displayed value. The display will blink once indicating that you can use the ▲ and ▼ keys to change to the desired zero value. (This ties the internal counts processed for the input conversion to the desired value for Zero.)
7	FUNCTION	Saves Range 1 ZERO data. You will see R1 SPAN in the Lower Display. Connect the span-calibration gas source to the sensor. The value shown in the Upper Display is a "live" reading. Wait until the value becomes stable.
8	FUNCTION	Captures the displayed value. The display will blink once indicating that you can use the ▲ and ▼ keys to change to the desired span value. (This ties the internal counts processed for the input conversion to the desired value for Span.)
9	FUNCTION	Saves Range 1 SPAN data and processes the calibration calculations.

▲ NOTICE

If, after the Zero or Span "live" value has stabilized, no change is made, you should still perform the same key-press sequences. For example, if in Step 5 you make no change to the displayed value, continue to Step 7 by pressing the **FUNCTION** key twice.

Restoring Factory-set Input Calibration

A field calibration will overwrite any previous calibration values. However, the initial factory-set input calibration parameters can be restored, if desired, using the procedure in Table 5-2.

Table 5-2 Restoring Factory-set Input Calibration Values

Step	Press	Action
1	SET UP	until you see: <i>Upper Display:</i> CALIBR <i>Lower Display:</i> RANGE 1
2	FUNCTION	You will see: <i>Upper Display:</i> DISABL (default selection) <i>Lower Display:</i> RANGE 1
3	▲ or ▼	Select RESTOR to restore factory calibration for desired Range input parameters.
4	FUNCTION	Saves data to the factory-set values.

5.4 Output Calibration

Introduction

You can calibrate the controller so that the output provides the desired milliamper output when read through a meter connected to the desired output terminals.

NOTICE

Before doing an output calibration, make sure the PV Current Output Type (CUR OUT) selection in the Unit Set Up group (Table 4-2) is configured properly for either 4-20 mA or 0-20 mA. This selection must agree with what you are measuring for the output current to be calibrated correctly.

Table 5-3 Output Calibration Procedure

Step	Press	Action
1		Connect a milliammeter, with whatever accuracy is required, capable of measuring 0 to 20 milliamps, to terminals 16 and 17 for PV outputs.
2	SET UP	until you see: <i>Upper Display:</i> CALIBR <i>Lower Display:</i> CURRENT
3	FUNCTION	You will see ZERO VAL in the Lower Display. A four-digit value appears in the Upper Display. Use the ▲ and ▼ keys to change the value until the milliamper output, on the meter, is at the desired reading (4 mA or 0 mA).
5	FUNCTION	Saves the ZERO VAL data. You will see SPAN VAL in the Lower Display. A four-digit value appears in the Upper Display. Use the ▲ and ▼ keys to change the value until the milliamper output, on the meter, is at the desired reading (20 mA).
6	FUNCTION	Saves the SPAN VAL data and terminates the calibration procedure.

A field calibration will overwrite the manufacturing values. You cannot restore the factory-set output calibration.

5.5 Security Lockout

Introduction

The LOCKOUT feature in the 7866 Controller inhibits changes to certain functions or parameters by unauthorized personnel. There are three different lockout levels:

- NONE Allows changes to all functions and parameters.
- CALIB Calibration group functions are hidden from view.
- UNIT Parameters in Unit group cannot be changed.
- VIEW All parameter values are read only and calibration is not permitted.

Entering a Security Code

The level of keyboard lockout may be changed in the Set Up mode. However, knowledge of a four-character security code number [0000 (no security) to 9999] may be required to change from one level of lockout to another. When a controller leaves the factory it has a security code of 0, which permits changing from one lockout level to another without entering any other code number.

If you require the use of a security code, select a number from 0001 to 9999 and enter it when the lockout level is configured as NONE. Thereafter, you will need that selected number to change the lockout level from something other than NONE.

Table 5-4 Entering the Security Code

Step	Press	Action
1	SET UP	until you see: <i>Upper Display:</i> SETUP <i>Lower Display:</i> UNIT
2	FUNCTION	You will see SECURITY in the Lower Display.
3	▲ or ▼	Enter a four-digit number in the upper display (0001 to 9999). This will be your security code.
4	FUNCTION	Saves the security code to nonvolatile memory.

Changing Security Level

If the LOCKOUT feature has been set to anything other than NONE and a security code has been entered, you will have to change the LOCKOUT level to NONE before calibrating.

Table 5-5 Changing Security Level

Step	Press	Action
1	SET UP	until you see: <i>Upper Display:</i> SETUP <i>Lower Display:</i> UNIT
2	FUNCTION	You will see SECURITY in the Lower Display.
3	▲ or ▼	to enter the four-digit security code number (0001 to 9999) If the security code is unknown, see <i>Appendix A – Security Bypass</i> .
4	FUNCTION	You will see LOCKOUT in the Lower Display.
5	▲ or ▼	Select NONE .
6	FUNCTION	Saves selection to nonvolatile memory.

5.6 Setting the Alarm Limits

Each 7866 Digital Controller can be supplied with two alarms and two alarm relay outputs as a standard. (Second alarm is mutually exclusive with 4-20 mA ranging output.) The alarms monitor the displayed value of the measured gas. The alarms are preset to the low range limit and the high range limit of the sensor-input type selected. Refer to the procedure in Table 5-6 for changing the trip point values of each alarm.

Alarms are indicated on the left side of the display. When an Alarm is “in force,” a number “1” or “2” will be visible.

Alarm 1

When the measured gas percentage falls below this limit, Alarm 1 will engage. The default setting is equal to the low range limit. The alarm setpoint can be adjusted to suit the process requirement. When the alarm trips the normally open relay will de-energize and the relay contact will close. This relay contact can be used to interlock the system with the main process controller or wired to an alarm bell or flasher.

NOTICE

See wiring diagram in Section 3.6 for more detail on Alarm 1 terminals (Figure 3-4).

A deadband, also called “hysteresis”, will prevent clearing of the alarm until the measured gas is above the setpoint by 0.5 percent.

Alarm 2

(mutually exclusive with 4-20 ranging output)

When installed, the second alarm will trip when the displayed process value exceeds the alarm limit. The default setting for Alarm 2 is equal to the high limit of the range. The alarm can be adjusted to suit the process requirements. The relay contact that is linked with this alarm can be wired to an alarm annunciating horn, flasher, and/or shutdown safety system.

NOTICE

See wiring diagram in Section 3.6 for more detail on Alarm2 terminals (Figure 3-4).

Alarm 2 will activate when the measured percentage of gas exceeds the setpoint. A deadband, also called “hysteresis”, will prevent clearing of the alarm until the measured gas is below the setpoint by 0.5 percent.

Adjustment of the Alarm Limits

A four-digit security code may be required to adjust the Alarm Limits. If the code is unknown, consult your designated plant technician for the code. If you have forgotten the code, **see the Appendix B for the Security Bypass Procedure.**

Alarm Limits may be adjusted while the 7866 Digital Controller is operating. Care should be taken to minimize the effects of entering out-of-range values.

Table 5-6 Alarm Adjustment Procedure

Step	Press	Action
1	SET UP	until you see: <i>Upper Display:</i> SETUP <i>Lower Display:</i> ALARMS
2	FUNCTION	You will see ALARM1LO in the Lower Display. This is the Alarm 1 setpoint, low alarm type.
3	▲ or ▼	Enter low limit value. (Default = low range limit of selected input type)
4	FUNCTION	You will see ALARM2HI in the Lower Display. This is the Alarm 2 setpoint, high alarm type
5	▲ or ▼	Enter high limit value. (Default = high range limit of selected input type)
6	FUNCTION	You will see HYSTERIS in the Lower Display. This is the Alarm Hysteresis which sets the deactivation range for both alarms.
7	▲ or ▼	Enter hysteresis value between 0 % to 100.0 %. (Default = 0.5 %)
8	FUNCTION	Saves selections to nonvolatile memory.

▲ WARNING



The 7866 should be supplemented with additional safety systems where possible and appropriate. Pressure loss detectors and redundant gas loss detectors are recommended in critical applications. The user always assumes the responsibility of the correctness of the safety system design. It is always recommended that the installer, designer, and user consult with their insurance company, local authorities, and industry guidelines on such matters.

Failure to comply with these instructions could result in death or serious injury.

6. Operation

6.1 Overview

This section describes operating guidelines and procedures for the 7866 Digital Controller.

6.2 Operating Notes

The range reading is displayed in the upper display of the 7866 digital controller. In the lower display you can toggle (by pressing the LOWER DISPLAY key) between RANGE 1 and the input type.

6.3 Operation

The digital display will indicate measured value to the limit of the design range. If the signal from the sensor is outside the range, the display value will flash a range error message. In extreme cases, a recalibration may be required. However, normal variations due to changing gas flow rates and environmental factors may cause signal drift.

The alarm relays are normally energized when no alarm condition exists; therefore, the contacts will go to their alarm position upon loss of line voltage to the controller. Alarm limits can be set by pressing the SET UP key to enter the Set Up mode. The Alarms Set Up group can then be entered to adjust the setpoints of Alarm 1 and Alarm 2.

Two alarms can be available, each one with its own separate relay contact. When power is OFF, the relays are de-energized and their normally open contacts are non-conducting (open). When the alarms are operating, but there is no violation of the limits, the relays are energized and the relays' normally open contacts are conducting (closed). When an alarm limit is violated the specific relay will de-energize and create an open circuit. The open circuit can be used to activate an external device.

Alarm 1 is a LOW Alarm type. Alarm 1 will trip and remain on whenever the measured percentage goes below the entered value. Since applications vary, care should be taken to determine proper limits of operation. Consult your safety engineer or insurance company for proper operating parameters.

Alarm 2 is a HIGH Alarm type. This alarm will activate when the process value goes above the trip point or alarm limit. Consult your safety engineer or insurance company for proper operating parameters.

To adjust Alarm Limit 1 or 2, refer to *Section 5.6 Setting the Alarm Limits*. The Alarm range limits are consistent with the range of the PV Input.

Check calibration with zero and span gases about once each week. Always allow enough time (possibly several minutes) for a stable response. If the reading at the output device is not correct, adjust zero and span, using zero and span gases, in accordance with the procedures as described in *Section 5.3 7866 Input Calibration*. If only a slight zero-gas error exists, it can be corrected without rechecking the span gas. However, this must be considered a temporary correction and the calibration must be readjusted using both zero and span gas before another adjustment is made.

7. Maintenance

7.1 Routine Maintenance

The only routine maintenance required is the periodic checking and replacement of the calibrating and reference-gas cylinders. Note the supply pressure of flowing reference gas (if used), to avoid interruption of continuous gas analysis if the supply becomes exhausted. Check the sampling system flow rate daily to make certain that no blockage or buildup of particulates has occurred.

7.2 Parts Replacement

7.2.1 Sensing Unit



IMPROPER SENSING UNIT DISASSEMBLY

- Never open the 7866 Sensing Unit case until the line power has been disconnected at the 7866 Digital Controller.
- Always loosen the set screw provided on this model before turning the top bell housing.

Failure to comply with these instructions could result in death or serious injury.

To remove the housing cover, turn it counterclockwise and lift it off to expose all terminal board connections.

To remove the sensor assembly from its housing, first remove all connections at the terminal board and loosen the two screws (captive) in the cutouts at either side of the round circuit board. Carefully pull up on the handle as shown in Figure 1-2 to withdraw the entire unit.

Circuit Card

First remove the sensor assembly as described above. Then loosen the two captive screws on the underside of the plastic platform to free the entire circuit-card assembly. Carefully unsolder the 12 leads connecting the circuit card and cell assembly. The solder posts to which each lead is connected are identified in Table 7-1 by the wire-color code and the letters adjacent to each post. Note that two of the leads go to the jumper posts (S and T) on the platform.*

** If the circuit card is replaced, note that the standard R18 for most standard ranges is 1.5 K ohms and the new card may require the R18 resistor taken from the old card depending upon the range.*

Cell-Block Assembly

Remove the circuit card as described above. It is necessary to unsolder the interconnecting wires. Remove the two screws in the top platform and carefully separate the parts, sliding the platform along the wires. Remove the two screws in the large plastic sleeve and carefully slide this along the wires.

This provides access to the top of the block, allowing removal of heaters and thermistors. Identify the leads before unsoldering them from the bottom of the circuit card. See Table 7-1.

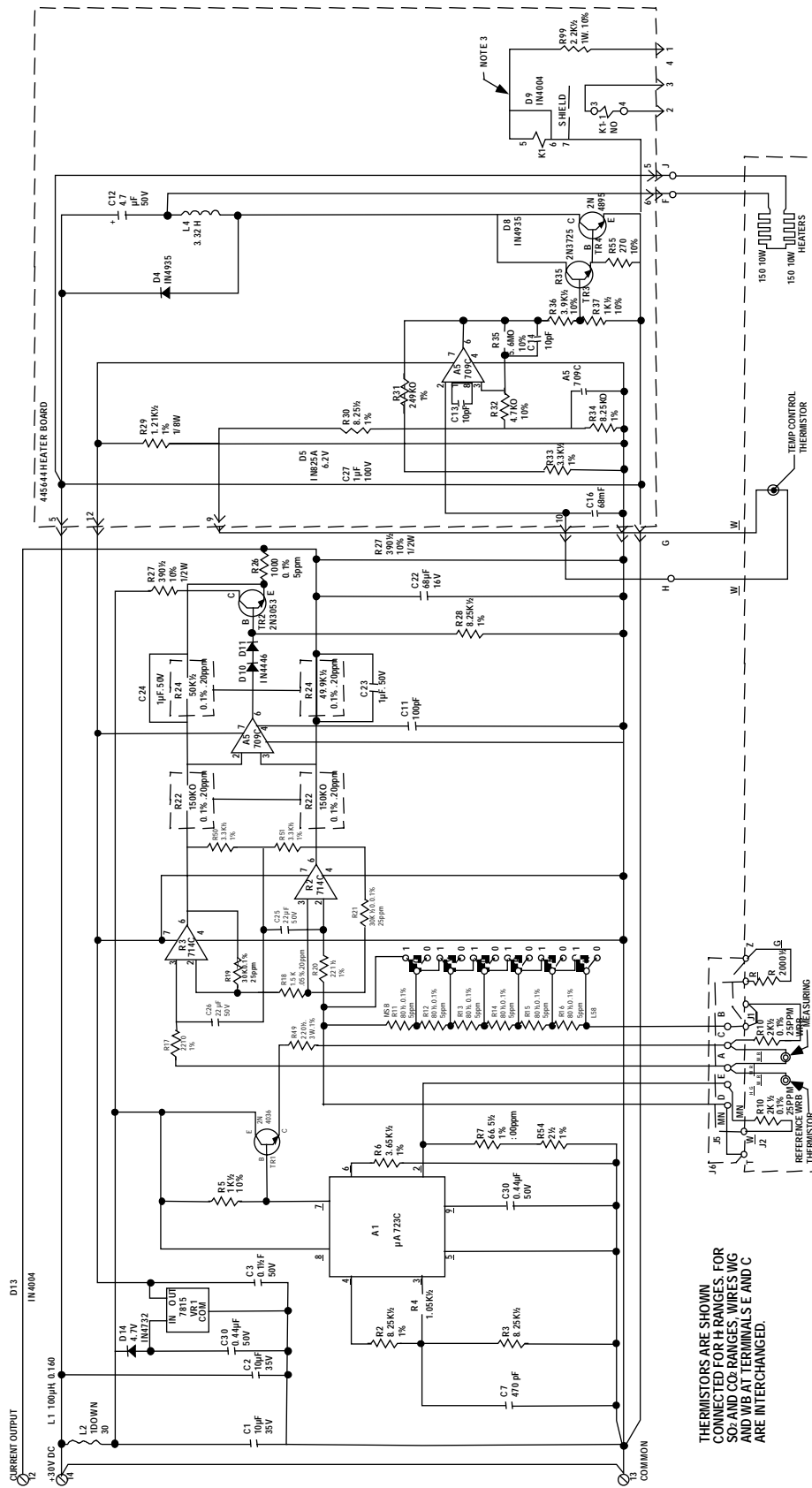

Figure 7-1 Sensing Unit Mother and Daughter Circuit Cards Parts List

Measuring and Reference Transistors

These thermistors are the two larger hex-head assemblies mounted in the top of the thermistor-chamber assembly. Leadwires plug onto terminal pins on each hex-head. Unscrew the entire assembly using appropriate care as the thermistors are mounted in small glass knobs at the end of each of these screw-in plugs. (Thermistors can be cleaned with solvent or detergent, rinsed, and dried.) The two thermistor plug assemblies are identical. The cell chambers are identified M for measure and R for reference. If new thermistors are to be installed, replace both seals because leakage between the Measuring and Reference Cell chambers will cause drift of the cell assembly output.

Table 7-1 Sensing Unit Cell Assembly Cable Connections

Circuit-Card Post	Wire	Cell-Block Circuit	Circuit-Card Post	Wire	Cell-Block Circuit
A	(2) Green/red		F	White/black	Heater
B	(1) Blue/red from S		J	White/black	Heater
C	(1) Blue/green		G	White	Thermistor
C	(1) White/blue/red	Bridge	H	White	Thermistor
D	(1) White/brown from T				
E	(1) Green/light green	Circuit			
E	(1) White/brown				

Temperature-Sensing Thermistors

These thermistors are the small hex-head assemblies. The leads are permanently attached. Unscrew the assembly and remove from the cell block. Coat the threads with silicone grease before reinstalling to insure a good thermal contact. Replacements are complete units, including leadwire.

Cartridge Heaters in Cell Block

Use a large screwdriver to remove the screw-in retainer, then remove the heater. Replace a pair of heaters rather than a single heater. Be especially careful not to damage the leads or insulation.

O-Rings at Inlet and Outlet Connectors (Figure 7-2)

Unscrew each fitting at the bottom of the cell block. The O-ring can now be removed from the cell-block. To remove the internal O-ring from the inlet or outlet fitting the outer casting, use a socket wrench to remove the retaining nut inside the casting, then pull out the entire fitting assembly and remove the O-ring. The external compression-fitting O-ring can be removed easily without taking out the entire assembly.

To remove O-rings and flame-arrestor parts from explosion-proof housing proceed as follows: Use a socket wrench to remove the retaining nut inside the casting. Remove the fitting, the small inside O-ring from the flame-arrestor, and withdraw the flame-arrestor fitting. The large outside O-ring can be removed from the fitting and the three filter elements can be pushed through the flame arrestor body from outside the casting with a length of tubing.

7.3 Repacking

When repacking for shipment, seal the sensor assembly inlet and outlet ports with tape to prevent packing material from clogging these ports.

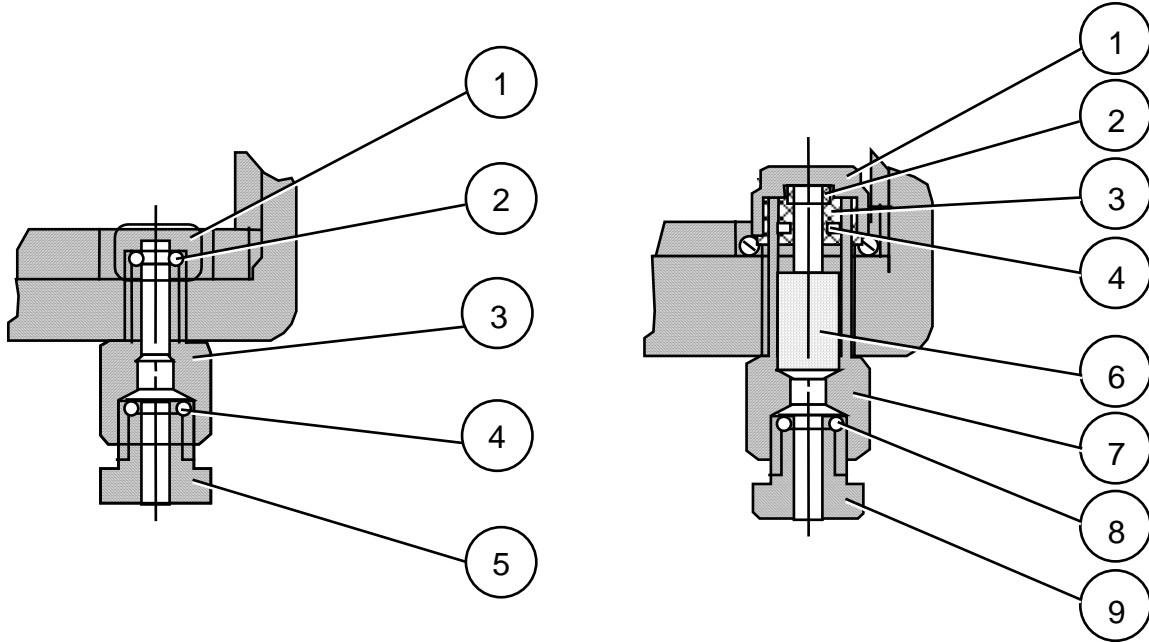

Figure 7-2 Gas Inlet and Outlet Fitting Parts

7.4 Spare Parts

To facilitate servicing and restore operation as quickly as possible in case of trouble, a stock of spare parts should be considered. If such a stock is desired, include the parts listed in Table 7-2.

Table 7-2 Recommended Spare Parts

Description	Part No.	Quantity
Sensor Assembly	See Model Selection Guide	1 for every 3 to 5 analyzers in use
Lower O-ring For Gas Fittings, Viton A For G = 3 and range -- Suffix D is 075, use Buna N	31005724 31082102	8 5
Middle O-ring For explosion-proof Gas Fittings, Viton A For G = 3 and range -- Suffix D is 075, use Buna N	082049 31075745	4 4
Filter Element for Explosion-proof Fittings	31085104	6
O-ring for Explosion-proof Housing Cap	31082103	1
Thermistor detectors (matched pair)	31130135	1
Plastic washer seals (for above detectors)	31301420	2
Resistor pair for Heater Assembly	31411258	1
Heater control Thermistor	31353402	2

8. Troubleshooting

8.1 Overview

This section describes various possible problems and the means to correct them.

8.2 Troubleshooting

8.2.1 General

If trouble is encountered in the adjustment of zero, refer to *Section 8.2.2 Recalibration* for adjustment procedures. If current flow in the sensing unit-7866 Digital Controller leads cannot be adjusted for 200 microamperes to 500 microamperes, refer to Step 2 in Table 8-4. Alarm circuit problems can usually be solved by referring to *Section 5.6 Setting the Alarm Limits*.

8.2.2 Recalibration

A routine procedure for checking calibration is presented in Table 8-1 Coarse Zero Adjustment.

WARNING



SENSING UNIT WITH EXPLOSION-PROOF DESIGN

- Never open the bell housing until the power line is disconnected at the 7866 Digital Controller.
- Always loosen the set screw before turning the bell housing.
- Never make any test with power applied to the sending unit until you either remove the sensing unit to a nonhazardous area or verify that the atmosphere is free from combustible gases.

Failure to comply with these instructions could result in death or serious injury.

Coarse Zero Adjustment (R11 and R16)

It may be necessary at some time to return the control-unit 20-turn fine ZERO (R16) to its center-of-travel position. To do so requires a jumper-wire change in the sensing unit.

Table 8-1 Coarse Zero Adjustment

Step	Action
1	Open the sensing unit and observe the jumper pattern used at the top of the round circuit card (terminal board at bottom). Note that each pin provided for the six jumpers is identified with a 1 or a 0. Determine the binary number formed by the jumper positions used and record this number. The letters identify the color of the corresponding jumper.
2	<p><i>If the analyzer output current or voltage is above zero or other low-end value and the ZERO adjuster is at its counterclockwise limit, determine that binary number which is one digit lower than the number recorded and change the necessary jumper positions to form this number. For example, if the jumpers are positioned to form binary number 111001, then the jumpers must be repositioned to form the next lower number binary 111000. Change the sixth jumper from 1 to 0.</i></p> <p><i>If the analyzer reading is below the low-end range value and the ZERO is at its clockwise limit, the zero must be shifted upscale. Position the jumpers to form the next higher number, e.g., from binary 011010 to 011011. Move the right-end jumper from 0 to 1.</i></p> <p>Refer Table 8-2 for the sequence used in binary counting. The card is screened with MSB (Most Significant Bit) and LSB (Least Significant Bit).</p>
3	The above jumper change should permit the return of fine ZERO adjuster R16 to its center-of-travel position and allow completion of the analyzer zero adjustment. If it does not, simply increase or decrease the binary number by one digit more. A change of one binary count is equivalent to one-half travel of control unit ZERO (R16). If jumpers are changed inadvertently before the binary number has been recorded (or if thermistor detectors have been replaced) re-establish the correct jumper pattern. Measure the sensing-unit current output by connecting a meter in series with terminal 12 at the sensing unit while zero-gas flows through the sensing unit. Proceed through the steps in Table 8-3 in numerical sequence only until the current output measures between 250 μ A and 240 μ A. Jumpers that have been placed in their final positions, not been moved, are marked X. Start with binary 32 (100000).

Table 8-2 Binary Count Sequence for Coarse Zero Jumper Pattern

MSB	LSB	MSB	LSB	MSB	LSB	MSB	LSB
0	000000	16	010000	32	100000	48	110000
1	000001	17	010001	33	100001	49	110001
2	000010	18	010010	34	100010	50	110010
3	000011	19	010011	35	100011	51	110011
4	000100	20	010100	36	100100	52	110100
5	000101	21	010101	37	100101	53	110101
6	000110	22	010110	38	100110	54	110110
7	000111	23	010111	39	100111	55	110111
8	001000	24	011000	40	101000	56	111000
9	001001	25	011001	41	101001	57	111001
10	001010	26	011010	42	101010	58	111010

MSB	LSB	MSB	LSB	MSB	LSB	MSB	LSB
11	001011	27	011011	43	101011	59	111011
12	001100	28	011100	44	101100	60	111100
13	001101	29	011101	45	101101	61	111101
14	001110	30	011110	46	101110	62	111110
15	001111	31	011111	47	101111	63	111111

Table 8-3 Coarse-Zero Jumper Pattern

Step	If current is	Jumper Positions					
		G	Y	O	R	N	K
1	above 450 μ A below 250 μ A	1	0	0	0	0	0
		0	1	0	0	0	0
		1	1	0	0	0	0
2	above 450 μ A below 250 μ A	X	0	1	0	0	0
		X	1	1	0	0	0
3	above 450 μ A below 250 μ A	X	X	0	1	0	0
		X	X	1	1	0	0
4	above 450 μ A below 250 μ A	X	X	X	0	1	0
		X	X	X	1	1	0
5	above 450 μ A below 250 μ A	X	X	X	X	0	1
		X	X	X	X	1	1

8.2.3 Fault Isolation Tests

The troubleshooting guide provided in Table 8-4 can be used in conjunction with the fault-isolation tests to identify and solve most analyzer problems. If the source of trouble is not apparent from the symptoms given in the table, then the following checks may be used to isolate the site of an unknown source of trouble to either the sensing unit or the 7866 Digital Controller. The troubleshooting table can be used to better identify the malfunction, either before or after these isolation tests are performed, according to the specific symptom. When the fault is thus generally located, replace the faulty circuit card with a spare and return the card to Honeywell for repair in order to quickly restore service.

The following is a list of test equipment required to perform all of the various tests and troubleshooting procedures described in this section:

- Simpson Model 260 Multimeter or equivalent 20,000 ohms-per-volt meter for voltage, current, and resistance measurements.
- Resistor 2500 ohms \pm 5 %
- Resistor 30 ohms, 25 watts
- Six-volt battery
- Adjustable resistor (up to 20 K ohms)
- Span gas mixture equal to full-scale reading

7866 Digital Controller Test

At the control-unit terminal board, disconnect the sensing-unit leads connected to terminals 12, 13, and 14, and connect a dummy load of 30 ohms, 25 watts across 13 and 14. Voltage measured across this load should be between 24 volts dc and 28 volts dc.

Use a six-volt battery, the current meter and an adjustable resistance (up to 20K ohms) in series across terminals 12 (+) and 13 (-). Connect (-) battery terminal to terminal 13. Pass about 350 uA between terminals 12 and 13. The control unit should display 0.0 % for Range 1. Refer to *Section 5* for the proper Calibration procedure, if necessary.

Leaving the above circuit connected, set the meter to its 20 mA range. Now adjust the current flow and observe the mA reading. The current flow required to obtain a 5-volt reading across terminals 12 and 13 must not exceed 20 mA. The control unit should display 100.0 % for Range 1. Refer to *Section 5* for the proper Calibration procedure, if necessary.

If either of these values are not achievable, then the controller’s analog input card is suspect. Before drawing that conclusion, check the obvious. Wiring and bad connections often are the cause.

Sensing Unit Test

Remove the upper housing. The entire cell assembly can be left in the lower housing or removed as desired. Connect the 26 Vdc to 32 Vdc power supply (1 ampere) to terminals 13 (-) and 14 (+) and wait one half hour for warm-up. Connect a current meter in series with 2500 ohms between terminals 12 (+) and 13 (-).

Pass the “zero” gas through the sensing unit at a rate of 500 to 1000 cc per minute. (Provide a reference gas flow if required.) The current reading on the test meter should be 200 uA to 500 uA. If not, adjust coarse zero jumpers per the Coarse Zero Adjustment (R11 and R16).

Remove the “zero” gas and pass a full-scale gas through the sensing unit at a rate of 500 to 1000 cc per minute and note the current reading on the test meter. The current must increase by at least 1 mA to 2 mA for the change from “zero” gas to full-scale “span” gas. The change may be as much as 20 mA depending on range.

If any of these conditions cannot be attained, probably the circuit card or the thermistors are defective.

Table 8-4 Troubleshooting Procedures

Symptom	Possible Cause	Recommended Checks
1. Blank Display	1a. No line voltage.	1a. Check for correct voltage at terminals L1/H and L2/N. 1b. Replace the display.
2. Cannot adjust for zero signal with “zero” gas.	2a. ZERO adjuster in 7866 Digital Controller is out of adjusting range. 2b. Open signal circuit. (Causes below-zero signal.) 2c. Detector unbalance is too large.	2a. Adjust coarse ZERO in sensing unit in accordance with the Coarse Zero Adjustment. 2b. Check interconnecting wiring between 7866 Digital Controller and sensing unit for continuity 2c. With “zero” gas flowing, connect a high-impedance voltmeter (on 5 V range) first between pins A and E, then between pins A and C. If $(VAE - VAC)/(VAE + VAC)$ is greater than ± 0.035 , replace or clean the pair of detectors in the cell block.

Symptom	Possible Cause	Recommended Checks
3. Insufficient span with "span" gas flowing and SPAN ADJUSTER fully clockwise.	<p>3a. Faulty current regulator for detector bridge.</p> <p>3b. Faulty sensing-unit amplifier.</p> <p>3c. Damaged measuring detector.</p>	<p>3a. Check for 3.75 volts \pm 0.4 volts between pin E and terminal 13. (This is equivalent to checking bridge current for 55 mA \pm 5 mA.)</p> <p>3b. Disconnect the lead at terminal 12 in the sensing unit and connect a 0-1 mA current meter across terminals 12 (+) and 13 (-). Refer to Table 8-2 and increase the coarse-zero binary count (on the coarse-zero jumper pattern described in the Coarse Zero Adjustment procedure) by one number. Current flow should increase about 250 μA. This verifies that gain is normal.*</p> <p>3c. Connect a millivolt meter across circuit points A and D (at center of round card). Make the zero adjustment in accordance with the recalibration procedure. Pass a span-gas mixture equivalent to a full-scale measurement through the sensing unit. The meter reading for 1 % H₂ should be at least 10 mV.** If it is less, the detectors must be cleaned or replaced.</p>
4. Slow response.	<p>4a. Low flow rate.</p> <p>4b. Sample lines too long; filter volumes too large, etc. for flow rate.</p> <p>4c. Measuring detector or cell block is dirty.</p>	<p>4a. Increase flow rate to 2000 cc/min. for maximum speed or response.</p> <p>4b. Increase flow rate above 2000 cc/min., venting excess flow above 2000 cc/min. with a by-pass valve upstream of the analyzer.</p> <p>4c. Remove detectors and check for flow between inlet and cell before remounting the detectors.</p>
5. Noisy output signal or electrical interference.	<p>5a. Lack of earth ground.</p> <p>5b. Power line not grounded correctly.</p> <p>5c. Flow rate too high.</p> <p>5d. Cracked or dirty measuring detector.</p> <p>5e. Faulty detector bridge-current regulator.</p>	<p>5a. Check that ground wire is connected to ground terminal and that controller case is connected to ground terminal.</p> <p>5b. Check that terminal L2/N is connected to the neutral or grounded side of power line. If one side of line is not grounded, install an isolation transformer and ground terminal L2/N.</p> <p>5c. Check that flow does not exceed 2000 cc/min.***</p> <p>5d. Remove measuring detector, inspect for cracks in glass or loose dirt in cell.</p> <p>5e. Replace sensing-unit printed circuit card assembly.****</p>

Symptom	Possible Cause	Recommended Checks
6. Output signal is unstable.	6a. Temperature control is inoperative.	6a. Check cell block for approximately 50 °C (122 °F) temperature (too hot to hold in the hand for very long). Check heaters for 30 ohms nominal resistance for series pair. Ambient temperature must not exceed 50 °C (122 °F).
	6b. Temperature control cycles.	6b. Check that temperature-sensing thermistor is screwed tightly into the cell block and that its tip and threads are coated with silicone grease. Connect a 0 to 1 amp meter in series with one of the heater leads. During warm-up, current should be approximately 800 mA. When 50 °C (122 °F) is reached current will decrease, cycling 2 or 3 times before current stabilizes at a lower value. If cycling continues, replace the sensing unit circuit-card assembly. ****
	6c. Sample flow rate or composition varies.	6c. Check stability when operating on zero gas. If stable, check for large sample flow variations, water vapor variations due to unstable drier or cooler operation, etc.
7. Alarm malfunction.	7a. Alarm set point adjustment is inaccurate.	7a. Adjust "Alarm 1" or "Alarm 2". (See Section 5.6.)
	7b. Relay contacts worn or damaged.	7b. Replace circuit board if required.
	7c. Relay fails to energize (alarm condition always indicated.)	7c. Check alarm limits. (See Section 5.6.)
	7d. Relay fails to de-energize (alarm condition never indicated.)	7d. Check alarm limits. (See Section 5.6.)

*For hydrogen spans greater than 10 %, current increase should be about 80 µA.

**For higher ranges, minimum reading is proportionately higher, e.g., for 0 % to 30 % H₂, reading should be 30 mV.

***On flowmeters calibrated for air, note that actual flow may exceed that indicated for H₂ or other gases.

****Temperature regulator is a high-frequency variable-duty cycle controller and field repair is not recommended. Replace the entire sensing-unit card and return the faulty unit to the factory for repairs.

8.2.4 Additional Troubleshooting

General

Verify that piping of analyzer and flow rates are correct. Verify that wiring of analyzer is correct.

Power Supply Fault

30 V supply — Measure voltage between sensor terminals 14 (hot) and 13 (common). It should read 30 +2, -6 volts. Actual value depends upon current drawn by heaters.

Temperature Control Inoperative

Heater voltage — Measure voltage between terminal given below (hot) and terminal 13 (common).

Terminal F. Warmed-up (at 50 °C); 19 ± 3 V. Cold start from (25 °C); 2.5 ± 0.5 V

Terminal J. Warmed-up (at 50 °C); 30 +2, -4 V. Cold start from (25 °C); 28 ± 3 V.

Heater thermistor voltage — Measure voltage between terminal given below (hot) and terminal 13 (common).

Terminal G. Warmed-up (at 50 °C); 6.2 ± 0.2 V. Cold start from (25 °C); 6.2 ± 0.2 V.

Terminal H. Warmed-up (at 50 °C); 3.1 ± 0.1 V. Cold start from (25 °C); 1.5 ± 0.5 V.

Zero and Span Check — measure current at Terminal 12

Zero Gas – Sensor output current to be between 250 μ A and 450 μ A.

Span Gas – Sensor output current to be approximately 12-18 mA at full range depending on gas type.

Resistance Check (Sensor Card Disconnected)

R8 = 2078 ohms \pm 0.1 %

R10 = 2000 ohms \pm 0.1 %

Temperature Control Thermistors

50 °C, 122 °F, R= 3.6 K ohms \pm 5 %

25 °C, 77 °F, R = 10 K ohms \pm 5 %

Heaters, R = 30 ± 3 ohms (one pair)

Measuring Cell (WR to WB wires)

50 °C, 122 °F, R = 2024 ohms \pm 20 %

25 °C, 77 °F, R = 5000 ohms \pm 20 %

Reference Cell (WR to WG wires)

50 °C, 122 °F, R = 2024 ohms \pm 20 %

25 °C, 77 °F, R = 5000 ohms \pm 20 %

NOTICE

Measuring and reference cells resistances should be matched to 1 %.

Test for short circuit between leads of each of the above components and case ground.

9. Appendix A – Security Bypass

9.1 Overview

Your controller has a security bypass code. Secured areas cannot be accessed without the use of the Operator or Master codes. If you have forgotten or misplaced the access code, you can enter the factory default code, “7866”. Use the procedure given in Table 5-4 to enter 7866 to override the forgotten code.

Honeywell

Sensing and Control
Honeywell
11 West Spring Street
Freeport, IL 61032