

---

## Model HDT

### Loop-powered Hybrid Dewpoint Transmitter



**-100°C(dp) to +20°C(dp)**

- HTF™ Aluminum Oxide Sensor Technology
- Loop-powered
- Analog (4-20 mA) Output
- Digital (HART Compliant) Output
- Programmable Alarm Signal
- NEMA 4X IP66 Enclosure
- Compact Design
- Temperature Compensated Calibration



# HDT Hybrid Dewpoint Transmitter

## HTF™ High Capacitance Aluminum Oxide Sensor

The HDT uses a COSA HTF™ high capacitance aluminum oxide sensor with a measuring range of -100°C(dp) to +20°C(dp). HTF™ sensors provide a degree of accuracy, speed of response and stability unavailable from instruments using conventional sensors.

## Hart-compliant, IP66/NEMA4X Transmitter

The model HDT is a Hart compliant IP66/NEMA4X hybrid dewpoint transmitter, providing loop powered analog as well as a digital output. Housed in a 1.25" dia. stainless steel case it has an overall length of 5.68", including the standard industrial 9.4mm 4 pin connector. This makes the HDT the world's smallest dewpoint transmitter.

## Analog Output Loop

The instrument draws 4-20mA from the power supply. The 4-20mA is linear to °C(dp) with an output resolution of 0.1°C(dp) or 0.25uA, whichever is greater. The output range is programmable.

## Digital Output Loop

The instrument can supply a digital output by modulating the 4-20mA loop line. The interface is defined by HART. In the digital mode the HDT can be remotely operated and the

dewpoint as well as temperature (and pressure if installed) can be read. In the digital mode multiple units can operate on the same loop cable as a multi-channel instrument. In this configuration each HDT draws only 4mA independent of the measured dewpoint

## Built-in Alarm

The HDT provides a factory programmable dewpoint alarm signal through a digital output pin. Additionally, relays or external devices can be operated through the analog or digital loops.

## Connections

The HDT has two different thread types, which makes the upgrade of existing installations easy. The HDT connects through inexpensive two-conductor cables over long distances.

## Measurement Accuracy/Stability

The HDT transmitter uses a multipoint calibration table which provides temperature compensated dewpoint readings for temperatures from -10°C(t) to +70°C(t). Thus, the HDT provides accurate dewpoint measurements over its full range even under extreme temperature conditions, such as when installed outdoors or close to heat sources.

## COSA HTF™ Aluminum Oxide Technology

Due to a hyper-thin film and a unique pore geometry, COSA sensors have a capacitance change over their full range, several orders of magnitude larger than that of conventional aluminum oxide sensors. Additionally, this change is quasi linear and its sensitivity to temperature is negligible.

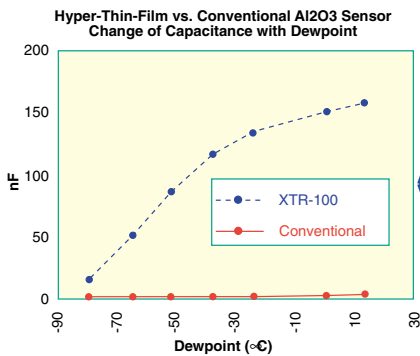

The advantages of the linear high capacitance response of COSA HTF™ sensors are shown in the graphs below:

**Negligible Ageing Drift**

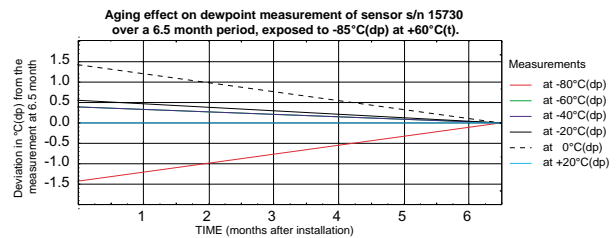

**Better Temperature Coefficient**

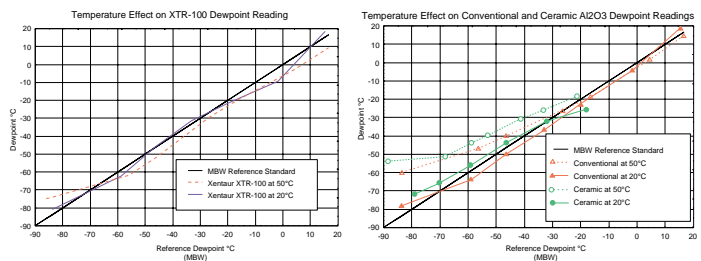

**Faster Response**

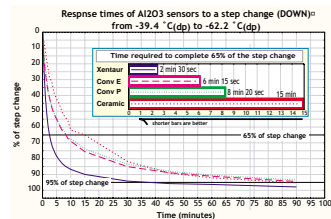

For more detailed technical information, please visit our web site at:

[www.xentaur.com](http://www.xentaur.com)

## Specifications of HDT Transmitter

The HDT is a loop powered HART enabled dewpoint transmitter.

Enclosure: . . . . . Stainless Steel, IP66 NEMA 4X.

Dimensions & Weight: . . . . . ~1.25" Dia. x ~5.68" long including sensor & connector; 0.5lbs.

Pressure operating range: . . . . . Standard: 500 PSI (34 bar).  
Optional: 5,000 PSI (340 bar).

Operating Temperature: . . . . . -10°C to +70°C.

Mechanical connection: . . . . . 14mm x 1.25mm threads, and 3/4"-16 threads.

Electrical connections: . . . . . Industrial Standard 9.4 mm, 4 pin connector. IP66 NEMA 4X

Cable: . . . . . Two conductor cable. Min. #24AWG; for total cable length >5000ft.: min. #20AWG

Power Requirements: . . . . . 5 to 28 VDC, the instrument draws 4-20mA depending on measured dewpoint.

Input resolution: . . . . . 0.1°C dewpoint.

Indicators: . . . . . None.

Engineering units: . . . . . °C(dp), °C(t).

Controls: . . . . . HART interface, user's selections are stored in EEPROM.

Outputs: . . . . . Analog and digital outputs are available.

A. 4-20mA drawn by the instrument from the power supply. The 4-20mA is linear to °C, the range is programmable. Output resolution is 0.1°C dewpoint or ~ 0.25uA whichever is greater.

B. The instrument can supply digital output by modulating the 4-20mA loop line. The interface is defined by HART. In the digital mode the HDT can be remotely operated and the dewpoint as well as temperature (and pressure if installed) can be read. In the digital mode multiple units can operate on the same loop cable as a multi-channel instrument. In this configuration each HDT draws only 4mA independent of the measured dewpoint

Alarms: . . . . . The 4-20mA signal may be used by an external device to operate relays. In addition a digital output pin is provided which can be factory (or specially equipped customer) programmed to provide dewpoint alarm indications.

Isolation: . . . . . Sensor and case are grounded to the current loop negative side.

Warranty: . . . . . 1 year

## Specifications of HTF™ Dewpoint Sensor Element

Type . . . . . Hyper Thin Film high capacitance Al<sub>2</sub>O<sub>3</sub>

Dewpoint range:

XTR-100: . . . . . -148°F to +68°F (-100°C to +20°C)

XTR-65 . . . . . -85°F to +68°F (-65°C to +20°C)

Capacitance: . . . . . 15nF to 200nF

Accuracy: . . . . . ±5.5°F (±3°C)

Repeatability: . . . . . ±0.9°F(±0.5°C)

Temperature Range: . . . . . -14°F to 158°F (-10°C to +70°C)

Sample flow range:

(linear vel. @ 1atm): . . . . . Static to 100 m/s

Storage temperature: . . . . . -40°F to +176°F (-40°C to +80°C)

Calibration method: . . . . . Multipoint calibration table with temperature compensation over the full range

## Dimensions:

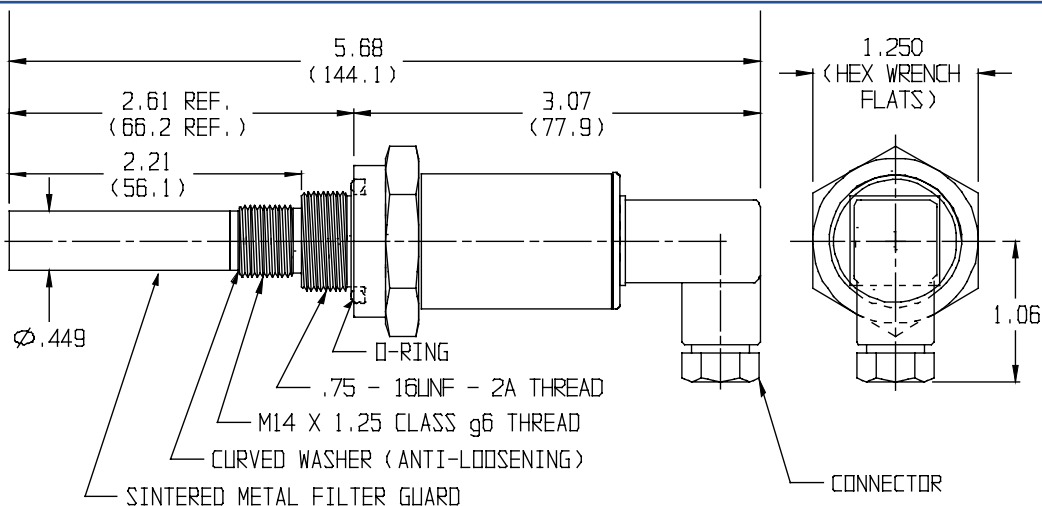

# Methods of using and interfacing the HDT Transmitter:

## HDT Block Diagram

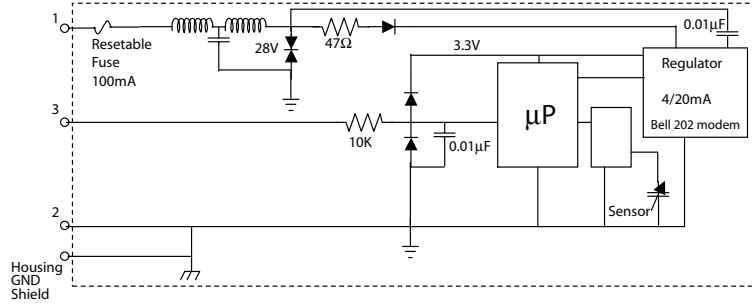

## Standard hookup

Monitor current (4/20mA) across resistor R, and/or HART signal across pins 1&2. Choose V and R such that there is a minimum of 6V across pins 1&2 when the instrument draws 20mA, and no more than 28V when the instrument draws 4mA. For standard HART connections recommended  $250 < R < 500$  ohms.

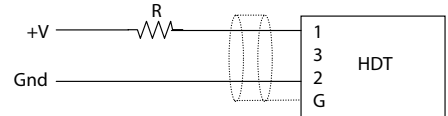

## Economy hookup

Monitor digital RS-232 TTL level.

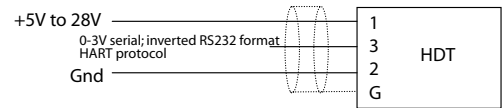

## Factory preset alarm hookup

Monitor and/or drive relay from digital level alarm. Special order means that factory default settings must be modified, and alarm level must be chosen.

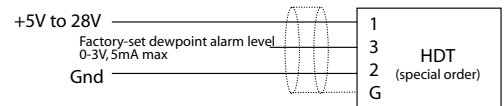

## Low Voltage receive only HART hookup.

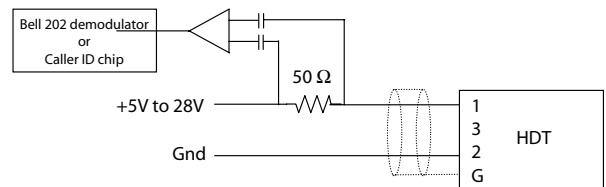

## Multi-channel hookup

Multiple HDT transmitter are parallel connected through an interface box to the serial port of a PC. In this mode, each transmitter draws 4 mA regardless of dewpoint.

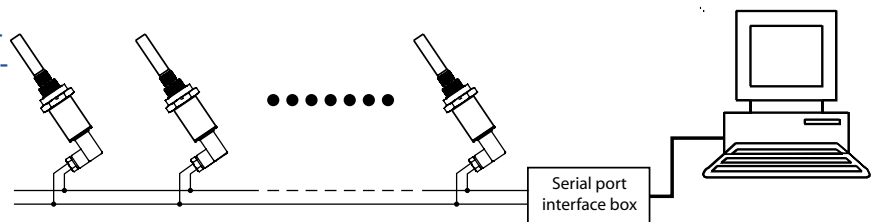

Exclusive US Distributor:



COSA INSTRUMENT CORPORATION

55 Oak Street, Norwood, NJ 07648  
Tel: (201) 767-6600 Fax: (201) 767-6804

7125 North Loop East, Houston, TX 77028  
Tel.: (713) 947-9591 Fax.: (713) 947-7549

e-mail: [cosa@cosaic.com](mailto:cosa@cosaic.com) [www.cosa-instrument.com](http://www.cosa-instrument.com)