

	Prices Start at	See Page
Infrared Temperature Measurement		
Ametek Land Digital Industrial Infrared Thermometers	Call	117
Ametek Land Infrared Process Imaging and Scanning Systems	Call	119
Ametek Land Control and Analysis Software	Call	121
Resistance Temperature Detectors (RTDs)		
Pyromation 3A Sanitary RTDs for the Food Industry	\$130.00	100
Pyromation RTDs for General Service	\$78.70	98
Pyromation RTDs with Threaded Thermowells	\$127.00	99
Temperature Transmitters		
Honeywell STT170 Programmable Temperature Transmitters	\$130.00	111
Honeywell STT250 Smart Temperature Transmitter	\$569.00	112
Honeywell STT350 Smart Temperature Transmitter with Digital Display	\$1065.00	113
Pyragon TouchTemp II Programmable Temperature Transmitter	\$490.00	116
Pyromation Transmitter Assemblies for Field-Mount RTDs	\$110.00	112
Siemens SITRANS T Head Mount Temperature Transmitters	\$113.05	114
Siemens SITRANS TF Field Mount Temperature Transmitters	\$885.16	116
Thermocouples		
Pyromation Industrial Thermocouples with Termination Heads	\$72.70	102
Pyromation Metal Protection Tube Thermocouple Assemblies	\$75.00	104
Pyromation Thermocouple Assemblies for General Service	\$43.20	101
Pyromation Thermocouple Assemblies with Quick-Disconnect Plugs	\$23.20	102
Pyromation Thermocouples with Matching Thermowells	\$78.00	103
WIKA/Gayesco Multipoint Temperature Sensors	Call	109
WIKA/Gayesco Tubeskin Temperature Sensors for Process Furnaces	Call	106
Parts and Accessories		
DIN-Rail Mountable DC Power Supplies	\$60.00	122
Pyromation Plugs and Jacks	\$4.10	105
Pyromation Thermocouple Accessories	Call	104
Pyromation Thermocouple Wire and Sensor Extension Wire	Call	105
United Electric Sensor Box	\$650.00	122
WIKA/Gayesco Services for Tubeskin Sensor Installations	Call	108

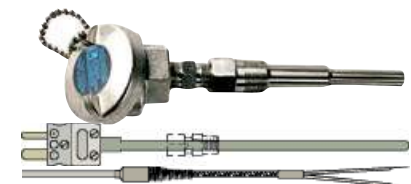

Level Measurement Instruments

Flow Measurement Instruments

Pressure Transmitter

Temperature Sensors and Transmitters

Wireless Sensing and Communications

Analytical Instruments and Systems

RTDs Resistance Temperature Detectors for General Service

Features

- Available in any length
- 316 stainless steel sheath
- 3-wire DIN standard 0.00385Ω temperature coefficient
- 2 accuracies: ±0.1% and ±0.01%
- For temperatures from -328° to 400° F
- Transition fitting with spring relief good to over 400° F
- Works with compression fittings



Model Selection Guide — Assemblies with Leads

Sheath		Accuracy	Catalog Number for 12" Sheath Length	Price Each	Price Adder per 6" Sheath Length
Material	Diameter				
100Ω RTD Assemblies with 36" Leads					
316 SS	1/8"	±0.1%	R1T185L283-012-00-15-T3036-2	\$78.70	\$7.00
316 SS	3/16"	±0.1%	R1T185L383-012-00-15-T3036-2	78.70	7.00
316 SS	1/4"	±0.1%	R1T185L483-012-00-15-T3036-2	78.70	7.00
316 SS	3/8"	±0.1%	R1T185L683-012-00-15-T3036-2	78.70	7.00
316 SS	1/8"	±0.01%	R5T185L283-012-00-15-T3036-2	110.70	7.00
316 SS	3/16"	±0.01%	R5T185L383-012-00-15-T3036-2	110.70	7.00
316 SS	1/4"	±0.01%	R5T185L483-012-00-15-T3036-2	110.70	7.00
316 SS	3/8"	±0.01%	R5T185L683-012-00-15-T3036-2	110.70	7.00



Model Selection Guide — Assemblies with Quick-Disconnect Plugs

Sheath		Accuracy	Catalog Number for 12" Sheath Length	Price Each	Price Adder per 6" Sheath Length
Material	Diameter				
100Ω RTD Assemblies with Quick-Disconnect Plugs					
316 SS	1/8"	±0.1%	R1T185L283-012-00-4MC	\$91.70	\$7.00
316 SS	3/16"	±0.1%	R1T185L383-012-00-4MC	91.70	7.00
316 SS	1/4"	±0.1%	R1T185L483-012-00-4MC	91.70	7.00
316 SS	3/8"	±0.1%	R1T185L683-012-00-4MC	91.70	7.00
316 SS	1/8"	±0.01%	R5T185L283-012-00-4MC	123.70	7.00
316 SS	3/16"	±0.01%	R5T185L383-012-00-4MC	123.70	7.00
316 SS	1/4"	±0.01%	R5T185L483-012-00-4MC	123.70	7.00
316 SS	3/8"	±0.01%	R5T185L683-012-00-4MC	123.70	7.00

Model Selection Guide — Assemblies with Termination Heads

Sheath		Accuracy	Catalog Number for 12" Sheath Length	Price Each	Price Adder per 6" Sheath Length
Material	Diameter				
100Ω RTD Assemblies with Aluminum Termination Heads (See Below for Optional Heads)					
316 SS	1/8"	±0.1%	R1T185L283-012-00-8HN31	\$123.00	\$7.00
316 SS	3/16"	±0.1%	R1T185L383-012-00-8HN31	123.00	7.00
316 SS	1/4"	±0.1%	R1T185L483-012-00-8HN31	123.00	7.00
316 SS	3/8"	±0.1%	R1T185L683-012-00-8HN31	123.00	7.00
316 SS	1/8"	±0.01%	R5T185L283-012-00-8HN31	155.00	7.00
316 SS	3/16"	±0.01%	R5T185L383-012-00-8HN31	155.00	7.00
316 SS	1/4"	±0.01%	R5T185L483-012-00-8HN31	155.00	7.00
316 SS	3/8"	±0.01%	R5T185L683-012-00-8HN31	155.00	7.00

For All Assemblies: To select a longer or shorter element length, just insert (in inches) the length you want in place of the 12 in digits 10 and 11 of the catalog number (*above R5T185L38123-...*) Add \$7.00 for each additional 6" length (or part of 6") over 12".

For Assemblies with Leads: For a longer lead length, just insert your desired length (in inches) in place of the 036 near the end of the catalog number. Price of the additional lead length is \$1.00 per foot.

Optional Termination Head Materials Available!

For Optional Head...	Replace 8HN31 with	Add or Deduct
Aluminum Screw Cover, 1/2" Carbon Steel Hex Fitting	6HN31	-\$8.00
Polypropylene Screw Cover, 1/2" SS Hex Fitting	8HN63	-2.00
Cast Iron Screw Cover, 1/2" SS Hex Fitting	8HN34	6.00
Class B Explosion-Proof Head, 1/2" SS Hex Fitting	8HN72	57.00
Stainless Steel Head, 1/2" SS Hex Fitting	8HN91	107.00



Level Measurement Instruments

Flow Measurement Instruments

Pressure Transmitter

Temperature Sensors and Transmitters

Wireless Sensing and Communications

Analytical Instruments and Systems

RTDs with Threaded Thermowells

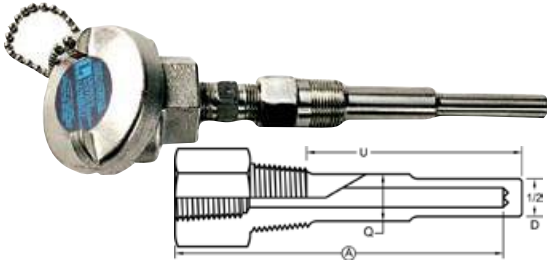

Features

- 3-wire DIN standard 0.00385Ω temperature coefficient
- For temperatures from -328° to 400° F
- Well materials in 304 or 316 stainless steel, brass, or carbon steel
- 1/4" OD, 316 stainless steel sheath
- Aluminum screw cover head
- Accuracy: ±0.1%

We made it easy for you to select RTDs with threaded thermowells.

1. Pick a process thread connection, well length, and material.
2. Add the matching RTD catalog number.
3. Add the prices and part numbers together for a complete priced catalog number.

Model Selection Guide

Well Selection						Material and Price*				RTD Selection	
Process Thread	Stem Length "A"	Insertion Length "U"	Well Diam. "D"	Shank Diam. "Q"	Catalog Number	Brass "B"	Steel "S"	304 SS "304"	316 SS "316"	Catalog Number	Price Each
1/2"	2-1/2"	1-1/8"	1/2"	1/2"	49-*	\$21.45	\$13.86	\$21.45	\$26.73	R1T185L483-02.5-SL-8HN31	\$127.00
1/2"	4"	2-1/2"	1/2"	1/2"	99-*	23.10	16.83	23.10	28.38	R1T185L483-004-SL-8HN31	127.00
1/2"	6"	4-1/2"	1/2"	5/8"	185-U4 1/2 -*	29.37	21.12	29.37	35.97	R1T185L483-006-SL-8HN31	127.00
1/2"	9"	7-1/2"	1/2"	5/8"	185-U7 1/2 -*	44.59	35.71	44.59	59.99	R1T185L483-009-SL-8HN31	127.00
1/2"	12"	10-1/2"	1/2"	5/8"	185-U10 1/2 -*	54.57	46.15	54.57	73.37	R1T185L483-012-SL-8HN31	127.00
1/2"	15"	13-1/2"	1/2"	5/8"	185-U13 1/2 -*	69.63	58.21	69.63	94.45	R1T185L483-015-SL-8HN31	134.00
1/2"	18"	16-1/2"	1/2"	5/8"	185-U16 1/2 -*	84.69	70.27	84.69	115.52	R1T185L483-018-SL-8HN31	134.00
1/2"	24"	22-1/2"	1/2"	5/8"	185-U22 1/2 -*	114.82	94.40	114.82	157.69	R1T185L483-024-SL-8HN31	141.00
3/4"	2-1/2"	1-5/8"	1/2"	1/2"	50-*	21.45	13.86	21.45	26.73	R1T185L483-02.5-SL-8HN31	127.00
3/4"	4"	2-1/2"	1/2"	1/2"	100-*	23.10	16.83	23.10	28.38	R1T185L483-004-SL-8HN31	127.00
3/4"	6"	4-1/2"	1/2"	3/4"	200-U4 1/2 -*	29.37	21.12	29.37	35.97	R1T185L483-006-SL-8HN31	127.00
3/4"	9"	7-1/2"	1/2"	3/4"	200-U7 1/2 -*	44.59	35.64	44.59	59.99	R1T185L483-009-SL-8HN31	127.00
3/4"	12"	10-1/2"	1/2"	3/4"	200-U10 1/2 -*	54.57	46.15	54.57	73.37	R1T185L483-012-SL-8HN31	127.00
3/4"	15"	13-1/2"	1/2"	3/4"	200-U13 1/2 -*	69.63	58.21	69.63	94.45	R1T185L483-015-SL-8HN31	134.00
3/4"	18"	16-1/2"	1/2"	3/4"	200-U16 1/2 -*	84.69	70.27	84.69	115.52	R1T185L483-018-SL-8HN31	134.00
3/4"	24"	22-1/2"	1/2"	3/4"	200-U22 1/2 -*	114.82	94.40	114.82	157.69	R1T185L483-024-SL-8HN31	141.00
1"	2-1/2"	1-5/8"	1/2"	1/2"	51-*	25.74	19.47	25.74	32.01	R1T185L483-02.5-SL-8HN31	127.00
1"	4"	2-1/2"	1/2"	1/2"	101-*	31.35	24.75	31.35	36.96	R1T185L483-004-SL-8HN31	127.00
1"	6"	4-1/2"	1/2"	7/8"	201-U4 1/2 -*	42.24	29.04	42.24	48.51	R1T185L483-006-SL-8HN31	127.00
1"	9"	7-1/2"	1/2"	7/8"	201-U7 1/2 -*	54.57	46.15	54.57	73.37	R1T185L483-009-SL-8HN31	127.00
1"	12"	10-1/2"	1/2"	7/8"	201-U10 1/2 -*	67.53	52.16	67.53	90.77	R1T185L483-012-SL-8HN31	127.00
1"	15"	13-1/2"	1/2"	7/8"	201-U13 1/2 -*	87.13	67.23	87.13	111.86	R1T185L483-015-SL-8HN31	134.00
1"	18"	16-1/2"	1/2"	7/8"	201-U16 1/2 -*	106.73	82.29	106.73	142.64	R1T185L483-018-SL-8HN31	134.00
1"	24"	22-1/2"	1/2"	7/8"	201-U22 1/2 -*	145.94	112.41	145.94	194.50	R1T185L483-024-SL-8HN31	141.00

*Replace the asterisk with the letter or number in quotes under material (i.e., B=Brass, S=Steel, 304=304SS, etc.)

Optional Termination Head Materials Available!

For Optional Head...	Replace 8HN31 with	Add or Deduct
Polypropylene Screw Cover, 1/2" SS Hex Fitting	8HN63	\$-2.00
Cast Iron Screw Cover, 1/2" SS Hex Fitting	8HN34	6.00
Explosion-Proof Screw Cover, 1/2" SS Hex Fitting	8HN74	59.00
316L Stainless Steel Head, 1/2" SS Hex Fitting	8HN91	107.00

Order a Complete Field-Mount RTD and Transmitter Assembly



Specifications

- Output:** 4-20 mA signal
- Current:** ≤ 3.5 mA input required; ≤ 23 mA limit
- Power Supply:** 10 to 35 VDC polarity protected
- Ambient Temperature:** -40° to 185° F
- Construction:** Polycarbonate housing, polyurethane potting
- Ingress Protection:** IP00/IP54 installed in sensor head
- Vibration Protection:** 4g (2-150Hz) per IEC 60 068-2-6
- EMC Immunity:** Interference immunity and emission per EN 61 326-1



Adding Head-Mounted Transmitter

Description	Catalog Number	Price
440 Programmable Temperature Transmitter 3-Wire Pt100Ω RTD (alpha = 0.00385)	,T-440-	\$110.00
Fault Upscale Burnout (20.5 mA)	385U-	0.00
Signal Downscale Burnout (3.8 mA)	385D-	0.00
Range Lower Limit – Upper Limit (Numeric)	S(_____-_____-)	0.00
Scale Celsius	C	0.00
Fahrenheit	F	0.00

3 RTDs for the Food Industry

All RTDs are DIN standard with a temperature coefficient of 0.00385. Temperature limit is 400° F max..

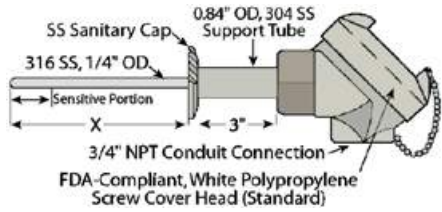

Clean-In-Place (CIP) RTDs

(Above) All our CIP RTDs exceed the 3A Sanitary Council Standard #09-08, making them perfect for use in dairy and food processing. They are available in ±0.1% or ±0.01% accuracies. The polypropylene head is ideal for washdown areas. Please allow 5-7 days for delivery.

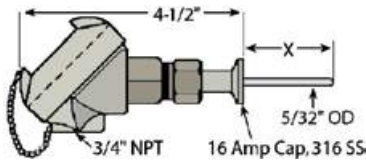

Mini Sanitary CIP RTDs

(Above) These miniature sanitary CIP RTDs come with a 16 Amp Triclover cap to fit 1/2" and 3/4" tube size sanitary fittings, and meet 3A Sanitary Council Standard #09-08. Please allow 3 weeks for delivery. Express delivery (3-5 days) is available. Call for details.

Fast Response RTDs for HTST Applications

(At Right) When an RTD is used in a HTST (High Temperature Short Time) application, the FDA requires it to respond in less than 4 seconds. So, our HTST fast response RTD is perfect — it meets 3A and the FDA time requirements. The polypropylene head is great for washdown areas, and includes wire seal security screws. Please allow 5-7 days for delivery.

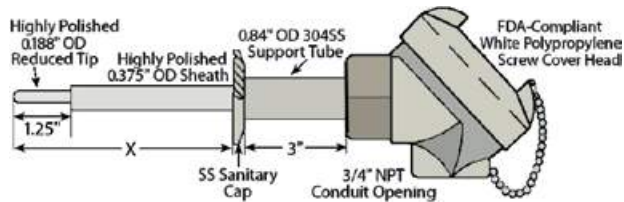

Sanitary CIP RTDs: 1/4" O.D. Sheath Diameter

Immersion Length	Cap Size and Type	Accuracy	Catalog Number	Price
4"	1-1/2" Triclover 16 AMP	±0.1%	R1T185L483-04-CIP-1-5-63	\$130.00
4"	1-1/2" Triclover 16 AMP	±0.01%	R5T185L483-04-CIP-1-5-63	163.00
4"	2" Triclover 16 AMP	±0.1%	R1T185L483-04-CIP-2-5-63	142.00
4"	2" Triclover 16 AMP	±0.01%	R5T185L483-04-CIP-2-5-63	175.00
5"	1-1/2" Triclover 16 AMP	±0.1%	R1T185L483-05-CIP-1-5-63	130.00
5"	1-1/2" Triclover 16 AMP	±0.01%	R5T185L483-05-CIP-1-5-63	163.00
5"	2" Triclover 16 AMP	±0.1%	R1T185L483-05-CIP-2-5-63	142.00
5"	2" Triclover 16 AMP	±0.01%	R5T185L483-05-CIP-2-5-63	175.00
5"	2-1/2" Triclover 16 AMP	±0.1%	R1T185L483-05-CIP-3-5-63	144.00
5"	2-1/2" Triclover 16 AMP	±0.01%	R5T185L483-05-CIP-3-5-63	177.00
6"	1-1/2" Triclover 16 AMP	±0.1%	R1T185L483-06-CIP-1-5-63	130.00
6"	1-1/2" Triclover 16 AMP	±0.01%	R5T185L483-06-CIP-1-5-63	163.00
6"	2" Triclover 16 AMP	±0.1%	R1T185L483-06-CIP-2-5-63	142.00
6"	2" Triclover 16 AMP	±0.01%	R5T185L483-06-CIP-2-5-63	175.00
6"	2-1/2" Triclover 16 AMP	±0.1%	R1T185L483-06-CIP-3-5-63	144.00
6"	2-1/2" Triclover 16 AMP	±0.01%	R5T185L483-06-CIP-3-5-63	177.00
6"	3" Triclover 16 AMP	±0.1%	R1T185L483-06-CIP-4-5-63	164.00
6"	3" Triclover 16 AMP	±0.01%	R5T185L483-06-CIP-4-5-63	197.00

Mini Sanitary CIP RTDs: 5/32" O.D. Sheath Diameter

Immersion Length	Cap Size and Type	Accuracy	Catalog Number	Price
2"	1/2" Triclover 16 AMP	±0.1%	R1T185(156)83-02-CIP-075-5-63	\$174.00
2"	1/2" Triclover 16 AMP	±0.01%	R5T185(156)83-02-CIP-075-5-63	202.00
2"	3/4" Triclover 16 AMP	±0.1%	R1T185(156)83-02-CIP-075-5-63	174.00
2"	3/4" Triclover 16 AMP	±0.01%	R5T185(156)83-02-CIP-075-5-63	202.00
4"	1/2" Triclover 16 AMP	±0.1%	R1T185(156)83-04-CIP-075-5-63	174.00
4"	1/2" Triclover 16 AMP	±0.01%	R5T185(156)83-04-CIP-075-5-63	202.00
4"	3/4" Triclover 16 AMP	±0.1%	R1T185(156)83-04-CIP-075-5-63	174.00
4"	3/4" Triclover 16 AMP	±0.01%	R5T185(156)83-04-CIP-075-5-63	202.00

HTST RTDs: 3/8" O.D. Sheath Diameter

Immersion Length	Cap Size and Type	Accuracy	Catalog Number	Price
4"	1-1/2" Triclover 16 AMP	±0.01%	R5T185L68R383-04-HTST-1-5-63-HS	\$174.00
4"	2" Triclover 16 AMP	±0.01%	R5T185L68R383-04-HTST-2-5-63-HS	186.00
5"	1-1/2" Triclover 16 AMP	±0.01%	R5T185L68R383-05-HTST-1-5-63-HS	174.00
5"	2" Triclover 16 AMP	±0.01%	R5T185L68R383-05-HTST-2-5-63-HS	186.00

We have all kinds of devices to take the signals from your temperature sensors!



Recorders See page 237



Controllers See page 195



Panel Meters See page 225



Temperature Transmitters See page 110

Level Measurement Instruments
Flow Measurement Instruments
Pressure Transmitter
Temperature Sensors and Transmitters
Wireless Sensing and Communications
Analytical Instruments and Systems

General Purpose Thermocouple Assemblies with Leads

Features

- Available in any length
- Inconel or 316 stainless steel sheath
- Transition fitting with spring relief good to 1000° F *
- Use with compression fittings
- Bend to any configuration you need
- 36" 24-gauge Teflon leadwire standard
Need a different sheath material or a dual

Thermocouple Type	Suggested Range
J	32° to 1400° F
K	32° to 2300° F
E	32° to 1600° F
T	-300° to 700° F

Do not use 316 SS above 1700° F. (Max temp varies by sheath diameter.)

* Transition Fittings Note: For use at temperatures above 500° F, please specify fiberglass wire: 11_ _ _ for temps to 900° F, 21_ _ _ for temps to 1300° F (Types J, K only).



Model Selection Guide

Sheath		12" Sheath Length Catalog Number	Price Each*		Price Adder per +6" Length
Material	Diam.		Grounded/ Exposed	Un- grounded	
Type J (Iron Constantan) Thermocouple					
316 SS	1/16"	J18(*)-012-00-15HT-T1036-2	\$43.20	\$46.20	\$1.90
316 SS	1/8"	J28(*)-012-00-15HT-T1036-2	36.50	39.50	1.80
316 SS	3/16"	J38(*)-012-00-15HT-T1036-2	39.40	42.40	2.90
316 SS	1/4"	J48(*)-012-00-15HT-T1036-2	42.80	45.80	3.90
Type K (Chromel-Alumel) Thermocouple					
Inconel	1/8"	K23(*)-012-00-15HT-T1036-2	39.90	42.90	2.70
Inconel	3/16"	K33(*)-012-00-15HT-T1036-2	43.80	46.80	4.40
Inconel	1/4"	K43(*)-012-00-15HT-T1036-2	52.50	55.50	7.00
316 SS	1/8"	K28(*)-012-00-15HT-T1036-2	37.70	40.70	1.80
316 SS	3/16"	K38(*)-012-00-15HT-T1036-2	40.60	43.60	2.90
316 SS	1/4"	K48(*)-012-00-15HT-T1036-2	44.00	47.00	3.90
Type E (Chromel-Constantan) Thermocouple, Fiberglass Leadwire					
316 SS	1/16"	E18(*)-012-00-15HT-F1036-2	40.10	43.10	1.90
316 SS	1/8"	E28(*)-012-00-15HT-F1036-2	35.60	38.60	1.80
316 SS	3/16"	E38(*)-012-00-15HT-F1036-2	38.60	41.60	2.90
316 SS	1/4"	E48(*)-012-00-15HT-F1036-2	42.10	45.10	4.90
Type T (Copper-Constantan) Thermocouple					
316 SS	1/16"	T18(*)-012-00-15HT-T1036-2	40.50	43.50	1.50
316 SS	1/8"	T28(*)-012-00-15HT-T1036-2	35.00	38.00	1.90
316 SS	3/16"	T38(*)-012-00-15HT-T1036-2	38.40	41.40	2.90
316 SS	1/4"	T48(*)-012-00-15HT-T1036-2	43.80	46.80	4.70

Please specify junction type: G=Grounded, E=Exposed, U=Ungrounded. Insert the correct letter designation in place of the () for a complete catalog number.

To select a longer or shorter custom sheath length, insert the desired length (in inches) in the three digits before the (*) (012=12" as shown above). For lengths over 12", be sure to include the appropriate price adder per 6" additional length. There is no price reduction for lengths under 12". For longer lead lengths, insert the desired length (in inches) in the three digits near the end of the catalog number (036=36" as shown above). For each additional 12" length, add \$1.00 to the price.

General Purpose Thermocouples

Thermocouples with Quick-Disconnect Plugs

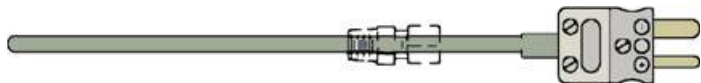

Features

- Available in any length
- Inconel or 316 stainless steel sheath (316 SS good to 1700° F, Inconel good to 2100° F; varies by sheath diameter)
- Plug and jack good to 350° F
- Use with compression fittings
- Bend to any configuration

Great for applications where you need to easily disconnect the thermocouple from the leadwires. You can also attach any length leadwire you want, just by ordering your desired length of thermocouple extension wire.

Need a dual element of different sheath material? Give us a call. We can get just about anything you can describe.

Model Selection Guide

Sheath		12" Length Catalog Number	Price Each*		Price Adder per +6" Length
Material	Diam.		Grounded/Exposed	Un-grounded	
Type J (Iron Constantan) Thermocouple					
316 SS	1/16"	J18(*)-012-00-04	\$25.90	\$28.90	\$1.90
316 SS	1/8"	J28(*)-012-00-04	23.20	26.20	1.80
316 SS	3/16"	J38(*)-012-00-04	25.10	28.10	2.90
316 SS	1/4"	J48(*)-012-00-04	29.50	32.50	3.90
Type K (Chromel-Alumel) Thermocouple					
Inconel	1/8"	K23(*)-012-00-04	25.40	28.40	2.70
Inconel	3/16"	K33(*)-012-00-04	29.30	32.30	4.40
Inconel	1/4"	K43(*)-012-00-04	38.00	41.00	7.00
316 SS	1/16"	K18(*)-012-00-04	25.90	28.90	1.20
316 SS	1/8"	K28(*)-012-00-04	23.20	26.20	1.80
316 SS	3/16"	K38(*)-012-00-04	26.10	29.10	2.90
316 SS	1/4"	K48(*)-012-00-04	29.50	32.50	3.90
Type E (Chromel-Constantan) Thermocouple					
316 SS	1/16"	E18(*)-012-00-04	26.80	29.80	1.90
316 SS	1/8"	E28(*)-012-00-04	22.30	25.30	1.80
316 SS	3/16"	E38(*)-012-00-04	25.30	28.30	2.90
316 SS	1/4"	E48(*)-012-00-04	28.80	31.80	4.90
Type T (Copper-Constantan) Thermocouple					
316 SS	1/16"	T18(*)-012-00-04	27.20	30.20	1.50
316 SS	1/8"	T28(*)-012-00-04	21.70	24.70	1.90
316 SS	3/16"	T38(*)-012-00-04	25.10	28.10	2.90
316 SS	1/4"	T48(*)-012-00-04	30.50	33.50	4.70

Please specify junction type: G=Grounded, E=Exposed, U=Ungrounded. Insert the correct letter designation in place of the () for a complete catalog number.

To select a longer or shorter custom sheath length, insert the desired length (in inches) in the three digits before the (*) (012=12" as shown above). For lengths over 12", include the appropriate price adder per 6" additional length. There is no price reduction for lengths under 12".

For details on thermocouple initial material tolerances and thermocouple type color codes, see page 495.

MgO Insulated Thermocouples

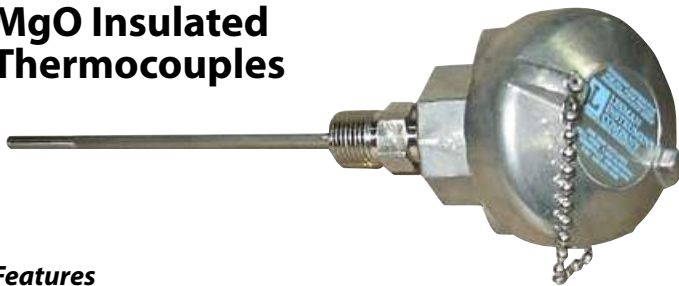

Features

- Use with compression fittings
- 1/2" NPT process and conduit connections
- Inconel or 316 stainless steel sheath (Inconel good to 2100° F; Varies by sheath diameter)

If you need a dual element or different sheath material, give us a call. We have most materials available. Please remember that when wiring thermocouples, red is always negative.

Model Selection Guide

Sheath		12" Length Catalog Number	Price Each*		Price Adder Each +6"
Material	Diam.		Grounded/Exposed	Un-grounded	
Type J (Iron Constantan) Thermocouple, 32° to 1400° F					
316 SS	1/8"	J28(*)-012-00-8HN31	\$72.70	\$75.70	\$1.80
316 SS	3/16"	J38(*)-012-00-8HN31	75.60	78.60	2.90
316 SS	1/4"	J48(*)-012-00-8HN31	79.00	82.00	3.90
Type K (Chromel-Alumel) Thermocouple, 32° to 2300° F**					
Inconel	1/8"	K23(*)-012-00-8HN31	74.90	77.90	2.70
Inconel	3/16"	K33(*)-012-00-8HN31	78.80	81.80	4.40
Inconel	1/4"	K43(*)-012-00-8HN31	87.50	90.50	7.00
316 SS	1/8"	K28(*)-012-00-8HN31	72.70	75.70	1.80
316 SS	3/16"	K38(*)-012-00-8HN31	75.60	78.60	2.90
316 SS	1/4"	K48(*)-012-00-8HN31	79.00	82.00	3.90
Type E (Chromel-Constantan) Thermocouple, 32° to 1600° F**					
316 SS	1/8"	E28(*)-012-00-8HN31	71.80	74.80	1.80
316 SS	3/16"	E38(*)-012-00-8HN31	74.80	77.80	2.90
316 SS	1/4"	E48(*)-012-00-8HN31	78.30	81.30	4.90
Type T (Copper-Constantan) Thermocouple, -300° to 700° F					
316 SS	1/8"	T28(*)-012-00-8HN31	71.20	74.20	1.90
316 SS	3/16"	T38(*)-012-00-8HN31	74.60	77.60	2.90
316 SS	1/4"	T48(*)-012-00-8HN31	80.00	83.00	4.70

Please specify junction type: G=Grounded, E=Exposed, U=Ungrounded. Insert the correct letter designation in place of the ().

**Do not use 316 SS above 1650° F

To select a longer or shorter custom sheath length, insert the desired length (in inches) in the three digits before the (*) (012=12" as shown above). For lengths over 12", be sure to include the appropriate price adder per 6" additional length. There is no price reduction for lengths under 12".

Optional Termination Head Materials Available!

For Optional Head...	Replace -31 with	Add to Price
Polypropylene Screw Cover	-63	\$-2.00
Cast Iron Screw Cover	-34	6.00
Aluminum Explosion Proof	-74	59.00
Stainless Steel Head	-91	107.00

For thermocouple extension wire, see page 105. Need a compression fitting? Call us!

Level Measurement Instruments

Flow Measurement Instruments

Pressure Transmitter

Temperature Sensors and Transmitters

Wireless Sensing and Communications

Analytical Instruments and Systems

Thermocouples with Matching Thermowells



- Our most commonly requested thermocouples and matching thermowells
- Most common materials listed
- Complete with cast aluminum protection head
- Wells available with 1/2", 3/4", and 1" process connections

We've made it easy for you to select thermocouples with matching thermowells. It's as easy as 1, 2, 3!

1. Select the process connection, well length, and material.
2. Add the matching thermocouple, just by inserting the thermocouple type desired in place of the ?
3. Add the 2 prices and part numbers together and you have a complete catalog number with pricing!

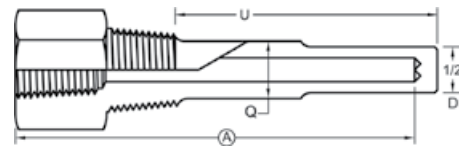

Already have a thermowell, but need a replacement thermocouple? Just find the thermowell dimensions in the chart and select the thermocouple. It's that easy!

We use only spring-loaded thermocouples with our thermowells. Why? Because spring-loading ensures positive contact with the thermowell tip, so the sensor responds faster to temperature changes.

Standard sheath material of the thermocouples is 316 stainless steel and the 1/2" NPT connection that goes into the thermowell is carbon steel. Other materials (Inconel) are available if you are sensing temperatures above 1650° F. For more information, just give us a call, we can make just about anything you can describe.

Model Selection Guide

Well Selection						Material and Price*					Thermocouple Selection	
Process Thread	Stem Length "A"	Insertion Length "U"	Well Diam. "D"	Shank Diam. "Q"	Catalog Number	Brass "B"	Steel "S"	304 SS "304"	316 SS "316"	Catalog Number	Price Each	
1/2"	2-1/2"	1-1/8"	1/2"	1/2"	49-*	\$21.45	\$13.86	\$21.45	\$26.73	248U-02.5-SL-6HN31	\$78.00	
1/2"	4"	2-1/2"	1/2"	1/2"	99-*	23.10	16.83	23.10	28.38	248U-004-SL-6HN31	78.00	
1/2"	6"	4-1/2"	1/2"	5/8"	185-U4 1/2-*	29.37	21.12	29.37	35.97	248U-006-SL-6HN31	78.00	
1/2"	9"	7-1/2"	1/2"	5/8"	185-U7 1/2-*	44.59	35.71	44.59	59.99	248U-009-SL-6HN31	78.00	
1/2"	12"	10-1/2"	1/2"	5/8"	185-U10 1/2-*	54.57	46.15	54.57	73.37	248U-012-SL-6HN31	78.00	
1/2"	15"	13-1/2"	1/2"	5/8"	185-U13 1/2-*	69.63	58.21	69.63	94.45	248U-015-SL-6HN31	81.90	
1/2"	18"	16-1/2"	1/2"	5/8"	185-U16 1/2-*	84.69	70.27	84.69	115.52	248U-018-SL-6HN31	81.90	
1/2"	24"	22-1/2"	1/2"	5/8"	185-U22 1/2-*	114.82	94.40	114.82	157.69	248U-024-SL-6HN31	85.80	
3/4"	2-1/2"	1-5/8"	1/2"	1/2"	50-*	21.45	13.86	21.45	26.73	248U-02.5-SL-6HN31	78.00	
3/4"	4"	2-1/2"	1/2"	1/2"	100-*	23.10	16.83	23.10	28.38	248U-004-SL-6HN31	78.00	
3/4"	6"	4-1/2"	1/2"	3/4"	200-U4 1/2-*	29.37	21.12	29.37	35.97	248U-006-SL-6HN31	78.00	
3/4"	9"	7-1/2"	1/2"	3/4"	200-U7 1/2-*	44.59	35.64	44.59	59.99	248U-009-SL-6HN31	78.00	
3/4"	12"	10-1/2"	1/2"	3/4"	200-U10 1/2-*	54.57	46.15	54.57	73.37	248U-012-SL-6HN31	78.00	
3/4"	15"	13-1/2"	1/2"	3/4"	200-U13 1/2-*	69.63	58.21	69.63	94.45	248U-015-SL-6HN31	81.90	
3/4"	18"	16-1/2"	1/2"	3/4"	200-U16 1/2-*	84.69	70.27	84.69	115.52	248U-018-SL-6HN31	81.90	
3/4"	24"	22-1/2"	1/2"	3/4"	200-U22 1/2-*	114.82	94.40	114.82	157.69	248U-024-SL-6HN31	85.80	
1"	2-1/2"	1-5/8"	1/2"	1/2"	51-*	25.74	19.47	25.74	32.01	248U-02.5-SL-6HN31	78.00	
1"	4"	2-1/2"	1/2"	1/2"	101-*	31.35	24.75	31.35	36.96	248U-004-SL-6HN31	78.00	
1"	6"	4-1/2"	1/2"	7/8"	201-U4 1/2-*	42.24	29.04	42.24	48.51	248U-006-SL-6HN31	78.00	
1"	9"	7-1/2"	1/2"	7/8"	201-U7 1/2-*	54.57	46.15	54.57	73.37	248U-009-SL-6HN31	78.00	
1"	12"	10-1/2"	1/2"	7/8"	201-U10 1/2-*	67.53	52.16	67.53	90.77	248U-012-SL-6HN31	78.00	
1"	15"	13-1/2"	1/2"	7/8"	201-U13 1/2-*	87.13	67.23	87.13	111.86	248U-015-SL-6HN31	81.90	
1"	18"	16-1/2"	1/2"	7/8"	201-U16 1/2-*	106.73	82.29	106.73	142.64	248U-018-SL-6HN31	81.90	
1"	24"	22-1/2"	1/2"	7/8"	201-U22 1/2-*	145.94	112.41	145.94	194.50	248U-024-SL-6HN31	85.80	

- Please specify thermowell material by replacing * in catalog number with the appropriate letter or number designation (B, S, 304, or 316).
- Replace the ? in the thermocouple part number with the thermocouple type you need (J or K, E, or T).

Prices shown are for Type J or K thermocouple.

**For thermocouple extension wire, see page 105.
Need a compression fitting? Call us!**

Please remember that when wiring thermocouples, red is always negative.

Optional Termination Head Materials Available!

For Optional Head...	Replace -31 with	Add to Price
Cast Iron Screw Cover	-34	\$6.00
Aluminum Explosion Proof	-74	59.00
Stainless Steel Head	-91	107.00

For information on thermocouple initial material tolerances and thermocouple type color codes, see page 495.

Metal Protection Tube Thermocouple Assemblies

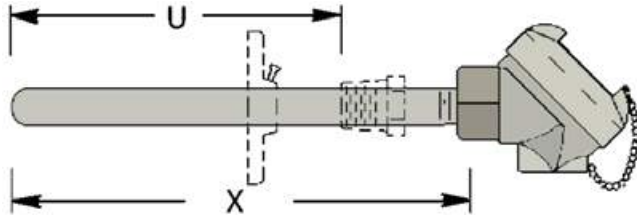

All assemblies on this page include our standard cast iron screw cover head with terminal block.

Make one selection from each table section. *Example:* J11C-8-50-18-H-8D12 is a Type J11 gauge thermocouple with a 18" 316 SS protection tube, 3/4" NPT 316 SS. Bushing welded 12" from the tip with an adjustable steel mounting flange.

Protection Tube X X = Length (In.)	Tube Size	Catalog Number	Length				
			12"	18"	24"	30"	36"
Type J (Iron Constantan) Thermocouple — 8 Gauge Element							
316 Stainless Steel	1/2"	J8C-8-50-X X-34	\$79.20	\$92.90	\$106.60	\$120.30	\$134.00
316 Stainless Steel	3/4"	J8C-8-75-X X-34	82.20	96.90	111.60	126.30	141.00
Inconel 601	1/2"	J8C-7-50-X X-34	157.20	208.90	260.60	312.30	364.00
Inconel 601	3/4"	J8C-7-75-X X-34	189.20	257.40	325.60	393.80	462.00
Type J (Iron Constantan) Thermocouple — 14 Gauge Element							
316 Stainless Steel	1/2"	J14C-8-50-X X-34	74.10	85.30	96.50	107.70	118.90
Inconel 601	1/2"	J14C-7-50-X X-34	152.10	201.30	250.50	299.70	348.90
Type K (Chromel-Alumel) Thermocouple — 8 Gauge Element							
316 Stainless Steel	1/2"	K8C-8-50-X X-34	83.00	98.60	114.20	129.80	145.40
316 Stainless Steel	3/4"	K8C-8-75-X X-34	86.00	102.60	119.20	135.80	152.40
Inconel 601	1/2"	K8C-7-50-X X-34	161.00	214.60	268.20	321.80	375.40
Inconel 601	3/4"	K8C-7-75-X X-34	193.00	263.10	333.20	403.30	473.40
Type K (Chromel-Alumel) Thermocouple — 11 Gauge Element							
316 Stainless Steel	1/2"	K11C-8-50-X X-34	79.70	93.60	107.50	121.40	135.30
316 Stainless Steel	3/4"	K11C-8-75-X X-34	82.70	97.60	112.50	127.40	142.30
Inconel 601	1/2"	K11C-7-50-X X-34	157.70	209.60	261.50	313.40	365.30
Inconel 601	3/4"	K11C-7-75-X X-34	193.00	261.40	329.80	398.20	466.60
Type K (Chromel-Alumel) Thermocouple — 14 Gauge Element							
316 Stainless Steel	1/2"	K14C-8-50-X X-34	75.00	86.60	98.20	109.80	121.40
Inconel 601	1/2"	K14C-7-50-X X-34	153.00	202.60	252.20	301.80	351.40
Assembly Options (Omit if no option is required.)			Catalog Number		Price		
Adjustable Steel Mounting Flange			-H-		21.00		
Cast Iron/Aluminum Explosion-Proof Head			-93-		56.00		
Thermocouple Insulated from Protection Tube			-L-		9.00		
3/4" NPT Steel Welded Bushing (1/2" Pipe Only)			-6D U U*		25.00		
1" NPT Steel Welded Bushing (1/2"/3/4" Pipe Only)			-6E U U*		25.00		
1 1/4" NPT Steel Welded Bushing (1/2"/3/4"/1" Pipe Only)			-6F U U*		25.00		
1 1/2" NPT Steel Welded Bushing (1/2"/3/4"/1" Pipe Only)			-6G U U*		25.00		
3/4" NPT 316 SS Welded Bushing (1/2" Pipe Only)			-8D U U*		75.00		
1" NPT 316 SS Welded Bushing (1/2"/3/4" Pipe Only)			-8E U U*		75.00		
1 1/4" NPT 316 SS Welded Bushing (1/2"/3/4"/1" Pipe Only)			-8F U U*		75.00		
1 1/2" NPT 316 SS Welded Bushing (1/2"/3/4"/1" Pipe Only)			-8G U U*		75.00		

U U* = Substitute the insertion length (in inches) measured from tip to bottom of bushing for the U U. Omit this length if you would like the bushing supplied loose on the protection tube.

Need Thermocouple Parts or Accessories?

All of our thermocouple parts and accessories are available to ship within 5 working days! Call for current pricing and available materials and sizes.

Straight Elements



Straight Bare Elements



Angle Elements

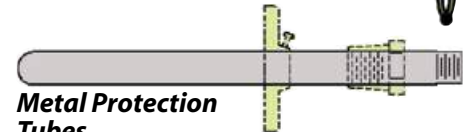

Metal Protection Tubes

Readjustable Compression and Spring-Loaded Fittings

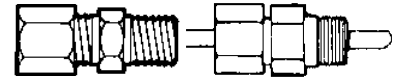

Thermocouple Alloy Terminal Blocks

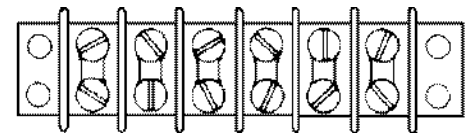

Spade Lugs and Terminal Lugs

Standard Size and Mini Jack Panels

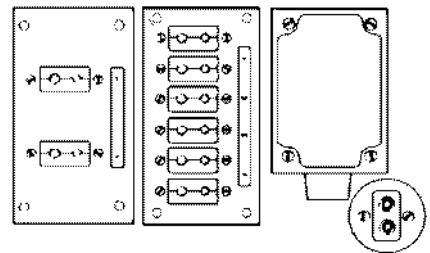

Thermocouple Element Insulators



Level Measurement Instruments

Flow Measurement Instruments

Pressure Transmitter

Temperature Sensors and Transmitters

Wireless Sensing and Communications

Analytical Instruments and Systems

Thermocouple Wire and Thermocouple/RTD Extension Wire

Helpful Hints

1. Use thermocouple wire to make thermocouple elements or to connect thermocouples to instrumentation. **Extension wire should be used only to connect thermocouples to instrumentation.** Match the wire with the thermocouple to be used.
2. Select wire insulation compatible with the application environment. For applications requiring moisture resistance, use Teflon, PVC, Kapton, and Tefzel. For applications requiring high temperature insulations, use fiber-glass, Vitreous Silica, and ceramic fiber.
3. Use stranded conductor wire to connect thermocouples where continuous or frequent flexing of the leadwire occurs.
4. Use metal overbraids and leads in flexible armor to provide protection against physical abuse to wiring.
5. Use leadwire with aluminum Mylar shields and drain wires to connect sensors to computers and protect against EMF stray signals.
6. **Do not** run thermocouple leads in conduits that carry power wiring. **Do not** run conduit carrying thermocouple leads parallel to electric buss bars or heavy power-carrying conduits. Cross them at right angles.
7. When connecting these wires to instrumentation, **red is always negative.** The other color-coded wire is **always positive.**



We reserve the right to ship ±10% of the length ordered, unless an exact requirement is clearly specified on the order.

Thermocouple Wire and Thermocouple Extension Wire

*Standard lengths are 50, 100, 250, 500, and 1000 feet.

Wire Gauge	Wire Type	Insulations		Continuous Temp. Rating	Abrasion Resistance	Moisture Resistance	Catalog Number	Price per Foot	
		Each Conductor	Exterior Cover					Std.* Length	Non-Std. Length
Thermocouple Wire Type J ANSI Color Code: Negative Wire = Red, Positive Wire = White, Overall = Brown									
20	Solid	Glass Braid	Glass Braid	900° F	Fair	Good	J20-1-304	\$0.38	\$0.43
20	Solid	Teflon (FEP) Extruded	Teflon (FEP) Extruded	400° F	Very Good	Excellent	J20-1-507	0.56	0.61
20	Strd.	Teflon (FEP) Extruded	Teflon (FEP) Extruded	400° F	Very Good	Excellent	J20-3-507	0.76	0.81
Thermocouple Extension Wire Type JX ANSI Color Code: Negative Wire = Red, Positive Wire = White, Overall = Black									
16	Solid	Polyvinyl	Polyvinyl	-20 to 221° F	Good	Excellent	J16-5-502	0.58	0.63
20	Solid	Polyvinyl	Polyvinyl	-20 to 221° F	Good	Excellent	J20-5-502	0.27	0.32
20	Solid	Polyvinyl	Twisted, Alum. Mylar PVC	-20 to 221° F	Good	Excellent	J20-5-510	0.30	0.35
20	Strd.	Polyvinyl	Polyvinyl	-20 to 221° F	Good	Excellent	J20-7-502	0.30	0.35
Thermocouple Wire Type K ANSI Color Code: Negative = Red; Positive = Yellow, Overall = Brown									
20	Solid	Glass Braid	Glass Braid	900° F	Fair	Good	K20-1-304	0.63	0.68
20	Solid	Teflon (FEP) Extruded	Teflon (FEP) Extruded	400° F	Very Good	Excellent	K20-1-507	0.78	0.83
Thermocouple Extension Wire Type KX ANSI Color Code: Negative Wire = Red, Positive Wire = Yellow, Overall = Yellow									
16	Solid	Polyvinyl	Polyvinyl	-20 to 221° F	Good	Excellent	K16-5-502	0.98	1.03
20	Solid	Polyvinyl	Polyvinyl	-20 to 221° F	Good	Excellent	K20-5-502	0.50	0.55
Thermocouple Extension Wire Type SX and RX ANSI Color Code: Negative Wire = Red, Positive Wire = Black, Overall = Green									
16	Solid	TFE Tape/Heavy Glass Braid	ServTex Braid	Up to 550° F	Good	Good	S16-5-157	1.24	1.29
20	Solid	Glass Braid	Glass Braid	Up to 900° F	Fair	Good	S20-5-304	0.43	0.48

Special Construction RTD Extension Wire

Wire Type	Construction Style	Each Conductor	Insulation Inner Jacket	Insulation Outer Jacket	Temp. Rating	Color Code	Outer Jacket	Catalog Number	Price* per Ft.
Triplex	24-Stranded (Silver-Plated Copper)	TFE Teflon	None	FEP Teflon	400° F	Red, Red, Wht.	White	RT24-3-527	\$0.88

Plugs and Jacks

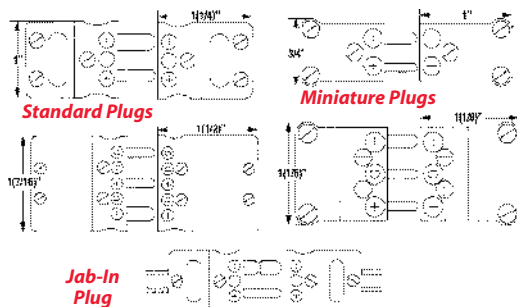

Description	Pin Spacing	Temp Rating	Plugs		Jacks	
			Catalog No	Price	Catalog No	Price
Two Hollow Pins	7/16"	392° F	81_	\$4.30	82_	\$4.40
Three Hollow Pins	7/16"	392° F	81_-3	6.50	82_-3	7.10
Two Jab-In Solid Pins, 14Ga max.	7/16"	392° F	81_-J	10.30	82_-J	11.40
Two Solid Pins	7/16"	662° F	81_-H	12.20	82_-H	12.90
Two Pins	5/16"	392° F	83_	4.10	84_	4.10
Three Pins	5/16"	392° F	83_-3	5.50	84_-3	5.00

Insert calibration code in _. Use thermocouple type (E, J, K, N*, T, R, S) or U for RTD. *Type N available in 61_ and 63_ only.

Tubeskin Temperature Sensors for Process Furnaces

Why use tubeskin sensors?

Tubeskin measurement determines furnace tube life, trending, and provide safeguards within a system. Using accurate tubeskin sensors, you can safeguard heater operations at your facilities, increase furnace tube life, and increase production.

- **Accuracy** — Provide accurate data to determine tube life assessment.
- **Durability** — Withstand harsh firebox environment for prolonged periods. Tubeskin sensors last a minimum of one turnaround cycle.
- **Easy Installation** — Secure weld attachment to the tube wall fits any pipe size. Fast installation and quick replacement meets tight maintenance schedule during a planned shutdown, gets you back online faster in unplanned downtime situations.
- **Sensitivity** — Tubeskin is able to detect early overheating caused by coke formations. Allows for adjustment of furnace firing.
- **Safety Device** — Monitors temperatures and provides alerts where high temperature is reducing remnant life or exceeding maximum allowable limits.



Furnace Types Compatible with Tubeskin Sensors

Crude: Heats crude for processing in a distillation unit. Crude oil can vary widely with type. Generally hot, with a steady state operation.

Vacuum: Heats crude oil bottoms for further processing in a vacuum distillation unit. Generally hot, with a steady state operation. Coke formation can be an issue.

Coker: Heats heavy oil cuts high in resid and asphaltenes for processing in the coke drum. Premature coke formation in the tubes can be a problem, as well as frequent movement of the furnace during temperature variations and decoking.

Catalytic Reforming: Heats naphtha range oil for processing in reforming reactors. These multi-cell furnaces are hot and often have three dimensional tube movement that can be problematic.



Steam Reformers (SMR): A reaction furnace (catalyst-filled tubes) that create syngas for hydrogen, ammonia, or methanol production. These primary reformers are very hot and generally steady state, but have large tube movement parameters.

Hydroprocessing: For heating feedstock so it can be treated (hydrotreaters) or cracked and treated (hydrocrackers). Generally steady state with coking potential dependent on the material being processed. Typical hydroprocessing unit can handle just about all oil cuts.

Fluid Catalytic Cracking (FCC): Heat up gas pol for processing in the FCC riser, generally a steady state furnace.

Resid/Heavy Oil Processing: Heats heavy oil for processing in asphalt, ROSE, and other heavy oil processing units.

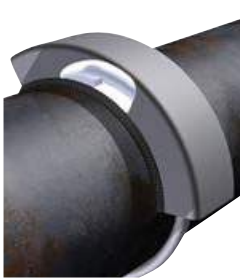
Which Tubeskin Sensor Is Right for You?

				
Criteria	V-Pad	Refracto-Pad	Xtracto-Pad	Weld Pad
Ease of Installation	✓✓✓✓✓	✓✓✓✓	✓✓✓✓	✓✓✓✓✓
Accuracy (Surface)	✓✓✓✓	✓✓✓✓✓	✓✓✓✓✓	✓
Accuracy (Mid-Wall)	✓✓✓✓✓	✓✓✓✓	✓✓✓	✓
Small Sensor Footprint	✓✓✓✓✓	✓✓	✓✓	✓✓✓✓✓
Flame Impingement Concerns	✓✓✓	✓✓✓✓✓	✓✓✓✓✓	✓
Low Temperature Applications (Below 900°F)	✓✓✓✓✓	✓✓✓✓	✓✓✓	✓✓
High Temperature Applications	✓✓✓	✓✓✓	✓✓✓✓✓	✓
Durability (Sensor Life)	✓✓✓	✓✓✓✓	✓✓✓✓✓	✓
Early Coke Detection	✓✓✓✓✓	✓✓✓	✓✓	✓
Replaceability	—	—	✓✓✓✓✓	—

Level Measurement Instruments

Flow Measurement Instruments

Pressure Transmitter

Temperature Sensors and Transmitters

Wireless Sensing and Communications

Analytical Instruments and Systems



V-Pad



- Machined V-shaped block welded to the mineral insulated cable
- Compaction of the mineral insulation inside the V-Pad protects the measuring junction from radiant temperature influences
- No special machining of the V-shaped block is required to match the tube profile
- Thermocouple junction welded into the base of the V-Pad for maximum accuracy and fast response
- Engineering V-shaped block allows a full penetration weld between the junction and tube surface. This eliminates potential air gaps and substantial measurement inaccuracies

Application Criteria

- Designed for critical mid-wall accuracy applications
- Designed for use with crude, vacuum, and coker style furnace applications
- Field-proven for early coke detection to optimize operations and increase production
- Easy installation minimizes downtime
- Adaptable to any size of pipe due to V-shape, reducing spare parts inventory
- Grounded junction
- Longitudinal mounting onto tube

Call for application assistance and pricing.

Refracto-Pad

- Uses a combination of welded pad thermocouple and a heat shield
- Strong welded connection to the process tube
- Patented heat shield with highly opaque, molded insulation
- Shield and sensor profile designed to match tube curvature
- Shield protects the sensor cable, allows for quick routing out of the radiant heat to increase temperature sensor life

Application Criteria

- Designed for high heat flux or difficult applications, up to and including flame impingement
- Patented shielded design ensures reliable readings, even in harsh environments
- Grounded or ungrounded junction
- Radial or longitudinal mounting onto process tube

Call for application assistance and pricing.

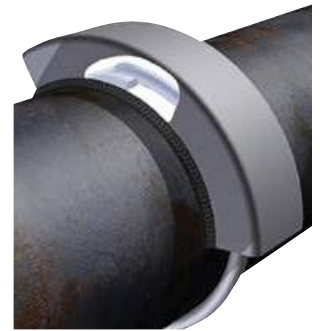

Xtracto-Pad



- Weld pad attached to a guide channel, heat shield
- Removable thermocouple design, so thermocouple can be replaced without any additional grinding, welding, or inspection
- Allows for welded parts to be attached without the presence of the sensor
- Weld pad, guide channel, heat shield and clips can be installed by the heater/boiler manufacturer, or by a specialty tube manufacturer
- Special features help improve reliability of temperature readings

Application Criteria

- For use with catalytic reformers, steam methane/naphtha reformers and reaction furnaces
- Designed for high heat flux or difficult applications, up to and including flame impingement
- Weldable parts can be sent to furnace or tube manufacturer for initial installation
- Patented shielded design ensures reliable readings, even in harsh environments
- Grounded or ungrounded junction
- Radial or longitudinal mounting onto tube

Call for application assistance and pricing.

Weld Pad

- Uses a pad block welded to the furnace tube
- Designed for low temperature (<900° F) applications where accuracy is not critical
- Used for tracking trending temperatures
- Low cost alternative

Application Criteria

- Grounded or ungrounded junction
- Used when flame impingement is not a concern
- Easy installation
- Small sensor footprint

Call for application assistance and pricing.





Services for Tubeskin Sensor Installations

Too many refiners buy a premium furnace tubeskin thermocouple system, only to have it installed by inexperienced personnel. Simple mistakes in installation can dramatically reduce the life and accuracy of a tubeskin thermocouple.

Having experienced factory staff can mean the difference between measurements you trust and readings you don't.

WIKA Gayesco is a world leader in producing furnace tubeskin thermocouple solutions. The Refracto-Pad and Xtracto-Pad are widely accepted by process licensors and major refiners worldwide because of their accuracy and field-proven durability.

Purchasing a WIKA/Gayesco tubeskin thermocouple is a three-part process:

Tubeskin Services from WIKA and Gayesco

From onsite consultation to installation, there's a custom-designed solution for you.

Installation

WIKA/Gayesco Services can provide all manpower, training, and tools required for successful installation of your tubeskin temperature measurement products.

WIKA/Gayesco Services production team performs the installations, so the same experienced people who build the thermocouples are the people who come to your plant to install them.

All team members are familiar with handling these products, and have completed extensive safety training programs in working refining and petrochemical plant environments. Their proven experience gives you an installation you can trust.

Installation Supervision

On-site supervision is available to ensure proper handling and installation of temperature measurement systems. WIKA/Gayesco Services can be involved in any facet you need, from the initial shutdown planning stage to the final loop check.

Welding Services

The service life of temperature assemblies is dependent on proper installation, so all WIKA/Gayesco site welders are qualified to ASME Section IX.

Field Repair

WIKA/Gayesco can assist in repairing or modifying temperature measurement devices in the field. Typical field work includes soldering, welding, splicing, and bending.

In-Situ Field Calibration

WIKA/Gayesco can provide field calibration on thermocouples that are already in place on the process unit. Calibration can be performed anytime the unit is offline, and access to the thermocouple tips is available, like during a turnaround or a catalyst change-out.

Calibration is performed at or near process temperatures in a fast, accurate, repeatable manner by trained technicians.



WIKA Gayesco Services Offering

Complete furnace tubeskin installation:

- Complete welding services by experienced ASME welders
- Professional routing of thermocouples inside the furnace
- Proper connection of the thermocouple outside the furnace
- On-site thermocouple design and modification of thermocouples
- Records and drawing creation on existing furnaces where earlier documentation is incomplete or missing
- Onsite "furnace tubeskin best practices" training for local personnel

Support for existing tubeskin installations:

- Welding supervision
- Routing supervision
- On-site expertises as needed
- Onsite "furnace tubeskin best practices" training for local personnel

Just-In-Case backup support:

- Installation instructions
- Routing advice
- Field transition kits and services
- Onsite "furnace tubeskin best practices" training for local personnel

Ideally, every furnace turnaround that involves a tubeskin thermocouple installation will go exactly as planned. In the real world, this seldom happens.

WIKA Gayesco Services is your best bet for installing a tubeskin thermocouple system in a way that ensures minimal downtime, proper operation, and res





In the refining and petrochemical industries, there are increasing needs for accurate and complete temperature data for the proper operation of critical vessels. These industries continue to see increasing regulatory requirements, emerging competition, and the need to operate older units efficiently.

Having the flexibility to take advantage of new process operating schemes and catalysts becomes important, since there can be significant differences in operating conditions, reactor designs, process parameters, mechanical conditions and stresses, and catalyst reactivity.

Given that, it's critical that the proper design of temperature measurement systems be specified and implemented. By properly selecting or designing a temperature measurement system to fit the exact application needs, you can optimize process profitability, extend catalyst life, enhance operational safety, reduce maintenance costs, increase yields, and improve product quality.

Multipoint Applications

- Hydroprocessing units
 - Column, fractionators, and contactors
 - Continuous catalytic reforming units
 - Fluid catalytic cracking units (dip leg measurement, catalyst cooler measurement, and specialty pipewell and cyclone measurement)
- WIKA/Gayesco has designed multipoint solutions for applications

- Flex-R® flexible multipoint thermometry: Standard flanged assemblies, specialty connections (like Radial Tap and Radial Tap Next Gen), and hybrid solutions
- Linear multipoints: Flexible, drawn, and stuffed multipoints
- Pipewell multipoints: Flex-O™ and Flex-O Purge Tube bimetallic designs, heat transfer block, free-hanging, and spring-loaded

Multipoint Temperature Sensors

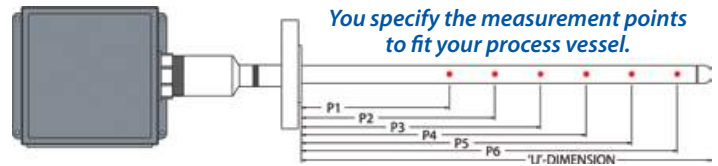

You specify the measurement points to fit your process vessel.

Flex-R Radial Products

- Temperature profiling provides real, useful sensing locations to give you a best understanding of what's happening in the vessel. This profiling can detect hot spots, channeling, and maldistribution
- Fast (4–8 second) response provides insight into process changes
- Engineered solutions — provided by experienced engineers, installers, and industry experts — give you peace of mind that the system follows best practices for radial routing, and maintains the lowest possible footprint to avoid catalyst interruption
- Safety features — secondary containment, safety transitions, and reparability — ensure that when a system is damaged, you won't experience significant downtime or process loss
- Easy retrofit to existing nozzles helps reduce installation costs

Flex-O and Flex-O Purge Tubes

- Flexible design for shipping and installation — for cost effective transportation, easy insertion through bent pipe walls, and no double high cranes required for installation
- Patented purge tube design can purge water and other contaminants from the pipe well
- Features specialized bimetallic strips that bend toward the pipe wall when heated, providing direct contact with the pipe well, resulting in quick response time
- No specialized pipe wells with guide tubes necessary — pipewell can be provided locally
- Engineered spacers reduce friction during installation and removal of the assembly
- Purge tube prevents chloride stress corrosion cracking of the thermocouple sheath inside the pipewell, allows contaminants (like chloride-laden cooling tower vapor) to be flushed from the pipewell
- Purge can be part of a startup procedure, or continuous, in cases where the buildup of hydrogen (through hydrogen migration) causes internal pipewell pressures to be elevated

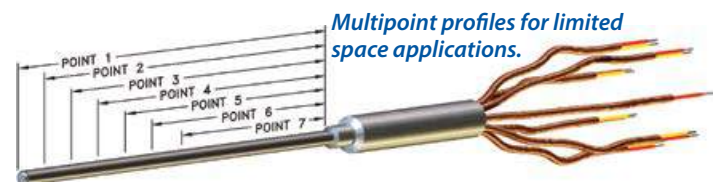

Multipoint profiles for limited space applications.

Mini Multipoints for Tube Sheet Reactors and Pilot Plants

Mini multipoint assemblies are used when a temperature profile is desired, and probe size is a limitation. They are small diameter, individual sensing probes that measure temperature at different positions or elevations. Each individual probe is protected with a stainless steel (or other alloy) sheath. These probes can then be contained in protective tubes.

- Minimize catalyst loading problems
- Minimize maintenance issues by using temperature assemblies that can be removed without disturbing the catalyst or process
- Small sensor avoids influencing process conversion or temperature
- Proper centering in catalyst tube for accurate process temperatures
- Can be calibrated to NIST standards for pilot plant use

Choosing the Right Temperature Transmitter



Model	Description and Programming Options	Inputs	Output	Accuracy	Prices Start at	See Page
STT170 	Programmable with STT17C software. Available with FM, CSA, and ATEX approvals 1500 VAC isolation.	T/C: B, E, J, K, L, N, R, S, T, U, W3, W5; Linear signals: Ω, mV RTD: Pt100, Pt1000, Ni100; (Varies by Model)	4 to 20 mA, HART®, Foundation Fieldbus	T/C: 0.1% span, 0.1Ω or 10μV; RTD: 0.1% span	\$130.00	111
2800T 	DIN-rail or pipe mount, HART® programmable. Built-in digital display. FM, CSA approved. 500 VAC isolation.	T/C: B, E, J, K, N, R, S, T; RTD: Pt100, Pt200, Pt500, Ni, Cu; Linear input: -100 to 100 mV, 0 to 1000Ω	4-20 mA	±0.035% span	\$490.00	116
STT250 	HART® or SCT3000 programmable, optional integral analog or digital indication meter.	T/C: B, E, J, K, N, R, S, T; RTD: Pt100, Pt100J, Pt200; Linear signals: Ω, mV	4-20 mA, HART®, or digital DE	±0.025% span	\$569.00	112
STT 350 	Programmable with Honeywell MC Toolkit. Available with FM and CSA explosion-proof housing	T/C: B, C, D, E, J, K, N, R, S, T, NiNi-Moly, RH Radiamatic; RTD: Pt100, 100J, 200, 500, Cu10 or 25, Ni500; Linear signals: Ω, mV	4-20 mA, digital DE	±0.025% span	\$1065.00	113
SITRANS TH100 	Head-mount transmitter Programmable with SIPROM T Isolated 1kV input against output FM, ATEX approvals available	RTD: Pt100	4-20 mA	0.45° F or 0.1% span	\$113.05	114
SITRANS TH200 	Head-mount transmitter, Programmable with SIPROM T, Isolated 1kV input against output FM, ATEX approvals available	2-, 3-, 4-wire RTDs, Ohms; T/C: B, C, D, E, J, K, L, N, R, S, T, U; Linear signals: mV	4-20 mA	Varies by Input	\$275.07	115
SITRANS TH300 	Head-mount HART® transmitter, Programmable with SIMATIC PDM, Isolated 1kV input against output FM, ATEX approvals available	2-, 3-, 4-wire RTDs, Ohms; T/C: B, C, D, E, J, K, L, N, R, S, T, U; Linear signals: mV	4-20 mA, HART®	Varies by Input	\$397.50	115
SITRANS TH400 	Head-mount transmitter, Profibus PA model programmable with SIMATIC PDM; Foundation Fieldbus model programmable with 375 handheld and AMS; FM, ATEX approvals available	2-, 3-, 4-wire RTDs, Ohms; T/C: B, E, J, K, N, R, S, T, L, U, W3, W5; Linear signals: mV	Profibus PA or Foundation Fieldbus	Varies by Input	\$615.33	114
SITRANS TF 	Field transmitter for harsh environments. Programmable by SIMATIC PDM or SIPROM T, depending on built-in head transmitter. FM-approved units available. IP-68 rating	RTD: 2-, 3-, or 4-wire Pt25 to Pt1000, Ni25 to Ni1000, Cu25 to Cu1000; T/C: B, E, J, K, R, S, T, L, U, N, C, and D; Linear: 1100mV	4-20 mA, HART®	RTD: 0.18° F, T/C: 1.8° to 3.6° F mV: 40 μV	\$885.16	116

Standard transmitter wiring diagrams available on page 495.

Level Measurement Instruments

Flow Measurement Instruments

Pressure Transmitter

Temperature Sensors and Transmitters

Wireless Sensing and Communications

Analytical Instruments and Systems

Programmable Head-Mount Temperature Transmitters



Features

- Analog 4-20 mA output
- STT171: RTD or Ohm input; STT173: RTD, thermocouple, Ohm, or mV input
- Galvanic isolation (STT173)
- DIN Form B head mount
- NAMUR NE43 sensor error response
- Configurable using STT17C configuration tool and PC



Are thermocouple heads and transmitters interchangeable between brands?

Can you mix brands of thermocouple heads and transmitters? It depends on the dimensional standard they meet.

For instance, the DIN (German institute for standardization) Form B standard defines the mounting screw spacing, maximum diameter and height for field-mounted temperature transmitters.

A Form B head-mounted transmitter will fit in any Form B head. So, in theory, all DIN form B heads and transmitters are interchangeable. (Look for a 1.313" or 33.35mm nominal spacing for the mounting screws.)

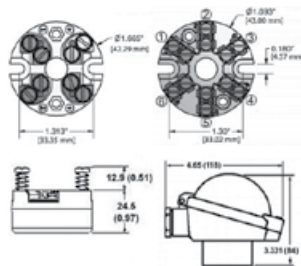

It's important to remember that the size of a head-mounted transmitter is limited. Most transmitters that are not hockey puck styles will not fit in a DIN form B head.

What does NAMUR NE43 do for me?

Why is it a bad idea to set analog signal fault alarms at 2mA or 3mA levels? Because a two-wire transmitter uses the electrical current below 3.6 mA for its own power and operation. So at these low currents, there isn't enough power to generate the fault indication signal and keep the transmitter functioning properly.

NAMUR, an international association of process instrumentation user companies, made a recommendation, known as NE 43, to promote a standardization of the signal level for failure information. You'll see *Compliant to NAMUR NE 43* on the specs of most digital transmitters available today.

The goal of NE43 is to set a basis for using transmitter failure signals in proactive process control strategies. Using these failure signals (A), instrument faults are separated from process measurements (M). And since the faults get signaled at an early stage, the team can design maintenance strategies that keep the instruments in operation and increase productivity.

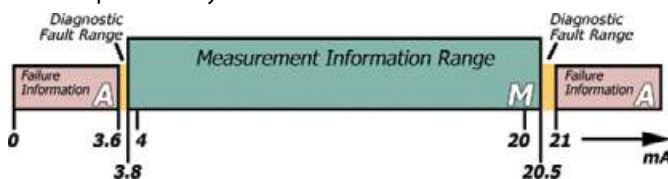

NAMUR NE43 uses the 3.8 to 20.5 mA signal range for measurement information, with ≥ 21 mA or ≤ 3.6 mA to indicate diagnostic failures. With that information, it's easier to detect a fail high condition on a level transmitter, for example, that clearly tells you whether you have a high level or a failed instrument.

NE43 Upscale: 23 mA; NAMUR NE43 Downscale: 3.5 mA

Approvals: FM/CSA/ATEX

Intrinsically Safe/Non-Incendive: Class I Div, 1, Groups A-D, T4; Class 1, Zone 0/1, AEx ia IIC, T4; Class I, Div 2, Groups A-D, T4

Intrinsically Safe/Non-Incendive: Class I, Div 2, Groups A-D, T4; Class I, Zone 0/1, Ex ia IIC, T4; Class 1, Div 2, Groups A-D, T4

Intrinsically Safe Zone 0/1: Ex II 1 GD, EEx ia IIC, T4-T6; Ex II 2 (1) GD, T4-T6, when mounted in a Form B metal head mount enclosure per DIN 43729 that provides a degree of protection of at least IP6X in accordance with EN 60529, that is suitable for the application and correctly installed.

Non-Incendive Zone 2: Class I, Div 2, Groups A-D, T4; Ex II 3 G, EEx nA [L] T4-T6



Ordering Instructions

Make a selection from each table section. Check the availability column to be sure that the unit you need is available. A finished catalog number looks like this: **STT17 _ - _ - _ 0 - _ - _**

Model Selection Guide

Description	Catalog Number	Availability	Price
4-20 mA Output, RTD Input	STT171-	↓	\$130.00
4-20 mA Output, Universal Input	STT173-	↓	249.00
Approvals	FM/CSA/ATEX Intrinsically Safe	BS-0-	• • 0.00
Configuration	Factory Default Configuration	000	• • • 0.00
	Custom Configuration*	T00	• • • 26.00
	Custom Calibration*	C00	• • • 26.00
Configuration Software Tool		STT17C-00-0-000	• • • 515.00
DIN Rail Clip		50017850-001	• • • 15.75

*Includes Printed Configuration or Calibration Report

STT250 Smart Temperature Transmitter

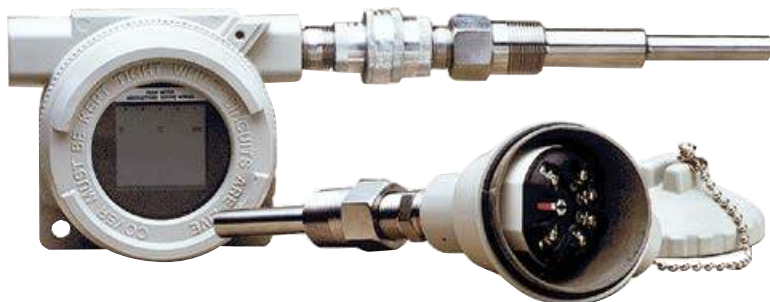

Features

- Reduces maintenance and inventory costs
- Instant alarm generation and post-read validation ensure security
- Failsafe options ensure reliable performance
- Optional integral digital indication meter
- Compact size for direct head mounting
- Available with HART® communications protocol

Input Actuators

Input	Standard	Digital Accuracy Over Range			
		Normal (° F)		Maximum (° F)	
Pt100	IEC751:1986	-328 to 842	0.27	-328 to 1562	0.45
Pt200	(a=0.00385)	-328 to 842	0.54	-328 to 1562	0.72
Pt100J	JISC1604-81 (a=0.00392)	-328 to 842	0.27	-328 to 1184	0.45
Ohms mV		0 to 2000Ω -20 to 120mV	0.40Ω 15mV	0 to 2000Ω -20 to 120mV	0.40Ω 15mV
B	IEC 584 (ITS-90)	1022 to 3308	1.80	392 to 3308	5.40
E		32 to 1832	0.54	-328 to 1832	1.08
J		-1 32 to 1472	0.54	-328 to 2192	1.26
K		-191 to 2498	1.08	-328 to 2498	1.62
N		32 to 2372	0.72	-328 to 2372	2.70
R, S		932 to 3200	1.08	-58 to 3200	1.80
T		-148 to 752	0.54	-418 to 752	0.90

Ordering Instructions

Make one selection from each table section below. A finished catalog number looks like this: STT25M - _ _ _ - 00E - _ _ _ _ - 00

Model Selection Guide

Description		Catalog Number	Availability		Price
STT250: Smart Temperature Transmitter (CE Approved)	No Housing, DIN-Rail or Wall Mounted		↓		\$0.00
	Head Mounted to Sensor in Small Housing			↓	0.00
	Field Mounted in Explosion-Proof Housing (Remotely from or Directly to Sensor)			↓	0.00
4-20 mA Output, SCT Configurable		STT25M-	•	•	569.00
HART 6 Protocol, 4-20 mA Output		STT25S-	•	•	725.00
Digital DE/4-20 mA Output for Digital Integration		STT25D-	•	•	797.00
No Integral Sensor, Probe, or Thermowell Supplied		0-	•	•	0.00
No Housing Supplied		0 _ _ -		•	0.00
Field-Mount Housing Exp-Proof Aluminum/Poly/Epoxy Paint		E _ _ -	a		78.00
Field-Mount Housing, Exp-Proof 316 SS		T _ _ -	a		440.00
Cable Entry	Not Applicable — No Housing Supplied	_ 0 _ -		•	0.00
	1/2" NPT Cable/Conduit Entry	_ N _ -	•	•	0.00
Integral Meter	None	_ _ 0 -	•	•	0.00
	Smart Digital Meter for Field Mount Housing	_ _ S -	i		284.00
Configuration	None — Factory Default Supplied	0 _ _ -	•	•	0.00
	User-Specified Configuration	T _ _ -	•	•	24.00
Customer Tagging	None	_ 0 _ -	•	•	0.00
	316 SS Wired-on I.D. Tag (4 lines, 28 char/line)	_ T _ -	d	d	22.00
Manual	English Operator Manual (one per five units)	_ _ E -	•	•	26.00
Mounting Hardware	None	0 _ _ -	•	•	0.00
	Carbon Steel Mounting Bracket for 2" Pipe	M _ _ -	•		34.00
	Stainless Steel Mounting Bracket for 2" Pipe	S _ _ -	•		86.00
Adapter	No Conduit Adapter for Wiring	_ 0 _ -	•	•	0.00
Lightning Protection	None	_ _ 0 -	•	•	0.00
	Internal Surge/Lightning Protection	_ _ S -	•		129.00
Certificates	No Calibration Certificate	000-	•	•	0.00
SIL2	No SIL2-TUV Certification	00-	•	•	0.00
	SIL2- TUV Certification (STT25S Only)	S2-	•	•	22.00
Approval Body (FM)	Explosion-Proof (Cl. I, Div. 1, Grps A-D) Dust Ignit.-Proof (Cl. II, III, Div. 1 Grps E-G) Intrinsic Safe (Cl. I, II, III, Div. 1 Grps A-G) Non-Incendive (Cl. I, Div. 2, Grps A-D) Suitable for Cl. II, III, Div. 2, Grps F, G	1C	•		21.00
	Explosion-Proof (Cl. I, Div. 1, Grps B-D) Dust Ignit.-Proof (Cl. II, III, Div. 1 Grps E-G) Intrinsic Safe (Cl. I, II, III, Div. 1 Grps A-G) Non-Incendive (Cl. I, Div. 2, Grps A-D) Suitable for Cl. II, III, Div. 2, Grps F, G	1J	•		21.00

Specifications

Accuracy: Output D/A: ±0.025% of span; Cold Junction: ±0.9° F

Digital Ambient Temperature Effect: RTDs or Ohms: 0.050% of reading in Ohms. T/Cs or mV: 0.080% of reading in mV; Output D/A: (0.045% of span; Cold Junction: 40:1 rejection).

Output: 4-20 mA or Honeywell digital DE protocol. HART and DE available with 4 to 20 mA output.

Adjustment Range: No limits within max. range except minimum span limit of 1 engineering unit

Damping Time Constant: Adjustable, 0-102 sec. damping

Output Response Time: 1 sec. to reach 63% of final value with 0 sec. damping

Output Update Time: Approx. 0.5 sec

Sensor Open Circuit: User-selectable open circuit/burnout detection. Upscale or downscale with critical status message. Latching or nonlatching sensor burnout action.

Rejection Mode: Common: 120 dB (1 million to 1) from 50 Hz to 50 kHz. Series: 40 dB (100 to 1) for 50 or 60 Hz ±0.5 Hz (with internal software filter set to local power line frequency).

RFI Rejection: ±0.1% of span at 30V/m over 20 to 1,000 MHz in metallic housing and with shielded cables.

Materials: Terminal Block: Noryl; Module Housing: Noryl with metal interior surface; Connection Screws: Nickel-plated brass

Approvals: Intrinsically Safe to CENELEC, FM, and CSA standards when used with suitable safety barrier. The module is Zone 2 and Explosion-Proof to CENELEC, FM and CSA standards when installed in suitable housing.

In Explosion-Proof Housing: See model selection guide.

Restrictions

- a 20 characters max. on nameplate, available at no cost.
- d Model number does not appear on module or head mount housing. Order wired-on tag.
- i Available only on STT25D and STT25M transmitters.



Level Measurement Instruments

Flow Measurement Instruments

Pressure Transmitter

Temperature Sensors and Transmitters

Wireless Sensing and Communications

Analytical Instruments and Systems

SITRANS T Temperature Transmitters

Siemens' SITRANS TH compact head-mount transmitter is designed to fit in Form B connection heads, even in the flat cover version installed in place of a terminal block. Features include galvanic isolation to 500 VAC, Ex approval, and ruggedness at temperatures ranging from -40° to 185° F.

The basic TH100 is a straightforward compact transmitter for RTD inputs. With measuring technology that's universal and accurate, the PC-programmable TH200 and HART-programmable TH300 offer versatile diagnostics and simulation options in a service-friendly package.

The operating status of these units can be seen at a glance, thanks to a pair of colored LEDs. All your technician needs to do is connect an ammeter to the test sockets, and read the output current — without opening the measuring circuit.

The TH400 is designed for Profibus PA and Foundation Fieldbus installations. TH400 features include programmable sensor, limit values, failure behavior, and galvanic isolation, plus sensor redundancy, when installed with two input sensors.

TH100 and TH200 transmitters can be configured using a special modem and PC-based SIPROM T software. The HART-enabled TH300 offers user-friendly operation using Siemens SIMATIC PDM or a HART communicator. PDM is the configuration tool of choice for TH400 Profibus

At-a-Glance Diagnostics



PA models. The TH400 Foundation Fieldbus model requires use of an FF communicator or AMS software.

SITRANS TW DIN-rail-mount transmitters are great for control room applications. They feature an auxiliary power connection for great flexibility and a relay output. TW transmitters can be configured for 4–20 mA output, 0–20 mA, and 0–10 or 2–10 VDC via HART protocol. The transmitter can be operated via SIMATIC PDM or a HART handheld communicator.

Two-Wire Head-Mount Transmitter for RTDs



Designed for economic use, the TH100 offers low-cost plant operation and reliable measurements. It's the ideal replacement for over-aged analog Pt100 transmitters. Transmitter setup is quick and easy with SIPROM T configuration tool, which can be downloaded free from Siemens website.

- Ideal for Pt100Ω RTD measurements
- 4–20 mA linear temperature output
- Fits a Form B connection head
- Internal temperature compensation
- 8–35 VDC power supply (30V for Ex)
- Configure using modem and free SIPROM T software
- ATEX/cFMus intrinsically safe, non-incendive model available

Model Selection Guide

Description	Catalog Number	Price Each
Siemens SITRANS TH100 Temperature Transmitter for RTD Input		
Non-Explosion-Proof Enclosure	7NG3211-0NN00	\$113.05
Explosion-Proof Enclosure	7NG3211-0BN00	163.14
USB Modem for TH100 and TH200	7NG3092-8KU	349.80

Free SIPROM T software download at Siemens.com.
Order on CD (P/N A5E00354512) for \$7.85

Two-Wire Head-Mount Bus Protocol Transmitters for Universal Inputs



SITRANS TH400 is available either with PROFIBUS PA or FOUNDATION Fieldbus (FF). It is designed to support all common RTD, thermocouple, resistance and millivolt sensors. Setup is quick and easy with SIMATIC PDM (PA) or AMS and handheld communicator (FF). Due to its small size, the device allows flexible mounting options, even in a DIN Type B connection head.

- Fits a Form B connection head
- Pt100Ω RTD, thermocouple, and mV inputs
- Input redundancy with second sensor input
- Single or dual point trim
- High accuracy over ambient temperature range
- Difference and average measurements
- Custom characteristics curve for using with non-standard sensors
- Alarm signal for break on short circuit
- Extensive diagnostics and simulation mode
- Programmable via SIMATIC PDM or HART® handheld communicator
- Rugged design, fully potted electronics
- Galvanic isolation for accuracy and safety in thermocouple applications
- ATEX/cFMus intrinsically safe, non-incendive models available

Model Selection Guide

Description	Catalog Number	Price Each
Siemens SITRANS TH400 Profibus PA Temperature Transmitter		
Non-Explosion-Proof Enclosure	7NG3214-0NN00	\$615.33
ATEX/FM Explosion-Proof Enclosure	7NG3214-0AN00	660.49

Call for price on Foundation Fieldbus models.

Standard transmitter wiring diagrams available on page 495.

SIEMENS

Two-Wire Head-Mount Transmitters for Universal Inputs



SITRANS T TH200



SITRANS T TH300



SITRANS TH200 and TH300 are designed to support all common RTDs, thermocouples, resistance and millivolt-sensors. Unique user-friendly details are implemented: Without opening the 4–20mA loop, the output current can read directly with a multimeter. A red/green LED shows the technician the status at a glance. Additional diagnostic features, like a drag indicator and time meter, plus output current to be used for simulation.

TH200 setup is quick and easy with the transmitter-modem and SIPROM T software. SITRANS TH300 can be configured with SIMATIC PDM or HART handheld programmer. (See pages 94 to 96 for configuration tools.)

- Pt100Ω RTD, thermocouple, and mV inputs
- Fits a Form B connection head
- Temperature compensation via internal reference junction
- Difference and average measurements
- Single or dual point trim
- 4-20 mA linear output signal
- Alarm signal for sensor break or short circuit according to NAMUR 43
- Galvanic isolation for accuracy and safety in thermocouple applications
- Custom characteristic curve for application of non-standard sensors
- ATEX/cFMus intrinsically safe, non-incendive models available
- 8-35 VDC power supply (30V for Ex)
- TH200 programmable using free SIPROM T software, TH300 programmable via HART® and SIMATIC PDM
- Universal input DIN-rail mount models available. Prices start at \$NoMat.ch!

Model Selection Guide

Description	Catalog Number	Price Each
Siemens SITRANS TH200 Universal Input Temperature Transmitter		
Non-Explosion-Proof Enclosure	7NG3211-1NN00	\$275.07
FM-Approved Explosion-Proof Enclosure	7NG3211-1BN00	320.23
Siemens SITRANS TH300 Universal Temperature Transmitter with HART®		
Non-Explosion-Proof Enclosure	7NG3212-0NN00	397.50
FM-Approved Explosion-Proof Enclosure	7NG3212-0BN00	442.66
USB Modem for TH100 and TH200	7NG3092-8KU	349.80
USB HART Modem for TH300	7MF4997-1DB	591.10



Configure just about any HART®-compatible instrumentation with your PC and Siemens' SIMATIC PDM software tool! See pages 95-96 for handheld communicators and PDM software.



SITRANS TW

Four-Wire DIN-Rail Mount Transmitter for Universal Inputs

SITRANS TW is the latest in development of the proven DIN-rail mounted SITRANS T four-wire system. Its diagnostic and simulation functions provide the necessary clarity during commissioning and operation. Its HART®-interface makes the SITRANS TW easily adaptable to any measuring job with SIMATIC PDM.

Physical values can be preset with the simulation function. This enables testing of the complete signal path right as far as the control system without the need for tools. The drag pointer functions measure the system's process variable minimum and maximum. All SITRANS TW control room devices are available in non-intrinsically safe versions, or intrinsically safe versions for applications under extreme conditions.

- Transmitter in four-wire system with HART® communications interface
- Pt100Ω RTD, thermocouple, and linear inputs
- Internal temperature compensation
- 115/230 VAC or 24 VDC power supply
- Configurable via SIMATIC PDM software
- Monitors sensor and cable for open and short circuits; All circuits electrically isolated
- 4-20 mA, 0-20 mA, 0-10V, or 2-10V output
- Can be mounted on 35 mm or 32 mm G DIN rail
- Automatic zero and span correction
- ATEX EEx [ia] or EEx [ib] explosion protection for measurements with sensors in hazardous areas

Prices start at \$496.00. Call for model selection and availability.

Level Measurement Instruments

Flow Measurement Instruments

Pressure Transmitter

Temperature Sensors and Transmitters

Wireless Sensing and Communications

Analytical Instruments and Systems

Programmable Temperature Transmitters

TF Field Mount Transmitter for Harsh Environments

- Pt100Ω RTD, thermocouple, and linear (voltage) inputs
- 4-20 mA output
- Die-cast aluminum or high-grade steel
- IP68 rating, ATEX EEx d approval, FM intrinsically safe and explosion-proof
- Local indicating display; 5 digits, ±99.999
- TF with TK-H head-mount transmitter: 8 to 35 VDC power supply, programmable by SIMATIC PDM or HART® communications device
- Remote sensor mount capability allows the electronics to be isolated from high process temperatures and vibration

SIEMENS



See page 96 for SIMATIC PDM software.

Specifications

Enclosure: NEMA 4X, Die-cast aluminum, polyester-based lacquer, stainless steel rating plate; Electrical/sensor connection: Screw terminals, cable inlet via 1/2-14 NPT threaded gland

FM Approval: Explosion Proof Div 1, Class 1, Groups B-D; Dust-Ignition Proof Div II, III, Class 1, Groups E-G; Non-Incendive Div 1, Class 2, Groups A-D; Intrinsically Safe Div II, III, Class 2, Groups F, G

Input	Measured Range	Minimum Span	Digital Accuracy
Resistance Temperature Detectors			
Pt25Ω to Pt500Ω	-328° to 1562° F (-200° to 850° C)	18° F (10° C)	0.18° F (0.1° C)
Pt500Ω to Pt1000Ω	-328° to 662° F (-200° to 350° C)		
Cu25Ω to Cu1000Ω	-58° to 482° F (-50° to 250° C)		
Thermocouples			
Type B	932° to 3308° F (500° to 1820° C)	90° F (50° C)	3.6° F (2° C)
Type C, Type D	32° to 4172° F (0° to 2300° C)	180° F (100° C)	3.6° F (2° C)
Type E	-418° to 1652° F (-250° to 900° C)	90° F (50° C)	1.8° F (1° C)
Type J	-346° to 2192° F (-210° to 1200° C)	90° F (50° C)	1.8° F (1° C)
Type K	-382° to 2498° F (-230° to 1370° C)	90° F (50° C)	1.8° F (1° C)
Type L	-328° to 1652° F (-200° to 900° C)	90° F (50° C)	1.8° F (1° C)
Type N	-328° to 2372° F (-200° to 1300° C)	90° F (50° C)	1.8° F (1° C)
Type R, Type S	32° to 3182° F (0° to 1750° C)	180° F (100° C)	3.6° F (2° C)
Type T	-364° to 752° F (-220° to 400° C)	72° F (40° C)	1.8° F (1° C)
Type U	-328° to 1112° F (-200° to 600° C)	90° F (50° C)	1.8° F (1° C)
mV Sensor	-10 to 70mV	2mV	40 μV
mV Sensor	-100 to 1100 mV	20 mV	400 μV
Resistance Sensor	0-390Ω	5Ω	0.05Ω
Resistance Sensor	0-2200Ω	25Ω	0.25Ω

Model Selection Guide

Description	Cat. Number	Price
Siemens SITRANS TF Temperature Transmitter: Two-wire system, 4-20 mA output, electrical isolation, 1/2"-14 NPT screwed gland connection, user manual		
SITRANS TF with TH300 (HART®), FM/CSA	7NG3136-5	\$885.16
Housing	Diecast Aluminum Stainless Steel Precision Casting	AC EC
Indicator	None Digital Display	0 1
Mounting Bracket	None Carbon Steel Stainless Steel	0 1 2
SIPROM T Parameterization Software CD	A5E00364512	7.85
USB HART Coupler for SIMATIC PDM/SIPROM	7MF4997-1DB	591.10
RS-232 HART Modem for SIMATIC PDM/SIPROM	7MF4997-1DA	449.65

TouchTemp II Programmable Transmitter

- Two-Button Programming
- 0.05% digital accuracy
- No jumpers, dipswitches or communicators required
- Integral, full five-digit display for process inputs, engineering units, plus warning and programming prompts
- Complete diagnostics: checks for reference voltage, cold junction, EEPROM and CPU errors; indicates under- or over-range and open input conditions



FM and CSA Approved for Hazardous Areas

Specifications

Input Resolution: Temperature: 0.1°; mV: 1 μV; Ohms: 0.01Ω

Temperature Effect: T/C: ±0.2 μV/°C ±0.005% input reading/°C ± CJC; mV: ±0.2 μV/°C ±0.005% input reading/°C; Ohms/RTD: ±0.002Ω/°C ±0.005% input reading/°C; Cold Junction Compensation: 0.005° C/°C

RTD Excitation Current: 200 μA typical

Input Impedance: T/C or mV: >10 megohms

Input/Output Isolation: 500 VAC

Non-Destructive Input: 30 volts peak

Approvals: CSA/FM Non-incendive for Class 1, Div 2, Group A-D hazardous locations



Output: 3.7 to 22 mA DC max., 4 to 20 mA DC calibrated; Resolution: 0.002 mA

D/A Accuracy: ±0.035% span (sum of digital accuracy and D/A accuracy)

RFI Effect: <1% with no abnormal behavior at 10V/m @ 450 MHz

Stability: 0.1% or 0.1° C, for six months with constant reference to conditions

Operating Range: -40°-185° F; 5%-95% RH non-condensing

Transmitter Housing: High impact, conductive plastic; UL94V-O requirements

Input Actuators

Input Type	Conformance	Range Limits		
		°C	°F	
RTD	Pt100 (DIN/IEC751)	0.15° C	-200/850	-328/1562
	Pt200 (DIN/IEC751)	0.3° C	-200/850	-328/1562
	*Pt500 (DIN/IEC751)	0.25° C	-200/260	-328/500
	Pt100 (JIS C 1604)	0.14° C	-200/650	-328/1202
	Ni110 (Bristol 7NA)	0.12° C	-105/310	-157/590
	Ni120 (Minco 7-120)	0.12° C	-80/320	-112/608
	Cu10 (Minco 16-9)	0.5° C	-200/260	-328/500
T/C	J (NIST)	0.25° C	-180/1200	-292/2192
	K (NIST)	0.5° C	-180/1372	-292/2501
	T (NIST)	0.2° C	-200/400	-328/752
	E (NIST)	0.2° C	-200/1000	-328/1832
	R (NIST)	0.6° C	0/1767	32/3212
	S (NIST)	0.5° C	0/1767	32/3212
	*B (NIST)	0.8° C	100/1820	212/3308
N (BS4937)	0.4° C	0/1200	32/2192	
Millivolts			-100 to 100mV	
Ω/RTD 2,3 or 4 wire			0 to 1000 Ω	

*Pt500, B T/C, and DIN T/C Types available on Special Order.

Model Selection Guide

Description	Cat. Number	Price
TouchTemp II™ Temperature Transmitter	2800T	\$490.00
35 mm DIN Rail Mounting Bracket	100665-652	25.00

Level Measurement Instruments

Flow Measurement Instruments

Pressure Transmitter

Temperature Sensors and Transmitters

Wireless Sensing and Communications

Analytical Instruments and Systems

AMETEK LAND Digital Industrial Infrared Thermometers

UNO Stand-Alone Radiation Thermometers

Features

- Fiber-optic thermometers with laser targeting system
- Through-the-lens sighting thermometers
- Peak picker function measures temperature of intermittent targets or where target surface is obscured
- DIN-rail mounted power supply unit and LANDMARK digital panel meter optional

UNO non-contact thermometer systems continuously measure the temperature of hot, moving or inaccessible materials accurately and safely at a distance.

They don't require contact with target object—and they can't interfere with, damage, or contaminate the product or process.



Specifications

Model	U1		U2		U4		U5		V1	
Range (° F)	1100° to 4700°		600° to 2000°		150° to 1000°		750° to 4500°		1100° to 4700°	
Wavelength	1 μm		1.6μm		2.4μm		4.8 to 5.2μm		0.85 to 1.1μm	
Averager	5ms to 5s		5ms to 5s		100ms to 5s		100ms to 5s		15ms to 5s	
Field of View*	100:1	200:1	100:1	30:1	100:1	100:1	50:1	200:1		
Min Target Diameter	3.5mm/ 0.13in	1.8mm/ 0.07in	3.5mm/ 0.13in	11.7mm/ 0.46in	3.5mm/ 0.13in	3.5mm/ 0.13in	7mm/ 0.27in	1.8mm/ 0.07in		
Accuracy	±2° F		±2° F		±2° F		±2° F		±2° F	
Repeatability	±4° F		±4° F		±4° F		±4° F		±4° F	
Absolute	0.75%K	0.75%K	±1%K	±0.9%K	±1%K	0.6%K	0.6%K	0.75%K	1.25%K	
Stability	0.2°/°	0.3°/°	0.2°/°	0.1°/°		< 0.025%T(K)/°C		0.05%/°	0.1%/°	
Ambient	14° – 176° F		14 – 140° F		32 – 122° F		14 – 176° F		14 – 140° F	

- Output:** 4 to 20mA
- Sighting:** 6°, through the lens
- Magnification:** 1.8x
- Peak Picker:** Adjustable 1.5 to 30%/s decay
- Emissivity/NG:** Emissivity adjustable 0.10 to 1.00; Non-greyness adjustable 0.8 to 1.199
- Target Size:** >98% energy
- Eye Relief:** 1.2"/ 30 mm
- Focus Range:** 19.7"/ 0.5 m to infinity variable focus (standard) 13.6"/ 0.35 m to 39.3"/ 1 m (Short variable focus)
- CE:** EN 50-082-2 (immunity), EN 50-081-1 (emission), IEC 1010 (safety)

SPRINT 8 Non-Contact Thermometer



Features

- Compact, rugged industrial thermometer
- Two-wire 4-20 mA linear output
- All-stainless steel tubular threaded body
- USB interface for configuration of measurement span, emissivity, °F/°C reading, and response speed
- Optional green LED aiming diode for improved target alignment, cooling jacket and air purge for use in hostile environments

Specifications

- Measuring Range:** 0° or 32° to 1800°; *Span:* Adjustable, minimum 100° F
- Spectral Range:** 8 to 14 μm
- Optics:** 4", 12", 30" and 48" focal lengths
- Emissivity:** 0.2 to 1.0, adjustable via USB interface
- Response Speed (95% energy):** 50 ms (min.), adjustable 100 ms to 100 s
- Uncertainty:** 1% of measured value specified in Kelvin
- Repeatability:** 0.5% of measured value specified in Kelvin
- Internal Signal Processing:** Digital
- Output:** Two-wire 4–20 mA temperature linear, into 600Ω load at 24V
- Power Supply:** 24 VDC ±25%, ripple 500 mV max; *LED:* 7–30 VDC, <200 mW
- Operating Temperature:** 0° to 160° F
- Housing:** Stainless Steel, IP 65 sealed

See page 488 for emissivities of common materials.

SPOT R100 Digital Infrared Thermometer



Features

- Measures 750° to 3272° F
- Analog and alarm outputs, Ethernet and video in a single device
- Pyrometer readings available through rear display, remotely through web browser, or through SPOT Viewer software

Specifications

- Measurement Ranges:** *Ratio/Detector 1:* 1022°–3272° F; *Detector 2/Duo/ Multi-Mode:* 750°–3272° F
- Repeatability:** <1° C; *Resolution:* <0.1° C
- Response Time:** Adjustable 1ms to 10s
- Field of View:** 230:1 to 90%
- Focus Range:** 300 mm to infinity, locally or remotely
- Detector Type:** *Ratio:* Short wavelength; *Detector 1:* 1.0 μm; *Detector 2:* 1.2 μm
- Uncertainty:** *Detector 1/2 modes:* ±0.25%; *All other modes:* ±0.50%
- Processing Functions:** Averaging, Peak/Valley Picking, Mode Master, Background Compensation
- Interfaces:** *Inputs:* 24 VDC, Ethernet; *Outputs:* 0/4–20mA, 24 VDC, Ethernet
- Sighting:** Integrated local display and remote image capture video, readings and settings. Sighting with pulsed Green LED focus pattern confirmation
- Enclosure:** IP65 / NEMA 4
- Power:** Power over Ethernet or 24 VDC
- Settings:** Local or remote: Emissivity, mode, current output, alarm logic output and thresholds, network settings, focus, LED, language and user name

Level Measurement Instruments

Flow Measurement Instruments

Pressure Transmitter

Temperature Sensors and Transmitters

Wireless Sensing and Communications

Analytical Instruments and Systems

Digital Industrial Infrared Thermometers

Land IQ High Temperature Industrial Spot Thermometers

Features

- Four temperature/wavelength variants
 - Rugged all metal design, for harsh environments
 - Integrated air purge and water-cooling protects in all conditions
 - Plug-and-play four wire operation — Zero configuration
 - Advanced signal processing simplifies control applications
 - Peer-to-peer and multidrop RS485 digital interface
 - Two relay outputs — Alarm Process temperature and sensor over temperature
 - Compact size — terminal connection uses existing wiring.
- Thermometers feature integrated water cooling, air purge and screw terminal connections to facilitate cost effective operations. Configure using any permutation of four wavelengths/feature levels/focus distances.



Specifications

	Basic	Standard	Enhanced	Premium
Integrated Air Purge/Water Cooling	✓	✓	✓	✓
Simple Screw Terminal Connection	✓	✓	✓	✓
Emissivity 4-20mA output	✓	✓	✓	✓
Adjustable Emissivity (0.1 To 1.0)	✓	✓	✓	✓
Factory Selectable Focus	✓	✓	✓	✓
Laser Alignment		✓	✓	✓
Peer-To-Peer and Multidrop RS485			✓	✓
Advanced Signal Processing			✓	✓
2 x Alarm Relays			✓	✓
User Selectable Focus				✓
Model	IQ1	IQ2	IQ5	IQR
Temperature	1022°–3182° F	482°–2372° F	392°–2012° F	1292°–3182° F
Spectral Response	1µm	1.6µm	5µm	1µm Ratio
Field of View (90%)	110:1	110:1	60:1	110:1
Response Time	10ms	10ms	50ms	10ms
Accuracy	0.3%+1° C	2° C	0.35%+1° C	0.6%+1.5° C
Ambient Limit	32°–158° F (Operating)			
EMC	EN 61326			
Enclosure Rating	IP65 / NEMA 4X			
Power Supply	18 to 30 VDC			

SOLOnet Web-Ready Infrared Thermometer



Features

- Intelligent, digital infrared thermometers with flexible configuration methods
- Field-adjustable focal length — four distances in one unit. Pick one when you order, and change in the field by swapping focus rings to suit your changing needs.
- Laser targeting for accurate spot measurements
- Survives harsh environments and ambient temperatures up to 158° F with no added cooling requirement
- Protection assemblies available for air and water cooling in extreme radiant heat or ambient temperatures to 250° F
- Sapphire protection window standard on all units
- RS485, Web or Ethernet interface;
- No signal processor unit or special software needed
- Rugged aluminum housing, IP65, NEMA 4X
- Calibrated to ISO 19075

Four different SOLOnet thermometer models give you the choice of operating wavelength, variants, laser alignment, and measurement ranges from 382° to 3182° F. The measurement span can be selected anywhere within the thermometer range, with a minimum span of 90° F.

SOLOnet can be used in stand-alone, single point, or multipoint installations with individual remotely-adjustable sub-temperature ranges, current outputs, emissivity, or non-greyness compensation and user-defined alarm settings. Choice of built-in peak picker, track and hold, or averager signal processing functions ensures accurate measurement.

Temperatures are displayed on a PC or computer system via the web browser. Parameters adjusted using drop-down menus or text windows. Infrared thermometer system offer maximum flexibility and connectivity.

Specifications

Model	SN11	SN21	SN51	SNR1
Range (° F)	1022° to 3182°	482° to 2372°	392° to 2012°	1292° to 3182°
Wavelength	1 µm	1.6µm	5µm	1µm ratio
Field of View	100:1	100:1	50:1	100:1
Response	10ms	10ms	50ms	10ms
Stability	0.2°/°	0.2°/°	0.2%K/K	0.05K/K
Accuracy	0.3%K	2K	0.35%K	0.6%K
Focus:	Fixed, user configurable; 9.8", 19.7", 39.4" and infinity			
Output:	0 to 20 mA or 4 to 20 mA, user selectable, isolated 50V			
Ambient Limits:	32° to 158° operating, water-cooled units can operate at temps to 250° F with insulated cables. Non-insulated cables good to 176° F			
Power Supply:	18 to 30 VDC (24 VDC nominal)			
Laser Sighting:	Laser defining optical axis, Class 2, 1mW, 650 nm, 120s ON duration, automatic switch-off			
Alarms:	High, low, internal temperature, emissivity/NG signal lost			

AMETEK LAND Infrared Process Imaging and Scanning

LSP-HD Infrared Linescanners

Features

- High resolution, focusable optical system allows detection of small temperature differences, providing optimum quality through improved process control
- Designed for operation in harsh industrial environments – sealed to IP65 (NEMA4)
- Plug-and-play installation via a single Ethernet cable connection, reducing installation time, costs and complexity
- Range of data output formats for easy connection to the process control system



LSPHD Functions

- High definition thermal imaging from a combination of fast scan speeds (up to 150Hz) and high resolution optics (1000 samples per scan line)
- Streamed process data is available directly from the scanner via digital communications for direct integration into plant control systems
- Analog and digital outputs can be connected via the ethernet link or connected with external process sensors

Control and Analysis Software

The LAND Data Server provides detailed temperature measurement information, analysis tools and product storage for product quality control purposes and subsequent analysis.

LSPHD Application

Industry	Typical Temperature Measurement Range	Recommended Scanner
Cement	68° to 482° F	LSPHD 60
	122° to 752° F	LSPHD 61
	212° to 1112° F	LSPHD 62
Conveyors	68° to 482° F	LSPHD 60
	122° to 752° F	LSPHD 61
	212° to 1112° F	LSPHD 62
Glass	302° to 1382° F	LSPHD 5FL & LSPHD 50
	932° to 2012° F	LSPHD 52
Iron & Steel	1112° to 2552° F	LSPHD 10
	1292° to 2732° F	LSPHD 11
	392° to 1562° F	LSPHD 20
	572° to 1832° F	LSPHD 21
Non-wovens	68° to 482° F	LSPHD 60
	122° to 752° F	LSPHD 61
	212° to 1112° F	LSPHD 62
Plastics	122° to 662° F	LSPHD 71
	68° to 482° F	LSPHD 60
Other Industries	122° to 752° F	LSPHD 61
	212° to 1112° F	LSPHD 62
Other Industries	68° to 1112° F	LSPHD 60, 61 & 62

NIR Fixed Thermal Imaging Camera

Features

- High resolution radiometric thermal imager giving detailed temperature data transmitted via a high speed digital connection
- Robust housing for harsh industrial environments
- Choice of four models ranging from 1100° to 5400° F, plus four field of view options
- High temperature measurement accuracy
- Simple installation and ease of use — minimizes cost and complexity
- 2 Year Warranty — guarantee of reliability
- Export Licence Free — rapid, hassle-free shipping
- Range of 5 Close-up lenses (focal range from 4" / 100 mm upwards) available — match your product exactly to your application



NOTE: Can directly replace an existing short wavelength, high temperature spot thermometer (like a System 4 M1 thermometer)

Specifications - Configurations

	8 mm*	25 mm	50 mm	75 mm
1112° to 1832° F	10-08	10-25	10-50	10-75
1472° to 2552° F	14-08	14-25	14-50	14-75
1832° to 3272° F	18-08	18-25	18-50	18-75
2552° to 5432° F	-	30-25	30-50	30-75
Lens Type	8 mm	25 mm	50 mm	75 mm
Field of View (h x v)	44° x 33°	14.4° x 10.8°	7.2° x 5.4°	4.8° x 3.6°
Focus Range	600 mm (2') to infinity (manual focus)			
IFOV	1.2 mrad	0.40 mrad	0.20 mrad	0.13 mrad
Window material	Glass			
Lens Ref.	G1	G2	G3	G4
Focal Range mm/inch	100 to 123/ 4 to 4.85	120 to 160/ 4.7 to 6.3	150 to 215/ 5.9 to 8.5	200 to 340/ 7.8 to 13.4
System Temperature Measuring Accuracy	0.5% (K) up to 2912° F and 1% (K) above			
Spectral Range	0.78 to 1.1 µm			
Detector	Silicon focal plane array			
Detector array format	656 x 494			
Frame Frequency	30 Hz (Gigabit Ethernet)			

Infrared Process Imaging and Scanning

Arc Radiometric Thermal Imaging Camera

Features

- High resolution thermal imager
- Remote, motorized focus
- Four lens options: View any target, at any distance with outstanding clarity
- Wide ambient temperature operating range (32° to 1832° F)
- User-friendly monitoring software enables visualization of thermal data
- IP65/NEMA 4X rated enclosure, choice of ATEX and Class/Division approvals for hazardous area applications
- Direct connection to I/O modules through industrial ethernet

Arc thermal imager features a rugged IP65/NEMA 4X sealed all metal design. Options include a choice of two temperature ranges, four lenses, two frame rates and three software variants to meet your specific application requirements.

I/O

- A range of DIN rail mounted modules providing analog/digital inputs and outputs
- Direct connection to Arc Camera over Ethernet
- Analogue output of areas of interest
- Digital outputs for high/low or warning alarm levels

Smart Features

- Four areas with min, max, mean and noise filter
- Individual emissivities
- Four Alarms (high/low) per area
- Configured with **Viewer+** Software

Software Options

ArcViewer (Free with unit): Image view and basic temperature data

ArcViewer+: Adds ability to configure Smart features for stand-alone operation

Land Image Processing Software (LIPS): Image recording, profiles, areas of interest, alarms, saving and image storage



NIR-b Boroscope Imaging Camera

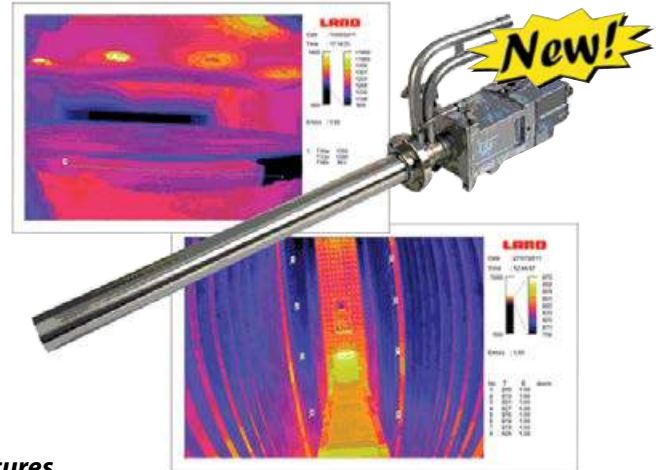

Features

- 24-hour, seven-day monitoring — no blind time
- 44° or 90° angle for full furnace or tank internal thermal view
- Uses high definition temperature maps for optimum process control and high accuracy
- Thermocouple at NIR-b tip provides high limit alarm
- Low sensitivity to emissivity changes; can be used through glass or quartz view ports
- Integrated air purge maintains a dust-free optical system while consuming minimal instrument air
- High performance water cooling for low running costs
- Dedicated software for data points, areas of interest, automated alarms and long term data trending

Thermal imaging normally requires large openings in the refractory to enable viewing critical areas, causing significant wasted energy from heat loss and difficulty keeping the opening free from debris. The NIR Boroscope (NIR-b) thermal imager accurately profiles the temperature of the entire furnace with only a small opening in the wall.

Specifications

Detector Type: Uncoated silicon focal plane array

Measurement Range: 1112° to 3272° F

Spectral Response: 0.85 to 1.05 μm

Field of View (Horizontal): 44° or 90°; *Instantaneous Field of View:* 1.2 mrad (44°)/2.4 mrad (90°)

Focus Range: 0.5 meters to infinity

Probe: Length: 12", 24" or 36"; Diameter: 2.2"

Flange: 3" ANSI or PN16

Sealing: IP 65 / NEMA 4

Vibration: 0.5 mm, 10 to 60 Hz; 3g, 60 to 300 Hz

Image Pixels: 656 x 494 for 324,000 data points

Interfaces: Separate sockets / lead for power and data connection

Power Rating: 24 VDC, 3 watts

Data Output: Digital data over 30 Hz Gigabit Ethernet (RJ-45)

Software: Complete Land Image Processing Software (LIPS) package for PC

Accessories: Power supply, cables, software, termination box

CE Certification: EN 61326: 1999 B

Specifications

Model Range	ARC-8-FOV-500-Rate	ARC-8-FOV-1000-Rate
Temperature Range	32 to 932° F	212 to 1832° F

Spectral Response: 8 to 14 μm

Image Resolution: 384 x 288

Horizontal Field of View: 11°, 22°, 44° or 60°

Focus Range: 0.3m>infinity (22°, 44°, 60°) / 0.5m>infinity (11°)

Accuracy: $\pm 2\%$ or $\pm 2^\circ\text{C}$

Frame Rate: LF: 7.5 Hz; HF: 30 Hz



AMETEK LAND**FTI-E Fixed Thermal Imaging Systems**

Provide your plant operators real-time information for quality control and process data

- Record ideal thermal profile and continuously monitor to check deviations in the process for comparative analysis
- Trigger alarm conditions with thermal data for process and quality control
- Measure minimum, maximum, and average temperatures
- Record and playback thermal images of moving processes to pinpoint potential problems

Features

- High resolution radiometric thermal image, transmits over high speed digital connections
- Optional touchscreen allows display and control
- Integrated manual pan-and-tilt mount makes it easy to align the unit after installation
- Air purge keeps lenses clean
- Flexible interface connects TCP/IP, OPC, analog signals, or alarm outputs
- Full range of analysis and process control functions: point or area temperature measurement, temperature profiles, histograms, isotherms, measurement trending, and digital zoom
- Thermal analysis software lets you monitor or control up to four imagers at full frame rate

Ametek Land's FTI-E process imaging system gives a complete thermal view of the process, with displays that respond to changes. These changes can trigger alarms, automate other processes, and provide quality control data directly to the control room.

The FTI can be used in all types of applications, in the harshest plant conditions, continuously providing fast response data. It can replace portable solutions that provide only a periodic check, to monitor availability and free up personnel to act on the data rather than capture it.

Landscan Windows Control and Analyze (WCA) Software

The LANDSCAN WCA software builds upon the proven capabilities of the fully featured LANDSCAN for Windows NT product.

Features

- Multi-scanner operation.
- Flexible display capabilities, being a genuine MDI Windows application
- Simultaneous display and processing of multiple live data streams with historical data streams
- Scalable input/output capabilities to suit requirements
- Post processing capabilities including an auto size product to window and multi-window linked cursors function
- Automatic post product comparison

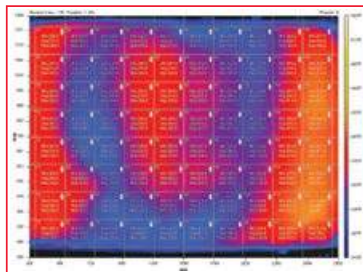
**Specifications**

Imager Model	FTI-E 800	FTI-E 801	FTI-E 490	FTI-E 391
Measuring Range	-4° to 250° F	120° to 660° F	300° to 1100° F	1100° to 2910° F
Ambient Range	50° to 110° F	40° to 120° F		
Spectral Response	Nominal 8–14 μm		Nominal 5 μm	Nominal 3.9 μm
Thermal Resolution	<0.15° F	<0.3° F	<0.36° F	<0.54° F
Measuring Accuracy	±3° F	±1% (±3° below 300° F)	±1%	±1%

FTI-E Thermal Imagers: Four imagers are available, with different temperature ranges and 32° or 16° field-of-view, 4 x 3 format.

FTI-E Control Processors: Industrial processors provide local process control, configuration, and process visualizations.

Industrial Housing: Designed to protect the imager in even the harshest operating environments for reliable, continuous operation.

LIPS FTI Software: Real-time thermal analysis software uses the latest advances in image processing and digital communications to provide solutions for a wide range of processes. It is capable of monitoring or controlling up to four imagers at full frame rate, and transfer data via TCP/IP, optional OPC server, analog signal, or alarm output. The software automatically stores images and video in the event of an alarm.

- Tagging and linking of multiple live data streams to create a Production Process oriented product database
- High reliability analog output availability for process control applications direct from LANDSCAN Control processors
- Combined Data Source facility to extend product coverage using multiple LANDSCAN Heads
- Optional interfacing with external process sensors including process speed sensors, weld detectors, HMDs etc. via LANDSCAN Control Processor
- Network links to external plant/process computers allow rapid transfer of packaged and highly processed data sets
- Optional support of multiple LANDSCAN WCA Client workstations — accessing both live and historical data through the LANDSCAN WCA Data Server workstation
- Offline Client software available to provide access to historical data for quality control purposes

Temperature Sensor and Transmitter Accessories



Mini Power DIN Rail Mount DC Power Supply



Specifications

Input voltage: 85–264 VAC, 90 VDC–350 VDC
Output voltage: 24 V; Range: 22.5–28.5 VDC (>24 V constant)
Nominal voltage: Input: 100–240 VAC; Output: 24 V ± 1 %
Current: Continuous: Max. 20 mA; Output: 1 A (Up to 60° C); 1.3 A (With POWER BOOST); Inrush surge: <15 A (Typical)
Input Fuse: 1.25 A (Slow-blow, internal)
MTBF: >500,000 hr in accordance with IEC 1709 (SN 29 500)
Status display: LED green
Enclosure: IP20, Class 2 (in an enclosed control cabinet) Installation: Horizontal DIN rail

Ambient temperature: -25°–70° C (> 60° C derating)
Approval: UL; EN 60950/VDE 0805 (SELV); DIN VDE 0100-410, DIN VDE 0106-1010; CE compliance with EMC directive 89/336/EEC; Emitted interference: EN 50081-2; Immunity: EN 61000-6-2

Model Selection Guide

Description	Catalog Number	Price
DIN-Rail 24 VDC Power Supply, 1A	2938840	\$125.00
DIN-Rail 24 VDC Power Supply, 1.3A	2866446	115.00
DIN-Rail 24 VDC Power Supply, 2A	2938730	150.00

Switching DC Power Supply

- No jumpers or dip switches
- DIN rail or panel mount
- LED operation indicator
- Universal AC input (85–264 VAC)
- DC compatible input (105–370 VDC)
- UL508 listing; CE marking according to both LVD and EMC
- Spring-up, finger-safe terminals for ring lug terminated wire
- Auto resetting output over current protection



Specifications

Output Capacity: 23 VDC at 300 mA; Leakage Current: 0.75mA max.
Input Voltage: 100–240 VAC (85–264 VAC), 50/60Hz (47–63Hz); Overvoltage Protection: Output turns off at 105% (typical)
Internal Fuse Rating: 2A
Overload Protection: 120% typical (Zener-limiting)
Operating Conditions: 14° to 140° F (-10° to 60° C); 20 to 90% rH

Model Selection Guide

Description	Catalog Number	Price
24 VDC Power Supply, 7.5W, 300mA Output	PS5R-A24	\$60.00
12" Length DIN Rail	BNDN-12	3.95
DIN Rail Clip	BNL5	2.00

More power supplies on 362 and 363.

Build Your Own Temperature Assemblies with the UE Sensor Box



Ordering Instructions

The basic Sensor Box™ includes toolbox, tools, parts, and any combination of up to six sensors. * Specify calibration J, K, T, or E (e.g., MI1113KU). Fiberglass lead pods are rated to 900° F; Teflon leads are rated to 400° F.

Model Selection Guide

Description	Catalog Number	Price Each
Basic UE Sensor Box™, complete with toolbox, tools, and parts listed below.	SB250	\$650.00
Sensor Parts in Toolbox	Housing, 0.250" OD x 24" long, 316 stainless steel NEMA 4 Aluminum terminal head, 4-post ceramic block Spring-loading kit for AC1054 head Nipple, 1/2" NPT x 2" long, carbon steel Union, 1/2" NPT, carbon steel for NEMA 4 applications Wire guide (Bag of 10) Crimper, tube cutter, screwdriver, tape measure, wire stripper	(6) HS2524 (3) AC1054 (6) AC1087 (6) NC1002 (3) UC1011 (1) TS1092 (1 ea.) Tools
Sensors* Replace with T/C Type (Mix and match as needed.)	Pt100Ω RTD, 3-wire, Teflon insulation, max. temp. 400° F Pt100Ω RTD, 3-wire, fiberglass insulation, max. temp. 900° F Thermocouple with ungrounded junction, fiberglass leads Thermocouple with grounded junction, fiberglass leads Thermocouple with ungrounded junction, Teflon leads Thermocouple with grounded junction, Teflon leads	RT1260 RT1254 MI1113_U* MI1113_G* MI1113TF_U* MI1113TF_G*
Optional Components	316 stainless steel housing, 0.250" OD x 12" long 2" long carbon steel nipple, 1/2" NPT 2" long stainless steel nipple, 1/2" NPT 1/2" NPT union, carbon steel, for NEMA 4 1/2" NPT union, stainless steel, for NEMA 4 Plastic wire bushing (pack of 10)	HS2512 NC1002 NS1002 UC1011 HF1091 TS1092
		8.00 3.00 8.00 17.00 38.00 2.00

Have your plant back up in minutes, not days! United Electric's Sensor Box is designed for maintenance and instrument technicians, in any plant where temperature sensors are an important part of the operation — and down-time is not an option.